



**THE DATASHEET OF
ADG701LBRJZ-REEL7**



FEATURES

- 1.8 V to 5.5 V single supply
- 2 Ω (typical) on resistance
- Low on resistance flatness
- Guaranteed leakage specifications up to 85°C
- −3 dB bandwidth > 200 MHz
- Rail-to-rail operation
- Fast switching times
 - t_{ON} 18 ns
 - t_{OFF} 12 ns
- Typical power consumption < 0.01 μW
- Transistor/Transistor Logic (TTL)/CMOS-compatible

APPLICATIONS

- Battery-powered systems
- Communication systems
- Sample-and-hold systems
- Audio signal routing
- Video switching
- Mechanical reed relay replacement

GENERAL DESCRIPTION

The ADG701L/ADG702L are monolithic CMOS SPST switches. These switches are designed using an advanced submicron process that provides low power dissipation yet also offers high switching speed, low on resistance, and low leakage currents. In addition, −3 dB bandwidths greater than 200 MHz can be achieved.

The ADG701L/ADG702L can operate from a single 1.8 V to 5.5 V supply, making it ideal for use in battery-powered instruments and with the new generation of DACs and ADCs from Analog Devices, Inc.

Figure 1 and Figure 2 show that with a logic input of 1, the switch of the ADG701L is closed while the switch of the ADG702L is open. Each switch conducts equally well in both directions when on.

The ADG701L/ADG702L are packaged as 5-lead SOT-23, 6-lead SOT-23, and 8-lead MSOP.

FUNCTIONAL BLOCK DIAGRAMS

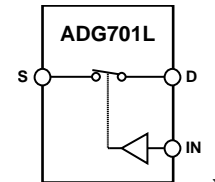

SWITCHES SHOWN FOR A LOGIC 1 INPUT

Figure 1.

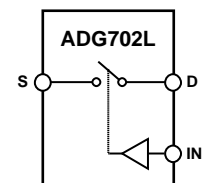

SWITCHES SHOWN FOR A LOGIC 1 INPUT

Figure 2.

PRODUCT HIGHLIGHTS

1. 1.8 V to 5.5 V Single-Supply Operation. The ADG701L/ADG702L offer high performance, including low on resistance and fast switching times. The ADG701L/ADG702L are fully specified and guaranteed with 3 V and 5 V supply rails.
2. Very Low R_{ON} (3 Ω Maximum at 5 V, 5 Ω Maximum at 3 V). At 1.8 V operation, on resistance (R_{ON}) is typically 40 Ω over the temperature range.
3. On Resistance Flatness, R_{FLAT(ON)} (1 Ω Maximum).
4. −3 dB Bandwidth > 200 MHz.
5. Low Power Dissipation. CMOS construction ensures low power dissipation.
6. Fast t_{ON}/t_{OFF}.

TABLE OF CONTENTS

Features	1	Typical Performance Characteristics	7
Applications	1	Test Circuits	8
General Description	1	Terminology.....	9
Functional Block Diagrams.....	1	Applications Information	10
Product Highlights	1	Supply Voltages	10
Revision History	2	Bandwidth	10
Specifications	3	Off Isolation	10
Absolute Maximum Ratings	5	Outline Dimensions.....	11
ESD Caution.....	5	Ordering Guide	12
Pin Configurations and Function Descriptions.....	6		

REVISION HISTORY

1/2020—Rev. 0 to Rev. A

Changes to Table 1	3
Reformatted Test Circuits Section	8
Changes to Bandwidth Section.....	10
Updated Outline Dimensions.....	11
Changes to Ordering Guide.....	12

11/2006—Revision 0: Initial Version

SPECIFICATIONS

$V_{DD} = 5\text{ V} \pm 10\%$ and $GND = 0\text{ V}$. Temperature range for the B version is -40°C to $+85^{\circ}\text{C}$, unless otherwise noted.

Table 1.

Parameter	B Version		Unit	Test Conditions/Comments
	+25°C	-40°C to +85°C		
ANALOG SWITCH				
Analog Signal Range		0 V to V_{DD}	V	
R_{ON}	2		Ω typ	Source Voltage (V_S) = 0 V to V_{DD} and source off leakage = -10 mA , see Figure 12
$R_{FLAT(ON)}$	3	4	Ω max	$V_S = 0\text{ V}$ to V_{DD} and source current (I_S) = -10 mA
	0.5	1.0	Ω typ Ω max	
LEAKAGE CURRENTS				
Source Off Leakage, I_S (Off)	± 0.01		nA typ	$V_{DD} = 5.5\text{ V}$ $V_S = 4.5\text{ V}/1\text{ V}$ and drain voltage (V_D) = $1\text{ V}/4.5\text{ V}$, see Figure 14
Drain Off Leakage, I_D (Off)	± 0.25	± 0.35	nA max	$V_S = 4.5\text{ V}/1\text{ V}$ and $V_D = 1\text{ V}/4.5\text{ V}$, see Figure 14
	± 0.01		nA typ	
Channel On Leakage, I_D, I_S (On)	± 0.25	± 0.35	nA max	$V_S = V_D = 1\text{ V}$ or 4.5 V , see Figure 18
	± 0.01		nA typ	
	± 0.25	± 0.35	nA max	
DIGITAL INPUTS				
Input High Voltage, V_{INH}		2.4	V min	
Input Low Voltage, V_{INL}		0.8	V max	
Input Current I_{INL} or I_{INH}	0.005		μA typ	Digital input voltage (V_{IN}) = V_{INL} or V_{INH}
		± 0.1	μA max	
DYNAMIC CHARACTERISTICS¹				
t_{ON}	12		ns typ	Load resistance (R_L) = $300\ \Omega$ and load capacitance (C_{LOAD}) = 35 pF
t_{OFF}		18	ns max	$V_S = 3\text{ V}$, see Figure 16
	8		ns typ	$R_L = 300\ \Omega$ and $C_L = 35\text{ pF}$
Charge Injection		12	ns max	$V_S = 3\text{ V}$, see Figure 16
	5		pC typ	$V_S = 2\text{ V}$ and source resistance (R_S) = $0\ \Omega$, $C_L = 1\text{ nF}$, see Figure 17
Off Isolation	-55		dB typ	$R_L = 50\ \Omega$, $C_L = 5\text{ pF}$, and $f = 10\text{ MHz}$
	-75		dB typ	$R_L = 50\ \Omega$, $C_L = 5\text{ pF}$, and $f = 1\text{ MHz}$, see Figure 13
Bandwidth -3 dB	200		MHz typ	$R_L = 50\ \Omega$ and $C_L = 5\text{ pF}$, see Figure 15
Source Capacitance (C_S) (Off)	17		pF typ	
Drain Capacitance (C_D) (Off)	17		pF typ	
C_D, C_S (On)	38		pF typ	
POWER REQUIREMENTS				
Supply Current (I_{DD})	0.001		μA typ	$V_{DD} = 5.5\text{ V}$ Digital inputs = 0 V or 5 V
		1.0	μA max	

¹ Guaranteed by design, not subject to production test.

$V_{DD} = 3\text{ V} \pm 10\%$ and the GND pin = 0 V. Temperature range for the B version is -40°C to $+85^{\circ}\text{C}$, unless otherwise noted.

Table 2.

Parameter	B Version		Unit	Test Conditions/Comments
	+25°C	-40°C to +85°C		
ANALOG SWITCH				
Analog Signal Range		0 V to V_{DD}	V	
R_{ON}	3.5		Ω typ	$V_S = 0\text{ V}$ to V_{DD} and $I_S = -10\text{ mA}$, see Figure 12
	5	6	Ω max	
$R_{FLAT(ON)}$	1.5		Ω typ	$V_S = 0\text{ V}$ to V_{DD} and $I_S = -10\text{ mA}$
LEAKAGE CURRENTS				
Source Off Leakage I_S (Off)	± 0.01		nA typ	$V_{DD} = 3.3\text{ V}$ $V_S = 3\text{ V}/1\text{ V}$ and $V_D = 1\text{ V}/3\text{ V}$, see Figure 14
	± 0.25	± 0.35	nA max	
Drain Off Leakage I_D (Off)	± 0.01		nA typ	$V_S = 3\text{ V}/1\text{ V}$ and $V_D = 1\text{ V}/3\text{ V}$, see Figure 14
	± 0.25	± 0.35	nA max	
Channel On Leakage I_D, I_S (On)	± 0.01		nA typ	$V_S = V_D = 1\text{ V}$ or 3 V , see Figure 18
	± 0.25	± 0.35	nA max	
DIGITAL INPUTS				
Input High Voltage, V_{INH}		2.0	V min	$V_{IN} = V_{INL}$ or V_{INH}
Input Low Voltage, V_{INL}		0.4	V max	
Input Current				
I_{INL} or I_{INH}	0.005		μA typ	
		± 0.1	μA max	
DYNAMIC CHARACTERISTICS¹				
t_{ON}	14		ns typ	$R_L = 300\ \Omega$ and $C_L = 35\text{ pF}$ $V_S = 2\text{ V}$, see Figure 16
		20	ns max	
t_{OFF}	8		ns typ	$R_L = 300\ \Omega$ and $C_L = 35\text{ pF}$ $V_S = 2\text{ V}$, see Figure 16
		13	ns max	
Charge Injection	4		pC typ	$V_S = 1.5\text{ V}$, $R_S = 0\ \Omega$ and $C_L = 1\text{ nF}$, see Figure 17
Off Isolation	-55		dB typ	
	-75		dB typ	$R_L = 50\ \Omega$, $C_L = 5\text{ pF}$, and $f = 10\text{ MHz}$ $R_L = 50\ \Omega$, $C_L = 5\text{ pF}$, and $f = 1\text{ MHz}$, see Figure 13
Bandwidth -3 dB	200		MHz typ	
C_S (Off)	17		pF typ	$R_L = 50\ \Omega$ and $C_L = 5\text{ pF}$, see Figure 15
C_D (Off)	17		pF typ	
C_D, C_S (On)	38		pF typ	
POWER REQUIREMENTS				
I_{DD}	0.001		μA typ	$V_{DD} = 3.3\text{ V}$ Digital inputs = 0 V or 3 V
		1.0	μA max	

¹ Guaranteed by design, not subject to production test.

ABSOLUTE MAXIMUM RATINGS

$T_A = 25^\circ\text{C}$, unless otherwise noted.

Table 3.

Parameter	Rating
V_{DD} to GND Pin	-0.3 V to +7 V
Analog, Digital Inputs ¹	-0.3 V to $V_{DD} + 0.3$ V or 30 mA, whichever occurs first
Continuous Current, S or D	30 mA
Peak Current, S or D	100 mA, pulsed at 1 ms, 10% duty cycle maximum
Operating Temperature Range	
Industrial (B Version)	-40°C to +85°C
Storage Temperature Range	-65°C to +150°C
Junction Temperature	150°C
MSOP Package, Power Dissipation	315 mW
θ_{JA} Thermal Impedance	206°C/W
θ_{JC} Thermal Impedance	44°C/W
SOT-23 Package, Power Dissipation	282 mW
θ_{JA} Thermal Impedance	229.6°C/W
θ_{JC} Thermal Impedance	91.99°C/W
Lead Temperature, Soldering	
Vapor Phase (60 sec)	215°C
Infrared (15 sec)	220°C
Lead-free Reflow Soldering	
Peak Temperature	260 (+0/-5)°C
Time at Peak Temperature	10 sec to 40 sec
ESD	2 kV

¹ Overvoltages at IN, S, or D are clamped by internal diodes. Current should be limited to the maximum ratings given.

Stresses at or above those listed under Absolute Maximum Ratings may cause permanent damage to the product. This is a stress rating only; functional operation of the product at these or any other conditions above those indicated in the operational section of this specification is not implied. Operation beyond the maximum operating conditions for extended periods may affect product reliability.

ESD CAUTION



ESD (electrostatic discharge) sensitive device. Charged devices and circuit boards can discharge without detection. Although this product features patented or proprietary protection circuitry, damage may occur on devices subjected to high energy ESD. Therefore, proper ESD precautions should be taken to avoid performance degradation or loss of functionality.

PIN CONFIGURATIONS AND FUNCTION DESCRIPTIONS

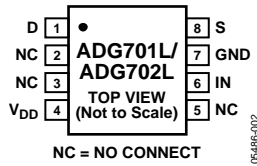

Figure 3. 8-Lead MSOP Pin Configuration

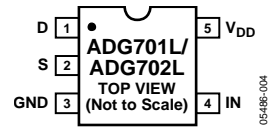

Figure 5. 5-Lead SOT-23 Pin Configuration

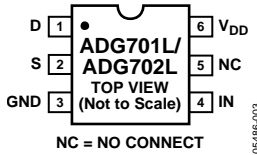

Figure 4. 6-Lead SOT-23 Pin Configuration

Table 4. Pin Function Descriptions

Pin Number			Mnemonic	Description
8-Lead MSOP	6-lead SOT-23	5-lead SOT-23		
1	1	1	D	Drain Terminal. Can be an input or output.
2, 3, 5	5	Not applicable	NC	No Connect.
4	6	5	V _{DD}	Most Positive Power Supply Potential.
6	4	4	IN	Logic Control Input.
7	3	3	GND	Ground (0 V) Reference.
8	2	2	S	Source Terminal. May be an input or output.

Table 5. Truth Table

ADG701L In	ADG702L In	Switch Condition
0	1	Off
1	0	On

TYPICAL PERFORMANCE CHARACTERISTICS

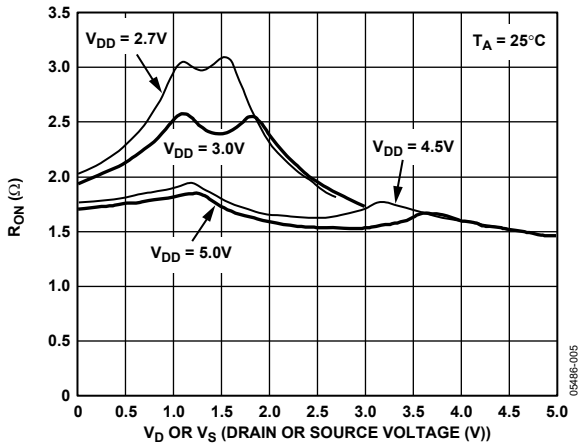

Figure 6. R_{ON} as a Function of V_D (V_S) Single Supplies

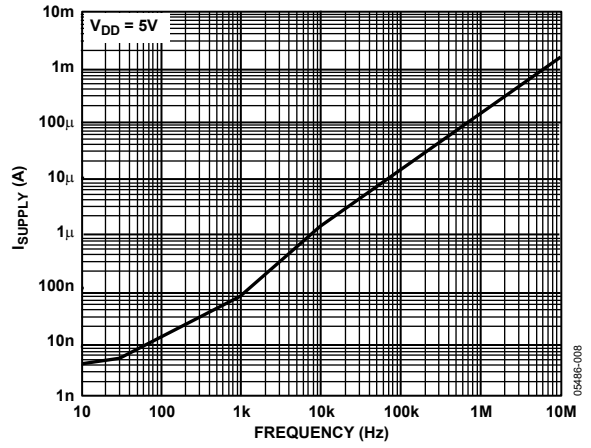

Figure 9. Supply Current (I_{SUPPLY}) vs. Input Switching Frequency

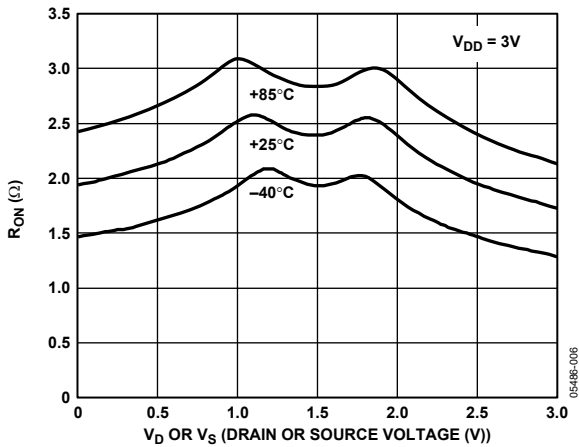

Figure 7. R_{ON} as a Function of V_D (V_S) for Different Temperatures $V_{DD} = 3V$

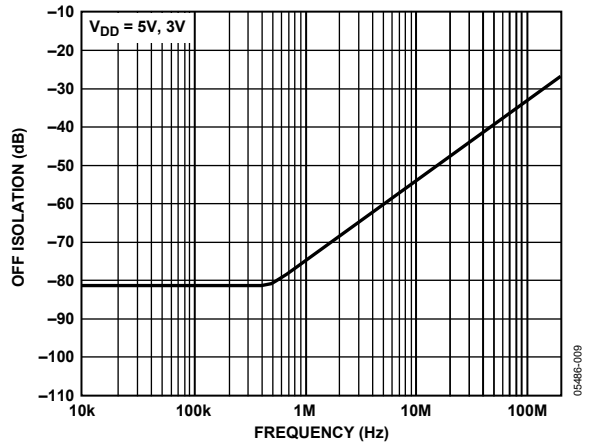

Figure 10. Off Isolation vs. Frequency

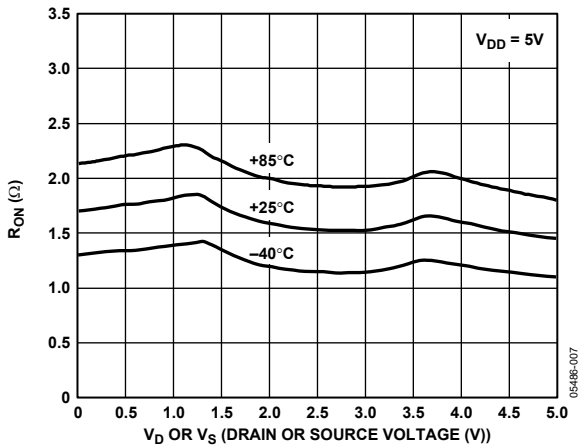

Figure 8. R_{ON} as a Function of V_D (V_S) for Different Temperatures $V_{DD} = 5V$

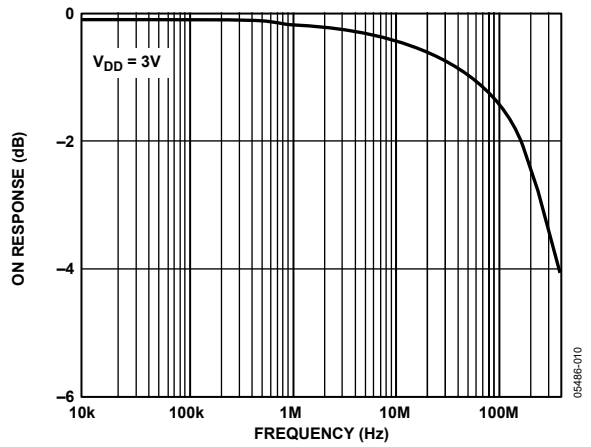

Figure 11. Bandwidth

TEST CIRCUITS

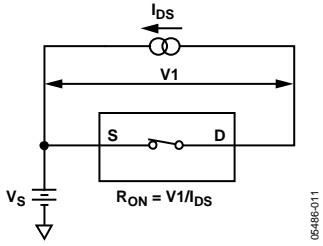

Figure 12. R_{ON}

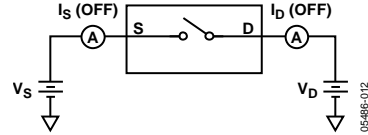

Figure 14. Off Leakage

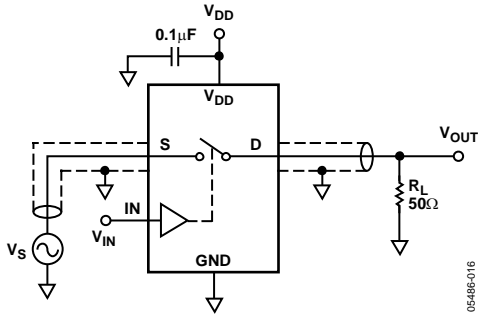

Figure 13. Off Isolation

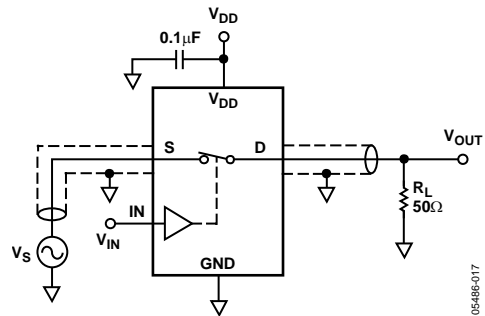

Figure 15. Bandwidth

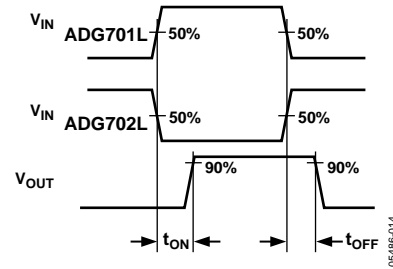
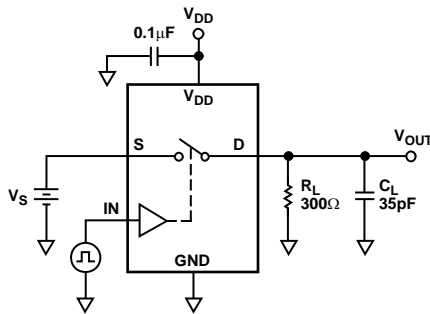

Figure 16. Switching Times

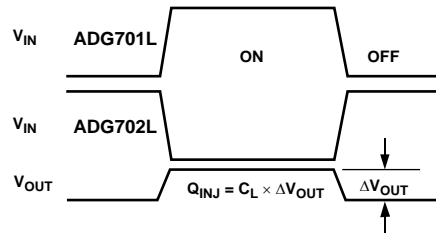
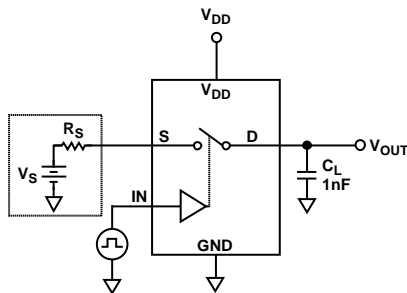

Figure 17. Charge Injection

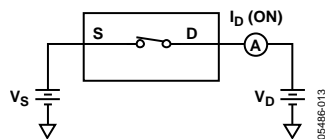

Figure 18. On Leakage

TERMINOLOGY

R_{ON}

Ohmic resistance between D and S.

R_{FLAT(ON)}

Flatness is defined as the difference between the maximum and minimum value of on resistance as measured over the specified analog signal range.

I_S (OFF)

Source leakage current with the switch off.

I_D (OFF)

Drain leakage current with the switch off.

I_D, I_S (ON)

Channel leakage current with the switch on.

V_D (V_S)

Analog voltage on Terminal D and Terminal S.

C_S (OFF)

Off switch source capacitance.

C_D (OFF)

Off switch drain capacitance.

C_D, C_S (ON)

On switch capacitance.

t_{ON}

Delay between applying the digital control input and the output switching on. See Figure 16.

t_{OFF}

Delay between applying the digital control input and the output switching off.

Off Isolation

A measure of unwanted signal coupling through an off switch.

Charge Injection

A measure of the glitch impulse transferred from the digital input to the analog output during switching.

Bandwidth

The frequency at which the output is attenuated by -3 dB.

On Response

The frequency response of the on switch.

On Loss

The voltage drop across the on switch, seen in Figure 11 as the number of decibels the signal is away from 0 dB at very low frequencies.

APPLICATIONS INFORMATION

The ADG701L/ADG702L belong to the Analog Devices new family of CMOS switches. This series of general-purpose switches have improved switching times, lower R_{ON} , higher bandwidth, low power consumption, and low leakage currents.

SUPPLY VOLTAGES

Functionality of the ADG701L/ADG702L extends from 1.8 V to 5.5 V single supply, making the parts ideal for battery-powered instruments where power, efficiency, and performance are important design parameters.

It is important to note that the supply voltage affects the input signal range, the on resistance, and the switching times of the part. The effects of the power supplies can be clearly seen in the Typical Performance Characteristics section and the Specifications section.

For $V_{DD} = 1.8$ V operation, R_{ON} is typically 40 Ω over the temperature range.

BANDWIDTH

Figure 19 illustrates the parasitic components that affect the performance of CMOS switches (a box surrounds the switch). Additional external capacitances further degrade some performance. These capacitances affect feedthrough, crosstalk, and system bandwidth.

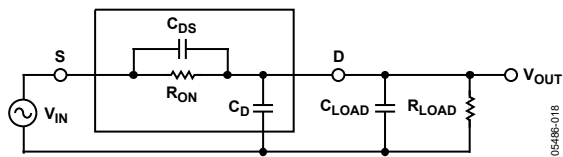

Figure 19. Switch Represented by Equivalent Parasitic Components

The transfer function that describes the equivalent diagram of the switch (see Figure 19) is of the form $A(s)$, as shown in the following equation:

$$A(s) = R_T \left(\frac{s(R_{ON}C_{DS}) + 1}{s(R_{ON}C_T R_T) + 1} \right)$$

and calculate the total capacitance, C_T , with the following equation:

$$C_T = C_{LOAD} + C_D + C_{DS}$$

where C_{DS} is the drain/source capacitance.

The signal transfer characteristic is dependent on the switch channel capacitance, C_{DS} . This capacitance creates a frequency zero in the numerator of the transfer function, $A(s)$. Because the switch on resistance is small, this zero usually occurs at high frequencies. The bandwidth is a function of the switch output capacitance combined with C_{DS} and the load capacitance. The frequency pole corresponding to these capacitances appears in the denominator of $A(s)$.

The dominant effect of the output capacitance, C_D , causes the pole breakpoint frequency to occur first. In order to maximize bandwidth, a switch must have a low input and output capacitance and low on resistance. The on response versus frequency for the ADG701L/ADG702L is shown in Figure 11.

OFF ISOLATION

Off isolation is a measure of the input signal coupled through an off switch to the switch output. The capacitance, C_{DS} , couples the input signal to the output load when the switch is off (see Figure 20).

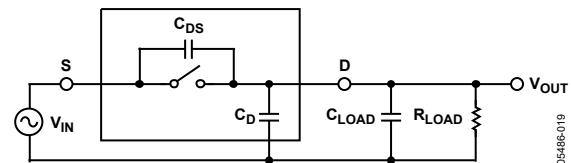
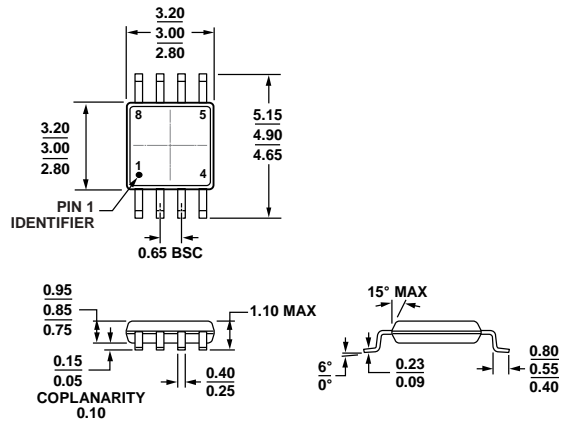

Figure 20. Off Isolation Is Affected by External Load Resistance and Capacitance

The larger the value of C_{DS} , the larger the values of feedthrough produced. Figure 10 illustrates the drop in off isolation as a function of frequency. From dc to roughly 1 MHz, the switch shows better than -75 dB isolation. Up to frequencies of 10 MHz, the off isolation remains better than -55 dB. As the frequency increases, more and more of the input signal is coupled through to the output. Off isolation can be maximized by choosing a switch with the smallest C_{DS} possible. The values of load resistance and capacitance also affect off isolation, as they contribute to the coefficients of the poles and zeros in the transfer function of the switch when open.

$$A(s) = R_T \left(\frac{s(R_{LOAD}C_{DS}) + 1}{s(R_{LOAD})(C_T) + 1} \right)$$

OUTLINE DIMENSIONS



COMPLIANT TO JEDEC STANDARDS MO-187-AA

Figure 21. 8-Lead Mini Small Outline Package [MSOP] (RM-8)

Dimensions shown in millimeters

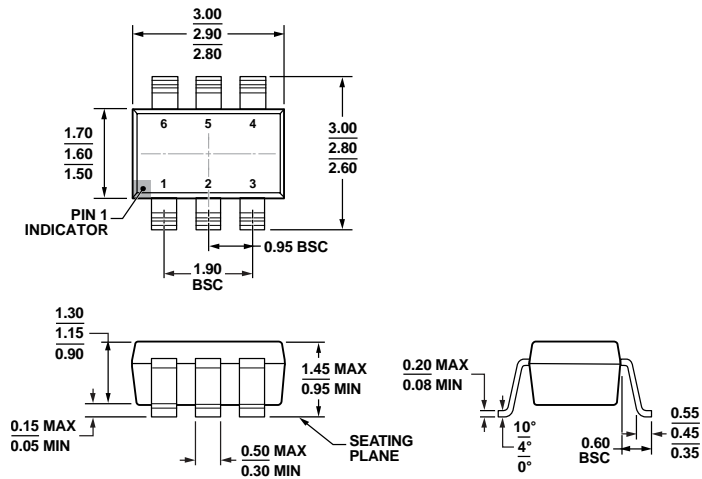

COMPLIANT TO JEDEC STANDARDS MO-178-AB

Figure 22. 6-Lead Small Outline Transistor Package [SOT-23] (RJ-6)

Dimensions shown in millimeters

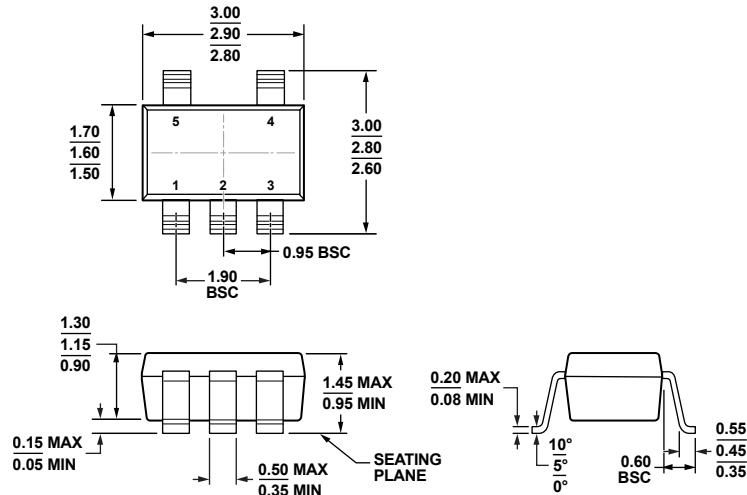

COMPLIANT TO JEDEC STANDARDS MO-178-AA

Figure 23. 5-Lead Small Outline Transistor Package [SOT-23] (RJ-5)

Dimensions shown in millimeters

11-01-2010-A

ORDERING GUIDE

Model ¹	Temperature Range	Package Description	Package Option	Marking Code ²
ADG701LBRJZ-500RL7	-40°C to +85°C	5-Lead Small Outline Transistor Package [SOT-23]	RJ-5	S10
ADG701LBRJZ-REEL7	-40°C to +85°C	5-Lead Small Outline Transistor Package [SOT-23]	RJ-5	S10
ADG701LBRMZ	-40°C to +85°C	8-Lead Mini Small Outline Package [MSOP]	RM-8	S10
ADG701LBRMZ-REEL7	-40°C to +85°C	8-Lead Mini Small Outline Package [MSOP]	RM-8	S10
ADG701LBRTZ-REEL7	-40°C to +85°C	6-Lead Small Outline Transistor Package [SOT-23]	RJ-6	S10
ADG702LBRMZ	-40°C to +85°C	8-Lead Mini Small Outline Package [MSOP]	RM-8	S11
ADG702LBRTZ-REEL7	-40°C to +85°C	6-Lead Small Outline Transistor Package [SOT-23]	RJ-6	S11

¹ Z = RoHS Compliant Part.

² Due to package size limitations, these three characters represent the part number.

Looking for pricing, stock, or lifecycle information?

Click below to explore more details on WIN SOURCE:

- ⊖ [View ADG701LBRJZ-REEL7 on WIN SOURCE](#)
- ⊖ [Analog Devices Inc. Information](#)

Optimize Your Supply Chain with WIN SOURCE Solutions

- ✓ Global Sourcing Solution
- ✓ Obsolete Management
- ✓ Cost Control Management
- ✓ Shortage Management
- ✓ Alternative Solution
- ✓ Excess Inventory Management