



**THE DATASHEET OF
CY8C4126AXI-M443**



Features**32-bit MCU subsystem**

- 24-MHz Arm® Cortex®-M0 CPU with single-cycle multiply
- Up to 128 kB of flash with Read Accelerator
- Up to 16 kB of SRAM
- DMA engine

Programmable analog

- Four opamps that operate in Deep Sleep mode at very low current levels
- All opamps have reconfigurable high current pin-drive, high-bandwidth internal drive, ADC input buffering, and Comparator modes with flexible connectivity allowing input connections to any pin
- Four current DACs (IDACs) for general-purpose or capacitive sensing applications on any pin
- Two low-power comparators that operate in Deep Sleep mode
- 12-bit SAR ADC with 806-Ksps conversion rate

Low-power 1.71 to 5.5 V operation

- 20-nA Stop Mode with GPIO pin wakeup
- Hibernate and Deep Sleep modes allow wakeup-time vs power trade-offs

Capacitive sensing

- Infineon Capacitive Sigma-Delta (CSD) technique provides best-in-class SNR (>5:1) and water tolerance
- Infineon-supplied software component makes capacitive sensing design easy
- Automatic hardware tuning (SmartSense)

Segment LCD drive

- LCD drive supported on all pins (common or segment)
- Operates in Deep Sleep mode with 4 bits per pin memory

Serial communication

- Four independent run-time reconfigurable serial communication blocks (SCBs) with reconfigurable I2C, SPI, or UART functionality

Timing and pulse-width modulation

- Eight 16-bit timer/counter pulse-width modulator (TCPWM) blocks
- Center-aligned, Edge, and Pseudo-random modes
- Comparator-based triggering of Kill signals for motor drive and other high-reliability digital logic applications

Package options

- 68-pin QFN, 64-pin TQFP wide and narrow pitch, and 48-pin and 44-pin TQFP packages
- Up to 55 programmable GPIOs
- GPIO pins can be CAPSENSE™, LCD, analog, or digital
- Drive modes, strengths, and slew rates are programmable

Extended industrial temperature operation

- -40°C to +105°C operation

PSoC™ Creator design environment

- Integrated Development Environment (IDE) provides schematic design entry and build (with analog and digital automatic routing)
- Applications Programming Interface (API component) for all fixed-function and programmable peripherals

Industry-standard tool compatibility

- After schematic entry, development can be done with Arm®-based industry-standard development tools

Description

PSoC™ 4 is a scalable and reconfigurable platform architecture for a family of programmable embedded system controllers with an Arm® Cortex® -M0 CPU. It combines programmable and reconfigurable analog and digital blocks with flexible automatic routing. The PSoC™ 4100M product family, based on this platform architecture, is a combination of a microcontroller with digital programmable logic, programmable analog, programmable interconnect, high-performance analog-to-digital conversion, opamps with comparator mode, and standard communication and timing peripherals. The PSoC™ 4100M products will be fully compatible with members of the PSoC™ 4 platform for new applications and design needs. The programmable analog and digital subsystems allow flexibility and in-field tuning of the design.

Table of contents

	Features	1
	Description	2
	Table of contents	3
1	Development ecosystem	5
1.1	PSoC™ 4 resources	5
1.2	PSoC™ Creator	5
2	Block diagram	7
3	Functional definition	9
3.1	CPU and memory subsystem	9
3.1.1	CPU	9
3.1.2	Flash	9
3.1.3	SRAM	9
3.1.4	SROM	9
3.1.5	DMA	9
3.2	System resources	9
3.2.1	Power system	9
3.2.2	Clock system	10
3.2.3	IMO clock source	10
3.2.4	ILO clock source	10
3.2.5	Crystal oscillator	10
3.2.6	Watchdog timer	11
3.2.7	Reset	11
3.2.8	Voltage reference	11
3.3	Analog blocks	11
3.3.1	12-bit SAR ADC	11
3.3.2	Analog multiplex bus	12
3.3.3	Four opamps	12
3.3.4	Temperature sensor	13
3.3.5	Low-power comparators	14
3.4	Fixed function digital	14
3.4.1	Timer/Counter/PWM (TCPWM) block	14
3.4.2	Serial communication blocks (SCB)	14
3.5	GPIO	15
3.6	Special function peripherals	15
3.6.1	LCD segment drive	15
3.6.2	CAPSENSE™	15
4	Pinouts	17

5	Power	23
5.1	Unregulated external supply	23
5.2	Regulated external supply	23
6	Electrical specifications	24
6.1	Absolute maximum ratings	24
6.2	Device level specifications	24
6.2.1	GPIO	27
6.2.2	XRES	28
6.3	Analog peripherals	29
6.3.1	Opamp	29
6.3.2	Comparator	34
6.3.3	Temperature sensor	35
6.3.4	SAR ADC	36
6.3.5	CSD	37
6.4	Digital peripherals	38
6.4.1	Timer/Counter/PWM	38
6.4.2	I2C	39
6.4.3	LCD direct drive	40
6.4.4	SPI specifications	41
6.5	Memory	42
6.6	System resources	42
6.6.1	Power-on reset (POR) with Brown Out	42
6.6.2	Voltage monitors	43
6.6.3	SWD interface	44
6.6.4	Internal main oscillator	44
6.6.5	Internal low-speed oscillator	45
7	Ordering information	47
7.1	Part numbering conventions	48
8	Packaging	49
9	Acronyms	54
10	Document conventions	58
10.1	Units of measure	58
11	Revision history	60
	Disclaimer	61

1 Development ecosystem

1.1 PSoC™ 4 resources

Infineon provides a wealth of data at www.infineon.com to help you select the right PSoC™ device and quickly and effectively integrate it into your design. The following is an abbreviated, hyperlinked list of resources for PSoC™ 4 MCU:

- Overview: [PSoC™ portfolio](#).
- Product selector: [PSoC™ 4 MCU](#)
- [Application Notes](#) cover a broad range of topics, from basic to advanced level, and include the following:
 - [AN79953](#): Getting Started with PSoC™ 4
 - [AN88619](#): PSoC™ Hardware Design Considerations.
 - [AN73854](#): PSoC™ - Introduction to Bootloaders
 - [AN89610](#): Arm® Cortex® Code Optimization
 - [AN86233](#): PSoC™ 4 MCU Power Reduction Techniques
 - [AN57821](#): Mixed Signal Circuit Board Layout.
 - [AN85951](#): PSoC™ 4 and PSoC™ 6 MCU CapSense Design Guide.
- [Code Examples](#) demonstrate product features and usage, and are also available on [GitHub repositories](#)
- [Technical reference manuals \(TRM\)](#) provide detailed descriptions of architecture and registers in each device family.
- [PSoC™ 4 MCU Programming Specification](#) provides the information necessary to program PSoC™ 4 MCU non-volatile memory.
- Development Tools
 - [PSoC™ Creator](#) is a free Windows-based IDE. It enables concurrent hardware and firmware design of PSoC™ 3, PSoC™ 4, PSoC™ 5LP, and PSoC™ 6 MCU based systems. Applications are created using schematic capture and over 150 preverified, production-ready peripheral Components
 - [CY8CKIT-044](#) is a PSoC™ 4 Pioneer kits that is easy-to-use and an inexpensive development platforms. These include connectors for Arduino-compatible shields and Digilent Pmod daughter cards.
 - [CY8CKIT-043](#) is a very low-cost prototyping platform for sampling PSoC™ 4200M device.
 - [MiniProg4](#) and [MiniProg3](#) all-in-one development programmers and debuggers.
 - [PSoC™ 4 MCU CAD libraries](#) provide footprint and schematic support for common tools. [IBIS models](#) are also available.
- [Training videos](#) are available on a wide range of topics including the [PSoC™ MCUs](#).
- [Infineon Developer Community](#) enables connection with fellow PSoC™ developers around the world, 24 hours a day, 7 days a week, and hosts a dedicated [PSoC™ 4 MCU community](#).

1.2 PSoC™ Creator

[PSoC™ Creator](#) is a free Windows-based Integrated Design Environment (IDE). It enables you to design hardware and firmware systems concurrently, based on PSoC™ 4 MCU. As [Figure 1](#) shows, with PSoC™ Creator you can:

1. Explore the library of 200+ components.
2. Drag and drop component icons to complete your hardware system design in the main design workspace.
3. Configure Components using the Component configuration tools and the Component datasheets.
4. Co-design your application firmware and hardware in the PSoC™ Creator IDE or build a project for a third-party IDE.
5. Prototype your solution with the PSoC™ 4 Pioneer kits. If a design change is needed, PSoC™ Creator and Components enable you to make changes on-the-fly without the need for hardware revisions.

1 Development ecosystem

For information on Infineon tools, refer to the documentation delivered with PSoC™ Creator software, and [AN79953: Getting started with PSoC™ 4](#).

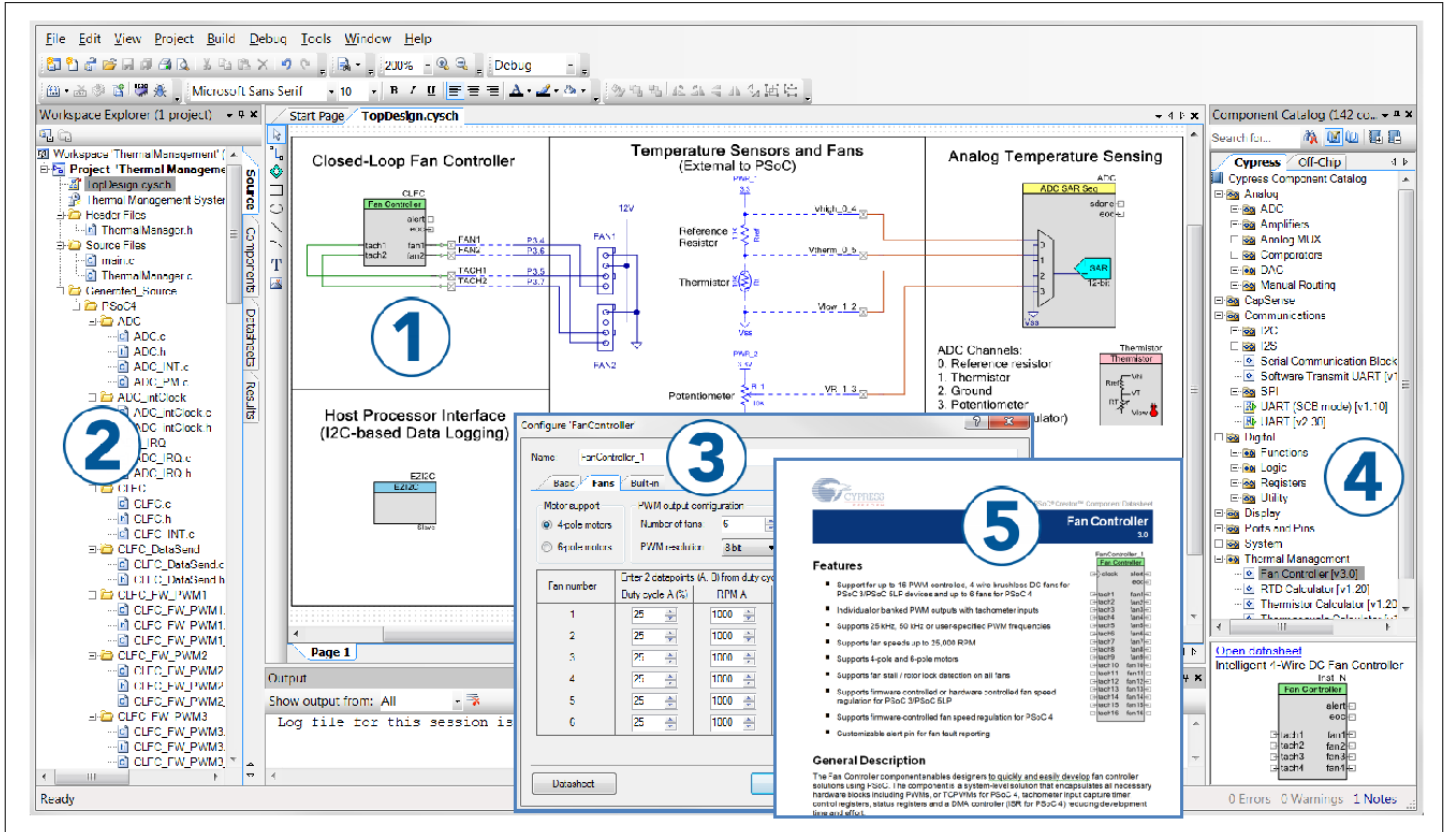

Figure 1 Multiple-sensor example project in PSoC™ Creator

2 Block diagram

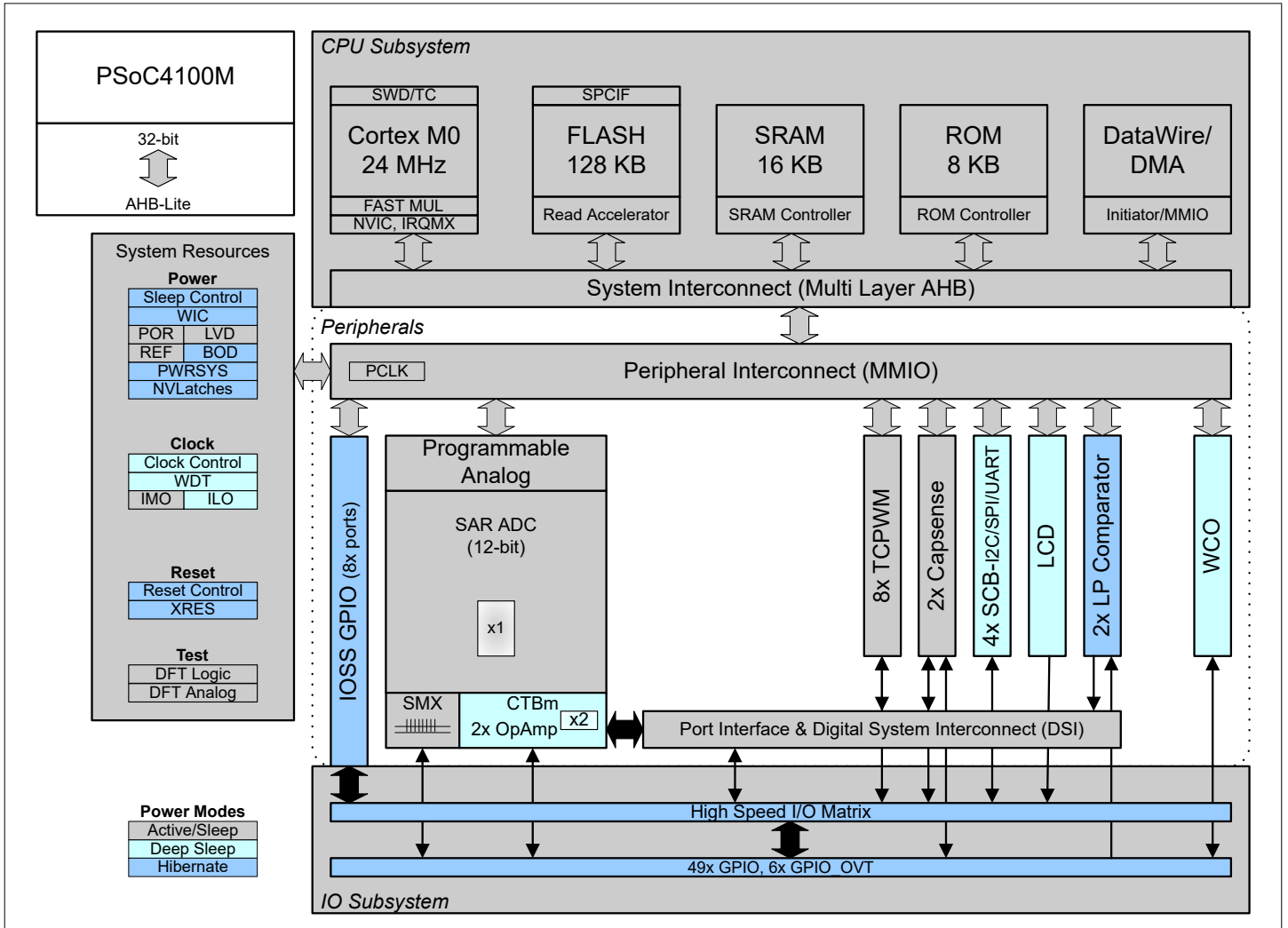

Figure 2 Block diagram

The PSoc™ 4100-M devices include extensive support for programming, testing, debugging, and tracing both hardware and firmware.

The Arm® Serial_Wire Debug (SWD) interface supports all programming and debug features of the device.

Complete debug-on-chip functionality enables full-device debugging in the final system using the standard production device. It does not require special interfaces, debugging pods, simulators, or emulators. Only the standard programming connections are required to fully support debug.

The PSoc™ Creator IDE provides fully-integrated programming and debug support for PSoc™ 4100-M devices. The SWD interface is fully compatible with industry-standard third-party tools. PSoc™ 4100-M provides a level of security not possible with multichip application solutions or with microcontrollers. This is due to its ability to disable debug features, robust flash protection, and because it allows customer-proprietary functionality to be implemented in on-chip programmable blocks.

The debug circuits are enabled by default and can only be disabled in the firmware. If not enabled, the only way to re-enable them is to erase the entire device, clear flash protection, and reprogram the device with new firmware that enables debugging.

Additionally, all device interfaces can be permanently disabled (device security) for applications concerned about phishing attacks due to a maliciously reprogrammed device or attempts to defeat security by starting and interrupting flash programming sequences. Because all programming, debug, and test interfaces are disabled when

maximum device security is enabled, PSoC™ 4100-M with device security enabled may not be returned for failure analysis. This is a trade-off the PSoC™ 4100-M allows the customer to make.

3 Functional definition

3.1 CPU and memory subsystem

3.1.1 CPU

The Cortex®-M0 CPU in the PSoC™ 4100-M is part of the 32-bit MCU subsystem, which is optimized for low-power operation with the extensive clock gating. Most instructions are 16 bits in length and execute a subset of the Thumb-2 instruction set. The Infineon implementation includes a hardware multiplier that provides a 32-bit result in one cycle. It includes a nested vectored interrupt controller (NVIC) block with 32 interrupt inputs and also includes a Wakeup Interrupt Controller (WIC), which can wake the processor up from the Deep Sleep mode allowing power to be switched off to the main processor when the chip is in the Deep Sleep mode. The Cortex®-M0 CPU provides a Non-Maskable Interrupt (NMI) input, which is made available to the user when it is not in use for system functions requested by the user.

The CPU also includes a debug interface, the serial wire debug (SWD) interface, which is a 2-wire form of JTAG; the debug configuration used for PSoC™ 4100-M has four break-point (address) comparators and two watchpoint (data) comparators.

3.1.2 Flash

The PSoC™ 4100-M has a flash module with a flash accelerator, tightly coupled to the CPU to improve average access times from the flash block. The flash accelerator delivers 85% of single-cycle SRAM access performance on average. Part of the flash module can be used to emulate EEPROM operation if required.

3.1.3 SRAM

The SRAM memory is retained during Hibernate.

3.1.4 SROM

A supervisory ROM that contains boot and configuration routines is provided.

3.1.5 DMA

A DMA engine, with eight channels, is provided that can do 32-bit transfers and has chainable ping-pong descriptors.

3.2 System resources

3.2.1 Power system

The power system is described in detail in the section [Power](#). It provides assurance that voltage levels are as required for each respective mode and either delay mode entry (for example, on power-on reset (POR)) until voltage levels are as required for proper function or generate resets (brownout detect (BOD)) or interrupts (low voltage detect (LVD)). The PSoC™ 4100M operates with a single external supply over the range of 1.71 to 5.5 V and has five different power modes, transitions between which are managed by the power system. The PSoC™ 4100M provides Sleep, Deep Sleep, Hibernate, and Stop low-power modes.

3.2.2 Clock system

The PSoC™ 4100-M clock system is responsible for providing clocks to all subsystems that require clocks and for switching between different clock sources without glitching. In addition, the clock system ensures that no meta-stable conditions occur.

The clock system for the PSoC™ 4100-M consists of a Watch Crystal Oscillator (WCO) running at 32 kHz, the IMO (3 to 48 MHz) and the ILO (32-kHz nominal) internal oscillators, and provision for an external clock.

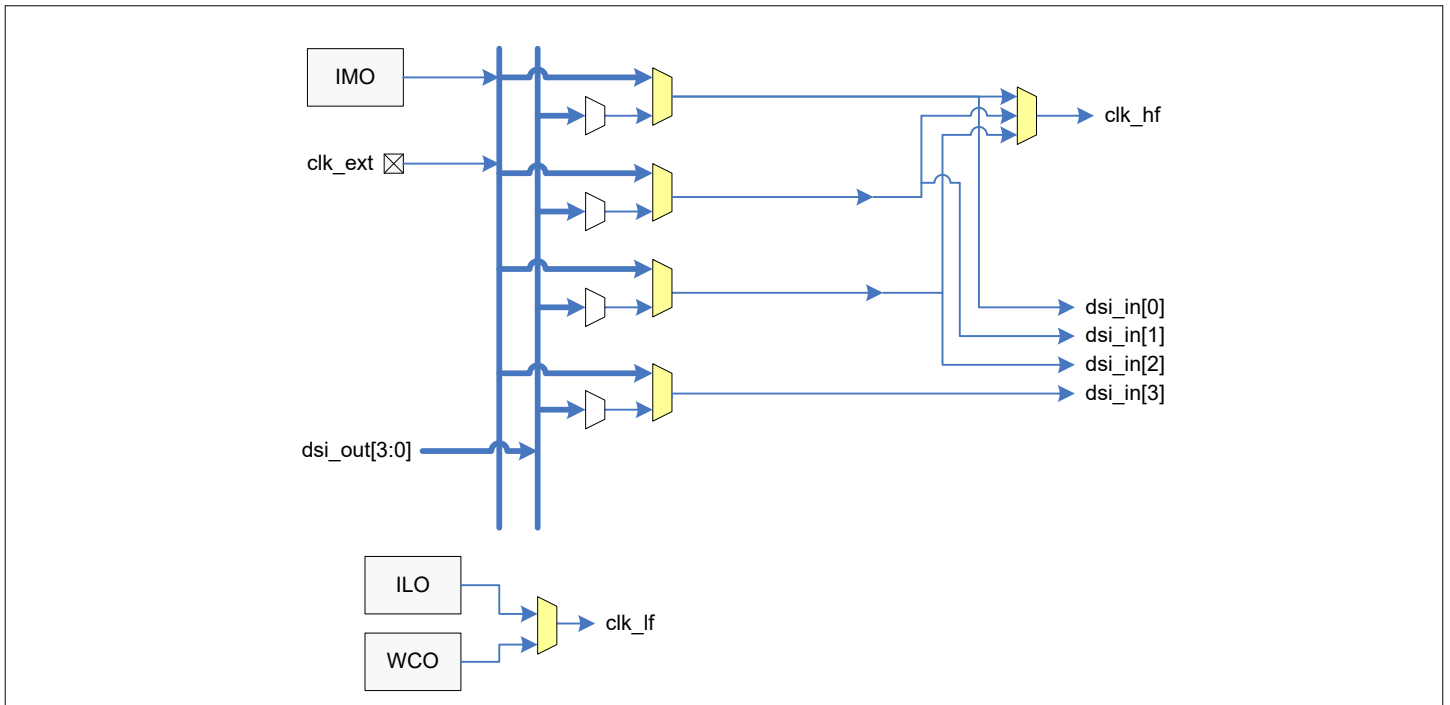

Figure 3 PSoC™ 4100M MCU clocking architecture

The clk_hf signal can be divided down to generate synchronous clocks for the UDBs, and the analog and digital peripherals. There are a total of 16 clock dividers for the PSoC™ 4100-M, each with 16-bit divide capability; this allows 12 to be used for the fixed-function blocks and four for the UDBs. The analog clock leads the digital clocks to allow analog events to occur before digital clock-related noise is generated. The 16-bit capability allows a lot of flexibility in generating fine-grained frequency values and is fully supported in PSoC™ Creator.

3.2.3 IMO clock source

The IMO is the primary source of internal clocking in the PSoC™ 4100M. It is trimmed during testing to achieve the specified accuracy. Trim values are stored in non-volatile memory. Trimming can also be done on the fly to allow in-field calibration. The IMO default frequency is 24 MHz and it can be adjusted between 3 to 48 MHz in steps of 1 MHz. IMO tolerance with Infineon-provided calibration settings is ±2%.

3.2.4 ILO clock source

The ILO is a very low-power oscillator, nominally 32 kHz, which is primarily used to generate clocks for peripheral operation in Deep Sleep mode. The ILO-driven counters can be calibrated to the IMO to improve accuracy. Infineon provides a software component, which does the calibration.

3.2.5 Crystal oscillator

The PSoC™ 4100M clock subsystem also includes a low-frequency crystal oscillator (32-kHz WCO) that is available during the Deep Sleep mode and can be used for Real-Time Clock (RTC) and Watchdog Timer applications.

3.2.6 Watchdog timer

A watchdog timer is implemented in the clock block running from the low-frequency clock; this allows watchdog operation during Deep Sleep and generates a watchdog reset or an interrupt if not serviced before the timeout occurs. The watchdog reset is recorded in the Reset Cause register.

3.2.7 Reset

The PSoC™ 4100M can be reset from a variety of sources including a software reset. Reset events are asynchronous and guarantee reversion to a known state. The reset cause is recorded in a register, which is sticky through reset and allows software to determine the cause of the reset. An XRES pin is reserved for external reset to avoid complications with configuration and multiple pin functions during power-on or reconfiguration.

3.2.8 Voltage reference

The PSoC™ 4100M reference system generates all internally required references. A 1% voltage reference spec is provided for the 12-bit ADC. To allow better signal-to-noise ratios (SNR) and better absolute accuracy, it is possible to add an external bypass capacitor to the internal reference using a GPIO pin or to use an external reference for the SAR.

3.3 Analog blocks

3.3.1 12-bit SAR ADC

The 12-bit SAR ADC can operate at a maximum sample rate of 806 Ksamples/second.

The block functionality is augmented for the user by adding a reference buffer to it (trimmable to $\pm 1\%$) and by providing the choice of three internal voltage references: V_{DD} , $V_{DD}/2$, and V_{REF} (nominally 1.024 V) as well as an external reference through a GPIO pin. The Sample-and-Hold (S/H) aperture is programmable allowing the gain bandwidth requirements of the amplifier driving the SAR inputs, which determine its settling time, to be relaxed if required. The system performance will be 65 dB for true 12-bit precision if appropriate references are used and system noise levels permit. To improve performance in noisy conditions, it is possible to provide an external bypass (through a fixed pin location) for the internal reference amplifier.

The SAR is connected to a fixed set of pins through an 8-input sequencer (expandable to 16 inputs). The sequencer cycles through selected channels autonomously (sequencer scan) and does so with zero switching overhead (that is, the aggregate sampling bandwidth is equal to 1 Msps, whether it is for a single channel or distributed over several channels). The sequencer switching is effected through a state machine or through firmware-driven switching. A feature provided by the sequencer is buffering of each channel to reduce CPU interrupt service requirements. To accommodate signals with varying source impedance and frequency, it is possible to have different sample times programmable for each channel. In addition, the signal range specification through a pair of range registers (low and high range values) is implemented with a corresponding out-of-range interrupt if the digitized value exceeds the programmed range; this allows fast detection of out-of-range values without the necessity of having to wait for a sequencer scan to be completed and the CPU to read the values and check for out-of-range values in software.

The SAR is able to digitize the output of the on-board temperature sensor for calibration and other temperature-dependent functions. The SAR is not available in Deep Sleep and Hibernate modes as it requires a high-speed clock. The SAR operating range is 1.71 to 5.5 V.

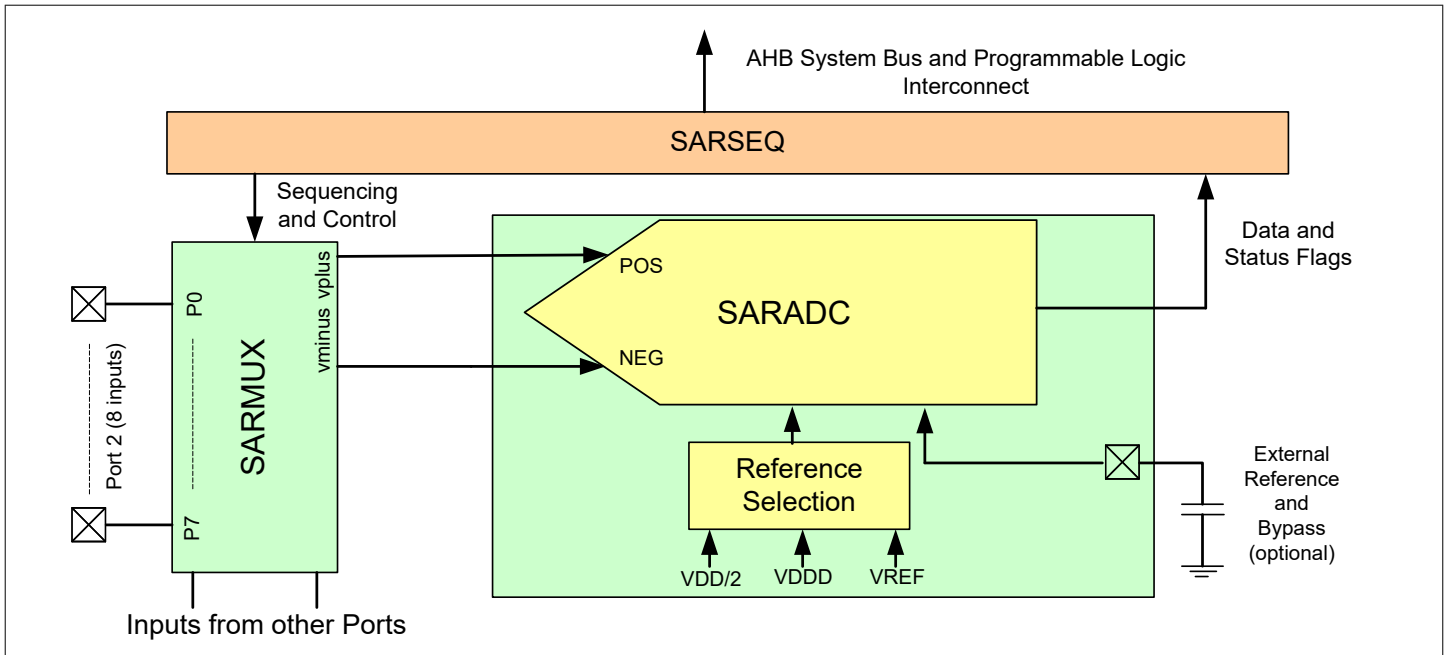

Figure 4 SAR ADC system diagram

3.3.2 Analog multiplex bus

The PSoC™ 4100M has two concentric analog buses (Analog Mux Bus A and Analog Mux Bus B) that circumnavigate the periphery of the chip. These buses can transport analog signals from any pin to various analog blocks (including the opamps) and to the CAPSENSE™ blocks allowing, for instance, the ADC to monitor any pin on the chip. These buses are independent and can also be split into three independent sections. This allows one section to be used for CAPSENSE™ purposes, one for general analog signal processing, and the third for general-purpose digital peripherals and GPIO.

3.3.3 Four opamps

The PSoC™ 4100M has four opamps with comparator modes, which allow most common analog functions to be performed on-chip eliminating external components; PGAs, voltage buffers, filters, trans-impedance amplifiers, and other functions can be realized with external passives saving power, cost, and space. The on-chip opamps are designed with enough bandwidth to drive the Sample-and-Hold circuit of the ADC without requiring external buffering. The opamps can operate in the Deep Sleep mode at very low power levels. The following diagram shows one of two identical opamp pairs of the opamp subsystem.

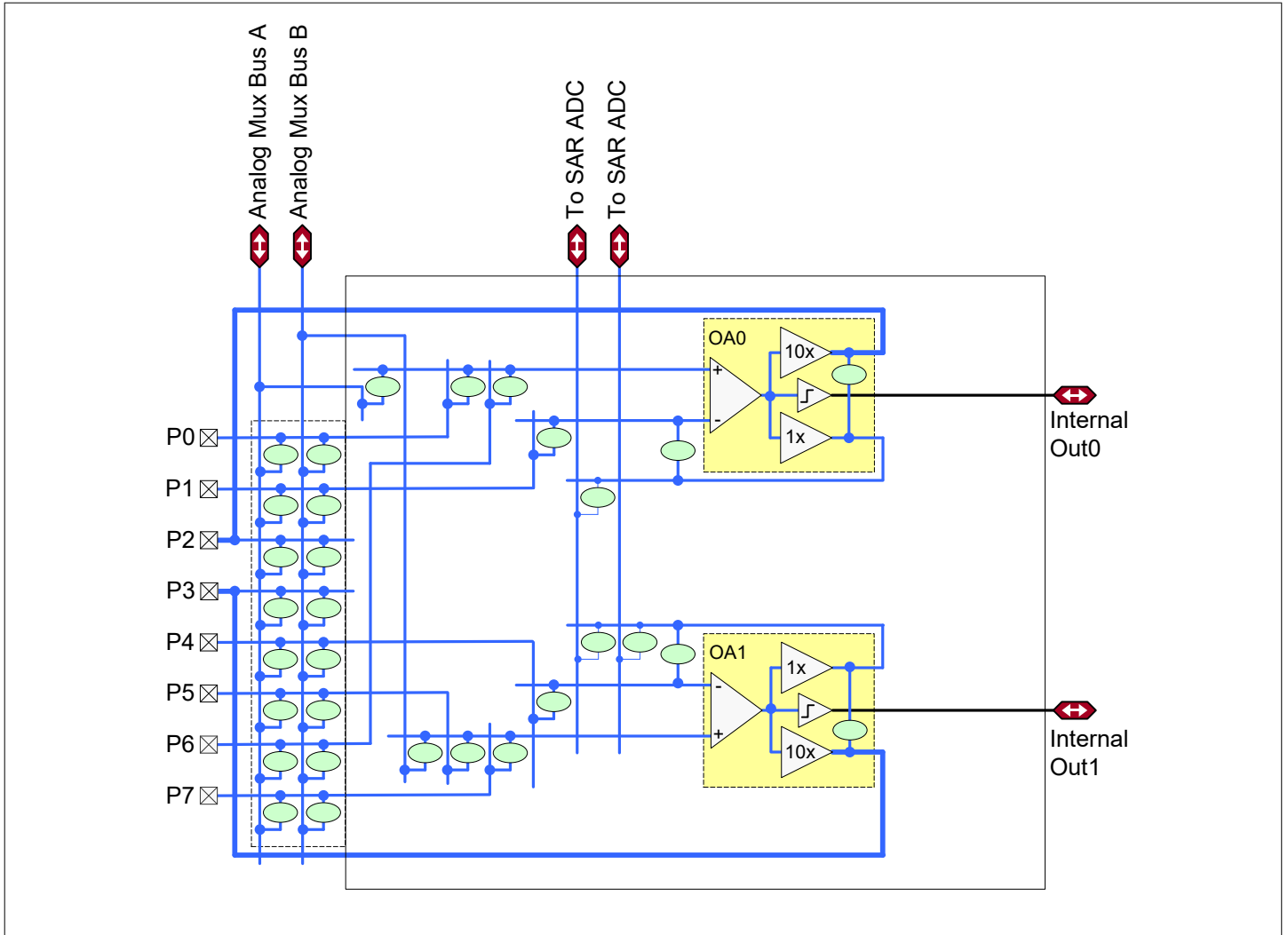

Figure 5 Identical opamp pairs in opamp subsystem

The ovals in Figure 5 represent analog switches, which may be controlled via user firmware, the SAR sequencer, or user-defined programmable logic. The opamps (OA0 and OA1) are configurable via these switches to perform all standard opamp functions with appropriate feedback components.

The opamps (OA0 and OA1) are programmable and reconfigurable to provide standard opamp functionality via switchable feedback components, unity gain functionality for driving pins directly, or for internal use (such as buffering SAR ADC inputs as indicated in the diagram), or as true comparators.

The opamp inputs provide highly flexible connectivity and can connect directly to dedicated pins or, via the analog mux buses, to any pin on the chip. Analog switch connectivity is controllable by user firmware.

The opamps operate in Deep Sleep mode at very low currents allowing analog circuits to remain operational during Deep Sleep.

3.3.4 Temperature sensor

The PSoC™ 4100M has one on-chip temperature sensor. This consists of a diode, which is biased by a current source that can be disabled to save power. The temperature sensor is connected to the ADC, which digitizes the reading and produces a temperature value using Infineon-supplied software that includes calibration and linearization.

3.3.5 Low-power comparators

The PSoC™ 4100M has a pair of low-power comparators, which can also operate in the Deep Sleep and Hibernate modes. This allows the analog system blocks to be disabled while retaining the ability to monitor external voltage levels during low-power modes. The comparator outputs are normally synchronized to avoid meta-stability unless operating in an asynchronous power mode (Hibernate) where the system wake-up circuit is activated by a comparator switch event.

3.4 Fixed function digital

3.4.1 Timer/Counter/PWM (TCPWM) block

The TCPWM block uses a 16-bit counter with user-programmable period length. There is a Capture register to record the count value at the time of an event (which may be an I/O event), a period register which is used to either stop or auto-reload the counter when its count is equal to the period register, and compare registers to generate compare value signals, which are used as PWM duty cycle outputs. The block also provides true and complementary outputs with programmable offset between them to allow use as deadband programmable complementary PWM outputs. It also has a Kill input to force outputs to a predetermined state; for example, this is used in motor drive systems when an overcurrent state is indicated and the PWMs driving the FETs need to be shut off immediately with no time for software intervention. The PSoC™ 4100M has eight TCPWM blocks.

3.4.2 Serial communication blocks (SCB)

The PSoC™ 4100M has four SCBs, which can each implement an I²C, UART, or SPI interface.

I²C Mode: The hardware I²C block implements a full multi-master and slave interface (it is capable of multimaster arbitration). This block is capable of operating at speeds of up to 1 Mbps (Fast Mode Plus) and has flexible buffering options to reduce interrupt overhead and latency for the CPU. It also supports EzI²C that creates a mailbox address range in the memory of the PSoC™ 4100M and effectively reduces I²C communication to reading from and writing to an array in memory. In addition, the block supports an 8-deep FIFO for receive and transmit which, by increasing the time given for the CPU to read data, greatly reduces the need for clock stretching caused by the CPU not having read data on time. The FIFO mode is available in all channels and is very useful in the absence of DMA.

The I²C peripheral is compatible with the I²C Standard-mode, Fast-mode, and Fast-mode Plus devices as defined in the NXP I²C-bus specification and user manual (UM10204). The I²C bus I/O is implemented with GPIO in open-drain modes.

UART Mode: This is a full-feature UART operating at up to 1 Mbps. It supports automotive single-wire interface (LIN), infrared interface (IrDA), and SmartCard (ISO7816) protocols, all of which are minor variants of the basic UART protocol. In addition, it supports the 9-bit multiprocessor mode that allows addressing of peripherals connected over common RX and TX lines. Common UART functions such as parity error, break detect, and frame error are supported. An 8-deep FIFO allows much greater CPU service latencies to be tolerated.

SPI Mode: The SPI mode supports full Motorola SPI, TI SSP (essentially adds a start pulse used to synchronize SPI Codecs), and National Microwire (half-duplex form of SPI). The SPI block can use the FIFO and also supports an EzSPI mode in which data interchange is reduced to reading and writing an array in memory.

3.5 GPIO

The PSoC™ 4100M has 55 GPIOs in the 68-pin QFN package. The GPIO block implements the following:

- Eight drive strength modes including strong push-pull, resistive pull-up and pull-down, weak (resistive) pull-up and pull-down, open drain and open source, input only, and disabled
- Input threshold select (CMOS or LVTTTL)
- Individual control of input and output disables
- Hold mode for latching previous state (used for retaining I/O state in Deep Sleep mode and Hibernate modes)
- Selectable slew rates for dV/dt related noise control to improve EMI

The pins are organized in logical entities called ports, which are 8-bit in width. During power-on and reset, the blocks are forced to the disable state so as not to crowbar any inputs and/or cause excess turn-on current. A multiplexing network known as a high-speed I/O matrix is used to multiplex between various signals that may connect to an I/O pin. Pin locations for fixed-function peripherals are also fixed to reduce internal multiplexing complexity.

Data output and pin state registers store, respectively, the values to be driven on the pins and the states of the pins themselves.

Every I/O pin can generate an interrupt if so enabled and each I/O port has an interrupt request (IRQ) and interrupt service routine (ISR) vector associated with it (8 for PSoC™ 4100M).

The Pins of Port 6 (up to 6 depending on the package) are overvoltage tolerant (V_{IN} can exceed V_{DD}). The overvoltage cells will not sink more than 10 μA when their inputs exceed V_{DDIO} in compliance with I²C specifications.

3.6 Special function peripherals

3.6.1 LCD segment drive

The PSoC™ 4100M has an LCD controller, which can drive up to four commons and up to 51 segments. Any pin can be either a common or a segment pin. It uses full digital methods to drive the LCD segments requiring no generation of internal LCD voltages. The two methods used are referred to as digital correlation and PWM.

Digital correlation pertains to modulating the frequency and levels of the common and segment signals to generate the highest RMS voltage across a segment to light it up or to keep the RMS signal zero. This method is good for STN displays but may result in reduced contrast with TN (cheaper) displays.

PWM pertains to driving the panel with PWM signals to effectively use the capacitance of the panel to provide the integration of the modulated pulse-width to generate the desired LCD voltage. This method results in higher power consumption but can result in better results when driving TN displays. LCD operation is supported during Deep Sleep refreshing a small display buffer (4 bits; 1 32-bit register per port).

3.6.2 CAPSENSE™

CAPSENSE™ is supported on all pins in the PSoC™ 4100M through a Capacitive Sigma-Delta (CSD) block that can be connected to any pin through an analog mux bus that any GPIO pin can be connected to via an Analog switch. CAPSENSE™ functionality can thus be provided on any pin or group of pins in a system under software control. A component is provided for the CAPSENSE™ block, which provides automatic hardware tuning (Infineon SmartSense), to make it easy for the user.

Shield voltage can be driven on another Mux Bus to provide water tolerance capability. Water tolerance is provided by driving the shield electrode in phase with the sense electrode to keep the shield capacitance from attenuating the sensed input.

Each CSD block has two IDACs which can be used for general purposes if CAPSENSE™ is not being used. (both IDACs are available in that case) or if CAPSENSE™ is used without water tolerance (one IDAC is available). The PSoC™ 4100M has two CSD blocks which can be used independently; one for CAPSENSE™ and the other for IDACs.

The two CAPSENSE™ blocks are referred to as CSD0 and CSD1. Capacitance sensing inputs on Ports 0, 1, 2, 3, 4, 6, and 7 are sensed by CSD0. Capacitance sensing inputs on Port 5 are sensed by CSD1.

4 Pinouts

The following is the pin list for the PSoC™ 4100M. This shows the power supply and port pins (for example, P0.0 is Pin 0 of Port 0).

68-QFN		64-TQFP		48-TQFP		44-TQFP	
Pin	Name	Pin	Name	Pin	Name	Pin	Name
42	P0.0	39	P0.0	28	P0.0	24	P0.0
43	P0.1	40	P0.1	29	P0.1	25	P0.1
44	P0.2	41	P0.2	30	P0.2	26	P0.2
45	P0.3	42	P0.3	31	P0.3	27	P0.3
46	P0.4	43	P0.4	32	P0.4	28	P0.4
47	P0.5	44	P0.5	33	P0.5	29	P0.5
48	P0.6	45	P0.6	34	P0.6	30	P0.6
49	P0.7	46	P0.7	35	P0.7	31	P0.7
50	XRES	47	XRES	36	XRES	32	XRES
51	VCCD	48	VCCD	37	VCCD	33	VCCD
52	VSSD	49	VSSD	38	VSSD	–	–
53	VDDD	50	VDDD	39	VDDD	34	VDDD
–	–	–	–	40	VDDA	35	VDDA
62	P1.0	58	P1.0	42	P1.0	37	P1.0
63	P1.1	59	P1.1	43	P1.1	38	P1.1
64	P1.2	60	P1.2	44	P1.2	39	P1.2
65	P1.3	61	P1.3	45	P1.3	40	P1.3
66	P1.4	62	P1.4	46	P1.4	41	P1.4
67	P1.5	63	P1.5	47	P1.5	42	P1.5
68	P1.6	64	P1.6	48	P1.6	43	P1.6
1	P1.7/VREF	1	P1.7/VREF	1	P1.7/VREF	44	P1.7/VREF
–	–	–	–	–	–	1	VSSD
2	P2.0	2	P2.0	2	P2.0	2	P2.0
3	P2.1	3	P2.1	3	P2.1	3	P2.1
4	P2.2	4	P2.2	4	P2.2	4	P2.2
5	P2.3	5	P2.3	5	P2.3	5	P2.3
6	P2.4	6	P2.4	6	P2.4	6	P2.4
7	P2.5	7	P2.5	7	P2.5	7	P2.5
8	P2.6	8	P2.6	8	P2.6	8	P2.6
9	P2.7	9	P2.7	9	P2.7	9	P2.7
10	VSSA	10	VSSA	10	VSSD	10	VSSD
11	VDDA	11	VDDA	–	–	–	–

4 Pinouts

68-QFN		64-TQFP		48-TQFP		44-TQFP	
Pin	Name	Pin	Name	Pin	Name	Pin	Name
19	P3.0	18	P3.0	12	P3.0	11	P3.0
20	P3.1	19	P3.1	13	P3.1	12	P3.1
21	P3.2	20	P3.2	14	P3.2	13	P3.2
22	P3.3	21	P3.3	16	P3.3	14	P3.3
23	P3.4	22	P3.4	17	P3.4	15	P3.4
24	P3.5	23	P3.5	18	P3.5	16	P3.5
25	P3.6	24	P3.6	19	P3.6	17	P3.6
26	P3.7	25	P3.7	20	P3.7	18	P3.7
27	VDDIO	26	VDDIO	21	VDDIO	19	VDDD
28	P4.0	27	P4.0	22	P4.0	20	P4.0
29	P4.1	28	P4.1	23	P4.1	21	P4.1
30	P4.2	29	P4.2	24	P4.2	22	P4.2
31	P4.3	30	P4.3	25	P4.3	23	P4.3
32	P4.4	31	P4.4	-	-	-	-
33	P4.5	32	P4.5	-	-	-	-
34	P4.6	33	P4.6	-	-	-	-
35	P4.7	-	-	-	-	-	-
54	P5.0	51	P5.0	-	-	-	-
55	P5.1	52	P5.1	-	-	-	-
56	P5.2	53	P5.2	-	-	-	-
57	P5.3	54	P5.3	-	-	-	-
58	P5.4	-	-	-	-	-	-
59	P5.5	55	P5.5	-	-	-	-
60	VDDA	56	VDDA	40	VDDA	35	VDDA
61	VSSA	57	VSSA	41	VSSA	36	VSSA
12	P6.0	12	P6.0	-	-	-	-
13	P6.1	13	P6.1	-	-	-	-
14	P6.2	14	P6.2	-	-	-	-
15	P6.3	-	-	-	-	-	-
16	P6.4	15	P6.4	-	-	-	-
17	P6.5	16	P6.5	-	-	-	-
18	VSSIO	17	VSSIO	10	VSSD	10	VSSD
39	P7.0	37	P7.0	26	P7.0	-	-
40	P7.1	38	P7.1	27	P7.1	-	-

4 Pinouts

68-QFN		64-TQFP		48-TQFP		44-TQFP	
Pin	Name	Pin	Name	Pin	Name	Pin	Name
41	P7.2	-	-	-	-	-	-

The pins of Port 6 are overvoltage-tolerant. Pins 36, 37, and 38 are No-Connects on the 68-pin QFN. Pins 34, 35, and 36 are No-Connects on the 64-pin TQFP. Pins 11 and 15 are No-connects in the 48-pin TQFP. All VSS pins must be tied together.

The output drivers of I/O Ports P0 and P7 are connected to VDDD. Output drivers of I/O Ports 1, 2, and 5 are connected to VDDA. Output drivers of I/O Ports 3, 4, and 6 are connected to VDDIO.

Each of the pins shown in the previous table can have multiple programmable functions as shown in the following table. Column headings refer to Analog and Alternate pin functions:

Port/ Pin	Analog	Alt. Function 1	Alt. Function 2	Alt. Function 3	Alt. Function 4	Alt. Function 5
P0.0	lpcomp.in_p[0]	-	-	-	-	scb[0].spi_select 1:0
P0.1	lpcomp.in_n[0]	-	-	-	-	scb[0].spi_select 2:0
P0.2	lpcomp.in_p[1]	-	-	-	-	scb[0].spi_select 3:0
P0.3	lpcomp.in_n[1]	-	-	-	-	-
P0.4	wco_in	-	scb[1].uart_rx:0	-	scb[1].i2c_scl:0	scb[1].spi_mosi: 1
P0.5	wco_out	-	scb[1].uart_tx:0	-	scb[1].i2c_sda:0	scb[1].spi_miso: 1
P0.6	-	ext_clk:0	scb[1].uart_cts:0	-	-	scb[1].spi_clk:1
P0.7	-	-	scb[1].uart_rts:0	-	wakeup	scb[1].spi_select 0:1
P1.0	ctb0.aa0.inp	tcpwm.line[2]	scb[0].uart_rx:1	-	scb[0].i2c_scl:0	scb[0].spi_mosi: 1
P1.1	ctb0.aa0.inm	tcpwm.line_com pl[2]	scb[0].uart_tx:1	-	scb[0].i2c_sda:0	scb[0].spi_miso: 1
P1.2	ctb0.aa0.out	tcpwm.line[3]	scb[0].uart_cts:1	-	-	scb[0].spi_clk:1
P1.3	ctb0.aa1.out	tcpwm.line_com pl[3]	scb[0].uart_rts:1	-	-	scb[0].spi_select 0:1
P1.4	ctb0.aa1.inm	tcpwm.line[6]	-	-	-	scb[0].spi_select 1:1
P1.5	ctb0.aa1.inp	tcpwm.line_com pl[6]	-	-	-	scb[0].spi_select 2:1
P1.6	ctb0.aa0.inp_a lt	tcpwm.line[7]	-	-	-	scb[0].spi_select 3:1
P1.7	ctb0.aa1.inp_a lt	tcpwm.line_com pl[7]	-	-	-	-

4 Pinouts

Port/ Pin	Analog	Alt. Function 1	Alt. Function 2	Alt. Function 3	Alt. Function 4	Alt. Function 5
P2.0	sarmux.0	tcpwm.line[4]	-	-	scb[1].i2c_scl:1	scb[1].spi_mosi: 2
P2.1	sarmux.1	tcpwm.line_com pl[4]	-	-	scb[1].i2c_sda:1	scb[1].spi_miso: 2
P2.2	sarmux.2	tcpwm.line[5]	-	-	-	scb[1].spi_clk:2
P2.3	sarmux.3	tcpwm.line_com pl[5]	-	-	-	scb[1].spi_select 0:2
P2.4	sarmux.4	tcpwm.line[0]	-	-	-	scb[1].spi_select 1:1
P2.5	sarmux.5	tcpwm.line_com pl[0]	-	-	-	scb[1].spi_select 2:1
P2.6	sarmux.6	tcpwm.line[1]	-	-	-	scb[1].spi_select 3:1
P2.7	sarmux.7	tcpwm.line_com pl[1]	-	-	-	scb[3].spi_select 0:1
P3.0	-	tcpwm.line[0]	scb[1].uart_rx:1	-	scb[1].i2c_scl:2	scb[1].spi_mosi: 0
P3.1	-	tcpwm.line_com pl[0]	scb[1].uart_tx:1	-	scb[1].i2c_sda:2	scb[1].spi_miso: 0
P3.2	-	tcpwm.line[1]	scb[1].uart_cts:1	-	swd_data	scb[1].spi_clk:0
P3.3	-	tcpwm.line_com pl[1]	scb[1].uart_rts:1	-	swd_clk	scb[1].spi_select 0:0
P3.4	-	tcpwm.line[2]	-	-	-	scb[1].spi_select 1:0
P3.5	-	tcpwm.line_com pl[2]	-	-	-	scb[1].spi_select 2:0
P3.6	-	tcpwm.line[3]	-	-	-	scb[1].spi_select 3:0
P3.7	-	tcpwm.line_com pl[3]	-	-	-	-
P4.0	-	-	scb[0].uart_rx:0	-	scb[0].i2c_scl:1	scb[0].spi_mosi: 0
P4.1	-	-	scb[0].uart_tx:0	-	scb[0].i2c_sda:1	scb[0].spi_miso: 0
P4.2	csd[0].c_mod	-	scb[0].uart_cts:0	-	lpcomp.comp[0] :0	scb[0].spi_clk:0
P4.3	csd[0].c_sh_tan k	-	scb[0].uart_rts:0	-	lpcomp.comp[1] :0	scb[0].spi_select 0:0
P4.4	-	-	-	-	-	scb[0].spi_select 1:2

4 Pinouts

Port/ Pin	Analog	Alt. Function 1	Alt. Function 2	Alt. Function 3	Alt. Function 4	Alt. Function 5
P4.5	–	–	–	–	–	scb[0].spi_select 2:2
P4.6	–	–	–	–	–	scb[0].spi_select 3:2
P4.7	–	–	–	–	–	–
P5.0	ctb1.oa0.inp	tcpwm.line[4]	scb[2].uart_rx:0	–	scb[2].i2c_scl:0	scb[2].spi_mosi: 0
P5.1	ctb1.oa0.inm	tcpwm.line_com pl[4]	scb[2].uart_tx:0	–	scb[2].i2c_sda:0	scb[2].spi_miso: 0
P5.2	ctb1.oa0.out	tcpwm.line[5]	scb[2].uart_cts:0	–	lpcomp.comp[0] :1	scb[2].spi_clk:0
P5.3	ctb1.oa1.out	tcpwm.line_com pl[5]	scb[2].uart_rts:0	–	lpcomp.comp[1] :1	scb[2].spi_select 0:0
P5.4	ctb1.oa1.inm	tcpwm.line[6]	–	–	–	scb[2].spi_select 1:0
P5.5	ctb1.oa1.inp	tcpwm.line_com pl[6]	–	–	–	scb[2].spi_select 2:0
P5.6	ctb1.oa0.inp_a lt	tcpwm.line[7]	–	–	–	scb[2].spi_select 3:0
P5.7	ctb1.oa1.inp_a lt	tcpwm.line_com pl[7]	–	–	–	–
P6.0	–	tcpwm.line[4]	scb[3].uart_rx:0	–	scb[3].i2c_scl:0	scb[3].spi_mosi: 0
P6.1	–	tcpwm.line_com pl[4]	scb[3].uart_tx:0	–	scb[3].i2c_sda:0	scb[3].spi_miso: 0
P6.2	–	tcpwm.line[5]	scb[3].uart_cts:0	–	–	scb[3].spi_clk:0
P6.3	–	tcpwm.line_com pl[5]	scb[3].uart_rts:0	–	–	scb[3].spi_select 0:0
P6.4	–	tcpwm.line[6]	–	–	–	scb[3].spi_select 1:0
P6.5	–	tcpwm.line_com pl[6]	–	–	–	scb[3].spi_select 2:0
P7.0	–	tcpwm.line[0]	scb[3].uart_rx:1	–	scb[3].i2c_scl:1	scb[3].spi_mosi: 1
P7.1	–	tcpwm.line_com pl[0]	scb[3].uart_tx:1	–	scb[3].i2c_sda:1	scb[3].spi_miso: 1
P7.2	–	tcpwm.line[1]	scb[3].uart_cts:1	–	–	scb[3].spi_clk:1

Descriptions of the power pin functions are as follows:

VDDD: Power supply for both analog and digital sections (where there is no V_{DDA} pin).

VDDA: Analog V_{DD} pin where package pins allow; shorted to V_{DDD} otherwise.

VDDIO: I/O pin power domain.

VSSA: Analog ground pin where package pins allow; shorted to VSS otherwise

VSS: Ground pin.

VCCD: Regulated Digital supply ($1.8\text{ V} \pm 5\%$).

Port Pins can all be used as LCD Commons, LCD Segment drivers, or CSD sense and shield pins can be connected to AMUXBUS A or B or can all be used as GPIO pins that can be driven by firmware or DSI signals.

5 Power

The supply voltage range is 1.71 to 5.5 V with all functions and circuits operating over that range.

The PSoC™ 4100M family allows two distinct modes of power supply operation: Unregulated External Supply and Regulated External Supply modes.

5.1 Unregulated external supply

In this mode, the PSoC™ 4100M is powered by an External Power Supply that can be anywhere in the range of 1.8 to 5.5 V. This range is also designed for battery-powered operation, for instance, the chip can be powered from a battery system that starts at 3.5V and works down to 1.8 V. In this mode, the internal regulator of the PSoC™ 4100M supplies the internal logic and the VCCD output of the PSoC™ 4100M must be bypassed to ground via an external Capacitor (in the range of 1 to 1.6 μ F; X5R ceramic or better).

The grounds, VSSA and VSS, must be shorted together. Bypass capacitors must be used from VDDD and VDDA to ground, typical practice for systems in this frequency range is to use a capacitor in the 1 μ F range in parallel with a smaller capacitor (0.1 μ F, for example). Note that these are simply rules of thumb and that, for critical applications, the PCB layout, lead inductance, and the Bypass capacitor parasitic should be simulated to design and obtain optimal bypassing.

Power supply	Bypass capacitors
VDDD–VSS and VDDIO–VSS	0.1 μ F ceramic at each pin plus bulk capacitor 1 to 10 μ F
VDDA–VSSA	0.1 μ F ceramic at pin. Additional 1 μ F to 10 μ F bulk capacitor
VCCD–VSS	1 μ F ceramic capacitor at the VCCD pin
VREF–VSSA (optional)	The internal bandgap may be bypassed with a 1 μ F to 10 μ F capacitor for better ADC performance

5.2 Regulated external supply

In this mode, the PSoC™ 4100M is powered by an external power supply that must be within the range of 1.71 to 1.89 V ($1.8 \pm 5\%$); note that this range needs to include power supply ripple. VCCD and VDDD pins are shorted together and bypassed. The internal regulator is disabled in firmware.

6 Electrical specifications

6.1 Absolute maximum ratings

Table 1 Absolute maximum ratings

Spec ID#	Parameter	Description	Min	Typ	Max	Unit	Details / conditions
SID1	V _{DD_ABS}	Analog or digital supply relative to V _{SS} (V _{SSD} = V _{SSA})	-0.5	-	6	V	Absolute maximum
SID2	V _{CCD_ABS}	Direct digital core voltage input relative to V _{SSD}	-0.5	-	1.95	V	Absolute maximum
SID3	V _{GPIO_ABS}	GPIO voltage; V _{DDD} or V _{DDA}	-0.5	-	V _{DD} +0.5	V	Absolute maximum
SID4	I _{GPIO_ABS}	Current per GPIO	-25	-	25	mA	Absolute maximum
SID5	I _{G-PIO_injection}	GPIO injection current per pin	-0.5	-	0.5	mA	Absolute maximum
BID44	ESD_HBM	Electrostatic discharge human body model	2200	-	-	V	-
BID45	ESD_CDM	Electrostatic discharge charged device model	500	-	-	V	-
BID46	LU	Pin current for latch-up	-140	-	140	mA	-

Note: Usage above the absolute maximum conditions listed in Table 1 may cause permanent damage to the device. Exposure to absolute maximum conditions for extended periods of time may affect device reliability. The maximum storage temperature is 150 °C in compliance with JEDEC Standard JESD22-A103, High Temperature Storage Life. When used below absolute maximum conditions but above normal operating conditions, the device may not operate to specification.

6.2 Device level specifications

All specifications are valid for -40°C ≤ TA ≤ 105°C and TJ ≤ 125°C, except where noted. Specifications are valid for 1.71 V to 5.5 V, except where noted.

Table 2 DC specifications

Spec ID#	Parameter	Description	Min	Typ	Max	Unit	Details / conditions
SID53	V _{DD}	Power Supply Input Voltage (V _{DDA} = V _{DDD} = V _{DD})	1.8	-	5.5	V	With regulator enabled
SID255	V _{DDD}	Power Supply Input Voltage unregulated	1.71	1.8	1.89	V	Internally unregulated Supply
SID54	V _{CCD}	Output voltage (for core logic)	-	1.8	-	V	-

(table continues...)

Table 2 (continued) DC specifications

Spec ID#	Parameter	Description	Min	Typ	Max	Unit	Details / conditions
SID55	C _{EFC}	External Regulator voltage bypass	1	1.3	1.6	μF	X5R ceramic or better
SID56	C _{EXC}	Power supply decoupling capacitor	–	1	–	μF	X5R ceramic or better

Active Mode, V_{DD} = 1.71 V to 5.5 V, –40°C to +105°C

SID6	I _{DD1}	Execute from Flash; CPU at 6 MHz	–	2.2	2.8	mA	–
SID7	I _{DD2}	Execute from Flash; CPU at 12 MHz	–	3.7	4.2	mA	–
SID8	I _{DD3}	Execute from Flash; CPU at 24 MHz	–	6.7	7.2	mA	–

Sleep Mode, –40°C to +105°C

SID21	I _{DD16}	I ² C wakeup, WDT, and Comparators on. Regulator Off.	–	1.75	2.1	mA	V _{DD} = 1.71 to 1.89, 6 MHz
SID22	I _{DD17}	I ² C wakeup, WDT, and Comparators on.	–	1.7	2.1	mA	V _{DD} = 1.8 to 5.5, 6 MHz
SID23	I _{DD18}	I ² C wakeup, WDT, and Comparators on. Regulator Off.	–	2.35	2.8	mA	V _{DD} = 1.71 to 1.89, 12 MHz
SID24	I _{DD19}	I ² C wakeup, WDT, and Comparators on.	–	2.25	2.8	mA	V _{DD} = 1.8 to 5.5, 12 MHz

Deep Sleep Mode, –40°C to + 60°C

SID30	I _{DD25}	I ² C wakeup and WDT on. Regulator Off	–	1.55	20	μA	V _{DD} = 1.71 to 1.89
SID31	I _{DD26}	I ² C wakeup and WDT on	–	1.35	15	μA	V _{DD} = 1.8 to 3.6
SID32	I _{DD27}	I ² C wakeup and WDT on	–	1.5	15	μA	V _{DD} = 3.6 to 5.5

Deep Sleep Mode, +85°C

SID33	I _{DD28}	I ² C wakeup and WDT on. Regulator Off	–	–	60	μA	V _{DD} = 1.71 to 1.89
SID34	I _{DD29}	I ² C wakeup and WDT on	–	–	45	μA	V _{DD} = 1.8 to 3.6
SID35	I _{DD30}	I ² C wakeup and WDT on	–	–	30	μA	V _{DD} = 3.6 to 5.5

Deep Sleep Mode, +105°C

SID33Q	I _{DD28Q}	I ² C wakeup and WDT on. Regulator Off	–	–	135	μA	V _{DD} = 1.71 to 1.89
SID34Q	I _{DD29Q}	I ² C wakeup and WDT on	–	–	180	μA	V _{DD} = 1.8 to 3.6
SID35Q	I _{DD30Q}	I ² C wakeup and WDT on	–	–	140	μA	V _{DD} = 3.6 to 5.5

Hibernate Mode, –40°C to + 60°C

SID39	I _{DD34}	Regulator Off	–	150	3000	nA	V _{DD} = 1.71 to 1.89
SID40	I _{DD35}	–	–	150	1000	nA	V _{DD} = 1.8 to 3.6

(table continues...)

Table 2 (continued) DC specifications

Spec ID#	Parameter	Description	Min	Typ	Max	Unit	Details / conditions
SID41	I _{DD36}	–	–	150	1100	nA	V _{DD} = 3.6 to 5.5
Hibernate Mode, +85°C							
SID42	I _{DD37}	Regulator Off	–	–	4500	nA	V _{DD} = 1.71 to 1.89
SID43	I _{DD38}	–	–	–	3500	nA	V _{DD} = 1.8 to 3.6
SID44	I _{DD39}	–	–	–	3500	nA	V _{DD} = 3.6 to 5.5
Hibernate Mode, +105°C							
SID42Q	I _{DD37Q}	Regulator Off	–	–	19.4	µA	V _{DD} = 1.71 to 1.89
SID43Q	I _{DD38Q}	–	–	–	17	µA	V _{DD} = 1.8 to 3.6
SID44Q	I _{DD39Q}	–	–	–	16	µA	V _{DD} = 3.6 to 5.5
Stop Mode, +85°C							
SID304	I _{DD43A}	Stop Mode current; V _{DD} = 3.6 V	–	35	85	nA	T = –40°C to +60°C
SID304A	I _{DD43B}	Stop Mode current; V _{DD} = 3.6 V	–	–	1450	nA	T = +85°C
Stop Mode, +105°C							
SID304Q	I _{DD43AQ}	Stop Mode current; V _{DD} = 3.6 V	–	–	5645	nA	–
XRES current							
SID307	I _{DD_XR}	Supply current while XRES asserted	–	2	5	mA	–

Table 3 AC specifications

Spec ID#	Parameter	Description	Min	Typ	Max	Units	Details / conditions
SID48	F _{CPU}	CPU frequency	DC	–	48	MHz	1.71 ≤ V _{DD} ≤ 5.5
SID49 ¹⁾	T _{SLEEP}	Wakeup from sleep mode	–	0	–	µs	–
SID50 ¹⁾	T _{DEEPSLEEP}	Wakeup from Deep Sleep mode	–	–	25	µs	24 MHz IMO
SID51 ¹⁾	T _{HIBERNATE}	Wakeup from Hibernate mode	–	–	0.7	ms	–
SID51A ¹⁾	T _{STOP}	Wakeup from Stop mode	–	–	2	ms	–
SID52 ¹⁾	T _{RESETWIDTH}	External reset pulse width	1	–	–	µs	–

1) Guaranteed by characterization.

6.2.1 GPIO

Table 4 GPIO DC specifications

Spec ID#	Parameter	Description	Min	Typ	Max	Unit	Details / conditions
SID57	$V_{IH}^{1)}$	Input voltage high threshold	$0.7 \times V_{DDD}$	–	–	V	CMOS Input
SID57A	IIHS	Input current when Pad > V_{DDIO} for OVT inputs	–	–	10	μA	Per I ² C Spec
SID58	V_{IL}	Input voltage low threshold	–	–	$0.3 \times V_{DDD}$	V	CMOS Input
SID241	$V_{IH}^{1)}$	LVTTL input, $V_{DDD} < 2.7$ V	$0.7 \times V_{DDD}$	–	–	V	–
SID242	V_{IL}	LVTTL input, $V_{DDD} < 2.7$ V	–	–	$0.3 \times V_{DDD}$	V	–
SID243	$V_{IH}^{1)}$	LVTTL input, $V_{DDD} \geq 2.7$ V	2.0	–	–	V	–
SID244	V_{IL}	LVTTL input, $V_{DDD} \geq 2.7$ V	–	–	0.8	V	–
SID59	V_{OH}	Output voltage high level	$V_{DDD} - 0.6$	–	–	V	$I_{OH} = 4$ mA, $V_{DDD} \geq 3$ V
SID60	V_{OH}	Output voltage high level	$V_{DDD} - 0.5$	–	–	V	$I_{OH} = 1$ mA at 1.8-V V_{DDD}
SID61	V_{OL}	Output voltage low level	–	–	0.6	V	$I_{OL} = 4$ mA at 1.8-V V_{DDD}
SID62	V_{OL}	Output voltage low level	–	–	0.6	V	$I_{OL} = 8$ mA, $V_{DDD} \geq 3$ V
SID62A	V_{OL}	Output voltage low level	–	–	0.4	V	$I_{OL} = 3$ mA, $V_{DDD} \geq 3$ V
SID63	R_{PULLUP}	Pull-up resistor	3.5	5.6	8.5	kΩ	–
SID64	$R_{PULLDOWN}$	Pull-down resistor	3.5	5.6	8.5	kΩ	–
SID65 ²⁾	I_{IL}	Input leakage current (absolute value)	–	–	2	nA	25 °C, $V_{DDD} = 3.0$ V
SID65A ²⁾	I_{IL_CTBM}	Input leakage current (absolute value) for CTBM pins	–	–	4	nA	–
SID66	C_{IN}	Input capacitance	–	–	7	pF	–
SID67	V_{HYSTTL}	Input hysteresis LVTTL	25	40	–	mV	$V_{DDD} \geq 2.7$ V
SID68	$V_{HYSCMOS}$	Input hysteresis CMOS	$0.05 \times V_{DDD}$	–	–	mV	–
SID69 ²⁾	I_{DIODE}	Current through protection diode to V_{DD}/V_{SS}	–	–	100	μA	–
SID69A ²⁾	I_{TOT_GPIO}	Maximum Total Source or Sink Chip Current	–	–	200	mA	–

1) V_{IH} must not exceed $V_{DDD} + 0.2$ V.

2) Guaranteed by characterization.

Table 5 GPIO AC specifications

(Guaranteed by characterization.)

Spec ID#	Parameter	Description	Min	Typ	Max	Unit	Details / conditions
SID70	T _{RISEF}	Rise time in fast strong mode	2	–	12	ns	3.3 V V _{DDD} , Clod = 25 pF
SID71	T _{FALLF}	Fall time in fast strong mode	2	–	12	ns	3.3 V V _{DDD} , Clod = 25 pF
SID72	T _{RISES}	Rise time in slow strong mode	10	–	60	ns	3.3 V V _{DDD} , Clod = 25 pF
SID73	T _{FALLS}	Fall time in slow strong mode	10	–	60	ns	3.3 V V _{DDD} , Clod = 25 pF
SID74	F _{GPIOUT1}	GPIO Fout; 3.3 V ≤ V _{DDD} ≤ 5.5 V. Fast strong mode.	–	–	33	MHz	90/10%, 25-pF load, 60/40 duty cycle
SID75	F _{GPIOUT2}	GPIO Fout; 1.7 V ≤ V _{DDD} ≤ 3.3 V. Fast strong mode.	–	–	16.7	MHz	90/10%, 25-pF load, 60/40 duty cycle
SID76	F _{GPIOUT3}	GPIO Fout; 3.3 V ≤ V _{DDD} ≤ 5.5 V. Slow strong mode.	–	–	7	MHz	90/10%, 25-pF load, 60/40 duty cycle
SID245	F _{GPIOUT4}	GPIO Fout; 1.7 V ≤ V _{DDD} ≤ 3.3 V. Slow strong mode.	–	–	3.5	MHz	90/10%, 25-pF load, 60/40 duty cycle
SID246	F _{GPIOIN}	GPIO input operating frequency; 1.71 V ≤ V _{DDD} ≤ 5.5 V	–	–	48	MHz	90/10% V _{IO}

Note: Simultaneous switching transitions on many fully-loaded GPIO pins may cause ground perturbations depending on several factors including PCB and decoupling capacitor design. For applications that are very sensitive to ground perturbations, the slower GPIO slew rate setting may be used.

6.2.2 XRES

Table 6 XRES DC specifications

Spec ID#	Parameter	Description	Min	Typ	Max	Unit	Details / conditions
SID77	V _{IH}	Input voltage high threshold	0.7 × V _{DDD}	–	–	V	CMOS Input
SID78	V _{IL}	Input voltage low threshold	–	–	0.3 × V _{DDD}	V	CMOS Input
SID79	R _{PULLUP}	Pull-up resistor	3.5	5.6	8.5	kΩ	–
SID80	C _{IN}	Input capacitance	–	3	–	pF	–
SID81 ¹⁾	V _{HYSXRES}	Input voltage hysteresis	–	100	–	mV	–
SID82 ¹⁾	I _{DIODE}	Current through protection diode to V _{DDD} /V _{SS}	–	–	100	μA	–

1) Guaranteed by characterization.

Table 7 XRES AC specifications

Spec ID#	Parameter	Description	Min	Typ	Max	Unit	Details / conditions
SID83 ¹⁾	T _{RESETWIDTH}	Reset pulse width	1	–	–	µs	–

1) Guaranteed by characterization.

6.3 Analog peripherals

6.3.1 Opamp

Table 8 Opamp specifications

(Guaranteed by characterization.)

Spec ID#	Parameter	Description	Min	Typ	Max	Unit	Details/ conditions
–	I _{DD}	Opamp block current. No load.	–	–	–	–	–
SID269	I _{DD_HI}	Power = high	–	1100	1850	µA	–
SID270	I _{DD_MED}	Power = medium	–	550	950	µA	–
SID271	I _{DD_LOW}	Power = low	–	150	350	µA	–
–	GBW	Load = 20 pF, 0.1 mA. V _{DDA} = 2.7 V	–	–	–	–	–
SID272	GBW_HI	Power = high	6	–	–	MHz	–
SID273	GBW_MED	Power = medium	4	–	–	MHz	–
SID274	GBW_LO	Power = low	–	1	–	MHz	–
–	I _{OUT_MAX}	V _{DDA} ≥ 2.7 V, 500 mV from rail	–	–	–	–	–
SID275	I _{OUT_MAX_HI}	Power = high	10	–	–	mA	–
SID276	I _{OUT_MAX_MID}	Power = medium	10	–	–	mA	–
SID277	I _{OUT_MAX_LO}	Power = low	–	5	–	mA	–
–	I _{OUT}	V _{DDA} = 1.71 V, 500 mV from rail	–	–	–	–	–
SID278	I _{OUT_MAX_HI}	Power = high	4	–	–	mA	–

(table continues...)

Table 8 (continued) Opamp specifications

(Guaranteed by characterization.)

Spec ID#	Parameter	Description	Min	Typ	Max	Unit	Details/ conditions
SID279	I _{OUT_MAX_MID}	Power = medium	4	–	–	mA	–
SID280	I _{OUT_MAX_LO}	Power = low	–	2	–	mA	–
SID281	V _{IN}	Input voltage range	–0.05	–	V _{DDA} – 0.2	V	Charge-pump on, V _{DDA} ≥ 2.7 V
SID282	V _{CM}	Input common mode voltage	–0.05	–	V _{DDA} – 0.2	V	Charge-pump on, V _{DDA} ≥ 2.7 V
–	V _{OUT}	V _{DDA} ≥ 2.7V	–	–	–	–	–
SID283	V _{OUT_1}	Power = high, I _{load} =10 mA	0.5	–	V _{DDA} – 0.5	V	–
SID284	V _{OUT_2}	Power = high, I _{load} =1 mA	0.2	–	V _{DDA} – 0.2	V	–
SID285	V _{OUT_3}	Power = medium, I _{load} =1 mA	0.2	–	V _{DDA} – 0.2	V	–
SID286	V _{OUT_4}	Power = low, I _{load} =0.1mA	0.2	–	V _{DDA} – 0.2	V	–
SID288	V _{OS_TR}	Offset voltage, trimmed	1	±0.5	1	mV	High mode
SID288A	V _{OS_TR}	Offset voltage, trimmed	–	±1	–	mV	Medium mode
SID288B	V _{OS_TR}	Offset voltage, trimmed	–	±2	–	mV	Low mode
SID290	V _{OS_DR_TR}	Offset voltage drift, trimmed	–10	±3	10	µV/°C	High mode. T _A ≤ 85°C
SID290Q	V _{OS_DR_TR}	Offset voltage drift, trimmed	15	±3	15	µV/°C	High mode. T _A ≤ 105°C

(table continues...)

Table 8 (continued) Opamp specifications

(Guaranteed by characterization.)

Spec ID#	Parameter	Description	Min	Typ	Max	Unit	Details/ conditions
SID290A	V _{OS_DR_TR}	Offset voltage drift, trimmed	–	±10	–	μV/°C	Medium mode
SID290B	V _{OS_DR_TR}	Offset voltage drift, trimmed	–	±10	–	μV/°C	Low mode
SID291	CMRR	DC Common mode rejection ratio. High-power mode. Common Model voltage range from 0.5 V to V _{DDA} - 0.5 V.	60	70	–	dB	V _{DD} = 3.6 V
SID292	PSRR	At 1 kHz, 100-mV ripple	70	85	–	dB	V _{DD} = 3.6 V
–	Noise	–	–	–	–	–	–
SID293	V _{N1}	Input referred, 1 Hz - 1 GHz, power = high	–	94	–	μVrms	–
SID294	V _{N2}	Input referred, 1 kHz, power = high	–	72	–	nV/rtHz	–
SID295	V _{N3}	Input referred, 10 kHz, power = high	–	28	–	nV/rtHz	–
SID296	V _{N4}	Input referred, 100 kHz, power = high	–	15	–	nV/rtHz	–

(table continues...)

Table 8 (continued) Opamp specifications

(Guaranteed by characterization.)

Spec ID#	Parameter	Description	Min	Typ	Max	Unit	Details/ conditions
SID297	Cload	Stable up to maximum load. Performance specs at 50 pF.	–	–	125	pF	–
SID298	Slew_rate	Cload = 50 pF, Power = High, $V_{DDA} \geq 2.7 V$	6	–	–	V/ μ s	–
SID299	T_op_wake	From disable to enable, no external RC dominating	–	25	–	μ s	–
SID299A	OL_GAIN	Open Loop Gain	–	90	–	dB	–
–	Comp_mode	Comparator mode; 50 mV drive, Trise = Tfall (approx.)	–	–	–	–	–
SID300	T _{PD1}	Response time; power = high	–	150	–	ns	–
SID301	T _{PD2}	Response time; power = medium	–	400	–	ns	–
SID302	T _{PD3}	Response time; power = low	–	2000	–	ns	–
SID303	Vhyst_op	Hysteresis	–	10	–	mV	–
Deep Sleep Mode		Mode 2 is lowest current range. Mode 1 has higher GBW.	–	–	–	–	Deep Sleep mode. $V_{DDA} \geq 2.7 V$
SID_DS_1	IDD_HI_M1	Mode 1, High current	–	1400	–	μ A	25°C

(table continues...)

Table 8 (continued) Opamp specifications

(Guaranteed by characterization.)

Spec ID#	Parameter	Description	Min	Typ	Max	Unit	Details/ conditions
SID_DS_2	IDD_MED_M1	Mode 1, Medium current	–	700	–	uA	25°C
SID_DS_3	IDD_LOW_M1	Mode 1, Low current	–	200	–	uA	25°C
SID_DS_4	IDD_HI_M2	Mode 2, High current	–	120	–	uA	25°C
SID_DS_5	IDD_MED_M2	Mode 2, Medium current	–	60	–	uA	25°C
SID_DS_6	IDD_LOW_M2	Mode 2, Low current	–	15	–	uA	25°C
SID_DS_7	GBW_HI_M1	Mode 1, High current	–	4	–	MHz	25°C
SID_DS_8	GBW_MED_M1	Mode 1, Medium current	–	2	–	MHz	25°C
SID_DS_9	GBW_LOW_M1	Mode 1, Low current	–	0.5	–	MHz	25°C
SID_DS_10	GBW_HI_M2	Mode 2, High current	–	0.5	–	MHz	20-pF load, no DC load 0.2 V to $V_{DDA}-1.5$ V
SID_DS_11	GBW_MED_M2	Mode 2, Medium current	–	0.2	–	MHz	20-pF load, no DC load 0.2 V to $V_{DDA}-1.5$ V
SID_DS_12	GBW_LOW_M2	Mode 2, Low current	–	0.1	–	MHz	20-pF load, no DC load 0.2 V to $V_{DDA}-1.5$ V
SID_DS_13	VOS_HI_M1	Mode 1, High current	–	5	–	mV	With trim 25 °C, 0.2 V to $V_{DDA}-1.5$ V
SID_DS_14	VOS_MED_M1	Mode 1, Medium current	–	5	–	mV	With trim 25 °C, 0.2 V to $V_{DDA}-1.5$ V
SID_DS_15	VOS_LOW_M1	Mode 1, Low current	–	5	–	mV	With trim 25 °C, 0.2 V to $V_{DDA}-1.5$ V

(table continues...)

Table 8 (continued) Opamp specifications

(Guaranteed by characterization.)

Spec ID#	Parameter	Description	Min	Typ	Max	Unit	Details/ conditions
SID_DS_16	VOS_HI_M2	Mode 2, High current	–	5	–	mV	With trim 25 °C, 0.2 V to $V_{DDA}-1.5 V$
SID_DS_17	VOS_MED_M2	Mode 2, Medium current	–	5	–	mV	With trim 25 °C, 0.2 V to $V_{DDA}-1.5 V$
SID_DS_18	VOS_LOW_M2	Mode 2, Low current	–	5	–	mV	With trim 25 °C, 0.2 V to $V_{DDA}-1.5 V$
SID_DS_19	IOUT_HI_M1	Mode 1, High current	–	10	–	mA	Output is 0.5 V to $V_{DDA}-0.5 V$
SID_DS_20	IOUT_MED_M1	Mode 1, Medium current	–	10	–	mA	Output is 0.5 V to $V_{DDA}-0.5 V$
SID_DS_21	IOUT_LOW_M1	Mode 1, Low current	–	4	–	mA	Output is 0.5 V to $V_{DDA}-0.5 V$
SID_DS_22	IOUT_HI_M2	Mode 2, High current	–	1	–	mA	Output is 0.5 V to $V_{DDA}-0.5 V$
SID_DS_23	IOUT_MED_M2	Mode 2, Medium current	–	1	–	mA	Output is 0.5 V to $V_{DDA}-0.5 V$
SID_DS_24	IOUT_LOW_M2	Mode 2, Low current	–	0.5	–	mA	Output is 0.5 V to $V_{DDA}-0.5 V$

6.3.2 Comparator

Table 9 Comparator DC specifications

Spec ID#	Parameter	Description	Min	Typ	Max	Unit	Details / conditions
SID85	$V_{OFFSET2}$	Input offset voltage, Common Mode voltage range from 0 to $V_{DD}-1$	–	–	± 4	mV	–
SID85A	$V_{OFFSET3}$	Input offset voltage. Ultra low-power mode ($V_{DDD} \geq 2.2 V$ for Temp $< 0^\circ C$, $V_{DDD} \geq 1.8 V$ for Temp $> 0^\circ C$)	–	± 12	–	mV	–

(table continues...)

Table 9 (continued) Comparator DC specifications

Spec ID#	Parameter	Description	Min	Typ	Max	Unit	Details / conditions
SID86 ¹⁾	V _{HYST}	Hysteresis when enabled, Common Mode voltage range from 0 to V _{DD} -1	–	10	35	mV	–
SID87	V _{ICM1}	Input common mode voltage in normal mode	0	–	V _{DDD} – 0.1	V	Modes 1 and 2
SID247	V _{ICM2}	Input common mode voltage in low power mode (V _{DDD} ≥ 2.2 V for Temp < 0°C, V _{DDD} ≥ 1.8 V for Temp > 0°C)	0	–	V _{DDD}	V	–
SID247A	V _{ICM3}	Input common mode voltage in ultra low power mode	0	–	V _{DDD} – 1.15	V	–
SID88 ¹⁾	CMRR	Common mode rejection ratio	50	–	–	dB	V _{DDD} ≥ 2.7 V
SID88A ¹⁾	CMRR	Common mode rejection ratio	42	–	–	dB	V _{DDD} < 2.7 V
SID89 ¹⁾	I _{CMP1}	Block current, normal mode	–	–	400	µA	–
SID248 ¹⁾	I _{CMP2}	Block current, low power mode	–	–	100	µA	–
SID259 ¹⁾	I _{CMP3}	Block current, ultra low power mode (V _{DDD} ≥ 2.2 V for Temp < 0°C, V _{DDD} ≥ 1.8 V for Temp > 0°C)	–	6	28	µA	–
SID90 ¹⁾	Z _{CMP}	DC input impedance of comparator	35	–	–	MΩ	–

1) Guaranteed by characterization.

Table 10 Comparator AC specifications

(Guaranteed by characterization.)

Spec ID#	Parameter	Description	Min	Typ	Max	Unit	Details / conditions
SID91	T _{RESP1}	Response time, normal mode	–	–	110	ns	50-mV overdrive
SID258	T _{RESP2}	Response time, low power mode	–	–	200	ns	50-mV overdrive
SID92	T _{RESP3}	Response time, ultra low power mode (V _{DDD} ≥ 2.2 V for Temp < 0°C, V _{DDD} ≥ 1.8 V for Temp > 0°C)	–	–	15	µs	200-mV overdrive

6.3.3 Temperature sensor

Table 11 Temperature sensor specifications

Spec ID#	Parameter	Description	Min	Typ	Max	Unit	Details / conditions
SID93	T _{SENSACC}	Temperature sensor accuracy	–5	±1	+5	°C	–40 to +85°C

6.3.4 SAR ADC

Table 12 SAR ADC DC specifications

Spec ID#	Parameter	Description	Min	Typ	Max	Unit	Details/ conditions
SID94	A_RES	Resolution	-	-	12	bits	-
SID95	A_CHNIS_S	Number of channels - single ended	-	-	16	-	8 full speed
SID96	A-CHNKS_D	Number of channels - differential	-	-	8	-	Diff inputs use neighboring I/O
SID97 ¹⁾	A-MONO	Monotonicity	Yes			-	-
SID98	A_GAINERR	Gain error	-	-	±0.1	%	With external reference
SID99	A_OFFSET	Input offset voltage	-	-	2	mV	Measured with 1-V V _{REF}
SID100	A_ISAR	Current consumption	-	-	1	mA	-
SID101 ¹⁾	A_VINS	Input voltage range - single ended	V _{SS}	-	V _{DDA}	V	-
SID102 ¹⁾	A_VIND	Input voltage range - differential	V _{SS}	-	V _{DDA}	V	-
SID103 ¹⁾	A_INRES	Input resistance	-	-	2.2	KΩ	-
SID104 ¹⁾	A_INCAP	Input capacitance	-	-	10	pF	-

1) Guaranteed by characterization.

Table 13 SAR ADC AC specifications

(Guaranteed by characterization.)

Spec ID#	Parameter	Description	Min	Typ	Max	Unit	Details/ conditions
SID106	A_PSRR	Power supply rejection ratio	70	-	-	dB	-
SID107	A_CMRR	Common mode rejection ratio	66	-	-	dB	Measured at 1 V
SID108	A_SAMP_1	Sample rate with external reference bypass cap	-	-	1	Msp/s	-
SID108A	A_SAMP_2	Sample rate with no bypass cap. Reference = V _{DD}	-	-	1	Msp/s	-
SID108B	A_SAMP_3	Sample rate with no bypass cap. Internal reference	-	-	100	Ksp/s	-
SID109	A_SNR	Signal-to-noise and distortion ratio (SINAD)	66	-	-	dB	F _{IN} = 10 kHz
SID111	A_INL	Integral non linearity	-1.4	-	+1.4	LSB	V _{DD} = 1.71 to 5.5, 1 Msp/s, V _{ref} = 1 to 5.5

(table continues...)

Table 13 (continued) SAR ADC AC specifications

(Guaranteed by characterization.)

Spec ID#	Parameter	Description	Min	Typ	Max	Unit	Details/ conditions
SID111A	A_INL	Integral non linearity	-1.4	-	+1.4	LSB	$V_{DD} = 1.71$ to 3.6, 1 Msps, $V_{ref} = 1.71$ to V_{DD}
SID111B	A_INL	Integral non linearity	-1.4	-	+1.4	LSB	$V_{DD} = 1.71$ to 5.5, 500 ksps, $V_{ref} = 1$ to 5.5
SID112	A_DNL	Differential non linearity	-0.9	-	+1.35	LSB	$V_{DD} = 1.71$ to 5.5, 1 Msps, $V_{ref} = 1$ to 5.5
SID112A	A_DNL	Differential non linearity	-0.9	-	+1.35	LSB	$V_{DD} = 1.71$ to 3.6, 1 Msps, $V_{ref} = 1.71$ to V_{DD}
SID112B	A_DNL	Differential non linearity	-0.9	-	+1.35	LSB	$V_{DD} = 1.71$ to 5.5, 500 ksps, $V_{ref} = 1$ to 5.5
SID113	A_THD	Total harmonic distortion	-	-	-65	dB	$F_{IN} = 10$ kHz

6.3.5 CSD

Table 14 CSD block specification

Spec ID#	Parameter	Description	Min	Typ	Max	Unit	Details/ conditions
CSD specification							
SID308	VCSD	Voltage range of operation	1.71	-	5.5	V	-
SID309	IDAC1	DNL for 8-bit resolution	-1	-	1	LSB	-
SID310	IDAC1	INL for 8-bit resolution	-3	-	3	LSB	-
SID311	IDAC2	DNL for 7-bit resolution	-1	-	1	LSB	-
SID312	IDAC2	INL for 7-bit resolution	-3	-	3	LSB	-
SID313 ¹⁾	SNR	Ratio of counts of finger to noise	5	-	-	Ratio	Capacitance range of 9 to 35 pF, 0.1 pF sensitivity
SID314	IDAC1_CRT1	Output current of Idac1 (8-bits) in High range	-	612	-	μA	-
SID314A	IDAC1_CRT2	Output current of Idac1(8-bits) in Low range	-	306	-	μA	-
SID315	IDAC2_CRT1	Output current of Idac2 (7-bits) in High range	-	304.8	-	μA	-

(table continues...)

Table 14 (continued) CSD block specification

Spec ID#	Parameter	Description	Min	Typ	Max	Unit	Details/ conditions
SID315A	IDAC2_CRT2	Output current of Idac2 (7-bits) in Low range	–	152.4	–	µA	–

1) Guaranteed by characterization.

6.4 Digital peripherals

The following specifications apply to the Timer/Counter/PWM peripheral in timer mode.

6.4.1 Timer/Counter/PWM

Table 15 TCPWM specifications

(Guaranteed by characterization.)

Spec ID	Parameter	Description	Min	Typ	Max	Unit	Details / conditions
SID.TCPWM.1	ITCPWM1	Block current consumption at 3 MHz	–	–	45	µA	All modes (Timer/Counter/PWM)
SID.TCPWM.2	ITCPWM2	Block current consumption at 12 MHz	–	–	155	µA	All modes (Timer/Counter/PWM)
SID.TCPWM.2A	ITCPWM3	Block current consumption at 48 MHz	–	–	650	µA	All modes (Timer/Counter/PWM)
SID.TCPWM.3	TCPWMFREQ	Operating frequency	–	–	Fc	MHz	Fc max = Fcpu. Maximum = 24 MHz
SID.TCPWM.4	TPWMENEXT	Input Trigger Pulse Width for all Trigger Events	2/Fc	–	–	ns	Trigger Events can be Stop, Start, Reload, Count, Capture, or Kill depending on which mode of operation is selected.
SID.TCPWM.5	TPWMEXT	Output Trigger Pulse widths	2/Fc	–	–	ns	Minimum possible width of Overflow, Underflow, and CC (Counter equals Compare value) trigger outputs
SID.TCPWM.5A	TCRES	Resolution of Counter	1/Fc	–	–	ns	Minimum time between successive counts

(table continues...)

Table 15 (continued) TCPWM specifications

(Guaranteed by characterization.)

Spec ID	Parameter	Description	Min	Typ	Max	Unit	Details / conditions
SID.TCPWM.5B	PWMRES	PWM Resolution	1/Fc	–	–	ns	Minimum pulse width of PWM Output
SID.TCPWM.5C	QRES	Quadrature inputs resolution	1/Fc	–	–	ns	Minimum pulse width between Quadrature phase inputs.

6.4.2 I2C

Table 16 Fixed I²C DC specifications

(Guaranteed by characterization.)

Spec ID#	Parameter	Description	Min	Typ	Max	Unit	Details/ conditions
SID149	I _{I2C1}	Block current consumption at 100 kHz	–	–	50	μA	–
SID150	I _{I2C2}	Block current consumption at 400 kHz	–	–	135	μA	–
SID151	I _{I2C3}	Block current consumption at 1 Mbps	–	–	310	μA	–
SID152	I _{I2C4}	I ² C enabled in Deep Sleep mode	–	–	1.4	μA	–

Table 17 Fixed I²C AC specifications

(Guaranteed by characterization.)

Spec ID#	Parameter	Description	Min	Typ	Max	Unit	Details/ conditions
SID153	F _{I2C1}	Bit rate	–	–	1	Mbps	–

6.4.3 LCD direct drive

Table 18 LCD direct drive DC specifications

(Guaranteed by characterization.)

Spec ID	Parameter	Description	Min	Typ	Max	Unit	Details / conditions
SID154	I _{LCDLOW}	Operating current in low power mode	–	5	–	µA	16 × 4 small segment disp. at 50 Hz
SID155 ¹⁾	C _{LDCAP}	LCD capacitance per segment/ common driver	–	500	5000	pF	–
SID156	LCD _{OFFSET}	Long-term segment offset	–	20	–	mV	–
SID157	I _{LCDOP1}	PWM Mode current. 5-V bias. 24-MHz IMO	–	0.6	–	mA	32 × 4 segments. 50 Hz, 25 °C
SID158	I _{LCDOP2}	PWM Mode current. 3.3-V bias. 24-MHz IMO.	–	0.5	–	mA	32 × 4 segments. 50 Hz, 25 °C

1) Guaranteed by design.

Table 19 LCD direct drive AC specifications

(Guaranteed by characterization.)

Spec ID	Parameter	Description	Min	Typ	Max	Unit	Details / conditions
SID159	F _{LCD}	LCD frame rate	10	50	150	Hz	–

Table 20 Fixed UART DC specifications

(Guaranteed by characterization.)

Spec ID	Parameter	Description	Min	Typ	Max	Unit	Details / conditions
SID160	I _{UART1}	Block current consumption at 100 Kbits/sec	–	–	55	µA	–
SID161	I _{UART2}	Block current consumption at 1000 Kbits/sec	–	–	312	µA	–

Table 21 Fixed UART AC specifications

(Guaranteed by characterization.)

Spec ID	Parameter	Description	Min	Typ	Max	Unit	Details / conditions
SID162	F _{UART}	Bit rate	–	–	1	Mbps	–

6.4.4 SPI specifications

Table 22 Fixed SPI DC specifications

(Guaranteed by characterization.)

Spec ID	Parameter	Description	Min	Typ	Max	Unit	Details / conditions
SID163	I _{SPI1}	Block current consumption at 1 Mbits/sec	–	–	360	μA	–
SID164	I _{SPI2}	Block current consumption at 4 Mbits/sec	–	–	560	μA	–
SID165	I _{SPI3}	Block current consumption at 8 Mbits/sec	–	–	600	μA	–

Table 23 Fixed SPI AC specifications

(Guaranteed by characterization.)

Spec ID	Parameter	Description	Min	Typ	Max	Unit	Details / conditions
SID166	F _{SPI}	SPI operating frequency (master; 6X oversampling)	–	–	8	MHz	–

Table 24 Fixed SPI Master mode AC specifications

(Guaranteed by characterization.)

Spec ID	Parameter	Description	Min	Typ	Max	Unit	Details / conditions
SID167	T _{DMO}	MOSI valid after Sclock driving edge	–	–	15	ns	–
SID168	T _{DSI}	MISO valid before Sclock capturing edge. Full clock, late MISO Sampling used	20	–	–	ns	–
SID169	T _{HMO}	Previous MOSI data hold time with respect to capturing edge at Slave	0	–	–	ns	–

Table 25 Fixed SPI Slave mode AC specifications

(Guaranteed by characterization.)

Spec ID	Parameter	Description	Min	Typ	Max	Unit	Details / conditions
SID170	T _{DMI}	MOSI valid before Sclock capturing edge	40	–	–	ns	–
SID171	T _{DSO}	MISO valid after Sclock driving edge	–	–	42 + 3 × (1/FCPU)	ns	–
SID171A	T _{DSO_ext}	MISO valid after Sclock driving edge in Ext. Clock mode	–	–	48	ns	–
SID172	T _{HSO}	Previous MISO data hold time	0	–	–	ns	–
SID172A	T _{SSELSCK}	SSEL Valid to first SCK Valid edge	100	–	–	ns	–

6.5 Memory

Table 26 Flash DC specifications

(Guaranteed by characterization.)

Spec ID	Parameter	Description	Min	Typ	Max	Unit	Details / conditions
SID173	V _{PE}	Erase and program voltage	1.71	–	5.5	V	–

Table 27 Flash AC specifications

(Guaranteed by characterization.)

Spec ID	Parameter	Description	Min	Typ	Max	Unit	Details / conditions
SID174	T _{ROWWRITE}	Row (block) write time (erase and program)	–	–	20	ms	Row (block) = 128 bytes
SID175	T _{ROWERASE}	Row erase time	–	–	13	ms	–
SID176	T _{ROWPROGRAM}	Row program time after erase	–	–	7	ms	–
SID178	T _{BULKERASE}	Bulk erase time (128 KB)	–	–	35	ms	–
SID179	T _{SECTORERASE}	Sector erase time (8 KB)	–	–	15	ms	–
SID180 ¹⁾	T _{DEVPROG}	Total device program time	–	–	15	seconds	–
SID181 ¹⁾	F _{END}	Flash endurance	100 K	–	–	cycles	–
SID182 ¹⁾	F _{RET}	Flash retention. T _A ≤ 55 °C, 100 K P/E cycles	20	–	–	years	–
SID182A ¹⁾		Flash retention. T _A ≤ 85 °C, 10 K P/E cycles	10	–	–	years	–
SID182B ¹⁾	F _{RETQ}	Flash retention. T _A ≤ 105 °C, 10 K P/E cycles, ≤ three years at T _A ≥ 85 °C	10	20	–	years	–

1) Guaranteed by characterization.

6.6 System resources

6.6.1 Power-on reset (POR) with Brown Out

Table 28 Imprecise Power-on reset (PRES)

Spec ID	Parameter	Description	Min	Typ	Max	Unit	Details/conditions
SID185 ¹⁾	V _{RISEIPOR}	Rising trip voltage	0.80	–	1.45	V	–
SID186 ¹⁾	V _{FALLIPOR}	Falling trip voltage	0.75	–	1.4	V	–
SID187 ¹⁾	V _{IPORHYST}	Hysteresis	15	–	200	mV	–

1) Guaranteed by characterization.

Table 29 Precise Power-on reset (POR)

Spec ID	Parameter	Description	Min	Typ	Max	Unit	Details/conditions
SID190 ¹⁾	V _{FALLPPOR}	BOD trip voltage in active and sleep modes	1.64	–	–	V	–
SID192 ¹⁾	V _{FALLDPSLP}	BOD trip voltage in Deep Sleep	1.4	–	–	V	–

1) Guaranteed by characterization.

6.6.2 Voltage monitors

Table 30 Voltage monitors DC specifications

Spec ID	Parameter	Description	Min	Typ	Max	Unit	Details/conditions
SID195	V _{LVI1}	LVI_A/D_SEL[3:0] = 0000b	1.71	1.75	1.79	V	–
SID196	V _{LVI2}	LVI_A/D_SEL[3:0] = 0001b	1.76	1.80	1.85	V	–
SID197	V _{LVI3}	LVI_A/D_SEL[3:0] = 0010b	1.85	1.90	1.95	V	–
SID198	V _{LVI4}	LVI_A/D_SEL[3:0] = 0011b	1.95	2.00	2.05	V	–
SID199	V _{LVI5}	LVI_A/D_SEL[3:0] = 0100b	2.05	2.10	2.15	V	–
SID200	V _{LVI6}	LVI_A/D_SEL[3:0] = 0101b	2.15	2.20	2.26	V	–
SID201	V _{LVI7}	LVI_A/D_SEL[3:0] = 0110b	2.24	2.30	2.36	V	–
SID202	V _{LVI8}	LVI_A/D_SEL[3:0] = 0111b	2.34	2.40	2.46	V	–
SID203	V _{LVI9}	LVI_A/D_SEL[3:0] = 1000b	2.44	2.50	2.56	V	–
SID204	V _{LVI10}	LVI_A/D_SEL[3:0] = 1001b	2.54	2.60	2.67	V	–
SID205	V _{LVI11}	LVI_A/D_SEL[3:0] = 1010b	2.63	2.70	2.77	V	–
SID206	V _{LVI12}	LVI_A/D_SEL[3:0] = 1011b	2.73	2.80	2.87	V	–
SID207	V _{LVI13}	LVI_A/D_SEL[3:0] = 1100b	2.83	2.90	2.97	V	–
SID208	V _{LVI14}	LVI_A/D_SEL[3:0] = 1101b	2.93	3.00	3.08	V	–
SID209	V _{LVI15}	LVI_A/D_SEL[3:0] = 1110b	3.12	3.20	3.28	V	–
SID210	V _{LVI16}	LVI_A/D_SEL[3:0] = 1111b	4.39	4.50	4.61	V	–
SID211 ¹⁾	LVI_IDD	Block current	–	–	100	µA	–

1) Guaranteed by characterization.

Table 31 Voltage monitors AC specifications

Spec ID	Parameter	Description	Min	Typ	Max	Unit	Details/conditions
SID212 ¹⁾	T _{MONTRIP}	Voltage monitor trip time	–	–	1	µs	–

1) Guaranteed by characterization.

6.6.3 SWD interface

Table 32 SWD interface specifications

Spec ID	Parameter	Description	Min	Typ	Max	Unit	Details/ conditions
SID213	F_SWCLK1	$3.3\text{ V} \leq V_{DD} \leq 5.5\text{ V}$	–	–	14	MHz	SWCLK \leq 1/3 CPU clock frequency
SID214	F_SWCLK2	$1.71\text{ V} \leq V_{DD} \leq 3.3\text{ V}$	–	–	7	MHz	SWCLK \leq 1/3 CPU clock frequency
SID215 ¹⁾	T_SWDI_SETUP	$T = 1/f\text{ SWCLK}$	$0.25 \cdot T$	–	–	ns	–
SID216 ¹⁾	T_SWDI_HOLD	$T = 1/f\text{ SWCLK}$	$0.25 \cdot T$	–	–	ns	–
SID217 ¹⁾	T_SWDO_VALID	$T = 1/f\text{ SWCLK}$	–	–	$0.5 \cdot T$	ns	–
SID217A ¹⁾	T_SWDO_HOLD	$T = 1/f\text{ SWCLK}$	1	–	–	ns	–

1) Guaranteed by characterization.

6.6.4 Internal main oscillator

Table 33 IMO DC specifications

(Guaranteed by design.)

Spec ID	Parameter	Description	Min	Typ	Max	Unit	Details / conditions
SID218	I _{IMO1}	IMO operating current at 48 MHz	–	–	1000	μA	–
SID219	I _{IMO2}	IMO operating current at 24 MHz	–	–	325	μA	–
SID220	I _{IMO3}	IMO operating current at 12 MHz	–	–	225	μA	–
SID221	I _{IMO4}	IMO operating current at 6 MHz	–	–	180	μA	–
SID222	I _{IMO5}	IMO operating current at 3 MHz	–	–	150	μA	–

Table 34 IMO AC specifications

Spec ID	Parameter	Description	Min	Typ	Max	Unit	Details / conditions
SID223	F _{IMOTOL1}	Frequency variation from 3 to 48 MHz	–	–	±2	%	±3% if T _A > 85 °C and IMO frequency < 24 MHz
SID226	T _{STARTIMO}	IMO startup time	–	–	12	μs	–
SID227	T _{JITRMSIMO1}	RMS Jitter at 3 MHz	–	156	–	ps	–

(table continues...)

Table 34 (continued) IMO AC specifications

Spec ID	Parameter	Description	Min	Typ	Max	Unit	Details / conditions
SID228	T _{JITRMSIM02}	RMS Jitter at 24 MHz	–	145	–	ps	–
SID229	T _{JITRMSIM03}	RMS Jitter at 48 MHz	–	139	–	ps	–

6.6.5 Internal low-speed oscillator

Table 35 ILO DC specifications

(Guaranteed by design.)

Spec ID#	Parameter	Description	Min	Typ	Max	Unit	Details/ conditions
SID231 ¹⁾	I _{ILO1}	ILO operating current at 32 kHz	–	0.3	1.05	μA	–
SID233 ²⁾	I _{ILOLEAK}	ILO leakage current	–	2	15	nA	–

1) Guaranteed by characterization

2) Guaranteed by design.

Table 36 ILO AC specifications

Spec ID#	Parameter	Description	Min	Typ	Max	Unit	Details/conditions
SID234 ¹⁾	T _{STARTILO1}	ILO startup time	–	–	2	ms	–
SID236 ¹⁾	T _{ILODUTY}	ILO duty cycle	40	50	60	%	–
SID237	F _{ILOTRIM1}	32 kHz trimmed frequency	15	32	50	kHz	Max ILO frequency is 70 kHz if T _A > 85 °C

1) Guaranteed by characterization.

Table 37 External clock specifications

Spec ID#	Parameter	Description	Min	Typ	Max	Unit	Details / conditions
SID305 ¹⁾	ExtClkFreq	External Clock input Frequency	0	–	48	MHz	–
SID306 ¹⁾	ExtClkDuty	Duty cycle; Measured at V _{DD/2}	45	–	55	%	–

1) Guaranteed by characterization.

Table 38 Watch crystal oscillator (WCO) specifications

Spec ID#	Parameter	Description	Min	Typ	Max	Unit	Details / conditions
----------	-----------	-------------	-----	-----	-----	------	----------------------

IMO WCO-PLL calibrated mode

SID330	IMO _{WCO1}	Frequency variation with IMO set to 3 MHz	–0.6	–	0.6	%	Does not include WCO tolerance
--------	---------------------	---	------	---	-----	---	--------------------------------

(table continues...)

Table 38 (continued) Watch crystal oscillator (WCO) specifications

Spec ID#	Parameter	Description	Min	Typ	Max	Unit	Details / conditions
SID331	IMO _{WCO2}	Frequency variation with IMO set to 5 MHz	-0.4	-	0.4	%	Does not include WCO tolerance
SID332	IMO _{WCO3}	Frequency variation with IMO set to 7 MHz or 9 MHz	-0.3	-	0.3	%	Does not include WCO tolerance
SID333	IMO _{WCO4}	All other IMO frequency settings	-0.2	-	0.2	%	Does not include WCO tolerance

WCO specifications

SID398	F _{WCO}	Crystal frequency	-	32.768	-	kHz	-
SID399	F _{TOL}	Frequency tolerance	-	50	250	ppm	With 20-ppm crystal
SID400	ESR	Equivalent series resistance	-	50	-	kΩ	-
SID401	PD	Drive level	-	-	1	μW	-
SID402	T _{START}	Startup time	-	-	500	ms	-
SID403	C _L	Crystal load capacitance	6	-	12.5	pF	-
SID404	C ₀	Crystal shunt capacitance	-	1.35	-	pF	-
SID405	I _{WCO1}	Operating current (high power mode)	-	-	8	uA	-

Table 39 Block specs

Spec ID#	Parameter	Description	Min	Typ	Max	Unit	Details / conditions
SID256*	T _{WS48} *	Number of wait states at 48 MHz	2	-	-	-	CPU execution from Flash
SID257	T _{WS24} *	Number of wait states at 24 MHz	1	-	-	-	CPU execution from Flash
SID260 ¹⁾	V _{REFSAR}	Trimmed internal reference to SAR	-1	-	+1	%	Percentage of Vbg (1.024 V)
SID261 ¹⁾	F _{SARINTREF}	SAR operating speed without external reference bypass	-	-	100	ksps	12-bit resolution
SID262 ²⁾	T _{CLKSWITCH}	Clock switching from clk1 to clk2 in clk1 periods	3	-	4	Periods	-

* Tws48 and Tws24 are guaranteed by Design.

1) Guaranteed by characterization.

2) Guaranteed by design.

7 Ordering information

The PSoC™ 4100M family part numbers and features are listed in the following table.

Category	Product	Features													Package				
		Max CPU Speed (MHz)	Flash (KB)	SRAM (KB)	Opamp (CTBm)	CSD	IDAC (1x7-Bit, 1-8-Bit)	Direct LCD Drive	12-bit SAR ADC	LP Comparators	TCPWM Blocks	SCB Blocks	CAN	GPIO	44-TQFP	48-TQFP	64-TQFP (0.5-mm pitch)	64-TQFP (0.8-mm pitch)	68-QFN
4125	CY8C4125AZI-M433	24	32	4	2	-	-	-	806 ksp/s	2	8	3	-	38	-	✓	-	-	-
	CY8C4125AZI-M443	24	32	4	2	✓	-	✓	806 ksp/s	2	8	3	-	38	-	✓	-	-	-
	CY8C4125AZI-M445	24	32	4	2	✓	-	✓	806 ksp/s	2	8	4	-	51	-	-	✓	-	-
	CY8C4125LTI-M445	24	32	4	2	✓	-	✓	806 ksp/s	2	8	4	-	55	-	-	-	-	✓
	CY8C4125AXI-M445	24	32	4	2	✓	-	✓	806 ksp/s	2	8	4	-	51	-	-	-	✓	-
4126	CY8C4126AZI-M443	24	64	8	2	✓	-	✓	806 ksp/s	2	8	3	-	38	-	✓	-	-	-
	CY8C4126AXI-M443	24	64	8	2	✓	-	✓	806 ksp/s	2	8	2	-	36	✓	-	-	-	-
	CY8C4126AZI-M445	24	64	8	2	✓	-	✓	806 ksp/s	2	8	4	-	51	-	-	✓	-	-
	CY8C4126AZI-M475	24	64	8	4	-	✓	-	806 ksp/s	2	8	4	-	51	-	-	✓	-	-
	CY8C4126LTI-M445	24	64	8	2	✓	-	✓	806 ksp/s	2	8	4	-	55	-	-	-	-	✓
	CY8C4126LTI-M475	24	64	8	4	-	✓	-	806 ksp/s	2	8	4	-	55	-	-	-	-	✓
	CY8C4126AXI-M445	24	64	8	2	✓	-	✓	806 ksp/s	2	8	4	-	51	-	-	-	✓	-
4127	CY8C4127LTI-M475	24	128	16	4	✓	✓	-	806 ksp/s	2	8	4	-	55	-	-	-	-	✓
	CY8C4127AZI-M475	24	128	16	4	-	✓	-	806 ksp/s	2	8	4	-	51	-	-	✓	-	-
	CY8C4127AZI-M485	24	128	16	4	✓	✓	✓	806 ksp/s	2	8	4	-	51	-	-	✓	-	-
	CY8C4127AXI-M485	24	128	16	4	✓	✓	✓	806 ksp/s	2	8	4	-	51	-	-	-	✓	-

The nomenclature used in the preceding table is based on the following part numbering convention:

Field	Description	Values	Meaning
CY8C	Infineon prefix		
4	Architecture	4	PSoC™ 4
A	Family	1	4100 Family
B	CPU speed	4	48 MHz
C	Flash capacity	4	16 KB
		5	32 KB
		6	64 KB
		7	128 KB
DE	Package code	AX, AZ	TQFP

7 Ordering information

Field	Description	Values	Meaning
		LQ	QFN
		BU	BGA
		FD	CSP
F	Temperature range	I	Industrial
		Q	Extended Industrial
S	Silicon family	N/A	PSoC™ 4 Base Series
		L	PSoC™ 4 L-Series
		BL	PSoC™ 4 BLE
		M	PSoC™ 4 M-Series
XYZ	Attributes code	000-999	Code of feature set in the specific family

7.1 Part numbering conventions

The part number fields are defined as follows.

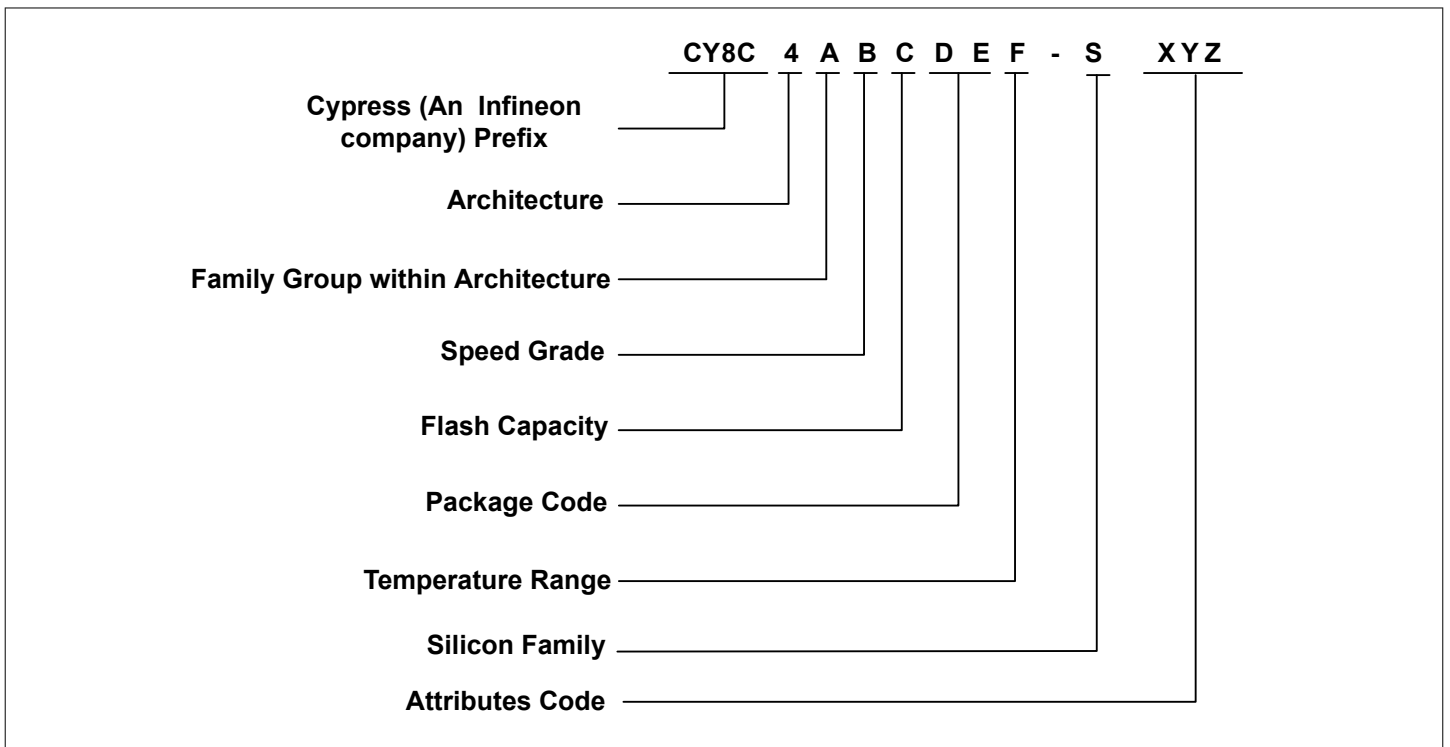

Figure 6 Part numbering conventions

8 Packaging

The description of the PSoC™ 4100M package dimensions follows.

Table 40 Package dimensions

Spec ID#	Package	Description	Package Dwg #
PKG_1	68-pin QFN	68-pin QFN, 8 mm x 8 mm x 1.0 mm height with 0.4 mm pitch	001-09618
PKG_2	64-pin TQFP	64-pin TQFP, 10 mm x 10 mm x 1.4 mm height with 0.5 mm pitch	51-85051
PKG_4	64-pin TQFP	64-pin TQFP, 14 mm x 14 mm x 1.4 mm height with 0.8 mm pitch	51-85046
PKG_5	48-pin TQFP	48-pin TQFP, 7 mm x 7 mm x 1.4 mm height with 0.5 mm pitch	51-85135
PKG_6	44-pin TQFP	44-pin TQFP, 10 mm x 10 mm x 1.4 mm height with 0.8 mm pitch	51-85064

Table 41 Package characteristics

Parameter	Description	Conditions	Min	Typ	Max	Unit
T _A	Operating ambient temperature	–	–40	25	85	°C
T _J	Operating junction temperature	–	–40	–	100	°C
T _{JA}	Package θ_{JA} (68-pin QFN)	–	–	16.8	–	°C/Watt
T _{JC}	Package θ_{JC} (68-pin QFN)	–	–	2.9	–	°C/Watt
T _{JA}	Package θ_{JA} (64-pin TQFP, 0.5-mm pitch)	–	–	56	–	°C/Watt
T _{JC}	Package θ_{JC} (64-pin TQFP, 0.5-mm pitch)	–	–	19.5	–	°C/Watt
T _{JA}	Package θ_{JA} (64-pin TQFP, 0.8-mm pitch)	–	–	66.4	–	°C/Watt
T _{JC}	Package θ_{JC} (64-pin TQFP, 0.8-mm pitch)	–	–	18.2	–	°C/Watt
T _{JA}	Package θ_{JA} (48-pin TQFP, 0.5-mm pitch)	–	–	67.3	–	°C/Watt
T _{JC}	Package θ_{JC} (48-pin TQFP, 0.5-mm pitch)	–	–	30.4	–	°C/Watt
T _{JA}	Package θ_{JA} (44-pin TQFP, 0.8-mm pitch)	–	–	57	–	°C/Watt
T _{JC}	Package θ_{JC} (44-pin TQFP, 0.8-mm pitch)	–	–	25.9	–	°C/Watt

Note: All θ_{JA} and θ_{JC} values are simulated, not characterized.

Table 42 Solder reflow peak temperature

Package	Maximum peak temperature	Maximum time at peak temperature
All packages	260°C	30 seconds

Table 43 Package moisture sensitivity level (MSL), IPC/JEDEC J-STD-2

Package	MSL
All packages	MSL 3

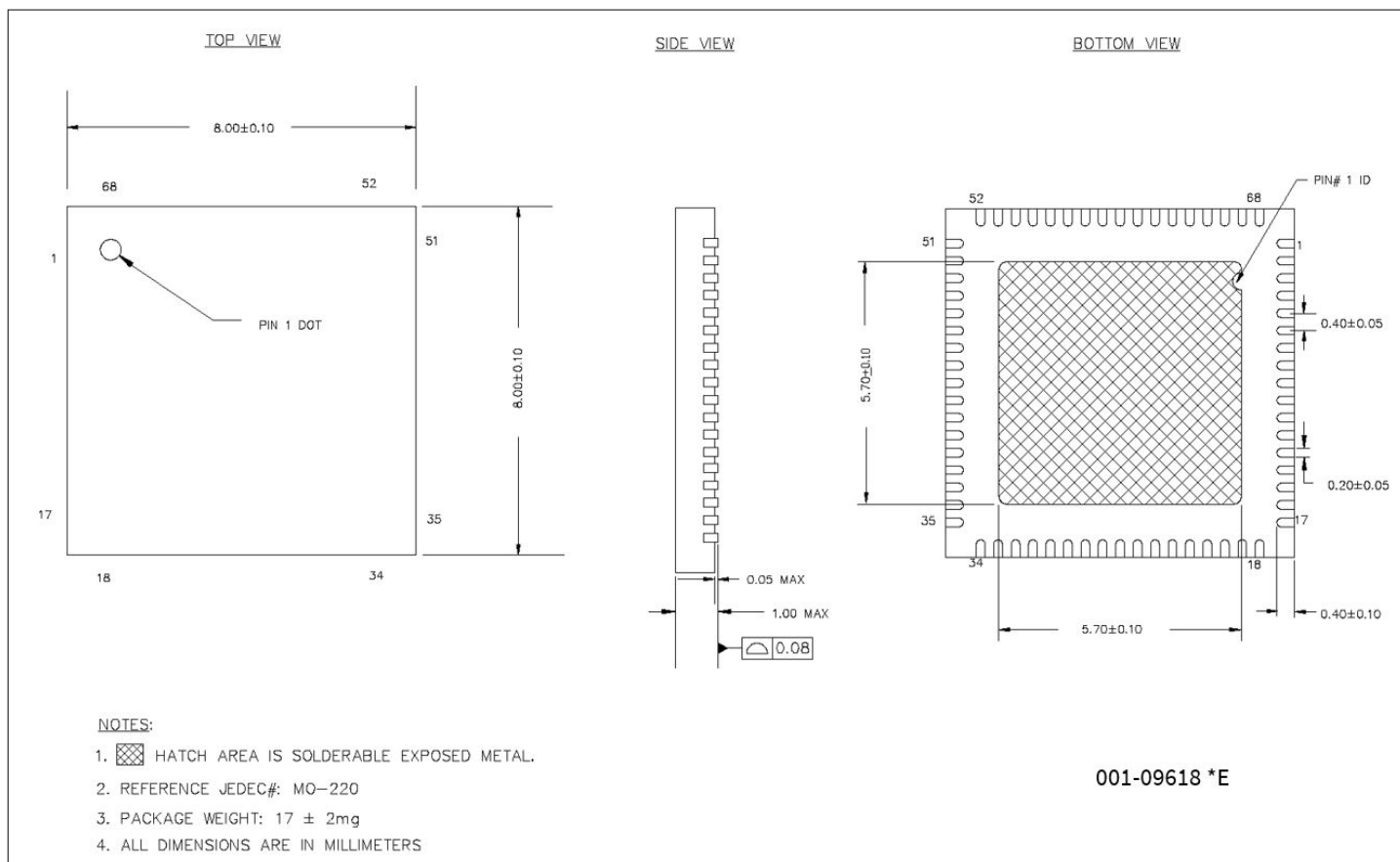

Figure 7 68-Pin QFN 8 × 8 × 1.0 mm package outline (PG-VQFN-68)

Note: The center pad on the QFN package should be connected to ground (VSS) for best mechanical, thermal, and electrical performance. If not connected to ground, it should be electrically floating and not connected to any other signal.

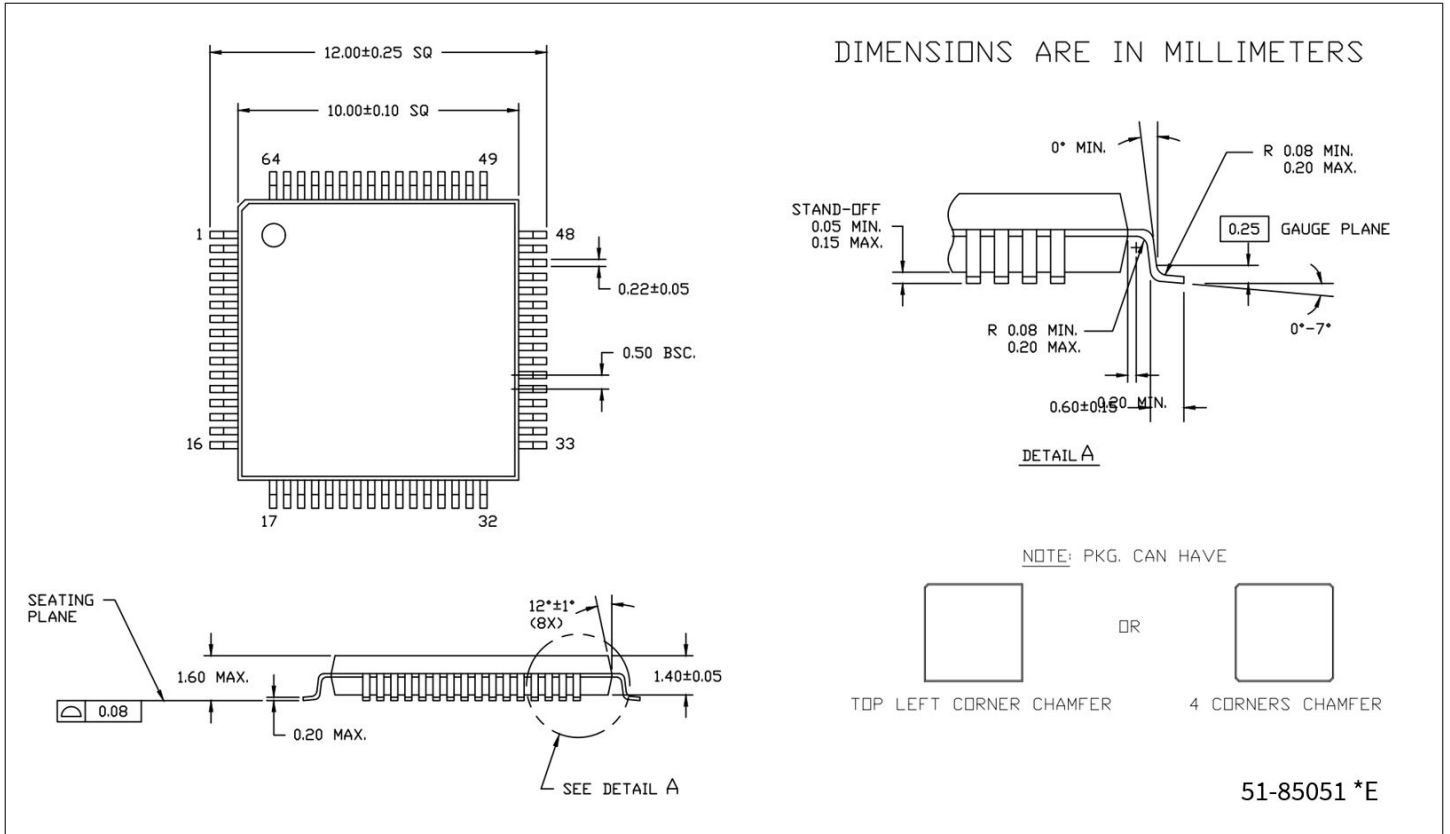

Figure 8 64-Pin TQFP 10 × 10 × 1.4 mm package outline (PG-TQFP-64)

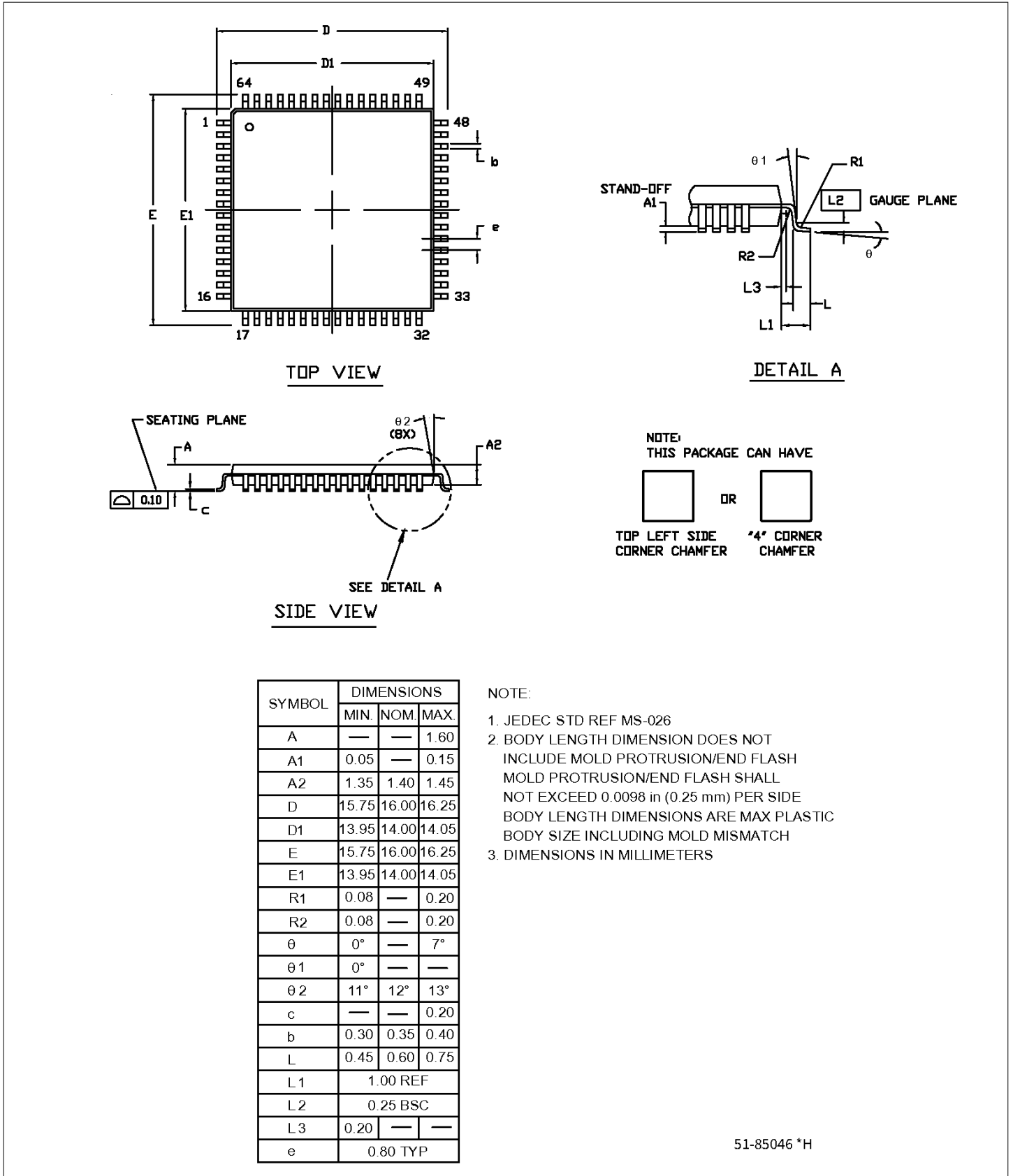

Figure 9 64-Pin 14 × 14 × 1.4 mm TQFP package outline (PG-TQFP-64)

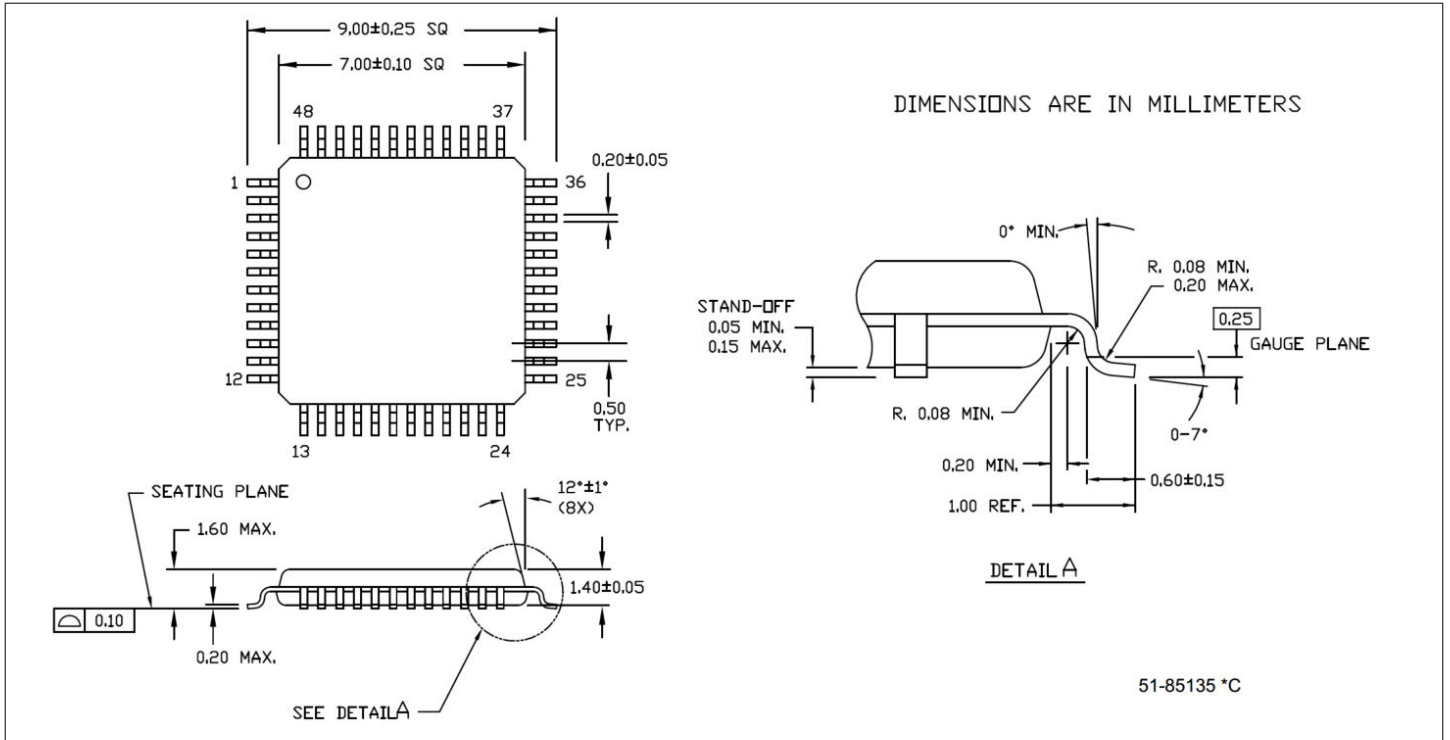

Figure 10 48-Pin 7 × 7 × 1.4 mm TQFP package outline (PG-TQFP-48)

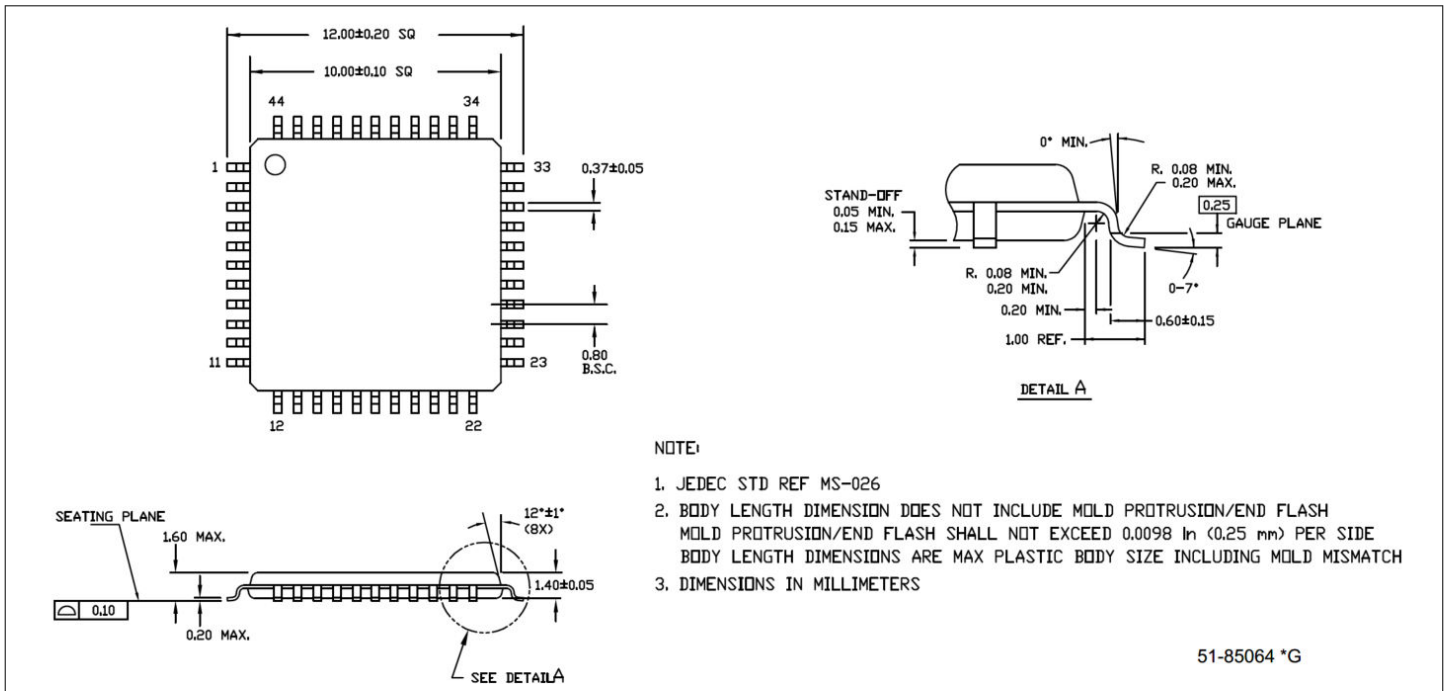

Figure 11 44-Pin 10 × 10 × 1.4 mm TQFP package outline (PG-TQFP-44)

9 Acronyms

Table 44 Acronyms used in this document

Acronym	Description
abus	analog local bus
ADC	analog-to-digital converter
AG	analog global
AHB	AMBA (advanced microcontroller bus architecture) high-performance bus, an Arm® data transfer bus
ALU	arithmetic logic unit
AMUXBUS	analog multiplexer bus
API	application programming interface
APSR	application program status register
Arm®	advanced RISC machine, a CPU architecture
ATM	automatic thump mode
BW	bandwidth
CAN	Controller Area Network, a communications protocol
CMRR	common-mode rejection ratio
CPU	central processing unit
CRC	cyclic redundancy check, an error-checking protocol
DAC	digital-to-analog converter, see also IDAC, VDAC
DFB	digital filter block
DIO	digital input/output, GPIO with only digital capabilities, no analog. See GPIO.
DMIPS	Dhrystone million instructions per second
DMA	direct memory access, see also TD
DNL	differential nonlinearity, see also INL
DNU	do not use
DR	port write data registers
DSI	digital system interconnect
DWT	data watchpoint and trace
ECC	error correcting code
ECO	external crystal oscillator
EEPROM	electrically erasable programmable read-only memory
EMI	electromagnetic interference
EMIF	external memory interface
EOC	end of conversion
EOF	end of frame

(table continues...)

Table 44 (continued) Acronyms used in this document

Acronym	Description
EPSR	execution program status register
ESD	electrostatic discharge
ETM	embedded trace macrocell
FIR	finite impulse response, see also IIR
FPB	flash patch and breakpoint
FS	full-speed
GPIO	general-purpose input/output, applies to a PSoC™ pin
HVI	high-voltage interrupt, see also LVI, LVD
IC	integrated circuit
IDAC	current DAC, see also DAC, VDAC
IDE	integrated development environment
I ² C, or IIC	Inter-Integrated Circuit, a communications protocol
IIR	infinite impulse response, see also FIR
ILO	internal low-speed oscillator, see also IMO
IMO	internal main oscillator, see also ILO
INL	integral nonlinearity, see also DNL
I/O	input/output, see also GPIO, DIO, SIO, USBIO
IPOR	initial power-on reset
IPSR	interrupt program status register
IRQ	interrupt request
ITM	instrumentation trace macrocell
LCD	liquid crystal display
LIN	Local Interconnect Network, a communications protocol.
LR	link register
LUT	lookup table
LVD	low-voltage detect, see also LVI
LVI	low-voltage interrupt, see also HVI
LVTTTL	low-voltage transistor-transistor logic
MAC	multiply-accumulate
MCU	microcontroller unit
MISO	master-in slave-out
NC	no connect
NMI	nonmaskable interrupt

(table continues...)

Table 44 (continued) Acronyms used in this document

Acronym	Description
NRZ	non-return-to-zero
NVIC	nested vectored interrupt controller
NVL	nonvolatile latch, see also WOL
opamp	operational amplifier
PAL	programmable array logic, see also PLD
PC	program counter
PCB	printed circuit board
PGA	programmable gain amplifier
PHUB	peripheral hub
PHY	physical layer
PICU	port interrupt control unit
PLA	programmable logic array
PLD	programmable logic device, see also PAL
PLL	phase-locked loop
PMDD	package material declaration data sheet
POR	power-on reset
PRES	precise power-on reset
PRS	pseudo random sequence
PS	port read data register
PSoC™	Programmable System-on-Chip™
PSRR	power supply rejection ratio
PWM	pulse-width modulator
RAM	random-access memory
RISC	reduced-instruction-set computing
RMS	root-mean-square
RTC	real-time clock
RTL	register transfer language
RTR	remote transmission request
RX	receive
SAR	successive approximation register
SC/CT	switched capacitor/continuous time
SCL	I2C serial clock
SDA	I2C serial data

(table continues...)

Table 44 (continued) Acronyms used in this document

Acronym	Description
S/H	sample and hold
SINAD	signal to noise and distortion ratio
SIO	special input/output, GPIO with advanced features. See GPIO.
SOC	start of conversion
SOF	start of frame
SPI	Serial Peripheral Interface, a communications protocol
SR	slew rate
SRAM	static random access memory
SRES	software reset
SWD	serial wire debug, a test protocol
SWV	single-wire viewer
TD	transaction descriptor, see also DMA
THD	total harmonic distortion
TIA	transimpedance amplifier
TRM	technical reference manual
TTL	transistor-transistor logic
TX	transmit
UART	Universal Asynchronous Transmitter Receiver, a communications protocol
UDB	universal digital block
USB	Universal Serial Bus
USBIO	USB input/output, PSoC™ pins used to connect to a USB port
VDAC	voltage DAC, see also DAC, IDAC
WDT	watchdog timer
WOL	write once latch, see also NVL
WRES	watchdog timer reset
XRES	external reset I/O pin
XTAL	crystal

10 Document conventions

10.1 Units of measure

Table 45 Unit of measure

Symbol	Unit of measure
°C	degrees celsius
dB	decibel
fF	femto farad
Hz	hertz
KB	1024 bytes
kbps	kilobits per second
Khr	kilohour
kHz	kilohertz
kΩ	kilo ohm
ksps	kilosamples per second
LSB	least significant bit
Mbps	megabits per second
MHz	megahertz
MΩ	mega-ohm
Msps	megasamples per second
μA	microampere
μF	microfarad
μH	microhenry
μs	microsecond
μV	microvolt
μW	microwatt
mA	milliampere
ms	millisecond
mV	millivolt
nA	nanoampere
ns	nanosecond
nV	nanovolt
Ω	ohm
pF	picofarad
ppm	parts per million
ps	picosecond

(table continues...)

Table 45 (continued) **Unit of measure**

Symbol	Unit of measure
s	second
sps	samples per second
sqrtHz	square root of hertz
V	volt

11 Revision history

Document revision	Date	Description of changes
*A	2015-05-20	Release to web.
*B	2015-06-29	Removed note regarding hardware handshaking in the UART Mode section. Changed max value of SID51A to 2 ms. Added “Guaranteed by characterization” note for SID65 and SID65A Updated Ordering Information.
*C	2015-09-30	Updated CAPSENSE™ section. Updated the note at the end of the Pinout table. Removed Conditions for spec SID237.
*D	2015-11-26	Added Comparator ULP mode range restrictions and corrected typos.
*E	2016-08-19	Added extended industrial temperature range. Added specs SID290Q, SID182A, and SID299A. Updated conditions for SID290, SID223, and SID237. Added 44-pin TQFP package details. Updated Ordering Information
*F	2017-04-26	Updated the Cypress logo and copyright information. Updated 64-TQFP package diagram.
*G	2018-03-28	Corrected MPN Table to show three SCBs for 48 TQFP packages and two SBCs for 44 TQFP package.
*H	2024-02-16	Migrated to IFX template. Deleted DN VSSD pins from Pinout. Added Note in Packaging. Updated Development ecosystem Updated 64-Pin TQFP package diagram Deleted Reference section

Trademarks

All referenced product or service names and trademarks are the property of their respective owners.

Edition 2024-02-16

Published by

Infineon Technologies AG

81726 Munich, Germany

© 2024 Infineon Technologies AG

All Rights Reserved.

Do you have a question about any aspect of this document?

Email: erratum@infineon.com

Document reference

IFX-ncf1693213497890

Important notice

The information given in this document shall in no event be regarded as a guarantee of conditions or characteristics ("Beschaffheitsgarantie").

With respect to any examples, hints or any typical values stated herein and/or any information regarding the application of the product, Infineon Technologies hereby disclaims any and all warranties and liabilities of any kind, including without limitation warranties of non-infringement of intellectual property rights of any third party.

In addition, any information given in this document is subject to customer's compliance with its obligations stated in this document and any applicable legal requirements, norms and standards concerning customer's products and any use of the product of Infineon Technologies in customer's applications.

The data contained in this document is exclusively intended for technically trained staff. It is the responsibility of customer's technical departments to evaluate the suitability of the product for the intended application and the completeness of the product information given in this document with respect to such application.



Warnings

Due to technical requirements products may contain dangerous substances. For information on the types in question please contact your nearest Infineon Technologies office.



Except as otherwise explicitly approved by Infineon Technologies in a written document signed by authorized representatives of Infineon Technologies, Infineon Technologies' products may not be used in any applications where a failure of the product or any consequences of the use thereof can reasonably be expected to result in personal injury.

Looking for pricing, stock, or lifecycle information?

Click below to explore more details on WIN SOURCE:

-  [View CY8C4126AXI-M443 on WIN SOURCE](#)
-  [Infineon Technologies Information](#)

Optimize Your Supply Chain with WIN SOURCE Solutions

-  Global Sourcing Solution
-  Obsolete Management
-  Cost Control Management
-  Shortage Management
-  Alternative Solution
-  Excess Inventory Management