



THE DATASHEET OF TLV431BLPG



TLV431, NCV431, SCV431

Low Voltage Precision Adjustable Shunt Regulator

The TLV431A, B and C series are precision low voltage shunt regulators that are programmable over a wide voltage range of 1.24 V to 16 V. The TLV431A series features a guaranteed reference accuracy of $\pm 1.0\%$ at 25°C and $\pm 2.0\%$ over the entire industrial temperature range of -40°C to 85°C. The TLV431B series features higher reference accuracy of $\pm 0.5\%$ and $\pm 1.0\%$ respectively. For the TLV431C series, the accuracy is even higher. It is $\pm 0.2\%$ and $\pm 1.0\%$ respectively. These devices exhibit a sharp low current turn-on characteristic with a low dynamic impedance of 0.20 Ω over an operating current range of 100 μA to 20 mA. This combination of features makes this series an excellent replacement for zener diodes in numerous applications circuits that require a precise reference voltage. When combined with an optocoupler, the TLV431A/B/C can be used as an error amplifier for controlling the feedback loop in isolated low output voltage (3.0 V to 3.3 V) switching power supplies. These devices are available in economical TO-92-3 and micro size TSOP-5 and SOT-23-3 packages.

Features

- Programmable Output Voltage Range of 1.24 V to 16 V
- Voltage Reference Tolerance $\pm 1.0\%$ for A Series, $\pm 0.5\%$ for B Series and $\pm 0.2\%$ for C Series
- Sharp Low Current Turn-On Characteristic
- Low Dynamic Output Impedance of 0.20 Ω from 100 μA to 20 mA
- Wide Operating Current Range of 50 μA to 20 mA
- Micro Miniature TSOP-5, SOT-23-3 and TO-92-3 Packages
- NCV and SCV Prefix for Automotive and Other Applications Requiring Unique Site and Control Change Requirements; AEC-Q100 Qualified and PPAP Capable
- These are Pb-Free and Halide-Free Devices

Applications

- Low Output Voltage (3.0 V to 3.3 V) Switching Power Supply Error Amplifier
- Adjustable Voltage or Current Linear and Switching Power Supplies
- Voltage Monitoring
- Current Source and Sink Circuits
- Analog and Digital Circuits Requiring Precision References
- Low Voltage Zener Diode Replacements

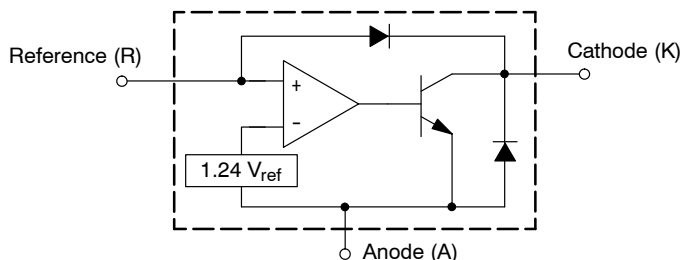
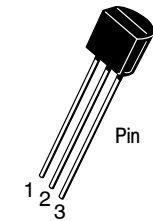

Figure 1. Representative Block Diagram



ON Semiconductor®

www.onsemi.com



STRAIGHT LEAD
BULK PACK

TO-92
LP SUFFIX
CASE 29-11

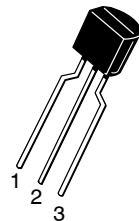

BENT LEAD
TAPE & REEL
AMMO PACK

TO-92
LPRA, LPRE, LPRM,
LPRP SUFFIX
CASE 29-11

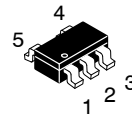

Pin 1. NC
2. NC
3. Cathode
4. Reference
5. Anode

TSOP-5
SN SUFFIX
CASE 483

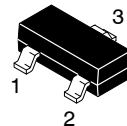

Pin 1. Reference
2. Cathode
3. Anode

SOT-23
SN1 SUFFIX
CASE 318

ORDERING INFORMATION

See detailed ordering and shipping information in the package dimensions section on page 14 of this data sheet.

DEVICE MARKING INFORMATION AND PIN CONNECTIONS

See general marking information in the device marking section on page 13 of this data sheet.

TLV431, NCV431, SCV431

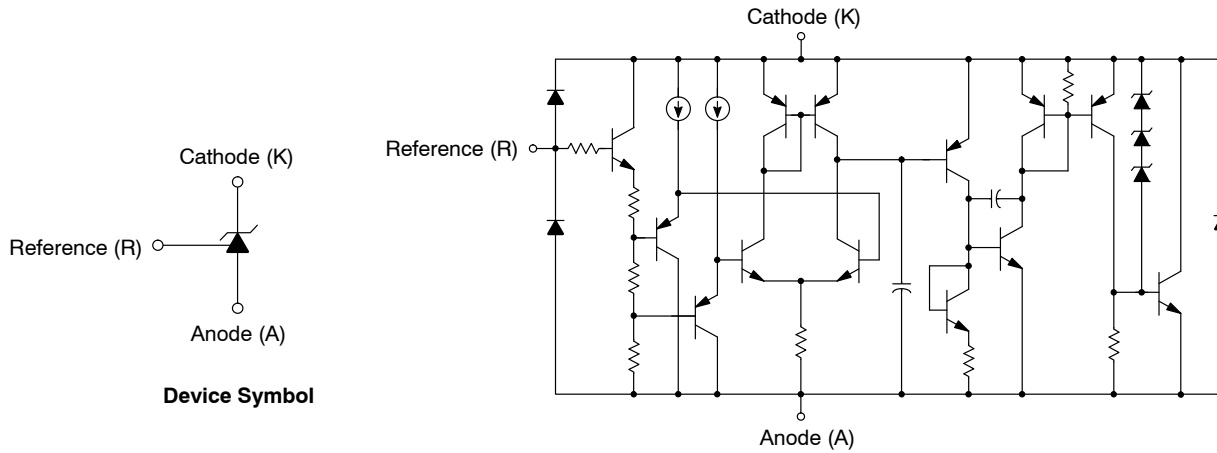

The device contains 13 active transistors.

Figure 2. Representative Device Symbol and Schematic Diagram

MAXIMUM RATINGS (Full operating ambient temperature range applies, unless otherwise noted)

Rating	Symbol	Value	Unit
Cathode to Anode Voltage	V_{KA}	18	V
Cathode Current Range, Continuous	I_K	-20 to 25	mA
Reference Input Current Range, Continuous	I_{ref}	-0.05 to 10	mA
Thermal Characteristics			$^{\circ}C/W$
LP Suffix Package, TO-92-3 Package			
Thermal Resistance, Junction-to-Ambient	$R_{\theta JA}$	178	
Thermal Resistance, Junction-to-Case	$R_{\theta JC}$	83	
SN Suffix Package, TSOP-5 Package			
Thermal Resistance, Junction-to-Ambient	$R_{\theta JA}$	226	
SN1 Suffix Package, SOT-23-3 Package			
Thermal Resistance, Junction-to-Ambient	$R_{\theta JA}$	491	
Operating Junction Temperature	T_J	150	$^{\circ}C$
Operating Ambient Temperature Range	T_A	-40 to 85 -40 to 125	$^{\circ}C$
Storage Temperature Range	T_{stg}	-65 to 150	$^{\circ}C$

Stresses exceeding those listed in the Maximum Ratings table may damage the device. If any of these limits are exceeded, device functionality should not be assumed, damage may occur and reliability may be affected.

NOTE: This device series contains ESD protection and exceeds the following tests:

Human Body Model 2000 V per JEDEC JESD22-A114F, Machine Model Method 200 V per JEDEC JESD22-A115C,

Charged Device Method 1000 V per JEDEC JESD22-C101E. This device contains latch-up protection and exceeds ± 100 mA per JEDEC standard JESD78.

$$P_D = \frac{T_{J(max)} - T_A}{R_{\theta JA}}$$

RECOMMENDED OPERATING CONDITIONS

Condition	Symbol	Min	Max	Unit
Cathode to Anode Voltage	V_{KA}	V_{ref}	16	V
Cathode Current	I_K	0.1	20	mA

Functional operation above the stresses listed in the Recommended Operating Ranges is not implied. Extended exposure to stresses beyond the Recommended Operating Ranges limits may affect device reliability.

TLV431, NCV431, SCV431

ELECTRICAL CHARACTERISTICS (T_A = 25°C unless otherwise noted)

Characteristic	Symbol	TLV431A			TLV431B			Unit
		Min	Typ	Max	Min	Typ	Max	
Reference Voltage (Figure 3) (V _{KA} = V _{ref} , I _K = 10 mA, T _A = 25°C) (T _A = T _{low} to T _{high} , Note 1)	V _{ref}	1.228 1.215	1.240 –	1.252 1.265	1.234 1.228	1.240 –	1.246 1.252	V
Reference Input Voltage Deviation Over Temperature (Figure 3) (V _{KA} = V _{ref} , I _K = 10 mA, T _A = T _{low} to T _{high} , Notes 1, 2, 3)	ΔV _{ref}	–	7.2	20	–	7.2	20	mV
Ration of Reference Input Voltage Change to Cathode Voltage Change (Figure 4) (V _{KA} = V _{ref} to 16 V, I _K = 10 mA)	$\frac{\Delta V_{ref}}{\Delta V_{KA}}$	–	–0.6	–1.5	–	–0.6	–1.5	$\frac{mV}{V}$
Reference Terminal Current (Figure 4) (I _K = 10 mA, R1 = 10 kΩ, R2 = open)	I _{ref}	–	0.15	0.3	–	0.15	0.3	μA
Reference Input Current Deviation Over Temperature (Figure 4) (I _K = 10 mA, R1 = 10 kΩ, R2 = open, Notes 1, 2, 3)	ΔI _{ref}	–	0.04	0.08	–	0.04	0.08	μA
Minimum Cathode Current for Regulation (Figure 3)	I _{K(min)}	–	30	80	–	30	80	μA
Off-State Cathode Current (Figure 5) (V _{KA} = 6.0 V, V _{ref} = 0) (V _{KA} = 16 V, V _{ref} = 0)	I _{K(off)}	– –	0.01 0.012	0.04 0.05	– –	0.01 0.012	0.04 0.05	μA
Dynamic Impedance (Figure 3) (V _{KA} = V _{ref} , I _K = 0.1 mA to 20 mA, f ≤ 1.0 kHz, Note 4)	Z _{KA}	–	0.25	0.4	–	0.25	0.4	Ω

1. Ambient temperature range: T_{low} = –40°C, T_{high} = 85°C.

2. Guaranteed but not tested.

3. The deviation parameters ΔV_{ref} and ΔI_{ref} are defined as the difference between the maximum value and minimum value obtained over the full operating ambient temperature range that applied.

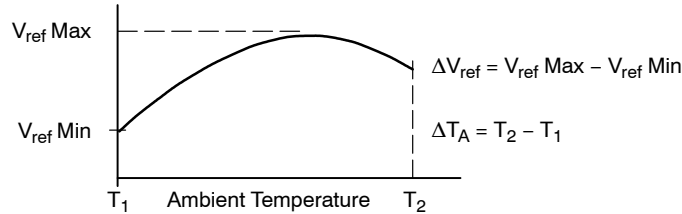

The average temperature coefficient of the reference input voltage, αV_{ref} is defined as:

$$\alpha V_{ref} \left(\frac{\text{ppm}}{^{\circ}\text{C}} \right) = \frac{\left(\frac{\Delta V_{ref}}{V_{ref} (T_A = 25^{\circ}\text{C})} \times 10^6 \right)}{\Delta T_A}$$

αV_{ref} can be positive or negative depending on whether V_{ref} Min or V_{ref} Max occurs at the lower ambient temperature, refer to Figure 8.

Example: ΔV_{ref} = 7.2 mV and the slope is positive,

$$V_{ref} @ 25^{\circ}\text{C} = 1.241 \text{ V}$$

$$\Delta T_A = 125^{\circ}\text{C}$$

$$\alpha V_{ref} \left(\frac{\text{ppm}}{^{\circ}\text{C}} \right) = \frac{0.0072 \times 10^6}{1.241 \times 125} = 46 \text{ ppm}/^{\circ}\text{C}$$

4. The dynamic impedance Z_{KA} is defined as:

$$|Z_{KA}| = \frac{\Delta V_{KA}}{\Delta I_K}$$

When the device is operating with two external resistors, R1 and R2, (refer to Figure 4) the total dynamic impedance of the circuit is given by:

$$|Z_{KA}'| = |Z_{KA}| \times \left(1 + \frac{R1}{R2} \right)$$

TLV431, NCV431, SCV431

ELECTRICAL CHARACTERISTICS (T_A = 25°C unless otherwise noted)

Characteristic	Symbol	TLV431C			Unit
		Min	Typ	Max	
Reference Voltage (Figure 3) (V _{KA} = V _{ref} , I _K = 10 mA, T _A = 25°C) (T _A = T _{low} to T _{high} , Note 5)	V _{ref}	1.237 1.228	1.240 –	1.243 1.252	V
Reference Input Voltage Deviation Over Temperature (Figure 3) (V _{KA} = V _{ref} , I _K = 10 mA, T _A = T _{low} to T _{high} , Notes 5, 6, 7)	ΔV _{ref}	–	7.2	2.0	mV
Ration of Reference Input Voltage Change to Cathode Voltage Change (Figure 4) (V _{KA} = V _{ref} to 16 V, I _K = 10 mA)	$\frac{\Delta V_{ref}}{\Delta V_{KA}}$	–	–0.6	–1.5	$\frac{mV}{V}$
Reference Terminal Current (Figure 4) (I _K = 10 mA, R1 = 10 kΩ, R2 = open)	I _{ref}	–	0.15	0.3	μA
Reference Input Current Deviation Over Temperature (Figure 4) (I _K = 10 mA, R1 = 10 kΩ, R2 = open, Notes 5, 6, 7)	ΔI _{ref}	–	0.04	0.08	μA
Minimum Cathode Current for Regulation (Figure 3)	I _{K(min)}	–	30	80	μA
Off-State Cathode Current (Figure 5) (V _{KA} = 6.0 V, V _{ref} = 0) (V _{KA} = 16 V, V _{ref} = 0)	I _{K(off)}	– –	0.01 0.012	0.04 0.05	μA
Dynamic Impedance (Figure 3) (V _{KA} = V _{ref} , I _K = 0.1 mA to 20 mA, f ≤ 1.0 kHz, Note 8)	Z _{KA}	–	0.25	0.4	Ω

5. Ambient temperature range: T_{low} = –40°C, T_{high} = 85°C.

6. Guaranteed but not tested.

7. The deviation parameters ΔV_{ref} and ΔI_{ref} are defined as the difference between the maximum value and minimum value obtained over the full operating ambient temperature range that applied.

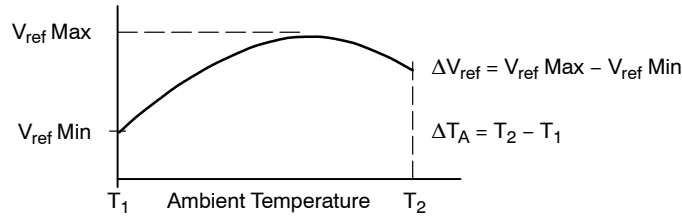

The average temperature coefficient of the reference input voltage, αV_{ref} is defined as:

$$\alpha V_{ref} \left(\frac{\text{ppm}}{^{\circ}\text{C}} \right) = \frac{\left(\frac{\Delta V_{ref}}{V_{ref} (T_A = 25^{\circ}\text{C})} \times 10^6 \right)}{\Delta T_A}$$

αV_{ref} can be positive or negative depending on whether V_{ref} Min or V_{ref} Max occurs at the lower ambient temperature, refer to Figure 8.

Example: ΔV_{ref} = 7.2 mV and the slope is positive,

$$V_{ref} @ 25^{\circ}\text{C} = 1.241 \text{ V}$$

$$\Delta T_A = 125^{\circ}\text{C}$$

$$\alpha V_{ref} \left(\frac{\text{ppm}}{^{\circ}\text{C}} \right) = \frac{0.0072 \times 10^6}{1.241 \times 125} = 46 \text{ ppm}/^{\circ}\text{C}$$

8. The dynamic impedance Z_{KA} is defined as:

$$|Z_{KA}| = \frac{\Delta V_{KA}}{\Delta I_K}$$

When the device is operating with two external resistors, R1 and R2, (refer to Figure 4) the total dynamic impedance of the circuit is given by:

$$|Z_{KA}'| = |Z_{KA}| \times \left(1 + \frac{R1}{R2} \right)$$

TLV431, NCV431, SCV431

ELECTRICAL CHARACTERISTICS ($T_A = 25^\circ\text{C}$ unless otherwise noted. NCV prefix indicates TSOP package device. SCV prefix indicates SOT-23 package device.)

Characteristic	Symbol	NCV431A, SCV431A			Unit
		Min	Typ	Max	
Reference Voltage (Figure 3) ($V_{KA} = V_{ref}$, $I_K = 10\text{ mA}$, $T_A = 25^\circ\text{C}$) ($T_A = -40^\circ\text{C}$ to 85°C) ($T_A = -40^\circ\text{C}$ to 125°C)	V_{ref}	1.228 1.215 1.211	1.240 – –	1.252 1.265 1.265	V
Reference Input Voltage Deviation Over Temperature (Figure 3) ($V_{KA} = V_{ref}$, $I_K = 10\text{ mA}$, $T_A = -40^\circ\text{C}$ to 85°C , Notes 9, 10) ($V_{KA} = V_{ref}$, $I_K = 10\text{ mA}$, $T_A = -40^\circ\text{C}$ to 125°C , Notes 9, 10)	ΔV_{ref}	– –	7.2 7.2	20 24	mV
Ration of Reference Input Voltage Change to Cathode Voltage Change (Figure 4) ($V_{KA} = V_{ref}$ to 16 V, $I_K = 10\text{ mA}$)	$\frac{\Delta V_{ref}}{\Delta V_{KA}}$	–	–0.6	–1.5	$\frac{\text{mV}}{\text{V}}$
Reference Terminal Current (Figure 4) ($I_K = 10\text{ mA}$, $R1 = 10\text{ k}\Omega$, $R2 = \text{open}$)	I_{ref}	–	0.15	0.3	μA
Reference Input Current Deviation Over Temperature (Figure 4) ($I_K = 10\text{ mA}$, $R1 = 10\text{ k}\Omega$, $R2 = \text{open}$, $T_A = -40^\circ\text{C}$ to 85°C , Notes 9, 10) ($I_K = 10\text{ mA}$, $R1 = 10\text{ k}\Omega$, $R2 = \text{open}$, $T_A = -40^\circ\text{C}$ to 125°C , Notes 9, 10)	ΔI_{ref}	– –	0.04 –	0.08 0.10	μA
Minimum Cathode Current for Regulation (Figure 3)	$I_{K(\text{min})}$	–	30	80	μA
Off-State Cathode Current (Figure 5) ($V_{KA} = 6.0\text{ V}$, $V_{ref} = 0$) ($V_{KA} = 16\text{ V}$, $V_{ref} = 0$)	$I_{K(\text{off})}$	– –	0.01 0.012	0.04 0.05	μA
Dynamic Impedance (Figure 3) ($V_{KA} = V_{ref}$, $I_K = 0.1\text{ mA}$ to 20 mA , $f \leq 1.0\text{ kHz}$, Note 11)	$ Z_{KA} $	–	0.25	0.4	Ω

9. Guaranteed but not tested.

10. The deviation parameters ΔV_{ref} and ΔI_{ref} are defined as the difference between the maximum value and minimum value obtained over the full operating ambient temperature range that applied.

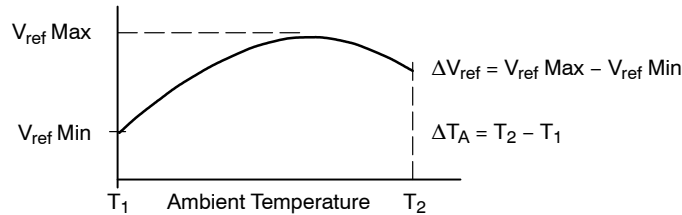

The average temperature coefficient of the reference input voltage, αV_{ref} is defined as:

$$\alpha V_{ref} \left(\frac{\text{ppm}}{^\circ\text{C}} \right) = \frac{\left(\frac{\Delta V_{ref}}{V_{ref} (T_A = 25^\circ\text{C})} \times 10^6 \right)}{\Delta T_A}$$

αV_{ref} can be positive or negative depending on whether V_{ref} Min or V_{ref} Max occurs at the lower ambient temperature, refer to Figure 8.

Example: $\Delta V_{ref} = 7.2\text{ mV}$ and the slope is positive,

$$V_{ref} @ 25^\circ\text{C} = 1.241\text{ V}$$

$$\Delta T_A = 125^\circ\text{C}$$

$$\alpha V_{ref} \left(\frac{\text{ppm}}{^\circ\text{C}} \right) = \frac{0.0072 \times 10^6}{125} = 46\text{ ppm}/^\circ\text{C}$$

11. The dynamic impedance Z_{KA} is defined as:

$$|Z_{KA}| = \frac{\Delta V_{KA}}{\Delta I_K}$$

When the device is operating with two external resistors, $R1$ and $R2$, (refer to Figure 4) the total dynamic impedance of the circuit is given by:

$$|Z_{KA}'| = |Z_{KA}| \times \left(1 + \frac{R1}{R2} \right)$$

TLV431, NCV431, SCV431

ELECTRICAL CHARACTERISTICS ($T_A = 25^\circ\text{C}$ unless otherwise noted. NCV prefix indicates TSOP package device. SCV prefix indicates SOT-23 package device.)

Characteristic	Symbol	NCV431B, SCV431B			Unit
		Min	Typ	Max	
Reference Voltage (Figure 3) ($V_{KA} = V_{ref}$, $I_K = 10\text{ mA}$, $T_A = 25^\circ\text{C}$) ($T_A = -40^\circ\text{C}$ to 85°C) ($T_A = -40^\circ\text{C}$ to 125°C)	V_{ref}	1.234 1.228 1.224	1.240 – –	1.246 1.252 1.252	V
Reference Input Voltage Deviation Over Temperature (Figure 3) ($V_{KA} = V_{ref}$, $I_K = 10\text{ mA}$, $T_A = -40^\circ\text{C}$ to 85°C , Notes 9, 10) ($V_{KA} = V_{ref}$, $I_K = 10\text{ mA}$, $T_A = -40^\circ\text{C}$ to 125°C , Notes 9, 10)	ΔV_{ref}	– –	7.2 7.2	20 24	mV
Ration of Reference Input Voltage Change to Cathode Voltage Change (Figure 4) ($V_{KA} = V_{ref}$ to 16 V, $I_K = 10\text{ mA}$)	$\frac{\Delta V_{ref}}{\Delta V_{KA}}$	–	–0.6	–1.5	$\frac{\text{mV}}{\text{V}}$
Reference Terminal Current (Figure 4) ($I_K = 10\text{ mA}$, $R1 = 10\text{ k}\Omega$, $R2 = \text{open}$)	I_{ref}	–	0.15	0.3	μA
Reference Input Current Deviation Over Temperature (Figure 4) ($I_K = 10\text{ mA}$, $R1 = 10\text{ k}\Omega$, $R2 = \text{open}$, $T_A = -40^\circ\text{C}$ to 85°C , Notes 12, 13) ($I_K = 10\text{ mA}$, $R1 = 10\text{ k}\Omega$, $R2 = \text{open}$, $T_A = -40^\circ\text{C}$ to 125°C , Notes 12, 13)	ΔI_{ref}	– –	0.04 –	0.08 0.10	μA
Minimum Cathode Current for Regulation (Figure 3)	$I_{K(\text{min})}$	–	30	80	μA
Off-State Cathode Current (Figure 5) ($V_{KA} = 6.0\text{ V}$, $V_{ref} = 0$) ($V_{KA} = 16\text{ V}$, $V_{ref} = 0$)	$I_{K(\text{off})}$	– –	0.01 0.012	0.04 0.05	μA
Dynamic Impedance (Figure 3) ($V_{KA} = V_{ref}$, $I_K = 0.1\text{ mA}$ to 20 mA , $f \leq 1.0\text{ kHz}$, Note 14)	$ Z_{KA} $	–	0.25	0.4	Ω

12. Guaranteed but not tested.

13. The deviation parameters ΔV_{ref} and ΔI_{ref} are defined as the difference between the maximum value and minimum value obtained over the full operating ambient temperature range that applied.

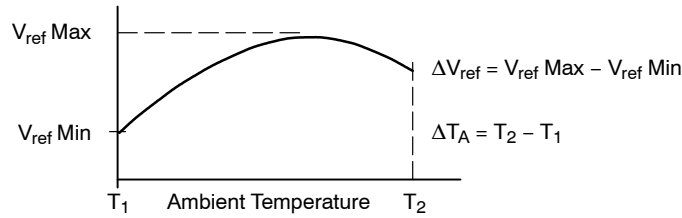

The average temperature coefficient of the reference input voltage, αV_{ref} is defined as:

$$\alpha V_{ref} \left(\frac{\text{ppm}}{^\circ\text{C}} \right) = \frac{\left(\frac{\Delta V_{ref}}{V_{ref} (T_A = 25^\circ\text{C})} \times 10^6 \right)}{\Delta T_A}$$

αV_{ref} can be positive or negative depending on whether V_{ref} Min or V_{ref} Max occurs at the lower ambient temperature, refer to Figure 8.

Example: $\Delta V_{ref} = 7.2\text{ mV}$ and the slope is positive,

$$V_{ref} @ 25^\circ\text{C} = 1.241\text{ V}$$

$$\Delta T_A = 125^\circ\text{C}$$

$$\alpha V_{ref} \left(\frac{\text{ppm}}{^\circ\text{C}} \right) = \frac{0.0072 \times 10^6}{125} = 46\text{ ppm}/^\circ\text{C}$$

14. The dynamic impedance Z_{KA} is defined as:

$$|Z_{KA}| = \frac{\Delta V_{KA}}{\Delta I_K}$$

When the device is operating with two external resistors, $R1$ and $R2$, (refer to Figure 4) the total dynamic impedance of the circuit is given by:

$$|Z_{KA}'| = |Z_{KA}| \times \left(1 + \frac{R1}{R2} \right)$$

TLV431, NCV431, SCV431

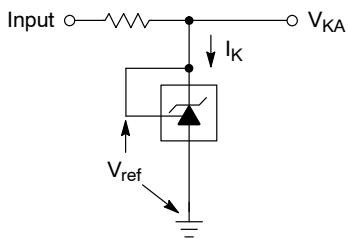

Figure 3. Test Circuit for $V_{KA} = V_{ref}$

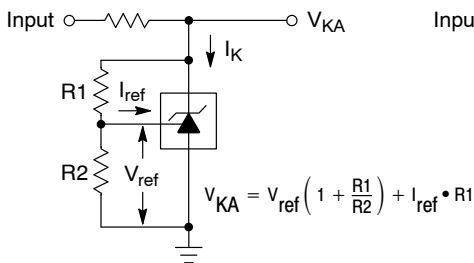

Figure 4. Test Circuit for $V_{KA} > V_{ref}$

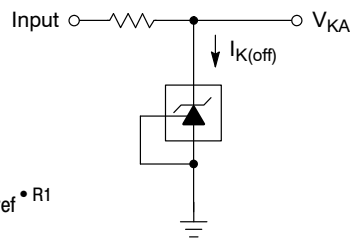

Figure 5. Test Circuit for $I_{K(off)}$

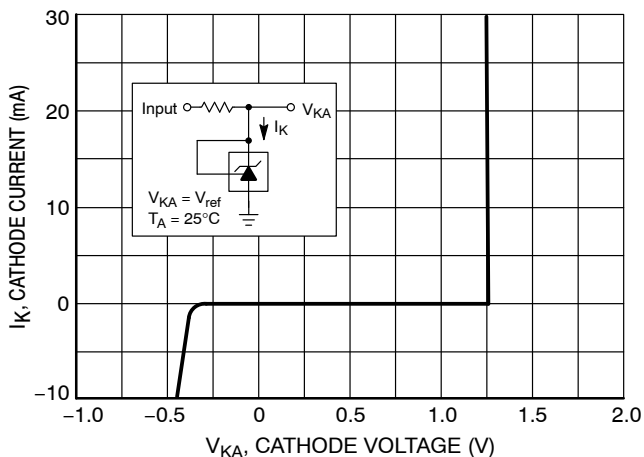

Figure 6. Cathode Current vs. Cathode Voltage

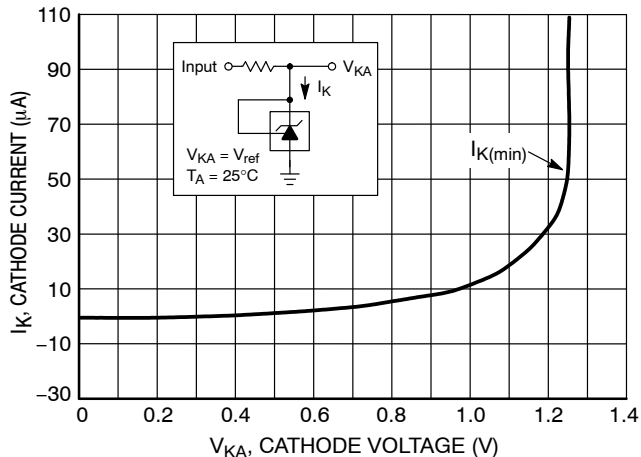

Figure 7. Cathode Current vs. Cathode Voltage

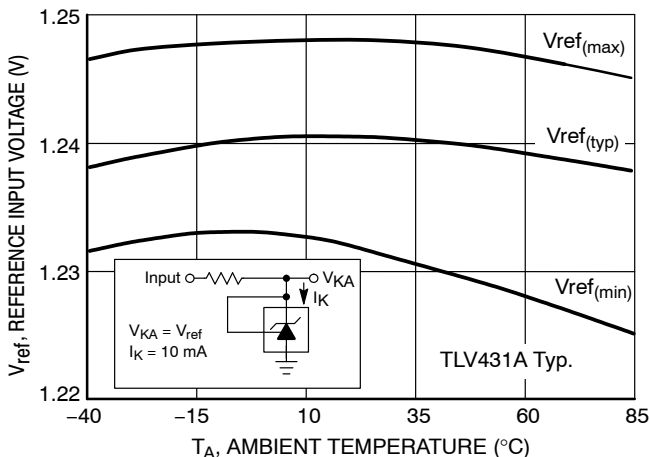

Figure 8. Reference Input Voltage versus Ambient Temperature

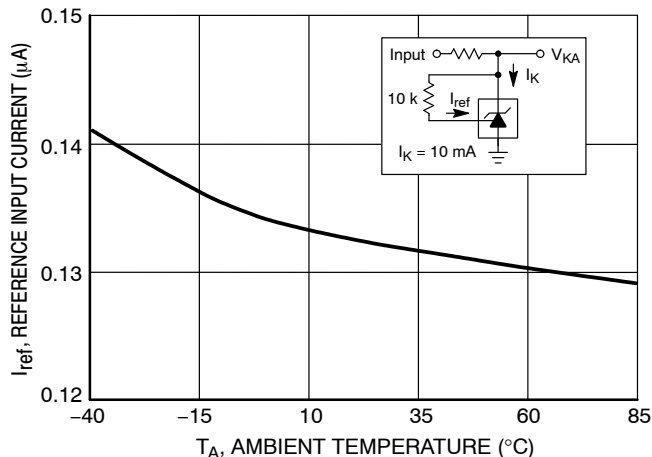

Figure 9. Reference Input Current versus Ambient Temperature

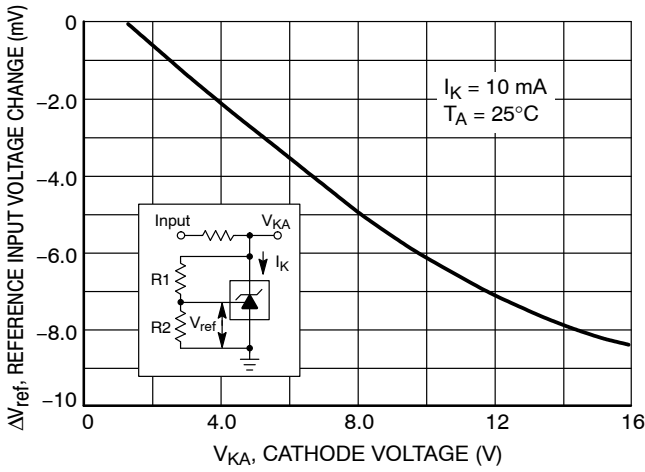

Figure 10. Reference Input Voltage Change versus Cathode Voltage

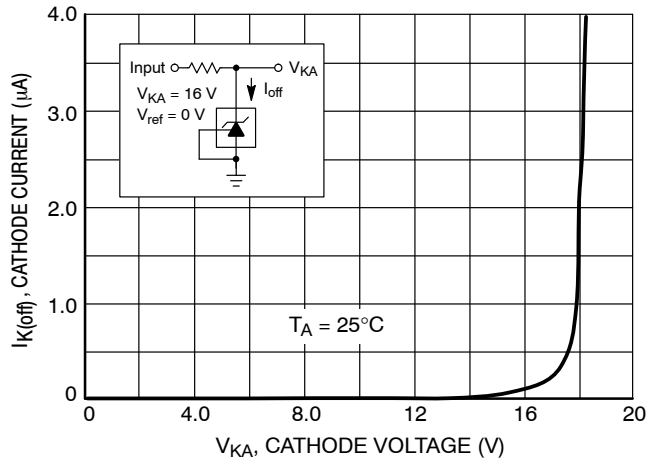

Figure 11. Off-State Cathode Current versus Cathode Voltage

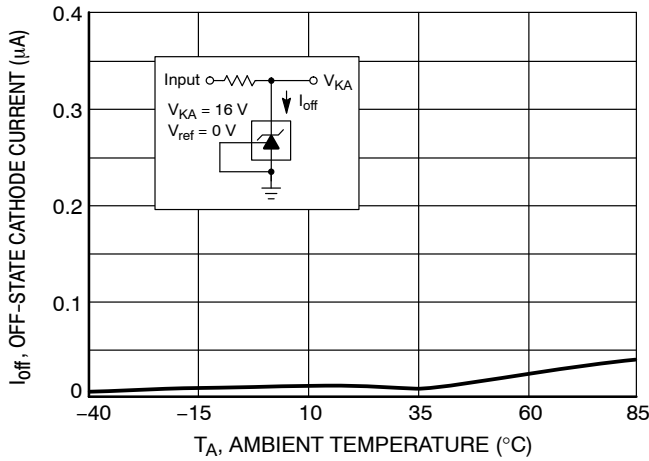

Figure 12. Off-State Cathode Current versus Ambient Temperature

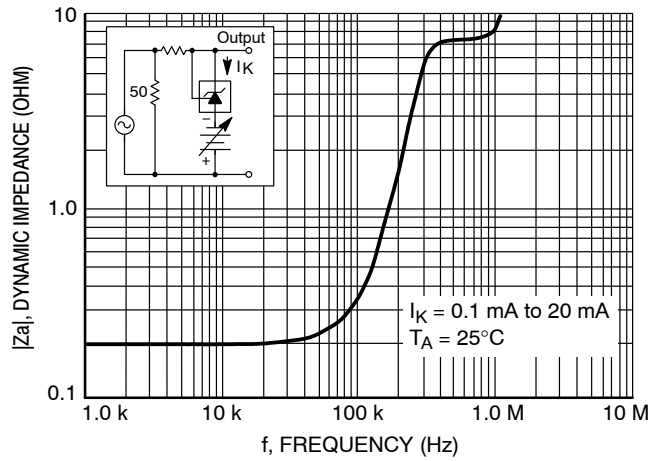

Figure 13. Dynamic Impedance versus Frequency

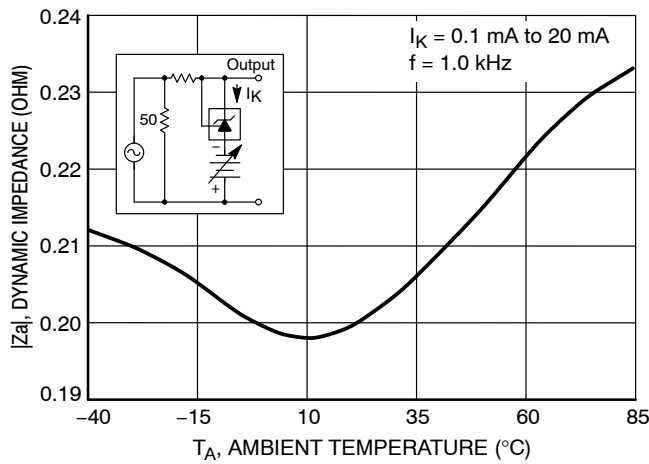

Figure 14. Dynamic Impedance versus Ambient Temperature

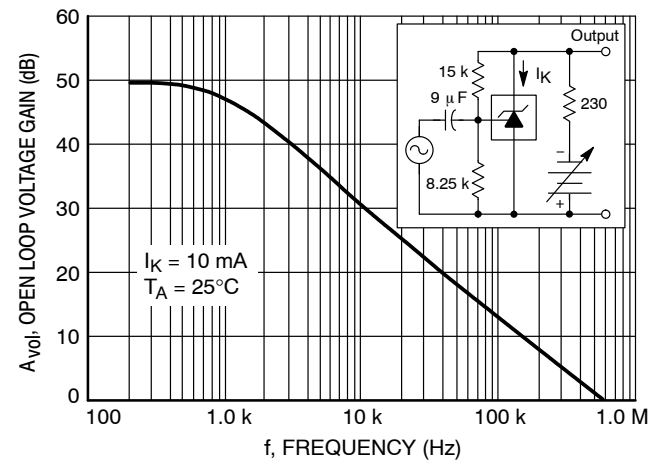

Figure 15. Open-Loop Voltage Gain versus Frequency

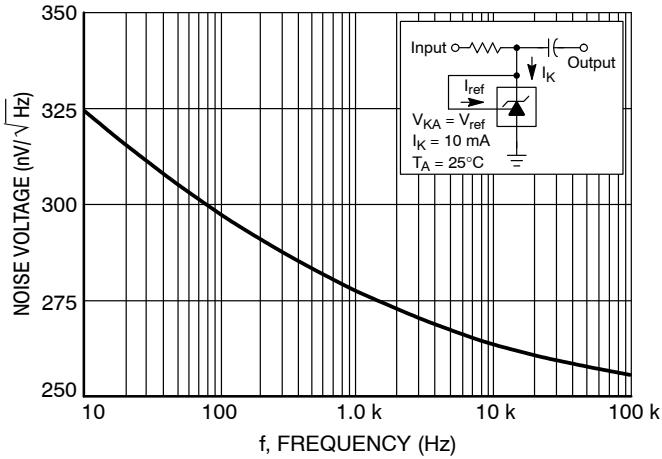

Figure 16. Spectral Noise Density

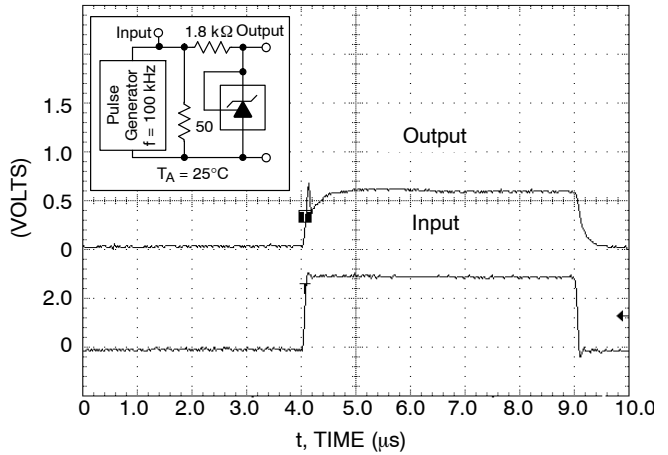

Figure 17. Pulse Response

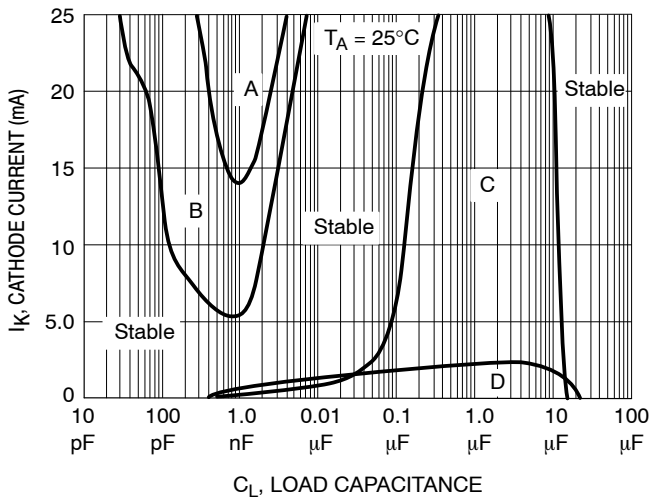
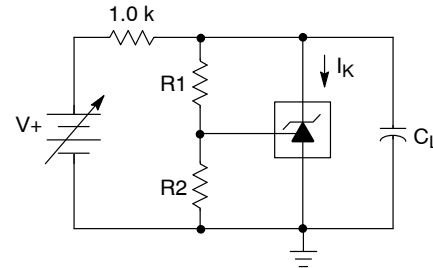

Figure 18. Stability Boundary Conditions



Unstable Regions	V _{KA} (V)	R1 (kΩ)	R2 (kΩ)
A, C	V _{ref}	0	∞
B, D	5.0	30.4	10

Figure 19. Test Circuit for Figure 18

Stability

Figures 18 and 19 show the stability boundaries and circuit configurations for the worst case conditions with the load capacitance mounted as close as possible to the device. The required load capacitance for stable operation can vary depending on the operating temperature and capacitor

equivalent series resistance (ESR). Ceramic or tantalum surface mount capacitors are recommended for both temperature and ESR. The application circuit stability should be verified over the anticipated operating current and temperature ranges.

TYPICAL APPLICATIONS

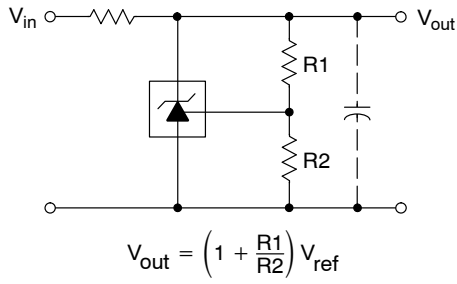

Figure 20. Shunt Regulator

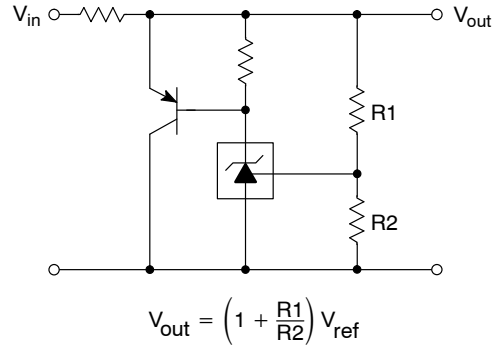

Figure 21. High Current Shunt Regulator

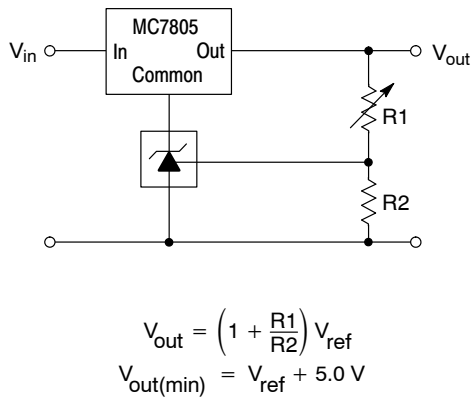

Figure 22. Output Control for a Three Terminal Fixed Regulator

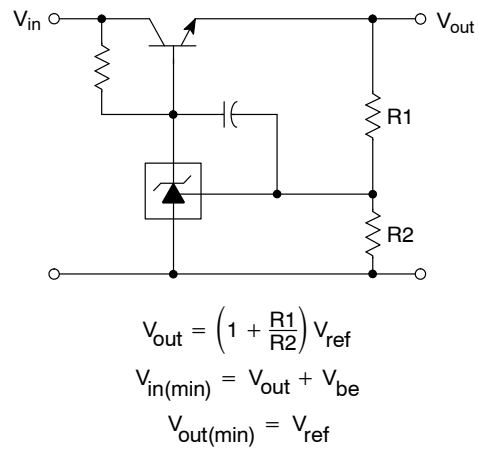

Figure 23. Series Pass Regulator

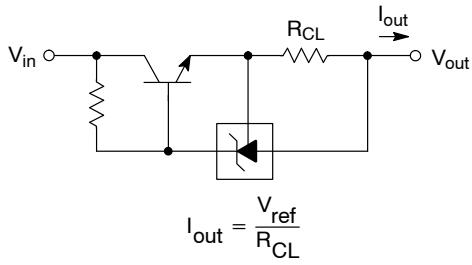

Figure 24. Constant Current Source

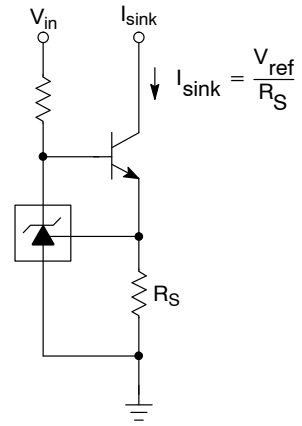

Figure 25. Constant Current Sink

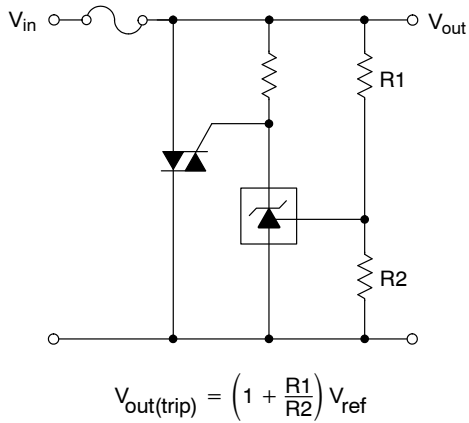

Figure 26. TRIAC Crowbar

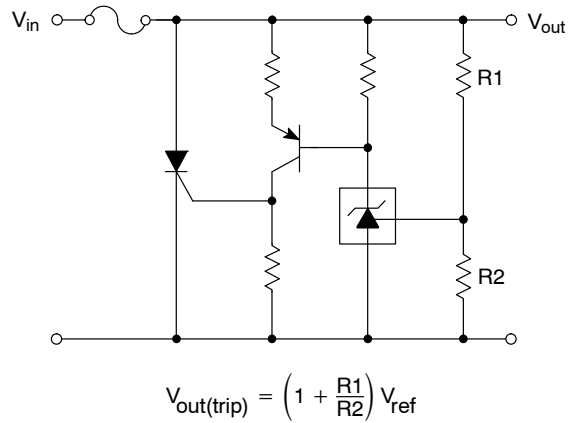
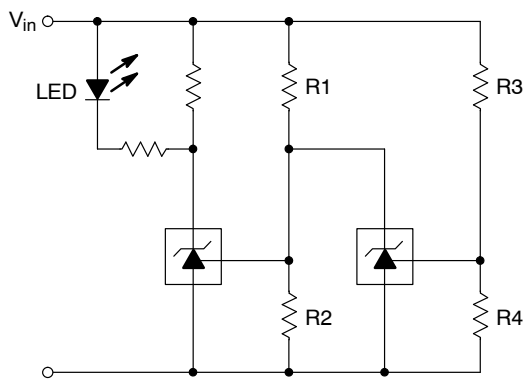

Figure 27. SCR Crowbar

TLV431, NCV431, SCV431



L.E.D. indicator is 'ON' when V_{in} is between the upper and lower limits,

$$\text{Lower limit} = \left(1 + \frac{R1}{R2}\right) V_{ref}$$

$$\text{Upper limit} = \left(1 + \frac{R3}{R4}\right) V_{ref}$$

Figure 28. Voltage Monitor

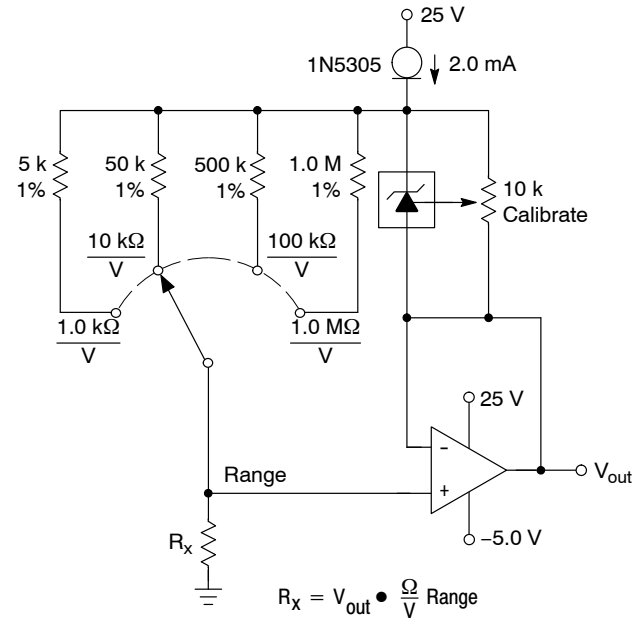

Figure 29. Linear Ohmmeter

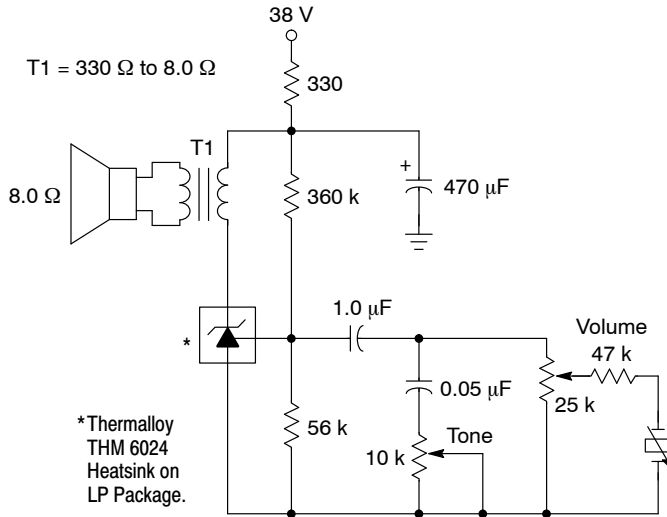

Figure 30. Simple 400 mW Phono Amplifier

TLV431, NCV431, SCV431

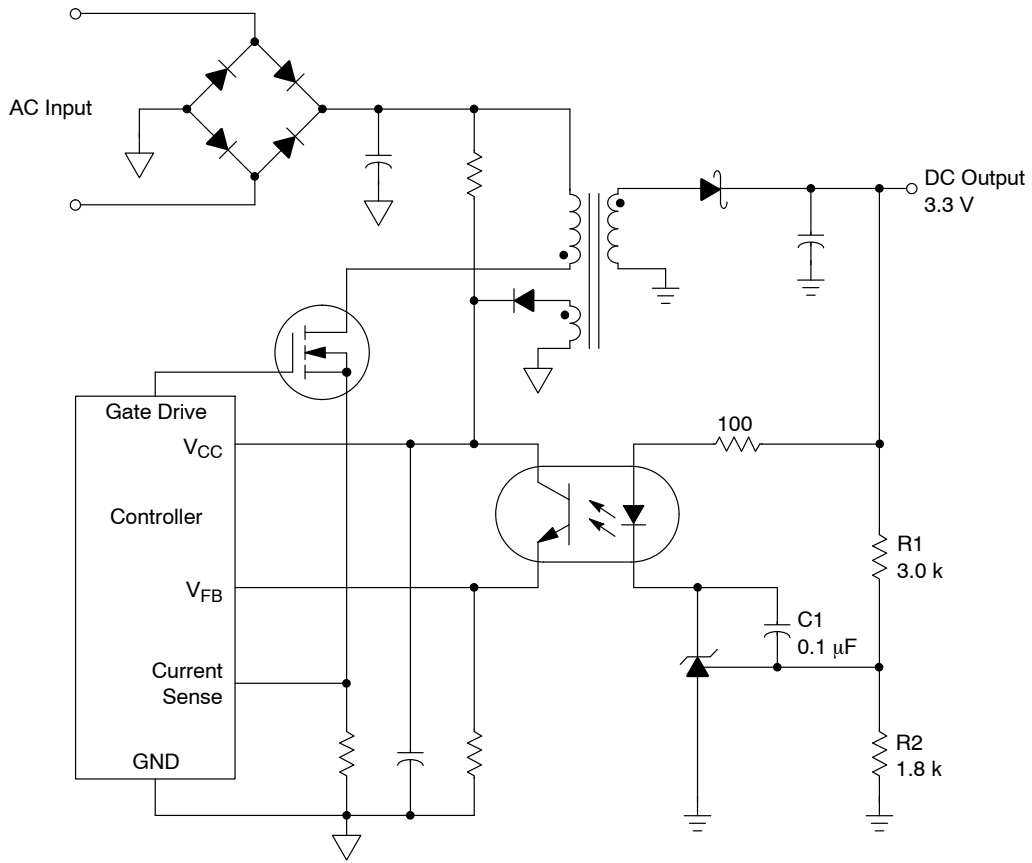
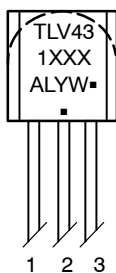

Figure 31. Isolated Output Line Powered Switching Power Supply

The above circuit shows the TLV431A/B/C as a compensated amplifier controlling the feedback loop of an isolated output line powered switching regulator. The output voltage is programmed to 3.3 V by the resistors values selected for R1 and R2. The minimum output voltage that can be programmed with this circuit is 2.64 V, and is limited by the sum of the reference voltage (1.24 V) and the forward drop of the optocoupler light emitting diode (1.4 V). Capacitor C1 provides loop compensation.

PIN CONNECTIONS AND DEVICE MARKING

TO-92



1. Reference
2. Anode
3. Cathode

TSOP-5

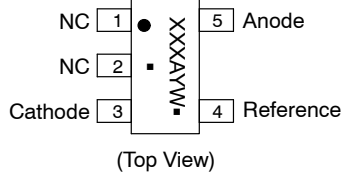

- XXX = Specific Device Code
 - A = Assembly Location
 - Y = Year
 - L = Wafer Lot
 - W = Work Week
 - = Pb-Free Package
- (Note: Microdot may be in either location)

SOT-23-3

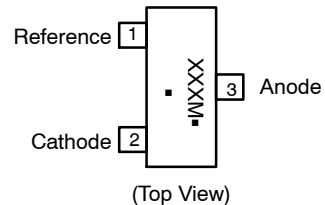

- XXX = Specific Device Code
 - M = Date Code
 - = Pb-Free Package
- (Note: Microdot may be in either location)

TLV431, NCV431, SCV431

ORDERING INFORMATION

Device	Device Code	Package	Shipping†
TLV431ALPG	ALP	TO-92-3 (Pb-Free)	6000 / Box
TLV431ALPRAG	ALP	TO-92-3 (Pb-Free)	2000 / Tape & Reel
TLV431ALPREG	ALP	TO-92-3 (Pb-Free)	2000 / Tape & Reel
TLV431ALPRMG	ALP	TO-92-3 (Pb-Free)	2000 / Ammo Pack
TLV431ALPRPG	ALP	TO-92-3 (Pb-Free)	2000 / Ammo Pack
TLV431ASNT1G	RAA	TSOP-5 (Pb-Free, Halide-Free)	3000 / Tape & Reel
TLV431ASN1T1G	RAF	SOT-23-3 (Pb-Free, Halide-Free)	3000 / Tape & Reel
TLV431BLPG	BLP	TO-92-3 (Pb-Free)	6000 / Box
TLV431BLPRAG	BLP	TO-92-3 (Pb-Free)	2000 / Tape & Reel
TLV431BLPREG	BLP	TO-92-3 (Pb-Free)	2000 / Tape & Reel
TLV431BLPRMG	BLP	TO-92-3 (Pb-Free)	2000 / Ammo Pack
TLV431BLPRPG	BLP	TO-92-3 (Pb-Free)	2000 / Ammo Pack
TLV431BSNT1G	RAH	TSOP-5 (Pb-Free, Halide-Free)	3000 / Tape & Reel
TLV431BSN1T1G	RAG	SOT-23-3 (Pb-Free, Halide-Free)	3000 / Tape & Reel
TLV431CSN1T1G	AAN	SOT-23-3 (Pb-Free, Halide-Free)	3000 / Tape & Reel
SCV431ASN1T1G*	RAE	SOT-23-3 (Pb-Free, Halide-Free)	3000 / Tape & Reel
SCV431BSN1T1G*	RAC	SOT-23-3 (Pb-Free, Halide-Free)	3000 / Tape & Reel
NCV431ASNT1G*	ACH	TSOP-5 (Pb-Free, Halide-Free)	3000 / Tape & Reel
NCV431BSNT1G*	AD6	TSOP-5 (Pb-Free, Halide-Free)	3000 / Tape & Reel

†For information on tape and reel specifications, including part orientation and tape sizes, please refer to our Tape and Reel Packaging Specifications Brochure, BRD8011/D.

*SCV, NCV Prefix for Automotive and Other Applications Requiring Unique Site and Control Change Requirements; AEC-Q100 Qualified and PPAP Capable.

TLV431, NCV431, SCV431

PACKAGE DIMENSIONS

TO-92 (TO-226)
CASE 29-11
ISSUE AN

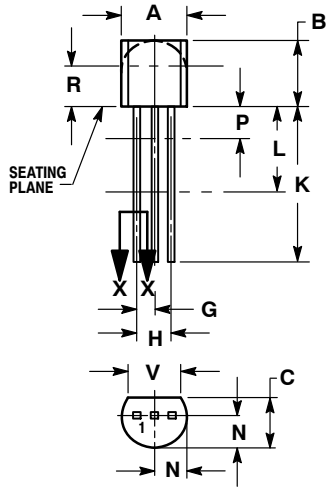

STRAIGHT LEAD
BULK PACK

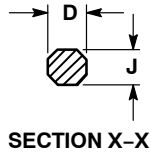

SECTION X-X

NOTES:

1. DIMENSIONING AND TOLERANCING PER ANSI Y14.5M, 1982.
2. CONTROLLING DIMENSION: INCH.
3. CONTOUR OF PACKAGE BEYOND DIMENSION R IS UNCONTROLLED.
4. LEAD DIMENSION IS UNCONTROLLED IN P AND BEYOND DIMENSION K MINIMUM.

DIM	INCHES		MILLIMETERS	
	MIN	MAX	MIN	MAX
A	0.175	0.205	4.45	5.20
B	0.170	0.210	4.32	5.33
C	0.125	0.165	3.18	4.19
D	0.016	0.021	0.407	0.533
G	0.045	0.055	1.15	1.39
H	0.095	0.105	2.42	2.66
J	0.015	0.020	0.39	0.50
K	0.500	---	12.70	---
L	0.250	---	6.35	---
N	0.080	0.105	2.04	2.66
P	---	0.100	---	2.54
R	0.115	---	2.93	---
V	0.135	---	3.43	---

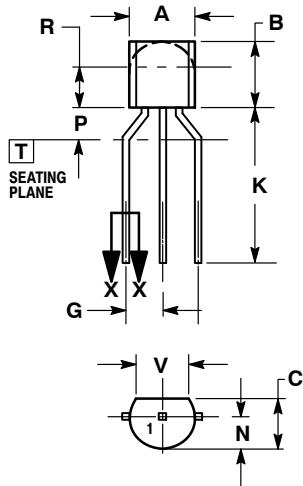

BENT LEAD
TAPE & REEL
AMMO PACK

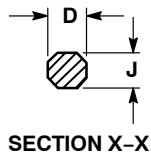

SECTION X-X

NOTES:

1. DIMENSIONING AND TOLERANCING PER ASME Y14.5M, 1994.
2. CONTROLLING DIMENSION: MILLIMETERS.
3. CONTOUR OF PACKAGE BEYOND DIMENSION R IS UNCONTROLLED.
4. LEAD DIMENSION IS UNCONTROLLED IN P AND BEYOND DIMENSION K MINIMUM.

DIM	MILLIMETERS	
	MIN	MAX
A	4.45	5.20
B	4.32	5.33
C	3.18	4.19
D	0.40	0.54
G	2.40	2.80
J	0.39	0.50
K	12.70	---
N	2.04	2.66
P	1.50	4.00
R	2.93	---
V	3.43	---

TLV431, NCV431, SCV431

PACKAGE DIMENSIONS

SOT-23 (TO-236)
CASE 318-08
ISSUE AS

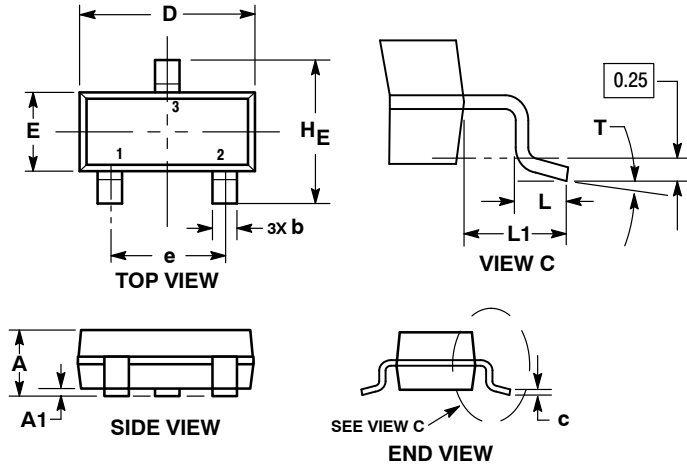

NOTES:

1. DIMENSIONING AND TOLERANCING PER ASME Y14.5M, 1994.
2. CONTROLLING DIMENSION: MILLIMETERS.
3. MAXIMUM LEAD THICKNESS INCLUDES LEAD FINISH. MINIMUM LEAD THICKNESS IS THE MINIMUM THICKNESS OF THE BASE MATERIAL.
4. DIMENSIONS D AND E DO NOT INCLUDE MOLD FLASH, PROTRUSIONS, OR GATE BURRS.

DIM	MILLIMETERS			INCHES		
	MIN	NOM	MAX	MIN	NOM	MAX
A	0.89	1.00	1.11	0.035	0.039	0.044
A1	0.01	0.06	0.10	0.000	0.002	0.004
b	0.37	0.44	0.50	0.015	0.017	0.020
c	0.08	0.14	0.20	0.003	0.006	0.008
D	2.80	2.90	3.04	0.110	0.114	0.120
E	1.20	1.30	1.40	0.047	0.051	0.055
e	1.78	1.90	2.04	0.070	0.075	0.080
L	0.30	0.43	0.55	0.012	0.017	0.022
L1	0.35	0.54	0.69	0.014	0.021	0.027
HE	2.10	2.40	2.64	0.083	0.094	0.104
T	0°	---	10°	0°	---	10°

RECOMMENDED SOLDERING FOOTPRINT*

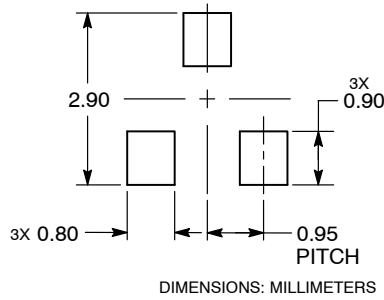

*For additional information on our Pb-Free strategy and soldering details, please download the ON Semiconductor Soldering and Mounting Techniques Reference Manual, SOLDERRM/D.

TLV431, NCV431, SCV431

PACKAGE DIMENSIONS

TSOP-5 SN SUFFIX CASE 483 ISSUE M

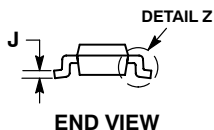
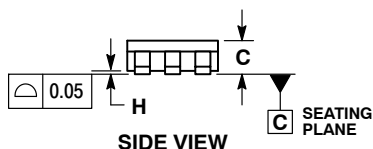
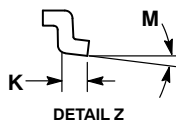
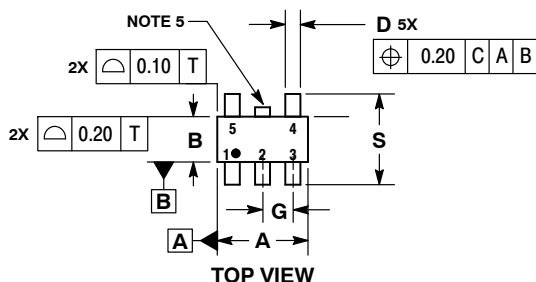

NOTES:

1. DIMENSIONING AND TOLERANCING PER ASME Y14.5M, 1994.
2. CONTROLLING DIMENSION: MILLIMETERS.
3. MAXIMUM LEAD THICKNESS INCLUDES LEAD FINISH THICKNESS. MINIMUM LEAD THICKNESS IS THE MINIMUM THICKNESS OF BASE MATERIAL.
4. DIMENSIONS A AND B DO NOT INCLUDE MOLD FLASH, PROTRUSIONS, OR GATE BURRS. MOLD FLASH, PROTRUSIONS, OR GATE BURRS SHALL NOT EXCEED 0.15 PER SIDE. DIMENSION A.
5. OPTIONAL CONSTRUCTION: AN ADDITIONAL TRIMMED LEAD IS ALLOWED IN THIS LOCATION. TRIMMED LEAD NOT TO EXTEND MORE THAN 0.2 FROM BODY.

DIM	MILLIMETERS	
	MIN	MAX
A	2.85	3.15
B	1.35	1.65
C	0.90	1.10
D	0.25	0.50
G	0.95 BSC	
H	0.01	0.10
J	0.10	0.26
K	0.20	0.60
M	0°	10°
S	2.50	3.00

SOLDERING FOOTPRINT*

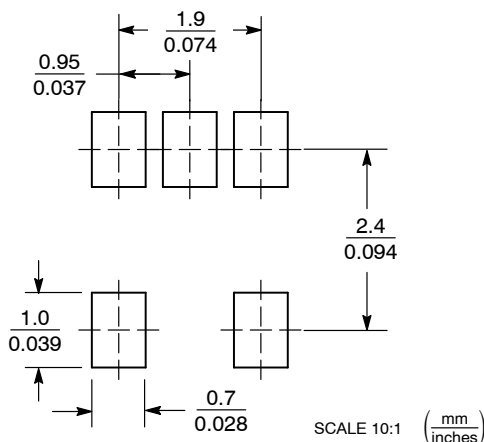

*For additional information on our Pb-Free strategy and soldering details, please download the ON Semiconductor Soldering and Mounting Techniques Reference Manual, SOLDERRM/D.

ON Semiconductor and are trademarks of Semiconductor Components Industries, LLC dba ON Semiconductor or its subsidiaries in the United States and/or other countries. ON Semiconductor owns the rights to a number of patents, trademarks, copyrights, trade secrets, and other intellectual property. A listing of ON Semiconductor's product/patent coverage may be accessed at www.onsemi.com/site/pdf/Patent-Marking.pdf. ON Semiconductor reserves the right to make changes without further notice to any products herein. ON Semiconductor makes no warranty, representation or guarantee regarding the suitability of its products for any particular purpose, nor does ON Semiconductor assume any liability arising out of the application or use of any product or circuit, and specifically disclaims any and all liability, including without limitation special, consequential or incidental damages. Buyer is responsible for its products and applications using ON Semiconductor products, including compliance with all laws, regulations and safety requirements or standards, regardless of any support or applications information provided by ON Semiconductor. "Typical" parameters which may be provided in ON Semiconductor data sheets and/or specifications can and do vary in different applications and actual performance may vary over time. All operating parameters, including "Typicals" must be validated for each customer application by customer's technical experts. ON Semiconductor does not convey any license under its patent rights nor the rights of others. ON Semiconductor products are not designed, intended, or authorized for use as a critical component in life support systems or any FDA Class 3 medical devices or medical devices with a same or similar classification in a foreign jurisdiction or any devices intended for implantation in the human body. Should Buyer purchase or use ON Semiconductor products for any such unintended or unauthorized application, Buyer shall indemnify and hold ON Semiconductor and its officers, employees, subsidiaries, affiliates, and distributors harmless against all claims, costs, damages, and expenses, and reasonable attorney fees arising out of, directly or indirectly, any claim of personal injury or death associated with such unintended or unauthorized use, even if such claim alleges that ON Semiconductor was negligent regarding the design or manufacture of the part. ON Semiconductor is an Equal Opportunity/Affirmative Action Employer. This literature is subject to all applicable copyright laws and is not for resale in any manner.

PUBLICATION ORDERING INFORMATION

LITERATURE FULFILLMENT:

Literature Distribution Center for ON Semiconductor
19521 E. 32nd Pkwy, Aurora, Colorado 80011 USA
Phone: 303-675-2175 or 800-344-3860 Toll Free USA/Canada
Fax: 303-675-2176 or 800-344-3867 Toll Free USA/Canada
Email: orderlit@onsemi.com

N. American Technical Support: 800-282-9855 Toll Free
USA/Canada
Europe, Middle East and Africa Technical Support:
Phone: 421 33 790 2910



ON Semiconductor Website: www.onsemi.com

Order Literature: <http://www.onsemi.com/orderlit>

For additional information, please contact your local Sales Representative

Looking for pricing, stock, or lifecycle information?

Click below to explore more details on WIN SOURCE:

-  [View TLV431BLPG on WIN SOURCE](#)
-  [ON Semiconductor Information](#)

Optimize Your Supply Chain with WIN SOURCE Solutions

-  Global Sourcing Solution
-  Obsolete Management
-  Cost Control Management
-  Shortage Management
-  Alternative Solution
-  Excess Inventory Management