



**THE DATASHEET OF  
PI3HDMI412-ABE**





PI3HDMI412-A

4-Differential Channel, 2:1 Mux/DeMux, DVI/HDMI Compliant Signal Switch based on TMDS Signaling Standard

Features

- 4-Differential Channel 2:1 Mux/DeMux
- TMDS Signaling
- Data Rate: 1.65Gbps
- Crosstalk: -25dB@825MHz
- Switching speed: 4ns
- Isolation: -30dB@825MHz
- ESD: Data bits @ 8kV HBM, select bit @ 2 kV HBM
- Near-Zero Prop Delay: 250ps max.
- Low bit-to-bit skew
- Hot insertion capable
- Enable/Disable Time: 9ns
- Bidirectional
- Packaging (Pb-free & Green):
  - 42-pin TQFN (ZH)
  - 48-pin BQSOP (B)

Description

Pericom Semiconductor's PI3HDMI series of switch circuits are targeted for high-resolution video networks that are based on DVI/HDMI standards, and TMDS signal processing. The PI3HDMI412-A is a 8- to 4-Channel Mux/DeMux Switch. The device multiplexes differential signals to one of two corresponding outputs. The switch is bidirectional and offers little or no attenuation of the high-speed signals at the outputs. It is designed for low bit-to-bit skew and high channel-to-channel noise isolation.

The maximum DVI/HDMI data rate of 1.65Gbps provides the resolution required by the next generation HDTV and PC graphics. Three differential channels are used for data (video signals for DVI or audio/video signals for HDMI), and one differential channel is used for Clock for decoding the TMDS signals at the outputs.

Because of its passive bidirectional feature, this switch can be used either at the video drivers side or at the receiver side. For PC graphics applications, the device sits at the drivers side to switch between multiple display units such as PC LCD monitor, projector, TV, etc. For consumer video applications, the device sits at the receiver end to switch between the source components such as DVD, D-VHS, STB, etc.

Block Diagram

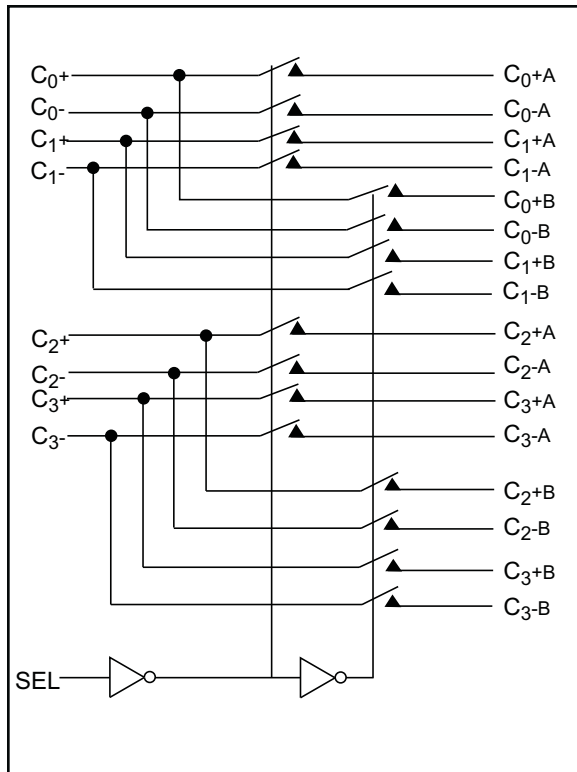

Pin Descriptions (Top View)

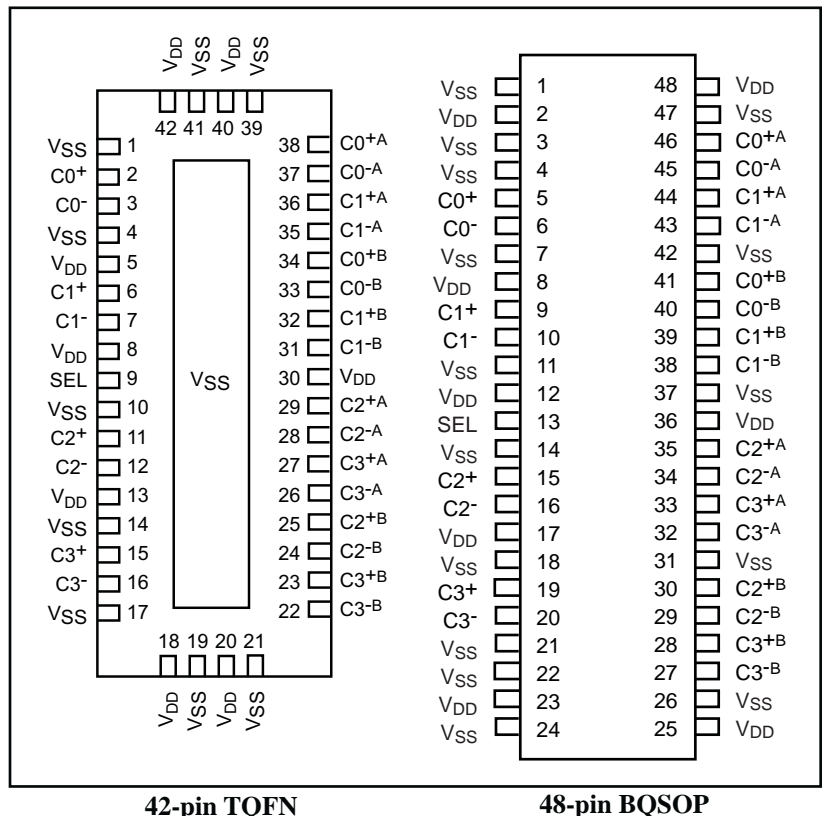



**Truth Table**

Function	SEL
N to N <sup>A</sup>	L
N to N <sup>B</sup>	H

**Pin Description**

Pin #	Pin Name	Description
5, 8, 13, 18, 20, 30, 40, 42	V <sub>DD</sub>	+ Power supply 3.30
1, 4, 10, 14, 17, 19, 21, 39, 41	V <sub>SS</sub>	- Power supply
9	SEL	Select pin, see truth table
2, 3, 6, 7, 11, 12, 15, 16, 31-38, 22-29	CX <sup>tx</sup>	Data + Clk bits for TMDS signal

**Maximum Ratings**

(Above which useful life may be impaired. For user guidelines, not tested.)

Storage Temperature.....	-65°C to +150°C
Supply Voltage to V <sub>SS</sub> Potential.....	-0.5V to +2.5V
DC Input Voltage .....	V <sub>SS</sub> to V <sub>DD</sub>
DC Output Current.....	120mA
Power Dissipation.....	0.5W

**Note:**

Stresses greater than those listed under MAXIMUM RATINGS may cause permanent damage to the device. This is a stress rating only and functional operation of the device at these or any other conditions above those indicated in the operational sections of this specification is not implied. Exposure to absolute maximum rating conditions for extended periods may affect reliability.

**DC Power Supply Characteristics**

Parameter	Description	Min.	Max.	Units
V <sub>DD</sub>	Positive Power Supply	3.0	3.6	V
V <sub>SS</sub>	Negative Power Supply	1.5	1.6	V

**DC Electrical Characteristics for Switching over Operating Range** (T<sub>A</sub> = -40°C to +85°C)

Parameter	Description	Test Conditions	Min.	Typ <sup>(2)</sup>	Max.	Units
V <sub>IH</sub> <sup>(3)</sup>	Input HIGH Voltage	Guaranteed HIGH level	0.65(V <sub>DD</sub> -V <sub>SS</sub> )+V <sub>SS</sub>			V
V <sub>IL</sub> <sup>(3)</sup>	Input LOW Voltage	Guaranteed LOW level	-0.5+V <sub>SS</sub>		0.35(V <sub>DD</sub> -V <sub>SS</sub> )+V <sub>SS</sub>	
V <sub>IK</sub>	Clamp Diode Voltage	V <sub>DD</sub> =Max., I <sub>IN</sub> =-18mA		-0.7+V <sub>SS</sub>	-1.2+V <sub>SS</sub>	
I <sub>IH</sub>	Input HIGH Current	V <sub>DD</sub> =Max., V <sub>IN</sub> =V <sub>DD</sub>			±5	µA
I <sub>IL</sub>	Input LOW Current	V <sub>DD</sub> =Max., V <sub>IN</sub> =V <sub>SS</sub>			±5	

**Notes:**

- For Max. or Min. conditions, use appropriate value specified under Electrical Characteristics for the applicable device type.
- Typical values are at T<sub>A</sub> = 25°C ambient and maximum loading.
- V<sub>IH</sub> + V<sub>IL</sub> are for SEL input only.

**Power Supply Characteristics**

Parameters	Description	Test Conditions <sup>(1)</sup>	Min.	Typ. <sup>(2)</sup>	Max.	Units
I <sub>CC</sub>	Quiescent Power Supply Current	V <sub>DD</sub> = Max., V <sub>IN</sub> = V <sub>DD</sub> or V <sub>SS</sub>		200		μA

**Notes:**

1. For Max. or Min. conditions, use appropriate value specified under Electrical Characteristics for the applicable device type.
2. Typical values are at T<sub>A</sub> = 25°C ambient and maximum loading.

**Dynamic Electrical Characteristics Over the Operating Range (T<sub>A</sub> = -40° to +85°C)**

Parameter	Description	Test Conditions	Min.	Typ. <sup>(2)</sup>	Max.	Units
X <sub>TALK</sub>	Crosstalk	See Fig. 1 for Measurement Setup, f = 825 MHz		-25		dB
O <sub>IRR</sub>	OFF Isolation	See Fig. 2 for Measurement Setup, f = 825 MHz		-30		
DR	Data Rate				4.0	Gbps

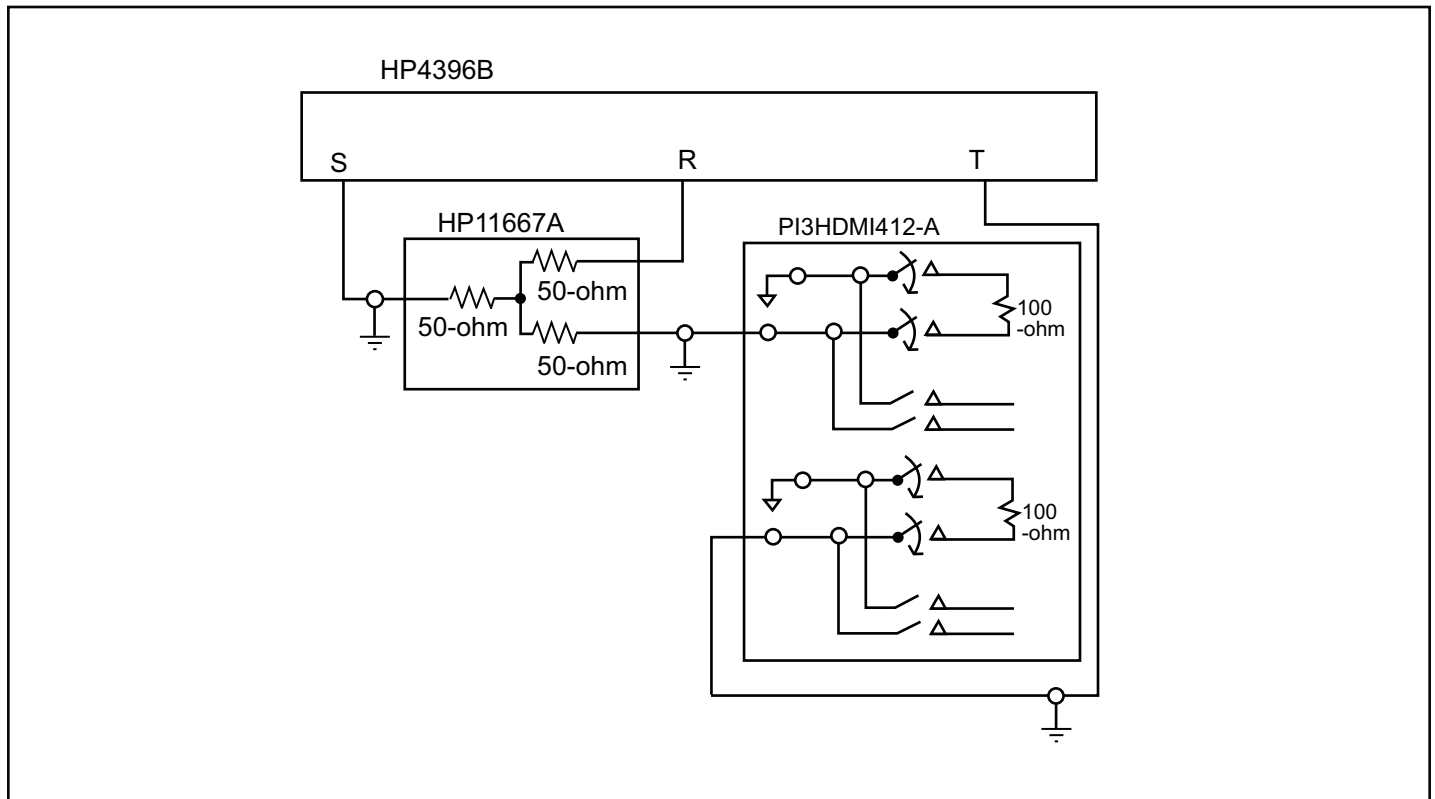

**Fig 1. Crosstalk Setup**

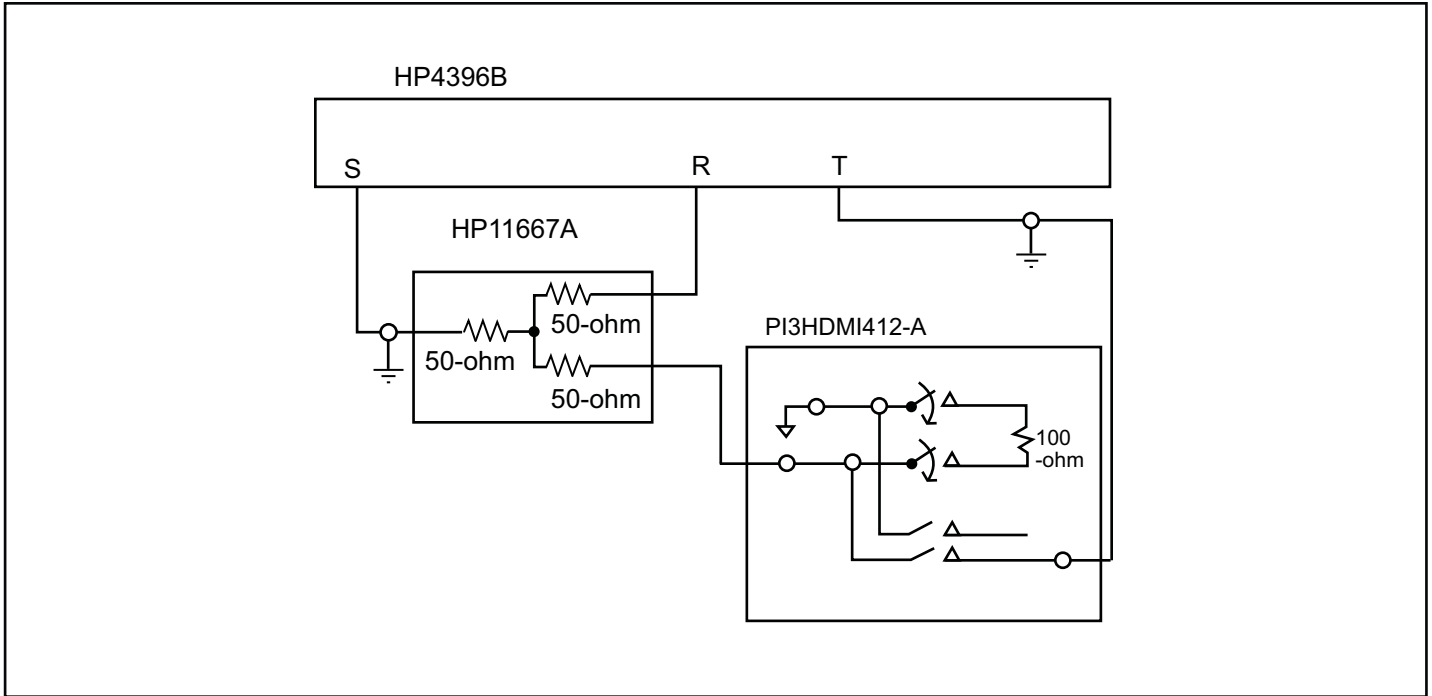

Fig 2. Off-isolation setup

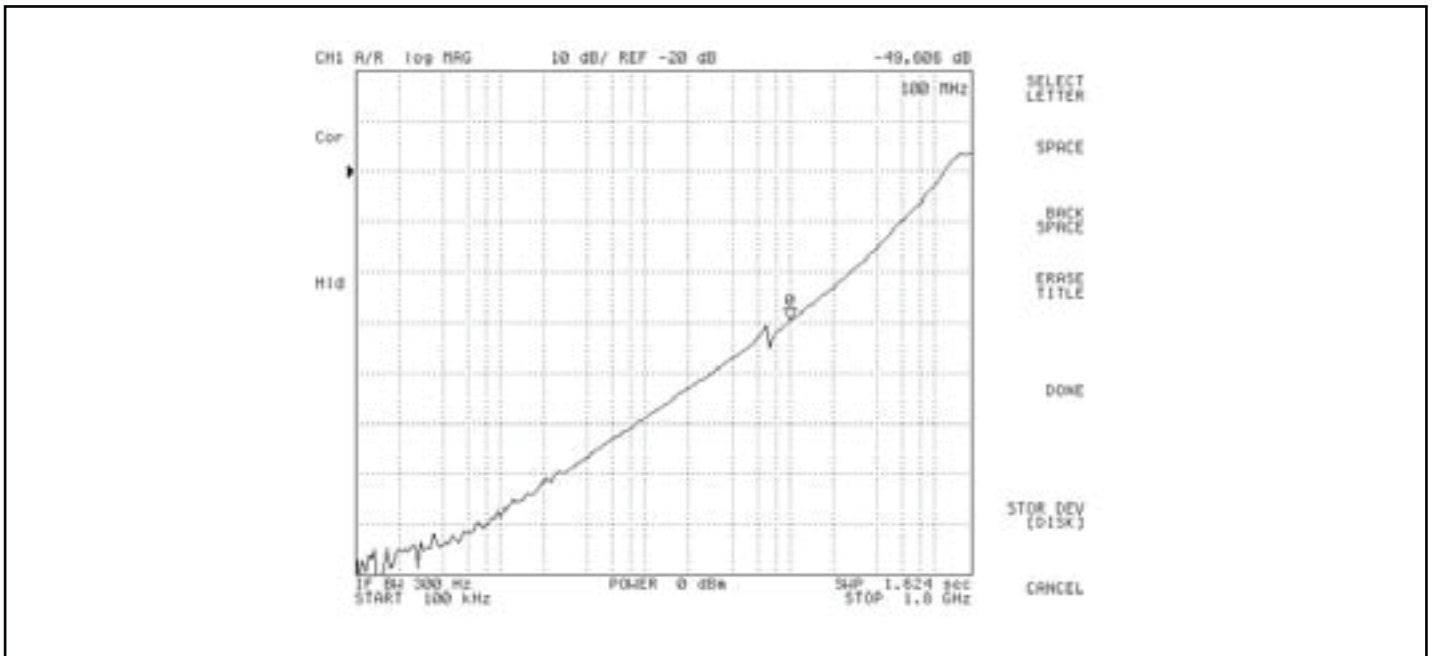

Fig 3. Crosstalk

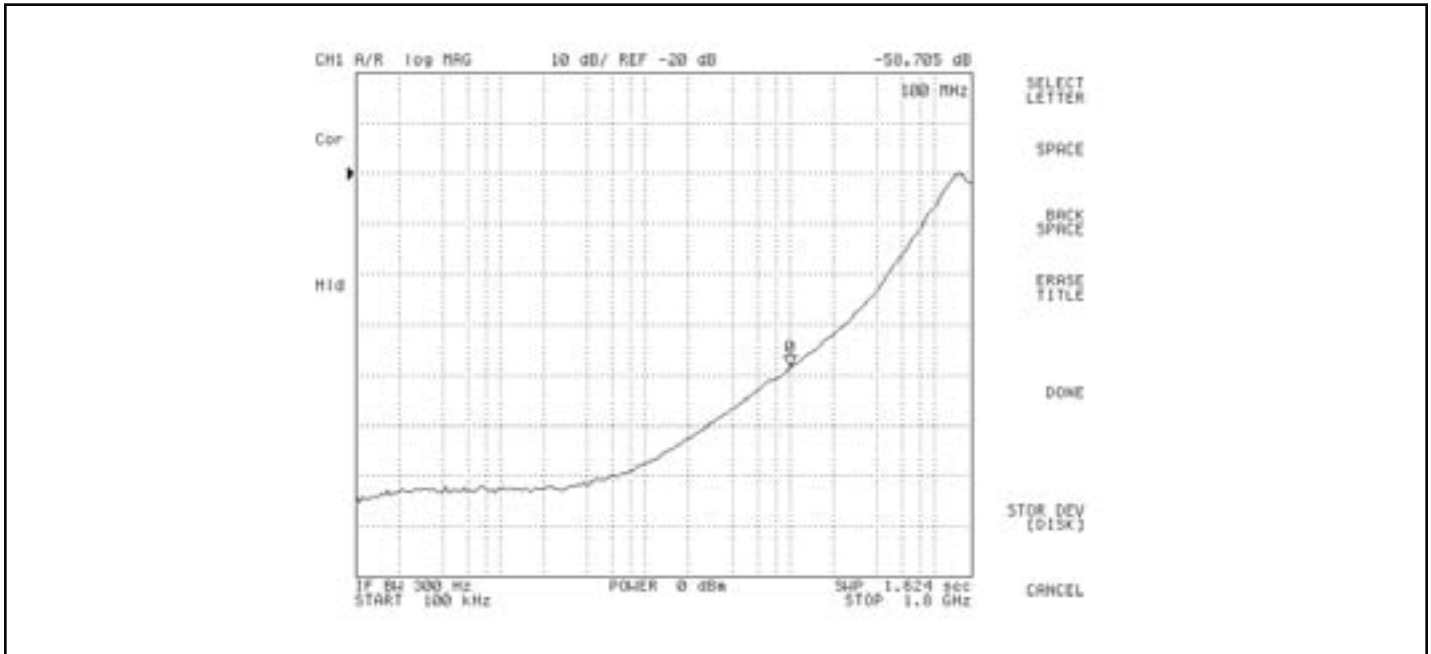

Fig 4. Off Isolation

**Switching Characteristics** ( $T_A = -40^\circ$  to  $+85^\circ\text{C}$ ,  $V_{SS}=0\text{V}$ ,  $V_{DD}=1.8\text{V} \pm 10\%$ )

Parameter	Description	Min.	Typ. <sup>(2)</sup>	Max.	Units
t <sub>PZH</sub> , t <sub>PZL</sub>	Line Enable Time - SEL to A <sub>N</sub> , B <sub>N</sub>	0.5		8.0	ns
t <sub>PHZ</sub> , t <sub>PLZ</sub>	Line Disable Time - SEL to A <sub>N</sub> , B <sub>N</sub>	0.5		4.0	

**Notes:**

1. For measurement setup, please see “Test Circuit For Electrical Characteristic” on page 6, and “Switching waveforms” on page 7

**Test Circuit for Electrical Characteristics<sup>(1)</sup>**

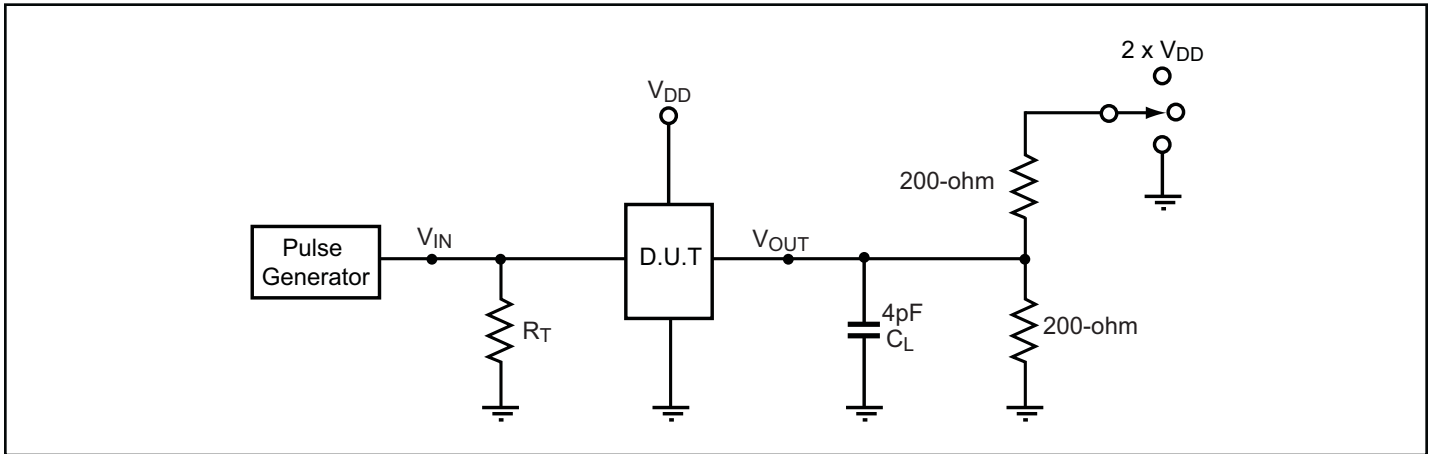

**Notes:**

1.  $C_L$  = Load capacitance: includes jig and probe capacitance.
2.  $R_T$  = Termination resistance: should be equal to  $Z_{OUT}$  of the Pulse Generator
3. Waveform 1 is for an output with internal conditions such that the output is low except when disabled by the output control.  
Waveform 2 is for an output with internal conditions such that the output is high except when disabled by the output control.
4. All input impulses are supplied by generators having the following characteristics:  $PRR \leq \text{MHz}$ ,  $Z_O = 50\Omega$ ,  $t_R \leq 2.5\text{ns}$ ,  $t_F \leq 2.5\text{ns}$ .
5. The outputs are measured one at a time with one transition per measurement.

**Switch Positions**

Test	Switch
$t_{PLZ}$ , $t_{PZL}$ (output on B-side)	$2 \times (V_{DD} - V_{SS})$
$t_{PHZ}$ , $t_{PZH}$ (output on B-side)	$V_{SS}$
Prop Delay	Open

**Test Circuit for Dynamic Electrical Characteristics**

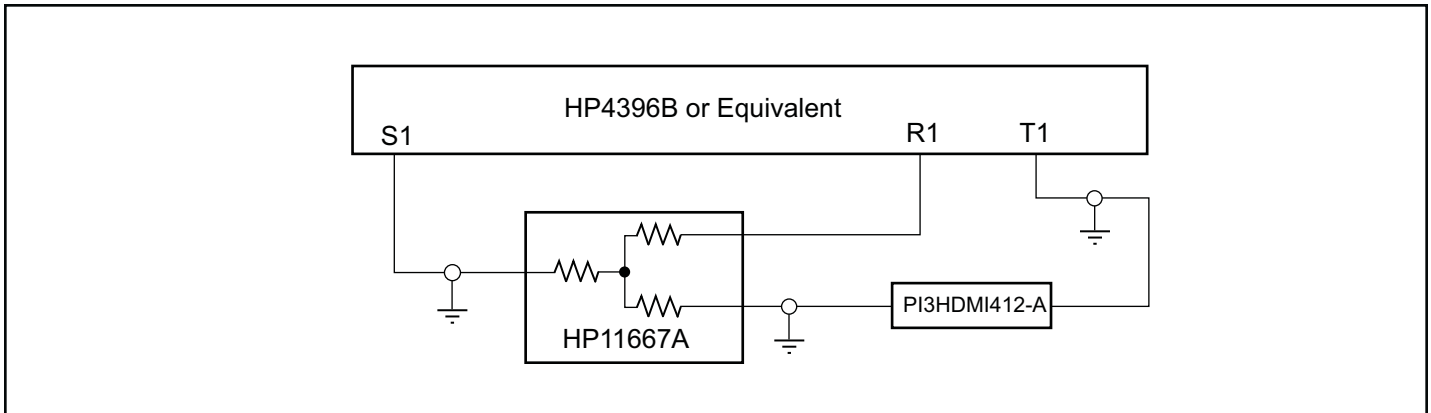

Switching Waveforms

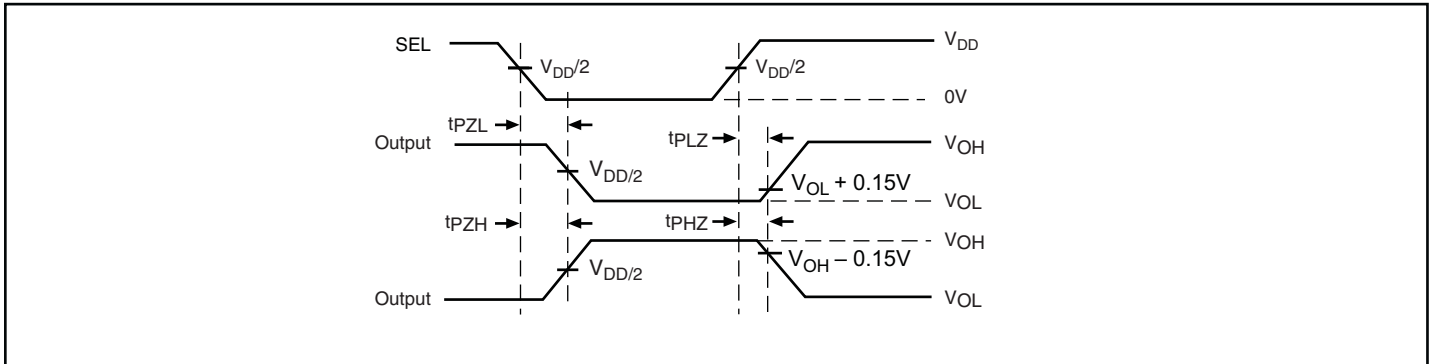

Voltage Waveforms Enable and Disable Times

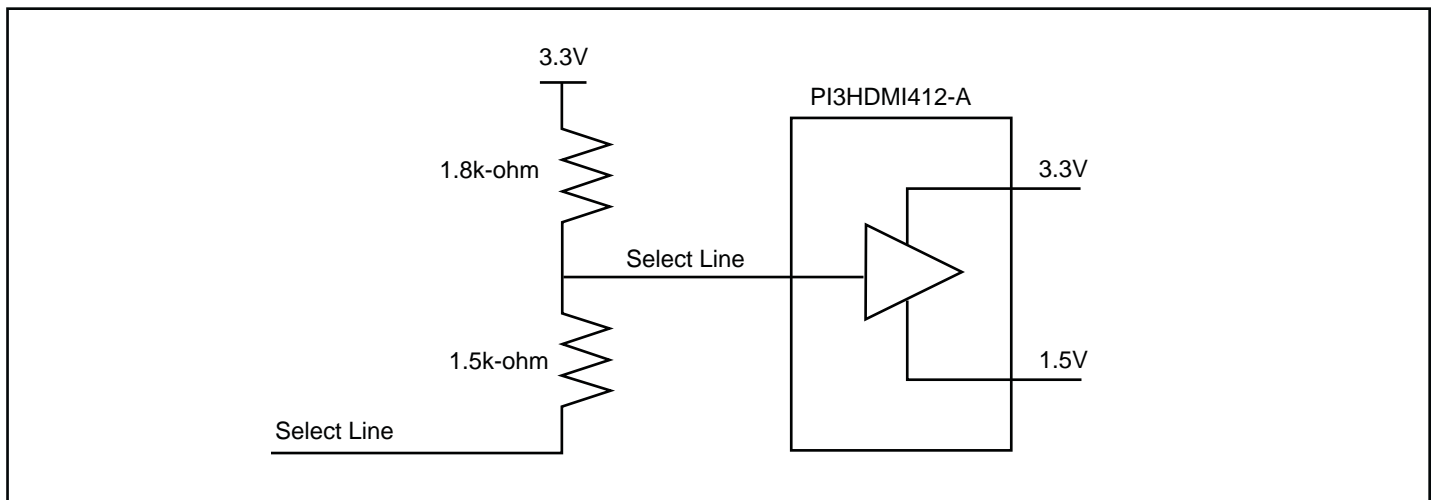

Example of a circuit that needs to be connected to the select lines of our device:

Application Test Results

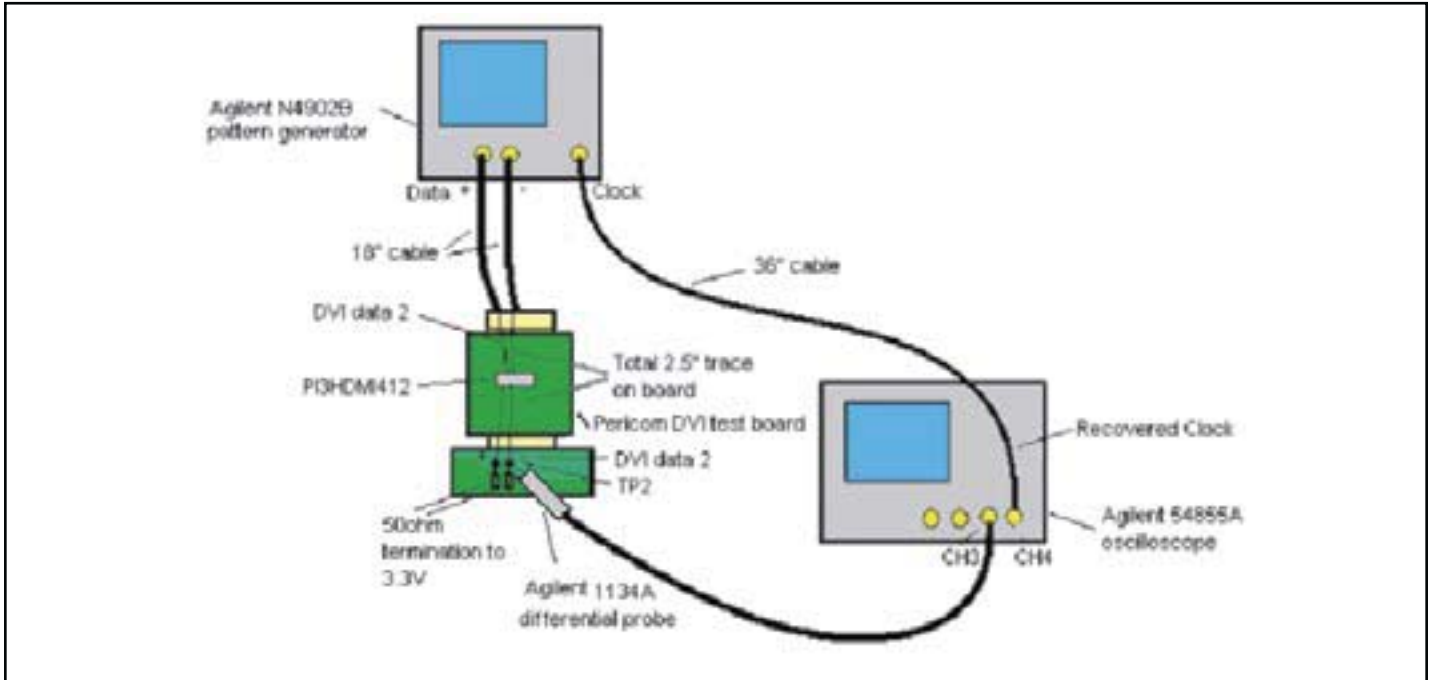

Figure 1. TMDS TP2 Tx eye compliance test setup

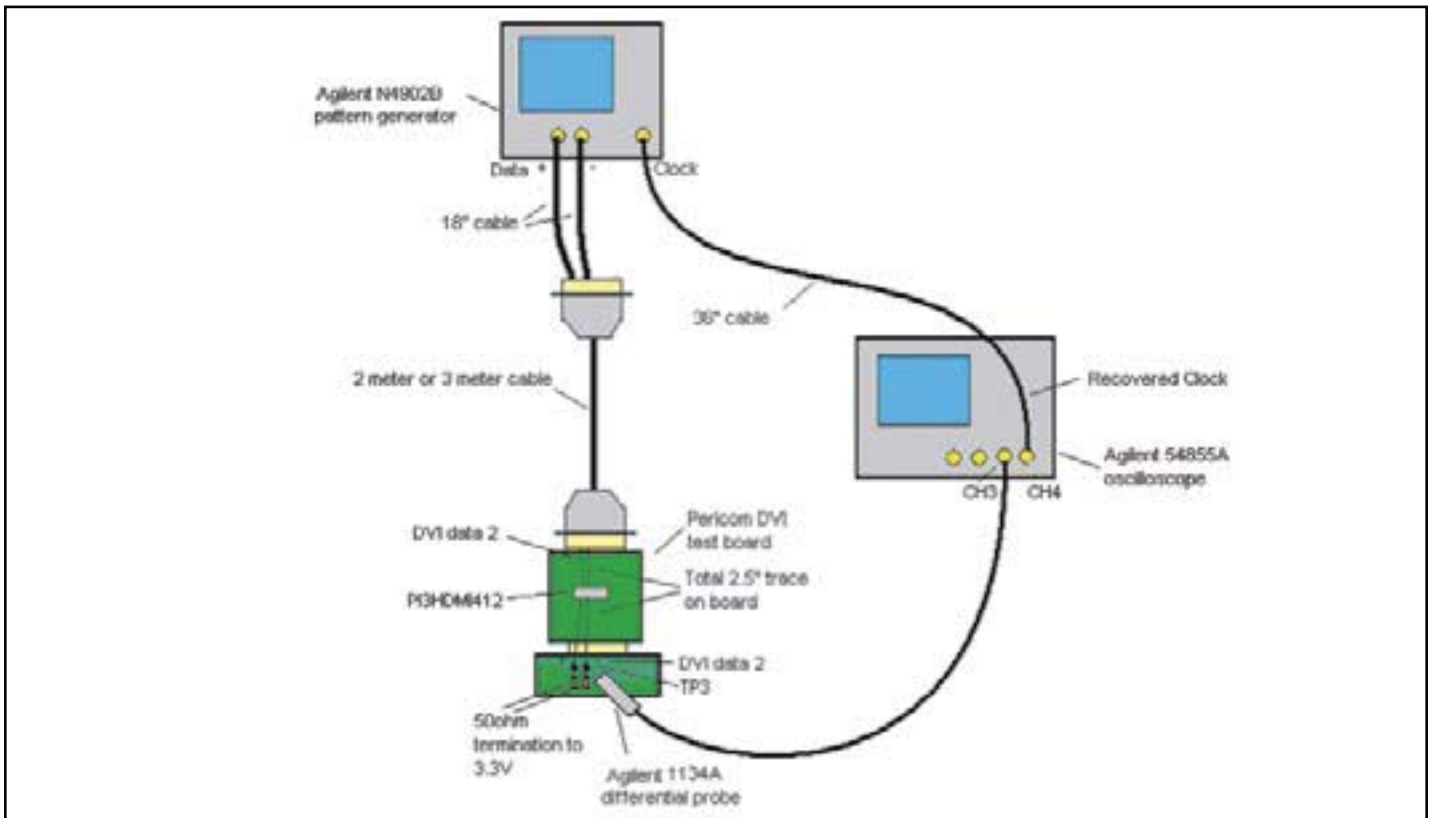

Figure 2. TMDS TP3 Rx "switch at receiver" eye compliance test setup

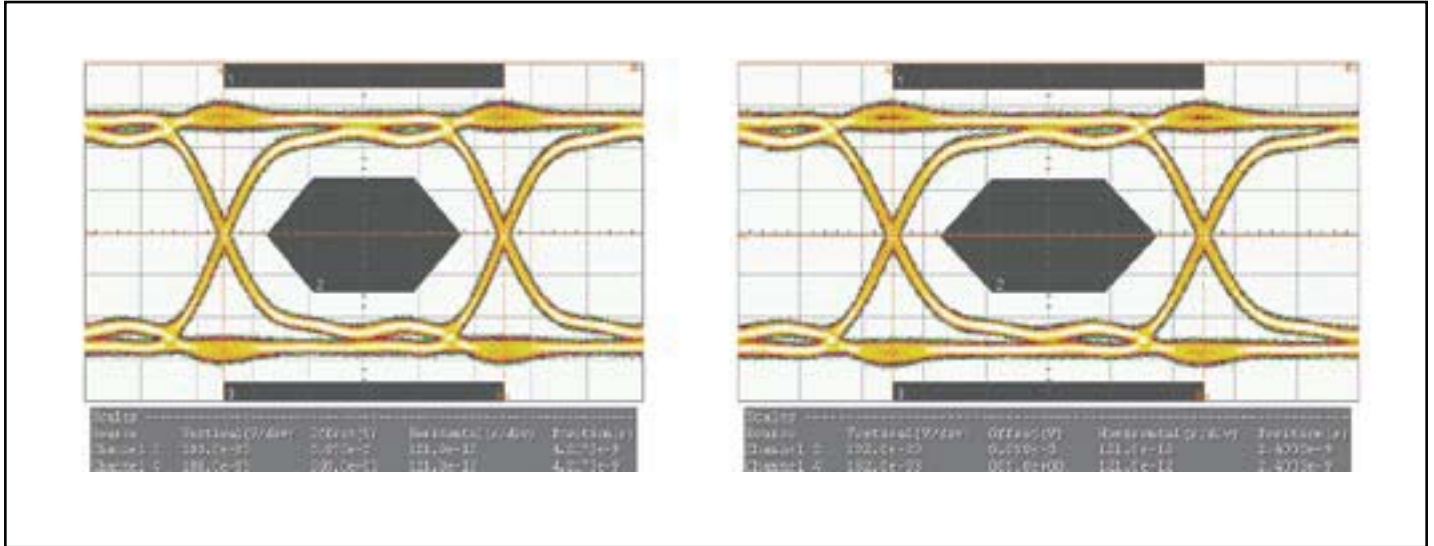

Figure 3. TP2 (Tx) eye-measurements (left is with switch, right is without switch), refer to figure 1 for the test set up

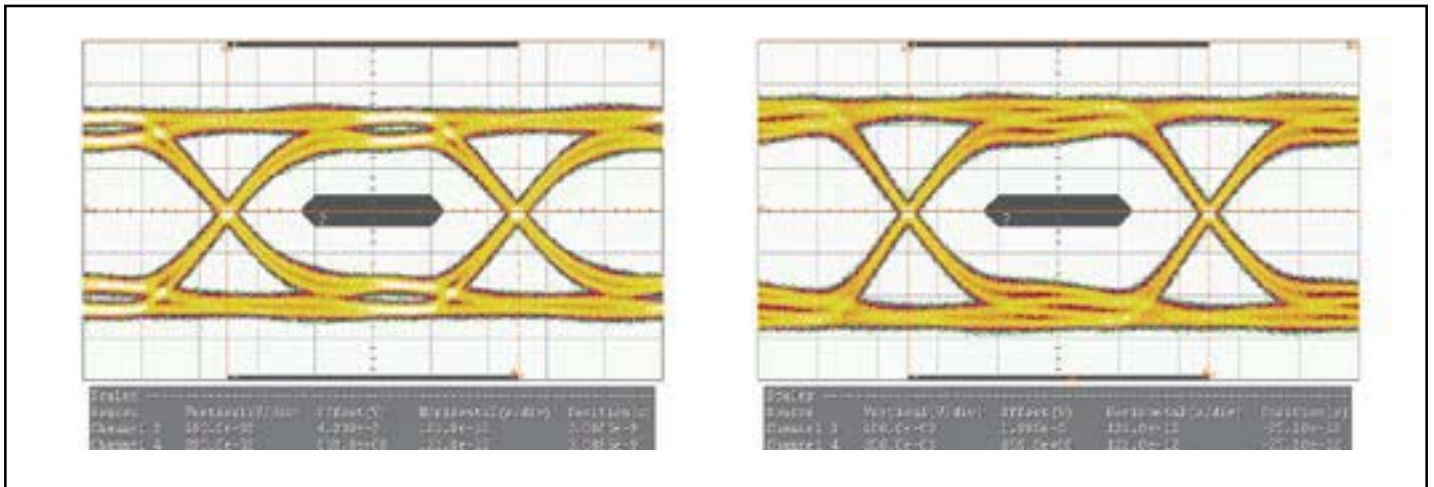
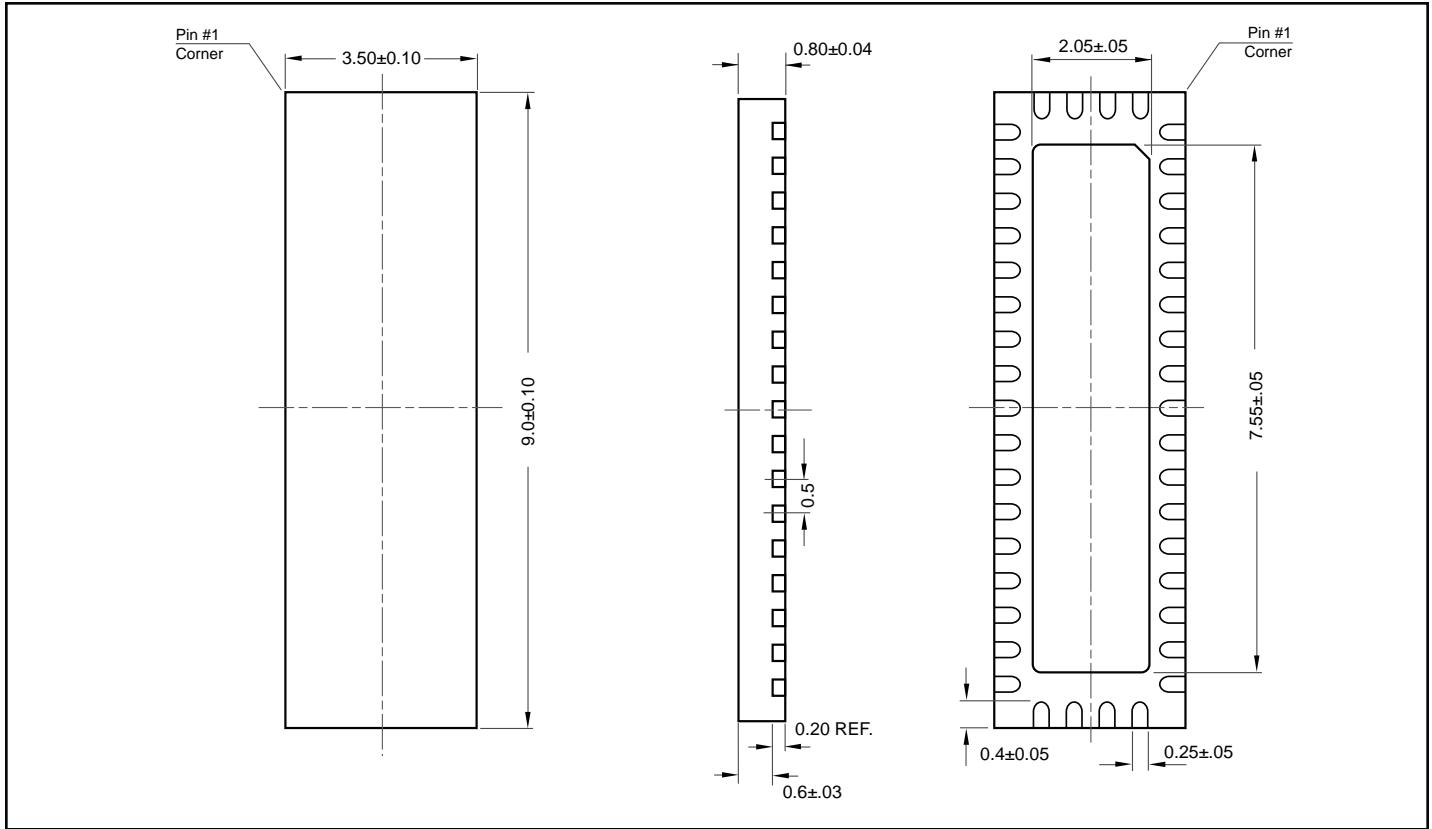
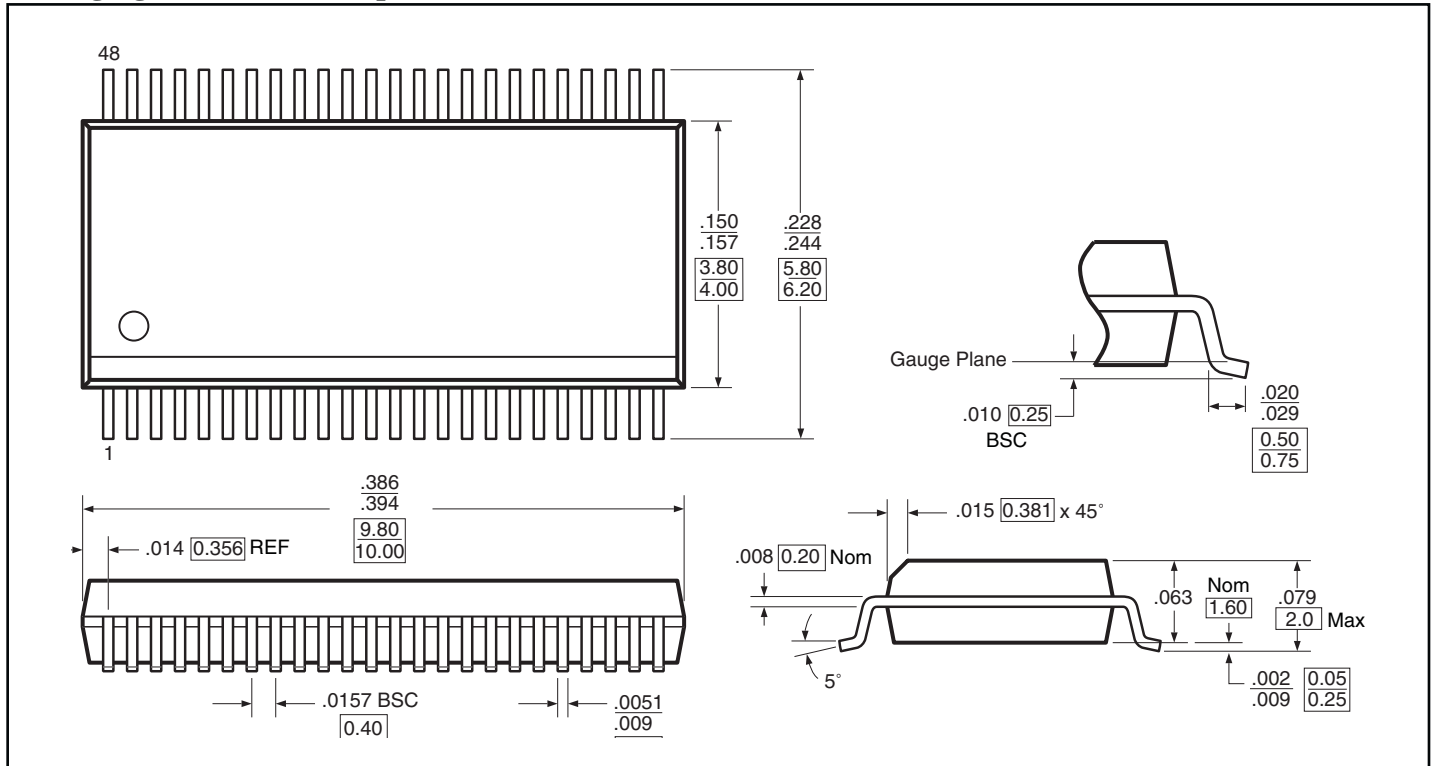

Figure 4. TP3 (Rx) - "Switch at receiver side" with 2-meter cable eye-measurements (left is with switch, right is without switch), refer to figure 2 for the test set up.

**Packaging Mechanical: 42-pin TQFN (ZH)**





**Packaging Mechanical: 48-pin BQSOP (B)**



## Looking for pricing, stock, or lifecycle information?

Click below to explore more details on WIN SOURCE:

-  [View PI3HDMI412-ABE on WIN SOURCE](#)
-  [Diodes Incorporated Information](#)

## Optimize Your Supply Chain with WIN SOURCE Solutions

-  Global Sourcing Solution
-  Obsolete Management
-  Cost Control Management
-  Shortage Management
-  Alternative Solution
-  Excess Inventory Management