



**THE DATASHEET OF
CALVC164245IDGGREP**



FEATURES

- Controlled Baseline
 - One Assembly/Test Site, One Fabrication Site
- Enhanced Diminishing Manufacturing Sources (DMS) Support
- Enhanced Product-Change Notification
- Qualification Pedigree⁽¹⁾
- Member of the Texas Instruments Widebus™ Family
- Max t_{pd} of 5.8 ns at 3.3 V
- ± 24 -mA Output Drive at 3.3 V
- Control Inputs V_{IH}/V_{IL} Levels Are Referenced to V_{CCA} Voltage
- Latch-Up Performance Exceeds 250 mA Per JESD 17

(1) Component qualification in accordance with JEDEC and industry standards to ensure reliable operation over an extended temperature range. This includes, but is not limited to, Highly Accelerated Stress Test (HAST) or biased 85/85, temperature cycle, autoclave or unbiased HAST, electromigration, bond intermetallic life, and mold compound life. Such qualification testing should not be viewed as justifying use of this component beyond specified performance and environmental limits.

DGG OR DL PACKAGE
(TOP VIEW)

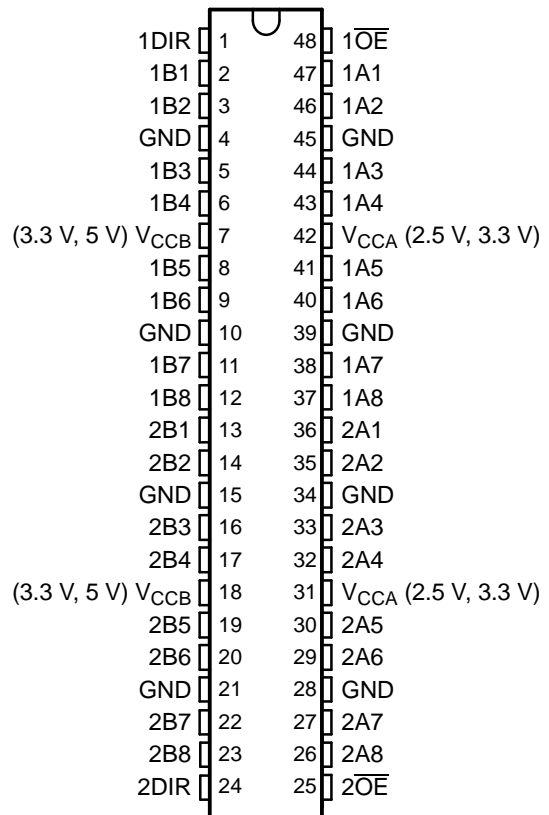

DESCRIPTION/ORDERING INFORMATION

This 16-bit (dual-octal) noninverting bus transceiver contains two separate supply rails. B port has V_{CCB} , which is set to operate at 3.3 V and 5 V. A port has V_{CCA} , which is set to operate at 2.5 V and 3.3 V. This allows for translation from a 2.5-V to a 3.3-V environment, and vice versa, or from a 3.3-V to a 5-V environment, and vice versa.

The SN74ALVC164245 is designed for asynchronous communication between data buses. The control circuitry (1DIR, 2DIR, 1OE, and 2OE) is powered by V_{CCA} .

To ensure the high-impedance state during power up or power down, the output-enable (\overline{OE}) input should be tied to V_{CC} through a pullup resistor; the minimum value of the resistor is determined by the current-sinking capability of the driver.

ORDERING INFORMATION

T_A	PACKAGE ⁽¹⁾		ORDERABLE PART NUMBER	TOP-SIDE MARKING
–40°C to 85°C	SSOP – DL	Reel of 1000	CALVC164245IDLREP	ALVC164245
	TSSOP – DGG	Reel of 2000	CALVC164245IDGGREP	ALVC164245
	VFBGA – GQL	Reel of 1000	CALVC164245IGQLREP	VC4245EP
	VFBGA – ZQL (Pb-free)		CALVC164245IZQLREP	
–55°C to 125°C	TSSOP – DGG	Reel of 2000	CALVC164245MDGGREP	C164245MEP

(1) Package drawings, standard packing quantities, thermal data, symbolization, and PCB design guidelines are available at www.ti.com/sc/package.



Please be aware that an important notice concerning availability, standard warranty, and use in critical applications of Texas Instruments semiconductor products and disclaimers thereto appears at the end of this data sheet.

Widebus is a trademark of Texas Instruments.

SN74ALVC164245-EP
16-BIT 2.5-V TO 3.3-V/3.3-V TO 5-V LEVEL-SHIFTING TRANSCEIVER
WITH 3-STATE OUTPUTS

SCAS774A–JUNE 2004–REVISED SEPTEMBER 2005

GQL OR ZQL PACKAGE
(TOP VIEW)

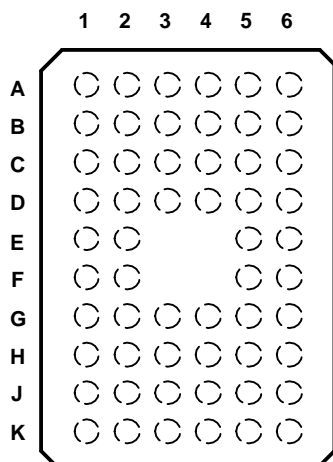

TERMINAL ASSIGNMENTS⁽¹⁾

	1	2	3	4	5	6
A	1DIR	NC	NC	NC	NC	1 \overline{OE}
B	1B2	1B1	GND	GND	1A1	1A2
C	1B4	1B3	V _{CCB}	V _{CCA}	1A3	1A4
D	1B6	1B5	GND	GND	1A5	1A6
E	1B8	1B7			1A7	1A8
F	2B1	2B2			2A2	2A1
G	2B3	2B4	GND	GND	2A4	2A3
H	2B5	2B6	V _{CCB}	V _{CCA}	2A6	2A5
J	2B7	2B8	GND	GND	2A8	2A7
K	2DIR	NC	NC	NC	NC	2 \overline{OE}

(1) NC – No internal connection

FUNCTION TABLE
(EACH 8-BIT SECTION)

INPUTS		OPERATION
\overline{OE}	DIR	
L	L	B data to A bus
L	H	A data to B bus
H	X	Isolation

LOGIC DIAGRAM (POSITIVE LOGIC)

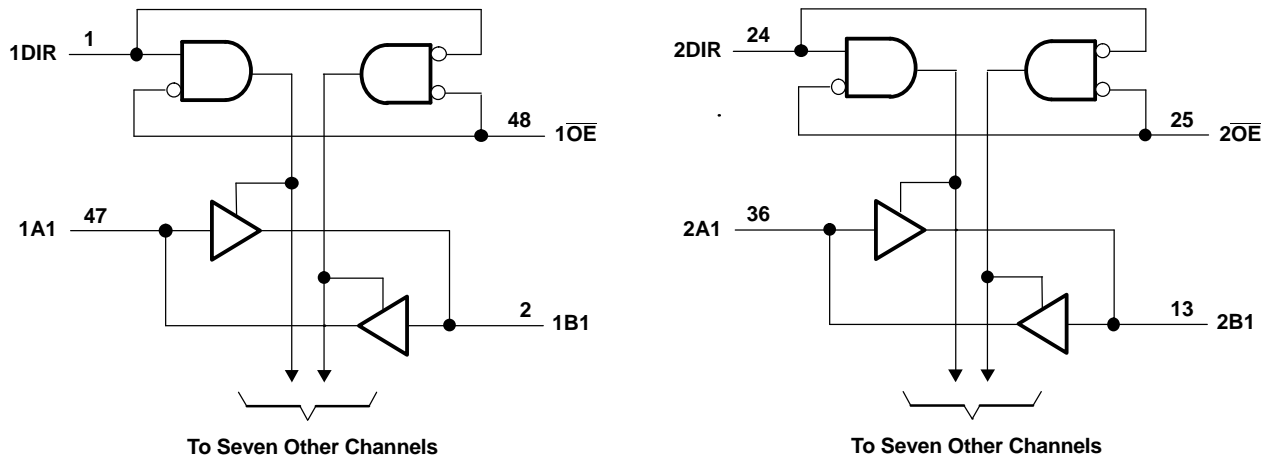

Pin numbers shown are for the DGG and DL packages.

Absolute Maximum Ratings⁽¹⁾

over operating free-air temperature range for V_{CCB} at 5 V and V_{CCA} at 3.3 V (unless otherwise noted)

			MIN	MAX	UNIT
V_{CCA}	Supply voltage range		-0.5	4.6	V
V_{CCB}			-0.5	6	
V_I	Input voltage range	Except I/O ports ⁽²⁾	-0.5	6	V
		I/O port A ⁽³⁾	-0.5	$V_{CCA} + 0.5$	
		I/O port B ⁽²⁾	-0.5	$V_{CCB} + 0.5$	
I_{IK}	Input clamp current	$V_I < 0$		-50	mA
I_{OK}	Output clamp current	$V_O < 0$		-50	mA
I_O	Continuous output current			±50	mA
	Continuous current through each V_{CC} or GND			±100	mA
θ_{JA}	Package thermal impedance ⁽⁴⁾	DGG package		70	°C/W
		DL package		63	
		GQL/ZQL package		42	
T_{stg}	Storage temperature range		-65	150	°C

- (1) Stresses beyond those listed under "absolute maximum ratings" may cause permanent damage to the device. These are stress ratings only, and functional operation of the device at these or any other conditions beyond those indicated under "recommended operating conditions" is not implied. Exposure to absolute-maximum-rated conditions for extended periods may affect device reliability.
- (2) This value is limited to 6 V maximum.
- (3) This value is limited to 4.6 V maximum.
- (4) The package thermal impedance is calculated in accordance with JESD 51-7.

SN74ALVC164245-EP
16-BIT 2.5-V TO 3.3-V/3.3-V TO 5-V LEVEL-SHIFTING TRANSCEIVER
WITH 3-STATE OUTPUTS

SCAS774A–JUNE 2004–REVISED SEPTEMBER 2005

Recommended Operating Conditions⁽¹⁾

for V_{CCB} at 3.3 V and 5 V

		MIN	MAX	UNIT	
V_{CCB}	Supply voltage	3	5.5	V	
V_{IH}	High-level input voltage	2		V	
V_{IL}	Low-level input voltage	$V_{CCB} = 3\text{ V to }3.6\text{ V}$	0.7	V	
		$V_{CCB} = 4.5\text{ V to }5.5\text{ V}$	0.8		
V_{IB}	Input voltage	0	V_{CCB}	V	
V_{OB}	Output voltage	0	V_{CCB}	V	
I_{OH}	High-level output current		–24	mA	
I_{OL}	Low-level output current		24	mA	
$\Delta t/\Delta v$	Input transition rise or fall rate		10	ns/V	
T_A	Operating free-air temperature	CALVC16245I	–40	85	°C
		CALVC16245M	–55	125	

(1) All unused inputs of the device must be held at V_{CC} or GND to ensure proper device operation. Refer to the TI application report, *Implications of Slow or Floating CMOS Inputs*, literature number SCBA004.

Recommended Operating Conditions⁽¹⁾

for V_{CCA} at 2.5 V and 3.3 V

		MIN	MAX	UNIT	
V_{CCA}	Supply voltage	2.3	3.6	V	
V_{IH}	High-level input voltage	$V_{CCA} = 2.3\text{ V to }2.7\text{ V}$	1.7	V	
		$V_{CCA} = 3\text{ V to }3.6\text{ V}$	2		
V_{IL}	Low-level input voltage	$V_{CCA} = 2.3\text{ V to }2.7\text{ V}$	0.7	V	
		$V_{CCA} = 3\text{ V to }3.6\text{ V}$	0.8		
V_{IA}	Input voltage	0	V_{CCA}	V	
V_{OA}	Output voltage	0	V_{CCA}	V	
I_{OH}	High-level output current	$V_{CCA} = 2.3\text{ V}$	–18	mA	
		$V_{CCA} = 3\text{ V}$	–24		
I_{OL}	Low-level output current	$V_{CCA} = 2.3\text{ V}$	18	mA	
		$V_{CCA} = 3\text{ V}$	24		
$\Delta t/\Delta v$	Input transition rise or fall rate		10	ns/V	
T_A	Operating free-air temperature	CALVC16245I	–40	85	°C
		CALVC16245M	–55	125	

(1) All unused inputs of the device must be held at V_{CC} or GND to ensure proper device operation. Refer to the TI application report, *Implications of Slow or Floating CMOS Inputs*, literature number SCBA004.

Electrical Characteristics

 over recommended operating free-air temperature range for $V_{CCA} = 2.7\text{ V to }3.6\text{ V}$ and $V_{CCB} = 4.5\text{ V to }5.5\text{ V}$
 (unless otherwise noted)

PARAMETER		TEST CONDITIONS	V_{CCA}	V_{CCB}	CALVC164245I			CALVC164245M			UNIT	
					MIN	TYP ⁽¹⁾	MAX	MIN	TYP ⁽¹⁾	MAX		
V_{OH}	B to A	$I_{OH} = -100\ \mu\text{A}$	2.7 V to 3.6 V		$V_{CC} - 0.2$			$V_{CC} - 0.2$			V	
		$I_{OH} = -12\ \text{mA}$	2.7 V		2.2			2.2				
		$I_{OH} = -24\ \text{mA}$	3 V		2.4			2.4				
	A to B	$I_{OL} = 100\ \mu\text{A}$		4.5 V		4.3			4.3			
		$I_{OL} = 100\ \mu\text{A}$		5.5 V		5.3			5.3			
		$I_{OL} = 24\ \text{mA}$		4.5 V		3.7			3.7			
				5.5 V		4.7			4.7			
V_{OL}	B to A	$I_{OL} = 100\ \mu\text{A}$	2.7 V to 3.6 V							0.2	0.2	
		$I_{OL} = 12\ \text{mA}$	2.7 V							0.4	0.4	
		$I_{OL} = 24\ \text{mA}$	3 V							0.55	0.55	
	A to B	$I_{OL} = 100\ \mu\text{A}$		4.5 V to 5.5 V						0.2	0.2	
		$I_{OL} = 24\ \text{mA}$		4.5 V to 5.5 V						0.55	0.55	
I_I	Control inputs	$V_I = V_{CCA}/V_{CCB}$ or GND	3.6 V	5.5 V						± 5	μA	
$I_{OZ}^{(2)}$	A or B port	$V_O = V_{CCA}/V_{CCB}$ or GND	3.6 V	5.5 V						± 10	μA	
I_{CC}		$V_I = V_{CCA}/V_{CCB}$ or GND, $I_O = 0$	5.5 V	5.5 V						40	μA	
$\Delta I_{CC}^{(3)}$		One input at $V_{CCA}/V_{CCB} - 0.6\text{ V}$, Other inputs at V_{CCA}/V_{CCB} or GND	3 V to 3.6 V	4.5 V to 5.5 V						750	μA	
C_i	Control inputs	$V_I = V_{CCA}/V_{CCB}$ or GND	3.3 V	5 V						6.5	pF	
C_{io}	A or B port	$V_O = V_{CCA}/V_{CCB}$ or GND	3.3 V	3.3 V						8.5	pF	

 (1) All typical values are at $V_{CCA} = 3.3\text{ V}$ and $V_{CCB} = 5\text{ V}$, $T_A = 25^\circ\text{C}$.

 (2) For I/O ports, the parameter I_{OZ} includes the input leakage current.

 (3) This is the increase in supply current for each input that is at one of the specified TTL voltage levels, rather than at 0 or the associated V_{CC} .

SN74ALVC164245-EP
16-BIT 2.5-V TO 3.3-V/3.3-V TO 5-V LEVEL-SHIFTING TRANSCEIVER
WITH 3-STATE OUTPUTS

SCAS774A–JUNE 2004–REVISED SEPTEMBER 2005

Electrical Characteristics

over recommended operating free-air temperature range for $V_{CCA} = 2.3\text{ V to }2.7\text{ V}$ and $V_{CCB} = 3\text{ V to }3.6\text{ V}$
(unless otherwise noted)

PARAMETER		TEST CONDITIONS	V_{CCA}	V_{CCB}	CALVC164245I		CALVC164245M		UNIT
					MIN	MAX	MIN	MAX	
V_{OH}	B to A	$I_{OH} = -100\ \mu\text{A}$	2.3 V to 2.7 V	3 V to 3.6 V	$V_{CCA} - 0.2$		$V_{CCA} - 0.2$		V
		$I_{OH} = -8\ \text{mA}$	2.3 V	3 V to 3.6 V	1.7		1.7		
		$I_{OH} = -12\ \text{mA}$	2.7 V	3 V to 3.6 V	1.8		1.8		
	A to B	$I_{OL} = 100\ \mu\text{A}$	2.3 V to 2.7 V	3 V to 3.6 V	$V_{CCB} - 0.2$		$V_{CCB} - 0.2$		
		$I_{OL} = 18\ \text{mA}$	2.3 V to 2.7 V	3 V	2.2		2.2		
V_{OL}	B to A	$I_{OL} = 100\ \mu\text{A}$	2.3 V to 2.7 V	3 V to 3.6 V			0.2	0.2	V
		$I_{OL} = 12\ \text{mA}$	2.3 V	3 V to 3.6 V			0.6	0.6	
	A to B	$I_{OL} = 100\ \mu\text{A}$	2.3 V to 2.7 V	3 V to 3.6 V			0.2	0.2	
		$I_{OL} = 18\ \text{mA}$	2.3 V	3 V			0.55	0.55	
I_i	Control inputs	$V_i = V_{CCA}/V_{CCB}$ or GND	2.3 V to 2.7 V	3 V to 3.6 V			± 5	± 5	μA
$I_{OZ}^{(1)}$	A or B port	$V_O = V_{CCA}/V_{CCB}$ or GND	2.3 V to 2.7 V	3 V to 3.6 V			± 10	± 10	μA
I_{CC}		$V_i = V_{CCA}/V_{CCB}$ or GND, $I_O = 0$	2.3 V to 2.7 V	3 V to 3.6 V			20	40	μA
$\Delta I_{CC}^{(2)}$		One input at $V_{CCA}/V_{CCB} - 0.6\text{ V}$, Other inputs at V_{CCA}/V_{CCB} or GND	2.3 V to 2.7 V	3 V to 3.6 V			750	750	μA

(1) For I/O ports, the parameter I_{OZ} includes the input leakage current.

(2) This is the increase in supply current for each input that is at one of the specified TTL voltage levels, rather than at 0 or the associated V_{CC} .

Switching Characteristics

over recommended operating free-air temperature range (unless otherwise noted) (see [Figure 1](#) through [Figure 4](#))

PARAMETER	FROM (INPUT)	TO (OUTPUT)	CALVC16245I						UNIT
			$V_{CCB} = 3.3\text{ V} \pm 0.3\text{ V}$		$V_{CCB} = 5\text{ V} \pm 0.5\text{ V}$				
			$V_{CCA} = 2.5\text{ V} \pm 0.2\text{ V}$		$V_{CCA} = 2.7\text{ V}$		$V_{CCA} = 3.3\text{ V} \pm 0.3\text{ V}$		
			MIN	MAX	MIN	MAX	MIN	MAX	
t_{pd}	A	B	7.6		5.9		1	5.8	ns
	B	A	7.6		6.7		1.2	5.8	
t_{en}	\overline{OE}	B	11.5		9.3		1	8.9	ns
t_{dis}	\overline{OE}	B	10.5		9.2		2.1	9.5	ns
t_{en}	\overline{OE}	A	12.3		10.2		2	9.1	ns
t_{dis}	\overline{OE}	A	9.3		9		2.9	8.6	ns

Switching Characteristics

over recommended operating free-air temperature range (unless otherwise noted) (see [Figure 1](#) through [Figure 4](#))

PARAMETER	FROM (INPUT)	TO (OUTPUT)	CALVC16245M						UNIT
			$V_{CCB} = 3.3\text{ V} \pm 0.3\text{ V}$		$V_{CCB} = 5\text{ V} \pm 0.5\text{ V}$				
			$V_{CCA} = 2.5\text{ V} \pm 0.2\text{ V}$		$V_{CCA} = 2.7\text{ V}$		$V_{CCA} = 3.3\text{ V} \pm 0.3\text{ V}$		
			MIN	MAX	MIN	MAX	MIN	MAX	
t_{pd}	A	B	8.6		6.9		1	6.8	ns
	B	A	8.6		7.7		1.2	6.8	
t_{en}	\overline{OE}	B	12.5		10.3		1	9.9	ns
t_{dis}	\overline{OE}	B	11.5		10.2		2.1	10.5	ns
t_{en}	\overline{OE}	A	14.5		11.2		2	10.1	ns
t_{dis}	\overline{OE}	A	11.3		11		2.9	10.6	ns

Operating Characteristics

$T_A = 25^\circ\text{C}$

PARAMETER		TEST CONDITIONS	$V_{CCB} = 3.3\text{ V}$	$V_{CCB} = 5\text{ V}$	UNIT
			$V_{CCA} = 2.5\text{ V}$	$V_{CCA} = 3.3\text{ V}$	
			TYP	TYP	
C_{pd} Power dissipation capacitance	Outputs enabled (B)	$C_L = 50\text{ pF}, f = 10\text{ MHz}$	55	56	pF
	Outputs disabled (B)		27	6	
	Outputs enabled (A)	$C_L = 50\text{ pF}, f = 10\text{ MHz}$	118	56	
	Outputs disabled (A)		58	6	

Power-Up Considerations⁽¹⁾

TI level-translation devices offer an opportunity for successful mixed-voltage signal design. A proper power-up sequence always should be followed to avoid excessive supply current, bus contention, oscillations, or other anomalies caused by improperly biased device pins. To guard against such power-up problems, take these precautions:

1. Connect ground before any supply voltage is applied.
 2. Power up the control side of the device (V_{CCA} for all four of these devices).
 3. Tie \overline{OE} to V_{CCA} with a pullup resistor so that it ramps with V_{CCA} .
 4. Depending on the direction of the data path, DIR can be high or low. If DIR high is needed (A data to B bus), ramp it with V_{CCA} . Otherwise, keep DIR low.
- (1) Refer to the TI application report, *Texas Instruments Voltage-Level-Translation Devices*, literature number SCEA021.

PARAMETER MEASUREMENT INFORMATION

$V_{CCA} = 2.5\text{ V} \pm 0.2\text{ V}$ to $V_{CCB} = 3.3\text{ V} \pm 0.3\text{ V}$

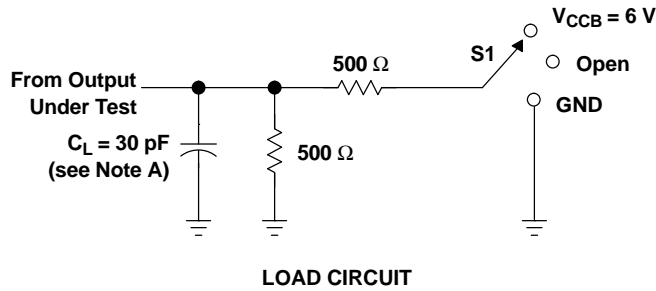

TEST	S1
t_{pd}	Open
t_{PLZ}/t_{PZL}	$V_{CCB} = 6\text{ V}$
t_{PHZ}/t_{PZH}	GND

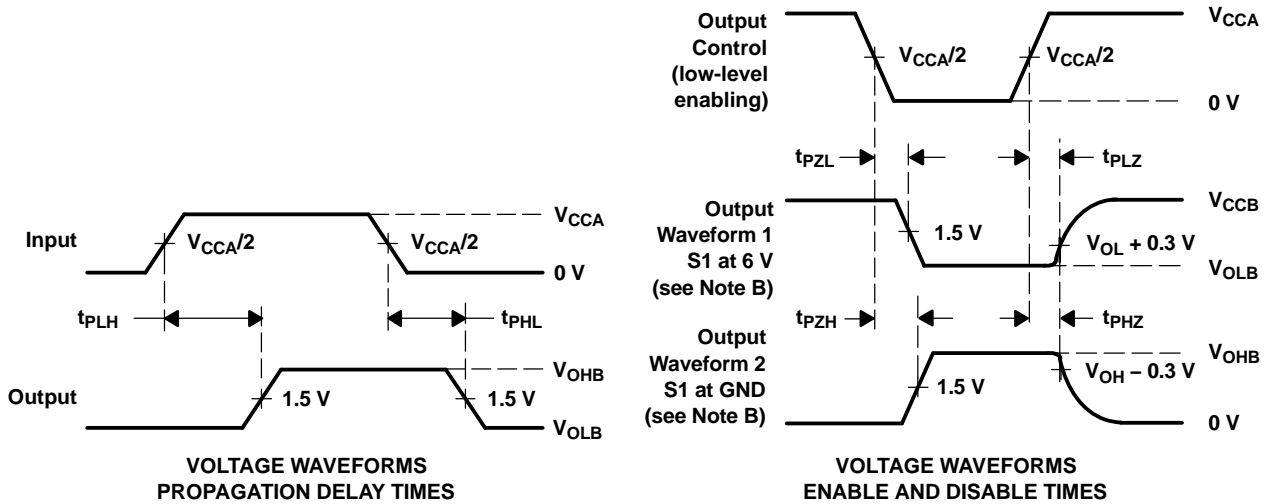

- NOTES: A. C_L includes probe and jig capacitance.
 B. Waveform 1 is for an output with internal conditions such that the output is low, except when disabled by the output control. Waveform 2 is for an output with internal conditions such that the output is high, except when disabled by the output control.
 C. All input pulses are supplied by generators having the following characteristics: $PRR \leq 10\text{ MHz}$, $Z_O = 50\ \Omega$, $t_r \leq 2\text{ ns}$, $t_f \leq 2\text{ ns}$.
 D. The outputs are measured one at a time, with one transition per measurement.
 E. t_{PLZ} and t_{PHZ} are the same as t_{dis} .
 F. t_{PZL} and t_{PZH} are the same as t_{en} .
 G. t_{PLH} and t_{PHL} are the same as t_{pd} .

Figure 1. Load Circuit and Voltage Waveforms

SN74ALVC164245-EP
16-BIT 2.5-V TO 3.3-V/3.3-V TO 5-V LEVEL-SHIFTING TRANSCEIVER
WITH 3-STATE OUTPUTS

SCAS774A–JUNE 2004–REVISED SEPTEMBER 2005

PARAMETER MEASUREMENT INFORMATION

$V_{CCB} = 3.3\text{ V} \pm 0.3\text{ V}$ to $V_{CCA} = 2.5\text{ V} \pm 0.2\text{ V}$

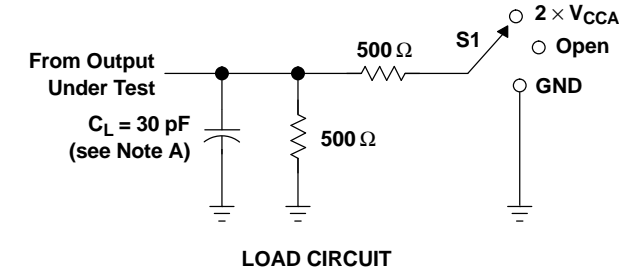

TEST	S1
t_{pd}	Open
t_{PLZ}/t_{PZL}	$2 \times V_{CCA}$
t_{PHZ}/t_{PZH}	GND

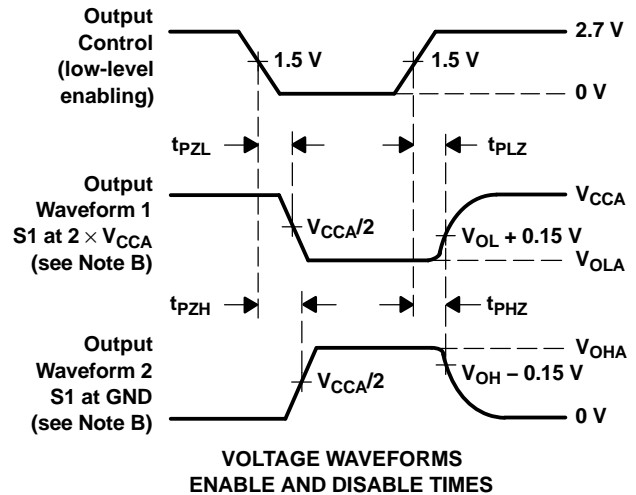
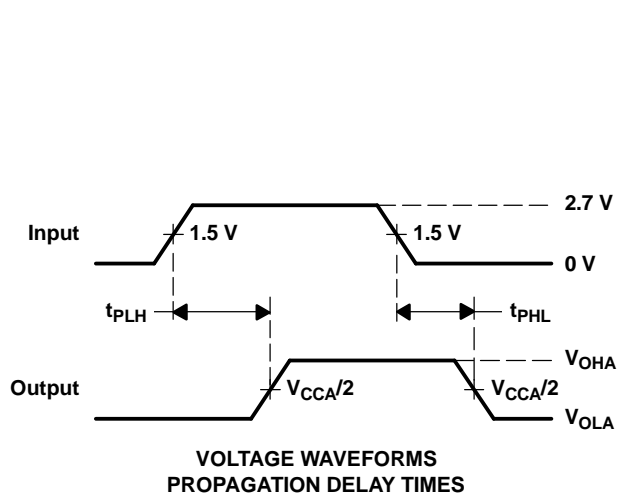

- NOTES:
- A. C_L includes probe and jig capacitance.
 - B. Waveform 1 is for an output with internal conditions such that the output is low, except when disabled by the output control. Waveform 2 is for an output with internal conditions such that the output is high, except when disabled by the output control.
 - C. All input pulses are supplied by generators having the following characteristics: $PRR \leq 10\text{ MHz}$, $Z_O = 50\ \Omega$, $t_r \leq 2\text{ ns}$, $t_f \leq 2\text{ ns}$.
 - D. The outputs are measured one at a time, with one transition per measurement.
 - E. t_{PLZ} and t_{PHZ} are the same as t_{dis} .
 - F. t_{PZL} and t_{PZH} are the same as t_{en} .
 - G. t_{PLH} and t_{PHL} are the same as t_{pd} .

Figure 2. Load Circuit and Voltage Waveforms

PARAMETER MEASUREMENT INFORMATION

$V_{CCA} = 3.3\text{ V} \pm 0.3\text{ V}$ to $V_{CCB} = 5\text{ V} \pm 0.5\text{ V}$

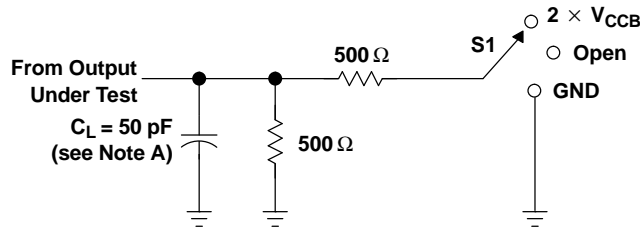

LOAD CIRCUIT

TEST	S1
t_{pd}	Open
t_{PLZ}/t_{PZL}	$2 \times V_{CCB}$
t_{PHZ}/t_{PZH}	GND

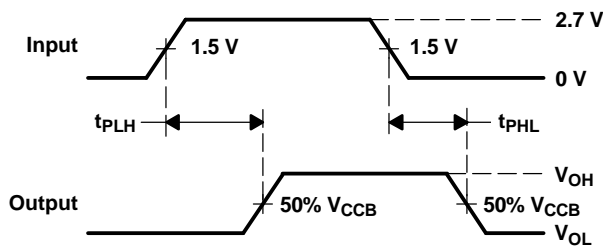

VOLTAGE WAVEFORMS
PROPAGATION DELAY TIMES

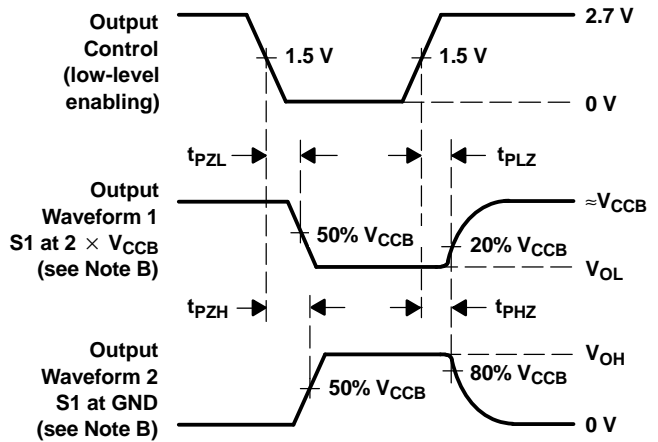

VOLTAGE WAVEFORMS
ENABLE AND DISABLE TIMES

- NOTES:
- A. C_L includes probe and jig capacitance.
 - B. Waveform 1 is for an output with internal conditions such that the output is low, except when disabled by the output control. Waveform 2 is for an output with internal conditions such that the output is high, except when disabled by the output control.
 - C. All input pulses are supplied by generators having the following characteristics: $PRR \leq 10\text{ MHz}$, $Z_O = 50\ \Omega$, $t_r \leq 2.5\text{ ns}$, $t_f \leq 2.5\text{ ns}$.
 - D. The outputs are measured one at a time, with one transition per measurement.
 - E. t_{PLZ} and t_{PHZ} are the same as t_{dis} .
 - F. t_{PZL} and t_{PZH} are the same as t_{en} .
 - G. t_{PLH} and t_{PHL} are the same as t_{pd} .

Figure 3. Load Circuit and Voltage Waveforms

PARAMETER MEASUREMENT INFORMATION
 $V_{CCB} = 5\text{ V} \pm 0.5\text{ V}$ to $V_{CCA} = 2.7\text{ V}$ and $3.3\text{ V} \pm 0.3\text{ V}$

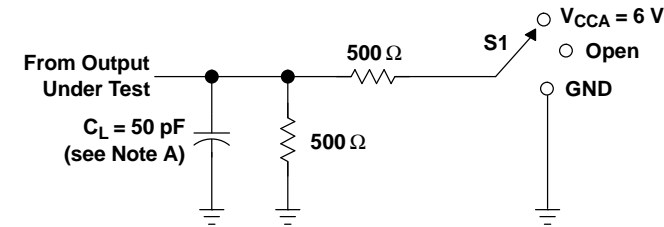

LOAD CIRCUIT

TEST	S1
t_{pd}	Open
t_{PLZ}/t_{PZL}	$V_{CCA} = 6\text{ V}$
t_{PHZ}/t_{PZH}	GND

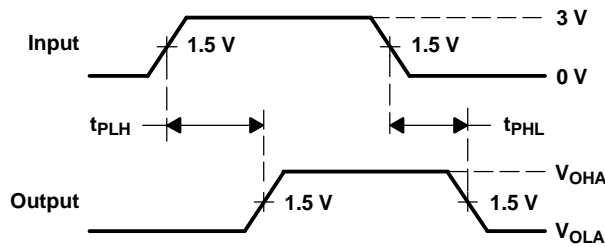

VOLTAGE WAVEFORMS
 PROPAGATION DELAY TIMES

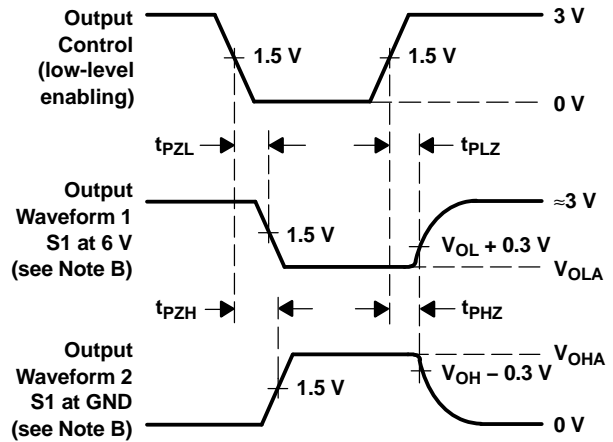

VOLTAGE WAVEFORMS
 ENABLE AND DISABLE TIMES

- NOTES:
- A. C_L includes probe and jig capacitance.
 - B. Waveform 1 is for an output with internal conditions such that the output is low, except when disabled by the output control. Waveform 2 is for an output with internal conditions such that the output is high, except when disabled by the output control.
 - C. All input pulses are supplied by generators having the following characteristics: $PRR \leq 10\text{ MHz}$, $Z_O = 50\ \Omega$, $t_r \leq 2.5\text{ ns}$, $t_f \leq 2.5\text{ ns}$.
 - D. The outputs are measured one at a time, with one transition per measurement.
 - E. t_{PLZ} and t_{PHZ} are the same as t_{dis} .
 - F. t_{PZL} and t_{PZH} are the same as t_{en} .
 - G. t_{PLH} and t_{PHL} are the same as t_{pd} .

Figure 4. Load Circuit and Voltage Waveforms

74ALVC164245MDGG*EP
Estimated Device Life at Elevated Temperatures Electromigration
and Wirebond Voiding Fail Modes

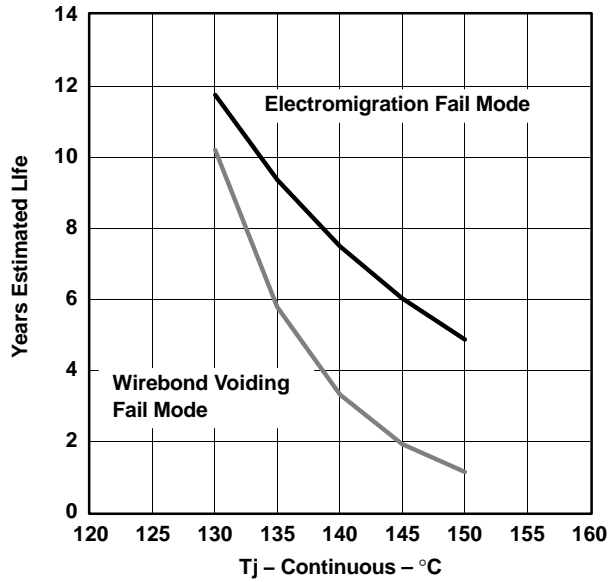

- A. Silicon operating life design goal is 10 years at 105°C junction temperature.

PACKAGING INFORMATION

Orderable Device	Status (1)	Package Type	Package Drawing	Pins	Package Qty	Eco Plan (2)	Lead finish/ Ball material (6)	MSL Peak Temp (3)	Op Temp (°C)	Device Marking (4/5)	Samples
CALVC164245IDGGREP	ACTIVE	TSSOP	DGG	48	2000	RoHS & Green	NIPDAU	Level-1-260C-UNLIM	-40 to 85	ALVC164245	Samples
CALVC164245IDLREP	ACTIVE	SSOP	DL	48	1000	RoHS & Green	NIPDAU	Level-1-260C-UNLIM	-40 to 85	ALVC164245	Samples
CALVC164245MDGGREP	ACTIVE	TSSOP	DGG	48	2000	RoHS & Green	NIPDAU	Level-1-260C-UNLIM	-55 to 125	C164245MEP	Samples
V62/05612-01XE	ACTIVE	SSOP	DL	48	1000	RoHS & Green	NIPDAU	Level-1-260C-UNLIM	-40 to 85	ALVC164245	Samples
V62/05612-01YE	ACTIVE	TSSOP	DGG	48	2000	RoHS & Green	NIPDAU	Level-1-260C-UNLIM	-40 to 85	ALVC164245	Samples
V62/05612-02YE	ACTIVE	TSSOP	DGG	48	2000	RoHS & Green	NIPDAU	Level-1-260C-UNLIM	-55 to 125	C164245MEP	Samples

(1) The marketing status values are defined as follows:

ACTIVE: Product device recommended for new designs.

LIFEBUY: TI has announced that the device will be discontinued, and a lifetime-buy period is in effect.

NRND: Not recommended for new designs. Device is in production to support existing customers, but TI does not recommend using this part in a new design.

PREVIEW: Device has been announced but is not in production. Samples may or may not be available.

OBSOLETE: TI has discontinued the production of the device.

(2) **RoHS:** TI defines "RoHS" to mean semiconductor products that are compliant with the current EU RoHS requirements for all 10 RoHS substances, including the requirement that RoHS substance do not exceed 0.1% by weight in homogeneous materials. Where designed to be soldered at high temperatures, "RoHS" products are suitable for use in specified lead-free processes. TI may reference these types of products as "Pb-Free".

RoHS Exempt: TI defines "RoHS Exempt" to mean products that contain lead but are compliant with EU RoHS pursuant to a specific EU RoHS exemption.

Green: TI defines "Green" to mean the content of Chlorine (Cl) and Bromine (Br) based flame retardants meet JS709B low halogen requirements of <=1000ppm threshold. Antimony trioxide based flame retardants must also meet the <=1000ppm threshold requirement.

(3) MSL, Peak Temp. - The Moisture Sensitivity Level rating according to the JEDEC industry standard classifications, and peak solder temperature.

(4) There may be additional marking, which relates to the logo, the lot trace code information, or the environmental category on the device.

(5) Multiple Device Markings will be inside parentheses. Only one Device Marking contained in parentheses and separated by a "~" will appear on a device. If a line is indented then it is a continuation of the previous line and the two combined represent the entire Device Marking for that device.

(6) Lead finish/Ball material - Orderable Devices may have multiple material finish options. Finish options are separated by a vertical ruled line. Lead finish/Ball material values may wrap to two lines if the finish value exceeds the maximum column width.

Important Information and Disclaimer: The information provided on this page represents TI's knowledge and belief as of the date that it is provided. TI bases its knowledge and belief on information provided by third parties, and makes no representation or warranty as to the accuracy of such information. Efforts are underway to better integrate information from third parties. TI has taken and continues to take reasonable steps to provide representative and accurate information but may not have conducted destructive testing or chemical analysis on incoming materials and chemicals. TI and TI suppliers consider certain information to be proprietary, and thus CAS numbers and other limited information may not be available for release.

In no event shall TI's liability arising out of such information exceed the total purchase price of the TI part(s) at issue in this document sold by TI to Customer on an annual basis.

OTHER QUALIFIED VERSIONS OF SN74ALVC164245-EP :

- Catalog: [SN74ALVC164245](#)

NOTE: Qualified Version Definitions:

- Catalog - TI's standard catalog product

TAPE AND REEL INFORMATION

QUADRANT ASSIGNMENTS FOR PIN 1 ORIENTATION IN TAPE

*All dimensions are nominal

Device	Package Type	Package Drawing	Pins	SPQ	Reel Diameter (mm)	Reel Width W1 (mm)	A0 (mm)	B0 (mm)	K0 (mm)	P1 (mm)	W (mm)	Pin1 Quadrant
CALVC164245IDGGREP	TSSOP	DGG	48	2000	330.0	24.4	8.6	13.0	1.8	12.0	24.0	Q1
CALVC164245IDLREP	SSOP	DL	48	1000	330.0	32.4	11.35	16.2	3.1	16.0	32.0	Q1
CALVC164245MDGGREP	TSSOP	DGG	48	2000	330.0	24.4	8.6	13.0	1.8	12.0	24.0	Q1

TAPE AND REEL BOX DIMENSIONS



*All dimensions are nominal

Device	Package Type	Package Drawing	Pins	SPQ	Length (mm)	Width (mm)	Height (mm)
CALVC164245IDGGREP	TSSOP	DGG	48	2000	367.0	367.0	45.0
CALVC164245IDLREP	SSOP	DL	48	1000	367.0	367.0	55.0
CALVC164245MDGGREP	TSSOP	DGG	48	2000	356.0	356.0	41.0

MECHANICAL DATA

DL (R-PDSO-G48)

PLASTIC SMALL-OUTLINE PACKAGE

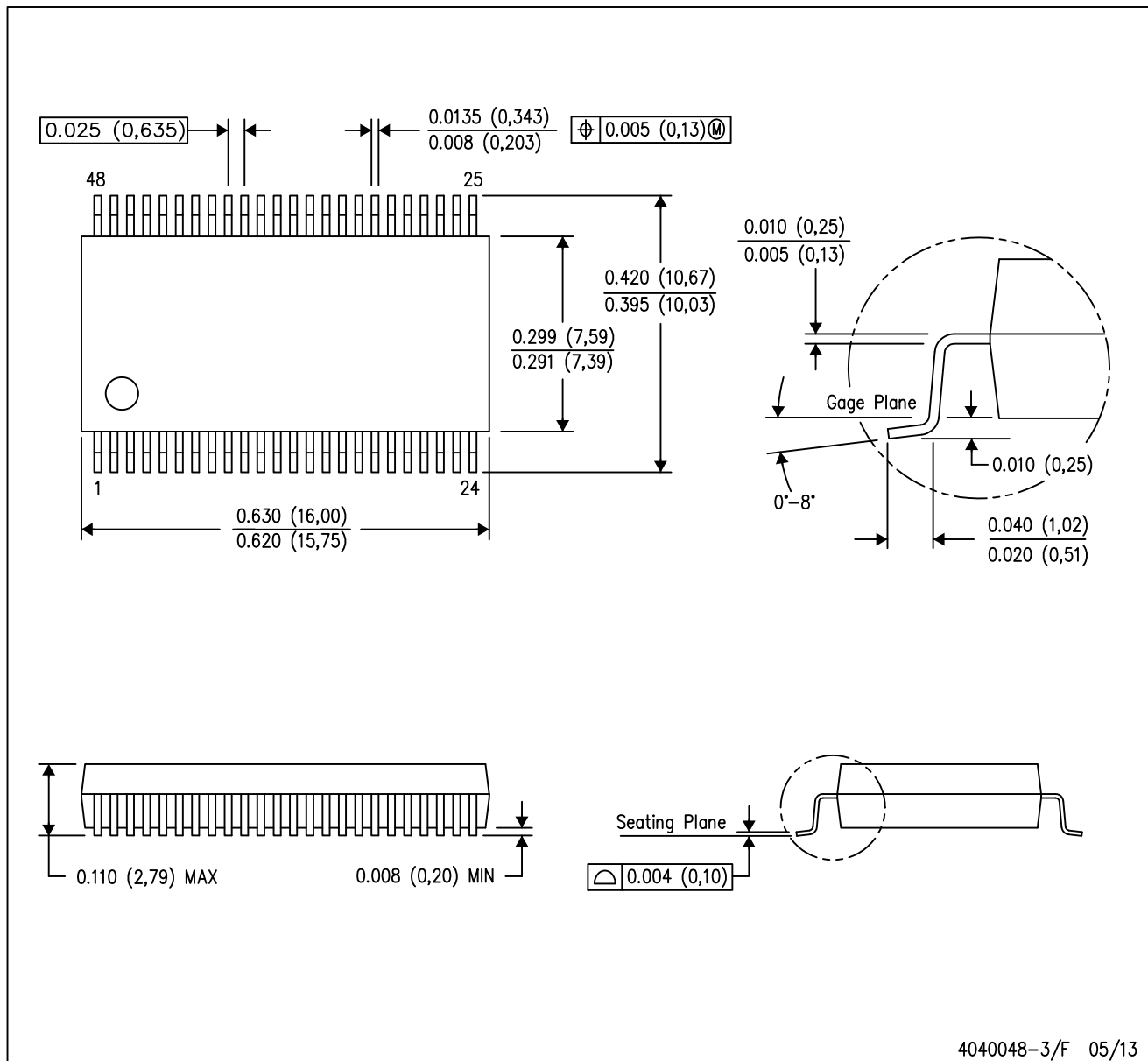

- NOTES:
- All linear dimensions are in inches (millimeters).
 - This drawing is subject to change without notice.
 - Body dimensions do not include mold flash or protrusion not to exceed 0.006 (0,15).
 - Falls within JEDEC MO-118

PowerPAD is a trademark of Texas Instruments.

EXAMPLE BOARD LAYOUT

DGG0048A

TSSOP - 1.2 mm max height

SMALL OUTLINE PACKAGE

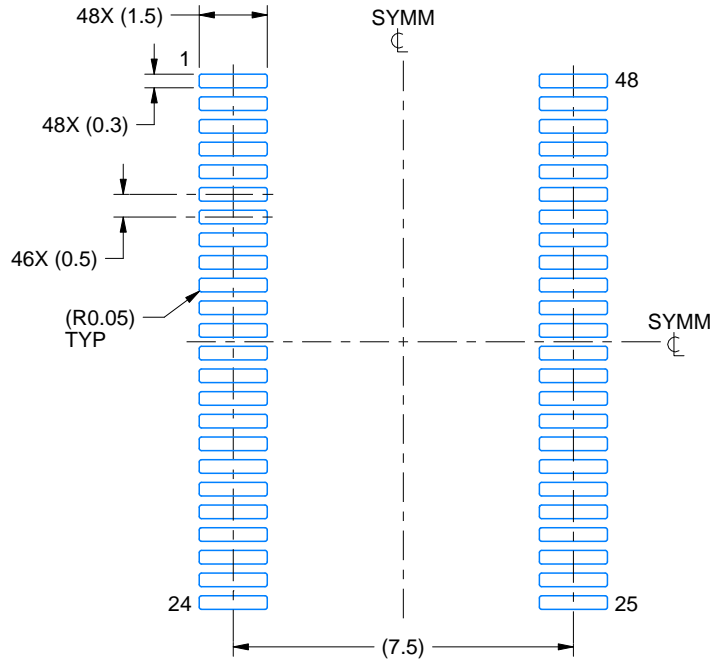

LAND PATTERN EXAMPLE
SCALE:6X

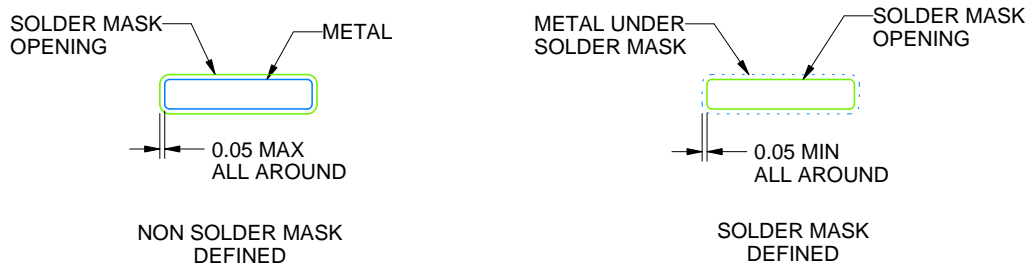

SOLDER MASK DETAILS

4214859/B 11/2020

NOTES: (continued)

5. Publication IPC-7351 may have alternate designs.
6. Solder mask tolerances between and around signal pads can vary based on board fabrication site.

EXAMPLE STENCIL DESIGN

DGG0048A

TSSOP - 1.2 mm max height

SMALL OUTLINE PACKAGE

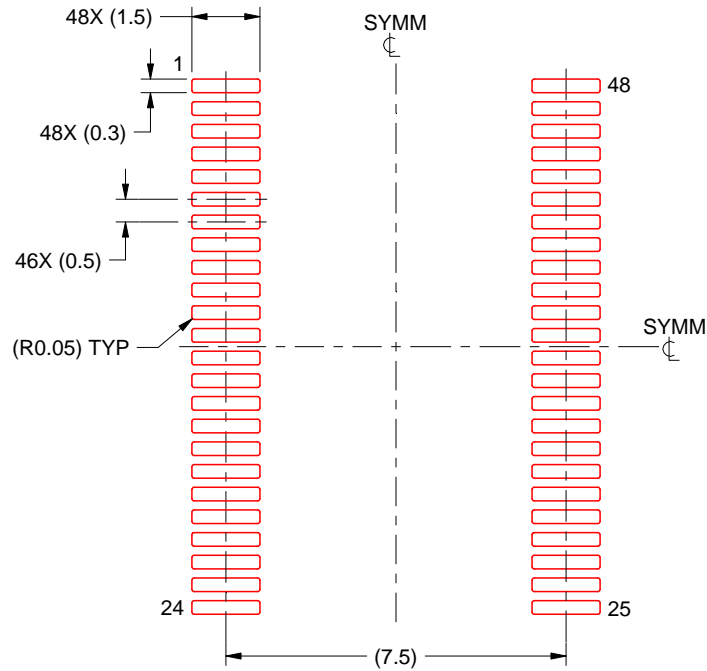

SOLDER PASTE EXAMPLE
BASED ON 0.125 mm THICK STENCIL
SCALE:6X

4214859/B 11/2020

NOTES: (continued)

7. Laser cutting apertures with trapezoidal walls and rounded corners may offer better paste release. IPC-7525 may have alternate design recommendations.
8. Board assembly site may have different recommendations for stencil design.

DGG (R-PDSO-G**)

PLASTIC SMALL-OUTLINE PACKAGE

48 PINS SHOWN

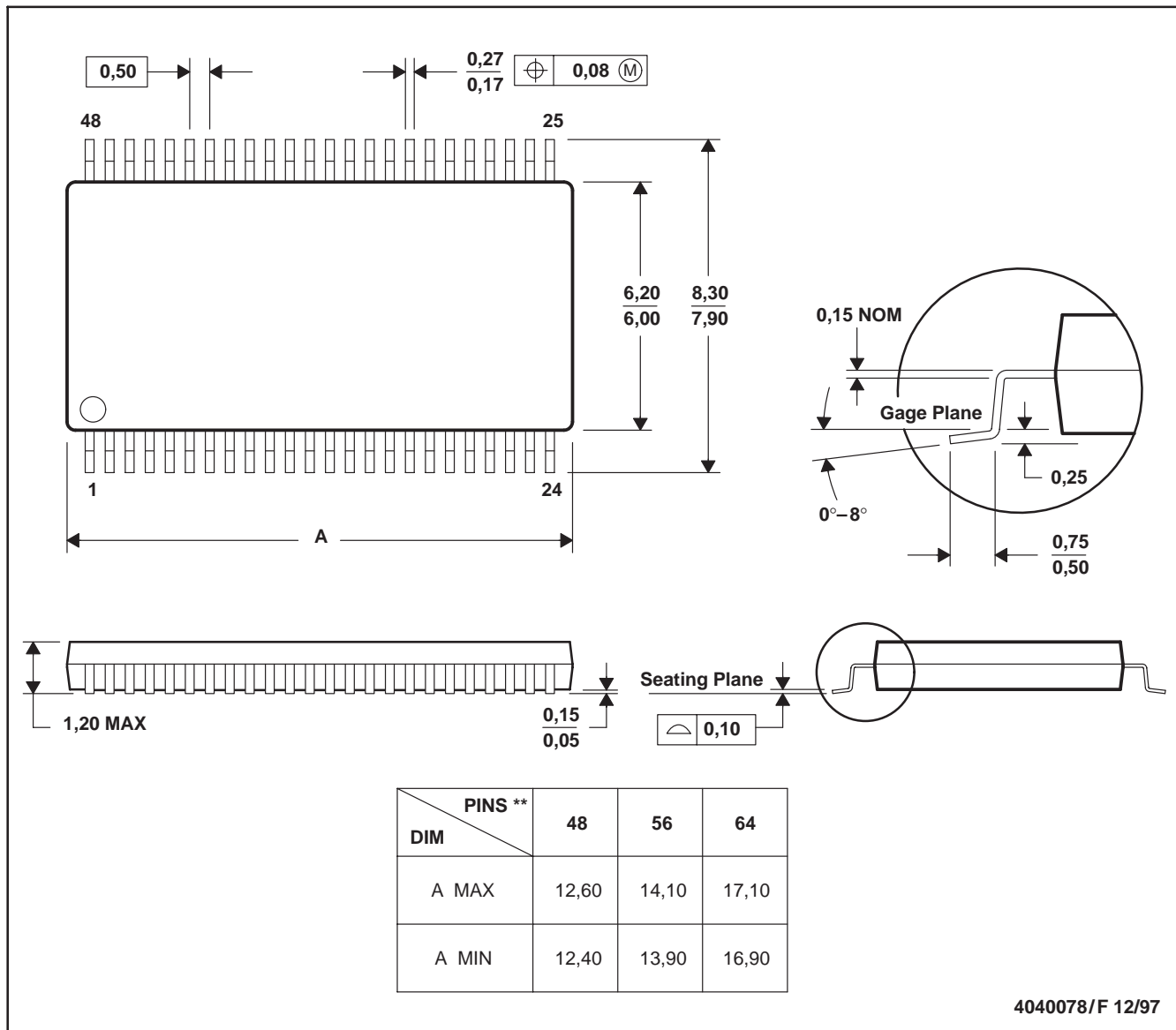

- NOTES: A. All linear dimensions are in millimeters.
 B. This drawing is subject to change without notice.
 C. Body dimensions do not include mold protrusion not to exceed 0,15.
 D. Falls within JEDEC MO-153

IMPORTANT NOTICE AND DISCLAIMER

TI PROVIDES TECHNICAL AND RELIABILITY DATA (INCLUDING DATA SHEETS), DESIGN RESOURCES (INCLUDING REFERENCE DESIGNS), APPLICATION OR OTHER DESIGN ADVICE, WEB TOOLS, SAFETY INFORMATION, AND OTHER RESOURCES "AS IS" AND WITH ALL FAULTS, AND DISCLAIMS ALL WARRANTIES, EXPRESS AND IMPLIED, INCLUDING WITHOUT LIMITATION ANY IMPLIED WARRANTIES OF MERCHANTABILITY, FITNESS FOR A PARTICULAR PURPOSE OR NON-INFRINGEMENT OF THIRD PARTY INTELLECTUAL PROPERTY RIGHTS.

These resources are intended for skilled developers designing with TI products. You are solely responsible for (1) selecting the appropriate TI products for your application, (2) designing, validating and testing your application, and (3) ensuring your application meets applicable standards, and any other safety, security, regulatory or other requirements.

These resources are subject to change without notice. TI grants you permission to use these resources only for development of an application that uses the TI products described in the resource. Other reproduction and display of these resources is prohibited. No license is granted to any other TI intellectual property right or to any third party intellectual property right. TI disclaims responsibility for, and you will fully indemnify TI and its representatives against, any claims, damages, costs, losses, and liabilities arising out of your use of these resources.

TI's products are provided subject to [TI's Terms of Sale](#) or other applicable terms available either on ti.com or provided in conjunction with such TI products. TI's provision of these resources does not expand or otherwise alter TI's applicable warranties or warranty disclaimers for TI products.

TI objects to and rejects any additional or different terms you may have proposed.

Mailing Address: Texas Instruments, Post Office Box 655303, Dallas, Texas 75265
Copyright © 2022, Texas Instruments Incorporated

Looking for pricing, stock, or lifecycle information?

Click below to explore more details on WIN SOURCE:

 [View CALVC164245IDGGREP](#) on WIN SOURCE

 [Texas Instruments](#) Information

Optimize Your Supply Chain with WIN SOURCE Solutions

-  Global Sourcing Solution
-  Obsolete Management
-  Cost Control Management
-  Shortage Management
-  Alternative Solution
-  Excess Inventory Management