



**THE DATASHEET OF  
APT30DQ120KG**



# APT30DQ120KG Ultrafast Soft Recovery Rectifier Diode

## Product Overview

The APT30DQ120KG is a 1200 V, 30 A Ultrafast Soft Recovery Rectifier diode in a TO-220 package.

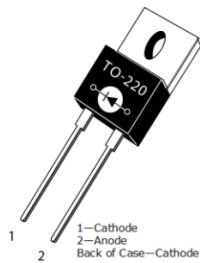

### Features

The following are key features of the APT30DQ120KG device:

- Ultrafast recovery times
- Soft recovery characteristics
- Low forward voltage
- Low leakage current
- Avalanche-energy rated
- RoHS compliant
- AEC-Q101 qualified

### Benefits

The following are benefits of the APT30DQ120KG device:

- Low switching losses
- Low noise (EMI) switching
- High switching frequency
- Higher reliability systems
- Increased system power density

### Applications

The APT30DQ120KG device is designed for the following applications:

- Power factor correction (PFC)
- Anti-parallel diode
  - Switch-mode power supply
  - Inverters/converters
  - Motor controllers
- Freewheeling diode
  - Switch-mode power supply
  - Inverters/converters
- Snubber/clamp diode

## Device Specifications

This section shows the specifications of the APT30DQ120KG device.

### Absolute Maximum Ratings

The following table shows the absolute maximum ratings of the APT30DQ120KG device.  $T_C = 25\text{ }^\circ\text{C}$  unless otherwise specified.

**Table 1 • Absolute Maximum Ratings**

Symbol	Parameter	Ratings	Unit
$V_R$	Maximum DC reverse voltage	1200	V
$V_{RRM}$	Maximum peak repetitive reverse voltage		
$V_{RWM}$	Maximum working peak reverse voltage		
$I_{F(AV)}$	Maximum average forward current ( $T_C = 103\text{ }^\circ\text{C}$ , duty cycle = 0.5)	30	A
$I_{FSM}$	Non-repetitive forward surge current ( $T_J = 45\text{ }^\circ\text{C}$ , 8.3 ms)	210	
$E_{AVL}$	Avalanche energy (1 A, 40 mH)	20	mJ

The following table shows the thermal and mechanical characteristics of the APT30DQ120KG device.

**Table 2 • Thermal and Mechanical Characteristics**

Symbol	Characteristic/Test Conditions	Min	Typ	Max	Unit
$R_{\theta JC}$	Junction-to-case thermal resistance			0.80	$^\circ\text{C}/\text{W}$
$T_J, T_{STG}$	Operating and storage temperature range	-55		175	$^\circ\text{C}$
$T_L$	Lead temperature for 10 seconds			300	
$Wt$	Package weight		0.07		oz
			1.9		g
	Mounting torque, 6-32 or M3 screw			10	lbf•in
				1.1	N•m

## Electrical Performance

The following table shows the static characteristics of the APT30DQ120KG device.  $T_J = 25\text{ }^\circ\text{C}$  unless otherwise specified.

**Table 3 • Static Characteristics**

Symbol	Characteristic	Test Conditions	Min	Typ	Max	Unit
$V_F$	Forward voltage	$I_F = 30\text{ A}$		2.8	3.3	V
		$I_F = 60\text{ A}$		3.4		
		$I_F = 30\text{ A}, T_J = 125\text{ }^\circ\text{C}$		2.1		
$I_{RM}$	Maximum reverse leakage current	$V_R = 1200\text{ V}$			100	$\mu\text{A}$
		$V_R = 1200\text{ V}, T_J = 125\text{ }^\circ\text{C}$			500	
$C_J$	Junction capacitance	$V_R = 200\text{ V}$		36		pF

The following table shows the dynamic characteristics of the APT30DQ120KG device.

**Table 4 • Dynamic Characteristics**

Symbol	Characteristic	Test Conditions	Min	Typ	Max	Unit
$t_{rr}$	Reverse recovery time	$I_F = 1\text{ A}, di_F/dt = -100\text{ A}/\mu\text{s}$ $V_R = 30\text{ V}$		26		ns
$t_{rr}$	Reverse recovery time	$I_F = 30\text{ A}, di_F/dt = -200\text{ A}/\mu\text{s}$ $V_R = 800\text{ V}$		320		
$Q_{rr}$	Reverse recovery charge			545		nC
$I_{RRM}$	Maximum reverse recovery current				4	
$t_{rr}$	Reverse recovery time	$I_F = 30\text{ A}, di_F/dt = -200\text{ A}/\mu\text{s}$ $V_R = 800\text{ V}, T_J = 125\text{ }^\circ\text{C}$		435		ns
$Q_{rr}$	Reverse recovery charge			2100		nC
$I_{RRM}$	Maximum reverse recovery current				9	
$t_{rr}$	Reverse recovery time	$I_F = 30\text{ A}, di_F/dt = -1000\text{ A}/\mu\text{s}$ $V_R = 800\text{ V}, T_J = 125\text{ }^\circ\text{C}$		180		ns
$Q_{rr}$	Reverse recovery charge			2975		nC
$I_{RRM}$	Maximum reverse recovery current				28	

## Typical Performance Curves

This section shows the typical performance curves of the APT30DQ120KG device.

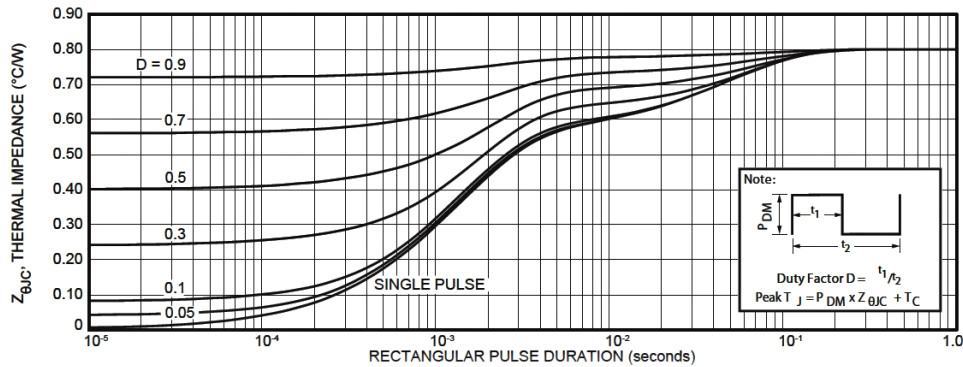

Figure 1 • Maximum Transient Thermal Impedance

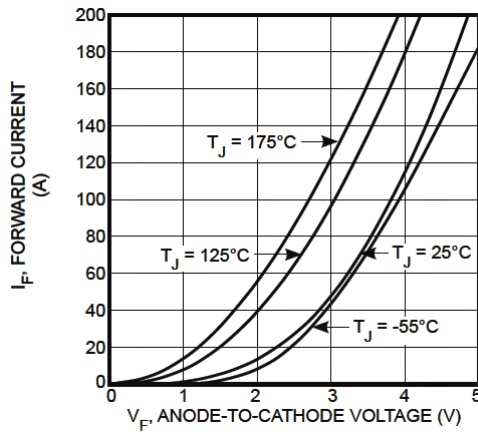

Figure 2 • Forward Current vs. Forward Voltage

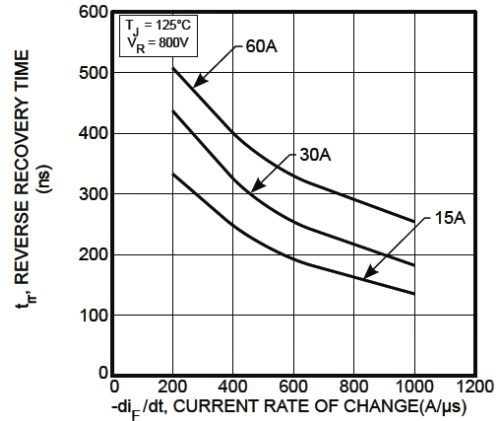

Figure 3 • Reverse Recovery Time vs. Current Rate of Change

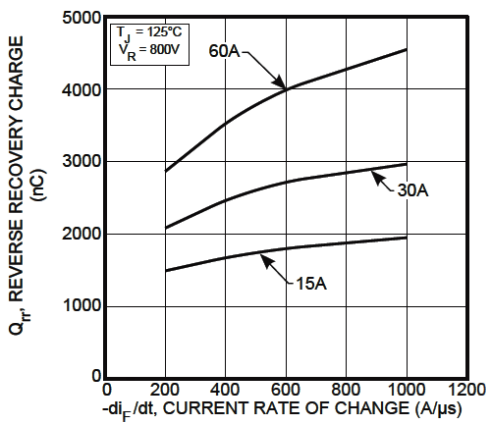

Figure 4 • Reverse Recovery Charge vs. Current Rate of Change

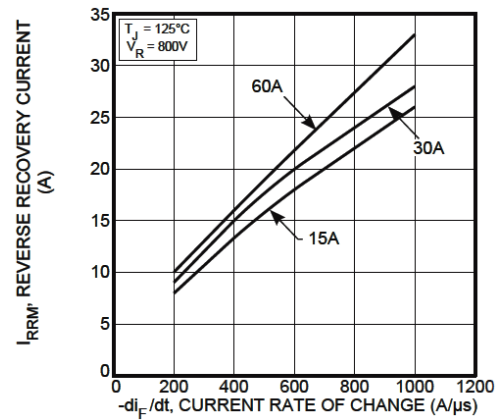

Figure 5 • Reverse Recovery Current vs. Current Rate of Change

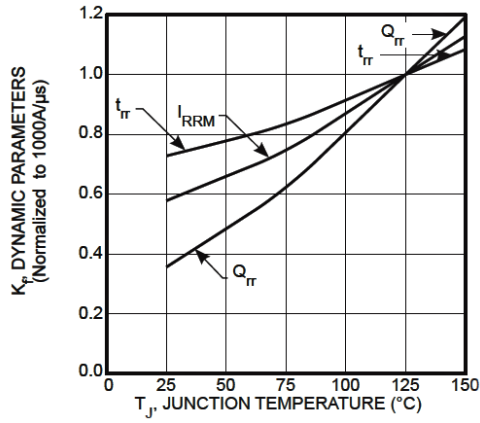

Figure 6 • Dynamic Parameters vs. Junction Temperature

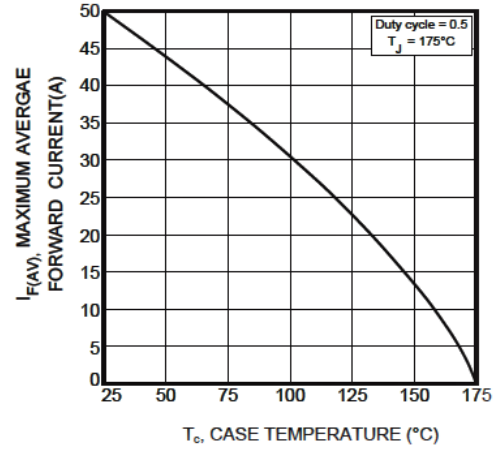

Figure 7 • Maximum Average Forward Current vs. Case Temperature

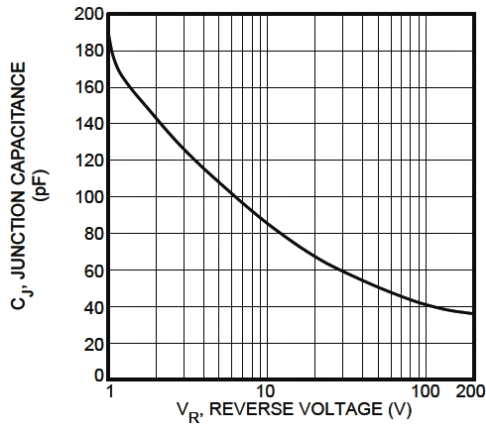
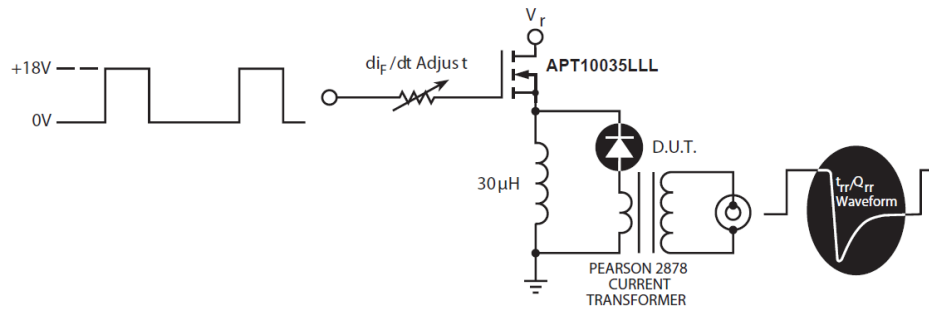

Figure 8 • Junction Capacitance vs. Reverse Voltage

## Reverse Recovery Overview

The following figure illustrates the diode test circuit of the APT30DQ120KG device.



**Figure 9 • Diode Test Circuit**

The following figure illustrates the diode reverse recovery waveform and definitions of the APT30DQ120KG device.

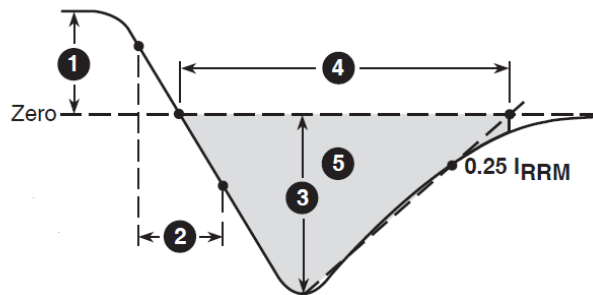

**Figure 10 • Diode Reverse Recovery Waveform and Definitions**

1.  $I_F$  — Forward conduction current
2.  $di_F/dt$  — Rate of diode current change through zero crossing
3.  $I_{RRM}$  — Maximum reverse recovery current
4.  $t_{rr}$  — Reverse recovery time, measured from zero crossing where diode current goes from positive to negative, to the point at which the straight line through  $I_{RRM}$  and  $0.25 \cdot I_{RRM}$  passes through zero
5.  $Q_{rr}$  — Area under the curve defined by  $I_{RRM}$  and  $t_{rr}$

## Package Specification

This section shows the package specification of the APT30DQ120KG device.

### Package Outline Drawing

The following figure illustrates the TO-220 package outline of the APT30DQ120KG device.

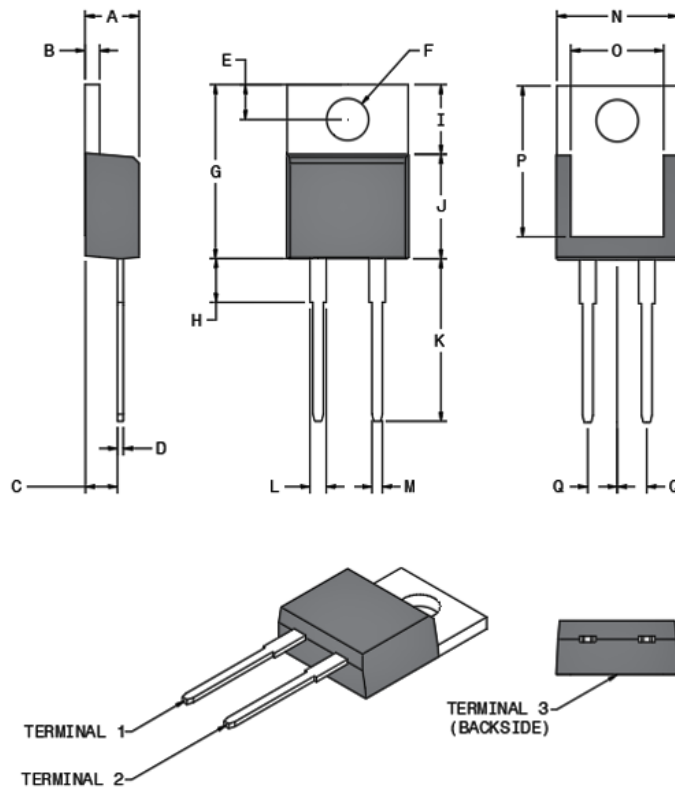

**Figure 11 • Package Outline Drawing**

The following table shows the TO-220 dimensions and should be used in conjunction with the package outline drawing.

**Table 5 • TO-220 Dimensions**

Symbol	Min	Max	Min	Max
	(mm)		(Inch)	
A	4.32	4.57	0.170	0.180
B	1.14	1.40	0.045	0.055
C	2.50	2.74	0.098	0.108
D	0.36	0.53	0.014	0.021

Symbol	Min	Max	Min	Max
	(mm)		(Inch)	
E	2.65	3.05	0.104	0.120
F	3.60	3.96	0.142	0.156
G	14.50	15.60	0.571	0.614
H	2.39	3.65	0.094	0.144
I	6.00	6.80	0.236	0.268
J	8.40	9.00	0.331	0.354
K	13.00	14.00	0.512	0.551
L	1.23	1.39	0.048	0.055
M	0.69	0.88	0.027	0.035
N	10.00	10.36	0.394	0.408
O	7.57	7.90	0.298	0.311
P	12.20	13.10	0.480	0.516
Q	2.54 BSC		0.100 BSC	
Terminal 1	CATHODE			
Terminal 2	ANODE			
Terminal 3	CATHODE			

**Microsemi**

2355 W. Chandler Blvd.  
 Chandler, AZ 85224 USA

Within the USA: +1 (480) 792-7200  
 Fax: +1 (480) 792-7277

www.microsemi.com © 2020 Microsemi and its corporate affiliates. All rights reserved. Microsemi and the Microsemi logo are trademarks of Microsemi Corporation and its corporate affiliates. All other trademarks and service marks are the property of their respective owners.

Microsemi's product warranty is set forth in Microsemi's Sales Order Terms and Conditions. Information contained in this publication is provided for the sole purpose of designing with and using Microsemi products. Information regarding device applications and the like is provided only for your convenience and may be superseded by updates. Buyer shall not rely on any data and performance specifications or parameters provided by Microsemi. It is your responsibility to ensure that your application meets with your specifications. THIS INFORMATION IS PROVIDED "AS IS." MICROSEMI MAKES NO REPRESENTATIONS OR WARRANTIES OF ANY KIND WHETHER EXPRESS OR IMPLIED, WRITTEN OR ORAL, STATUTORY OR OTHERWISE, RELATED TO THE INFORMATION, INCLUDING BUT NOT LIMITED TO ITS CONDITION, QUALITY, PERFORMANCE, NON-INFRINGEMENT, MERCHANTABILITY OR FITNESS FOR A PARTICULAR PURPOSE. IN NO EVENT WILL MICROSEMI BE LIABLE FOR ANY INDIRECT, SPECIAL, PUNITIVE, INCIDENTAL OR CONSEQUENTIAL LOSS, DAMAGE, COST OR EXPENSE WHATSOEVER RELATED TO THIS INFORMATION OR ITS USE, HOWEVER CAUSED, EVEN IF MICROSEMI HAS BEEN ADVISED OF THE POSSIBILITY OR THE DAMAGES ARE FORESEEABLE. TO THE FULLEST EXTENT ALLOWED BY LAW, MICROSEMI'S TOTAL LIABILITY ON ALL CLAIMS IN RELATED TO THIS INFORMATION OR ITS USE WILL NOT EXCEED THE AMOUNT OF FEES, IF ANY, YOU PAID DIRECTLY TO MICROSEMI FOR THIS INFORMATION. Use of Microsemi devices in life support, mission-critical equipment or applications, and/or safety applications is entirely at the buyer's risk, and the buyer agrees to defend and indemnify Microsemi from any and all damages, claims, suits, or expenses resulting from such use. No licenses are conveyed, implicitly or otherwise, under any Microsemi intellectual property rights unless otherwise stated.

Microsemi Corporation, a subsidiary of Microchip Technology Inc. (Nasdaq: MCHP), and its corporate affiliates are leading providers of smart, connected and secure embedded control solutions. Their easy-to-use development tools and comprehensive product portfolio enable customers to create optimal designs which reduce risk while lowering total system cost and time to market. These solutions serve more than 120,000 customers across the industrial, automotive, consumer, aerospace and defense, communications and computing markets. Headquartered in Chandler, Arizona, the company offers outstanding technical support along with dependable delivery and quality. Learn more at [www.microsemi.com](http://www.microsemi.com).

053-4246 | April 2020 | Released

## Looking for pricing, stock, or lifecycle information?

Click below to explore more details on WIN SOURCE:

- ⊖ [View APT30DQ120KG](#) on WIN SOURCE
- ⊖ [Microchip Technology](#) Information

## Optimize Your Supply Chain with WIN SOURCE Solutions

- ✓ Global Sourcing Solution
- ✓ Obsolete Management
- ✓ Cost Control Management
- ✓ Shortage Management
- ✓ Alternative Solution
- ✓ Excess Inventory Management