



**THE DATASHEET OF  
SNJ54S112J**



# SN54LS112A, SN54S112, SN74LS112A, SN74S112A DUAL J-K NEGATIVE-EDGE-TRIGGERED FLIP-FLOPS WITH PRESET AND CLEAR

D2661, APRIL 1982—REVISED MARCH 1988

SDLS011

- Fully Buffered to Offer Maximum Isolation from External Disturbance
- Package Options Include Plastic "Small Outline" Packages, Ceramic Chip Carriers and Flat Packages, and Plastic and Ceramic DIPs
- Dependable Texas Instruments Quality and Reliability

## description

These devices contain two independent J-K negative-edge-triggered flip-flops. A low level at the preset and clear inputs sets or resets the outputs regardless of the levels of the other inputs. When preset and clear are inactive (high), data at the J and K inputs meeting the setup time requirements are transferred to the outputs on the negative-going edge of the clock pulse. Clock triggering occurs at a voltage level and is not directly related to the rise time of the clock pulse. Following the hold time interval, data at the J and K inputs may be changed without affecting the levels at the outputs. These versatile flip-flops can perform as toggle flip-flops by tying J and K high.

The SN54LS112A and SN54S112 are characterized for operation over the full military temperature range of  $-55^{\circ}\text{C}$  to  $125^{\circ}\text{C}$ . The SN74LS112A and SN74S112A are characterized for operation from  $0^{\circ}\text{C}$  to  $70^{\circ}\text{C}$ .

FUNCTION TABLE (each flip-flop)

INPUTS					OUTPUTS	
PRE	CLR	CLK	J	K	Q	$\bar{Q}$
L	H	X	X	X	H	L
H	L	X	X	X	L	H
L	L	X	X	X	H <sup>†</sup>	H <sup>†</sup>
H	H	↓	L	L	Q <sub>0</sub>	$\bar{Q}_0$
H	H	↓	H	L	H	L
H	H	↓	L	H	L	H
H	H	↓	H	H	TOGGLE	TOGGLE
H	H	H	X	X	Q <sub>0</sub>	$\bar{Q}_0$

<sup>†</sup> The output levels in this configuration are not guaranteed to meet the minimum levels for  $V_{OH}$  if the lows at preset and clear are near  $V_{IL}$  minimum. Furthermore, this configuration is nonstable; that is, it will not persist when either preset or clear returns to its inactive (high) level.

SN54LS112A, SN54S112 . . . J OR W PACKAGE  
SN74LS112A, SN74S112A . . . D OR N PACKAGE

(TOP VIEW)

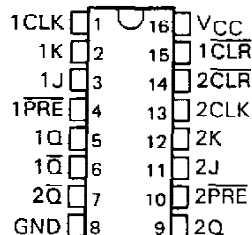

SN54LS112A, SN54S112 . . . FK PACKAGE

(TOP VIEW)

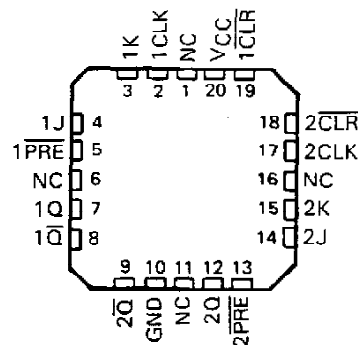

NC—No internal connection

## logic symbol<sup>†</sup>

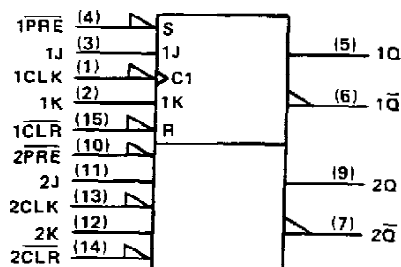

<sup>†</sup>This symbol is in accordance with ANSI/IEEE Std 91-1984 and IEC Publication 617-12.

Pin numbers shown are for D, J, N, and W packages.

PRODUCTION DATA documents contain information current as of publication date. Products conform to specifications per the terms of Texas Instruments standard warranty. Production processing does not necessarily include testing of all parameters.

TEXAS  
INSTRUMENTS

POST OFFICE BOX 655012 • DALLAS, TEXAS 75265

Copyright © 1982, Texas Instruments Incorporated

**SN54LS112A, SN54S112, SN74LS112A, SN74S112A**  
**DUAL J-K NEGATIVE-EDGE-TRIGGERED**  
**FLIP-FLOPS WITH PRESET AND CLEAR**

logic diagrams (positive logic)

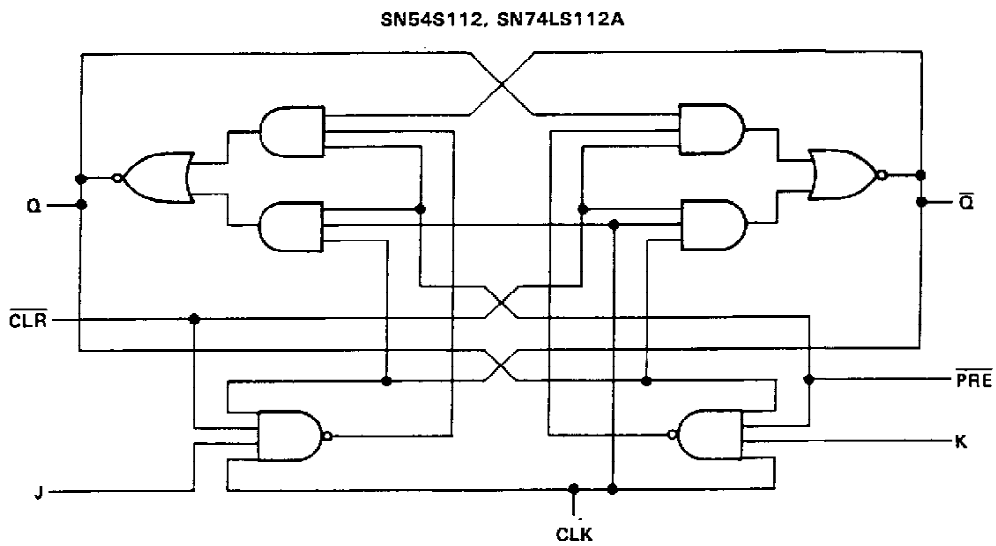
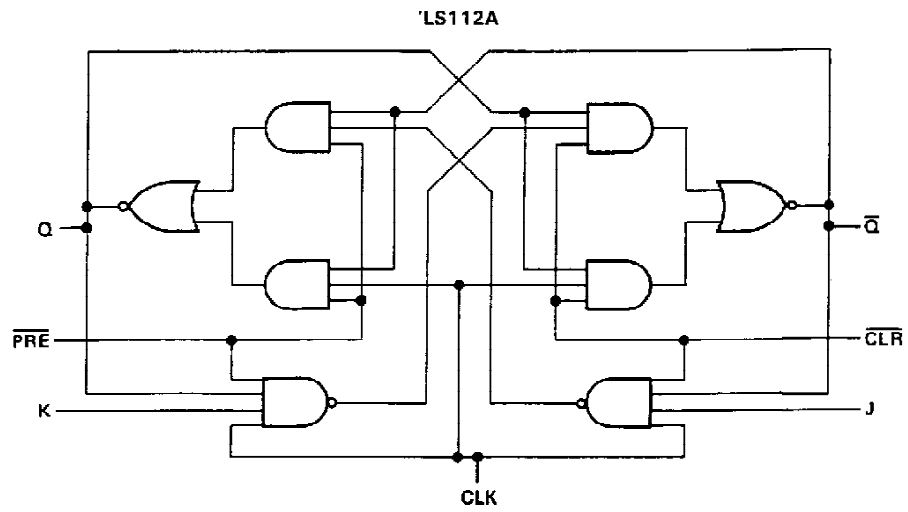

**SN54LS112A, SN54S112, SN74LS112A, SN74S112A**  
**DUAL J-K NEGATIVE-EDGE-TRIGGERED**  
**FLIP-FLOPS WITH PRESET AND CLEAR**

schematics of inputs and outputs

'LS112A

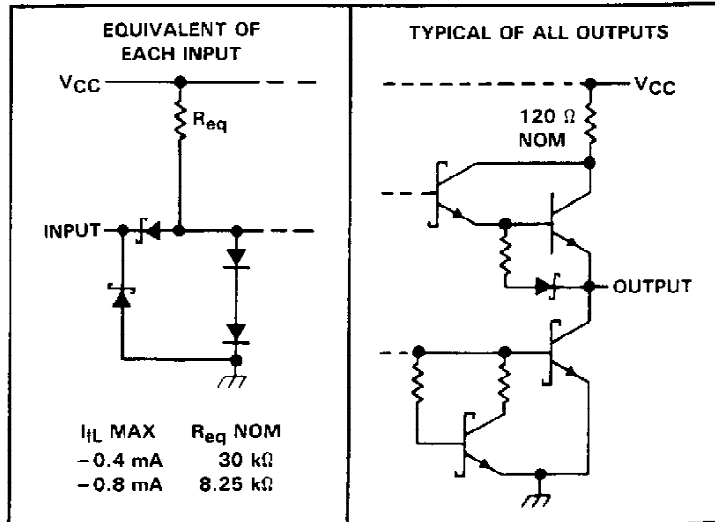

SN54S112, SN74S112A

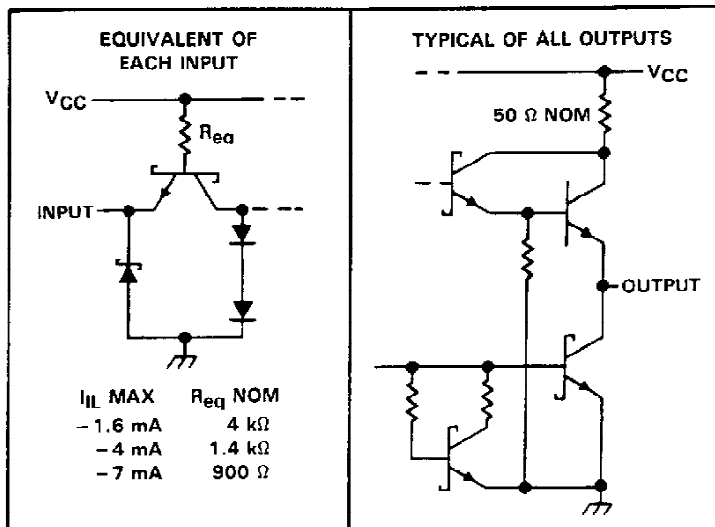

absolute maximum ratings over operating free-air temperature range (unless otherwise noted)

Supply voltage, $V_{CC}$ (see Note 1) .....	7 V
Input voltage: 'LS112A .....	7 V
SN54LS112, SN74LS112A .....	5.5 V
Operating free-air temperature range: SN54' .....	-55°C to 125°C
SN74' .....	0°C to 70°C
Storage temperature range .....	-65°C to 150°C

NOTE 1: Voltage values are with respect to network ground terminal.

  
**TEXAS**  
**INSTRUMENTS**

POST OFFICE BOX 655012 • DALLAS, TEXAS 75265

# SN54LS112A, SN74LS112A

## DUAL J-K NEGATIVE-EDGE-TRIGGERED FLIP-FLOPS WITH PRESET AND CLEAR

### recommended operating conditions

		SN54LS112A			SN74LS112A			UNIT
		MIN	NOM	MAX	MIN	NOM	MAX	
$V_{CC}$	Supply voltage	4.5	5	5.5	4.75	5	5.25	V
$V_{IH}$	High-level input voltage	2			2			V
$V_{IL}$	Low-level input voltage			0.7			0.8	V
$I_{OH}$	High-level output current			-0.4			-0.4	mA
$I_{OL}$	Low-level output current			4			8	mA
$f_{clock}$	Clock frequency	0		30	0		30	MHz
$t_w$	Pulse duration	CLK high		20			20	ns
		PRE or CLR low		25			25	
$t_{su}$	Set up time-before CLK↓	Data high or low		20			20	ns
		CLR inactive		25			25	
		PRE inactive		20			20	
$t_h$	Hold time-data after CLK↓	0			0			ns
$T_A$	Operating free-air temperature	-55		125	0		70	°C

### electrical characteristics over recommended operating free-air temperature range (unless otherwise noted)

PARAMETER		TEST CONDITIONS†		SN54LS112A			SN74LS112A			UNIT
				MIN	TYP‡	MAX	MIN	TYP‡	MAX	
$V_{IK}$		$V_{CC} = \text{MIN}$ ,	$I_I = -18 \text{ mA}$			-1.5			-1.5	V
$V_{OH}$		$V_{CC} = \text{MIN}$ ,	$V_{IH} = 2 \text{ V}$ , $V_{IL} = \text{MAX}$ ,	2.5	3.4		2.7	3.4		V
$V_{OL}$		$V_{CC} = \text{MIN}$ ,	$V_{IL} = \text{MAX}$ , $V_{IH} = 2 \text{ V}$ ,	0.25	0.4		0.25	0.4		V
		$V_{CC} = \text{MIN}$ ,	$V_{IL} = \text{MAX}$ , $V_{IH} = 2 \text{ V}$ ,				0.35	0.5		
$I_I$	J or K	$V_{CC} = \text{MAX}$ ,	$V_I = 7 \text{ V}$			0.1			0.1	mA
	CLR or PRE					0.3			0.3	
	CLK					0.4			0.4	
$I_{IH}$	J or K	$V_{CC} = \text{MAX}$ ,	$V_I = 2.7 \text{ V}$			20			20	$\mu\text{A}$
	CLR or PRE					60			60	
	CLK					80			80	
$I_{IL}$	J or K	$V_{CC} = \text{MAX}$ ,	$V_I = 0.4 \text{ V}$			-0.4			-0.4	mA
	All other					-0.8			-0.8	
$I_{OS}^{\S}$		$V_{CC} = \text{MAX}$ ,	see Note 2	-20	-100		-20	-100		mA
$I_{CC}$ (Total)		$V_{CC} = \text{MAX}$ ,	see Note 3	4	6		4	6		mA

† For conditions shown as MIN or MAX, use the appropriate value specified under recommended operating conditions.

‡ All typical values are at  $V_{CC} = 5 \text{ V}$ ,  $T_A = 25^\circ\text{C}$ .

§ Not more than one output should be shorted at a time, and the duration of the short-circuit should not exceed one second.

NOTES: 2. For certain devices where state commutation can be caused by shorting an output to ground, an equivalent test may be performed with  $V_O = 2.25 \text{ V}$  and  $2.125 \text{ V}$  for the '54 family and the '74 family, respectively, with the minimum and maximum limits reduced to one half of their stated values.

3. With all outputs open,  $I_{CC}$  is measured with the Q and  $\bar{Q}$  outputs high in turn. At the time of measurement, the clock input is grounded.

TEXAS  
INSTRUMENTS

POST OFFICE BOX 655012 • DALLAS, TEXAS 75265

**SN54LS112A, SN74LS112A**  
**DUAL J-K NEGATIVE-EDGE-TRIGGERED**  
**FLIP-FLOPS WITH PRESET AND CLEAR**

switching characteristics,  $V_{CC} = 5\text{ V}$ ,  $T_A = 25^\circ\text{C}$  (see Note 4)

PARAMETER	FROM (INPUT)	TO (OUTPUT)	TEST CONDITIONS	MIN	TYP	MAX	UNIT	
$f_{\max}$			$R_L = 2\text{ k}\Omega$ , $C_L = 15\text{ pF}$	30	45		MHz	
$t_{PLH}$	$\overline{\text{CLR}}$ , $\overline{\text{PRE}}$ or CLK	Q or $\overline{\text{Q}}$			15	20		ns
$t_{PHL}$					15	20		ns

NOTE 4: Load circuits and voltage waveforms are shown in Section 1.

**SN54S112, SN74S112A**  
**DUAL J-K NEGATIVE-EDGE-TRIGGERED**  
**FLIP-FLOPS WITH PRESET AND CLEAR**

**recommended operating conditions**

		SN54S112			SN74S112A			UNIT
		MIN	NOM	MAX	MIN	NOM	MAX	
V <sub>CC</sub>	Supply voltage	4.5	5	5.5	4.75	5	5.25	V
V <sub>IH</sub>	High-level input voltage	2			2			V
V <sub>IL</sub>	Low-level input voltage				0.8			V
I <sub>OH</sub>	High-level output current				-1			mA
I <sub>OL</sub>	Low-level output current				20			mA
t <sub>w</sub>	Pulse duration	CLK high		6	6		ns	
		CLK low		6.5	6.5			
		PRE or CLR low		8	8			
t <sub>su</sub>	Set up time-before CLK↓	Data high or low		7	7		ns	
t <sub>h</sub>	Hold time-data after CLK↓	0			0			ns
T <sub>A</sub>	Operating free-air temperature	-55		125	0		70	°C

**electrical characteristics over recommended operating free-air temperature range (unless otherwise noted)**

PARAMETER		TEST CONDITIONS†		SN54S112			SN74S112A			UNIT
				MIN	TYP‡	MAX	MIN	TYP‡	MAX	
V <sub>IK</sub>		V <sub>CC</sub> = MIN, I <sub>I</sub> = -18 mA		-1.2			-1.2			V
V <sub>OH</sub>		V <sub>CC</sub> = MIN, I <sub>OH</sub> = -1 mA, V <sub>IH</sub> = 2 V, V <sub>IL</sub> = MAX,		2.5	3.4		2.7	3.4		V
V <sub>OL</sub>		V <sub>CC</sub> = MIN, I <sub>OL</sub> = 20 mA, V <sub>IH</sub> = 2 V, V <sub>IL</sub> = 0.8 V,		0.5			0.5			V
I <sub>I</sub>		V <sub>CC</sub> = MAX, V <sub>I</sub> = 5.5 V		1			1			mA
I <sub>IH</sub>	J or K	V <sub>CC</sub> = MAX, V <sub>I</sub> = 2.7 V		50			50			μA
	All other			100			100			
I <sub>IL</sub>	J or K	V <sub>CC</sub> = MAX, V <sub>I</sub> = 0.5 V		-1.6			-1.6			mA
	CLR‡			-7			-7			
	PRE‡			-7			-7			
	CLK			-4			-4			
I <sub>OS</sub> †		V <sub>CC</sub> = MAX		-40	-100		-40	-100	mA	
I <sub>CC</sub> #		V <sub>CC</sub> = MAX, see Note 3		15	25		15	25	mA	

† For conditions shown as MIN or MAX, use the appropriate value specified under recommended operating conditions.

‡ All typical values are at V<sub>CC</sub> = 5 V, T<sub>A</sub> = 25°C.

§ Clear is tested with preset high and preset is tested with clear high.

¶ Not more than one output should be shorted at a time, and the duration of the short-circuit should not exceed one second.

# Values are average per flip-flop.

NOTE 3: With all outputs open, I<sub>CC</sub> is measured with the Q and Q̄ outputs high in turn. At the time of measurement, the clock input is grounded.



**SN54S112, SN74S112A**  
**DUAL J-K NEGATIVE-EDGE-TRIGGERED**  
**FLIP-FLOPS WITH PRESET AND CLEAR**

switching characteristics,  $V_{CC} = 5\text{ V}$ ,  $T_A = 25^\circ\text{C}$  (see Note 4)

PARAMETER	FROM (INPUT)	TO (OUTPUT)	TEST CONDITIONS	MIN	TYP	MAX	UNIT
$f_{max}$			$R_L = 280\ \Omega, \quad C_L = 15\ \text{pF}$	80	125		MHz
$t_{PLH}$	$\overline{\text{PRE}}$ or $\overline{\text{CLR}}$	$Q$ or $\overline{Q}$			4	7	ns
$t_{PHL}$	$\overline{\text{PRE}}$ or $\overline{\text{CLR}}$ (CLK high)	$\overline{Q}$ or $Q$			5	7	ns
	$\overline{\text{PRE}}$ or $\overline{\text{CLR}}$ (CLK low)				5	7	
$t_{PLH}$	CLK	$Q$ or $\overline{Q}$			4	7	ns
$t_{PHL}$					5	7	ns

NOTE 4: Load circuits and voltage waveforms are shown in Section 1.

**PACKAGING INFORMATION**

Orderable Device	Status (1)	Package Type	Package Drawing	Pins	Package Qty	Eco Plan (2)	Lead finish/ Ball material (6)	MSL Peak Temp (3)	Op Temp (°C)	Device Marking (4/5)	Samples
JM38510/07102BEA	ACTIVE	CDIP	J	16	25	Non-RoHS & Green	SNPB	N / A for Pkg Type	-55 to 125	JM38510/07102B EA	<a href="#">Samples</a>
JM38510/07102BFA	ACTIVE	CFP	W	16	25	Non-RoHS & Green	SNPB	N / A for Pkg Type	-55 to 125	JM38510/ 07102BFA	<a href="#">Samples</a>
JM38510/30103B2A	ACTIVE	LCCC	FK	20	55	Non-RoHS & Green	SNPB	N / A for Pkg Type	-55 to 125	JM38510/ 30103B2A	<a href="#">Samples</a>
JM38510/30103BEA	ACTIVE	CDIP	J	16	25	Non-RoHS & Green	SNPB	N / A for Pkg Type	-55 to 125	JM38510/ 30103BEA	<a href="#">Samples</a>
JM38510/30103BFA	ACTIVE	CFP	W	16	25	Non-RoHS & Green	SNPB	N / A for Pkg Type	-55 to 125	JM38510/ 30103BFA	<a href="#">Samples</a>
M38510/07102BEA	ACTIVE	CDIP	J	16	25	Non-RoHS & Green	SNPB	N / A for Pkg Type	-55 to 125	JM38510/07102B EA	<a href="#">Samples</a>
M38510/07102BFA	ACTIVE	CFP	W	16	25	Non-RoHS & Green	SNPB	N / A for Pkg Type	-55 to 125	JM38510/ 07102BFA	<a href="#">Samples</a>
M38510/30103B2A	ACTIVE	LCCC	FK	20	55	Non-RoHS & Green	SNPB	N / A for Pkg Type	-55 to 125	JM38510/ 30103B2A	<a href="#">Samples</a>
M38510/30103BEA	ACTIVE	CDIP	J	16	25	Non-RoHS & Green	SNPB	N / A for Pkg Type	-55 to 125	JM38510/ 30103BEA	<a href="#">Samples</a>
M38510/30103BFA	ACTIVE	CFP	W	16	25	Non-RoHS & Green	SNPB	N / A for Pkg Type	-55 to 125	JM38510/ 30103BFA	<a href="#">Samples</a>
SN54LS112AJ	ACTIVE	CDIP	J	16	25	Non-RoHS & Green	SNPB	N / A for Pkg Type	-55 to 125	SN54LS112AJ	<a href="#">Samples</a>
SN54S112J	ACTIVE	CDIP	J	16	25	Non-RoHS & Green	SNPB	N / A for Pkg Type	-55 to 125	SN54S112J	<a href="#">Samples</a>
SN74LS112ADR	ACTIVE	SOIC	D	16	2500	RoHS & Green	NIPDAU	Level-1-260C-UNLIM	0 to 70	LS112A	<a href="#">Samples</a>
SN74LS112AN	ACTIVE	PDIP	N	16	25	RoHS & Green	NIPDAU	N / A for Pkg Type	0 to 70	SN74LS112AN	<a href="#">Samples</a>
SN74LS112ANSR	ACTIVE	SO	NS	16	2000	RoHS & Green	NIPDAU	Level-1-260C-UNLIM	0 to 70	74LS112A	<a href="#">Samples</a>
SN74S112AN	ACTIVE	PDIP	N	16	25	RoHS & Green	NIPDAU	N / A for Pkg Type	0 to 70	SN74S112AN	<a href="#">Samples</a>
SNJ54LS112AFK	ACTIVE	LCCC	FK	20	55	Non-RoHS & Green	SNPB	N / A for Pkg Type	-55 to 125	SNJ54LS 112AFK	<a href="#">Samples</a>

Orderable Device	Status (1)	Package Type	Package Drawing	Pins	Package Qty	Eco Plan (2)	Lead finish/ Ball material (6)	MSL Peak Temp (3)	Op Temp (°C)	Device Marking (4/5)	Samples
SNJ54LS112AJ	ACTIVE	CDIP	J	16	25	Non-RoHS & Green	SNPB	N / A for Pkg Type	-55 to 125	SNJ54LS112AJ	<a href="#">Samples</a>
SNJ54LS112AW	ACTIVE	CFP	W	16	25	Non-RoHS & Green	SNPB	N / A for Pkg Type	-55 to 125	SNJ54LS112AW	<a href="#">Samples</a>
SNJ54S112FK	ACTIVE	LCCC	FK	20	55	Non-RoHS & Green	SNPB	N / A for Pkg Type	-55 to 125	SNJ54S 112FK	<a href="#">Samples</a>
SNJ54S112J	ACTIVE	CDIP	J	16	25	Non-RoHS & Green	SNPB	N / A for Pkg Type	-55 to 125	SNJ54S112J	<a href="#">Samples</a>
SNJ54S112W	ACTIVE	CFP	W	16	25	Non-RoHS & Green	SNPB	N / A for Pkg Type	-55 to 125	SNJ54S112W	<a href="#">Samples</a>

(1) The marketing status values are defined as follows:

**ACTIVE:** Product device recommended for new designs.

**LIFEBUY:** TI has announced that the device will be discontinued, and a lifetime-buy period is in effect.

**NRND:** Not recommended for new designs. Device is in production to support existing customers, but TI does not recommend using this part in a new design.

**PREVIEW:** Device has been announced but is not in production. Samples may or may not be available.

**OBSELETE:** TI has discontinued the production of the device.

(2) **RoHS:** TI defines "RoHS" to mean semiconductor products that are compliant with the current EU RoHS requirements for all 10 RoHS substances, including the requirement that RoHS substance do not exceed 0.1% by weight in homogeneous materials. Where designed to be soldered at high temperatures, "RoHS" products are suitable for use in specified lead-free processes. TI may reference these types of products as "Pb-Free".

**RoHS Exempt:** TI defines "RoHS Exempt" to mean products that contain lead but are compliant with EU RoHS pursuant to a specific EU RoHS exemption.

**Green:** TI defines "Green" to mean the content of Chlorine (Cl) and Bromine (Br) based flame retardants meet JS709B low halogen requirements of <=1000ppm threshold. Antimony trioxide based flame retardants must also meet the <=1000ppm threshold requirement.

(3) MSL, Peak Temp. - The Moisture Sensitivity Level rating according to the JEDEC industry standard classifications, and peak solder temperature.

(4) There may be additional marking, which relates to the logo, the lot trace code information, or the environmental category on the device.

(5) Multiple Device Markings will be inside parentheses. Only one Device Marking contained in parentheses and separated by a "~" will appear on a device. If a line is indented then it is a continuation of the previous line and the two combined represent the entire Device Marking for that device.

(6) Lead finish/Ball material - Orderable Devices may have multiple material finish options. Finish options are separated by a vertical ruled line. Lead finish/Ball material values may wrap to two lines if the finish value exceeds the maximum column width.

**Important Information and Disclaimer:**The information provided on this page represents TI's knowledge and belief as of the date that it is provided. TI bases its knowledge and belief on information provided by third parties, and makes no representation or warranty as to the accuracy of such information. Efforts are underway to better integrate information from third parties. TI has taken and continues to take reasonable steps to provide representative and accurate information but may not have conducted destructive testing or chemical analysis on incoming materials and chemicals. TI and TI suppliers consider certain information to be proprietary, and thus CAS numbers and other limited information may not be available for release.

In no event shall TI's liability arising out of such information exceed the total purchase price of the TI part(s) at issue in this document sold by TI to Customer on an annual basis.

**OTHER QUALIFIED VERSIONS OF SN54LS112A, SN74LS112A :**

- Catalog : [SN74LS112A](#)
- Military : [SN54LS112A](#)

NOTE: Qualified Version Definitions:

- Catalog - TI's standard catalog product
- Military - QML certified for Military and Defense Applications

**TAPE AND REEL INFORMATION**

**QUADRANT ASSIGNMENTS FOR PIN 1 ORIENTATION IN TAPE**



\*All dimensions are nominal

Device	Package Type	Package Drawing	Pins	SPQ	Reel Diameter (mm)	Reel Width W1 (mm)	A0 (mm)	B0 (mm)	K0 (mm)	P1 (mm)	W (mm)	Pin1 Quadrant
SN74LS112ADR	SOIC	D	16	2500	330.0	16.4	6.5	10.3	2.1	8.0	16.0	Q1
SN74LS112ANSR	SO	NS	16	2000	330.0	16.4	8.2	10.5	2.5	12.0	16.0	Q1

**TAPE AND REEL BOX DIMENSIONS**

\*All dimensions are nominal

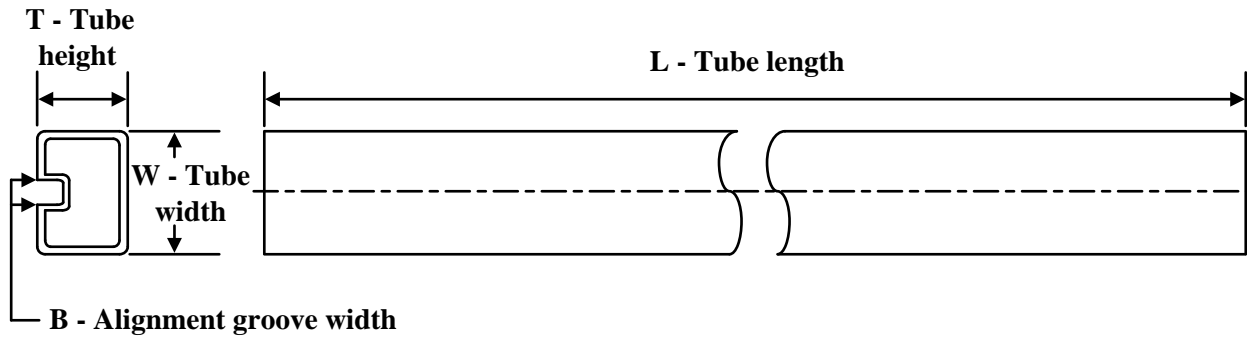
Device	Package Type	Package Drawing	Pins	SPQ	Length (mm)	Width (mm)	Height (mm)
SN74LS112ADR	SOIC	D	16	2500	340.5	336.1	32.0
SN74LS112ANSR	SO	NS	16	2000	356.0	356.0	35.0

**TUBE**

\*All dimensions are nominal

Device	Package Name	Package Type	Pins	SPQ	L (mm)	W (mm)	T (μm)	B (mm)
JM38510/07102BFA	W	CFP	16	25	506.98	26.16	6220	NA
JM38510/30103B2A	FK	LCCC	20	55	506.98	12.06	2030	NA
JM38510/30103BFA	W	CFP	16	25	506.98	26.16	6220	NA
M38510/07102BFA	W	CFP	16	25	506.98	26.16	6220	NA
M38510/30103B2A	FK	LCCC	20	55	506.98	12.06	2030	NA
M38510/30103BFA	W	CFP	16	25	506.98	26.16	6220	NA
SN74LS112AN	N	PDIP	16	25	506	13.97	11230	4.32
SN74LS112AN	N	PDIP	16	25	506	13.97	11230	4.32
SN74S112AN	N	PDIP	16	25	506	13.97	11230	4.32
SN74S112AN	N	PDIP	16	25	506	13.97	11230	4.32
SNJ54LS112AFK	FK	LCCC	20	55	506.98	12.06	2030	NA
SNJ54LS112AW	W	CFP	16	25	506.98	26.16	6220	NA
SNJ54S112FK	FK	LCCC	20	55	506.98	12.06	2030	NA

D (R-PDSO-G16)

PLASTIC SMALL OUTLINE



4040047-6/M 06/11

- NOTES:
- A. All linear dimensions are in inches (millimeters).
  - B. This drawing is subject to change without notice.
  -  C. Body length does not include mold flash, protrusions, or gate burrs. Mold flash, protrusions, or gate burrs shall not exceed 0.006 (0,15) each side.
  -  D. Body width does not include interlead flash. Interlead flash shall not exceed 0.017 (0,43) each side.
  - E. Reference JEDEC MS-012 variation AC.

D (R-PDSO-G16)

PLASTIC SMALL OUTLINE



- NOTES:
- All linear dimensions are in millimeters.
  - This drawing is subject to change without notice.
  - Publication IPC-7351 is recommended for alternate designs.
  - Laser cutting apertures with trapezoidal walls and also rounding corners will offer better paste release. Customers should contact their board assembly site for stencil design recommendations. Refer to IPC-7525 for other stencil recommendations.
  - Customers should contact their board fabrication site for solder mask tolerances between and around signal pads.

# MECHANICAL DATA

NS (R-PDSO-G\*\*)

PLASTIC SMALL-OUTLINE PACKAGE

14-PINS SHOWN



- NOTES:
- A. All linear dimensions are in millimeters.
  - B. This drawing is subject to change without notice.
  - C. Body dimensions do not include mold flash or protrusion, not to exceed 0,15.

W (R-GDFP-F16)

CERAMIC DUAL FLATPACK

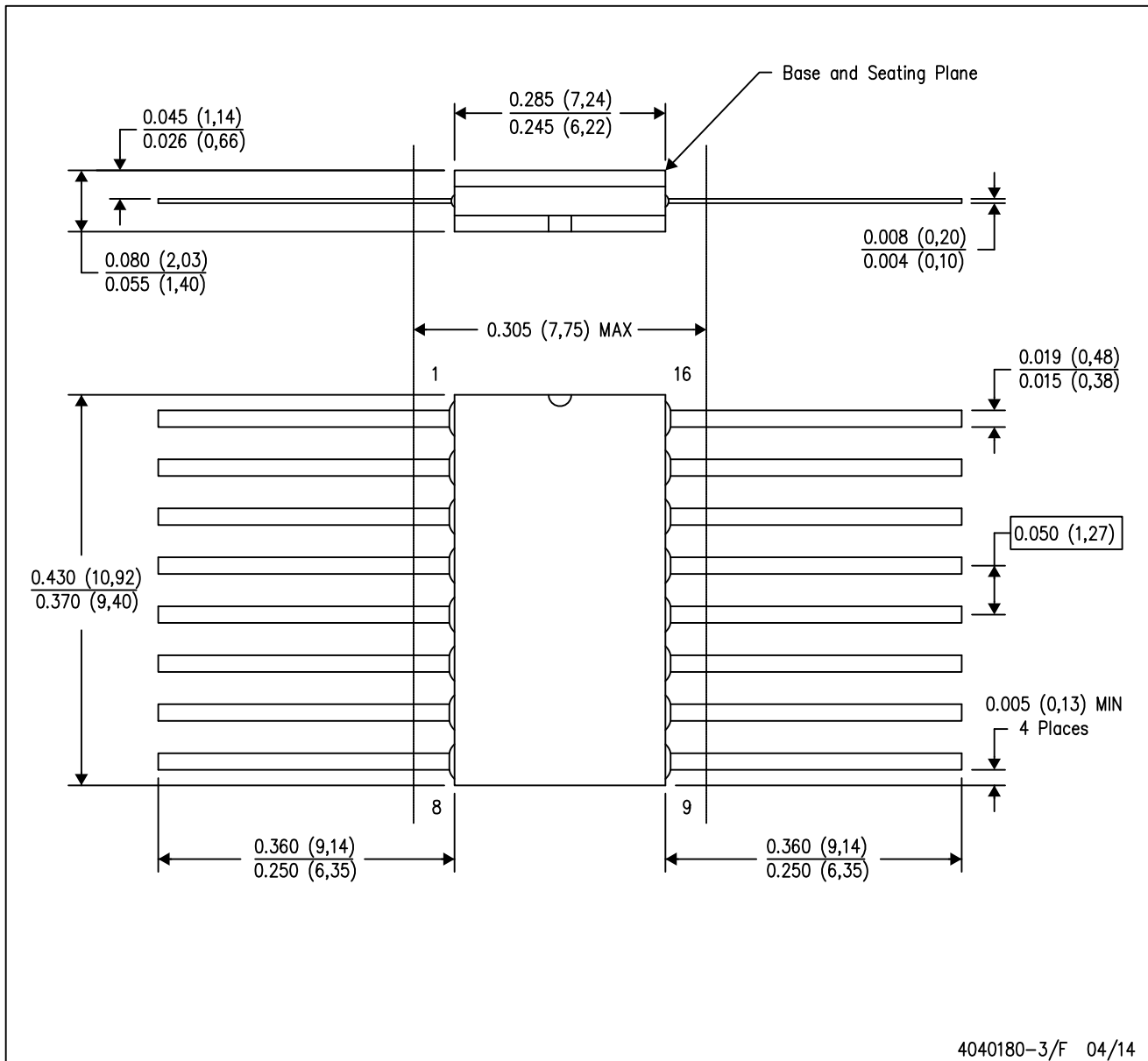

- NOTES:
- A. All linear dimensions are in inches (millimeters).
  - B. This drawing is subject to change without notice.
  - C. This package can be hermetically sealed with a ceramic lid using glass frit.
  - D. Index point is provided on cap for terminal identification only.
  - E. Falls within MIL STD 1835 GDFP2-F16

## GENERIC PACKAGE VIEW

**FK 20**

**LCCC - 2.03 mm max height**

8.89 x 8.89, 1.27 mm pitch

LEADLESS CERAMIC CHIP CARRIER

This image is a representation of the package family, actual package may vary.  
Refer to the product data sheet for package details.

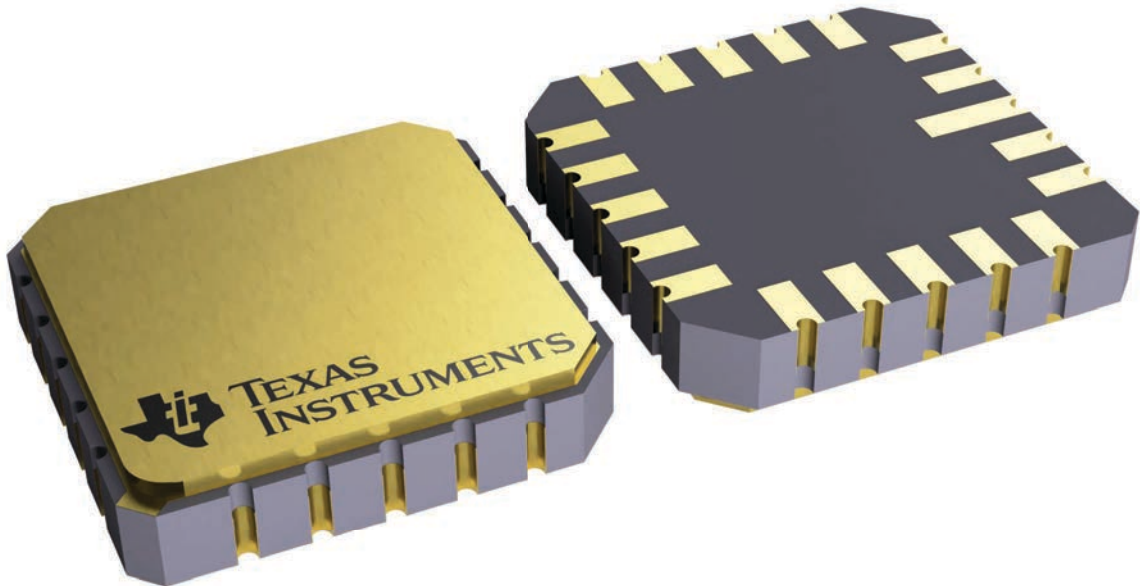

4229370VA\

J (R-GDIP-T\*\*)

14 LEADS SHOWN

CERAMIC DUAL IN-LINE PACKAGE



DIM \ PINS **	14	16	18	20
A	0.300 (7,62) BSC	0.300 (7,62) BSC	0.300 (7,62) BSC	0.300 (7,62) BSC
B MAX	0.785 (19,94)	.840 (21,34)	0.960 (24,38)	1.060 (26,92)
B MIN	—	—	—	—
C MAX	0.300 (7,62)	0.300 (7,62)	0.310 (7,87)	0.300 (7,62)
C MIN	0.245 (6,22)	0.245 (6,22)	0.220 (5,59)	0.245 (6,22)



4040083/F 03/03

- NOTES:
- A. All linear dimensions are in inches (millimeters).
  - B. This drawing is subject to change without notice.
  - C. This package is hermetically sealed with a ceramic lid using glass frit.
  - D. Index point is provided on cap for terminal identification only on press ceramic glass frit seal only.
  - E. Falls within MIL STD 1835 GDIP1-T14, GDIP1-T16, GDIP1-T18 and GDIP1-T20.

N (R-PDIP-T\*\*)

PLASTIC DUAL-IN-LINE PACKAGE

16 PINS SHOWN



4040049/E 12/2002

- NOTES:
- A. All linear dimensions are in inches (millimeters).
  - B. This drawing is subject to change without notice.
  - (C) Falls within JEDEC MS-001, except 18 and 20 pin minimum body length (Dim A).
  - (D) The 20 pin end lead shoulder width is a vendor option, either half or full width.



# PACKAGE OUTLINE

## NS0016A

### SOP - 2.00 mm max height

SOP



4220735/A 12/2021

#### NOTES:

1. All linear dimensions are in millimeters. Dimensions in parenthesis are for reference only. Dimensioning and tolerancing per ASME Y14.5M.
2. This drawing is subject to change without notice.
3. This dimension does not include mold flash, protrusions, or gate burrs. Mold flash, protrusions, or gate burrs shall not exceed 0.15 mm, per side.
4. This dimension does not include interlead flash. Interlead flash shall not exceed 0.25 mm, per side.

# EXAMPLE BOARD LAYOUT

NS0016A

SOP - 2.00 mm max height

SOP



4220735/A 12/2021

NOTES: (continued)

5. Publication IPC-7351 may have alternate designs.

6. Solder mask tolerances between and around signal pads can vary based on board fabrication site.

# EXAMPLE STENCIL DESIGN

NS0016A

SOP - 2.00 mm max height

SOP



SOLDER PASTE EXAMPLE  
BASED ON 0.125 mm THICK STENCIL  
SCALE:7X

4220735/A 12/2021

NOTES: (continued)

7. Laser cutting apertures with trapezoidal walls and rounded corners may offer better paste release. IPC-7525 may have alternate design recommendations.
8. Board assembly site may have different recommendations for stencil design.

## IMPORTANT NOTICE AND DISCLAIMER

TI PROVIDES TECHNICAL AND RELIABILITY DATA (INCLUDING DATA SHEETS), DESIGN RESOURCES (INCLUDING REFERENCE DESIGNS), APPLICATION OR OTHER DESIGN ADVICE, WEB TOOLS, SAFETY INFORMATION, AND OTHER RESOURCES "AS IS" AND WITH ALL FAULTS, AND DISCLAIMS ALL WARRANTIES, EXPRESS AND IMPLIED, INCLUDING WITHOUT LIMITATION ANY IMPLIED WARRANTIES OF MERCHANTABILITY, FITNESS FOR A PARTICULAR PURPOSE OR NON-INFRINGEMENT OF THIRD PARTY INTELLECTUAL PROPERTY RIGHTS.

These resources are intended for skilled developers designing with TI products. You are solely responsible for (1) selecting the appropriate TI products for your application, (2) designing, validating and testing your application, and (3) ensuring your application meets applicable standards, and any other safety, security, regulatory or other requirements.

These resources are subject to change without notice. TI grants you permission to use these resources only for development of an application that uses the TI products described in the resource. Other reproduction and display of these resources is prohibited. No license is granted to any other TI intellectual property right or to any third party intellectual property right. TI disclaims responsibility for, and you will fully indemnify TI and its representatives against, any claims, damages, costs, losses, and liabilities arising out of your use of these resources.

TI's products are provided subject to [TI's Terms of Sale](#) or other applicable terms available either on [ti.com](https://www.ti.com) or provided in conjunction with such TI products. TI's provision of these resources does not expand or otherwise alter TI's applicable warranties or warranty disclaimers for TI products.

TI objects to and rejects any additional or different terms you may have proposed.

Mailing Address: Texas Instruments, Post Office Box 655303, Dallas, Texas 75265  
Copyright © 2024, Texas Instruments Incorporated

## Looking for pricing, stock, or lifecycle information?

Click below to explore more details on WIN SOURCE:

 [View SNJ54S112J on WIN SOURCE](#)

 [Texas Instruments](#) Information

## Optimize Your Supply Chain with WIN SOURCE Solutions

-  Global Sourcing Solution
-  Obsolete Management
-  Cost Control Management
-  Shortage Management
-  Alternative Solution
-  Excess Inventory Management