



**THE DATASHEET OF**  
**78M6631-IM/F**



# 78M6631 3-Phase Power- Measurement IC

## DATA SHEET

DS\_6631\_056

### DESCRIPTION

The Teridian™ 78M6631 is a highly integrated 3-phase power measurement and monitoring system-on-chip (SoC), with a 10 MHz 8051-compatible MPU core and Single Converter Technology® containing a 22-bit delta-sigma converter and 32-bit compute engine (CE). The 78M6631 has been designed specifically for a wide variety of applications requiring 3-phase power and quality measurements. It supports both Delta and Wye configurations.

At the measurement interface, the device provides six analog inputs including three differential current and three voltage for interfacing to current and voltage sensors. The device provides better than 0.5% accuracy over a wide 2000:1 dynamic range.

The integrated MPU core and 128 KB of flash memory provide a flexible means of configuration, post-processing, data formatting, interfacing to host processor via a UART or SPI interface, or using DIO pins for LEDs or relay control. Complete firmware is available from Maxim and can be loaded into the IC during manufacturing test.

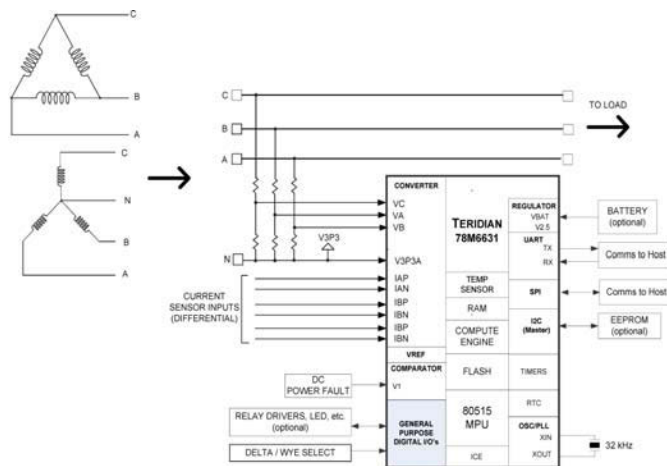

### FEATURES

- < 0.5% Watt Accuracy Over 2000:1 Current Range and Over Temperature
- Exceeds IEC 62053/ANSI C12.20 Standards
- Voltage Reference < 40 ppm/°C
- Six Analog Inputs Supporting 3-Phase Voltage and Current Measurement Inputs
- Pin- or Biselectable Delta or Wye Configuration
- 22-Bit Delta-Sigma ADC with Independent 32-Bit Compute Engine (CE)
- 8-Bit MPU (80515), One Clock Cycle per Instruction with 4 KB MPU XRAM
- 128 KB Flash with Security
- 32 kHz Time Base with Hardware Watchdog Timer
- UART, I<sup>2</sup>C, and High-Speed Slave SPI Host Interface Options
- 17 General-Purpose 5 V Tolerant I/O Pins
- Packaged in a RoHS-Compliant (6/6) Lead(Pb)-Free 56-Pin TQFN
- Application Firmware Includes (per Phase):
  - True RMS Current and Voltage Calculations
  - Active, Reactive, Apparent, Fundamental, and Harmonic Power Calculations
  - Fundamental and Harmonic Current and Voltage Calculations
  - Line Frequency and Power Factor Calculations
  - Phase Compensation ( $\pm 18^\circ$  at 60 Hz)
  - Built-In Calibration Routines
  - Programmable Alarm Thresholds
  - Command Line (UART) Communications
  - High-Speed SPI Communications

*Teridian is a trademark and Single Converter Technology is a registered trademark of Maxim Integrated Products, Inc.*

**For pricing, delivery, and ordering information, please contact Maxim Direct at 1-888-629-4642, or visit Maxim's website at [www.maximintegrated.com](http://www.maximintegrated.com).**

## Table of Contents

<b>1</b>	<b>Hardware Functional Description</b>	<b>5</b>
1.1	Hardware Overview	5
1.2	Device Reset	7
1.3	Power Management	7
1.3.1	Voltage Regulator	7
1.3.2	Power Fault Management	7
1.4	Analog Front-End (AFE)	8
1.4.1	Analog Current and Voltage Inputs	8
1.5	Digital Computation Engine (CE)	9
1.6	80515 MPU Core	10
1.6.1	SFRs	10
1.7	RAM	10
1.8	IORAM	10
1.9	Flash	10
1.9.1	Program Security	10
1.10	Oscillator	11
1.11	PLL and Internal Clock Generation	11
1.12	Real-Time Clock (RTC)	11
1.13	Hardware Watchdog Timer	11
1.14	Temperature Sensor	12
1.15	General Purpose Digital I/O	12
1.16	D/Y Selection Pin	12
1.17	EEPROM Interface	12
1.18	SPI Slave Port	12
1.19	Test Port	13
1.20	UART	13
1.21	In Circuit Emulator (ICE) Port	14
<b>2</b>	<b>Electrical Specifications</b>	<b>15</b>
2.1	Absolute Maximum Ratings	15
2.2	Recommended External Components	16
2.3	Recommended Operating Conditions	16
2.4	Performance Specifications	17
2.4.1	Input Logic Levels	17
2.4.2	Output Logic Levels	17
2.4.3	Power-Fault Comparator	17
2.4.4	Power Supply Monitor	18
2.4.5	Supply Current	18
2.4.6	Crystal Oscillator	18
2.4.7	Temperature Sensor	19
2.4.8	VREF	19
2.4.9	ADC Converter, V3P3A Referenced	20
2.5	Timing Specifications	21
2.5.1	Flash Memory	21
2.5.2	EEPROM Interface	21
2.5.3	RESET	21
2.5.4	SPI Slave Port	22
<b>3</b>	<b>Packaging</b>	<b>23</b>
3.1	56-Pin QFN Package	23
3.2	Pinout	23
3.2.1	56-Pin QFN Package Outline	24
3.2.2	Recommended PCB Land Pattern for the QFN-56 Package	25
<b>4</b>	<b>Pin Descriptions</b>	<b>26</b>

---

4.1	Power and Ground Pins.....	26
4.2	Analog Pins.....	26
4.3	Digital Pins.....	27
<b>5</b>	<b>I/O Equivalent Circuits.....</b>	<b>28</b>
<b>6</b>	<b>Ordering Information.....</b>	<b>29</b>
<b>7</b>	<b>Contact Information.....</b>	<b>29</b>
	<b>Revision History.....</b>	<b>30</b>

## Figures

Figure 1: 78M6631 IC Functional Block Diagram .....	6
Figure 2: AFE Block Diagram .....	8
Figure 3: Functions Defined by V1 .....	11
Figure 4: SPI Slave Port: Typical Read and Write Operations .....	13
Figure 5: SPI Slave Port Timing .....	22
Figure 6: Pinout for QFN-56 Package .....	23
Figure 7: PCB Land Pattern for QFN-56 Package .....	25
Figure 8: I/O Equivalent Circuits .....	28

## Tables

Table 1: SPI Command Description .....	13
Table 2: Absolute Maximum Ratings .....	15
Table 3: Recommended External Components .....	16
Table 4: Recommended Operating Conditions .....	16
Table 5: Input Logic Levels .....	17
Table 6: Output Logic Levels .....	17
Table 7: Power-Fault Comparator Performance Specifications .....	17
Table 8: Power Supply Monitor Performance Specifications ( $BME=1$ ) .....	18
Table 9: Supply Current Performance Specifications .....	18
Table 10: Crystal Oscillator Performance Specifications .....	18
Table 11: Temperature Sensor Performance Specifications .....	19
Table 12: VREF Performance Specifications .....	19
Table 13: ADC Converter Performance Specifications .....	20
Table 14: Flash Memory Timing Specifications .....	21
Table 15: EEPROM Interface Timing .....	21
Table 16: RESET Timing .....	21
Table 17: SPI Slave Port Timing .....	22
Table 19: Power and Ground Pins .....	26
Table 20: Analog Pins .....	26
Table 21: Digital Pins .....	27
Table 22: Ordering Information .....	29

# 1 Hardware Functional Description

## 1.1 Hardware Overview

The Teridian 78M6631 single-chip power measurement and monitoring device integrates all the primary AC measurement and control blocks required to implement the 3-phase power measurement and monitoring system.

The 78M6631 includes:

- Six input analog front-end (AFE) (3 Differential Current/3 Voltage)
- Independent digital computation engine (CE)
- 8051-compatible microprocessor (MPU) which executes one instruction per clock cycle (80515)
- Precision voltage reference
- Temperature sensor
- RAM and flash memory
- A variety of I/O pins
- Communication Interfaces: UART, SPI, and I<sup>2</sup>C (Master)

Various current sensor technologies are supported including Current Transformers (CT), Resistive Shunts, and Rogowski coils.

The 32-bit compute engine (CE) of the 78M6631 sequentially process the samples from the analog inputs on pins IA, IB, IC, VA, VB, and VC and performs calculations to measure active power (Watts), reactive power (VARs), apparent power (VAs), power factor, fundamental power, and harmonic power for three independent phases. RMS, fundamental, and harmonic currents and voltages are also computed for each phase. Totals are available for most results.

[Figure 1](#) provides a block diagram of the 78M6631 IC. A detailed description of the various functional blocks follows.

Refer to the applicable Firmware Description Document for additional supported functionality.

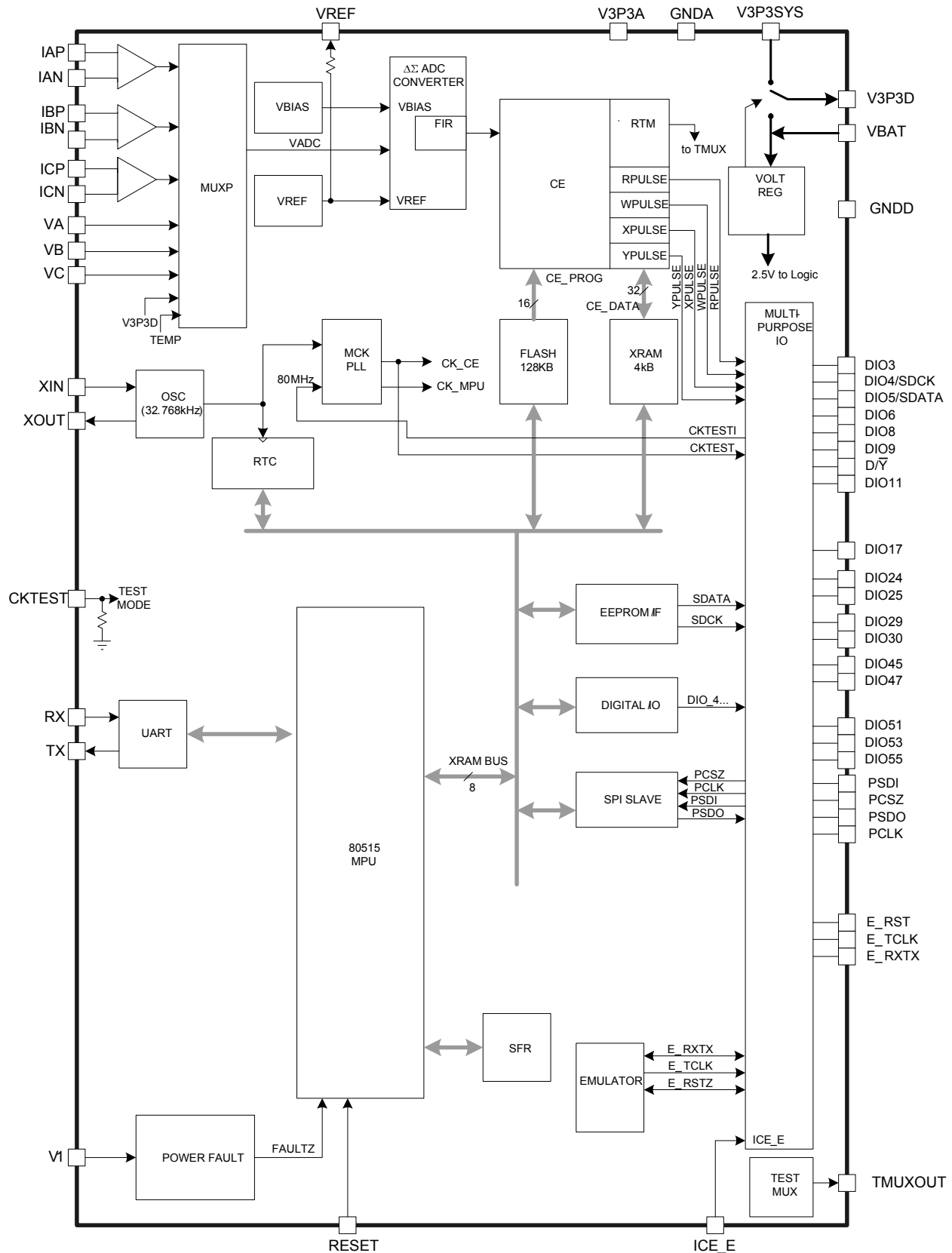

Figure 1: 78M6631 IC Functional Block Diagram

## 1.2 Device Reset

When the RESET pin is pulled high, all digital activity stops. Only the oscillator and RTC module continue to run. Additionally, all IORAM bits are set to their default states. As long as V1 (the input voltage at the power fault block) is greater than VBIAS, the internal 2.5 V regulator continues to provide power to the digital section.

Once initiated, the reset mode persists until the reset timer times out. This occurs in 4096 cycles of the crystal clock after RESET goes low, at which time the MPU begins executing its preboot and boot sequences from address 0x0000.

## 1.3 Power Management

### 1.3.1 Voltage Regulator

The 78M6631 provides an on-chip voltage regulator to create a 2.5 V supply for the digital logic. This regulator can be run off of the V3P3SYS or VBAT inputs depending upon power availability.

### 1.3.2 Power Fault Management

The 78M6631 provides for both hardware and software controlled power fault management. The V1 pin is connected to a comparator to monitor system power fault conditions. When the input to the comparator falls ( $V1 < VBIAS$ ) the device can enter a BROWNOUT mode, if supported in firmware and there is sufficient voltage on VBAT, that reduces the MPU rate to 32 kHz and disables all the measurement front-end circuits. If the overhead on VBAT is insufficient to maintain a BROWNOUT mode, then the device can also attempt to enter a SLEEP mode where only RTC functions are active.

If there is not sufficient voltage on VBAT (or it is not supported), then the part enters RESET mode when the comparator fails.

## 1.4 Analog Front-End (AFE)

The AFE functions as a data acquisition system, controlled by the MPU. The main blocks in the AFE consist of an input multiplexer, a delta-sigma A/D converter, a FIR decimation filter and a voltage reference. The metrology input signals (IAP, IAN, IBP, IBN, ICP, ICN, VA, VB, VC, and TEMP) are multiplexed before being sampled by the ADC. The ADC output is decimated by the FIR filter and the results are stored in RAM where they can be accessed by the CE and the MPU.

The functionality of the AFE is established for various system requirements with different CE code. AFE programmability includes, but is not limited to:

- Input multiplexer settings
- Voltage supply and temperature monitor inputs
- ADC sampling rate
- FIR length/resolution

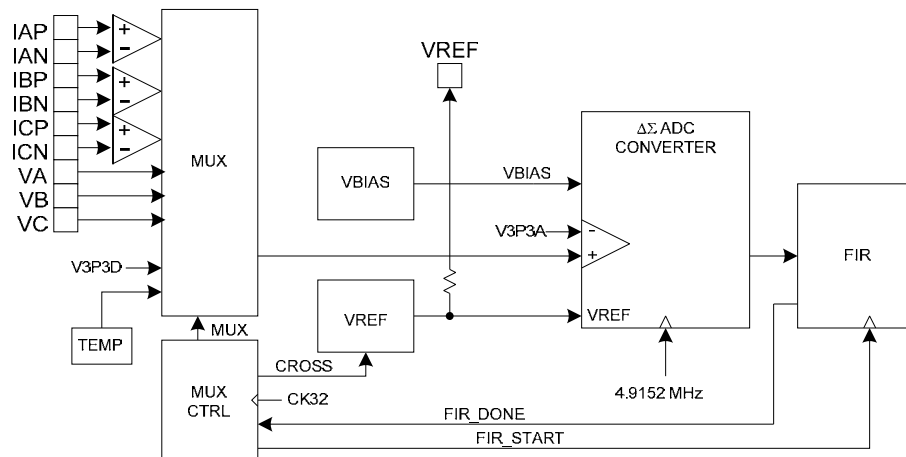

Figure 2: AFE Block Diagram

### 1.4.1 Analog Current and Voltage Inputs

With all CE code implementations for the 78M6631, pins IAP, IAN, IBP, IBN, ICP, ICN, VA, VB, and VC are analog inputs to the AFE for measuring current and voltage. Various current sensor technologies can be supported including Current Transformers, Resistive Shunts, and Rogowski coils.

## 1.5 Digital Computation Engine (CE)

The CE, a dedicated 32-bit digital signal processor, performs the back-end computations. CE calculations include:

- Gain and offset compensation
- Delay compensation on all channels
- 90° phase shift for VAR calculations
- Frequency measurement
- Accumulation for voltage and current RMS and power computation
- Active, reactive, apparent, fundamental, and harmonic power calculation
- Fundamental and harmonic current and voltage calculations
- Monitoring of the input signal frequency (for frequency and phase information)
- Monitoring of the input signal amplitude (for sag detection)
- Temperature acquisition



Due to the custom nature and complexity of the CE, the CE code is part of the installed firmware and is not modified by the user. Contact Maxim support for more information regarding CE code.

## 1.6 80515 MPU Core

The 78M6631 includes an 80515 MPU (8-bit, 8051-compatible) that processes most instructions in one clock cycle. The 80515 architecture eliminates redundant bus states and implements parallel execution of fetch and execution phases. Normally, a machine cycle is aligned with a memory fetch, therefore, most of the 1-byte instructions are performed in a single machine cycle (MPU clock cycle). This leads to an 8x average performance improvement (in terms of MIPS) over the Intel 8051 device running at the same clock frequency.

### 1.6.1 SFRs

Several custom Special Function Registers (SFR) are implemented in the 78M6631's 80515 MPU. Refer to the *78M6631 Programmer's Reference Manual* for more information regarding the mapping of functionality to specific SFR and IORAM addresses.

## 1.7 RAM

The CE and MPU share a single, general purpose 4KB RAM (also referred to as XRAM) for data. The XRAM is natively accessible as 32-bit words from the CE and on 8-bit boundaries from the CPU. The XRAM is accessed by the CPU through addresses 0x0000 to 0x0FFF.

## 1.8 IORAM

The MPU accesses most of its external input and output functionality as well as programmable functionality through memory mapped IO (IORAM). The IORAM is accessed by the CPU as data addresses 0x2000 to 0x20FF.

## 1.9 Flash

The 78M6631 includes 128 KB of on-chip flash memory. For read/write access from the CPU, the flash is broken into four 32 KB banks that are managed by SFR settings. For erasing of the flash memory from the CPU, the flash is segmented into individual 1024-byte pages and also controlled by SFR settings.

### 1.9.1 Program Security

The 78M6631 has functionality to guarantee the security of the user's MPU and CE program code. When enabled, the security feature limits the ICE to global flash erase operations only. All other ICE operations are blocked. Security is enabled by MPU code that is executed in a pre-boot interval before the primary boot sequence begins. Once security is enabled, the only way to disable it is to perform a global erase of the flash, followed by a chip reset.

## 1.10 Oscillator

The 78M6631 oscillator drives a standard 32.768 kHz quartz crystal. These crystals are accurate and do not require a high-current oscillator circuit. The 78M6631 oscillator has been designed specifically to handle these crystals and is compatible with their high impedance and limited power handling capability.

The oscillator is powered directly and only from V3P3D, which therefore must be connected to a DC voltage source not to exceed 4 V.



Since the oscillator is self-biasing, an external resistor must not be connected across the crystal.

## 1.11 PLL and Internal Clock Generation

Timing for the device is derived from the 32.768 kHz crystal oscillator output. The PLL and on-chip timing functions provide several clocks which include:

- The MPU clock (CKMPU)
- The emulator clock (2 x CKMPU)
- The clock for the CE (CKCE)
- The delta-sigma ADC and FIR clock(CKADC, CKFIR)

These internal clocks can be adjusted for various programmable rates which affect device functionality. Refer to the *78M6631 Programmer's Reference Manual* for more information regarding the programmability of the 78M6631 PLL and internal clock generation modules.

## 1.12 Real-Time Clock (RTC)

The RTC circuit is driven directly by the crystal oscillator. The RTC consists of a counter chain and output registers. The counter chain consists of registers for seconds, minutes, hours, day of week, day of month, month, and year (including leap years). Refer to the *78M6631 Programmer's Reference Manual* for more information regarding the use of the 78M6631 RTC.

## 1.13 Hardware Watchdog Timer

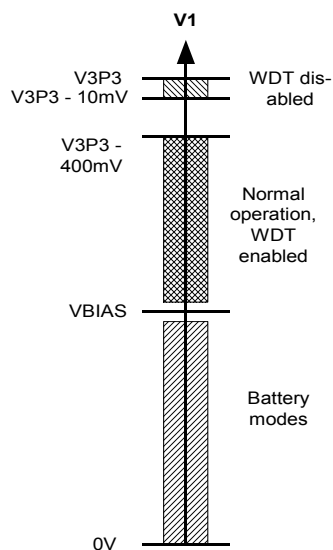

In addition to the basic watchdog timer included in the 80515 MPU, an independent, robust, fixed-duration, watchdog timer (WDT) is included in the device. It uses the crystal oscillator as its time base and must be refreshed by the MPU firmware at least every 1.5 seconds. When not refreshed on time the WDT overflows, and the part is reset as if the RESET pin were pulled high, except that the IORAM bits are maintained. 4096 oscillator cycles (or 125 ms) after the WDT overflow, the MPU is launched from program address 0x0000. Asserting ICE\_E deactivates the WDT.

The WDT can also be disabled by connecting the V1 pin to V3P3D. This also deactivates V1 power fault detection. Since there is no method in firmware to disable the crystal oscillator or the WDT, it is guaranteed that whatever state the part might find itself in, upon watchdog overflow, the part is reset to a known state.

Figure 3: Functions Defined by V1

## 1.14 Temperature Sensor

The device includes an on-chip temperature sensor for determining the temperature of the bandgap reference. The primary use of the temperature data is to determine the magnitude of compensation required to offset the thermal drift in the system.

## 1.15 General-Purpose Digital I/O

The 78M6631 includes 17 general-purpose digital I/O pins. As inputs, these pins are 5V compatible (no current-limiting resistors are needed). On reset or power-up, all DIO pins are inputs. Their input/output directions are subsequently set by the MPU. The digital I/O pins can be categorized as follows:

- DIO3 (1 pin) DIO pin
- DIO4, DIO5 (2 pins) DIO/EEPROM
- DIO6 (1 pin) DIO pin (multifunction)
- DIO8, DIO9, DIO11 (3 pins) DIO pins
- DIO17 (1 pin) DIO pin
- DIO24, DIO25 (2 pins) DIO pins
- DIO29, DIO30 (2 pins) DIO pins
- DIO45, DIO47 (2 pins) DIO pins
- DIO51 (1 pin) DIO pin
- DIO53, DIO55 (2 pins) DIO pins

## 1.16 D/Y Selection Pin

The D/Y pin selects either the Delta or the Wye configuration. At power-on, the Delta/Wye selection register assumes the state of the D/Y pin. The register value can be modified by the software overriding the state of the D/Y pin.

## 1.17 EEPROM Interface

The 78M6631 provides hardware support for an optional 2-pin or a 3-wire (MICROWIRE<sup>®</sup>) EEPROM interface.

### 2-Pin EEPROM Interface

The dedicated 2-pin serial interface communicates with external EEPROM devices. The interface is multiplexed onto the DIO4 (SDCK) and DIO5 (SDATA) pins.

### 3-Wire (MICROWIRE) EEPROM Interface

A 500 kHz three-wire interface, using SDATA, SDCK and a DIO pin for CS, is also available.

## 1.18 SPI Slave Port

The slave SPI port communicates directly with the MPU data bus and is able to directly read and write XRAM and IORAM locations. It is also able to send commands to the MPU. The interface to the slave port consists of the PCSZ, PCLK, PSDI, and PSDO pins.

A typical SPI transaction is as follows. While PCSZ is high, the port is held in an initialized/reset state. During this state, PSDO is held in high-Z state and all transitions on PCLK and PSDI are ignored. When PCSZ falls, the port begins the transaction on the first rising edge of PCLK. A transaction consists of an 8-bit command, a 16-bit address, and then one or more bytes of data. The transaction ends when PCSZ is raised. Some transactions can consist of a command only. The last SPI command and address (if part of the command) are available in the IORAM.

The SPI port supports data transfers at up to 1 Mbps. The SPI commands are described in Table 1 and Figure 4 illustrates the SPI Interface read and write timing.

*MICROWIRE is a registered trademark of National Semiconductor.*

**Table 1: SPI Command Description**

Command	Description
11xx xxxx ADDR D0 ... DN	Output data on PSDO is read from RAM starting with byte at ADDR. ADDR auto increments until PCSZ is raised. MPU SPI interrupt is generated.
1100 0000 ADDR D0 ... DN	Output data on PSDO is read from RAM starting with byte at ADDR. ADDR auto increments until PCSZ is raised. No MPU SPI interrupt is generated.
10xx xxxx ADDR D0 ... DN	Input data on PSDI is written to RAM starting with byte at ADDR. ADDR auto increments until PCSZ is raised. MPU SPI interrupt is generated.
1000 0000 ADDR D0 ... DN	Input data on PSDI is written to RAM starting with byte at ADDR. ADDR auto increments until PCSZ is raised. No MPU SPI interrupt is generated.
CMD ADDR D0 ... DN	CMD and ADDR are available to the CPU in IORAM. D0... DN are ignored. MPU SPI interrupt is generated.

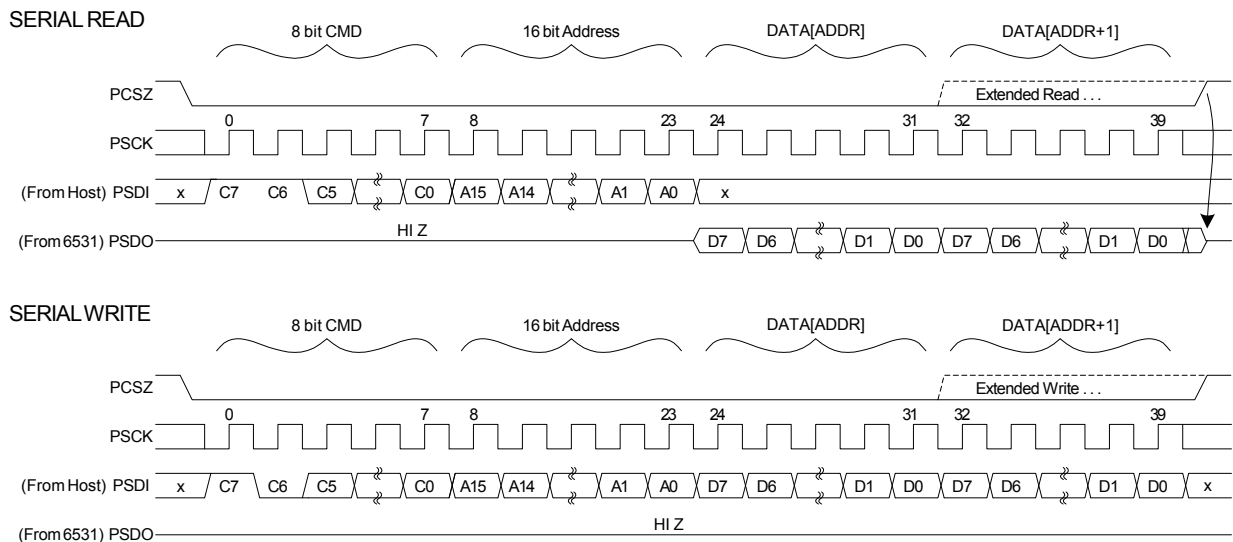

**Figure 4: SPI Slave Port: Typical Read and Write Operations**

Since the addresses are in 16-bit format, any type of XRAM data can be accessed: CE, MPU, or IORAM but not SFRs or the 80515-internal register bank.

### 1.19 Test Port

One out of 16 digital or eight analog signals can be selected to be output on the TMUXOUT pin. Refer to the *78M6631 Programmer's Reference Manual* for more information regarding the use of TMUXOUT.

### 1.20 UART

The 78M6631 includes one UART (UART0) that can be programmed to communicate with a variety of external devices. The UART is a dedicated 2-wire serial interfaces (no hardware flow control/handshaking), which can communicate at rates up to 38,400 bps. All UART transfers are programmable for parity enable, parity, 2 stop bits/1 stop bit and XON/XOFF options for variable communication baud rates from 300 to 38,400 bps. Refer to the *78M6631 Programmer's Reference Manual* for more information regarding the use of the UART resources.

## 1.21 In-Circuit Emulator (ICE) Port

The 78M6631 implements an In-Circuit Emulator (ICE) port for debug and programming of the device. To enable the use of the port the ICE\_E pin must be pulled high. In this mode the E\_RST, E\_TCLK, and E\_RXTX pins are enabled. Contact Maxim support for more information regarding the use of the ICE interface for device programming and debug.

## 2 Electrical Specifications

### 2.1 Absolute Maximum Ratings

Table 2 shows the absolute maximum ranges for the device. Stresses beyond Absolute Maximum Ratings may cause permanent damage to the device. These are stress ratings only and functional operation at these or any other conditions beyond those indicated under recommended operating conditions (Section 2.3) is not implied. Exposure to absolute-maximum-rated conditions for extended periods may affect device reliability. All voltages are with respect to GNDA.

**Table 2: Absolute Maximum Ratings**

<b>Voltage and Current</b>	
<b>Supplies and Ground Pins</b>	
V3P3D, V3P3A	-0.5 V to 4.0 V
GNDD	-0.5 V to +0.5 V
<b>Analog Output Pins</b>	
VREF	-10 mA to +10 mA, -0.5 V to (V3P3A + 0.5 V)
<b>Analog Input Pins</b>	
IAP, IAN, IBP, IBN, ICP, ICN, VA, VB, VC	-10 mA to +10 mA -0.5 V to (V3P3A + 0.5 V)
XIN, XOUT	-10 mA to +10 mA -0.5 V to 3.0 V
<b>All Other Pins</b>	
Configured as Digital Inputs	-10 mA to +10 mA, -0.5 to +6 V
Configured as Digital Outputs	-15 mA to +15 mA, -0.5 V to (V3P3D + 0.5 V)
All Other Pins	-0.5 V to (V3P3D + 0.5 V)
<b>Temperature and ESD Stress</b>	
Operating Junction Temperature (peak, 100 ms)	+140°C
Operating Junction Temperature (continuous)	+125°C
Storage Temperature	-45°C to +165°C
Lead Temperature (soldering, 10 s)	+250°C
Soldering Temperature (reflow)	+260°C
ESD Stress on All Pins	±4 kV

## 2.2 Recommended External Components

**Table 3: Recommended External Components**

Name	From	To	Function	Value	Unit
C1	V3P3A	AGND	Bypass capacitor for 3.3 V supply	$\geq 0.1 \pm 20\%$	$\mu\text{F}$
C3	V3P3D	DGND	Bypass capacitor for V3P3D	$\geq 1.0 \pm 30\%$	$\mu\text{F}$
XTAL	XIN	XOUT	32.768 kHz crystal, electrically similar to ECS .327-12.5-17X or Vishay XT26T, load capacitance 12.5 pF	32.768	kHz
CXS	XIN	AGND	Load capacitor for crystal (depends on crystal specs and board parasitics)	$33 \pm 10\%$	pF
CXL	XOUT	AGND	Load capacitor for crystal (depends on crystal specs and board parasitics)	$15 \pm 10\%$	pF

Notes:

1. AGND and DGND should be connected together.
2. V3P3Ds and V3P3A should be connected together.

## 2.3 Recommended Operating Conditions

**Table 4: Recommended Operating Conditions**

Parameter	Condition	Min	Typ	Max	Unit
V3P3D, V3P3A: 3.3 V Supply Voltage (V3P3A and V3P3D must be at the same voltage)	Normal operation	3.0	3.3	3.6	V
Operating Temperature Range		-40		+85	$^{\circ}\text{C}$

## 2.4 Performance Specifications

### 2.4.1 Input Logic Levels

Table 5: Input Logic Levels

Parameter	Condition	Min	Typ	Max	Unit
Digital high-level input voltage <sup>1</sup> , $V_{IH}$		2			V
Digital low-level input voltage <sup>1</sup> , $V_{IL}$				0.8	V
Input pullup current, $I_{IL}$ E_RXTX, E_RST, CKTEST Other digital inputs	$V_{IN} = 0\text{ V}$ , ICE_E = 1	10 10 -1	0	100 100 +1	$\mu\text{A}$ $\mu\text{A}$ $\mu\text{A}$
Input pulldown current, $I_{IH}$ ICE_E RESET Other digital inputs	$V_{IN} = V3P3D$	10 10 -1	0	100 100 +1	$\mu\text{A}$ $\mu\text{A}$ $\mu\text{A}$

<sup>1</sup> To reduce power consumption, digital inputs should be below 0.3 V or above 2.5 V to minimize supply current.

### 2.4.2 Output Logic Levels

Table 6: Output Logic Levels

Parameter	Condition	Min	Typ	Max	Unit
Digital high-level output voltage $V_{OH}$	$I_{LOAD} = 1\text{ mA}$	V3P3D - 0.4			V
	$I_{LOAD} = 15\text{ mA}$	V3P3D - 0.6			V
Digital low-level output voltage $V_{OL}$	$I_{LOAD} = 1\text{ mA}$	0		0.4	V
	$I_{LOAD} = 15\text{ mA}$			0.8	V

### 2.4.3 Power-Fault Comparator

Table 7: Power-Fault Comparator Performance Specifications

Parameter	Condition	Min	Typ	Max	Unit
Offset Voltage: V1 - VBIAS		-20		+15	mV
Hysteresis Current: V1	$V_{IN} = VBIAS - 100\text{ mV}$	0.8		1.2	$\mu\text{A}$
Response Time: V1	+100 mV overdrive Voltage at V1 rising		8	100	$\mu\text{s}$
	Voltage at V1 falling	10	37	100	$\mu\text{s}$
WDT Disable Threshold: V1 - V3P3A		-400		-10	mV

## 2.4.4 Power Supply Monitor

**Table 8: Power Supply Monitor Performance Specifications (BME= 1)**

Parameter		Condition	Min	Typ	Max	Unit
Load Resistor		–	27	45	63	kΩ
LSB Value	[M40MHZ, M26MHZ] = [00], [10], or [11]	FIR_LEN=0(L=138) FIR_LEN=1(L=288)	(-10%)	-48.7 -5.35	(+10%)	μV μV
	[M40MHZ, M26MHZ] = [01]	FIR_LEN=0(L=186) FIR_LEN=1(L=384)	(-10%)	-19.8 -2.26	(+10%)	μV μV
Offset Error			-200	0	+100	mV

## 2.4.5 Supply Current

**Table 9: Supply Current Performance Specifications**

Parameter	Condition	Min	Typ	Max	Unit
V3P3D current (CE off)	Normal Operation, V3P3A = V3P3SYS = 3.3 V CKMPSU = 614 kHz No flash memory write RTM_E=0, ECK_DIS=1, ADC_E=1, ICE_E=0		4.2	6.35	mA
V3P3D current (CE on)			8.4	9.6	mA
V3P3A current			3.3	3.8	mA
V3P3D current, Write Flash	Normal operation as above, except write flash at maximum rate, CE_E = 0, ADC_E = 0		9.1	12	mA

## 2.4.6 Crystal Oscillator

**Table 10: Crystal Oscillator Performance Specifications**

Parameter	Condition	Min	Typ	Max	Unit
Maximum Output Power to Crystal <sup>4</sup>	Crystal connected			1	μW
XIN to XOUT Capacitance <sup>1</sup>				3	pF
Capacitance to DGND <sup>1</sup> XIN XOUT	RTCA_ADJ = 0			5 5	pF pF

## 2.4.7 Temperature Sensor

Table 11 shows the performance for the temperature sensor. The LSB values do not include the 8-bit left shift at CE input.

**Table 11: Temperature Sensor Performance Specifications**

Parameter	Condition	Min	Typ	Max	Unit
Nominal relationship: $N(T) = S_n \cdot (T - T_n) + N_n$ , $T_n = 22^\circ\text{C}$					
Nominal Sensitivity ( $S_n$ )	[M26MHZ, M40MHZ] = [00], [01], or [11]	$FIR\_LEN=0$ (L=138) $FIR\_LEN=1$ (L=288)		-104 -947	LSB/ $^\circ\text{C}$
$S_n = -0.00107 \cdot \left(\frac{L}{3}\right)^3$	[M26MHZ, M40MHZ] = [10]	$FIR\_LEN=0$ (L=186)		-255	
Nominal Offset ( $N_n$ ) <sup>4</sup>	[M26MHZ, M40MHZ] = [00], [01], or [11]	$FIR\_LEN=0$ (L=138) $FIR\_LEN=1$ (L=288)		49641 451200	LSB
$N_n = 0.510 \cdot \left(\frac{L}{3}\right)^3$	[M26MHZ, M40MHZ] = [10]	$FIR\_LEN=0$ (L=186)		121500	
Temperature Error <sup>2</sup>		$T_n = 22^\circ\text{C}$ , $T = -40^\circ\text{C}$ to $+85^\circ\text{C}$		-10 <sup>1</sup>	+10 <sup>1</sup> $^\circ\text{C}$
$ERR = T - \left\{ \frac{(N(T) - N_n)}{S_n} + T_n \right\}$					

<sup>1</sup> Guaranteed by design; not production tested.

<sup>2</sup>  $N_n$  is measured at  $T_n$  during measurement calibration and is stored in MPU or CE for use in temperature calculations.

## 2.4.8 VREF

Table 12 shows the performance specifications for VREF. Unless otherwise specified,  $VREF\_DIS = 0$ .

**Table 12: VREF Performance Specifications**

Parameter	Condition	Min	Typ	Max	Unit
VREF output voltage, VREF(22)	$T_A = +22^\circ\text{C}$	1.193	1.195	1.197	V
VREF chop step				40	mV
VREF power supply sensitivity $\Delta VREF / \Delta V3P3A$	V3P3A = 3.0 to 3.6 V	-1.5		+1.5	mV/V
VREF input impedance	$VREF\_DIS = 1$ , VREF = 1.3 to 1.7 V	100			k $\Omega$
VREF output impedance	CAL = 1, ILOAD = 10 $\mu\text{A}$ , -10 $\mu\text{A}$			2.5	k $\Omega$
VNOM definition <sup>2</sup>	$VNOM(T) = VREF(22) + (T - 22)TC1 + (T - 22)^2 TC2$				V
VNOM temperature coefficients: TC1 TC2		3.18 · (52.46 - TRIMT) -0.444			$\mu\text{V}/^\circ\text{C}$ $\mu\text{V}/^\circ\text{C}^2$
VREF(T) deviation from VNOM(T) $\frac{VREF(T) - VNOM(T)}{VNOM(T)} \cdot \frac{10^6}{\max( T - 22 , 40)}$		-40 <sup>1</sup>		+40 <sup>1</sup>	ppm/ $^\circ\text{C}$
VREF aging			±25		ppm/year

<sup>1</sup> Guaranteed by design; not production tested.

<sup>2</sup> This relationship describes the nominal behavior of VREF at different temperatures.

## 2.4.9 ADC Converter, V3P3A Referenced

Table 13 shows the performance specifications for the ADC converter, V3P3A referenced. For this data,  $FIR\_LEN = 0$ ,  $VREF\_DIS = 0$  and LSB values do not include the 9-bit left shift at the CE input.

**Table 13: ADC Converter Performance Specifications**

Parameter	Condition	Min	Typ	Max	Unit
Recommended Input Range ( $V_{IN} - V3P3A$ )		-250		+250	mV peak
Voltage to Current Crosstalk $\frac{10^6 * V_{crosstalk}}{V_{in}} \cos(\angle V_{in} - \angle V_{crosstalk})$	$V_{IN} = 200$ mV peak, 65 Hz, on VA. Vcrosstalk = largest measurement on IA or IB	-10 <sup>1</sup>		+10 <sup>1</sup>	$\mu$ V/V
THD (First 10 harmonics) <sup>1</sup> : 250 mV-pk 20 mV-pk	$V_{IN} = 65$ Hz, 64 kpts FFT, Blackman- Harris window CKCE = 5 MHz			-75 <sup>1</sup> -90 <sup>1</sup>	dB dB
Input Impedance	$V_{IN} = 65$ Hz	40		90	k $\Omega$
Temperature coefficient of Input Impedance	$V_{IN} = 65$ Hz		1.7		$\Omega/^\circ$ C
LSB size $V_{LSB} = V_{REF} \cdot \frac{1.25}{4.75} \cdot \left(\frac{3}{L}\right)^3$ L = FIR length	[M40MHZ, M26MHZ] = [00], [10], or [11]				nV/ LSB
	[M40MHZ, M26MHZ] = [01]				nV/ LSB
Digital Full Scale $\left(\frac{L}{3}\right)^3$ L = FIR length	[M40MHZ, M26MHZ] = [00], [10], or [11]				LSB
	[M40MHZ, M26MHZ] = [01]				LSB
ADC Gain Error versus %Power Supply Variation $\frac{10^6 \Delta N_{out_{PK}} 357nV / V_{IN}}{100 \Delta V_{3P3A} / 3.3}$	$V_{IN} = 200$ mV pk, 65 Hz, V3P3A=3.0 V, 3.6 V			50	ppm/%
Input Offset ( $V_{IN} - V3P3A$ )		-10		+10	mV

<sup>1</sup> Guaranteed by design; not production tested.

## 2.5 Timing Specifications

### 2.5.1 Flash Memory

Table 14: Flash Memory Timing Specifications

Parameter	Condition	Min	Typ	Max	Unit
Flash write cycles	-40°C to +85°C	20,000			Cycles
Flash data retention	+25°C	100			Years
Flash data retention	+85°C	10			Years
Flash byte write operations between page or mass erase operations				2	Cycles
Write Time per Byte				42	μs
Page Erase (1024 bytes)				20	ms
Mass Erase				200	ms

### 2.5.2 EEPROM Interface

Table 15: EEPROM Interface Timing

Parameter	Condition	Min	Typ	Max	Unit
Write Clock frequency (I <sup>2</sup> C)	CKMPU = 4.9152 MHz, using interrupts		78		kHz
	CKMPU = 4.9152 MHz, bit-banging DIO4/5		150		kHz
Write Clock frequency (3-wire)	CKMPU = 4.9152 MHz		500		kHz

### 2.5.3 RESET

Table 16: RESET Timing

Parameter	Condition	Min	Typ	Max	Unit
Reset pulse width		5			μs
Reset pulse fall time				1 <sup>1</sup>	μs

<sup>1</sup> Guaranteed by design; not production tested.

2.5.4 SPI Slave Port

Table 17: SPI Slave Port Timing

Parameter	Condition	Min	Typ	Max	Unit
$t_{SPIcyc}$ PCLK cycle time		1			$\mu$ s
$t_{SPILead}$ Enable lead time		15			ns
$t_{SPILag}$ Enable lag time		0			ns
$t_{SPIW}$ PCLK pulse width	High	40			ns
	Low	40			
$t_{SPISCK}$ PCSZ to first PCLK fall	Ignore if PCLK is low when PCSZ falls	2			ns
$t_{SPIDIS}$ Disable time		0			ns
$t_{SPIEV}$ PCLK to Data Out				15	ns
$t_{SPISU}$ Data input setup time		10			ns
$t_{SPIH}$ Data input hold time		5			ns

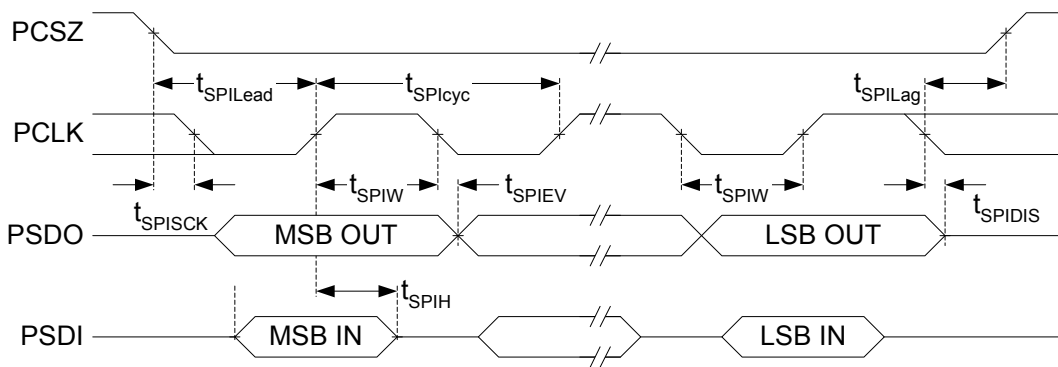

Figure 5: SPI Slave Port Timing

### 3 Packaging

#### 3.1 56-Pin QFN Package

#### 3.2 Pinout

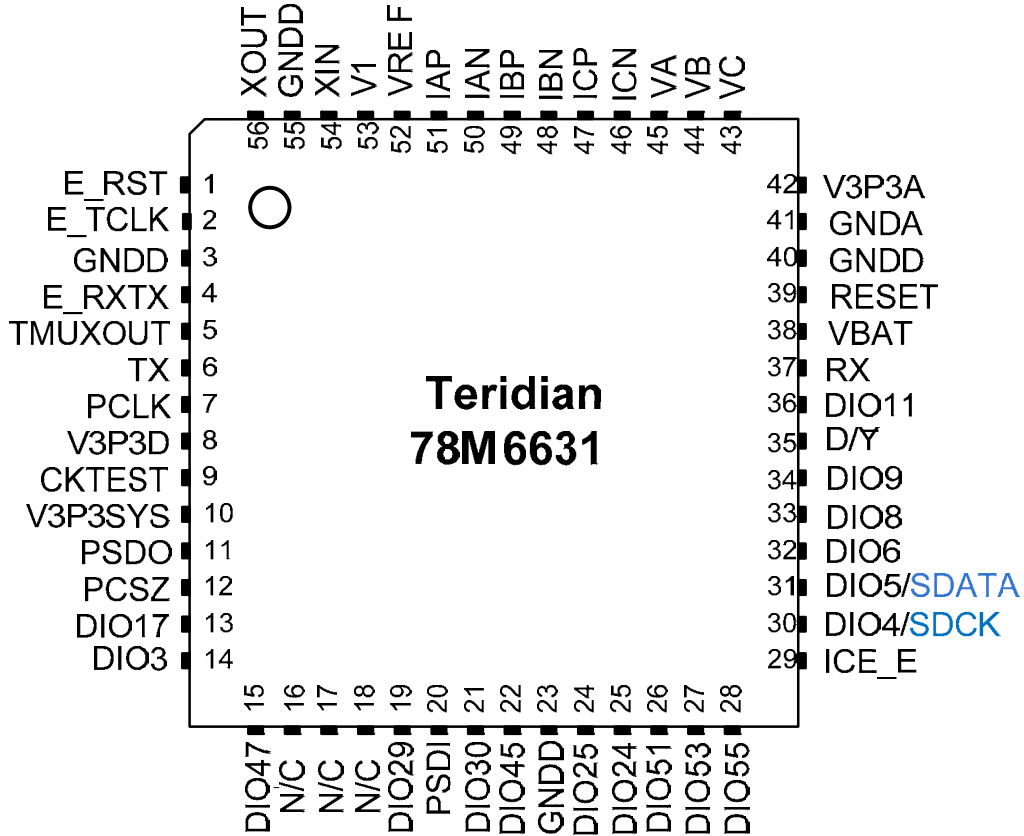
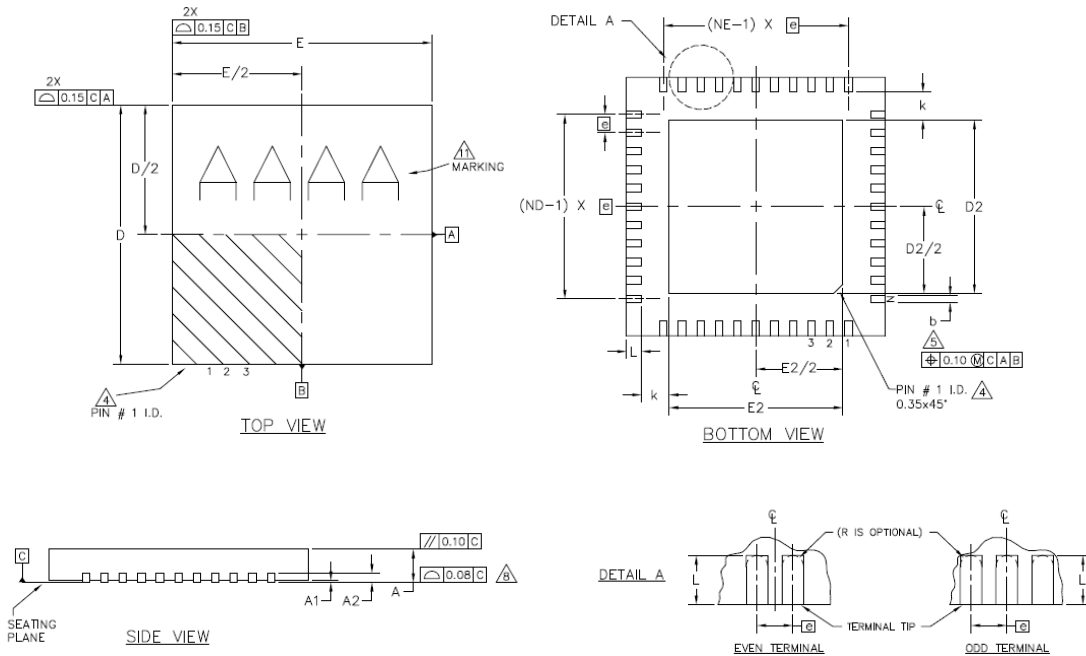

Figure 6: Pinout for QFN-56 Package

### 3.2.1 56-Pin QFN Package Outline



PKG	56L 7x7		
SYMBOL	MIN.	NOM.	MAX.
A	0.70	0.75	0.80
A1	0	-	0.05
A2	0.20 REF.		
b	0.15	0.20	0.25
D	6.90	7.00	7.10
E	6.90	7.00	7.10
e	0.40 BSC.		
k	0.25	-	-
L	0.30	0.40	0.50
N	56		
ND	14		
NE	14		

**NOTES:**

1. DIMENSIONING & TOLERANCING CONFORM TO ASME Y14.5M-1994.
2. ALL DIMENSIONS ARE IN MILLIMETERS. ANGLES ARE IN DEGREES.
3. N IS THE TOTAL NUMBER OF TERMINALS.
4. THE TERMINAL #1 IDENTIFIER AND TERMINAL NUMBERING CONVENTION SHALL CONFORM TO JESD 95-1 SPP-012. DETAILS OF TERMINAL #1 IDENTIFIER ARE OPTIONAL, BUT MUST BE LOCATED WITHIN THE ZONE INDICATED. THE TERMINAL #1 IDENTIFIER MAY BE EITHER A MOLD OR MARKED FEATURE.
5. DIMENSION b APPLIES TO METALLIZED TERMINAL AND IS MEASURED BETWEEN 0.25 mm AND 0.30 mm FROM TERMINAL TIP.
6. ND AND NE REFER TO THE NUMBER OF TERMINALS ON EACH D AND E SIDE RESPECTIVELY.
7. DEPOPULATION IS POSSIBLE IN A SYMMETRICAL FASHION.
8. COPLANARITY APPLIES TO THE EXPOSED HEAT SINK SLUG AS WELL AS THE TERMINALS.
9. DRAWING CONFORMS TO JEDEC MO220 EXCEPT THE EXPOSED PAD DIMENSIONS OF T4877-3/-4/-6 & T5677-1.
10. WARPAGE SHALL NOT EXCEED 0.10 mm.
11. MARKING IS FOR PACKAGE ORIENTATION REFERENCE ONLY.
12. NUMBER OF LEADS SHOWN ARE FOR REFERENCE ONLY.
13. ALL DIMENSIONS APPLY TO BOTH LEADED (-) AND PbFREE (+) PKG. CODES.

### 3.2.2 Recommended PCB Land Pattern for the QFN-56 Package

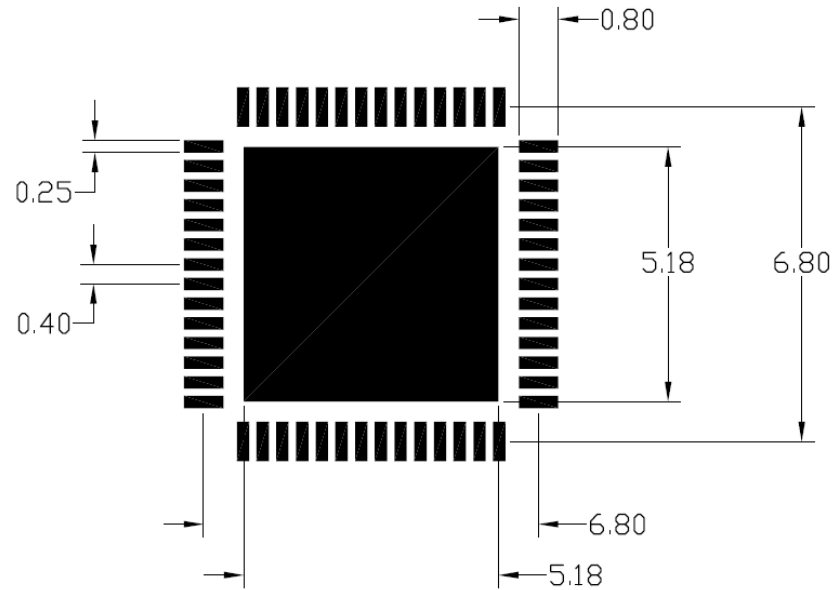
**NOTES:**

1. REFERENCE PKG. OUTLINE: 21-0144
2. LAND PATTERN COMPLIES TO: IPC7351A.
3. TOLERANCE:  $\pm 0.02$  MM.
4. ALL DIMENSIONS APPLY TO BOTH LEADED (-) AND P<sub>b</sub>FREE (+) PKG. CODES.
5. ALL DIMENSIONS IN MM.

**Figure 7: PCB Land Pattern for QFN-56 Package**

## 4 Pin Descriptions

### 4.1 Power and Ground Pins

Table 18: Power and Ground Pins

Name	Type	Circuit	Description
GNDA	P	–	Analog ground: This pin should be connected directly to the ground plane.
GNDD	P	–	Digital ground: This pin should be connected directly to the ground plane.
V3P3A	P	–	Analog power supply: A 3.3 V power supply should be connected to this pin, must be the same voltage as V3P3SYS.
V3P3D	P	–	System 3.3 V supply. This pin should be connected to a 3.3 V power supply.

### 4.2 Analog Pins

Table 19: Analog Pins

Name	Type	Circuit	Description
IAP, IAN, IBP, IBN, ICP, ICN	I	6	Line Current Sense Inputs: These pins are voltage inputs to the internal A/D converter. Typically, they are connected to the outputs of current sensors. <b>Unused pins must be connected to V3P3A.</b>
VA, VB, VC	I	6	Line Voltage Sense Inputs: These pins are voltage inputs to the internal A/D converter. Typically, they are connected to the outputs of resistor dividers. <b>Unused pins must be connected to V3P3A.</b>
V1	I	7	Comparator Input: This pin is a voltage input to the internal comparator. The voltage applied to the pin is compared to the internal BIAS voltage (1.6 V). If the input voltage is above VBIAS, the comparator output is high (1). If the comparator output is low, a voltage fault occurs. A series 5 k $\Omega$ resistor should be connected from V1 to the resistor divider.
VREF	O	9	Voltage Reference for the ADC. Normally disabled and left unconnected. If enabled, a 0.1 $\mu$ F capacitor to V3P3A should be connected to this pin.
XIN XOUT	I	8	Crystal Inputs: A 32 kHz crystal should be connected across these pins. Typically, a 33 pF capacitor is also connected from XIN to GNDA and a 15 pF capacitor is connected from XOUT to GNDA. It is important to minimize the capacitance between these pins. Refer to the crystal manufacturer data sheet for details. If an external clock is used, a 150 mV <sub>P-P</sub> clock signal should be applied to XIN, and XOUT should be left unconnected.

<sup>1)</sup> Pin types: P = Power, O = Output, I = Input, I/O = Input/Output

The circuit number denotes the equivalent circuit, as specified under [Section 5 I/O Equivalent Circuits](#).

### 4.3 Digital Pins

Table 20: Digital Pins

Name	Type	Circuit	Description
DIO3	I/O	3, 4	Dedicated DIO pin.
DIO4, DIO5, DIO6 DIO8, DIO9, DIO11 DIO17 DIO24, DIO25 DIO29, DIO30 DIO45, DIO47 DIO51, DIO53 DIO55	I/O	3, 4, 5	Multi-use pins, DIO. (DIO4 = SCK, DIO5 = SDA when configured as EEPROM interface; <b>If unused, these pins must be configured as DIOs and set to outputs by the firmware.</b> )
D/Y	I	–	Selects either the Delta or the Wye configuration.
PCLK PSDO PCSZ PSDI	I/O	3, 4, 5	SPI PORT.
E_RXTX	I/O	1, 4, 5	Port pins (when ICE_E pulled high).
E_RST	I/O	1, 4, 5	
E_TCLK	O	4, 5	
ICE_E	I	2	ICE enable. When zero, E_RST, E_TCLK and E_RXTX SEG32 For production units, this pin should be pulled to GND to disable the emulator port.
CKTEST	I/O	3, 4	Test clock.
TMUXOUT	O	4	Digital test multiplexer output. Controlled by <i>TMUX[3:0]</i> .
RESET	I	2	Chip reset: This input pin is used to reset the chip into a known state. For normal operation, this pin is pulled low. To reset the chip, this pin should be pulled high. This pin has an internal 30 $\mu$ A (typ) current source pulldown. No external reset circuitry is necessary.
RX	I	3	UART input. <b>If this pin is unused, it must be terminated to V3P3D or GNDD.</b>
TX	O	4	UART output.
GNDD (pin 55)	I	7	Enables Production Test. <b>This pin must be grounded in normal operation.</b>

Pin types: P = Power, O = Output, I = Input, I/O = Input/Output.

The circuit number denotes the equivalent circuit, as specified in Section 5, I/O Equivalent Circuits.

## 5 I/O Equivalent Circuits

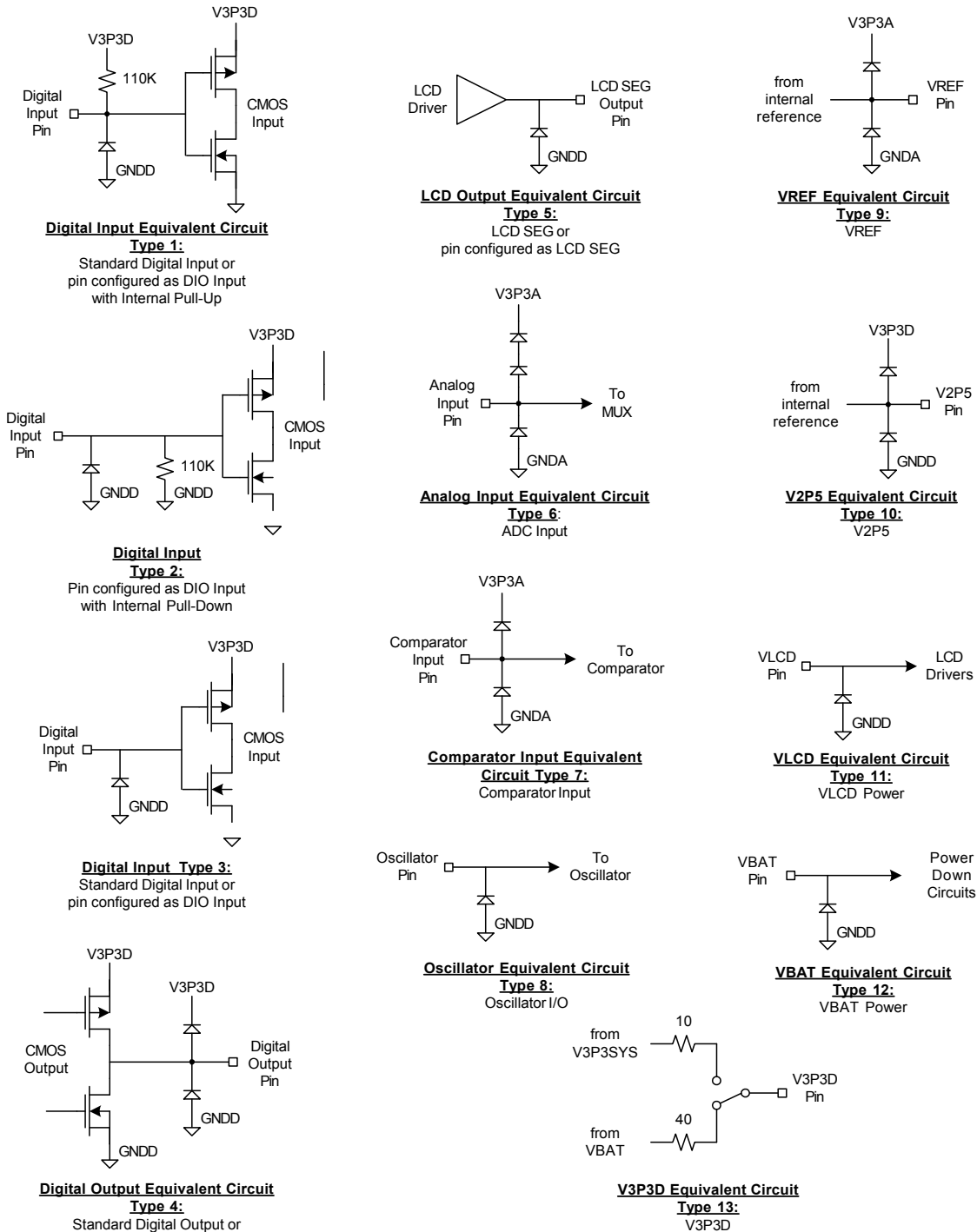

Figure 8: I/O Equivalent Circuits

## 6 Ordering Information

Table 21: Ordering Information

Part	Part Description (Package)	Flash Size	Packaging	Order Number	Package Marking
78M6631	56-pin QFN, Lead(Pb)-Free	128 KB	Bulk	78M6631-IM/F	78M6631
			Tape and Reel	78M6631-IMR/F	

## 7 Contact Information

For more information about Maxim products or to check the availability of the 78M6631, contact technical support at [www.maxim-ic.com/support](http://www.maxim-ic.com/support).

## Revision History

REVISION NUMBER	REVISION DATE	DESCRIPTION	PAGES CHANGED
0	9/11	Initial release	—
1	1/12	Removed information about programmed devices from Table 21. Ordering Information	29
2	4/12	Removed “-IM” from the Package Marking	29



*Maxim cannot assume responsibility for use of any circuitry other than circuitry entirely embodied in a Maxim product. No circuit patent licenses are implied. Maxim reserves the right to change the circuitry and specifications without notice at any time. The parametric values (min and max limits) shown in the Electrical Characteristics table are guaranteed. Other parametric values quoted in this data sheet are provided for guidance.*

## Looking for pricing, stock, or lifecycle information?

Click below to explore more details on WIN SOURCE:

 [View 78M6631-IM/F on WIN SOURCE](#)

 [Maxim Integrated Information](#)

## Optimize Your Supply Chain with WIN SOURCE Solutions

-  Global Sourcing Solution
-  Obsolete Management
-  Cost Control Management
-  Shortage Management
-  Alternative Solution
-  Excess Inventory Management