



**THE DATASHEET OF
SCAN921226SLC/NOPB**



SCAN921025 and SCAN921226 30-80 MHz 10 Bit Bus LVDS Serializer and Deserializer with IEEE 1149.1 (JTAG) and at-speed BIST

Check for Samples: [SCAN921025](#), [SCAN921226](#)

FEATURES

- **IEEE 1149.1 (JTAG) Compliant and At-Speed BIST Test Mode.**
- **Clock Recovery From PLL Lock to Random Data Patterns.**
- **Specified Transition Every Data Transfer Cycle**
- **Chipset (Tx + Rx) Power Consumption < 600 mW (typ) @ 80 MHz**
- **Single Differential Pair Eliminates Multi-Channel Skew**
- **800 Mbps Serial Bus LVDS Data Rate (At 80 MHz Clock)**
- **10-Bit Parallel Interface for 1 Byte Data Plus 2 Control Bits**
- **Synchronization Mode and LOCK Indicator**
- **Programmable Edge Trigger on Clock**
- **High Impedance on Receiver Inputs When Power is Off**
- **Bus LVDS Serial Output Rated for 27Ω Load**
- **Small 49-Lead NFBGA Package**

DESCRIPTION

The SCAN921025 transforms a 10-bit wide parallel LVCMOS/LVTTL data bus into a single high speed Bus LVDS serial data stream with embedded clock. The SCAN921226 receives the Bus LVDS serial data stream and transforms it back into a 10-bit wide parallel data bus and recovers parallel clock.

Both devices are compliant with IEEE 1149.1 Standard for Boundary Scan Test. IEEE 1149.1 features provide the design or test engineer access via a standard Test Access Port (TAP) to the backplane or cable interconnects and the ability to verify differential signal integrity. The pair of devices also features an at-speed BIST mode which allows the interconnects between the Serializer and Deserializer to be verified at-speed.

The SCAN921025 transmits data over backplanes or cable. The single differential pair data path makes PCB design easier. In addition, the reduced cable, PCB trace count, and connector size tremendously reduce cost. Since one output transmits clock and data bits serially, it eliminates clock-to-data and data-to-data skew. The powerdown pin saves power by reducing supply current when not using either device. Upon power up of the Serializer, you can choose to activate synchronization mode or allow the Deserializer to use the synchronization-to-random-data feature. By using the synchronization mode, the Deserializer will establish lock to a signal within specified lock times. In addition, the embedded clock ensures a transition on the bus every 12-bit cycle. This eliminates transmission errors due to charged cable conditions. Furthermore, you may put the SCAN921025 output pins into Tri-state to achieve a high impedance state. The PLL can lock to frequencies between 30 MHz and 80 MHz.



Please be aware that an important notice concerning availability, standard warranty, and use in critical applications of Texas Instruments semiconductor products and disclaimers thereto appears at the end of this data sheet.

All trademarks are the property of their respective owners.

Block Diagrams

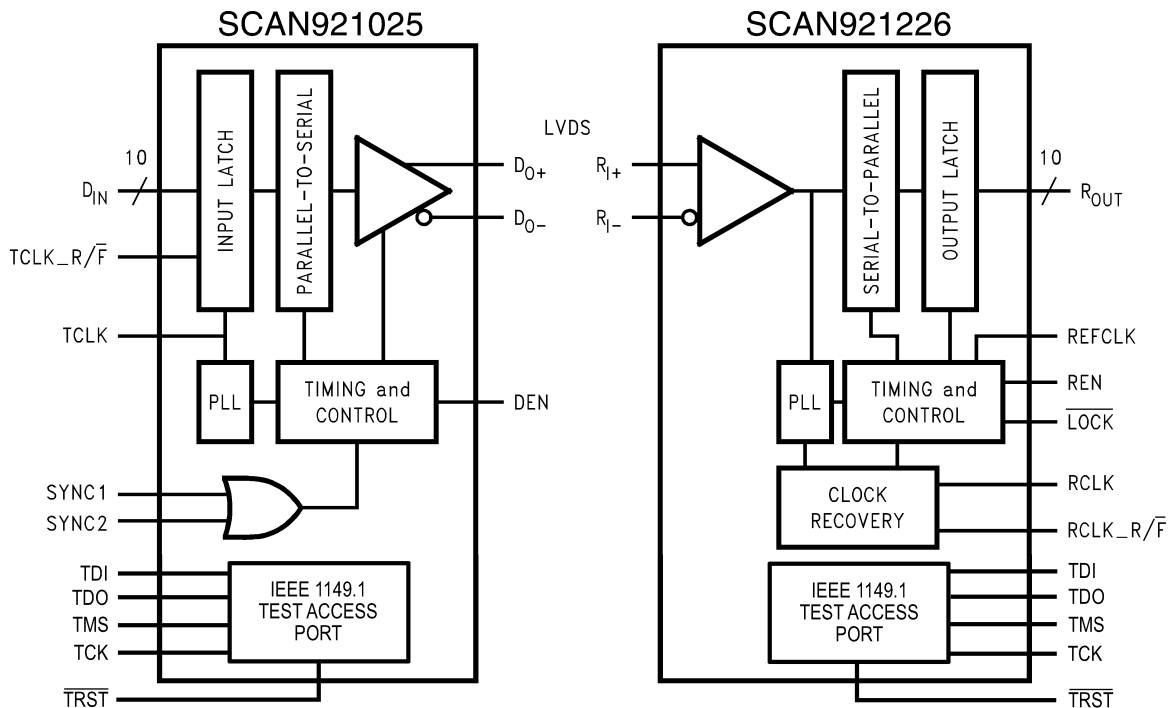

Application

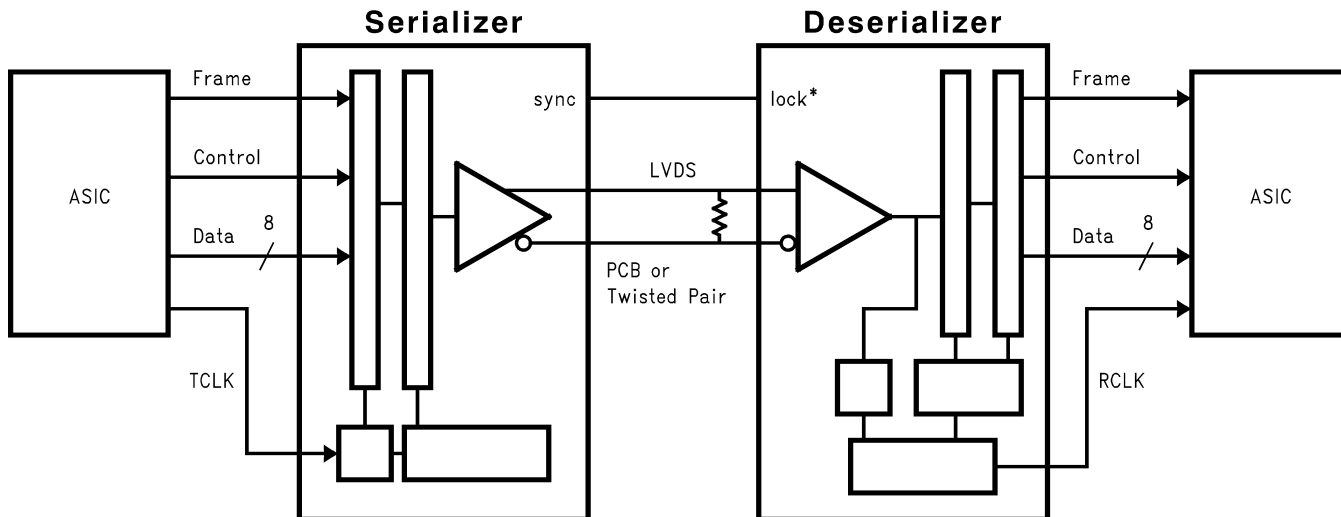

FUNCTIONAL DESCRIPTION

The SCAN921025 and SCAN921226 are a 10-bit Serializer and Deserializer chipset designed to transmit data over differential backplanes at clock speeds from 30 to 80 MHz. The chipset is also capable of driving data over Unshielded Twisted Pair (UTP) cable.

The chipset has three active states of operation: [Initialization](#), [Data Transfer](#), and [Resynchronization](#); and two passive states: [Powerdown](#) and [TRI-STATE](#). In addition to the active and passive states, there are also test modes for JTAG access and at-speed BIST.

The following sections describe each operation and passive state and the test modes.

Initialization

Initialization of both devices must occur before data transmission begins. Initialization refers to synchronization of the Serializer and Deserializer PLL's to local clocks, which may be the same or separate. Afterwards, synchronization of the Deserializer to Serializer occurs.

Step 1: When you apply V_{CC} to both Serializer and/or Deserializer, the respective outputs enter TRI-STATE, and on-chip power-on circuitry disables internal circuitry. When V_{CC} reaches V_{CCOK} (2.5V) the PLL in each device begins locking to a local clock. For the Serializer, the local clock is the transmit clock (TCLK) provided by the source ASIC or other device. For the Deserializer, you must apply a local clock to the REFCLK pin.

The Serializer outputs remain in TRI-STATE while the PLL locks to the TCLK. After locking to TCLK, the Serializer is now ready to send data or SYNC patterns, depending on the levels of the SYNC1 and SYNC2 inputs or a data stream. The SYNC pattern sent by the Serializer consists of six ones and six zeros switching at the input clock rate.

Note that the Deserializer \overline{LOCK} output will remain high while its PLL locks to the incoming data or to SYNC patterns on the input.

Step 2: The Deserializer PLL must synchronize to the Serializer to complete initialization. The Deserializer will lock to non-repetitive data patterns. However, the transmission of SYNC patterns enables the Deserializer to lock to the Serializer signal within a specified time. See [Figure 11](#).

The user's application determines control of the SYNC1 and SYNC 2 pins. One recommendation is a direct feedback loop from the \overline{LOCK} pin. Under all circumstances, the Serializer stops sending SYNC patterns after both SYNC inputs return low.

When the Deserializer detects edge transitions at the Bus LVDS input, it will attempt to lock to the embedded clock information. When the Deserializer locks to the Bus LVDS clock, the \overline{LOCK} output will go low. When \overline{LOCK} is low, the Deserializer outputs represent incoming Bus LVDS data.

Data Transfer

After initialization, the Serializer will accept data from inputs DIN0–DIN9. The Serializer uses the TCLK input to latch incoming Data. The TCLK_R/F pin selects which edge the Serializer uses to strobe incoming data. TCLK_R/F high selects the rising edge for clocking data and low selects the falling edge. If either of the SYNC inputs is high for $5 \cdot TCLK$ cycles, the data at DIN0–DIN9 is ignored regardless of clock edge.

After determining which clock edge to use, a start and stop bit, appended internally, frame the data bits in the register. The start bit is always high and the stop bit is always low. The start and stop bits function as the embedded clock bits in the serial stream.

The Serializer transmits serialized data and clock bits (10+2 bits) from the serial data output (DO_{\pm}) at 12 times the TCLK frequency. For example, if TCLK is 80 MHz, the serial rate is $80 \times 12 = 960$ Mega-bits-per-second. Since only 10 bits are from input data, the serial "payload" rate is 10 times the TCLK frequency. For instance, if TCLK = 80 MHz, the payload data rate is $80 \times 10 = 800$ Mbps. The data source provides TCLK and must be in the range of 30 MHz to 80 MHz nominal.

The Serializer outputs (DO_{\pm}) can drive a point-to-point connection or in limited multi-point or multi-drop backplanes. The outputs transmit data when the enable pin (DEN) is high, $PWRDN = high$, and SYNC1 and SYNC2 are low. When DEN is driven low, the Serializer output pins will enter TRI-STATE.

When the Deserializer synchronizes to the Serializer, the $\overline{\text{LOCK}}$ pin is low. The Deserializer locks to the embedded clock and uses it to recover the serialized data. ROUT data is valid when $\overline{\text{LOCK}}$ is low. Otherwise ROUT0–ROUT9 is invalid.

The ROUT0–ROUT9 pins use the RCLK pin as the reference to data. The polarity of the RCLK edge is controlled by the RCLK_R/F input. See [Figure 15](#).

ROUT(0-9), $\overline{\text{LOCK}}$ and RCLK outputs will drive a maximum of three CMOS input gates (15 pF load) with a 80 MHz clock.

Resynchronization

When the Deserializer PLL locks to the embedded clock edge, the Deserializer $\overline{\text{LOCK}}$ pin asserts a low. If the Deserializer loses lock, the $\overline{\text{LOCK}}$ pin output will go high and the outputs (including RCLK) will enter TRI-STATE.

The user's system monitors the $\overline{\text{LOCK}}$ pin to detect a loss of synchronization. Upon detection, the system can arrange to pulse the Serializer SYNC1 or SYNC2 pin to resynchronize. Multiple resynchronization approaches are possible. One recommendation is to provide a feedback loop using the $\overline{\text{LOCK}}$ pin itself to control the sync request of the Serializer (SYNC1 or SYNC2). Dual SYNC pins are provided for multiple control in a multi-drop application. Sending sync patterns for resynchronization is desirable when lock times within a specific time are critical. However, the Deserializer can lock to random data, which is discussed in the next section.

Random Lock Initialization and Resynchronization

The initialization and resynchronization methods described in their respective sections are the fastest ways to establish the link between the Serializer and Deserializer. However, the SCAN921226 can attain lock to a data stream without requiring the Serializer to send special SYNC patterns. This allows the SCAN921226 to operate in “open-loop” applications. Equally important is the Deserializer's ability to support hot insertion into a running backplane. In the open loop or hot insertion case, we assume the data stream is essentially random. Therefore, because lock time varies due to data stream characteristics, we cannot possibly predict exact lock time. However, please see [Table 1](#) for some general random lock times under specific conditions. The primary constraint on the “random” lock time is the initial phase relation between the incoming data and the REFCLK when the Deserializer powers up. As described in the next paragraph, the data contained in the data stream can also affect lock time.

If a specific pattern is repetitive, the Deserializer could enter “false lock” - falsely recognizing the data pattern as the clocking bits. We refer to such a pattern as a repetitive multi-transition, RMT. This occurs when more than one Low-High transition takes place in a clock cycle over multiple cycles. This occurs when any bit, except DIN 9, is held at a low state and the adjacent bit is held high, creating a 0-1 transition. In the worst case, the Deserializer could become locked to the data pattern rather than the clock. Circuitry within the SCAN921226 can detect that the possibility of “false lock” exists. The circuitry accomplishes this by detecting more than one potential position for clocking bits. Upon detection, the circuitry will prevent the $\overline{\text{LOCK}}$ output from becoming active until the potential “false lock” pattern changes. The false lock detect circuitry expects the data will eventually change, causing the Deserializer to lose lock to the data pattern and then continue searching for clock bits in the serial data stream. Graphical representations of RMT are shown in [Figure 3](#). Please note that RMT only applies to bits DIN0–DIN8.

Powerdown

When no data transfer occurs, you can use the Powerdown state. The Serializer and Deserializer use the Powerdown state, a low power sleep mode, to reduce power consumption. The Deserializer enters Powerdown when you drive $\overline{\text{PWRDN}}$ and REN low. The Serializer enters Powerdown when you drive $\overline{\text{PWRDN}}$ low. In Powerdown, the PLL stops and the outputs enter TRI-STATE, which disables load current and reduces supply current to the milliampere range. To exit Powerdown, you must drive the $\overline{\text{PWRDN}}$ pin high.

Before valid data exchanges between the Serializer and Deserializer, you must reinitialize and resynchronize the devices to each other. Initialization of the Serializer takes 510 TCLK cycles. The Deserializer will initialize and assert $\overline{\text{LOCK}}$ high until lock to the Bus LVDS clock occurs.

TRI-STATE

The Serializer enters TRI-STATE when the DEN pin is driven low. This puts both driver output pins (DO+ and DO-) into TRI-STATE. When you drive DEN high, the Serializer returns to the previous state, as long as all other control pins remain static (SYNC1, SYNC2, PWRDN, TCLK_R/F).

When you drive the REN pin low, the Deserializer enters TRI-STATE. Consequently, the receiver output pins (ROUT0–ROUT9) and RCLK will enter TRI-STATE. The LOCK output remains active, reflecting the state of the PLL.

Table 1. Random Lock Times for the SCAN921226⁽¹⁾

	80 MHz	Units
Maximum	18	μs
Mean	3.0	μs
Minimum	0.43	μs
Conditions:	PRBS 2 ¹⁵ , V _{CC} = 3.3V	

(1) Difference in lock times are due to different starting points in the data pattern with multiple parts.

Test Modes

In addition to the IEEE 1149.1 test access to the digital TTL pins, the SCAN921025 and SCAN921226 have two instructions to test the LVDS interconnects. The first is EXTEST. This is implemented at LVDS levels and is only intended as a go no-go test (e.g. missing cables). The second method is the RUNBIST instruction. It is an "at-system-speed" interconnect test. It is executed in approximately 33mS with a system clock speed of 66MHz. There are two bits in the RX BIST data register for notification of PASS/FAIL and TEST_COMPLETE. Pass indicates that the BER (Bit-Error-Rate) is better than 10⁻⁷.

An important detail is that once both devices have the RUNBIST instruction loaded into their respective instruction registers, both devices must move into the RTI state within 4K system clocks (At a SCLK of 66Mhz and TCK of 1MHz this allows for 66 TCK cycles). This is not a concern when both devices are on the same scan chain or LSP, however, it can be a problem with some multi-drop devices. This test mode has been simulated and verified using TI's SCANSTA111.

RMT Patterns Seen on the Bus LVDS Serial Output

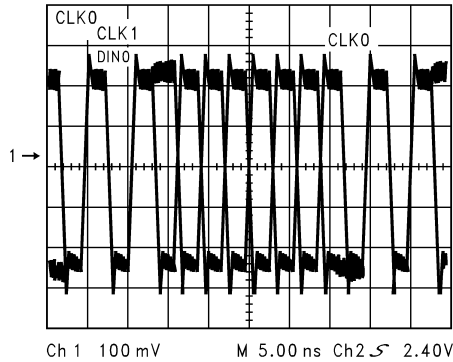

Figure 1. DIN0 Held Low-DIN1 Held High Creates an RMT Pattern

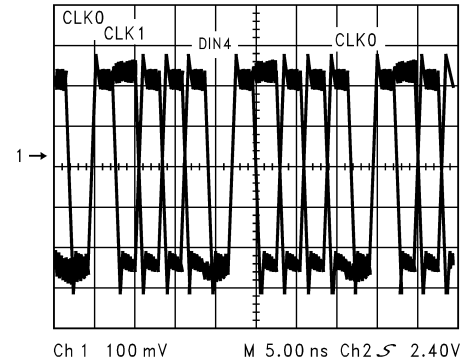

Figure 2. DIN8 Held Low-DIN9 Held High Creates an RMT Pattern

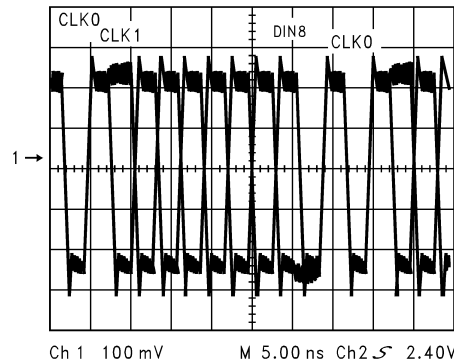

Figure 3. DIN4 Held Low-DIN5 Held High Creates an RMT Pattern



These devices have limited built-in ESD protection. The leads should be shorted together or the device placed in conductive foam during storage or handling to prevent electrostatic damage to the MOS gates.

ABSOLUTE MAXIMUM RATINGS⁽¹⁾

Supply Voltage (V_{CC})		-0.3V to +4V
LVC MOS/LVTTL Input Voltage		-0.3V to ($V_{CC} + 0.3V$)
LVC MOS/LVTTL Output Voltage		-0.3V to ($V_{CC} + 0.3V$)
Bus LVDS Receiver Input Voltage		-0.3V to +3.9V
Bus LVDS Driver Output Voltage		-0.3V to +3.9V
Bus LVDS Output Short Circuit Duration		10mS
Junction Temperature		+150°C
Storage Temperature		-65°C to +150°C
Lead Temperature (Soldering, 4 seconds)		+220°C
Maximum Package Power Dissipation Capacity @ 25°C Package:	49L NFBGA	1.47 W
Package Derating:	49L NFBGA	11.8 mW/°C above +25°C
	θ_{ja}	85°C/W
ESD Rating	HBM	>2kV
	MM	> 250V

(1) Absolute Maximum Ratings are those values beyond which the safety of the device cannot be ensured. They are not meant to imply that the devices should be operated at these limits. The table of [Electrical Characteristics](#) specifies conditions of device operation.

RECOMMENDED OPERATING CONDITIONS

	Min	Nom	Max	Units
Supply Voltage (V_{CC})	3.0	3.3	3.6	V
Operating Free Air Temperature (T_A)	-40	+25	+85	°C
Receiver Input Range	0		2.4	V
Supply Noise Voltage (V_{CC})				100 mV _{P-P}

ELECTRICAL CHARACTERISTICS

Over recommended operating supply and temperature ranges unless otherwise specified.

Symbol	Parameter	Conditions	Min	Typ	Max	Units
SERIALIZER LVCMOS/LVTTL DC SPECIFICATIONS (apply to DIN0-9, TCLK, PWRDN, TCLK_R/F, SYNC1, SYNC2, DEN)						
V_{IH}	High Level Input Voltage		2.0		V_{CC}	V
V_{IL}	Low Level Input Voltage		GND		0.8	V
V_{CL}	Input Clamp Voltage	$I_{CL} = -18$ mA		-0.86	-1.5	V
I_{IN}	Input Current	$V_{IN} = 0V$ or 3.6V	-10	±1	+10	µA
DESERIALIZER LVCMOS/LVTTL DC SPECIFICATIONS (apply to pins PWRDN, RCLK_R/F, REN, REFCLK = inputs; apply to pins ROUT, RCLK, LOCK = outputs)						
V_{IH}	High Level Input Voltage		2.0		V_{CC}	V
V_{IL}	Low Level Input Voltage		GND		0.8	V
V_{CL}	Input Clamp Voltage	$I_{CL} = -18$ mA		-0.62	-1.5	V
I_{IN}	Input Current	$V_{IN} = 0V$ or 3.6V	-10	±1	+15	µA
V_{OH}	High Level Output Voltage	$I_{OH} = -9$ mA	2.2	3.0	V_{CC}	V
V_{OL}	Low Level Output Voltage	$I_{OL} = 9$ mA	GND	0.25	0.5	V
I_{OS}	Output Short Circuit Current	$V_{OUT} = 0V$	-15	-47	-85	mA
I_{OS}	Output Short Circuit Current, TDO output		-15	-70	-100	mA
I_{OZ}	TRI-STATE Output Current	\overline{PWRDN} or $REN = 0.8V$, $V_{OUT} = 0V$ or V_{CC}	-10	±0.1	+10	µA
SERIALIZER Bus LVDS DC SPECIFICATIONS (apply to pins DO+ and DO-)						
V_{OD}	Output Differential Voltage (DO+)-(DO-)	$RL = 27\Omega$, see Figure 19	200	290		mV
ΔV_{OD}	Output Differential Voltage Unbalance				35	mV
V_{OS}	Offset Voltage		1.05	1.1	1.3	V
ΔV_{OS}	Offset Voltage Unbalance			4.8	35	mV
I_{OS}	Output Short Circuit Current	$D0 = 0V$, $DIN = High$, \overline{PWRDN} and $DEN = 2.4V$		-56	-90	mA
I_{OZ}	TRI-STATE Output Current	\overline{PWRDN} or $DEN = 0.8V$, $DO = 0V$ or V_{CC}	-10	±1	+10	µA
I_{OX}	Power-Off Output Current	$V_{CC} = 0V$, $DO = 0V$ or 3.6V	-20	±1	+25	µA
DESERIALIZER Bus LVDS DC SPECIFICATIONS (apply to pins RI+ and RI-)						
V_{TH}	Differential Threshold High Voltage	$V_{CM} = +1.1V$		+6	+50	mV
V_{TL}	Differential Threshold Low Voltage		-50	-12		mV
I_{IN}	Input Current	$V_{IN} = +2.4V$, $V_{CC} = 3.6V$ or $0V$	-10	±1	+10	µA
		$V_{IN} = 0V$, $V_{CC} = 3.6V$ or $0V$	-10	±0.05	+10	µA
SERIALIZER SUPPLY CURRENT (apply to pins DVCC and AVCC)						
I_{CCD}	Serializer Supply Current	$RL = 27\Omega$		45	60	mA
	Worst Case	See Figure 4	$f = 30$ MHz			
			$f = 80$ MHz	90	105	mA
I_{CCXD}	Serializer Supply Current Powerdown	$\overline{PWRDN} = 0.8V$, $f = 80$ MHz		0.2	1.0	mA
DESERIALIZER SUPPLY CURRENT (apply to pins DVCC and AVCC)						
I_{CCR}	Deserializer Supply Current	$C_L = 15$ pF		50	75	mA
	Worst Case	See Figure 5	$f = 30$ MHz			
			$f = 80$ MHz	100	120	mA
I_{CCXR}	Deserializer Supply Current Powerdown	$\overline{PWRDN} = 0.8V$, $REN = 0.8V$		0.36	1.0	mA

ELECTRICAL CHARACTERISTICS (continued)

Over recommended operating supply and temperature ranges unless otherwise specified.

Symbol	Parameter	Conditions	Min	Typ	Max	Units
SCAN CIRCUITRY DC SPECIFICATIONS, SERIALIZER AND DESERIALIZER (applies to SCAN pins as noted)						
V _{IH}	High Level Input Voltage	V _{CC} = 3.0 to 3.6V, pins TCK, TMS, TDI, and TRST	2.0		V _{CC}	V
V _{IL}	Low Level Input Voltage	V _{CC} = 3.0 to 3.6V, pins TCK, TMS, TDI, and TRST	GND		0.8	V
V _{CL}	Input Clamp Voltage	V _{CC} = 3.0V, I _{CL} = -18 mA, pins TCK, TMS, TDI, and TRST		-0.85	-1.5	V
I _{IH}	Input Current	V _{CC} = 3.6V, V _{IN} = 3.6V, pins TCK, TMS, TDI, and TRST		1	+10	μA
I _{IL}	Input Current	V _{CC} = 3.6V, V _{IN} = 0.0V, TCK Input	-10	-1		μA
I _{ILR}	Input Current	V _{CC} = 3.6V, V _{IN} = 0V, pins TMS, TDI, and TRST	-20	-10		μA
V _{OH}	High Level Output Voltage	V _{CC} = 3.0V, I _{OH} = -12 mA, TDO output	2.2	2.6		V
V _{OL}	Low Level Output Voltage	V _{CC} = 3.0V, I _{OL} = 12 mA, TDO output		0.3	0.5	V
I _{OS}	Output Short Circuit Current	V _{CC} = 3.6V, V _{OUT} = 0.0V, TDO output	-15	-90	-120	mA
I _{OZ}	TRI-STATE Output Current	PWRDN or REN = 0.8V, V _{OUT} = 0V or VCC	-10	0	+10	μA

SERIALIZER TIMING REQUIREMENTS FOR TCLK

Over recommended operating supply and temperature ranges unless otherwise specified.

Symbol	Parameter	Conditions	Min	Typ	Max	Units
t _{TCP}	Transmit Clock Period		12.5	T	33.3	ns
t _{TCIH}	Transmit Clock High Time		0.4T	0.5T	0.6T	ns
t _{TCIL}	Transmit Clock Low Time		0.4T	0.5T	0.6T	ns
t _{CLKT}	TCLK Input Transition Time			3	6	ns
t _{JIT}	TCLK Input Jitter				150	ps (RMS)

SERIALIZER SWITCHING CHARACTERISTICS

Over recommended operating supply and temperature ranges unless otherwise specified.

Symbol	Parameter	Conditions	Min	Typ	Max	Units
t _{LLHT}	Bus LVDS Low-to-High Transition Time	R _L = 27Ω C _L = 10pF to GND ⁽¹⁾ See Figure 6		0.2	0.4	ns
t _{LHLT}	Bus LVDS High-to-Low Transition Time			0.25	0.4	ns
t _{DIS}	DIN (0-9) Setup to TCLK	R _L = 27Ω, C _L = 10pF to GND See Figure 9	0			ns
t _{DIH}	DIN (0-9) Hold from TCLK		4.0			ns
t _{HZD}	DO ± HIGH to TRI-STATE Delay	R _L = 27Ω, C _L = 10pF to GND ⁽²⁾ See Figure 10		3	10	ns
t _{LZD}	DO ± LOW to TRI-STATE Delay			3	10	ns
t _{ZHD}	DO ± TRI-STATE to HIGH Delay			5	10	ns
t _{ZLD}	DO ± TRI-STATE to LOW Delay			6.5	10	ns
t _{SPW}	SYNC Pulse Width	R _L = 27Ω See Figure 12	5*t _{TCP}			ns
t _{PLD}	Serializer PLL Lock Time		510*t _{TCP}		513*t _{TCP}	ns
t _{SD}	Serializer Delay	R _{LLHT} = 27Ω, see Figure 13	t _{TCP} + 1.0	t _{TCP} + 2.5	t _{TCP} + 3.5	ns

(1) t_{LLHT} and t_{LHLT} specifications are specified by design using statistical analysis.

(2) Because the Serializer is in TRI-STATE mode, the Deserializer will lose PLL lock and have to resynchronize before data transfer.

SERIALIZER SWITCHING CHARACTERISTICS (continued)

Over recommended operating supply and temperature ranges unless otherwise specified.

Symbol	Parameter	Conditions		Min	Typ	Max	Units
t_{DJIT}	Deterministic Jitter	$R_L = 27\Omega$, $C_L = 10\text{pF}$ to GND ⁽³⁾	80 MHz	-130	-40	+60	ps
t_{RJIT}	Random Jitter				6	10	ps (RMS)

(3) t_{DJIT} specifications are specified by design using statistical analysis.

DESERIALIZER TIMING REQUIREMENTS FOR REFCLK

Over recommended operating supply and temperature ranges unless otherwise specified.

Symbol	Parameter	Conditions	Min	Typ	Max	Units
t_{RFCP}	REFCLK Period		12.5	T	33.3	ns
t_{RFDC}	REFCLK Duty Cycle		30	50	70	%
t_{RFCP} / t_{TCP}	Ratio of REFCLK to TCLK		95	1	105	
t_{RFTT}	REFCLK Transition Time			3	6	ns

DESERIALIZER SWITCHING CHARACTERISTICS

Over recommended operating supply and temperature ranges unless otherwise specified.

Symbol	Parameter	Conditions	Pin/Freq.	Min	Typ	Max	Units
t_{RCP}	Receiver out Clock Period	$t_{RCP} = t_{TCP}$ See Figure 13	RCLK	12.5		33.3	ns
t_{CLH}	CMOS/TTL Low-to-High Transition Time	CL = 15 pF See Figure 7	Rout(0-9), LOCK RCLK		1.2	4	ns
t_{CHL}	CMOS/TTL High-to-Low Transition Time				1.1	4	ns
t_{DD}	Deserialzer Delay See Figure 14	All Temp./ All Freq.		$1.75 \cdot t_{RCP} + 1.25$	$1.75 \cdot t_{RCP} + 5.0$	$1.75 \cdot t_{RCP} + 8.5$	ns
		Room Temp./3.3V/30MHz		$1.75 \cdot t_{RCP} + 2.25$	$1.75 \cdot t_{RCP} + 5.0$	$1.75 \cdot t_{RCP} + 8.0$	ns
		Room Temp./3.3V/80MHz		$1.75 \cdot t_{RCP} + 2.25$	$1.75 \cdot t_{RCP} + 5.0$	$1.75 \cdot t_{RCP} + 8.0$	ns
t_{ROS}	ROUT Data Valid before RCLK	See Figure 15	RCLK 30 MHz	$0.4 \cdot t_{RCP}$	$0.5 \cdot t_{RCP}$		ns
			RCLK 80 MHz	$0.35 \cdot t_{RCP}$	$0.5 \cdot t_{RCP}$		ns
t_{ROH}	ROUT Data valid after RCLK		30 MHz	$-0.4 \cdot t_{RCP}$	$-0.5 \cdot t_{RCP}$		ns
			80 MHz	$-0.35 \cdot t_{RCP}$	$-0.5 \cdot t_{RCP}$		ns
t_{RDC}	RCLK Duty Cycle			45	50	55	%
t_{HZR}	HIGH to TRI-STATE Delay	See Figure 16	Rout(0-9)		2.8	10	ns
t_{LZR}	LOW to TRI-STATE Delay				2.8	10	ns
t_{ZHR}	TRI-STATE to HIGH Delay				4.2	10	ns
t_{ZLR}	TRI-STATE to LOW Delay				4.2	10	ns

DESERIALIZER SWITCHING CHARACTERISTICS (continued)

Over recommended operating supply and temperature ranges unless otherwise specified.

Symbol	Parameter	Conditions	Pin/Freq.	Min	Typ	Max	Units
t _{DSR1}	Deserializer PLL Lock Time from PWRDWN (with SYNCPAT)	See Figure 17 and Figure 18 ⁽¹⁾	30 MHz		1.7	3.5	μs
			80 MHz		1.0	2.5	μs
t _{DSR2}	Deserializer PLL Lock time from SYNCPAT		30 MHz		0.65	1.5	μs
			80 MHz		0.29	0.8	μs
t _{ZHLK}	TRI-STATE to HIGH Delay (power-up)			$\overline{\text{LOCK}}$	3.7	12	ns
t _{RNMI-R}	Ideal Noise Margin Right ⁽²⁾		See Figure 22	80 MHz			+350
t _{RNMI-L}	Ideal Noise Margin Left ⁽²⁾	See Figure 22	80 MHz	-385			ps

- (1) For the purpose of specifying deserializer PLL performance, t_{DSR1} and t_{DSR2} are specified with the REFCLK running and stable, and with specific conditions for the incoming data stream (SYNCPATs). It is recommended that the deserializer be initialized using either t_{DSR1} timing or t_{DSR2} timing. t_{DSR1} is the time required for the deserializer to indicate lock upon power-up or when leaving the power-down mode. Synchronization patterns should be sent to the device before initiating either condition. t_{DSR2} is the time required to indicate lock for the powered-up and enabled deserializer when the input (RI+ and RI-) conditions change from not receiving data to receiving synchronization patterns (SYNCPATs).
- (2) t_{RNM} is a measure of how much phase noise (jitter) the deserializer can tolerate in the incoming data stream before bit errors occur. The Deserializer Noise Margin is specified by design using statistical analysis.

Table 2. SCAN CIRCUITRY TIMING REQUIREMENTS

Symbol	Parameter	Conditions	Min	Typ	Max	Units
f _{MAX}	Maximum TCK Clock Frequency	R _L = 500Ω, C _L = 35 pF	25.0	50.0		MHz
t _S	TDI to TCK, H or L		1.0			ns
t _H	TDI to TCK, H or L		2.0			ns
t _S	TMS to TCK, H or L		2.5			ns
t _H	TMS to TCK, H or L		1.5			ns
t _W	TCK Pulse Width, H or L		10.0			ns
t _W	$\overline{\text{TRST}}$ Pulse Width, L		2.5			ns
t _{REC}	Recovery Time, $\overline{\text{TRST}}$ to TCK		2.0			ns

AC TIMING DIAGRAMS AND TEST CIRCUITS

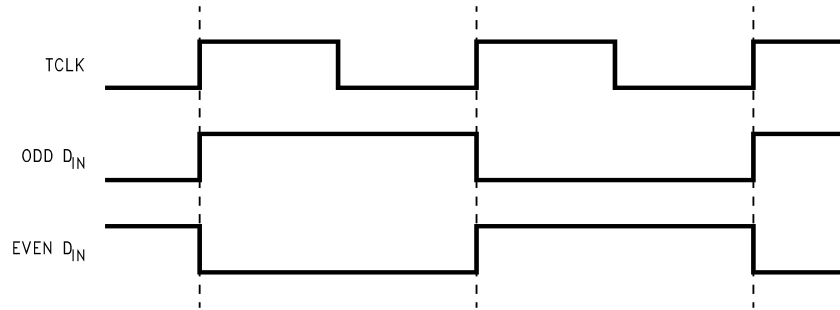

Figure 4. "Worst Case" Serializer ICC Test Pattern

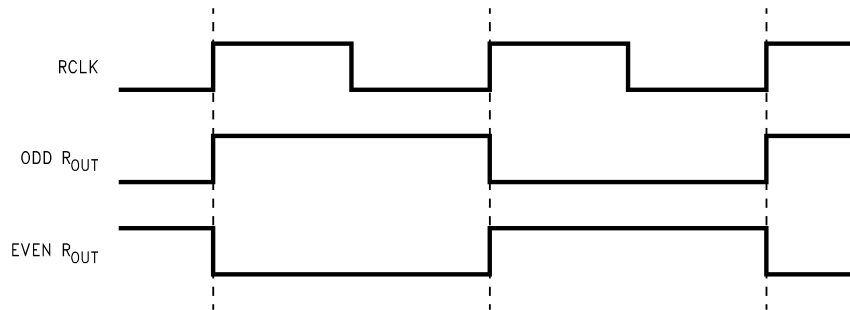

Figure 5. "Worst Case" Deserializer ICC Test Pattern

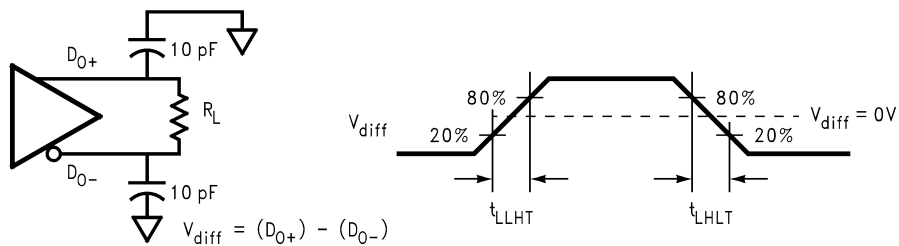

Figure 6. Serializer Bus LVDS Output Load and Transition Times

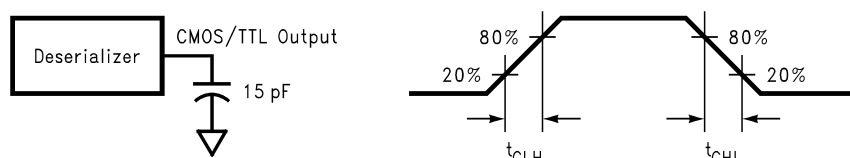

Figure 7. Deserializer CMOS/TTL Output Load and Transition Times

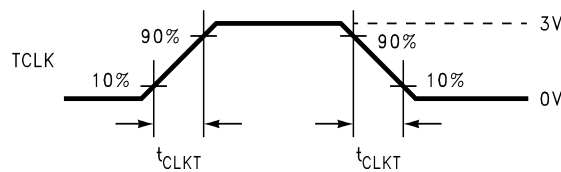
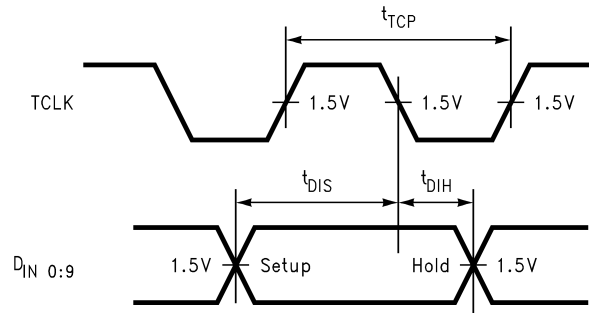
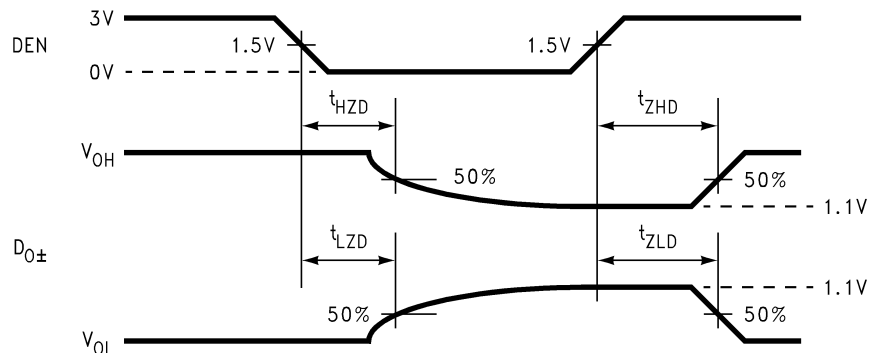
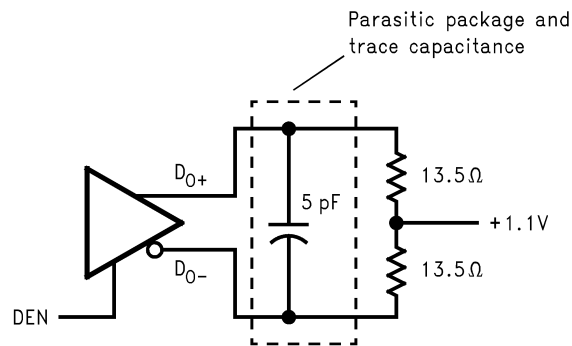
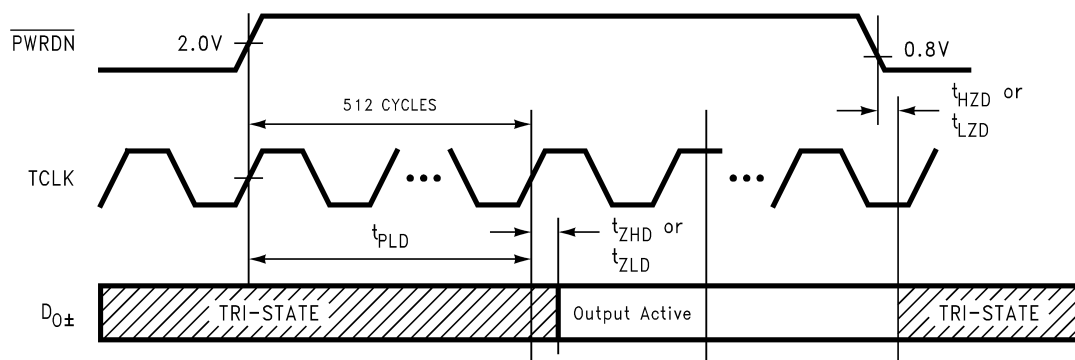

Figure 8. Serializer Input Clock Transition Time

Timing shown for $TCLK_R/\bar{F} = \text{LOW}$ **Figure 9. Serializer Setup/Hold Times****Figure 10. Serializer TRI-STATE Test Circuit and Timing****Figure 11. Serializer PLL Lock Time, and \overline{PWRDN} TRI-STATE Delays**

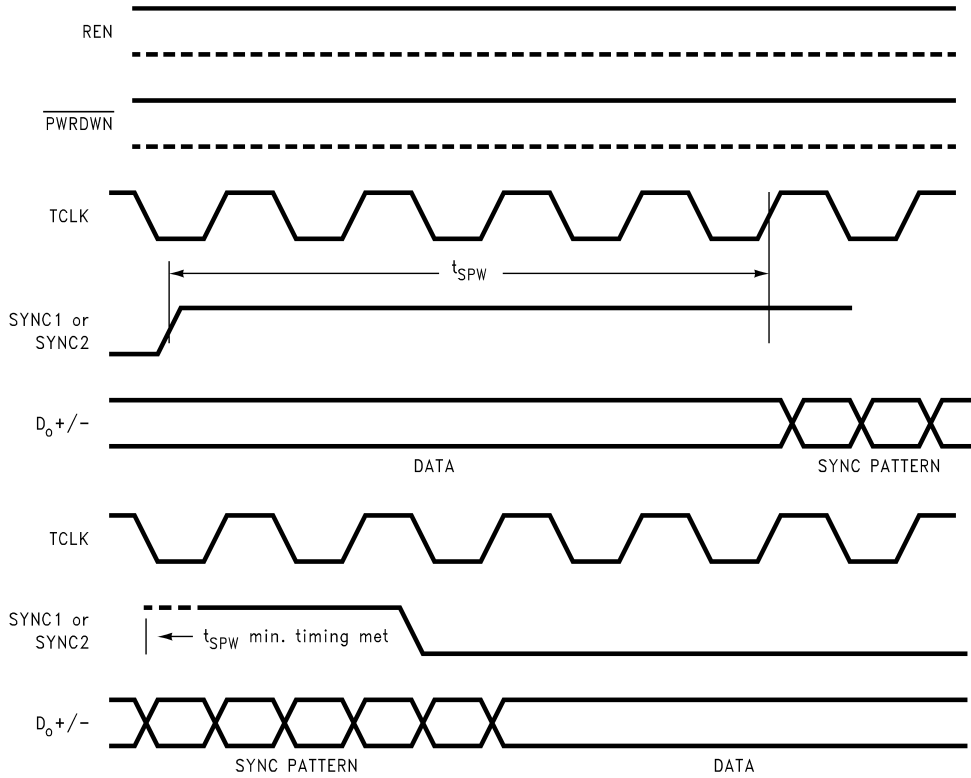

Figure 12. SYNC Timing Delays

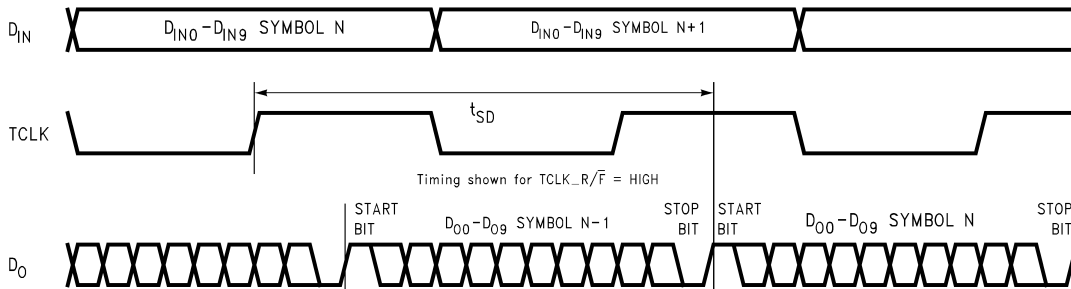

Figure 13. Serializer Delay

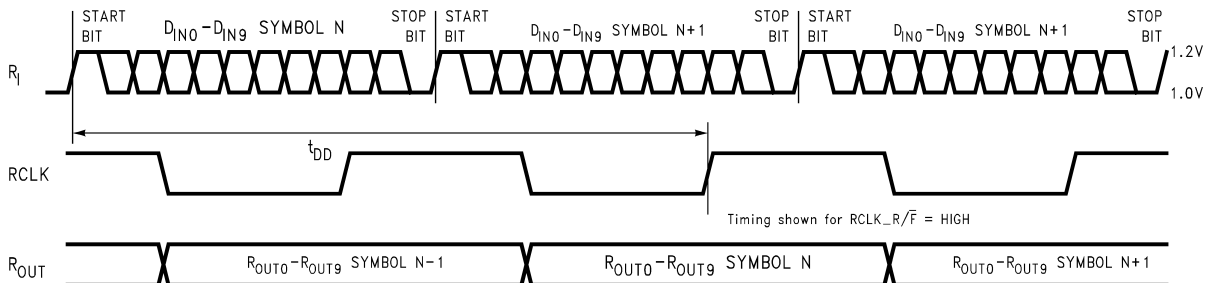

Figure 14. Deserializer Delay

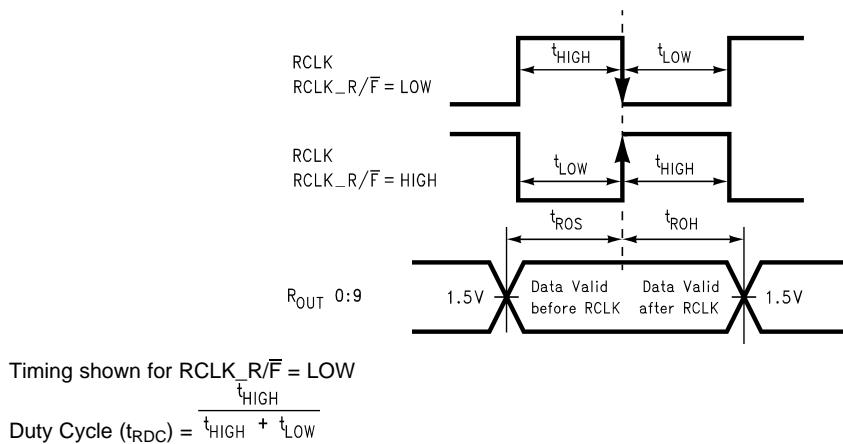

Figure 15. Deserializer Data Valid Out Times

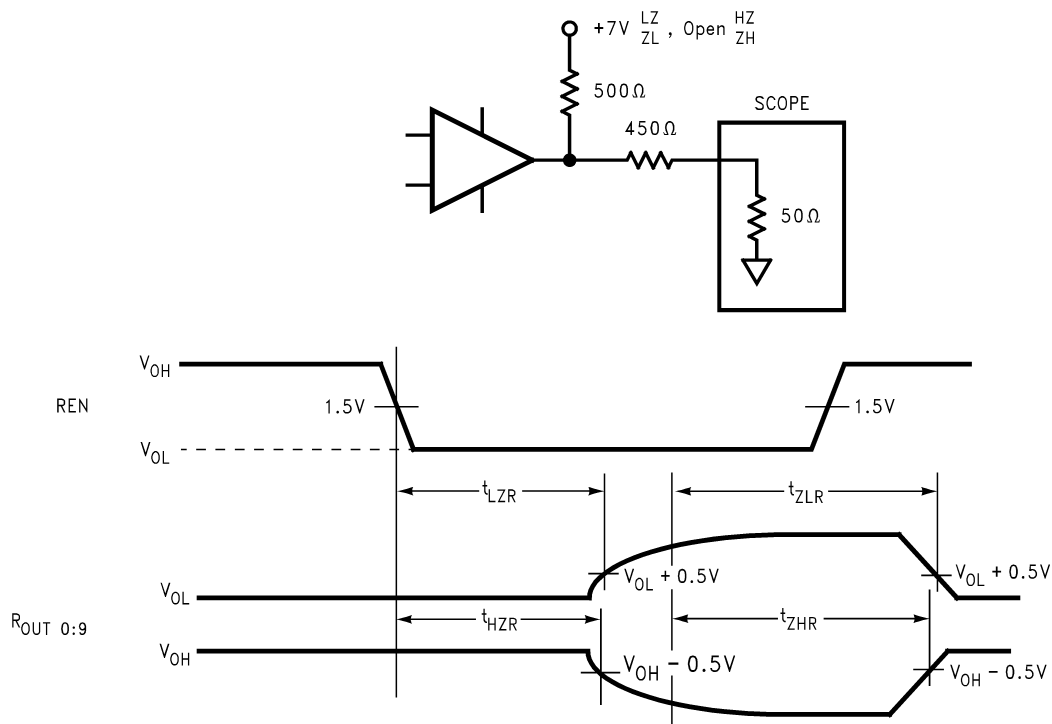

Figure 16. Deserializer TRI-STATE Test Circuit and Timing

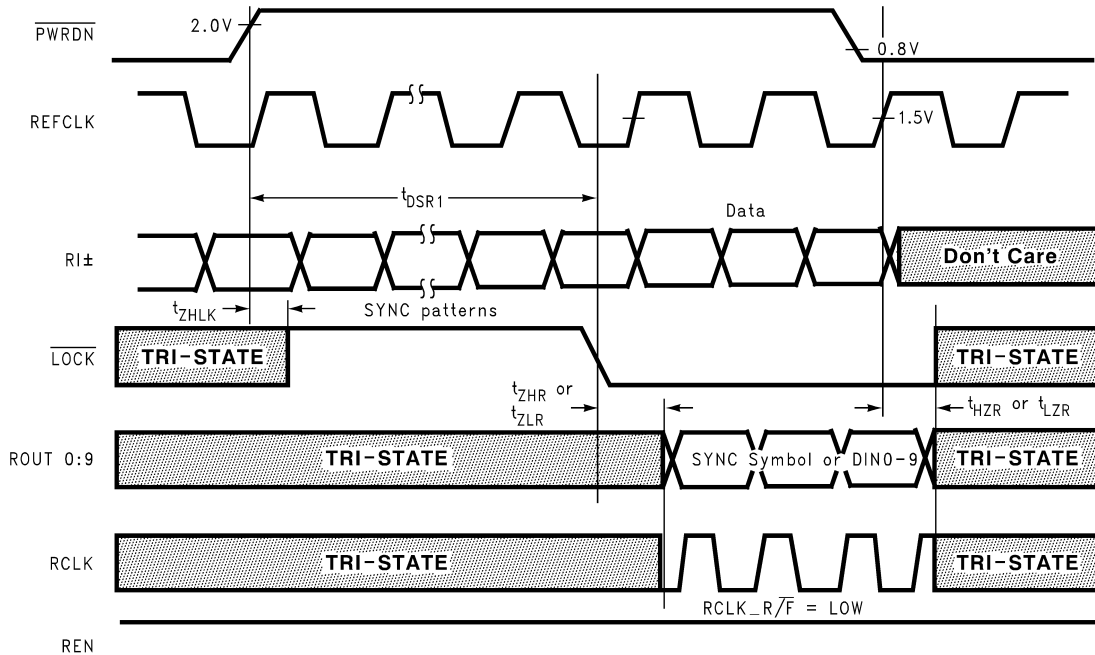

Figure 17. Deserializer PLL Lock Times and PWRDN TRI-STATE Delays

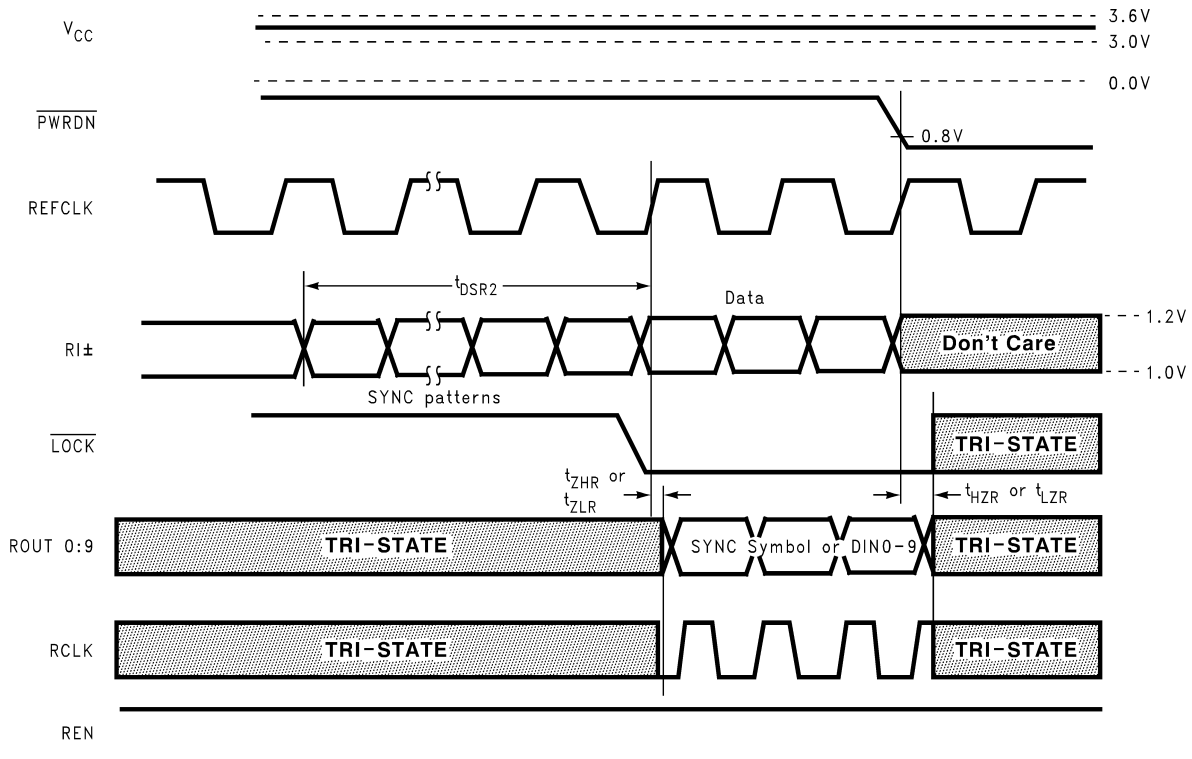
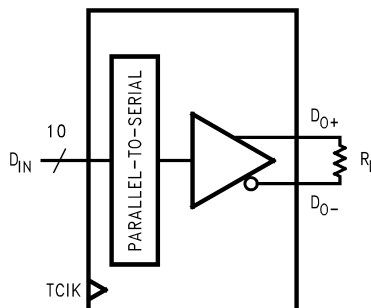

Figure 18. Deserializer PLL Lock Time from SyncPAT



$$V_{OD} = (DO^+) - (DO^-).$$

Differential output signal is shown as (DO+)-(DO-), device in Data Transfer mode.

Figure 19. V_{OD} Diagram

APPLICATION INFORMATION

USING THE SCAN921025 AND SCAN921226

The Serializer and Deserializer chipset is an easy to use transmitter and receiver pair that sends 10 bits of parallel LVTTTL data over a serial Bus LVDS link up to 800 Mbps. An on-board PLL serializes the input data and embeds two clock bits within the data stream. The Deserializer uses a separate reference clock (REFCLK) and an onboard PLL to extract the clock information from the incoming data stream and then deserialize the data. The Deserializer monitors the incoming clock information, determines lock status, and asserts the $\overline{\text{LOCK}}$ output high when loss of lock occurs.

POWER CONSIDERATIONS

An all CMOS design of the Serializer and Deserializer makes them inherently low power devices. In addition, the constant current source nature of the Bus LVDS outputs minimizes the slope of the speed vs. I_{CC} curve of conventional CMOS designs.

POWERING UP THE DESERIALIZER

The SCAN921226 can be powered up at any time by following the proper sequence. The REFCLK input can be running before the Deserializer powers up, and it must be running in order for the Deserializer to lock to incoming data. The Deserializer outputs will remain in TRI-STATE until the Deserializer detects data transmission at its inputs and locks to the incoming data stream.

TRANSMITTING DATA

Once you power up the Serializer and Deserializer, they must be phase locked to each other to transmit data. Phase locking occurs when the Deserializer locks to incoming data or when the Serializer sends patterns. The Serializer sends SYNC patterns whenever the SYNC1 or SYNC2 inputs are high. The $\overline{\text{LOCK}}$ output of the Deserializer remains high until it has locked to the incoming data stream. Connecting the $\overline{\text{LOCK}}$ output of the Deserializer to one of the SYNC inputs of the Serializer will ensure that enough SYNC patterns are sent to achieve Deserializer lock.

The Deserializer can also lock to incoming data by simply powering up the device and allowing the “random lock” circuitry to find and lock to the data stream.

While the Deserializer $\overline{\text{LOCK}}$ output is low, data at the Deserializer outputs (ROUT0-9) is valid, except for the specific case of loss of lock during transmission which is further discussed in [RECOVERING FROM LOCK LOSS](#).

NOISE MARGIN

The Deserializer noise margin is the amount of input jitter (phase noise) that the Deserializer can tolerate and still reliably receive data. Various environmental and systematic factors include:

- **Serializer:** TCLK jitter, V_{CC} noise (noise bandwidth and out-of-band noise)
- **Media:** ISI, Large V_{CM} shifts
- **Deserializer:** V_{CC} noise

RECOVERING FROM LOCK LOSS

In the case where the Deserializer loses lock during data transmission, up to 3 cycles of data that were previously received can be invalid. This is due to the delay in the lock detection circuit. The lock detect circuit requires that invalid clock information be received 4 times in a row to indicate loss of lock. Since clock information has been lost, it is possible that data was also lost during these cycles. Therefore, after the Deserializer relocks to the incoming data stream and the Deserializer LOCK pin goes low, at least three previous data cycles should be suspect for bit errors.

The Deserializer can relock to the incoming data stream by making the Serializer resend SYNC patterns, as described above, or by random locking, which can take more time, depending on the data patterns being received.

HOT INSERTION

All the BLVDS devices are hot pluggable if you follow a few rules. When inserting, ensure the Ground pin(s) makes contact first, then the VCC pin(s), and then the I/O pins. When removing, the I/O pins should be unplugged first, then the VCC, then the Ground. Random lock hot insertion is illustrated in [Figure 23](#).

PCB CONSIDERATIONS

The Bus LVDS Serializer and Deserializer should be placed as close to the edge connector as possible. In multiple Deserializer applications, the distance from the Deserializer to the slot connector appears as a stub to the Serializer driving the backplane traces. Longer stubs lower the impedance of the bus, increase the load on the Serializer, and lower the threshold margin at the Deserializers. Deserializer devices should be placed much less than one inch from slot connectors. Because transition times are very fast on the Serializer Bus LVDS outputs, reducing stub lengths as much as possible is the best method to ensure signal integrity.

TRANSMISSION MEDIA

The Serializer and Deserializer can also be used in point-to-point configuration of a backplane, through a PCB trace, or through twisted pair cable. In point-to-point configuration, the transmission media need only be terminated at the receiver end. Please note that in point-to-point configuration, the potential of offsetting the ground levels of the Serializer vs. the Deserializer must be considered. Also, Bus LVDS provides a +/- 1.2V common mode range at the receiver inputs.

FAILSAFE BIASING FOR THE SCAN921226

The SCAN921226 has an improved input threshold sensitivity of +/- 50mV versus +/- 100mV for the DS92LV1210 or DS92LV1212. This allows for greater differential noise margin in the SCAN921226. However, in cases where the receiver input is not being actively driven, the increased sensitivity of the SCAN921226 can pickup noise as a signal and cause unintentional locking. For example, this can occur when the input cable is disconnected.

External resistors can be added to the receiver circuit board to prevent noise pick-up. Typically, the non-inverting receiver input is pulled up and the inverting receiver input is pulled down by high value resistors. The pull-up and pull-down resistors (R_1 and R_2) provide a current path through the termination resistor (R_L) which biases the receiver inputs when they are not connected to an active driver. The value of the pull-up and pull-down resistors should be chosen so that enough current is drawn to provide a +15mV drop across the termination resistor. Please see [Figure 20](#) for the Failsafe Biasing Setup.

USING T_{DJIT} AND T_{RNM} TO VALIDATE SIGNAL QUALITY

The parameter t_{RNM} is calculated by first measuring how much of the ideal bit the receiver needs to ensure correct sampling. After determining this amount, what remains of the ideal bit that is available for external sources of noise is called t_{RNM} . t_{RNM} includes transmitter jitter.

Please refer to [Figure 21](#) and [Figure 22](#) for a graphic representation of t_{DJIT} and t_{RNM} . Also, for a more detailed explanation of t_{RNM} , please see the Application Note titled 'How to Validate BLVDS SER/DES Signal Integrity Using an Eye Mask' (SNLA053).

The vertical limits of the mask are determined by the SCAN921226 receiver input threshold of $\pm 50\text{mV}$.

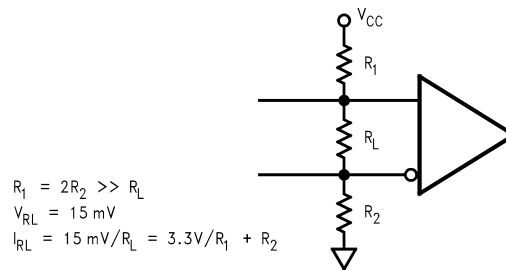

Figure 20. Failsafe Biasing Setup

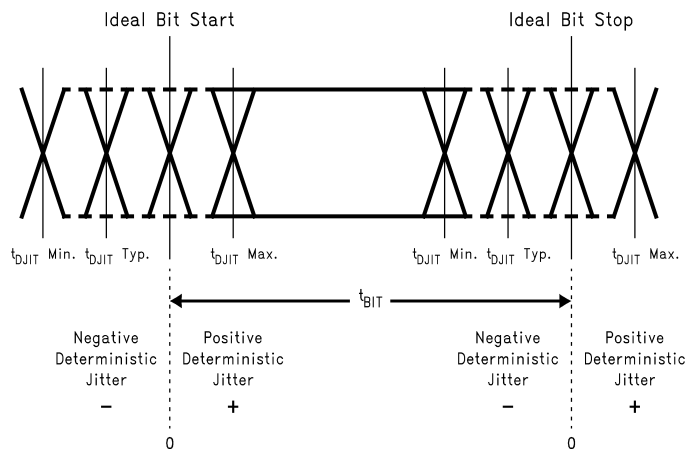
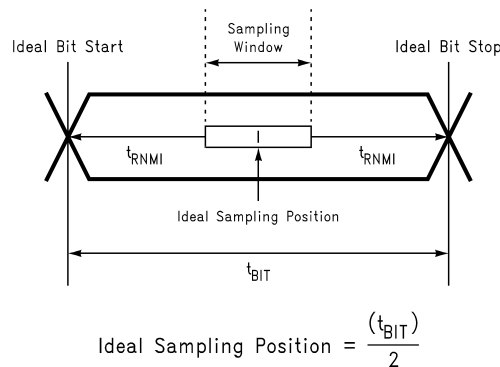

Figure 21. Deterministic Jitter and Ideal Bit Position



t_{RNM-L} is the ideal noise margin on the left of the figure, it is a negative value to indicate early with respect to ideal. t_{RNM-R} is the ideal noise margin on the right of the above figure, it is a positive value to indicate late with respect to ideal.

Figure 22. Ideal Deserializer Noise Margin (t_{RNM}) and Sampling Window

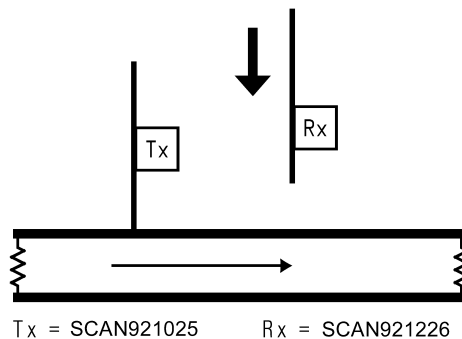

Figure 23. Random Lock Hot Insertion

PIN DIAGRAMS

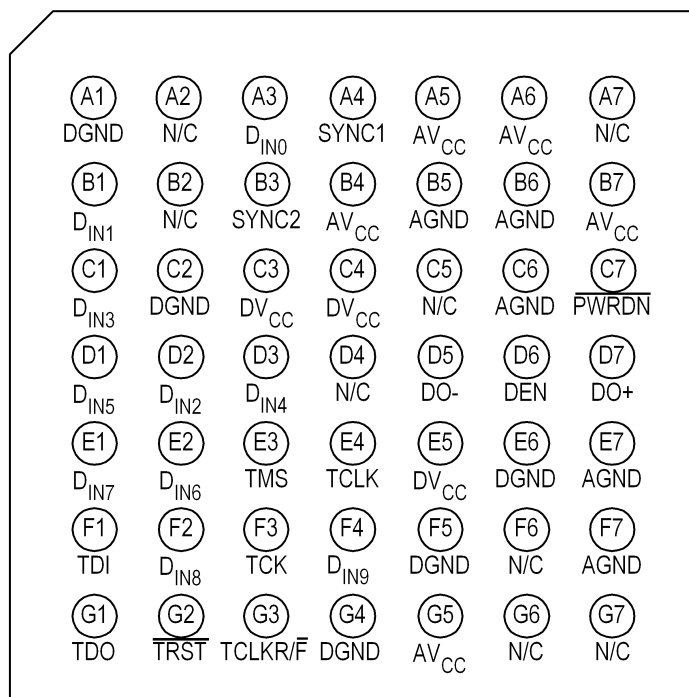

Figure 24. SCAN921025SLC - Serializer (Top View)

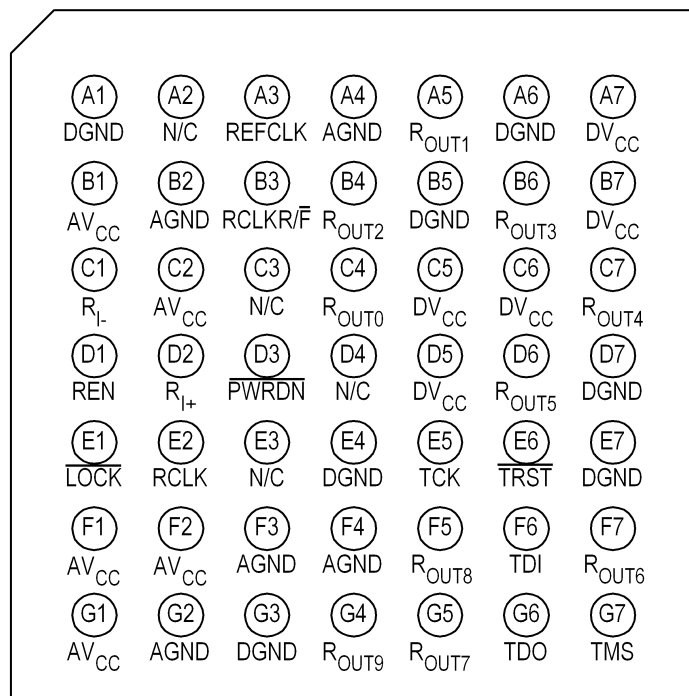

Figure 25. SCAN921226SLC - Deserializer (Top View)

SERIALIZER PIN DESCRIPTIONS

Pin Name	I/O	Ball Id.	Description
DIN	I	A3, B1, C1, D1, D2, D3, E1, E2, F2, F4	Data Input. LVTTTL levels inputs. Data on these pins are loaded into a 10-bit input register.
TCLKR/F	I	G3	Transmit Clock Rising/Falling strobe select. LVTTTL level input. Selects TCLK active edge for strobing of DIN data. High selects rising edge. Low selects falling edge.
DO+	O	D7	+ Serial Data Output. Non-inverting Bus LVDS differential output.
DO-	O	D5	- Serial Data Output. Inverting Bus LVDS differential output.
DEN	I	D6	Serial Data Output Enable. LVTTTL level input. A low puts the Bus LVDS outputs in TRI-STATE.
PWRDN	I	C7	Powerdown. LVTTTL level input. PWRDN driven low shuts down the PLL and TRI-STATE outputs putting the device into a low power sleep mode.
TCLK	I	E4	Transmit Clock. LVTTTL level input. Input for 30MHz – 80MHz system clock.
SYNC	I	A4, B3	Assertion of SYNC (high) for at least 1024 synchronization symbols to be transmitted on the Bus LVDS serial output. Synchronization symbols continue to be sent if SYNC continues to be asserted. TTL level input. The two SYNC pins are ORed.
DVCC	I	C3, C4, E5	Digital Circuit power supply.
DGND	I	A1, C2, F5, E6, G4	Digital Circuit ground.
AVCC	I	A5, A6, B4, B7, G5	Analog power supply (PLL and Analog Circuits).
AGND	I	B5, B6, C6, E7, F7	Analog ground (PLL and Analog Circuits).
TDI	I	F1	Test Data Input to support IEEE 1149.1. There is an internal pullup resistor that defaults this input to high per IEEE 1149.1.
TDO	O	G1	Test Data Output to support IEEE 1149.1

SERIALIZER PIN DESCRIPTIONS (continued)

Pin Name	I/O	Ball Id.	Description
TMS	I	E3	Test Mode Select Input to support IEEE 1149.1. There is an internal pullup resistor that defaults this input to high per IEEE 1149.1.
TCK	I	F3	Test Clock Input to support IEEE 1149.1
$\overline{\text{TRST}}$	I	G2	Test Reset Input to support IEEE 1149.1. There is an internal pullup resistor that defaults this input to high per IEEE 1149.1.
N/C	N/A	A2, A7, B2, C5, D4, F6, G6, G7	Leave open circuit, do not connect

DESERIALIZER PIN DESCRIPTIONS

Pin Name	I/O	Ball Id.	Description
ROUT	O	A5, B4, B6, C4, C7, D6, F5, F7, G4, G5	Data Output. ± 9 mA CMOS level outputs.
RCLKR/ $\overline{\text{F}}$	I	B3	Recovered Clock Rising/Falling strobe select. TTL level input. Selects RCLK active edge for strobing of ROUT data. High selects rising edge. Low selects falling edge.
RI+	I	D2	+ Serial Data Input. Non-inverting Bus LVDS differential input.
RI-	I	C1	- Serial Data Input. Inverting Bus LVDS differential input.
$\overline{\text{PWRDN}}$	I	D3	Powerdown. TTL level input. $\overline{\text{PWRDN}}$ driven low shuts down the PLL and TRI-STATEs outputs putting the device into a low power sleep mode.
$\overline{\text{LOCK}}$	O	E1	$\overline{\text{LOCK}}$ goes low when the Deserializer PLL locks onto the embedded clock edge. CMOS level output. Totem pole output structure, does not directly support wired OR connections.
RCLK	O	E2	Recovered Clock. Parallel data rate clock recovered from embedded clock. Used to strobe ROUT, CMOS level output.
REN	I	D1	Output Enable. TTL level input. When driven low, TRI-STATES ROUT0–ROUT9 and RCLK.
DVCC	I	A7, B7, C5, C6, D5	Digital Circuit power supply.
DGND	I	A1, A6, B5, D7, E4, E7, G3	Digital Circuit ground.
AVCC	I	B1, C2, F1, F2, G1	Analog power supply (PLL and Analog Circuits).
AGND	I	A4, B2, F3, F4, G2	Analog ground (PLL and Analog Circuits).
REFCLK	I	A3	Use this pin to supply a REFCLK signal for the internal PLL frequency.
TDI	I	F6	Test Data Input to support IEEE 1149.1. There is an internal pullup resistor that defaults this input to high per IEEE 1149.1.
TDO	O	G6	Test Data Output to support IEEE 1149.1
TMS	I	G7	Test Mode Select Input to support IEEE 1149.1. There is an internal pullup resistor that defaults this input to high per IEEE 1149.1.
TCK	I	E5	Test Clock Input to support IEEE 1149.1
$\overline{\text{TRST}}$	I	E6	Test Reset Input to support IEEE 1149.1. There is an internal pullup resistor that defaults this input to high per IEEE 1149.1.
N/C	N/A	A2, C3, D4, E3	Leave open circuit, do not connect

DESERIALIZER TRUTH TABLE

INPUTS		OUTPUTS		
$\overline{\text{PWRDN}}$	REN	ROUT [0:9] ⁽¹⁾	$\overline{\text{LOCK}}$ ⁽²⁾	RCLK ⁽³⁾
H ⁽⁴⁾	H	Z	H	Z
H	H	Active	L	Active
L	X	Z	Z	Z
H	L	Z	Active	Z

- (1) ROUT and RCLK are TRI-STATEd when $\overline{\text{LOCK}}$ is asserted High.
- (2) LOCK Active indicates the LOCK output will reflect the state of the Deserializer with regard to the selected data stream.
- (3) RCLK Active indicates the RCLK will be running if the Deserializer is locked. The Timing of RCLK with respect to ROUT is determined by RCLK_R/F.
- (4) During Power-up.

REVISION HISTORY

Changes from Revision B (April 2013) to Revision C	Page
<hr/> <ul style="list-style-type: none">• Changed layout of National Data Sheet to TI format	<hr/> 22

PACKAGING INFORMATION

Orderable Device	Status (1)	Package Type	Package Drawing	Pins	Package Qty	Eco Plan (2)	Lead finish/ Ball material (6)	MSL Peak Temp (3)	Op Temp (°C)	Device Marking (4/5)	Samples
SCAN921025SLC/NOPB	NRND	NFBGA	NZA	49	416	RoHS & Green	SNAGCU	Level-4-260C-72 HR		SCAN921025 SLC	
SCAN921226SLC/NOPB	NRND	NFBGA	NZA	49	416	RoHS & Green	SNAGCU	Level-4-260C-72 HR		SCAN921226 SLC	

(1) The marketing status values are defined as follows:

ACTIVE: Product device recommended for new designs.

LIFEBUY: TI has announced that the device will be discontinued, and a lifetime-buy period is in effect.

NRND: Not recommended for new designs. Device is in production to support existing customers, but TI does not recommend using this part in a new design.

PREVIEW: Device has been announced but is not in production. Samples may or may not be available.

OBSOLETE: TI has discontinued the production of the device.

(2) **RoHS:** TI defines "RoHS" to mean semiconductor products that are compliant with the current EU RoHS requirements for all 10 RoHS substances, including the requirement that RoHS substance do not exceed 0.1% by weight in homogeneous materials. Where designed to be soldered at high temperatures, "RoHS" products are suitable for use in specified lead-free processes. TI may reference these types of products as "Pb-Free".

RoHS Exempt: TI defines "RoHS Exempt" to mean products that contain lead but are compliant with EU RoHS pursuant to a specific EU RoHS exemption.

Green: TI defines "Green" to mean the content of Chlorine (Cl) and Bromine (Br) based flame retardants meet JS709B low halogen requirements of <=1000ppm threshold. Antimony trioxide based flame retardants must also meet the <=1000ppm threshold requirement.

(3) MSL, Peak Temp. - The Moisture Sensitivity Level rating according to the JEDEC industry standard classifications, and peak solder temperature.

(4) There may be additional marking, which relates to the logo, the lot trace code information, or the environmental category on the device.

(5) Multiple Device Markings will be inside parentheses. Only one Device Marking contained in parentheses and separated by a "~" will appear on a device. If a line is indented then it is a continuation of the previous line and the two combined represent the entire Device Marking for that device.

(6) Lead finish/Ball material - Orderable Devices may have multiple material finish options. Finish options are separated by a vertical ruled line. Lead finish/Ball material values may wrap to two lines if the finish value exceeds the maximum column width.

Important Information and Disclaimer: The information provided on this page represents TI's knowledge and belief as of the date that it is provided. TI bases its knowledge and belief on information provided by third parties, and makes no representation or warranty as to the accuracy of such information. Efforts are underway to better integrate information from third parties. TI has taken and continues to take reasonable steps to provide representative and accurate information but may not have conducted destructive testing or chemical analysis on incoming materials and chemicals. TI and TI suppliers consider certain information to be proprietary, and thus CAS numbers and other limited information may not be available for release.

In no event shall TI's liability arising out of such information exceed the total purchase price of the TI part(s) at issue in this document sold by TI to Customer on an annual basis.

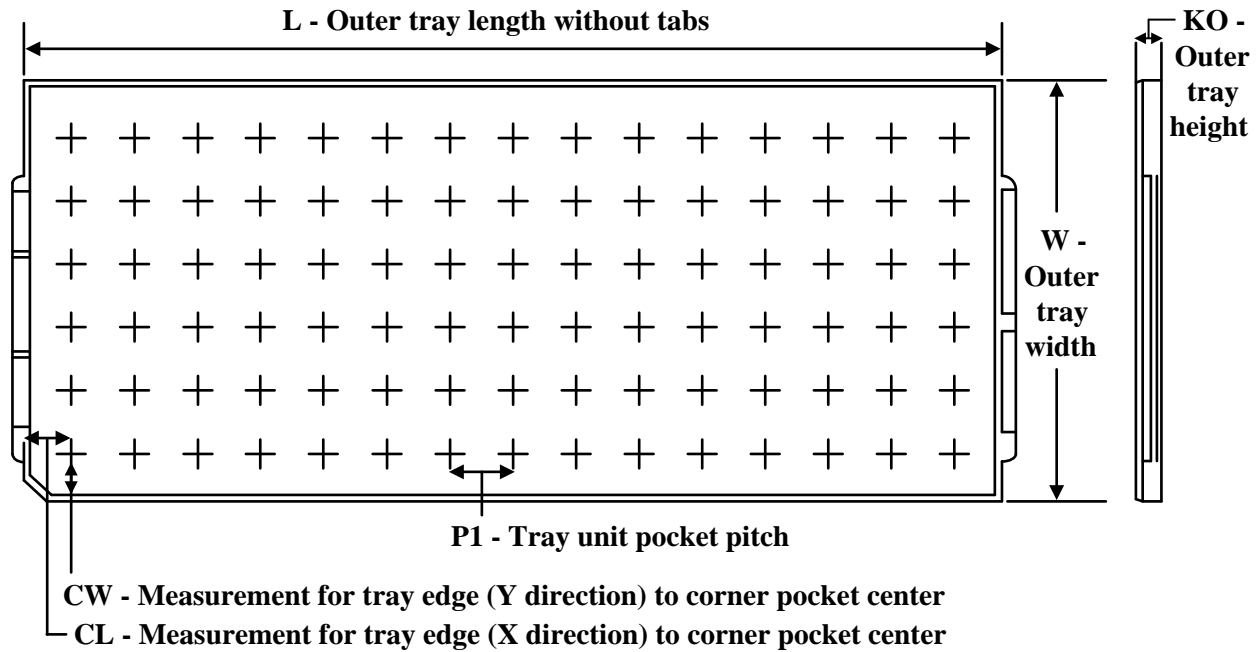
TRAY

Chamfer on Tray corner indicates Pin 1 orientation of packed units.

*All dimensions are nominal

Device	Package Name	Package Type	Pins	SPQ	Unit array matrix	Max temperature (°C)	L (mm)	W (mm)	K0 (µm)	P1 (mm)	CL (mm)	CW (mm)
SCAN921025SLC/NOPB	NZA	NFBGA	49	416	13 X 32	150	322.6	135.9	7620	9.4	11.8	11.55
SCAN921226SLC/NOPB	NZA	NFBGA	49	416	13 X 32	150	322.6	135.9	7620	9.4	11.8	11.55

NZA0049A

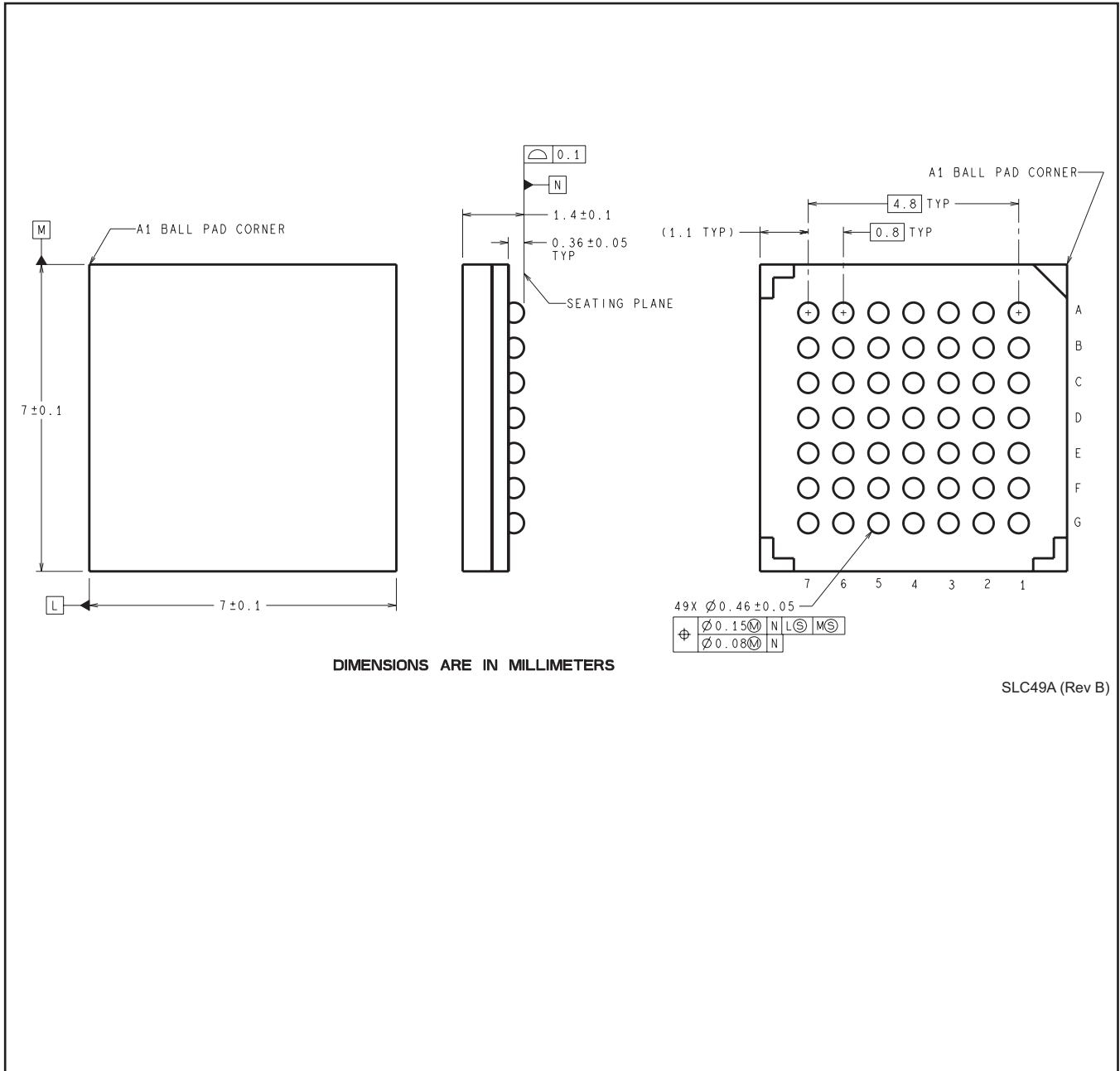

SLC49A (Rev B)

IMPORTANT NOTICE AND DISCLAIMER

TI PROVIDES TECHNICAL AND RELIABILITY DATA (INCLUDING DATA SHEETS), DESIGN RESOURCES (INCLUDING REFERENCE DESIGNS), APPLICATION OR OTHER DESIGN ADVICE, WEB TOOLS, SAFETY INFORMATION, AND OTHER RESOURCES "AS IS" AND WITH ALL FAULTS, AND DISCLAIMS ALL WARRANTIES, EXPRESS AND IMPLIED, INCLUDING WITHOUT LIMITATION ANY IMPLIED WARRANTIES OF MERCHANTABILITY, FITNESS FOR A PARTICULAR PURPOSE OR NON-INFRINGEMENT OF THIRD PARTY INTELLECTUAL PROPERTY RIGHTS.

These resources are intended for skilled developers designing with TI products. You are solely responsible for (1) selecting the appropriate TI products for your application, (2) designing, validating and testing your application, and (3) ensuring your application meets applicable standards, and any other safety, security, regulatory or other requirements.

These resources are subject to change without notice. TI grants you permission to use these resources only for development of an application that uses the TI products described in the resource. Other reproduction and display of these resources is prohibited. No license is granted to any other TI intellectual property right or to any third party intellectual property right. TI disclaims responsibility for, and you will fully indemnify TI and its representatives against, any claims, damages, costs, losses, and liabilities arising out of your use of these resources.

TI's products are provided subject to [TI's Terms of Sale](#) or other applicable terms available either on [ti.com](https://www.ti.com) or provided in conjunction with such TI products. TI's provision of these resources does not expand or otherwise alter TI's applicable warranties or warranty disclaimers for TI products.

TI objects to and rejects any additional or different terms you may have proposed.

Mailing Address: Texas Instruments, Post Office Box 655303, Dallas, Texas 75265
Copyright © 2023, Texas Instruments Incorporated

Looking for pricing, stock, or lifecycle information?

Click below to explore more details on WIN SOURCE:

 [View SCAN921226SLC/NOPB on WIN SOURCE](#)

 [Texas Instruments](#) Information

Optimize Your Supply Chain with WIN SOURCE Solutions

-  Global Sourcing Solution
-  Obsolete Management
-  Cost Control Management
-  Shortage Management
-  Alternative Solution
-  Excess Inventory Management