



**THE DATASHEET OF  
SN74AVC32T245GKER**



# SN74AVC32T245 32-Bit Dual-Supply Bus Transceiver

## With Configurable Voltage Translation, Level-Shifting, and Tri-State Outputs

### 1 Features

- Member of the Texas Instruments Widebus+™ Family
- Control Inputs  $V_{IH}/V_{IL}$  Levels Referenced to  $V_{CCA}$  Voltage
- $V_{CC}$  Isolation Feature – If Either  $V_{CC}$  Input is at GND, Both Ports are in the High-Impedance State
- Overvoltage-Tolerant Inputs/Outputs Allow Mixed-Voltage-Mode Data Communications
- Fully Configurable Dual-Rail Design Allows Each Port to Operate Over Full 1.2 V to 3.6 V Power-Supply Range
- $I_{off}$  Supports Partial-Power-Down Mode Operation
- 4.6 V Tolerant I/Os
- Max Data Rates
  - 380 Mbps (1.8 V to 3.3 V Level-Shifting)
  - 200 Mbps (< 1.8 V to 3.3 V Level-Shifting)
  - 200 Mbps (Translate to 2.5 V or 1.8 V)
  - 150 Mbps (Translate to 1.5 V)
  - 100 Mbps (Translate to 1.2 V)
- Latch-Up Performance Exceeds 100 mA Per JESD 78, Class II
- ESD Protection Exceeds JESD 22
  - 4000 V Human-Body Model (A114-A)
  - 1000 V Charged-Device Model (C101)

### 2 Applications

- Personal Electronics
- Industrial
- Enterprise
- Telecom

### 3 Description

This 32-bit noninverting bus transceiver uses two separate, configurable power-supply rails. The SN74AVC32T245 device is optimized to operate with  $V_{CCA}/V_{CCB}$  set from 1.4 V to 3.6 V. It is operational with  $V_{CCA}/V_{CCB}$  as low as 1.2 V. The A port is designed to track  $V_{CCA}$ .  $V_{CCA}$  and accepts any supply voltage from 1.2 V to 3.6 V. The B port is designed to track  $V_{CCB}$ .  $V_{CCB}$  and accepts any supply voltage from 1.2 V to 3.6 V. This allows for universal low-voltage bidirectional translation between any of the 1.2 V, 1.5 V, 1.8 V, 2.5 V, and 3.3 V voltage nodes.

The SN74AVC32T245 is designed for asynchronous communication between data buses. The device transmits data from the A bus to the B bus or from the B bus to the A bus, depending on the logic level at the direction-control (DIR) input. The output-enable ( $\overline{OE}$ ) input can disable the outputs so the buses are effectively isolated.

The SN74AVC32T245 is designed so that the control pins (1DIR, 2DIR, 3DIR, 4DIR, 1 $\overline{OE}$ , 2 $\overline{OE}$ , 3 $\overline{OE}$ , and 4 $\overline{OE}$ ) are supplied by  $V_{CCA}$ .

#### Device Information

PART NUMBER	PACKAGE <sup>(1)</sup>	BODY SIZE (NOM)
SN74AVC32T245ZKE/ GKE	LFBGA (96)	13.50 mm × 5.50 mm
SN74AVC32T245ZRL	BGA MICROSTAR JUNIOR (96)	8.50 mm × 3.50 mm
SN74AVC32T245NMJ	nFBGA (96)	13.50 mm × 5.50 mm

- (1) For all available packages, see the orderable addendum at the end of the data sheet.

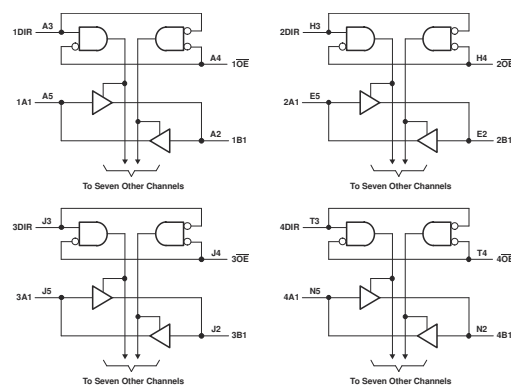


Figure 3-1. Logic Diagram



## Table of Contents

<b>1 Features</b> .....	1	9.1 Overview.....	17
<b>2 Applications</b> .....	1	9.2 Functional Block Diagram.....	17
<b>3 Description</b> .....	1	9.3 Feature Description.....	18
<b>4 Revision History</b> .....	2	9.4 Device Functional Modes.....	18
<b>5 Description (continued)</b> .....	3	<b>10 Application and Implementation</b> .....	19
<b>6 Pin Configuration and Functions</b> .....	4	10.1 Application Information.....	19
<b>7 Specifications</b> .....	8	10.2 EnableTimes.....	19
7.1 Absolute Maximum Ratings.....	8	10.3 Typical Application.....	20
7.2 ESD Ratings.....	8	<b>11 Power Supply Recommendations</b> .....	22
7.3 Thermal Information.....	8	<b>12 Layout</b> .....	22
7.4 Recommended Operating Conditions.....	9	12.1 Layout Guidelines.....	22
7.5 Electrical Characteristics.....	10	12.2 Layout Example.....	22
7.6 Switching Characteristics: $V_{CCA} = 1.2\text{ V}$ .....	11	<b>13 Device and Documentation Support</b> .....	23
7.7 Switching Characteristics: $V_{CCA} = 1.5\text{ V} \pm 0.1\text{ V}$ .....	11	13.1 Documentation Support.....	23
7.8 Switching Characteristics: $V_{CCA} = 1.8\text{ V} \pm 0.15\text{ V}$ .....	12	13.2 Receiving Notification of Documentation Updates.....	23
7.9 Switching Characteristics: $V_{CCA} = 2.5\text{ V} \pm 0.2\text{ V}$ .....	12	13.3 Support Resources.....	23
7.10 Switching Characteristics: $V_{CCA} = 3.3\text{ V} \pm 0.3\text{ V}$ .....	13	13.4 Trademarks.....	23
7.11 Operating Characteristics.....	13	13.5 Electrostatic Discharge Caution.....	23
7.12 Typical Characteristics.....	14	13.6 Glossary.....	23
<b>8 Parameter Measurement Information</b> .....	16	<b>14 Mechanical, Packaging, and Orderable Information</b> .....	23
<b>9 Detailed Description</b> .....	17		

## 4 Revision History

NOTE: Page numbers for previous revisions may differ from page numbers in the current version.

Changes from Revision G (July 2020) to Revision H (November 2020)	Page
• Updated the numbering format for tables, figures, and cross-references throughout the document.....	1
• Changed SN74AVC32T245NMJ nFBGA (96) body size from 8.50 mm × 3.50 mm to 13.50 mm × 5.50 mm in the <i>Device Information</i> table.....	1

Changes from Revision F (July 2015) to Revision G (July 2020)	Page
• Added NMJ package option to <i>Device Information</i> table.....	1
• Added NMJ package pinout drawing.....	4
• Added NMJ package option to <i>Thermal Information</i> table.....	8

Changes from Revision E (August 2007) to Revision F (July 2015)	Page
• Added <i>Pin Configuration and Functions</i> section, <i>ESD Ratings</i> table, <i>Feature Description</i> section, <i>Device Functional Modes</i> , <i>Application and Implementation</i> section, <i>Power Supply Recommendations</i> section, <i>Layout</i> section, <i>Device and Documentation Support</i> section, and <i>Mechanical, Packaging, and Orderable Information</i> section.....	1

## 5 Description (continued)

This device is fully specified for partial-power-down applications using  $I_{off}$ . The  $I_{off}$  circuitry disables the outputs, preventing damaging current backflow through the device when it is powered down.

The  $V_{CC}$  isolation feature ensures that if either  $V_{CC}$  input is at GND, then both ports are in the high-impedance state.

To ensure the high-impedance state during power up or power down,  $\overline{OE}$  should be tied to  $V_{CC}$  through a pullup resistor; the minimum value of the resistor is determined by the current-sinking capability of the driver.

## 6 Pin Configuration and Functions

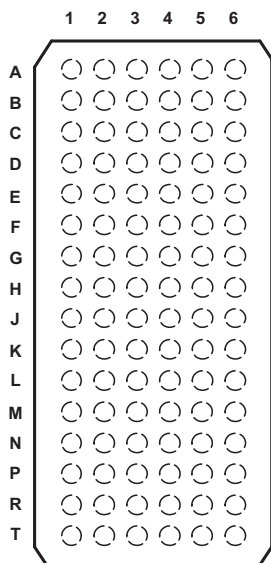


Figure 6-1. GKE, ZKE Package 96-Pin LFBGA Top View

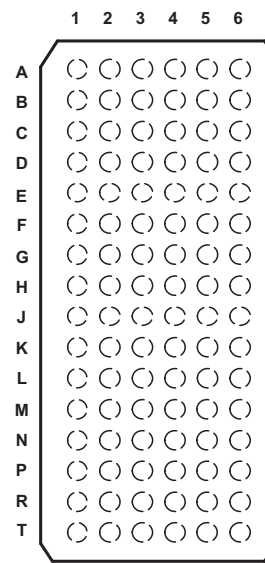


Figure 6-2. ZRL Package 96-Pin BGA MICROSTAR JUNIOR Top View

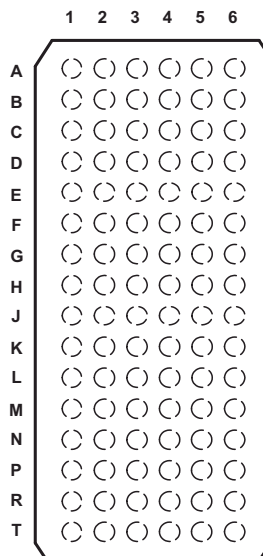


Figure 6-3. NMJ Package 96-Pin nFBGA Top View

Table 6-1. Pin Assignments

	1	2	3	4	5	6
<b>A</b>	1B2	1B1	1DIR	1 $\overline{OE}$	1A1	1A2
<b>B</b>	1B4	1B3	GND	GND	1A3	1A4
<b>C</b>	1B6	1B5	V <sub>CCB</sub>	V <sub>CCA</sub>	1A5	1A6
<b>D</b>	1B8	1B7	GND	GND	1A7	1A8
<b>E</b>	2B2	2B1	GND	GND	2A1	2A2
<b>F</b>	2B4	2B3	V <sub>CCB</sub>	V <sub>CCA</sub>	2A3	2A4
<b>G</b>	2B6	2B5	GND	GND	2A5	2A6
<b>H</b>	2B7	2B8	2DIR	2 $\overline{OE}$	2A8	2A7
<b>J</b>	3B2	3B1	3DIR	3 $\overline{OE}$	3A1	3A2

**Table 6-1. Pin Assignments (continued)**

	1	2	3	4	5	6
<b>K</b>	3B4	3B3	GND	GND	3A3	3A4
<b>L</b>	3B6	3B5	V <sub>CCB</sub>	V <sub>CCA</sub>	3A5	3A6
<b>M</b>	3B8	3B7	GND	GND	3A7	3A8
<b>N</b>	4B2	4B1	GND	GND	4A1	4A2
<b>P</b>	4B4	4B3	V <sub>CCB</sub>	V <sub>CCA</sub>	4A3	4A4
<b>R</b>	4B6	4B5	GND	GND	4A5	4A6
<b>T</b>	4B7	4B8	4DIR	4 $\overline{OE}$	4A8	4A7

**Table 6-2. Pin Functions**

PIN		I/O	DESCRIPTION
NO.	NAME		
A1	1B2	Input/Output	Referenced to V <sub>CCB</sub>
A2	1B1	Input/Output	Referenced to V <sub>CCB</sub>
A3	1DIR	Input	Direction-control signal
A4	1 $\overline{OE}$	Input	Tri-State output-mode enables. Pull $\overline{OE}$ high to place all outputs in Tri-State mode. Referenced to V <sub>CCA</sub>
A5	1A1	Input/Output	Referenced to V <sub>CCA</sub>
A6	1A2	Input/Output	Referenced to V <sub>CCA</sub>
B1	1B4	Input/Output	Referenced to V <sub>CCB</sub>
B2	1B3	Input/Output	Referenced to V <sub>CCB</sub>
B3	GND	—	Ground
B4	GND	—	Ground
B5	1A3	Input/Output	Referenced to V <sub>CCA</sub>
B6	1A4	Input/Output	Referenced to V <sub>CCA</sub>
C1	1B6	Input/Output	Referenced to V <sub>CCB</sub>
C2	1B5	Input/Output	Referenced to V <sub>CCB</sub>
C3	V <sub>CCB</sub>	—	B-port supply voltage. $1.2\text{ V} \leq V_{CCB} \leq 3.6\text{ V}$
C4	V <sub>CCA</sub>	—	A-port supply voltage. $1.2\text{ V} \leq V_{CCA} \leq 3.6\text{ V}$
C5	1A5	Input/Output	Referenced to V <sub>CCA</sub>
C6	1A6	Input/Output	Referenced to V <sub>CCA</sub>
D1	1B8	Input/Output	Referenced to V <sub>CCB</sub>
D2	1B7	Input/Output	Referenced to V <sub>CCB</sub>
D3	GND	—	Ground
D4	GND	—	Ground
D5	1A7	Input/Output	Referenced to V <sub>CCA</sub>
D6	1A8	Input/Output	Referenced to V <sub>CCA</sub>
E1	2B2	Input/Output	Referenced to V <sub>CCB</sub>
E2	2B1	Input/Output	Referenced to V <sub>CCB</sub>
E3	GND	—	Ground
E4	GND	—	Ground
E5	2A1	Input/Output	Referenced to V <sub>CCA</sub>
E6	2A2	Input/Output	Referenced to V <sub>CCA</sub>
F1	2B4	Input/Output	Referenced to V <sub>CCB</sub>
F2	2B3	Input/Output	Referenced to V <sub>CCB</sub>
F3	V <sub>CCB</sub>	—	B-port supply voltage. $1.2\text{ V} \leq V_{CCB} \leq 3.6\text{ V}$
F4	V <sub>CCA</sub>	—	A-port supply voltage. $1.2\text{ V} \leq V_{CCA} \leq 3.6\text{ V}$

**Table 6-2. Pin Functions (continued)**

PIN		I/O	DESCRIPTION
NO.	NAME		
F5	2A3	Input/Output	Referenced to $V_{CCA}$
F6	2A4	Input/Output	Referenced to $V_{CCA}$
G1	2B6	Input/Output	Referenced to $V_{CCB}$
G2	2B5	Input/Output	Referenced to $V_{CCB}$
G3	GND	—	Ground
G4	GND	—	Ground
G5	2A5	Input/Output	Referenced to $V_{CCA}$
G6	2A6	Input/Output	Referenced to $V_{CCA}$
H1	2B7	Input/Output	Referenced to $V_{CCB}$
H2	2B8	Input/Output	Referenced to $V_{CCB}$
H3	2DIR	Input	Direction-control signal
H4	2 $\overline{OE}$	Input	Tri-State output-mode enables. Pull $\overline{OE}$ high to place all outputs in Tri-State mode. Referenced to $V_{CCA}$
H5	2A8	Input/Output	Referenced to $V_{CCA}$
H6	2A7	Input/Output	Referenced to $V_{CCA}$
J1	3B2	Input/Output	Referenced to $V_{CCB}$
J2	3B1	Input/Output	Referenced to $V_{CCB}$
J3	3DIR	Input	Direction-control signal
J4	3 $\overline{OE}$	Input	Tri-State output-mode enables. Pull $\overline{OE}$ high to place all outputs in Tri-State mode. Referenced to $V_{CCA}$
J5	3A1	Input/Output	Referenced to $V_{CCA}$
J6	3A2	Input/Output	Referenced to $V_{CCA}$
K1	3B4	Input/Output	Referenced to $V_{CCB}$
K2	3B3	Input/Output	Referenced to $V_{CCB}$
K3	GND	—	Ground
K4	GND	—	Ground
K5	3A3	Input/Output	Referenced to $V_{CCA}$
K6	3A4	Input/Output	Referenced to $V_{CCA}$
L1	3B6	Input/Output	Referenced to $V_{CCB}$
L2	3B5	Input/Output	Referenced to $V_{CCB}$
L3	$V_{CCB}$	—	B-port supply voltage. $1.2\text{ V} \leq V_{CCB} \leq 3.6\text{ V}$
L4	$V_{CCA}$	—	A-port supply voltage. $1.2\text{ V} \leq V_{CCA} \leq 3.6\text{ V}$
L5	3A5	Input/Output	Referenced to $V_{CCA}$
L6	3A6	Input/Output	Referenced to $V_{CCA}$
M1	3B8	Input/Output	Referenced to $V_{CCB}$
M2	3B7	Input/Output	Referenced to $V_{CCB}$
M3	GND	—	Ground
M4	GND	—	Ground
M5	3A7	Input/Output	Referenced to $V_{CCA}$
M6	3A8	Input/Output	Referenced to $V_{CCA}$
N1	4B2	Input/Output	Referenced to $V_{CCB}$
N2	4B1	Input/Output	Referenced to $V_{CCB}$
N3	GND	—	Ground
N4	GND	—	Ground
N5	4A1	Input/Output	Referenced to $V_{CCA}$

**Table 6-2. Pin Functions (continued)**

PIN		I/O	DESCRIPTION
NO.	NAME		
N6	4A2	Input/Output	Referenced to $V_{CCA}$
P1	4B4	Input/Output	Referenced to $V_{CCB}$
P2	4B3	Input/Output	Referenced to $V_{CCB}$
P3	$V_{CCB}$	—	A-port supply voltage. $1.2\text{ V} \leq V_{CCB} \leq 3.6\text{ V}$
P4	$V_{CCA}$	—	A-port supply voltage. $1.2\text{ V} \leq V_{CCA} \leq 3.6\text{ V}$
P5	4A3	Input/Output	Referenced to $V_{CCA}$
P6	4A4	Input/Output	Referenced to $V_{CCA}$
R1	4B6	Input/Output	Referenced to $V_{CCB}$
R2	4B5	Input/Output	Referenced to $V_{CCB}$
R3	GND	—	Ground
R4	GND	—	Ground
R5	4A5	Input/Output	Referenced to $V_{CCA}$
R6	4A6	Input/Output	Referenced to $V_{CCA}$
T1	4B7	Input/Output	Referenced to $V_{CCB}$
T2	4B8	Input/Output	Referenced to $V_{CCB}$
T3	4DIR	Input	Direction-control signal
T4	4 $\overline{OE}$	Input	Tri-State output-mode enables. Pull $\overline{OE}$ high to place all outputs in Tri-State mode. Referenced to $V_{CCA}$
T5	4A8	Input/Output	Referenced to $V_{CCA}$
T6	4A7	Input/Output	Referenced to $V_{CCA}$

## 7 Specifications

### 7.1 Absolute Maximum Ratings

over operating free-air temperature range (unless otherwise noted)<sup>(1)</sup>

		MIN	MAX	UNIT	
$V_{CCA}$ $V_{CCB}$	Supply voltage	-0.5	4.6	V	
$V_I$	Input voltage <sup>(2)</sup>	I/O ports (A port)	-0.5	4.6	V
		I/O ports (B port)	-0.5	4.6	
		Control inputs	-0.5	4.6	
$V_O$	Voltage applied to any output in the high-impedance or power-off state <sup>(2)</sup>	A port	-0.5	4.6	V
		B port	-0.5	4.6	
$V_O$	Voltage range applied to any output in the high or low state <sup>(2) (3)</sup>	A port	-0.5	$V_{CCA} + 0.5$	V
		B port	-0.5	$V_{CCB} + 0.5$	
$I_{IK}$	Input clamp current	$V_I < 0$	-50	mA	
$I_{OK}$	Output clamp current	$V_O < 0$	-50	mA	
$I_O$	Continuous output current		±50	mA	
	Continuous current through each $V_{CCA}$ , $V_{CCB}$ , and GND		±100	mA	
$T_{stg}$	Storage temperature	-65	150	°C	

- (1) Stresses beyond those listed under *Absolute Maximum Ratings* may cause permanent damage to the device. These are stress ratings only, and functional operation of the device at these or any other conditions beyond those indicated under *Recommended Operating Conditions* is not implied. Exposure to absolute-maximum-rated conditions for extended periods may affect device reliability.
- (2) The input voltage and output negative-voltage ratings may be exceeded if the input and output current ratings are observed.
- (3) The output positive-voltage rating may be exceeded up to 4.6 V maximum if the output current rating is observed.

### 7.2 ESD Ratings

		VALUE	UNIT
$V_{(ESD)}$	Electrostatic discharge	Human body model (HBM), per ANSI/ESDA/JEDEC JS-001 <sup>(1)</sup>	±8000
		Charged-device model (CDM), per JEDEC specification JESD22-C101 <sup>(2)</sup>	±1000

- (1) JEDEC document JEP155 states that 500V HBM allows safe manufacturing with a standard ESD control process.
- (2) JEDEC document JEP157 states that 250V CDM allows safe manufacturing with a standard ESD control process.

### 7.3 Thermal Information

THERMAL METRIC <sup>(1)</sup>	SN74AVC32T245			UNIT	
	GKE/ZKE (LFBGA)	ZRL (MICROSTAR JUNIOR)	NMJ (nFBGA)		
	96 PINS	96 PINS	96 PINS		
$R_{\theta JA}$	Junction-to-ambient thermal resistance	70.7	105.8	26.7	°C/W
$R_{\theta JC(top)}$	Junction-to-case (top) thermal resistance	34.0	1.6	14.4	°C/W
$R_{\theta JB}$	Junction-to-board thermal resistance	43.5	10.8	10.7	°C/W
$\psi_{JT}$	Junction-to-top characterization parameter	3.5	3.1	1.3	°C/W
$\psi_{JB}$	Junction-to-board characterization parameter	43.5	10.8	10.5	°C/W

- (1) For more information about traditional and new thermal metrics, see the *Semiconductor and IC Package Thermal Metrics* application report, [SPRA953](#).

## 7.4 Recommended Operating Conditions

See (1) (2) (3)

		$V_{CCI}$	$V_{CCO}$	MIN	MAX	UNIT
$V_{CCA}$	Supply voltage			1.2	3.6	V
$V_{CCB}$	Supply voltage			1.2	3.6	V
$V_{IH}$	High-level input voltage	Data inputs <sup>(4)</sup>	1.2 V to 1.95 V	$V_{CCI} \times 0.65$		V
			1.95 V to 2.7 V	1.6		
			2.7 V to 3.6 V	2		
$V_{IL}$	Low-level input voltage	Data inputs <sup>(4)</sup>	1.2 V to 1.95 V	$V_{CCI} \times 0.35$		V
			1.95 V to 2.7 V	0.7		
			2.7 V to 3.6 V	0.8		
$V_{IH}$	High-level input voltage	DIR (referenced to $V_{CCA}$ ) <sup>(5)</sup>	1.2 V to 1.95 V	$V_{CCA} \times 0.65$		V
			1.95 V to 2.7 V	1.6		
			2.7 V to 3.6 V	2		
$V_{IL}$	Low-level input voltage	DIR (referenced to $V_{CCA}$ ) <sup>(5)</sup>	1.2 V to 1.95 V	$V_{CCA} \times 0.35$		V
			1.95 V to 2.7 V	0.7		
			2.7 V to 3.6 V	0.8		
$V_I$	Input voltage			0	3.6	V
$V_O$	Output voltage	Active state		0	$V_{CCO}$	V
		3-state		0	3.6	
$I_{OH}$	High-level output current		1.2 V	-3		mA
			1.4 V to 1.6 V	-6		
			1.65 V to 1.95 V	-8		
			2.3 V to 2.7 V	-9		
			3 V to 3.6 V	-12		
$I_{OL}$	Low-level output current		1.2 V	3		mA
			1.4 V to 1.6 V	6		
			1.65 V to 1.95 V	8		
			2.3 V to 2.7 V	9		
			3 V to 3.6 V	12		
$\Delta t/\Delta v$	Input transition rise or fall rate				5	ns/V
$T_A$	Operating free-air temperature			-40	85	°C

- (1)  $V_{CCI}$  is the  $V_{CC}$  associated with the data input port.
- (2)  $V_{CCO}$  is the  $V_{CC}$  associated with the output port.
- (3) All unused data inputs of the device must be held at  $V_{CCI}$  or GND to ensure proper device operation. Refer to the TI application report, *Implications of Slow or Floating CMOS Inputs*, literature number SCBA004.
- (4) For  $V_{CCI}$  values not specified in the data sheet,  $V_{IH}$  min =  $V_{CCI} \times 0.7$  V,  $V_{IL}$  max =  $V_{CCI} \times 0.3$  V.
- (5) For  $V_{CCI}$  values not specified in the data sheet,  $V_{IH}$  min =  $V_{CCA} \times 0.7$  V,  $V_{IL}$  max =  $V_{CCA} \times 0.3$  V.

## 7.5 Electrical Characteristics

over recommended operating free-air temperature range (unless otherwise noted)<sup>(2) (3)</sup>

PARAMETER	TEST CONDITIONS	V <sub>CCA</sub>	V <sub>CCB</sub>	T <sub>A</sub> = 25°C			–40°C TO 85°C		UNIT
				MIN	TYP	MAX	MIN	MAX	
V <sub>OH</sub>	I <sub>OH</sub> = –100 μA	V <sub>I</sub> = V <sub>IH</sub>	1.2 V to 3.6 V	1.2 V to 3.6 V			V <sub>CCO</sub> – 0.2 V		V
	I <sub>OH</sub> = –3 mA		1.2 V	1.2 V	0.95				
	I <sub>OH</sub> = –6 mA		1.4 V	1.4 V			1.05		
	I <sub>OH</sub> = –8 mA		1.65 V	1.65 V			1.2		
	I <sub>OH</sub> = –9 mA		2.3 V	2.3 V			1.75		
	I <sub>OH</sub> = –12 mA		3 V	3 V			2.3		
V <sub>OL</sub>	I <sub>OL</sub> = 100 μA	V <sub>I</sub> = V <sub>IL</sub>	1.2 V to 3.6 V	1.2 V to 3.6 V			0.2		V
	I <sub>OL</sub> = 3 mA		1.2 V	1.2 V	0.15				
	I <sub>OL</sub> = 6 mA		1.4 V	1.4 V			0.35		
	I <sub>OL</sub> = 8 mA		1.65 V	1.65 V			0.45		
	I <sub>OL</sub> = 9 mA		2.3 V	2.3 V			0.55		
	I <sub>OL</sub> = 12 mA		3 V	3 V			0.7		
I <sub>I</sub>	Control inputs	V <sub>I</sub> = V <sub>CCA</sub> or GND	1.2 V to 3.6 V	1.2 V to 3.6 V	±0.025	±0.25	±1		μA
I <sub>off</sub>	A or B port	V <sub>I</sub> or V <sub>O</sub> = 0 to 3.6 V	0 V	0 to 3.6 V	±0.1	±2.5	±5		μA
	A or B port		0 to 3.6 V	0 V	±0.1	±2.5	±5		
I <sub>OZ</sub> <sup>(1)</sup>	A or B port	V <sub>O</sub> = V <sub>CCO</sub> or GND, V <sub>I</sub> = V <sub>CCI</sub> or GND, OE = V <sub>IH</sub>	3.6 V	3.6 V	±0.5	±2.5	±5		μA
I <sub>CCA</sub>	V <sub>I</sub> = V <sub>CCI</sub> or GND, I <sub>O</sub> = 0	1.2 V to 3.6 V	1.2 V to 3.6 V			50		μA	
		0 V	3.6 V			–10			
		3.6 V	0 V			50			
I <sub>CCB</sub>	V <sub>I</sub> = V <sub>CCI</sub> or GND, I <sub>O</sub> = 0	1.2 V to 3.6 V	1.2 V to 3.6 V			50		μA	
		0 V	3.6 V			50			
		3.6 V	0 V			–10			
I <sub>CCA</sub> + I <sub>CCB</sub>	V <sub>I</sub> = V <sub>CCI</sub> or GND, I <sub>O</sub> = 0	1.2 V to 3.6 V	1.2 V to 3.6 V			90		μA	
C <sub>i</sub>	Control inputs	V <sub>I</sub> = 3.3 V or GND	3.3 V	3.3 V	3.5				pF
C <sub>io</sub>	A or B port	V <sub>O</sub> = 3.3 V or GND	3.3 V	3.3 V	7				pF

(1) For I/O ports, the parameter I<sub>OZ</sub> includes the input leakage current.

(2) V<sub>CCO</sub> is the V<sub>CC</sub> associated with the output port.

(3) V<sub>CCI</sub> is the V<sub>CC</sub> associated with the input port.

## 7.6 Switching Characteristics: $V_{CCA} = 1.2\text{ V}$

over recommended operating free-air temperature range,  $V_{CCA} = 1.2\text{ V}$  (see [Figure 8-1](#))

PARAMETER	FROM (INPUT)	TO (OUTPUT)	$V_{CCB} = 1.2\text{ V}$	$V_{CCB} = 1.5\text{ V}$	$V_{CCB} = 1.8\text{ V}$	$V_{CCB} = 2.5\text{ V}$	$V_{CCB} = 3.3\text{ V}$	UNIT
			TYP	TYP	TYP	TYP	TYP	
$t_{PLH}$	A	B	4.1	3.3	3	2.8	3.2	ns
$t_{PHL}$			4.1	3.3	3	2.8	3.2	
$t_{PLH}$	B	A	4.4	4	3.8	3.6	3.5	ns
$t_{PHL}$			4.4	4	3.8	3.6	3.5	
$t_{PZH}$	$\overline{OE}$	A	6.4	6.4	6.4	6.4	6.4	ns
$t_{PZL}$			6.4	6.4	6.4	6.4	6.4	
$t_{PZH}$	$\overline{OE}$	B	6	4.6	4	3.4	3.2	ns
$t_{PZL}$			6	4.6	4	3.4	3.2	
$t_{PHZ}$	$\overline{OE}$	A	6.6	6.6	6.6	6.6	6.8	ns
$t_{PLZ}$			6.6	6.6	6.6	6.6	6.8	
$t_{PHZ}$	$\overline{OE}$	B	6	4.9	4.9	4.2	5.3	ns
$t_{PLZ}$			6	4.9	4.9	4.2	5.3	

## 7.7 Switching Characteristics: $V_{CCA} = 1.5\text{ V} \pm 0.1\text{ V}$

over recommended operating free-air temperature range,  $V_{CCA} = 1.5\text{ V} \pm 0.1\text{ V}$  (see [Figure 8-1](#))

PARAMETER	FROM (INPUT)	TO (OUTPUT)	$V_{CCB} = 1.2\text{ V}$	$V_{CCB} = 1.5\text{ V} \pm 0.1\text{ V}$		$V_{CCB} = 1.8\text{ V} \pm 0.15\text{ V}$		$V_{CCB} = 2.5\text{ V} \pm 0.2\text{ V}$		$V_{CCB} = 3.3\text{ V} \pm 0.3\text{ V}$		UNIT
			TYP	MIN	MAX	MIN	MAX	MIN	MAX	MIN	MAX	
$t_{PLH}$	A	B	3.6	0.5	6.2	0.5	5.2	0.5	4.1	0.5	3.7	ns
$t_{PHL}$			3.6	0.5	6.2	0.5	5.2	0.5	4.1	0.5	3.7	
$t_{PLH}$	B	A	3.3	0.5	6.2	0.5	5.9	0.5	5.6	0.5	5.5	ns
$t_{PHL}$			3.3	0.5	6.2	0.5	5.9	0.5	5.6	0.5	5.5	
$t_{PZH}$	$\overline{OE}$	A	4.3	1	10.1	1	10.1	1	10.1	1	10.1	ns
$t_{PZL}$			4.3	1	10.1	1	10.1	1	10.1	1	10.1	
$t_{PZH}$	$\overline{OE}$	B	5.6	1	10.1	0.5	8.1	0.5	5.9	0.5	5.2	ns
$t_{PZL}$			5.6	1	10.1	0.5	8.1	0.5	5.9	0.5	5.2	
$t_{PHZ}$	$\overline{OE}$	A	4.5	1.5	9.1	1.5	9.1	1.5	9.1	1.5	9.1	ns
$t_{PLZ}$			4.5	1.5	9.1	1.5	9.1	1.5	9.1	1.5	9.1	
$t_{PHZ}$	$\overline{OE}$	B	5.5	1.5	8.7	1.5	7.5	1	6.5	1	6.3	ns
$t_{PLZ}$			5.5	1.5	8.7	1.5	7.5	1	6.5	1	6.3	

### 7.8 Switching Characteristics: $V_{CCA} = 1.8 \text{ V} \pm 0.15 \text{ V}$

over recommended operating free-air temperature range,  $V_{CCA} = 1.8 \text{ V} \pm 0.15 \text{ V}$  (see [Figure 8-1](#))

PARAMETER	FROM (INPUT)	TO (OUTPUT)	$V_{CCB} = 1.2 \text{ V}$	$V_{CCB} = 1.5 \text{ V} \pm 0.1 \text{ V}$		$V_{CCB} = 1.8 \text{ V} \pm 0.15 \text{ V}$		$V_{CCB} = 2.5 \text{ V} \pm 0.2 \text{ V}$		$V_{CCB} = 3.3 \text{ V} \pm 0.3 \text{ V}$		UNIT
			TYP	MIN	MAX	MIN	MAX	MIN	MAX	MIN	MAX	
$t_{PLH}$	A	B	3.4	0.5	5.9	0.5	4.8	0.5	3.7	0.5	3.3	ns
$t_{PHL}$			3.4	0.5	5.9	0.5	4.8	0.5	3.7	0.5	3.3	
$t_{PLH}$	B	A	3	0.5	5.2	0.5	4.8	0.5	4.5	0.5	4.4	ns
$t_{PHL}$			3	0.5	5.2	0.5	4.8	0.5	4.5	0.5	4.4	
$t_{PZH}$	$\overline{OE}$	A	3.4	1	7.8	1	7.8	1	7.8	1	7.8	ns
$t_{PZL}$			3.4	1	7.8	1	7.8	1	7.8	1	7.8	
$t_{PZH}$	$\overline{OE}$	B	5.4	1	9.2	0.5	7.4	0.5	5.3	0.5	4.5	ns
$t_{PZL}$			5.4	1	9.2	0.5	7.4	0.5	5.3	0.5	4.5	
$t_{PHZ}$	$\overline{OE}$	A	4.2	1.5	7.7	1.5	7.7	1.5	7.7	1.5	7.7	ns
$t_{PLZ}$			4.2	1.5	7.7	1.5	7.7	1.5	7.7	1.5	7.7	
$t_{PHZ}$	$\overline{OE}$	B	5.2	1.5	8.4	1.5	7.1	1	5.9	1	5.7	ns
$t_{PLZ}$			5.2	1.5	8.4	1.5	7.1	1	5.9	1	5.7	

### 7.9 Switching Characteristics: $V_{CCA} = 2.5 \text{ V} \pm 0.2 \text{ V}$

over recommended operating free-air temperature range,  $V_{CCA} = 2.5 \text{ V} \pm 0.2 \text{ V}$  (see [Figure 8-1](#))

PARAMETER	FROM (INPUT)	TO (OUTPUT)	$V_{CCB} = 1.2 \text{ V}$	$V_{CCB} = 1.5 \text{ V} \pm 0.1 \text{ V}$		$V_{CCB} = 1.8 \text{ V} \pm 0.15 \text{ V}$		$V_{CCB} = 2.5 \text{ V} \pm 0.2 \text{ V}$		$V_{CCB} = 3.3 \text{ V} \pm 0.3 \text{ V}$		UNIT
			TYP	MIN	MAX	MIN	MAX	MIN	MAX	MIN	MAX	
$t_{PLH}$	A	B	3.2	0.5	5.6	0.5	4.5	0.5	3.3	0.5	2.8	ns
$t_{PHL}$			3.2	0.5	5.6	0.5	4.5	0.5	3.3	0.5	2.8	
$t_{PLH}$	B	A	2.6	0.5	4.1	0.5	3.7	0.5	3.3	0.5	3.2	ns
$t_{PHL}$			2.6	0.5	4.1	0.5	3.7	0.5	3.3	0.5	3.2	
$t_{PZH}$	$\overline{OE}$	A	2.5	0.5	5.3	0.5	5.3	0.5	5.3	0.5	5.3	ns
$t_{PZL}$			2.5	0.5	5.3	0.5	5.3	0.5	5.3	0.5	5.3	
$t_{PZH}$	$\overline{OE}$	B	5.2	0.5	9.4	0.5	7.3	0.5	5.1	0.5	4.5	ns
$t_{PZL}$			5.2	0.5	9.4	0.5	7.3	0.5	5.1	0.5	4.5	
$t_{PHZ}$	$\overline{OE}$	A	3	1	6.1	1	6.1	1	6.1	1	6.1	ns
$t_{PLZ}$			3	1	6.1	1	6.1	1	6.1	1	6.1	
$t_{PHZ}$	$\overline{OE}$	B	5	1	7.9	1	6.6	1	6.1	1	5.2	ns
$t_{PLZ}$			5	1	7.9	1	6.6	1	6.1	1	5.2	

### 7.10 Switching Characteristics: $V_{CCA} = 3.3\text{ V} \pm 0.3\text{ V}$

over recommended operating free-air temperature range,  $V_{CCA} = 3.3\text{ V} \pm 0.3\text{ V}$  (see [Figure 8-1](#))

PARAMETER	FROM (INPUT)	TO (OUTPUT)	$V_{CCB} = 1.2\text{ V}$	$V_{CCB} = 1.5\text{ V} \pm 0.1\text{ V}$		$V_{CCB} = 1.8\text{ V} \pm 0.15\text{ V}$		$V_{CCB} = 2.5\text{ V} \pm 0.2\text{ V}$		$V_{CCB} = 3.3\text{ V} \pm 0.3\text{ V}$		UNIT
			TYP	MIN	MAX	MIN	MAX	MIN	MAX	MIN	MAX	
$t_{PLH}$	A	B	3.2	0.5	5.5	0.5	4.4	0.5	3.2	0.5	2.7	ns
$t_{PHL}$			3.2	0.5	5.5	0.5	4.4	0.5	3.2	0.5	2.7	
$t_{PLH}$	B	A	2.8	0.5	3.7	0.5	3.3	0.5	2.8	0.5	2.7	ns
$t_{PHL}$			2.8	0.5	3.7	0.5	3.3	0.5	2.8	0.5	2.7	
$t_{PZH}$	$\overline{OE}$	A	2.2	0.5	4.3	0.5	4.2	0.5	4.1	0.5	4	ns
$t_{PZL}$			2.2	0.5	4.3	0.5	4.2	0.5	4.1	0.5	4	
$t_{PZH}$	$\overline{OE}$	B	5.1	0.5	9.3	0.5	7.2	0.5	4.9	0.5	4	ns
$t_{PZL}$			5.1	0.5	9.3	0.5	7.2	0.5	4.9	0.5	4	
$t_{PHZ}$	$\overline{OE}$	A	3.4	0.5	5	0.5	5	0.5	5	0.5	5	ns
$t_{PLZ}$			3.4	0.5	5	0.5	5	0.5	5	0.5	5	
$t_{PHZ}$	$\overline{OE}$	B	4.9	1	7.7	1	6.5	1	5.2	0.5	5	ns
$t_{PLZ}$			4.9	1	7.7	1	6.5	1	5.2	0.5	5	

### 7.11 Operating Characteristics

$T_A = 25^\circ\text{C}$

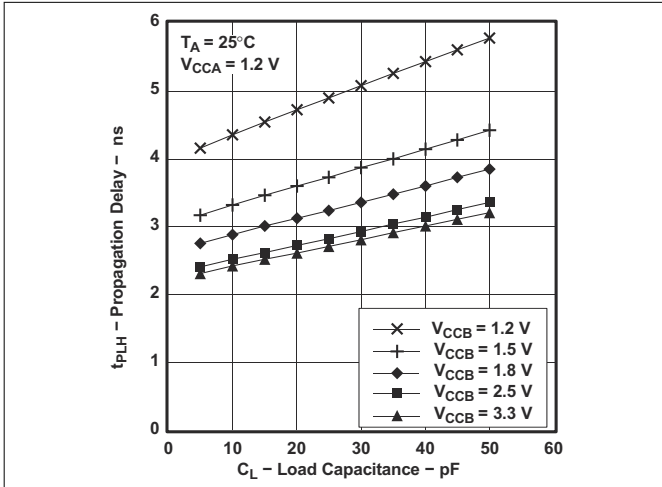
PARAMETER			TEST CONDITIONS	$V_{CCA} = V_{CCB} = 1.2\text{ V}$	$V_{CCA} = V_{CCB} = 1.5\text{ V}$	$V_{CCA} = V_{CCB} = 1.8\text{ V}$	$V_{CCA} = V_{CCB} = 2.5\text{ V}$	$V_{CCA} = V_{CCB} = 3.3\text{ V}$	UNIT
				TYP	TYP	TYP	TYP	TYP	
$C_{pdA}$ (1)	A to B	Outputs enabled	$C_L = 0,$ $f = 10\text{ MHz},$ $t_r = t_f = 1\text{ ns}$	1	1	1	1	2	pF
		Outputs disabled		1	1	1	1	1	
	B to A	Outputs enabled		13	13	14	15	16	
		Outputs disabled		1	1	1	1	1	
$C_{pdB}$ (1)	A to B	Outputs enabled	$C_L = 0,$ $f = 10\text{ MHz},$ $t_r = t_f = 1\text{ ns}$	13	13	14	15	16	pF
		Outputs disabled		1	1	1	1	1	
	B to A	Outputs enabled		1	1	1	1	2	
		Outputs disabled		1	1	1	1	1	

(1) Power dissipation capacitance per transceiver. Refer to the TI application report, CMOS Power Consumption and  $C_{pd}$  Calculation [SCAA035](#).

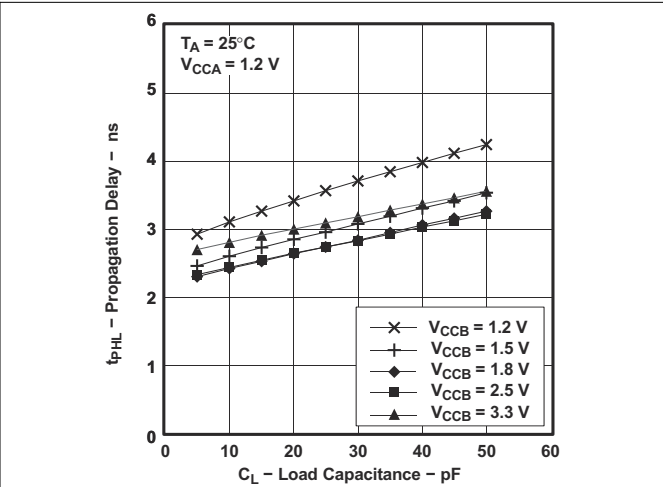
**Table 7-1. Typical Total Static Power Consumption ( $I_{CCA} + I_{CCB}$ )**

$V_{CCB}$	$V_{CCA}$						UNIT
	0 V	1.2 V	1.5 V	1.8 V	2.5 V	3.3 V	
0 V	0	<1	<1	<1	<1	<1	μA
1.2 V	<1	<2	<2	<2	<2	2	
1.5 V	<1	<2	<2	<2	<2	2	
1.8 V	<1	<2	<2	<2	<2	<2	
2.5 V	<1	2	<2	<2	<2	<2	
3.3 V	<1	2	<2	<2	<2	<2	

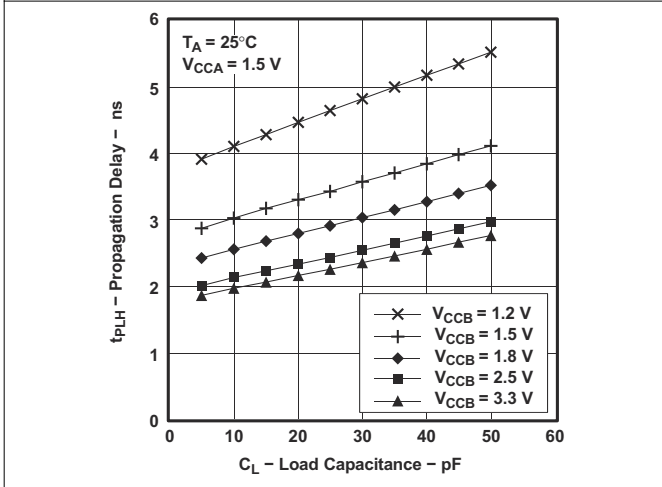
**7.12 Typical Characteristics**



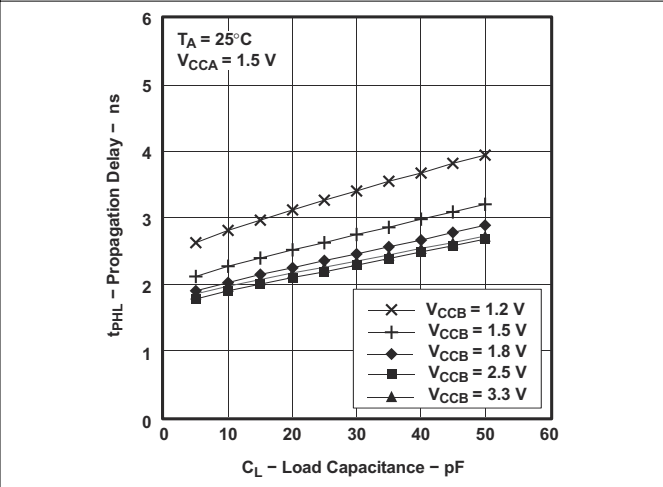
**Figure 7-1. Propagation Delay vs Load Capacitance**



**Figure 7-2. Propagation Delay vs Load Capacitance**

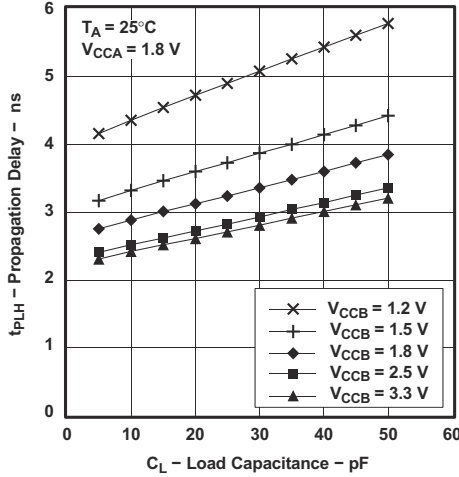


**Figure 7-3. Typical Propagation Delay  $t_{PLH}$  (A to B) vs Load Capacitance**

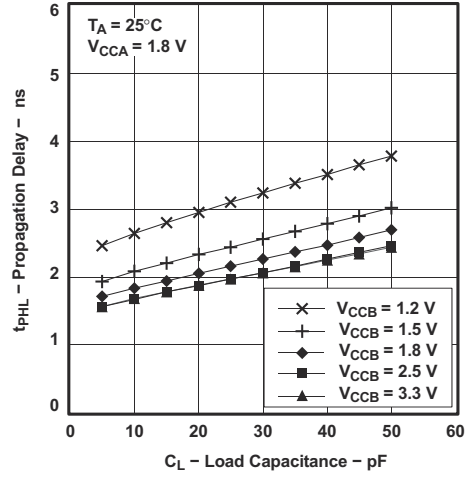


**Figure 7-4. Typical Propagation Delay  $t_{PHL}$  (A to B) vs Load Capacitance**

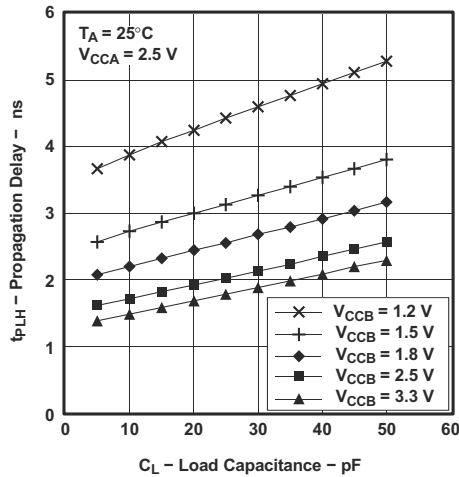
### 7.12 Typical Characteristics (continued)



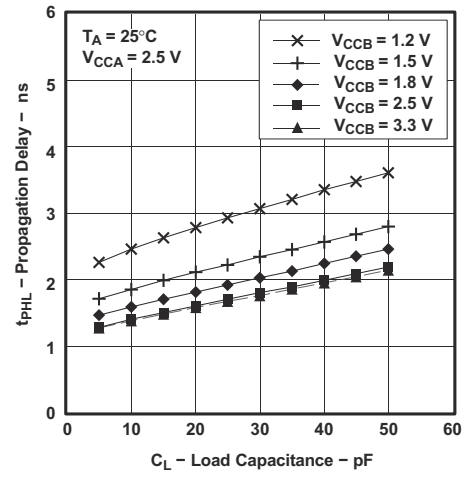
**Figure 7-5. Typical Propagation Delay  $t_{PLH}$  (A to B) vs Load Capacitance**



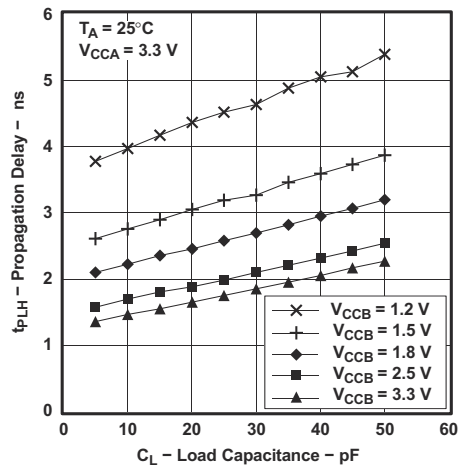
**Figure 7-6. Typical Propagation Delay  $t_{PHL}$  (A to B) vs Load Capacitance**



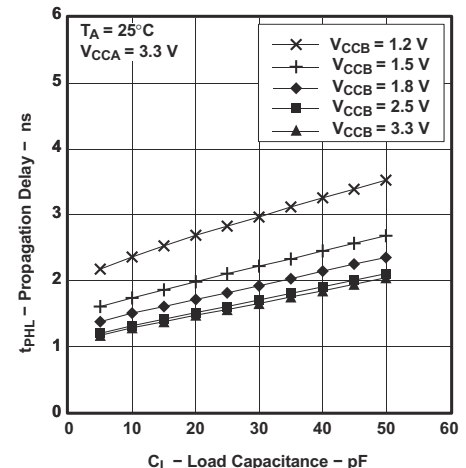
**Figure 7-7. Typical Propagation Delay  $t_{PLH}$  (A to B) vs Load Capacitance**



**Figure 7-8. Typical Propagation Delay  $t_{PHL}$  (A to B) vs Load Capacitance**

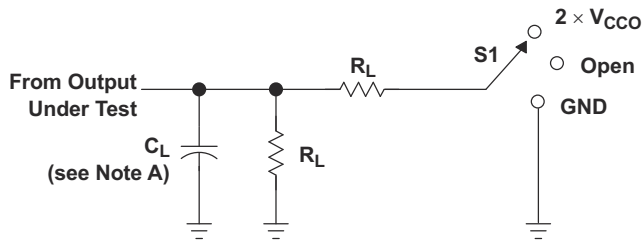


**Figure 7-9. Typical Propagation Delay  $t_{PLH}$  (A to B) vs Load Capacitance**



**Figure 7-10. Propagation Delay vs Load Capacitance**

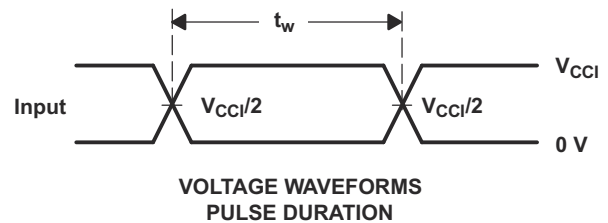
## 8 Parameter Measurement Information



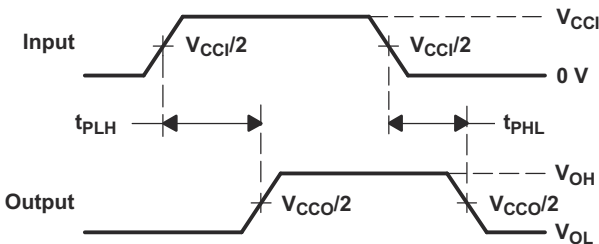
LOAD CIRCUIT

$V_{CCO}$	$C_L$	$R_L$	$V_{TP}$
1.2 V	15 pF	2 k $\Omega$	0.1 V
1.5 V $\pm$ 0.1 V	15 pF	2 k $\Omega$	0.1 V
1.8 V $\pm$ 0.15 V	15 pF	2 k $\Omega$	0.15 V
2.5 V $\pm$ 0.2 V	15 pF	2 k $\Omega$	0.15 V
3.3 V $\pm$ 0.3 V	15 pF	2 k $\Omega$	0.3 V

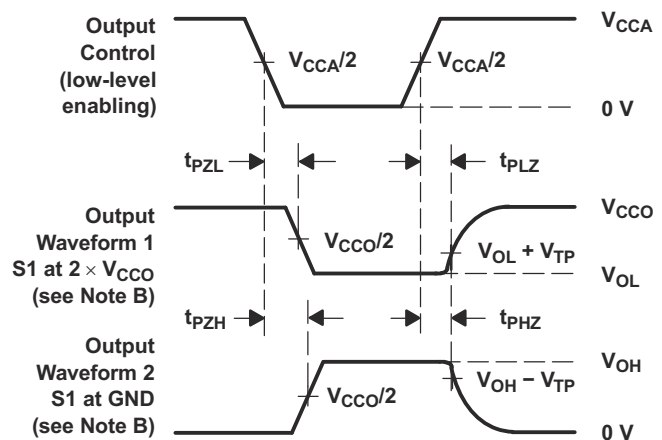
TEST	S1
$t_{pd}$	Open
$t_{PLZ}/t_{PZL}$	$2 \times V_{CCO}$
$t_{PHZ}/t_{PZH}$	GND



VOLTAGE WAVEFORMS PULSE DURATION



VOLTAGE WAVEFORMS PROPAGATION DELAY TIMES



VOLTAGE WAVEFORMS ENABLE AND DISABLE TIMES

- NOTES:
- A.  $C_L$  includes probe and jig capacitance.
  - B. Waveform 1 is for an output with internal conditions such that the output is low except when disabled by the output control. Waveform 2 is for an output with internal conditions such that the output is high, except when disabled by the output control.
  - C. All input pulses are supplied by generators having the following characteristics:  $PRR \leq 10$  MHz,  $Z_O = 50 \Omega$ ,  $dv/dt \geq 1$  V/ns.
  - D. The outputs are measured one at a time, with one transition per measurement.
  - E.  $t_{PLZ}$  and  $t_{PHZ}$  are the same as  $t_{dis}$ .
  - F.  $t_{PZL}$  and  $t_{PZH}$  are the same as  $t_{en}$ .
  - G.  $t_{PLH}$  and  $t_{PHL}$  are the same as  $t_{pd}$ .
  - H.  $V_{CC1}$  is the  $V_{CC}$  associated with the input port.
  - I.  $V_{CCO}$  is the  $V_{CC}$  associated with the output port.

Figure 8-1. Load Circuit and Voltage Waveforms

## 9 Detailed Description

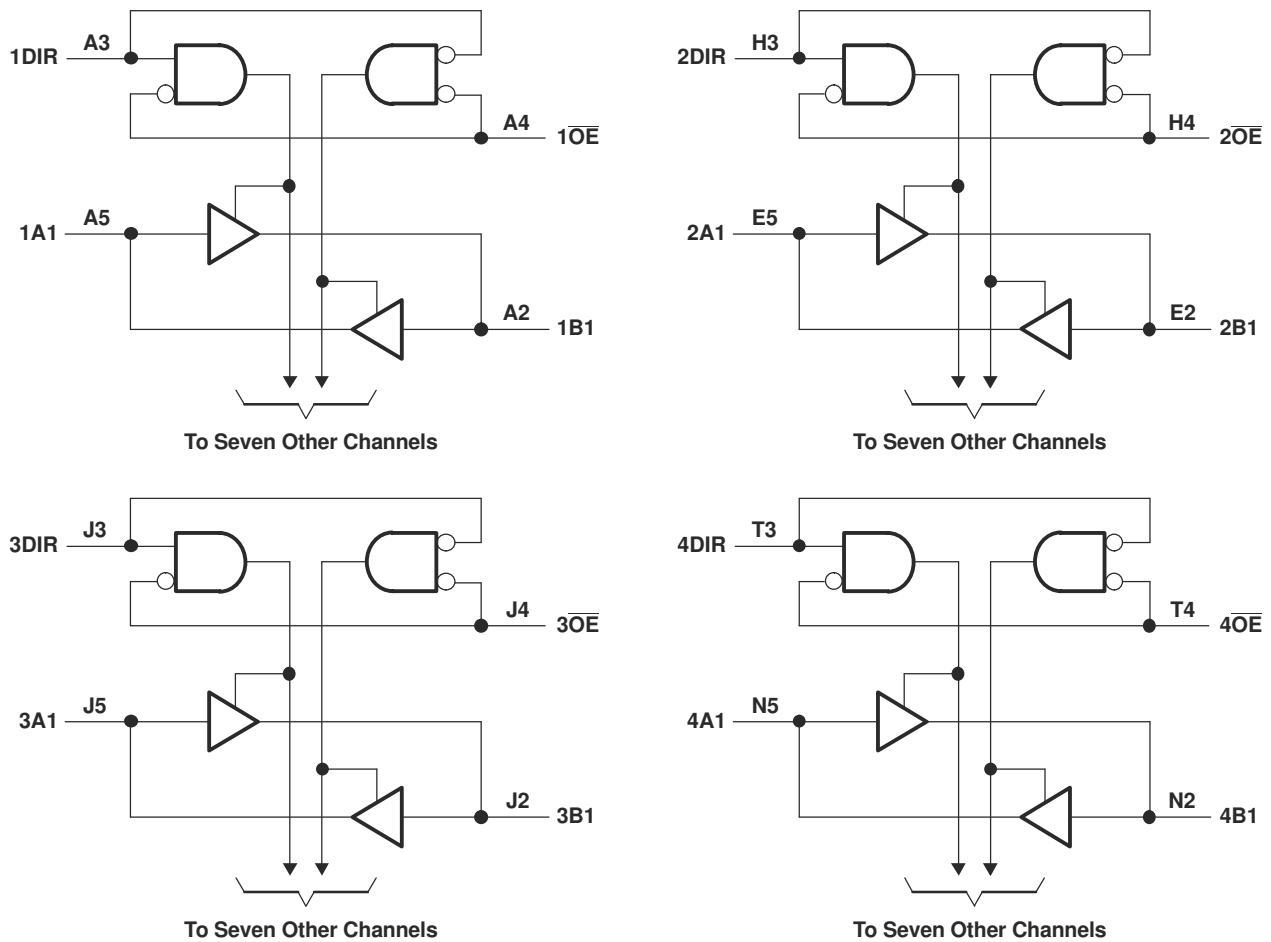
### 9.1 Overview

The SN74AVC32T245 is a 32-bit, dual-supply noninverting bidirectional voltage level translator. Pins A and control pins (DIR and  $\overline{OE}$ ) are supported by  $V_{CCA}$  and pins B are supported by  $V_{CCB}$ . The A port can accept I/O voltages ranging from 1.2 V to 3.6 V, while the B port can accept I/O voltages from 1.2 V to 3.6 V. A high on DIR allows data transmission from A to B and a low on DIR allows data transmission from B to A when  $\overline{OE}$  is set to low. When  $\overline{OE}$  is set to high, both A and B are in the high-impedance state.

This device is fully specified for partial-power-down applications using off output current ( $I_{off}$ ).

The  $V_{CC}$  isolation feature ensures that if either  $V_{CC}$  input is at GND, both ports are put in a high-impedance state.

### 9.2 Functional Block Diagram



Logic diagram (positive logic)

## 9.3 Feature Description

### 9.3.1 Fully Configurable Dual-Rail Design Allows Each Port to Operate Over the Full 1.2-V to 3.6-V Power-Supply Range

Both  $V_{CCA}$  and  $V_{CCB}$  can be supplied at any voltage from 1.2 V to 3.6 V which makes the device suitable for translating between any of the low voltage nodes (1.2 V, 1.8 V, 2.5 V, and 3.3 V).

### 9.3.2 Partial-Power-Down Mode Operation

This device is fully specified for partial-power-down applications using off output current ( $I_{off}$ ). The  $I_{off}$  circuitry will prevent backflow current by disabling I/O output circuits when device is in partial power-down mode.

### 9.3.3 $V_{CC}$ Isolation

The  $V_{CC}$  isolation feature ensures that if either  $V_{CCA}$  or  $V_{CCB}$  are at GND, both ports will be in a high-impedance state ( $I_{OZ}$ ). This prevents false logic levels from being presented to either bus.

## 9.4 Device Functional Modes

The SN74AVC32T245 is a voltage level translator that can operate from 1.2 V to 3.6 V ( $V_{CCA}$ ) and 1.2 V to 3.6 V ( $V_{CCB}$ ). The signal translation between 1.2 V and 3.6 V requires direction control and output enable control. When  $\overline{OE}$  is low and DIR is high, data transmission is from A to B. When  $\overline{OE}$  is low and DIR is low, data transmission is from B to A. When  $\overline{OE}$  is high, both output ports will be high-impedance.

**Table 9-1. Function Table  
(Each 8-Bit Section)**

INPUTS		OPERATION
$\overline{OE}$	DIR	
L	L	B data to A bus
L	H	A data to B bus
H	X	Isolation

## 10 Application and Implementation

---

### Note

Information in the following applications sections is not part of the TI component specification, and TI does not warrant its accuracy or completeness. TI's customers are responsible for determining suitability of components for their purposes. Customers should validate and test their design implementation to confirm system functionality.

---

### 10.1 Application Information

The SN74AVC32T245 device can be used in level-shifting applications for interfacing devices and addressing mixed voltage incompatibility. The SN74AVC32T245 device is ideal for data transmission where direction is different for each channel.

### 10.2 EnableTimes

Calculate the enable times for the SN74AVC32T245 using the following formulas:

$$t_{PZH} \text{ (DIR to A)} = t_{PLZ} \text{ (DIR to B)} + t_{PLH} \text{ (B to A)} \quad (1)$$

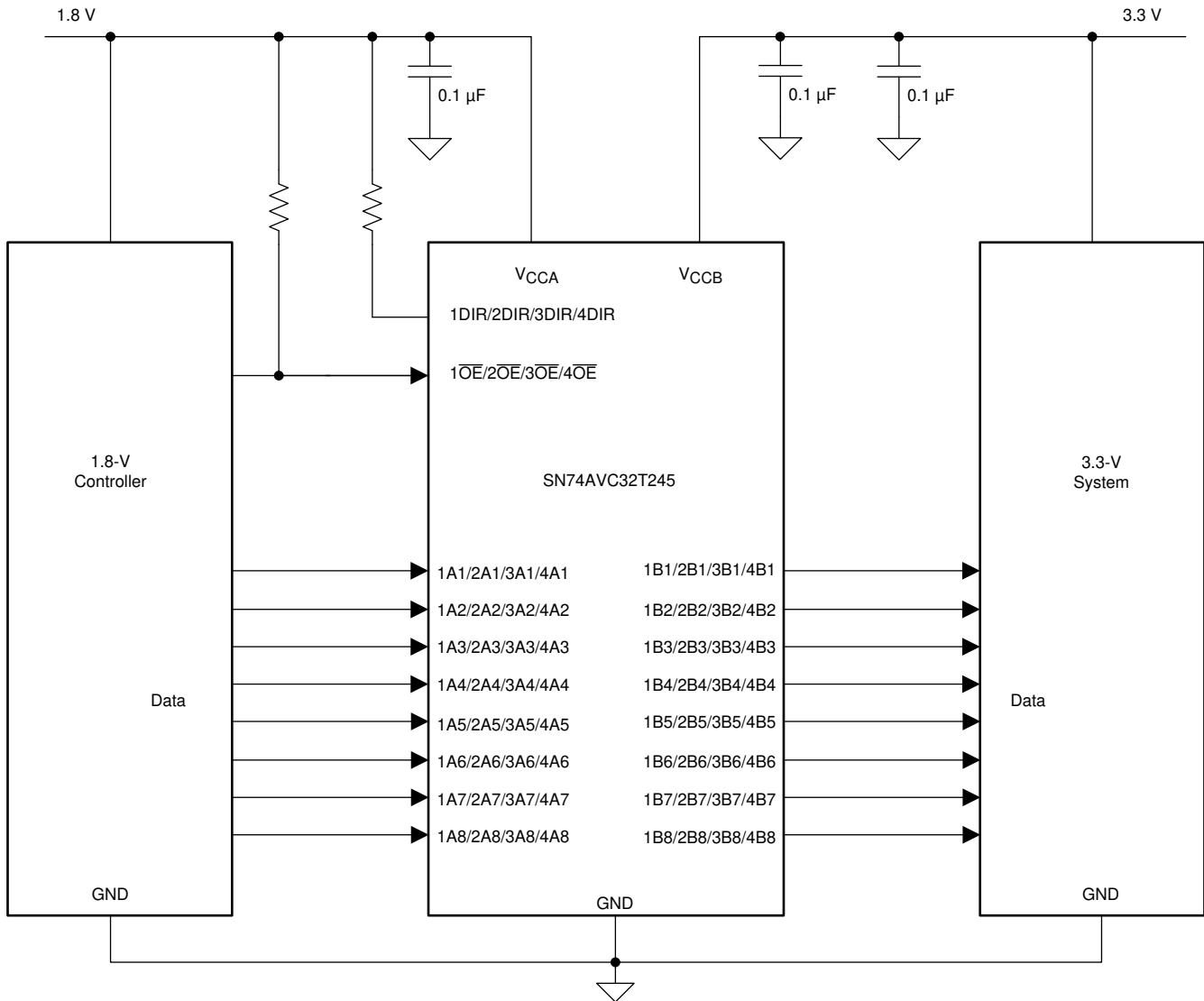
$$t_{PZL} \text{ (DIR to A)} = t_{PHZ} \text{ (DIR to B)} + t_{PHL} \text{ (B to A)} \quad (2)$$

$$t_{PZH} \text{ (DIR to B)} = t_{PLZ} \text{ (DIR to A)} + t_{PLH} \text{ (A to B)} \quad (3)$$

$$t_{PZL} \text{ (DIR to B)} = t_{PHZ} \text{ (DIR to A)} + t_{PHL} \text{ (A to B)} \quad (4)$$

In a bidirectional application, these enable times provide the maximum delay from the time the DIR bit is switched until an output is expected. For example, if the SN74AVC32T245 initially is transmitting from A to B, then the DIR bit is switched; the B port of the device must be disabled before presenting it with an input. After the B port has been disabled, an input signal applied to it appears on the corresponding A port after the specified propagation delay.

### 10.3 Typical Application



**Figure 10-1. Application Schematic**

#### 10.3.1 Design Requirements

This device uses drivers which are enabled depending on the state of the DIR pin. The designer must know the intended flow of data and take care not to violate any of the high or low logic levels. Unused data inputs must not be floating, as this can cause excessive internal leakage on the input CMOS structure. Tie any unused input and output ports directly to ground.

For this design example, use the parameters listed in the *Electrical Characteristics*.

**Table 10-1. Design Parameters**

DESIGN PARAMETER	EXAMPLE VALUE
Input voltage range	1.2 V to 3.6 V
Output voltage range	1.2 V to 3.6 V

### 10.3.2 Detailed Design Procedure

See [Section 10.3.2.1](#) and [Section 10.3.2.2](#) for information about how to begin the design process.

#### 10.3.2.1 Input Voltage Ranges

Use the supply voltage of the device that is driving the SN74AVC32T245 device to determine the input voltage range. For a valid logic high the value must exceed the  $V_{IH}$  of the input port. For a valid logic low the value must be less than the  $V_{IL}$  of the input port.

#### 10.3.2.2 Output Voltage Range

Use the supply voltage of the device that the SN74AVC32T245 device is driving to determine the output voltage range.

### 10.3.3 Application Curve

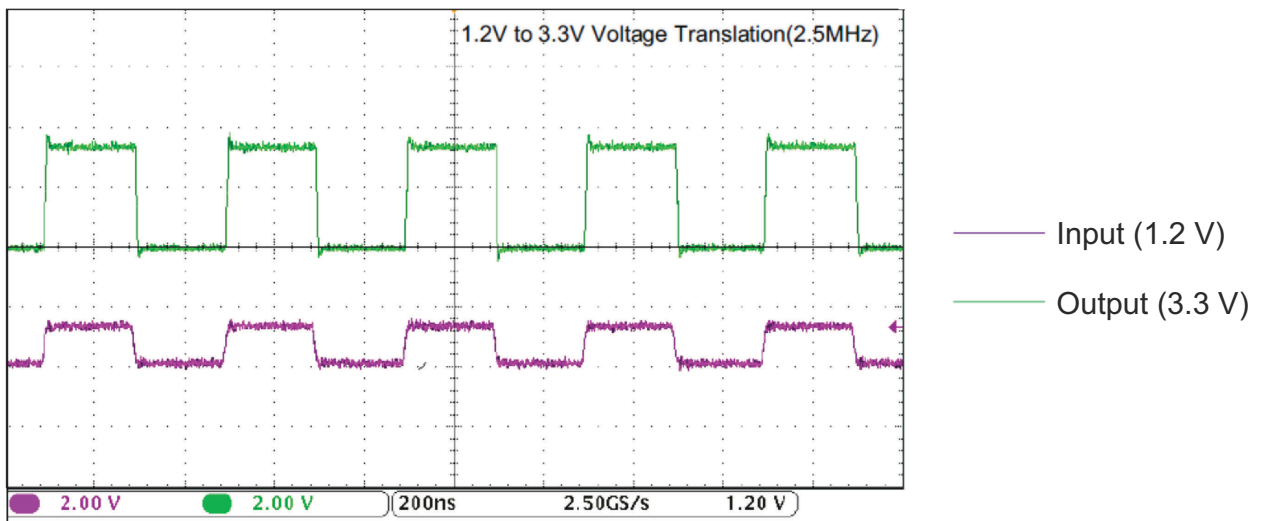


Figure 10-2. Translation Up (1.2 V to 3.3 V) at 2.5 MHz

## 11 Power Supply Recommendations

The SN74AVC32T245 device uses two separate configurable power-supply rails,  $V_{CCA}$  and  $V_{CCB}$ .  $V_{CCA}$  accepts any supply voltage from 1.2 V to 3.6 V and  $V_{CCB}$  accepts any supply voltage from 1.2 V to 3.6 V. The A port and B port are designed to track  $V_{CCA}$  and  $V_{CCB}$ , respectively, allowing for low-voltage bidirectional translation between any of the 1.2 V, 1.5 V, 1.8 V, 2.5 V and 3.3 V voltage nodes.

The output-enable  $\overline{OE}$  input circuit is designed so that it is supplied by  $V_{CCA}$  and when the  $\overline{OE}$  input is high, all outputs are placed in the high-impedance state. To ensure the high-impedance state of the outputs during power up or power down, the  $\overline{OE}$  input pin must be tied to  $V_{CCA}$  through a pullup resistor and must not be enabled until  $V_{CCA}$  and  $V_{CCB}$  are fully ramped and stable. The minimum value of the pullup resistor to  $V_{CCA}$  is determined by the current-sinking capability of the driver.

## 12 Layout

### 12.1 Layout Guidelines

To ensure reliability of the device, following common printed-circuit-board layout guidelines is recommended.

- Bypass capacitors must be used on power supplies.
- Short trace lengths must be used to avoid excessive loading.
- Place pads on the signal paths for loading capacitors or pullup resistors to help adjust rise and fall times of signals, depending on the system requirements.

### 12.2 Layout Example

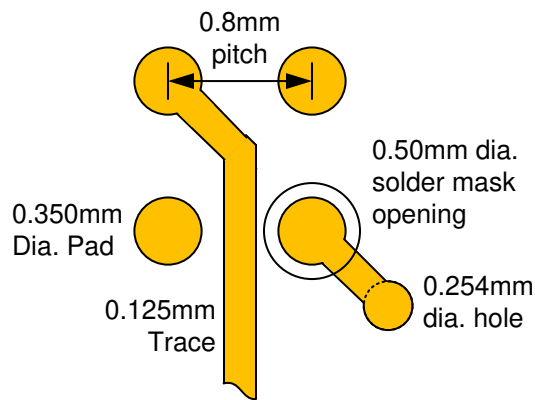


Figure 12-1. BGA Layout Example

## 13 Device and Documentation Support

### 13.1 Documentation Support

#### 13.1.1 Related Documentation

For related documentation, see the following:

<http://www.ti.com/lit/an/scea014/scea014.pdf>

### 13.2 Receiving Notification of Documentation Updates

To receive notification of documentation updates, navigate to the device product folder on [ti.com](http://www.ti.com). Click on *Subscribe to updates* to register and receive a weekly digest of any product information that has changed. For change details, review the revision history included in any revised document.

### 13.3 Support Resources

[TI E2E™ support forums](#) are an engineer's go-to source for fast, verified answers and design help — straight from the experts. Search existing answers or ask your own question to get the quick design help you need.

Linked content is provided "AS IS" by the respective contributors. They do not constitute TI specifications and do not necessarily reflect TI's views; see TI's [Terms of Use](#).

### 13.4 Trademarks

Widebus+™ is a trademark of Texas Instruments.

TI E2E™ is a trademark of Texas Instruments.

All trademarks are the property of their respective owners.

### 13.5 Electrostatic Discharge Caution



This integrated circuit can be damaged by ESD. Texas Instruments recommends that all integrated circuits be handled with appropriate precautions. Failure to observe proper handling and installation procedures can cause damage.

ESD damage can range from subtle performance degradation to complete device failure. Precision integrated circuits may be more susceptible to damage because very small parametric changes could cause the device not to meet its published specifications.

### 13.6 Glossary

[TI Glossary](#) This glossary lists and explains terms, acronyms, and definitions.

## 14 Mechanical, Packaging, and Orderable Information

The following pages include mechanical, packaging, and orderable information. This information is the most current data available for the designated devices. This data is subject to change without notice and revision of this document. For browser-based versions of this data sheet, refer to the left-hand navigation.

**PACKAGING INFORMATION**

Orderable Device	Status (1)	Package Type	Package Drawing	Pins	Package Qty	Eco Plan (2)	Lead finish/ Ball material (6)	MSL Peak Temp (3)	Op Temp (°C)	Device Marking (4/5)	Samples
SN74AVC32T245NMJR	ACTIVE	NFBGA	NMJ	96	1000	RoHS & Green	SNAGCU	Level-3-260C-168 HR	-40 to 85	29UW	Samples

(1) The marketing status values are defined as follows:

**ACTIVE:** Product device recommended for new designs.

**LIFEBUY:** TI has announced that the device will be discontinued, and a lifetime-buy period is in effect.

**NRND:** Not recommended for new designs. Device is in production to support existing customers, but TI does not recommend using this part in a new design.

**PREVIEW:** Device has been announced but is not in production. Samples may or may not be available.

**OBSOLETE:** TI has discontinued the production of the device.

(2) **RoHS:** TI defines "RoHS" to mean semiconductor products that are compliant with the current EU RoHS requirements for all 10 RoHS substances, including the requirement that RoHS substance do not exceed 0.1% by weight in homogeneous materials. Where designed to be soldered at high temperatures, "RoHS" products are suitable for use in specified lead-free processes. TI may reference these types of products as "Pb-Free".

**RoHS Exempt:** TI defines "RoHS Exempt" to mean products that contain lead but are compliant with EU RoHS pursuant to a specific EU RoHS exemption.

**Green:** TI defines "Green" to mean the content of Chlorine (Cl) and Bromine (Br) based flame retardants meet JS709B low halogen requirements of <=1000ppm threshold. Antimony trioxide based flame retardants must also meet the <=1000ppm threshold requirement.

(3) MSL, Peak Temp. - The Moisture Sensitivity Level rating according to the JEDEC industry standard classifications, and peak solder temperature.

(4) There may be additional marking, which relates to the logo, the lot trace code information, or the environmental category on the device.

(5) Multiple Device Markings will be inside parentheses. Only one Device Marking contained in parentheses and separated by a "-" will appear on a device. If a line is indented then it is a continuation of the previous line and the two combined represent the entire Device Marking for that device.

(6) Lead finish/Ball material - Orderable Devices may have multiple material finish options. Finish options are separated by a vertical ruled line. Lead finish/Ball material values may wrap to two lines if the finish value exceeds the maximum column width.

**Important Information and Disclaimer:**The information provided on this page represents TI's knowledge and belief as of the date that it is provided. TI bases its knowledge and belief on information provided by third parties, and makes no representation or warranty as to the accuracy of such information. Efforts are underway to better integrate information from third parties. TI has taken and continues to take reasonable steps to provide representative and accurate information but may not have conducted destructive testing or chemical analysis on incoming materials and chemicals. TI and TI suppliers consider certain information to be proprietary, and thus CAS numbers and other limited information may not be available for release.

In no event shall TI's liability arising out of such information exceed the total purchase price of the TI part(s) at issue in this document sold by TI to Customer on an annual basis.

**TAPE AND REEL INFORMATION**

**QUADRANT ASSIGNMENTS FOR PIN 1 ORIENTATION IN TAPE**

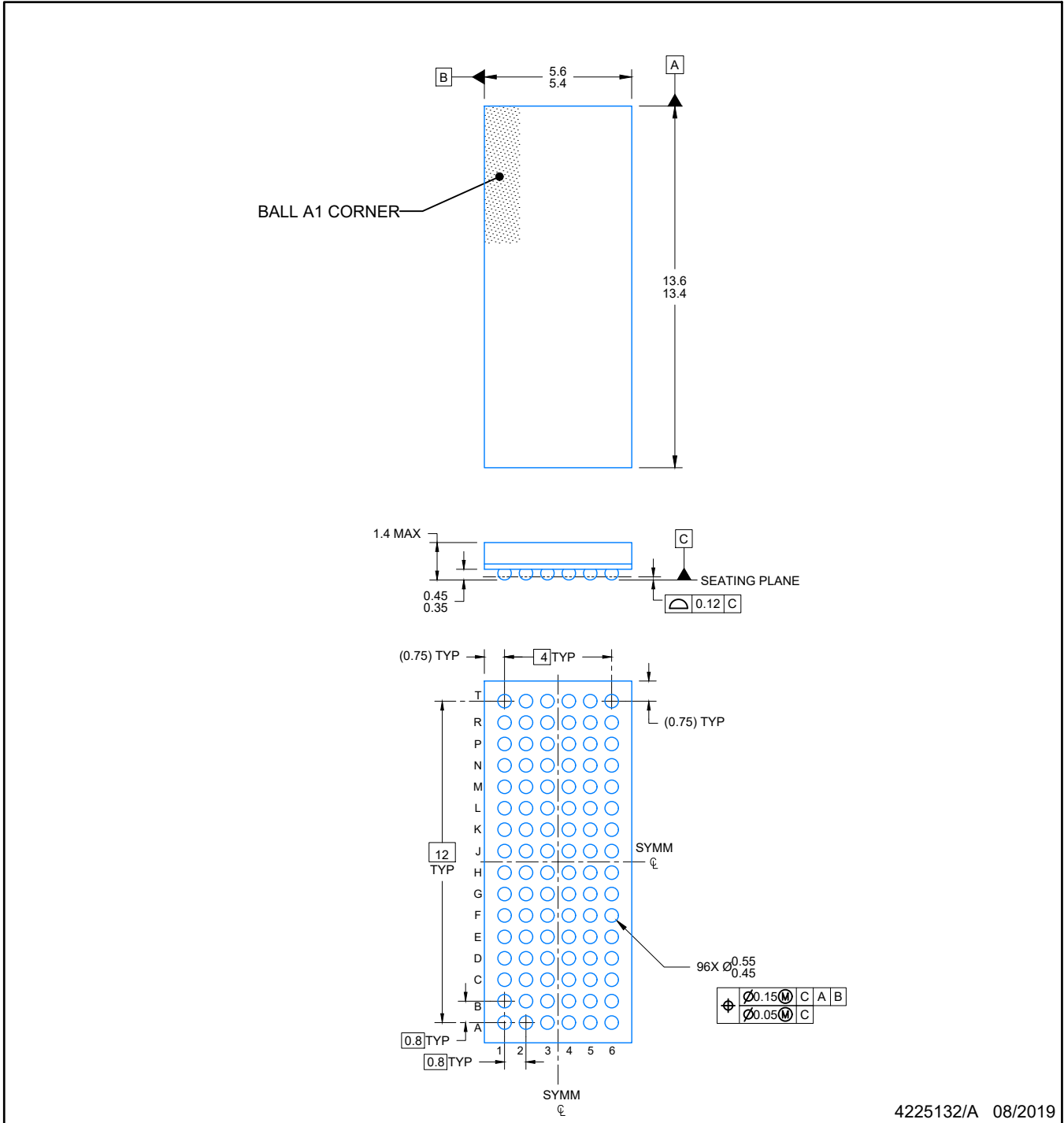

\*All dimensions are nominal

Device	Package Type	Package Drawing	Pins	SPQ	Reel Diameter (mm)	Reel Width W1 (mm)	A0 (mm)	B0 (mm)	K0 (mm)	P1 (mm)	W (mm)	Pin1 Quadrant
SN74AVC32T245NMJR	NFBGA	NMJ	96	1000	330.0	24.4	5.85	13.85	1.8	8.0	24.0	Q1

**TAPE AND REEL BOX DIMENSIONS**


\*All dimensions are nominal

Device	Package Type	Package Drawing	Pins	SPQ	Length (mm)	Width (mm)	Height (mm)
SN74AVC32T245NMJR	NFBGA	NMJ	96	1000	336.6	336.6	41.3



4225132/A 08/2019

NOTES:

NanoFree is a trademark of Texas Instruments.

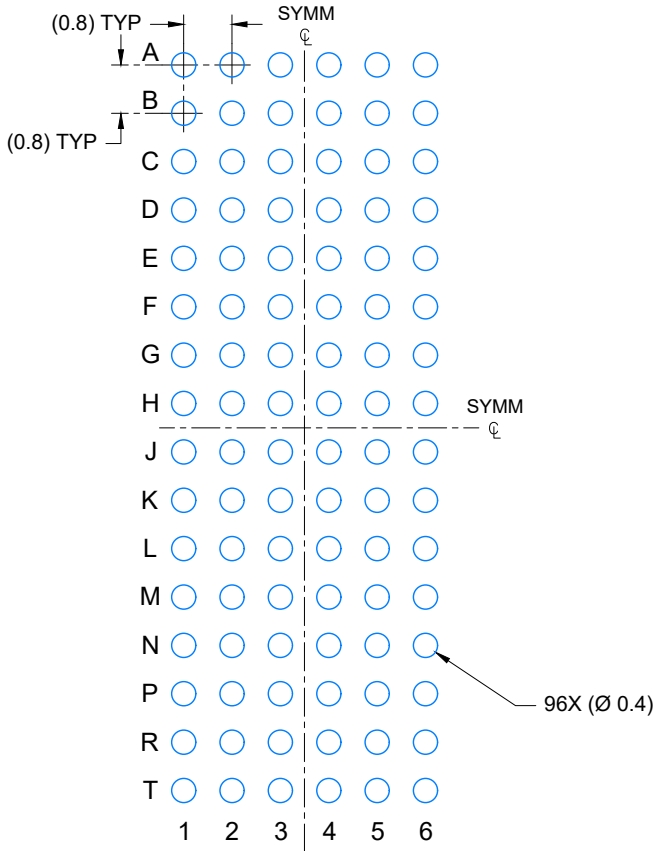
1. All linear dimensions are in millimeters. Any dimensions in parenthesis are for reference only. Dimensioning and tolerancing per ASME Y14.5M.
2. This drawing is subject to change without notice.

# EXAMPLE BOARD LAYOUT

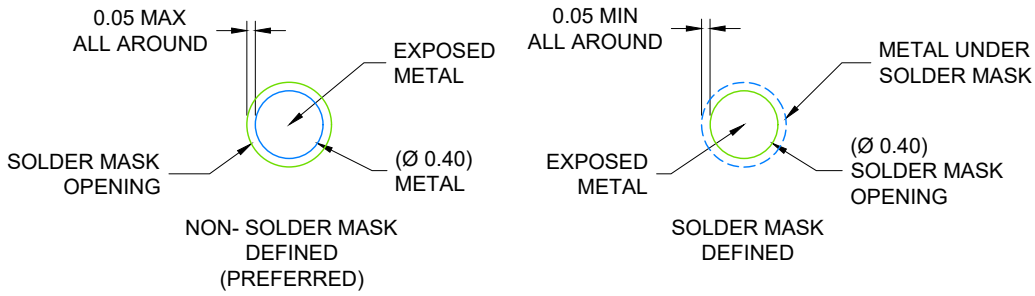
NMJ0096A

NFBGA - 1.4 mm max height

PLASTIC BALL GRID ARRAY



LAND PATTERN EXAMPLE  
SCALE: 8X



SOLDER MASK DETAILS  
NOT TO SCALE

4225132/A 08/2019

NOTES: (continued)

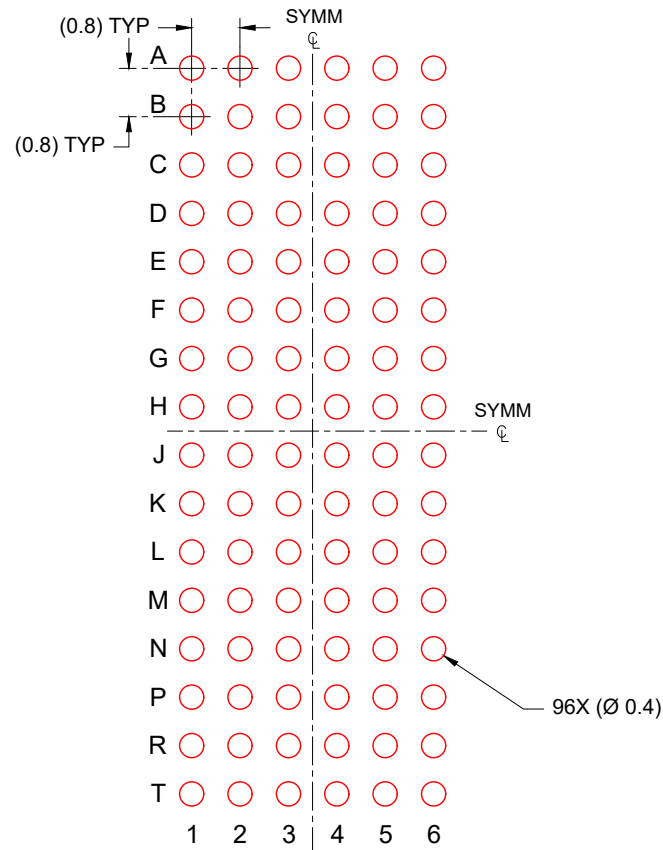
- 3. Final dimensions may vary due to manufacturing tolerance considerations and also routing constraints. Refer to Texas Instruments Literature number SNVA009 ([www.ti.com/lit/snva009](http://www.ti.com/lit/snva009)).

# EXAMPLE STENCIL DESIGN

NMJ0096A

NFBGA - 1.4 mm max height

PLASTIC BALL GRID ARRAY



SOLDER PASTE EXAMPLE  
BASED ON 0.150 mm THICK STENCIL  
SCALE: 8X

4225132/A 08/2019

NOTES: (continued)

4. Laser cutting apertures with trapezoidal walls and rounded corners may offer better paste release.

## IMPORTANT NOTICE AND DISCLAIMER

TI PROVIDES TECHNICAL AND RELIABILITY DATA (INCLUDING DATA SHEETS), DESIGN RESOURCES (INCLUDING REFERENCE DESIGNS), APPLICATION OR OTHER DESIGN ADVICE, WEB TOOLS, SAFETY INFORMATION, AND OTHER RESOURCES "AS IS" AND WITH ALL FAULTS, AND DISCLAIMS ALL WARRANTIES, EXPRESS AND IMPLIED, INCLUDING WITHOUT LIMITATION ANY IMPLIED WARRANTIES OF MERCHANTABILITY, FITNESS FOR A PARTICULAR PURPOSE OR NON-INFRINGEMENT OF THIRD PARTY INTELLECTUAL PROPERTY RIGHTS.

These resources are intended for skilled developers designing with TI products. You are solely responsible for (1) selecting the appropriate TI products for your application, (2) designing, validating and testing your application, and (3) ensuring your application meets applicable standards, and any other safety, security, regulatory or other requirements.

These resources are subject to change without notice. TI grants you permission to use these resources only for development of an application that uses the TI products described in the resource. Other reproduction and display of these resources is prohibited. No license is granted to any other TI intellectual property right or to any third party intellectual property right. TI disclaims responsibility for, and you will fully indemnify TI and its representatives against, any claims, damages, costs, losses, and liabilities arising out of your use of these resources.

TI's products are provided subject to [TI's Terms of Sale](#) or other applicable terms available either on [ti.com](https://www.ti.com) or provided in conjunction with such TI products. TI's provision of these resources does not expand or otherwise alter TI's applicable warranties or warranty disclaimers for TI products.

TI objects to and rejects any additional or different terms you may have proposed.

Mailing Address: Texas Instruments, Post Office Box 655303, Dallas, Texas 75265  
Copyright © 2023, Texas Instruments Incorporated

## Looking for pricing, stock, or lifecycle information?

Click below to explore more details on WIN SOURCE:

 [View SN74AVC32T245GKER on WIN SOURCE](#)

 [Texas Instruments](#) Information

## Optimize Your Supply Chain with WIN SOURCE Solutions

-  Global Sourcing Solution
-  Obsolete Management
-  Cost Control Management
-  Shortage Management
-  Alternative Solution
-  Excess Inventory Management