



**THE DATASHEET OF
AD7535JN**



FEATURES

All Grades 14-Bit Monotonic over the Full Temperature Range
Full 4 Quadrant Multiplication
Microprocessor Compatible with Double Buffered Inputs
Exceptionally Low Gain Temperature Coefficient, 0.5ppm/°C typ
Low Output Leakage (<20nA) over the Full Temperature Range

APPLICATIONS

Microprocessor Based Control Systems
Digital Audio
Precision Servo Control
Control and Measurement in High Temperature Environments

GENERAL DESCRIPTION

The AD7535 is a 14-bit monolithic CMOS D/A converter which uses laser trimmed thin-film resistors to achieve excellent linearity.

Standard Chip Select and Memory Write logic is used to access the DAC.

A novel low leakage configuration (patent pending) enables the AD7535 to exhibit excellent output leakage current characteristics over the specified temperature range.

The device is fully protected against CMOS "latch up" phenomena and does not require the use of external Schottky diodes or the use of a FET Input op-amp. The AD7535 is manufactured using the Linear Compatible CMOS (LC²MOS) process. It is speed compatible with most microprocessors and accepts TTL or CMOS logic level inputs.

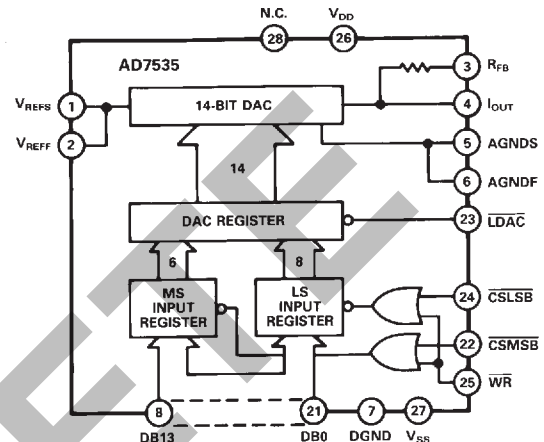
FUNCTIONAL BLOCK DIAGRAM

PRODUCT HIGHLIGHTS

- Guaranteed Monotonicity**
The AD7535 is guaranteed monotonic to 14-bits over the full temperature range for all grades.
- Low Output Leakage**
By tying V_{SS} (Pin 27) to a negative voltage, it is possible to achieve a low output leakage current at high temperatures.
- Microprocessor Compatibility**
High speed input control (TTL/5V CMOS compatible) allows direct interfacing to most of the popular 8-bit and 16-bit microprocessors. When interfacing to 8-bit processors CSMSB and CSLSB are separate and the 8-bit data bus is connected to both the MS Input Register and the LS Input Register. For straight 14-bit parallel loading CSMSB and CSLSB are tied together giving one chip select to load the 14-bit word.

REV. A

Information furnished by Analog Devices is believed to be accurate and reliable. However, no responsibility is assumed by Analog Devices for its use, nor for any infringements of patents or other rights of third parties which may result from its use. No license is granted by implication or otherwise under any patent or patent rights of Analog Devices.

One Technology Way, P.O. Box 9106, Norwood, MA 02062-9106
Tel: 617/329-4700 Fax: 617/326-8703 Twx: 710/394-6577
West Coast Central Atlantic
714/641-9391 214/231-5094 215/643-7790

AD7535—SPECIFICATIONS¹ ($V_{DD} = +11.4V$ to $+15.75V^2$, $V_{REF} = +10V$, $V_{PIN4} = V_{PIN5} = 0V$, $V_{SS} = -300mV$ All specifications T_{min} to T_{max} unless otherwise stated.)

Parameter	J, A Versions	K, B Versions	S Version	T Version	Units	Test Conditions/Comments
ACCURACY						
Resolution	14	14	14	14	Bits	All grades guaranteed monotonic over temperature. Measured using internal R_{FB} and includes effects of leakage current and gain T.C.
Relative Accuracy	± 2	± 1	± 2	± 1	LSB max	
Differential Nonlinearity	± 1	± 1	± 1	± 1	LSB max	
Full Scale Error	± 8	± 4	± 8	± 4	LSB max	
Gain Temperature Coefficient ³ ; Δ Gain/ Δ Temperature	± 5	± 2.5	± 5	± 2.5	ppm/ $^{\circ}C$ max	Typical value is 0.5ppm/ $^{\circ}C$
Output Leakage Current I_{OUT} (Pin 4) + 25 $^{\circ}C$	± 5	± 5	± 5	± 5	nA max	All digital inputs 0V $V_{SS} = -300mV$ $V_{SS} = 0V$
T_{min} to T_{max}	± 10	± 10	± 20	± 20	nA max	
T_{min} to T_{max}	± 25	± 25	± 150	± 150	nA max	
REFERENCE INPUT						
Input resistance, pin 1	3.5 10	3.5 10	3.5 10	3.5 10	k Ω min k Ω max	Typical Input Resistance = 6k Ω
DIGITAL INPUTS						
V_{IH} (Input High Voltage)	2.4	2.4	2.4	2.4	V min	$V_{IN} = 0V$ or V_{DD}
V_{IL} (Input Low Voltage)	0.8	0.8	0.8	0.8	V max	
I_{IN} (Input Current) + 25 $^{\circ}C$	± 1	± 1	± 1	± 1	μA max	
T_{min} to T_{max}	± 10	± 10	± 10	± 10	μA max	
C_{IN} (Input Capacitance) ³	7	7	7	7	pF max	
POWER SUPPLY						
V_{DD} Range	11.4/15.75	11.4/15.75	11.4/15.75	11.4/15.75	V_{min}/V_{max}	Specification guaranteed over this range All digital inputs V_{IL} or V_{IH} All digital inputs 0V or V_{DD}
V_{SS} Range	-200/-500	-200/-500	-200/-500	-200/-500	mV min/mV max	
I_{DD}	4	4	4	4	mA max	
	500	500	500	500	μA max	

These characteristics are included for Design Guidance only and are not subject to test.
($V_{DD} = +11.4V$ to $+15.75V$, $V_{REF} = +10V$, $V_{PIN4} = V_{PIN5} = 0V$, $V_{SS} = 0V$ OR $-300mV$,
Output Amplifier is AD544 except where stated.)

AC PERFORMANCE CHARACTERISTICS

Parameter	$T_A = 25^{\circ}C$ $T_A = T_{min}, T_{max}$	Units	Test Conditions/Comments
Output Current Settling Time	1.5	μs max	To 0.003% of full scale range. I_{OUT} load = 100 Ω , $C_{EXT} = 13pF$. DAC register alternately loaded with all 1's and all 0's. Typical value of Settling Time is 0.8 μs .
Digital to Analog Glitch Impulse	50	nV-sec typ	Measured with $V_{REF} = 0V$. I_{OUT} load = 100 Ω , $C_{EXT} = 13pF$. DAC register alternately loaded with all 1's and all 0's.
Multiplying Feedthrough Error ⁴	3	5	mV p-p typ $V_{REF} = \pm 10V$, 10kHz sine wave DAC register loaded with all 0's.
Power Supply Rejection Δ Gain/ ΔV_{DD}	± 0.01	± 0.02	% per % max $\Delta V_{DD} = \pm 5\%$
Output Capacitance C_{OUT} (Pin 4)	260	260	pF max DAC register loaded with all 1's
C_{OUT} (Pin 4)	130	130	pF max DAC register loaded with all 0's
Output Noise Voltage Density (10Hz - 100kHz)	15	-	nV \sqrt{Hz} typ Measured between R_{FB} and I_{OUT}

NOTES

¹Temperature range as follows: J, K Versions: 0 to +70 $^{\circ}C$
A, B Versions: -25 $^{\circ}C$ to +85 $^{\circ}C$
S, T Versions: -55 $^{\circ}C$ to +125 $^{\circ}C$

²Specifications are guaranteed for a V_{DD} of +11.4V to +15.75V. At $V_{DD} = 5V$, the device is fully functional with degraded specifications.

³Guaranteed by Product Assurance testing.

⁴Feedthrough can be further reduced by connecting the metal lid on the ceramic package to DGND.

Specifications subject to change without notice.

TIMING CHARACTERISTICS¹ ($V_{DD} = +11.4V$ to $+15.75V$, $V_{REF} = +10V$, $V_{PIN4} = V_{PIN5} = 0V$, $V_{SS} = 0V$ or $-300mV$)

All specifications T_{min} to T_{max} unless otherwise stated. See Figure 1 for Timing Diagram.)

Parameter	Limit at $T_A = 25^\circ C$	Limit at $T_A = 0$ to $+70^\circ C$ $T_A = -25^\circ C$ to $+85^\circ C$	Limit at $T_A = -55^\circ C$ to $+125^\circ C$	Units	Test Conditions/Comments
t_1	0	0	0	ns min	CSMSB or CSLSB to \overline{WR} Setup Time
t_2	0	0	0	ns min	CSMSB or CSLSB to \overline{WR} Hold Time
t_3	170	200	240	ns min	LDAC Pulse Width
t_4	170	200	240	ns min	Write Pulse Width
t_5	140	160	180	ns min	Data Setup Time
t_6	20	20	30	ns min	Data Hold Time

NOTES

¹Temperature range as follows: JN, KN Versions: 0 to $+70^\circ C$
 AQ, BQ Versions: $-25^\circ C$ to $+85^\circ C$
 SQ, TQ Versions: $-55^\circ C$ to $+125^\circ C$

Specifications subject to change without notice.

ABSOLUTE MAXIMUM RATINGS

($T_A = 25^\circ C$ unless otherwise stated)

V_{DD} (pin 26) to DGND	$-0.3V$, $+17V$
V_{SS} (pin 27) to AGND	$-15V$, $+0.3V$
V_{REFS} (pin 1) to AGND	$\pm 25V$
V_{REFE} (pin 2) to AGND	$\pm 25V$
V_{RFB} (pin 3) to AGND	$\pm 25V$
Digital Input Voltage (pins 8–25) to DGND	$-0.3V$, V_{DD}
V_{PIN4} to DGND	$-0.3V$, V_{DD}
AGND to DGND	$-0.3V$, V_{DD}
Power Dissipation (Any Package)	
To $+75^\circ C$	1000mW
Derates above $+75^\circ C$	10mW/ $^\circ C$

Operating Temperature Range

Commercial Plastic (J, K Versions)	0 to $+70^\circ C$
Industrial Ceramic (A, B Versions)	$-25^\circ C$ to $+85^\circ C$
Extended Ceramic (S, T Versions)	$-55^\circ C$ to $+125^\circ C$
Storage Temperature	$-65^\circ C$ to $+150^\circ C$
Lead Temperature (Soldering, 10 secs)	$+300^\circ C$

*Stresses above those listed under "Absolute Maximum Ratings" may cause permanent damage to the device. This is a stress rating only and functional operation of the device at these or any other conditions above those indicated in the operational sections of this specification is not implied. Exposure to absolute maximum rating conditions for extended periods may affect device reliability.

CAUTION

ESD (electrostatic discharge) sensitive device. The digital control inputs are diode protected; however, permanent damage may occur on unconnected devices subject to high energy electrostatic fields. Unused devices must be stored in conductive foam or shunts. The protective foam should be discharged to the destination socket before devices are removed.



ORDERING GUIDE

Model	Temperature Range	Relative Accuracy	Full-Scale Error	Package Option*
AD7535JN	$0^\circ C$ to $+70^\circ C$	$\pm 2LSB$	$\pm 8LSB$	N-28
AD7535KN	$0^\circ C$ to $+70^\circ C$	$\pm 1LSB$	$\pm 4LSB$	N-28
AD7535JP	$0^\circ C$ to $+70^\circ C$	$\pm 2LSB$	$\pm 8LSB$	P-28A
AD7535KP	$0^\circ C$ to $+70^\circ C$	$\pm 1LSB$	$\pm 4LSB$	P-28A
AD7535AQ	$-25^\circ C$ to $+85^\circ C$	$\pm 2LSB$	$\pm 8LSB$	Q-28
AD7535BQ	$-25^\circ C$ to $+85^\circ C$	$\pm 1LSB$	$\pm 4LSB$	Q-28
AD7535SQ	$-55^\circ C$ to $+125^\circ C$	$\pm 2LSB$	$\pm 8LSB$	Q-28
AD7535TQ	$-55^\circ C$ to $+125^\circ C$	$\pm 1LSB$	$\pm 4LSB$	Q-28
AD7535SE	$-55^\circ C$ to $+125^\circ C$	$\pm 2LSB$	$\pm 8LSB$	E-28A
AD7535TE	$-55^\circ C$ to $+125^\circ C$	$\pm 1LSB$	$\pm 4LSB$	E-28A

*E = Leadless Ceramic Chip Carrier; N = Plastic DIP; P = Plastic Leaded Chip Carrier; Q = Cerdip.

AD7535

TERMINOLOGY

RELATIVE ACCURACY

Relative accuracy or end-point nonlinearity is a measure of the maximum deviation from a straight line passing through the end-points of the DAC transfer function. It is measured after adjusting for zero error and full scale error and is normally expressed in Least Significant Bits or as a percentage of full scale reading.

DIFFERENTIAL NONLINEARITY

Differential nonlinearity is the difference between the measured change and the ideal 1LSB change between any two adjacent codes. A specified differential nonlinearity of ± 1 LSB max over the operating temperature range ensures monotonicity.

FULL-SCALE ERROR

Full scale error or gain error is a measure of the output error between an ideal DAC and the actual device output. Full scale error is adjustable to zero with an external potentiometer.

DIGITAL-TO-ANALOG GLITCH IMPULSE

The amount of charge injected from the digital inputs to the analog output when the inputs change state is called Digital-to-Analog Glitch Impulse. This is normally specified as the area of the glitch in either pA-secs or nV-secs depending upon whether the glitch is measured as a current or voltage. It is measured with $V_{REF} = AGND$.

OUTPUT CAPACITANCE

This is the capacitance from I_{OUT} to AGND.

OUTPUT LEAKAGE CURRENT

Output Leakage Current is current which appears at I_{OUT} with the DAC register loaded to all 0's.

MULTIPLYING FEEDTHROUGH ERROR

This is the ac error due to capacitive feedthrough from V_{REF} terminal to I_{OUT} with DAC register loaded to all zeros.

PIN CONFIGURATIONS

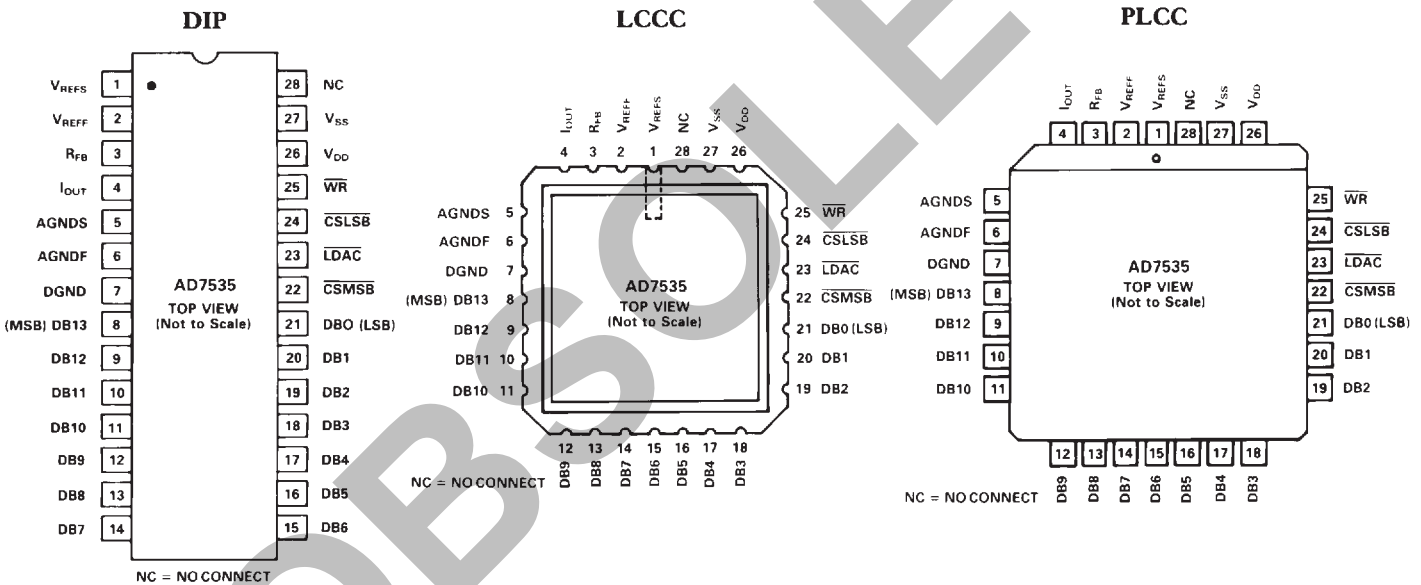

Pin	Function	Description
1	V _{REFS}	Voltage Reference sense pin
2	V _{REFF}	Voltage Reference force pin. If a remote voltage reference is being used V _{REFF} and V _{REFS} can be used in a Kelvin configuration to compensate for IR drop along the V _{REF} line. See Figure 7.
3	R _{FB}	Feedback resistor. Used to close the loop around an external op-amp.
4	I _{OUT}	Current Output Terminal.
5	A _{GNDS}	Analog ground sense line. Reference point for external circuitry. This pin should carry minimal current.
6	A _{GNDF}	Analog ground force line; carries current from internal analog ground connections. A _{GNDF} and A _{GNDS} are tied together internally.
7	DGND	Digital Ground
8	DB13	Data Bit 13. DAC MSB
9	DB12	Data Bit 12
10	DB11	Data Bit 11
11	DB10	Data Bit 10
12	DB9	Data Bit 9
13	DB8	Data Bit 8
14	DB7	Data Bit 7
15	DB6	Data Bit 6
16	DB5	Data Bit 5
17	DB4	Data Bit 4
18	DB3	Data Bit 3
19	DB2	Data Bit 2
20	DB1	Data Bit 1
21	DB0	Data Bit 0. DAC LSB
22	<u>CSMSB</u>	Chip Select Most Significant (MS) Byte. Active LOW input.
23	<u>LDAC</u>	Asynchronous Load DAC input. Active LOW.
24	<u>CSLSB</u>	Chip Select Least Significant (LS) Byte. Active LOW input.
25	<u>WR</u>	Write input. Active LOW.

<u>CSMSB</u>	<u>CSLSB</u>	<u>LDAC</u>	<u>WR</u>	Operation
0	1	1	0	Load MS Input Register
1	0	1	0	Load LS Input Register
0	0	1	0	Load MS and LS Input Registers
1	1	0	X	Load DAC Register from Input Registers
0	0	0	0	All Registers are transparent
1	1	1	X	No operation
X	X	1	1	No operation

NOTE X = Don't Care

26	V _{DD}	+12V to +15V supply input
27	V _{SS}	Bias pin for High Temperature Low Leakage configuration. To implement low leakage system, the pin should be at a negative voltage. See Figure 4, 5, 6 or 7 for recommended circuitry.
28	N.C.	No connection

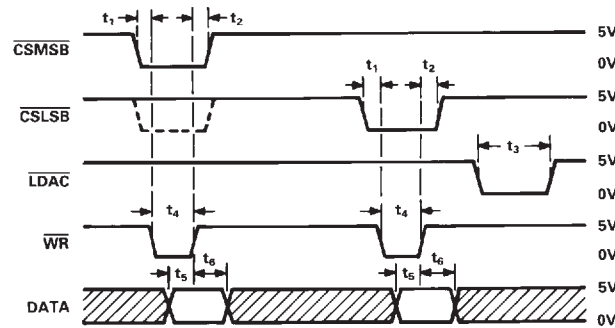

- NOTES
1. ALL INPUT SIGNAL RISE AND FALL TIMES MEASURED FROM 10% TO 90% OF +5V. $t_r = t_f = 20\text{ns}$.
 2. TIMING MEASUREMENT REFERENCE LEVEL IS $\frac{V_{IH} + V_{IL}}{2}$
 3. IF $\overline{\text{LDAC}}$ IS ACTIVATED PRIOR TO THE RISING EDGE OF $\overline{\text{WR}}$, THEN IT MUST STAY LOW FOR t_3 OR LONGER AFTER $\overline{\text{WR}}$ GOES HIGH.

Figure 1. AD7535 Timing Diagram

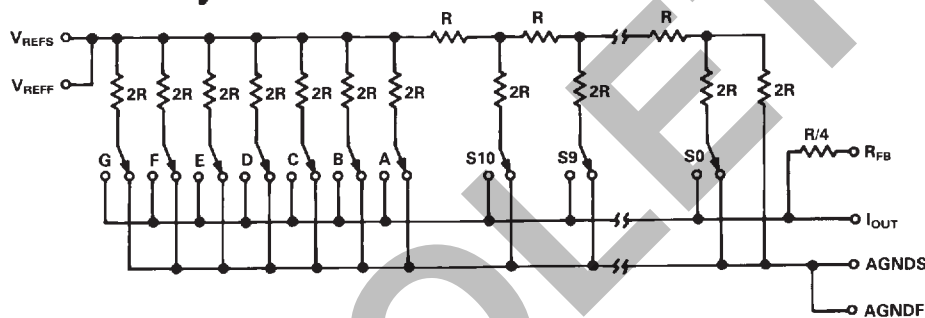

Figure 2. Simplified Circuit Diagram for the AD7535 D/A Section

CIRCUIT INFORMATION – D/A SECTION

Figure 2 shows a simplified circuit diagram for the AD7535 D/A section. The three MSB's of the 14-bit Data Word are decoded to drive the seven switches A-G. The 11 LSB's of the Data Word consist of an R-2R ladder operated in a current steering configuration.

The R-2R ladder current is 1/8 of the total reference input current. 7/8 I flows in the parallel ladder structure. Switches A-G steer equally weighted currents between I_{OUT} and $AGNDF$.

Since the input resistance at V_{REF} is constant, it may be driven by a voltage source or a current source of positive or negative polarity.

EQUIVALENT CIRCUIT ANALYSIS

Figure 3 shows an equivalent circuit for the analog section of the AD7535 D/A converter. The current source $I_{LEAKAGE}$ is composed of surface and junction leakages. The resistor R_O denotes the equivalent output resistance of the DAC which varies with input code. C_{OUT} is the capacitance due to the current steering switches and varies from about 90pF to 180pF (typical values) depending upon the digital input. $g(V_{REF}, N)$ is the Thevenin equivalent voltage generator due to the reference

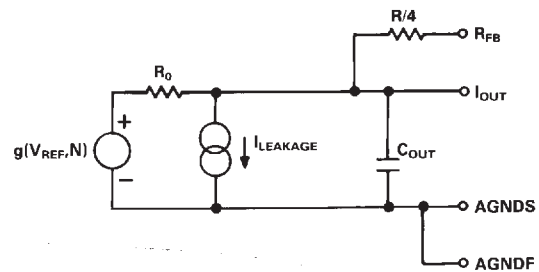

Figure 3. AD7535 Equivalent Analog Output Circuit

input voltage, V_{REF} , and the transfer function of the DAC ladder, N.

CIRCUIT INFORMATION – DIGITAL SECTION

The digital inputs are designed to be both TTL and 5V CMOS compatible. All logic inputs are static protected MOS gates with typical input currents of less than 1nA. Internal input protection is achieved by an on-chip distributed diode from DGND to each MOS gate. To minimize power supply currents, it is recommended that the digital input voltages be driven as close as possible to 0 and 5V logic levels.

UNIPOLAR BINARY OPERATION (2-QUADRANT MULTIPLICATION)

Figure 4 shows the circuit diagram for unipolar binary operation. With an ac input, the circuit performs 2 quadrant multiplication. The code table for Figure 4 is given in Table I.

Capacitor C1 provides phase compensation and helps prevent overshoot and ringing when high speed op-amps are used.

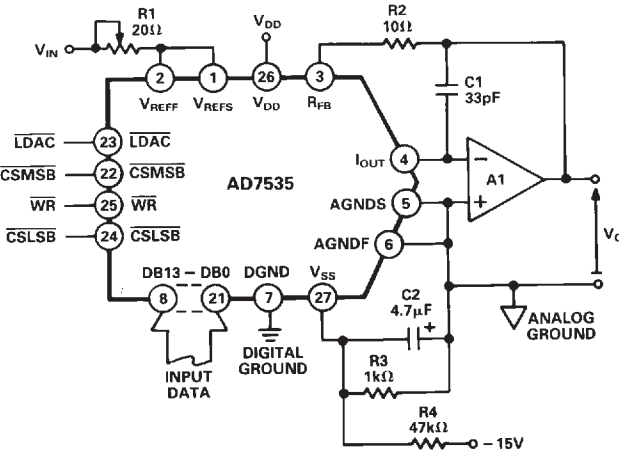

Figure 4. Unipolar Binary Operation

Binary Number In DAC Register		Analog Output, V_{OUT}
MSB	LSB	
11 1111	1111 1111	$-V_{IN} \left(\frac{16383}{16384} \right)$
10 0000	0000 0000	$-V_{IN} \left(\frac{8192}{16384} \right) = -1/2 V_{IN}$
00 0000	0000 0001	$-V_{IN} \left(\frac{1}{16384} \right)$
00 0000	0000 0000	0V

Table I. Unipolar Binary Code Table for AD7535

ZERO OFFSET AND GAIN ADJUSTMENT FOR FIGURE 4.

Zero Offset Adjustment

1. Load DAC register with all 0's.
2. Adjust offset of amplifier A1 so that V_O is at a minimum (i.e. $\leq 30\mu V$).

Gain Adjustment

1. Load DAC register with all 1's.
2. Trim potentiometer R1 so that $V_O = -V_{IN} \left(\frac{16383}{16384} \right)$

In fixed reference applications, full scale can also be adjusted by omitting R1 and R2 and trimming the reference voltage magnitude.

For high temperature applications resistors and potentiometers should have a low Temperature Coefficient. In many applications, because of the excellent Gain T.C. and Gain Error specifications of the AD7535, Gain Error trimming is not necessary.

BIPOLAR OPERATION (4-QUADRANT MULTIPLICATION)

The recommended circuit diagram for bipolar operation is shown in Figure 5. Offset binary coding is used.

With the DAC loaded to 10 0000 0000 0000, adjust R1 for $V_O = 0V$. Alternatively, one can omit R1 and R2 and adjust the ratio of R5 and R6 for $V_O = 0V$. Full scale trimming can be accomplished by adjusting the amplitude of V_{IN} or by varying the value of R7.

Resistors R5, R6 and R7 should be ratio matched to 0.006%. Mismatch of R5 and R6 causes both offset and full scale error. When operating over a wide temperature range, it is important that the resistors be of the same type so that their temperature coefficients match.

A range of precision voltage dividers, manufactured by Vishay, offers a suitable solution to implementing the bipolar circuit described above. The resistor networks are TCR and Ratio Matched, giving excellent performance over temperature.

The code table for Figure 5 is given in Table II.

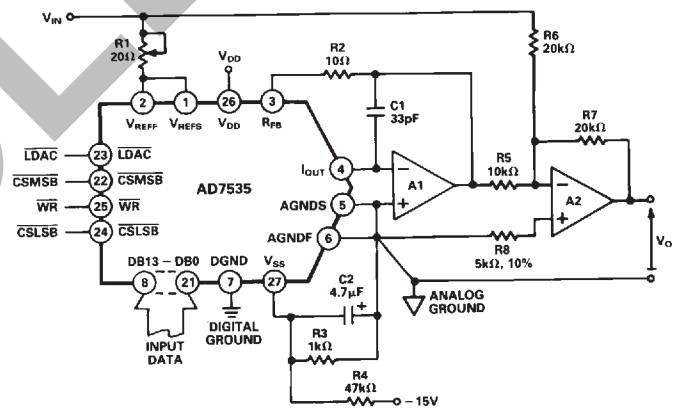

Figure 5. Bipolar Operation

Binary Number in DAC Register		Analog Output V_{OUT}
MSB	LSB	
11 1111	1111 1111	$+V_{IN} \left(\frac{8191}{8192} \right)$
10 0000	0000 0001	$+V_{IN} \left(\frac{1}{8192} \right)$
10 0000	0000 0000	0V
01 1111	1111 1111	$-V_{IN} \left(\frac{1}{8192} \right)$
00 0000	0000 0000	$-V_{IN} \left(\frac{8192}{8192} \right)$

Table II. Bipolar Code Table for Offset Binary Circuit of Figure 5.

AD7535

GROUNDING TECHNIQUES

Since the AD7535 is specified for high accuracy it is important to use a proper grounding technique. The two AGND pins (AGNDF and AGNDS) provide flexibility in this respect. In Figure 4, the AD7535 is connected with the signal ground for the load located close to the DAC. There is no possibility of a voltage drop along the signal ground due to track resistance.

If the signal ground for the load is located at a distance from the DAC then the configuration of Figure 6 should be used. A₂ compensates for the error due to IR voltage drop between the DAC's internal Analog ground and the load signal ground.

Figure 7 shows a remote voltage reference driving the AD7535. Op-amps A2 and A3 compensate for voltage drops along the reference input line and the analog ground line.

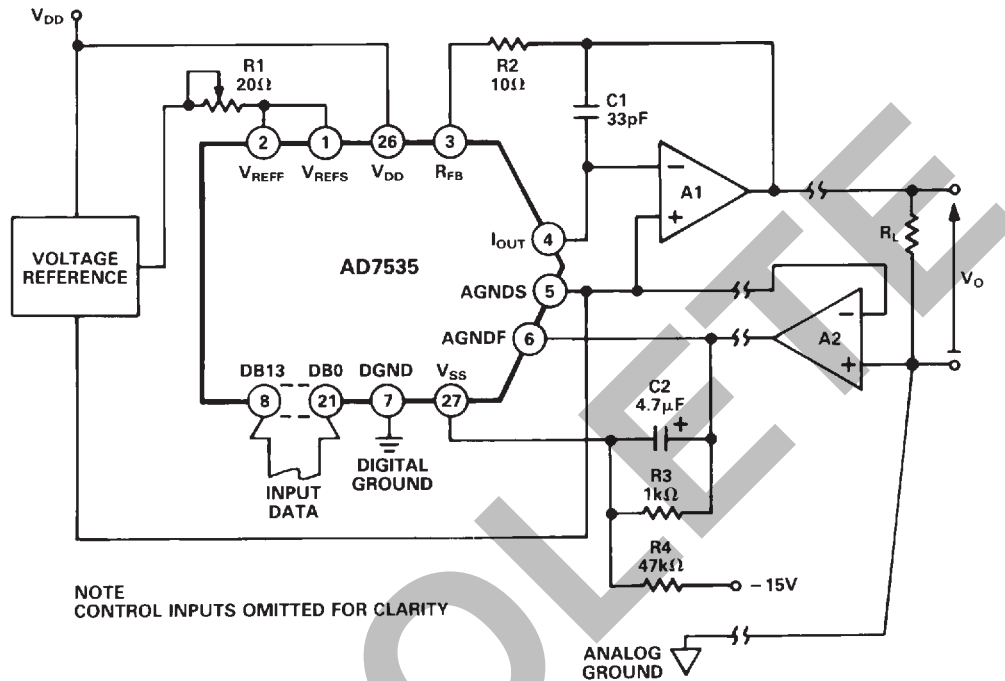

NOTE
CONTROL INPUTS OMITTED FOR CLARITY

Figure 6. Unipolar Binary Operation with Forced Ground for Remote Load

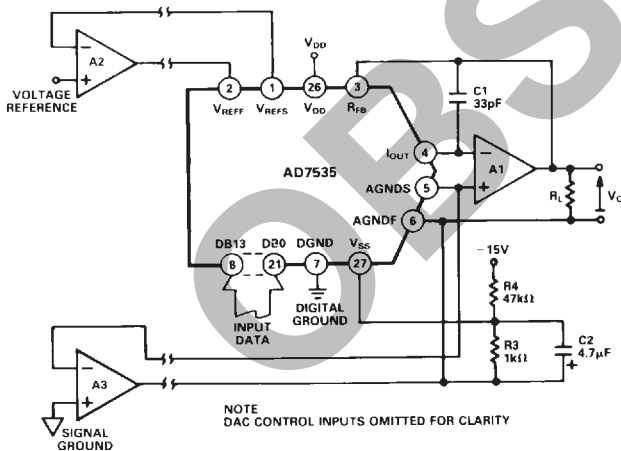

NOTE
DAC CONTROL INPUTS OMITTED FOR CLARITY

Figure 7. Driving the AD7535 with a Remote Voltage Reference

ZERO OFFSET AND GAIN ADJUSTMENT FOR FIGURE 6

Zero Offset Adjustment

1. Load DAC register with all 0's.
2. Adjust offset of amplifier A2 for a minimum potential at AGNDS. This potential should be $\leq 30\mu\text{V}$ with respect to Signal Ground. Adjust offset of amplifier A1 so that V_O is at a minimum (i.e. $\leq 30\mu\text{V}$).

Gain Adjustment

1. Load DAC register with all 1's.
2. Trim potentiometer R1 so that $V_O = -V_{IN} \frac{(16383)}{(16384)}$

LOW LEAKAGE CONFIGURATION

For CMOS Multiplying D/A converters, as the device is operated at higher temperatures the output leakage current increases. For a 14-bit resolution system, this can be a significant source of error. The AD7535 features a leakage reduction configuration (patent pending) to keep the leakage current low over an extended temperature range. One may operate the device with or without this configuration. If V_{SS} (pin 27) is tied to A_{GND} then the DAC will exhibit normal output leakage current at high temperatures. To use the low leakage facility, V_{SS} should be tied to a voltage of approximately $-0.3V$ as in Figures 4, 5, 6 and 7. A simple resistor divider ($R3, R4$) produces approximately $-300mV$ from $-15V$. The capacitor $C2$ in parallel with $R3$ is an integral part of the low leakage configuration and must be $4.7\mu F$ or greater. Figure 8 is a plot of leakage current versus temperature for both conditions. It clearly shows the improvement gained by using the low leakage configuration.

OP-AMP SELECTION

In choosing an amplifier to be used with the AD7535, three parameters are of prime importance. These are (1) Input Offset Voltage (V_{OS}), (2) Input Bias Current (I_B), (3) Offset Voltage

Drift ($TC V_{OS}$). To maintain specified accuracy with V_{REF} at $10V$, V_{OS} must be less than $30\mu V$ while I_B should be less than $2nA$. It is important that the amplifier Open Loop Gain, A_{VOL} , be sufficiently large to keep $V_{OS} \leq 30\mu V$ for the full output voltage range. For a maximum output of $10V$, A_{VOL} must be greater than $340,000$.

The AD OP-07 series of op-amps have a very low V_{OS} ($25\mu V$) and can be used as the output amplifier for the AD7535 without any external adjustment of Offset Voltage. In the Forced Ground configuration of Figure 6, one can use an AD OP-07 for amplifier A2. Settling time to 0.003% for the AD OP-07 is typically greater than $50\mu s$.

For faster settling time, one can use the AD544 series of op amps. Typically this settles to 0.003% (14-bits) in $5\mu s$. Even faster settling time can be achieved using the HA-2620 series of op-amps.

For operation over a wide temperature range Offset Voltage Drift and Bias Current Drift are critical parameters. The OP-27 and OP-37 series of op-amps exhibit extremely low Offset Voltage Drift and the AD544 has very low Bias Current Drift.

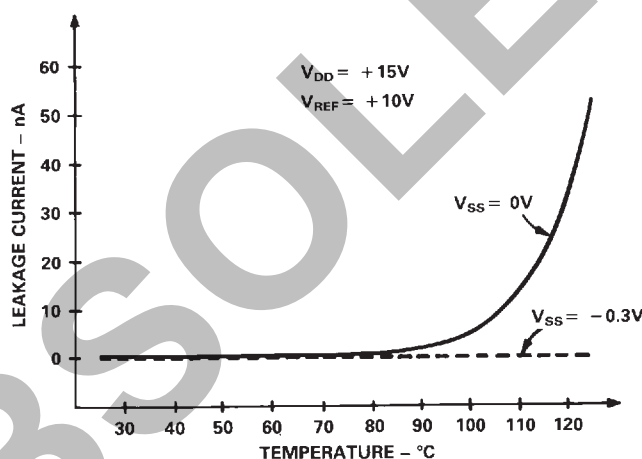

Figure 8. Graph of Typical Leakage Current vs Temperature for AD7535

AD7535

MICROPROCESSOR INTERFACING

AD7535 – 8086A INTERFACE

The versatility of the AD7535 loading structure allows interfacing to both 8- and 16-bit microprocessor systems. Figure 9 shows the 8086 16-bit processor interfacing to a single device. In this setup the double buffering feature of the DAC is not used. AD0-AD13 of the 16-bit data bus are connected to the DAC data bus (DB0-DB13). The 14-bit word is written to the DAC in one MOV instruction and the analog output responds immediately. In this example the DAC address is D000. A software routine for Figure 9 is given in Table III.

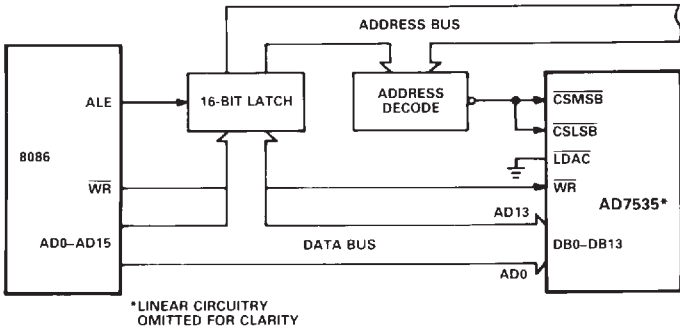

Figure 9. AD7535 – 8086 Interface Circuit

In a multiple DAC system the double buffering of the AD7535 allows the user to simultaneously update all DAC's. In Figure 10, a 14-bit word is loaded to the Input Registers of each of the DACs in sequence. Then, with one instruction to the appropriate address, CS4 (i.e. LDAC) is brought low, updating all the DACs simultaneously.

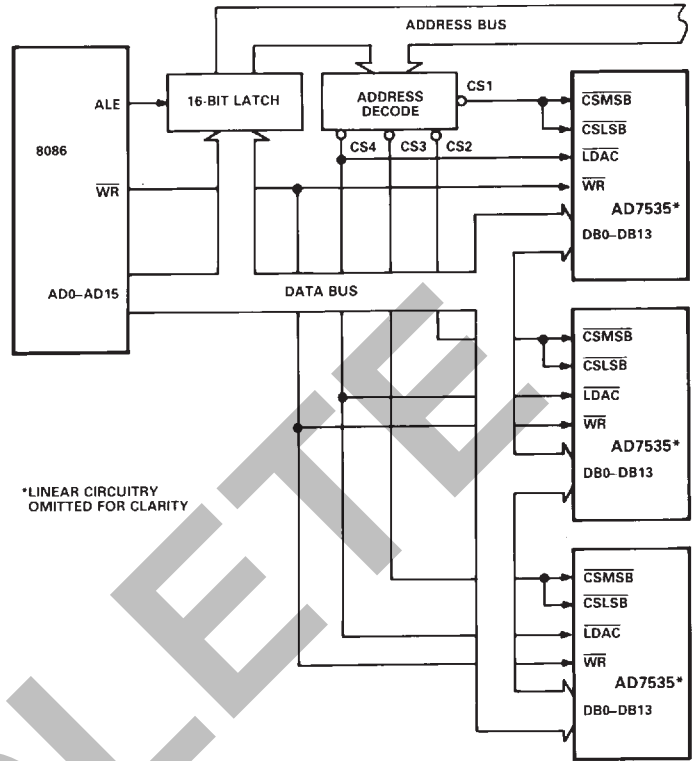

Figure 10. AD7535 – 8086 Interface: Multiple DAC System

**ASSUME DS: DACLOAD, CS : DACLOAD
DACLOAD SEGMENT AT 000**

00	8CC9	MOV CX,CS	: DEFINE DATA SEGMENT REGISTER EQUAL
02	8ED9	MOV DS,CX	: TO CODE SEGMENT REGISTER
04	BF00D0	MOV DI,# D000	: LOAD DI WITH D000
07	C705"YZWX"	MOV MEM,# YZWX"	: DAC LOADED WITH WXYZ
0B	EA0000		: CONTROL IS RETURNED TO THE
0E	00FF		MONITOR PROGRAM

Table III. Sample Program for Loading AD7535 from 8086

AD7535 – MC68000 INTERFACE

Interfacing between the MC68000 and the AD7535 is accomplished using the circuit of Figure 11. The following routine writes data to the DAC input registers and then outputs the data via the DAC register.

```

01000  MOVE.W    # W, D0      The desired DAC data, W, is loaded into
                                Data Register 0. W may be any value
                                between 0 and 16383 (decimal) or 0
                                and 3FFF (hexadecimal).

                                MOVE.W    D0, $E000      The data W is transferred between D0
                                and the DAC Register.

                                MOVE.B    # 228, D7      Control is returned to the System
                                Monitor Program using these two
                                instructions.

                                TRAP      # 14
    
```

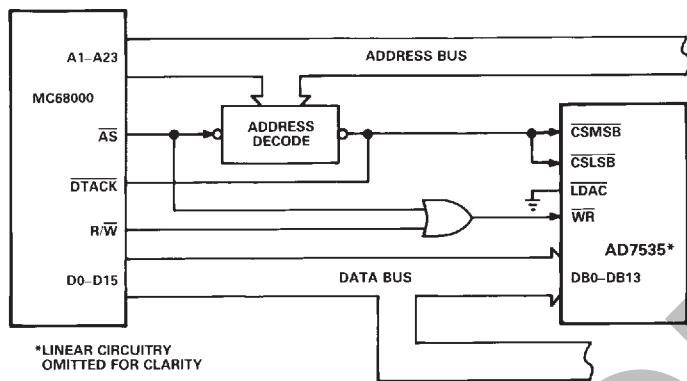

Figure 11. AD7535 – MC68000 Interface

AD7535 – Z80 INTERFACE

Though the AD7535 is primarily intended for use either with 16-bit microprocessors or in stand alone applications, it can also be interfaced to 8-bit processor systems. Figure 12 is an interface circuit for the Z80 microprocessor.

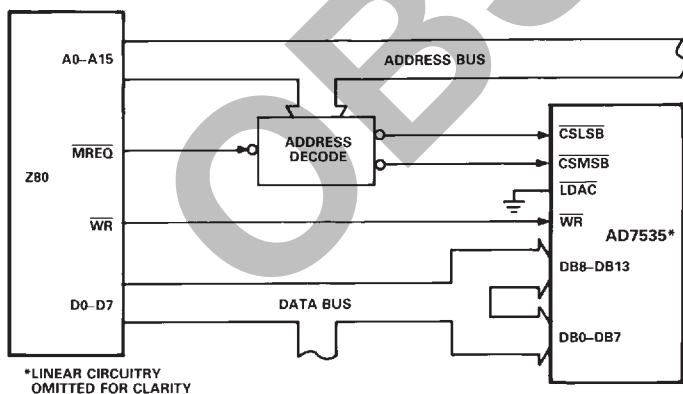

Figure 12. AD7535 – Z80 Interface

DIGITAL FEEDTHROUGH

In the preceding interface configurations, most digital inputs to the AD7535 are directly connected to the microprocessor bus. Even when the device is not selected, these inputs will be constantly changing. The high frequency logic activity on the bus can feed through the DAC package capacitance to show up as noise on the analog output. To minimize this Digital Feedthrough isolate the DAC from the noise source. Figure 13 shows an interface circuit which physically isolates the DAC from the bus. One may also use other means, such as peripheral interface devices, to reduce the Digital Feedthrough.

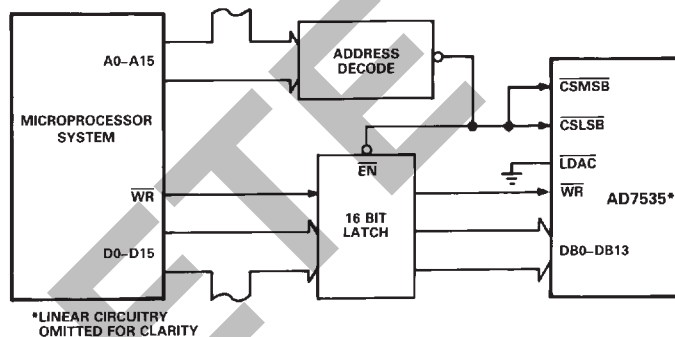

Figure 13. AD7535 Interface Circuit Using Latches to Minimize Digital Feedthrough

**MECHANICAL INFORMATION
OUTLINE DIMENSIONS**

Dimensions shown in inches and (mm).

28-Pin Ceramic DIP Package (D-28A)

28-Pin Plastic DIP (N-28)

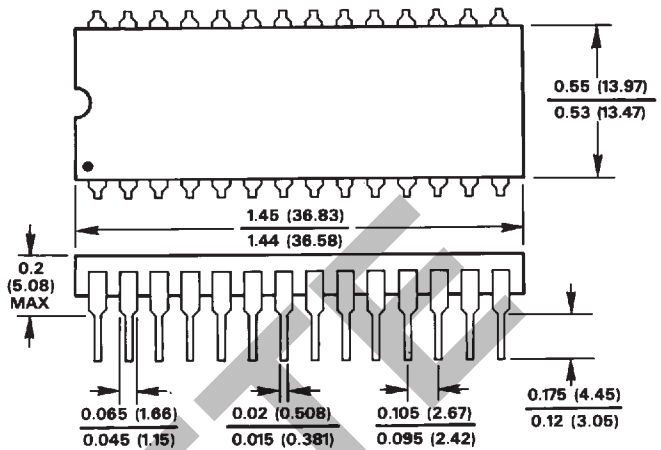
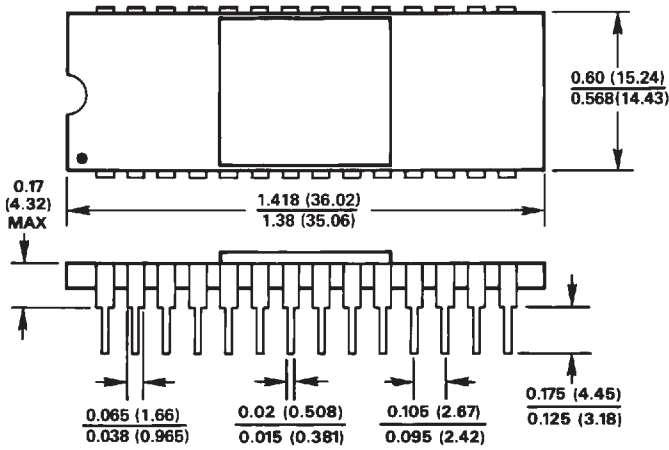

LEAD NO. 1 IDENTIFIED BY DOT OR NOTCH
LEADS ARE GOLD PLATED (50 MICROINCHES MIN) KOVAR OR ALLOY 42

LEAD NO. 1 IDENTIFIED BY DOT OR NOTCH
LEADS ARE SOLDER OR TIN PLATED KOVAR OR ALLOY 42

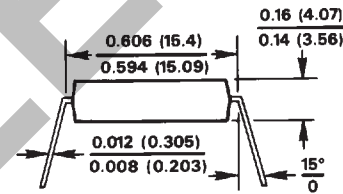
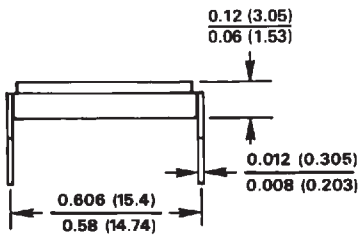

P-28A PLCC

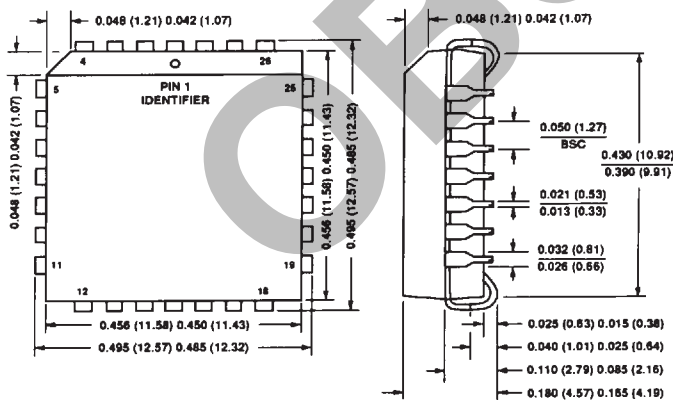

**E-28A)
LCCC E Package**

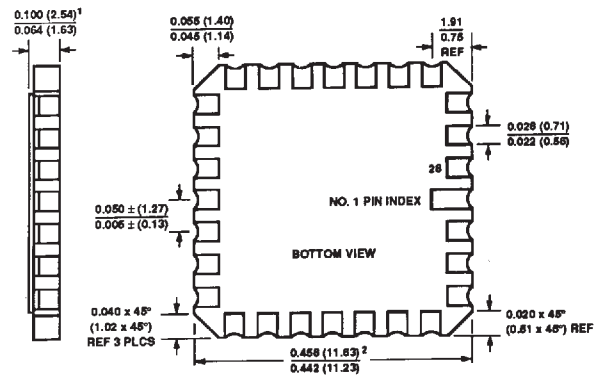

NOTES
1. THIS DIMENSION CONTROLS THE OVERALL PACKAGE THICKNESS.
2. APPLIES TO ALL FOUR SIDES.
3. ALL TERMINALS ARE GOLD PLATED.

Looking for pricing, stock, or lifecycle information?

Click below to explore more details on WIN SOURCE:

 [View AD7535JN on WIN SOURCE](#)

 [Analog Devices Inc. Information](#)

Optimize Your Supply Chain with WIN SOURCE Solutions

-  Global Sourcing Solution
-  Obsolete Management
-  Cost Control Management
-  Shortage Management
-  Alternative Solution
-  Excess Inventory Management