



**THE DATASHEET OF
SN65DP141RLJT**



SN65DP141 DisplayPort Linear Redriver

1 Features

- Supports VESA DisplayPort 1.4a, 2.0, and eDP 1.4
- Quad channel linear redriver supporting data rates up to 12 Gbps including DisplayPort RBR, HBR, HBR2, HBR3, and UHBR10
- Protocol agnostic
- Transparent to DP link training
- Position independent on the link suitable for source, sink, and cable applications
- 15-dB analog equalization at 6 GHz
- Output linear dynamic range: 1200 mV
- Bandwidth: >20 GHz
- Better than 16-dB return loss at 6 GHz
- 2.5-V or 3.3-V $\pm 5\%$ single power supply option
- Low power consumption with 80 mW per channel at 2.5 V V_{CC}
- GPIO or I²C control

2 Applications

- [Tablets](#)
- [Notebooks](#)
- [Desktops](#)
- [Docking stations](#)

3 Description

The SN65DP141 is an asynchronous, protocol-agnostic, low latency, four-channel linear equalizer optimized for use up to 12 Gbps and compensates for losses due to board traces and cables.

The device is transparent to DisplayPort (DP) link training such a way that a DP source and a sink can perform effective link training overcoming traditional *aux snooping* re-drivers' shortcomings. Additionally, the device is position independent. It can be placed inside source, cable or sink effectively providing a *negative loss* component to the overall link budget. Linear equalization inside SN65DP141 also increases link margin when used with a receiver implementing Decision Feedback Equalization (DFE).

SN65DP141 allows independent channel control for equalization, gain, dynamic range using both I²C and GPIO configurations.

Device Information⁽¹⁾

PART NUMBER	PACKAGE	BODY SIZE (NOM)
SN65DP141	WQFN (38)	7.00 mm × 5.00 mm

- (1) For all available packages, see the orderable addendum at the end of the data sheet.

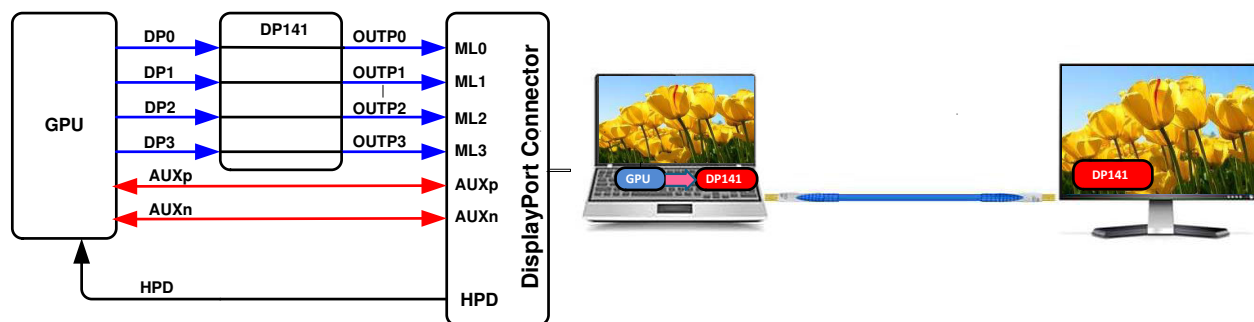

Copyright © 2016, Texas Instruments Incorporated

Simplified Schematic



Table of Contents

1 Features	1	8.3 Feature Description.....	15
2 Applications	1	8.4 Device Functional Modes.....	16
3 Description	1	8.5 Register Maps.....	17
4 Revision History	2	9 Application and Implementation	23
5 Pin Configuration and Functions	3	9.1 Application Information.....	23
6 Specifications	5	9.2 Typical Application.....	23
6.1 Absolute Maximum Ratings.....	5	10 Power Supply Recommendations	25
6.2 ESD Ratings.....	5	11 Layout	26
6.3 Recommended Operating Conditions.....	5	11.1 Layout Guidelines.....	26
6.4 Thermal Information.....	6	11.2 Layout Example.....	27
6.5 Electrical Characteristics.....	6	12 Device and Documentation Support	28
6.6 Switching Characteristics.....	7	12.1 Receiving Notification of Documentation Updates.....	28
6.7 Switching Characteristics, I ² C Interface.....	8	12.2 Support Resources.....	28
6.8 Typical Characteristics.....	9	12.3 Trademarks.....	28
7 Parameter Measurement Information	10	12.4 Electrostatic Discharge Caution.....	28
8 Detailed Description	14	12.5 Glossary.....	28
8.1 Overview.....	14	13 Mechanical, Packaging, and Orderable Information	28
8.2 Functional Block Diagram.....	14		

4 Revision History

NOTE: Page numbers for previous revisions may differ from page numbers in the current version.

Changes from Revision B (September 2021) to Revision C (December 2021)	Page
• Changed the I2C_EN pin Type from <i>internal pull-up</i> to <i>internal pull-down</i>	3
<hr/>	
Changes from Revision A (October 2016) to Revision B (September 2021)	Page
• Updated the numbering format for tables, figures, and cross-references throughout the document.....	1
• Updated the features from: Supports VESA DisplayPort 1.3, and eDP 1.4. to: Supports VESA DisplayPort 1.4a, 2.0, and eDP 1.4.....	1
• Updated the features from: including DisplayPort RBR, HBR, HBR2, and HBR3 to: including DisplayPort RBR, HBR, HBR2, HBR3, and UHBR10.....	1
• Updated the DP bit rates from: RBR to HBR3 (1.6 Gbps, 2.7 Gbps, 5.4 Gbps and 8.1 Gbps ... to: RBR to UHBR10 (1.6 Gbps, 2.7 Gbps, 5.4 Gbps, 8.1 Gbps and 10.0 Gbps ... in the <i>Overview</i> section.....	14
• Updated Operating data rate from HBR3 (8.1 Gbps) to UHBR10 (10 Gbps).....	23
<hr/>	
Changes from Revision * (February 2016) to Revision A (October 2016)	Page
• Replaced Figure 9-2	24

5 Pin Configuration and Functions

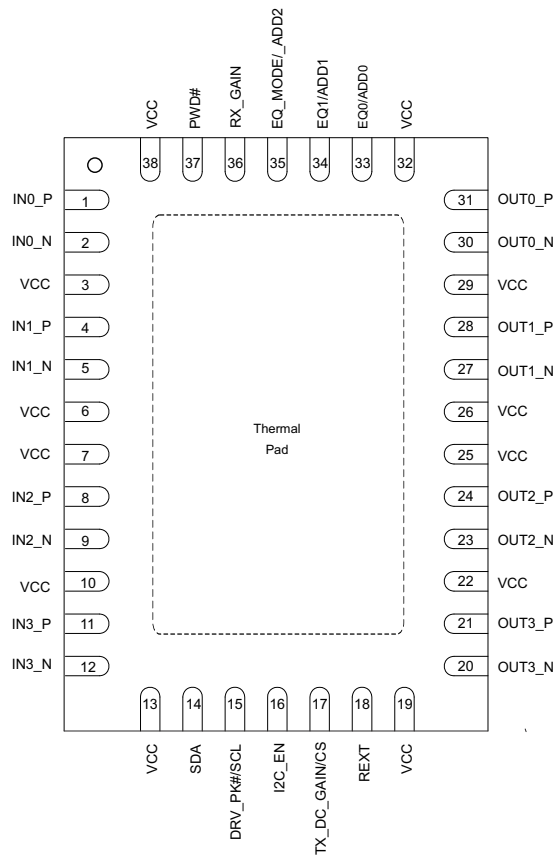

It is required for the thermal pad to be soldered to ground for better thermal performance.

Figure 5-1. RLJ Package 38 Pins (WQFN) Top View

Table 5-1. Pin Functions

PIN		TYPE ⁽¹⁾	DESCRIPTION
NAME	NO.		
DIFFERENTIAL HIGH-SPEED I/O			
IN0_P	1	I	Differential input, lane 0 (with 50 Ω termination to input common mode)
IN0_N	2	I	
IN1_P	4	I	Differential input, lane 1 (with 50 Ω termination to input common mode)
IN1_N	5	I	
IN2_P	8	I	Differential input, lane 2 (with 50 Ω termination to input common mode)
IN2_N	9	I	
IN3_P	11	I	Differential input, lane 3 (with 50 Ω termination to input common mode)
IN3_N	12	I	
OUT0_P	31	O	Differential output, lane 0
OUT0_N	30	O	
OUT1_P	28	O	Differential output, lane 1
OUT1_N	27	O	
OUT2_P	24	O	Differential output, lane 2
OUT2_N	23	O	
OUT3_P	21	O	Differential output, lane 3
OUT3_N	20	O	

Table 5-1. Pin Functions (continued)

PIN		TYPE ⁽¹⁾	DESCRIPTION	
NAME	NO.			
CONTROL SIGNALS				
DRV_PK#/SCL	15	I (with 200-k Ω internal pull-up)	GPIO mode: HIGH: disable Driver peaking LOW: enables Driver 6-dB AC peaking	I ² C mode: I ² C CLK. Connect a 10-k Ω pull-up resistor externally.
EQ_MODE/ ADD2	35	I (with 200-k Ω Internal pull-down, 2.5 V/3.3 V CMOS)	GPIO mode: HIGH: Trace mode LOW: Cable mode	I ² C mode: ADD2 along with pins ADD1 and ADD0 comprise the three bits of I ² C slave address. ADD2:ADD1:ADD0:XXX
EQ0/ADD0	33	I (2.5 V/3.3 V CMOS - 3-state)	GPIO mode: Working with RX_GAIN and EQ1 to determine the receiver DC and AC gain.	I ² C mode: ADD0 along with pins ADD1 and ADD2 comprise the three bits of I ² C slave address. ADD2:ADD1:ADD0:XXX
EQ1/ADD1	34	I (2.5 V/3.3 V CMOS - 3-state)	GPIO mode: Working with RX_GAIN and EQ0 to determine the receiver DC and AC gain.	I ² C mode: ADD1 along with pins ADD0 and ADD2 comprise the three bits of I ² C slave address ADD2:ADD1:ADD0:XXX
I2C_EN	16	I (with 200-k Ω internal pull-down)	Configures the device operation for I ² C or GPIO mode: HIGH: enables I2C mode LOW: enables GPIO mode	
PWD#	37	I (with 200-k Ω Internal pull-up, 2.5 V/3.3 V CMOS)	HIGH: Normal Operation LOW: Power downs the device, inputs off and outputs disabled, resets I ² C	
REXT	18	I (analog)	External Bias Resistor: 1,200 Ω to GND	
RX_GAIN	36	I (2.5 V/3.3 V CMOS - 3-state)	GPIO mode: Working with EQ0 and EQ1 to determine the receiver DC and AC gain.	I ² C mode: No action needed
SDA	14	I/O (open drain)	GPIO mode: No action needed.	I ² C mode: I ² C data. Connect a 10-k Ω pull-up resistor externally.
TX_DC_GAIN/CS	17	I (with 200-k Ω Internal pull-down, 2.5 V/3.3 V CMOS)	GPIO mode: HIGH: 6 dB DC gain for transmitter LOW: 0 dB DC gain for transmitter	I ² C mode: HIGH: acts as Chip Select LOW: disables I ² C interface
POWER SUPPLY				
GND Center Pad		Ground	The ground center pad is the metal contact at the bottom of the package. This pad must be connected to the GND plane. At least 15 PCB vias are recommended to minimize inductance and provide a solid ground. Refer to the package drawing (RLJ-package) for the via placement.	
VCC	3, 6, 7, 10, 13, 19, 22, 25, 26, 29, 32, 38	Power	Power supply 2.5 V \pm 5%, 3.3 V \pm 5%	

(1) I = input, O = output

6 Specifications

6.1 Absolute Maximum Ratings

over operating free-air temperature range (unless otherwise noted)^{(1) (2)}

		MIN	MAX	UNIT
Supply voltage range	VCC	-0.3	4	V
Differential voltage between INx_P and INx_N	VIN, DIFF	-2.5	2.5	V
Voltage at INx_P and INx_N,	VIN+, IN-	-0.5	V _{CC} + 0.5	V
Voltage on control IO pins, V _{IO}		-0.5	V _{CC} + 0.5	V
Continuous current at high speed differential data inputs(differential)	IN+, IN-	-25	25	mA
Continuous current at high speed differential data outputs	IOUT+, IOUT-	-25	25	mA

- (1) Stresses beyond those listed under *Absolute Maximum Ratings* may cause permanent damage to the device. These are stress ratings only, which do not imply functional operation of the device at these or any other conditions beyond those indicated under *Recommended Operating Conditions*. Exposure to absolute-maximum-rated conditions for extended periods may affect device reliability.
- (2) All voltage values, except differential I/O bus voltages, are with respect to network ground terminal.

6.2 ESD Ratings

		VALUE	UNIT
V _(ESD) Electrostatic discharge	Human-body model (HBM), per ANSI/ESDA/JEDEC JS-001 ⁽¹⁾	±2000	V
	Charged-device model (CDM), per JEDEC specification JESD22-C101 ⁽²⁾	±500	

- (1) JEDEC document JEP155 states that 500-V HBM allows safe manufacturing with a standard ESD control process.
- (2) JEDEC document JEP157 states that 250-V CDM allows safe manufacturing with a standard ESD control process.

6.3 Recommended Operating Conditions

over operating free-air temperature range (unless otherwise noted)

		MIN	NOM	MAX	UNIT
DR	Operating data rate			12	Gbps
V _{CC}	Supply voltage	2.375	2.5/3.3	3.465	V
T _C	Junction temperature	-10		125	°C
T _A	Operating free-air temperature	-40		85	°C
CMOS DC SPECIFICATIONS					
V _{IH}	Input high voltage	0.8 x V _{CC}			V
V _(MID)	Input middle voltage	V _{CC} x 0.4		V _{CC} x 0.6	V
V _{IL}	Input low voltage	-0.5		0.2 x V _{CC}	V

6.4 Thermal Information

THERMAL METRIC ⁽¹⁾		SN65DP141	UNIT
		RLJ (WQFN)	
		38 PINS	
R _{θJA}	Junction-to-ambient thermal resistance	36.9	°C/W
R _{θJC(top)}	Junction-to-case (top) thermal resistance	22.3	°C/W
R _{θJB}	Junction-to-board thermal resistance	10.7	°C/W
ψ _{JT}	Junction-to-top characterization parameter	0.3	°C/W
ψ _{JB}	Junction-to-board characterization parameter	10.6	°C/W
R _{θJC(bot)}	Junction-to-case (bottom) thermal resistance	1.9	°C/W

(1) For more information about traditional and new thermal metrics, see the *Semiconductor and IC Package Thermal Metrics* application report, [SPRA953](#).

6.5 Electrical Characteristics

over operating free-air temperature range (unless otherwise noted)

PARAMETER		TEST CONDITIONS	MIN	TYP	MAX	UNIT
POWER CONSUMPTION						
P _{DL}	Device Power dissipation	V _{OD} = Low, V _{CC} = 3.3 V and all 4 channels active		450	625	mW
		V _{OD} = Low, V _{CC} = 2.5 V and all 4 channels active		317	475	mW
P _{DH}	Device Power dissipation	V _{OD} = High, V _{CC} = 3.3 V and all 4 channels active		697	925	mW
		V _{OD} = High, V _{CC} = 2.5 V and all 4 channels active		485	675	mW
P _{DOFF}	Device power with all 4 channels switched off	Refer to I2C section for device configuration		10		mW
CMOS DC SPECIFICATIONS						
I _{IH}	High level input current	V _{IN} = 0.9 × V _{CC}	-40	17	40	μA
I _{IL}	Low level input current	V _{IN} = 0.1 × V _{CC}	-40	17	40	μA
CML INPUTS (IN[3:0]_P, IN[3:0]_N)						
R _{IN}	Differential input resistance	INx_P to INx_N		100		Ω
V _{IN}	Input linear dynamic range	Gain = 0.5		1200		mVpp
V _{ICM}	Input common mode voltage	Internally biased		V _{CC} – 0.8		V
SCD11	Input differential to common mode conversion	100 MHz to 6 GHz		-20		dB
SDD11	Differential input return loss	100 MHz to 6 GHz		-15		dB
CML OUTPUTS (OUT[3:0]_P, OUT[3:0]_N)						
V _{OD}	Output linear dynamic range	R _L = 100 Ω, V _{OD} = HIGH		1200		mVpp
		R _L = 100 Ω, V _{OD} = LOW		600		mVpp
V _{OS}	Output offset voltage	R _L = 100 Ω, 0 V applied at inputs		10		mVpp
V _{OCM}	Output common mode voltage			V _{CC} – 0.4		V
V _{CM(RIP)}	Common mode output ripple	K28.5 pattern at 12 Gbps on all 4 channels, No interconnect loss, V _{OD} = HIGH		10	20	mVRMS
V _{OD(RIP)}	Differential path output ripple	K28.5 pattern at 12 Gbps on all channels, No interconnect loss, V _{IN} = 1200 mVpp.			20	mVpp
V _{OC(SS)}	Change in steady-state common mode output voltage between logic states			±10		mV

6.6 Switching Characteristics

over operating free-air temperature range (unless otherwise noted)

PARAMETER		TEST CONDITIONS	MIN	TYP	MAX	UNIT
CML OUTPUTS (OUT[3:0]_P, OUT[3:0]_N)						
t_R	Rise time ⁽¹⁾	Input signal with 30 ps rise time, 20% to 80%, See Figure 7-3		31		ps
t_F	Fall time ⁽¹⁾	Input signal with 30 ps fall time, 20% to 80%, See Figure 7-3		32		ps
SDD22	Differential output return loss	6 GHz (12 Gbps)		-14		dB
		4.05 GHz (HBR3, 8.1 Gbps)		-9.33		dB
		4.05 GHz (HBR3, 8.1 Gbps)		-6.35		dB
		1.35 GHz (HBR, 2.7Gbps)		-3.5		dB
t_{PLH}	Low-to-high propagation delay	See Figure 7-2		65		ps
t_{PHL}	High-to-low propagation delay			65		ps
$t_{SK(O)}$	Inter-Pair (lane to lane) output skew ⁽²⁾	All outputs terminated with 100 Ω , See Figure 7-4		8		ps
$t_{SK(PP)}$	Part-to-part skew ⁽³⁾	All outputs terminated with 100 Ω			50	ps
r_{OT}	Single ended output resistance	Single ended on-chip termination to V_{CC} , Outputs are AC coupled		50		Ω
r_{OM}	Output termination mismatch at 1 MHz	$\Delta r_{OM} = 2 \times \left(\frac{r_p - r_m}{r_m + r_p} \right) \times 100$		5%		
	Channel-to-channel isolation		Frequency at 6 GHz	35	45	
	Output referred noise ⁽⁴⁾	10 MHz to 6 GHz, No other noise source present, $V_{OD} = \text{LOW}$		400		μVRMS
		10 MHz to 6 GHz, No other noise source present, $V_{OD} = \text{HIGH}$		500		μVRMS
EQUALIZATION						
G	At 6 GHz input signal	Equalization Gain, EQ = MAX		15		dB
$V_{(pre)}$	Output pre-cursor pre-emphasis	Input signal with 3.75 pre-cursor and measure it on the output signal, See Figure 7-5		3.75		dB
$V_{(pst)}$	Output post-cursor pre-emphasis	Input signal with 12 dB post-cursor and measure it on the output signal, See Figure 7-5		12		dB

- (1) Rise and Fall measurements include board and channel effects of the test environment, refer to [Figure 7-1](#) and [Figure 7-3](#).
- (2) $t_{SK(O)}$ is the magnitude of the time difference between the channels.
- (3) $t_{SK(PP)}$ is the magnitude of the difference in propagation delay times between any specified terminals of two devices when both devices operate with the same
- (4) All noise sources added.

6.7 Switching Characteristics, I²C Interface

over operating free-air temperature range (unless otherwise noted)

PARAMETER		MIN	TYP	MAX	UNIT
f _{SCL}	SCL clock frequency			400	KHz
t _{BUF}	Bus free time between START and STOP conditions	1.3			μs
t _{HDSTA}	"Hold time after repeated START condition. After this period, the first clock pulse is generated	0.6			μs
t _{LOW}	Low period of the SCL clock	1.3			μs
t _{HIGH}	High period of the SCL clock	0.6			μs
t _{SUSTA}	Setup time for a repeated START condition	0.6			μs
t _{HDDAT}	Data HOLD time	0			μs
t _{SUDAT}	Data setup time	100			μs
t _R	Rise time of both SDA and SCL signals			300	μs
t _F	Fall time of both SDA and SCL signals			300	μs
t _{SUSTO}	Setup time for STOP condition	0.6			μs

6.8 Typical Characteristics

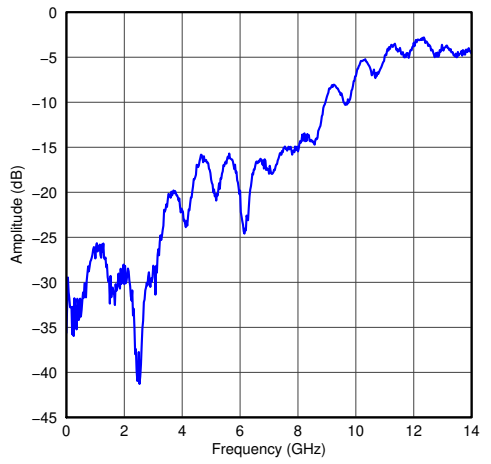

Figure 6-1. Differential Input Return Loss

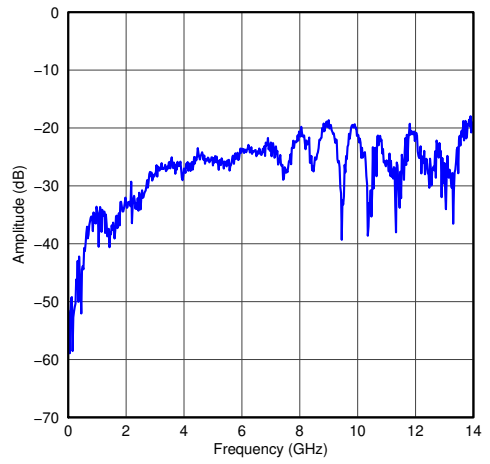

Figure 6-2. Differential to Common Mode Conversion

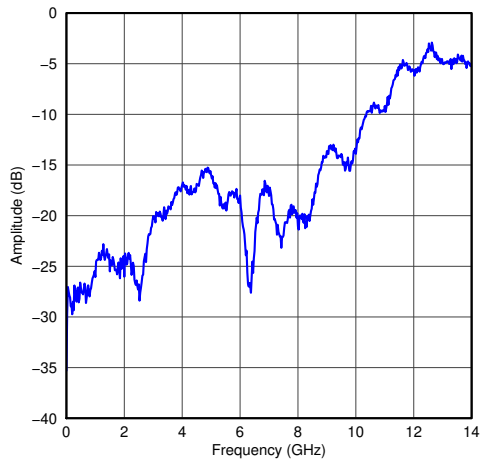

Figure 6-3. Differential Output Return Loss

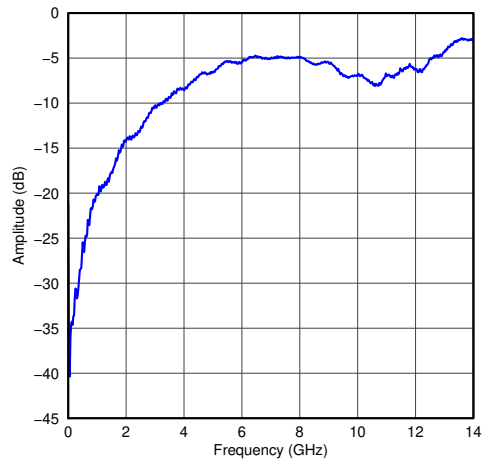
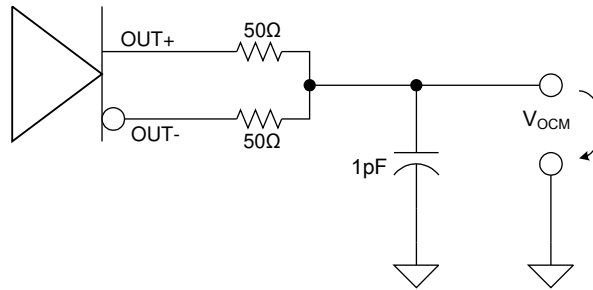

Figure 6-4. Common Mode Output Return Loss

7 Parameter Measurement Information



Copyright © 2016, Texas Instruments Incorporated

Figure 7-1. Common Mode Output Voltage Test Circuit

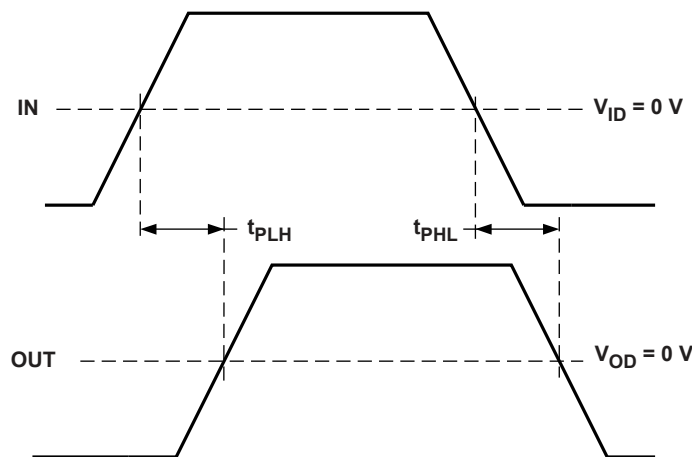

Figure 7-2. Propagation Delay Input to Output

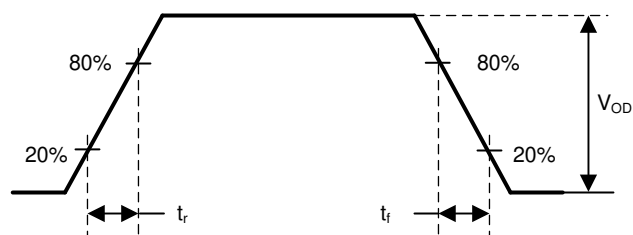

Figure 7-3. Output Rise and Fall Times

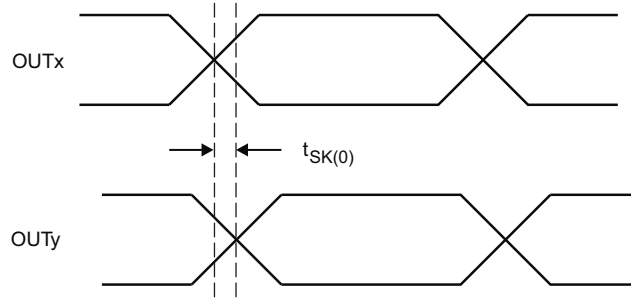

Figure 7-4. Output Inter-Pair Skew

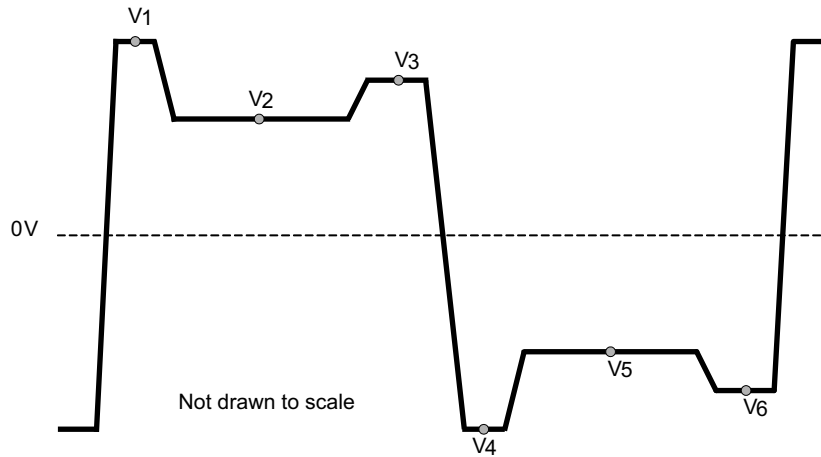

Figure 7-5. $V_{(pre)}$ and $V_{(post)}$ (test pattern is 1111111100000000 (8-1s, 8-0s))

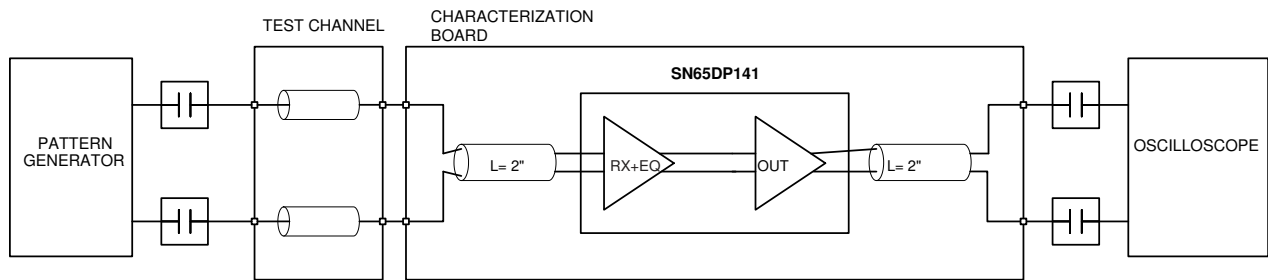

Figure 7-6. Receive Side Performance Test Circuit

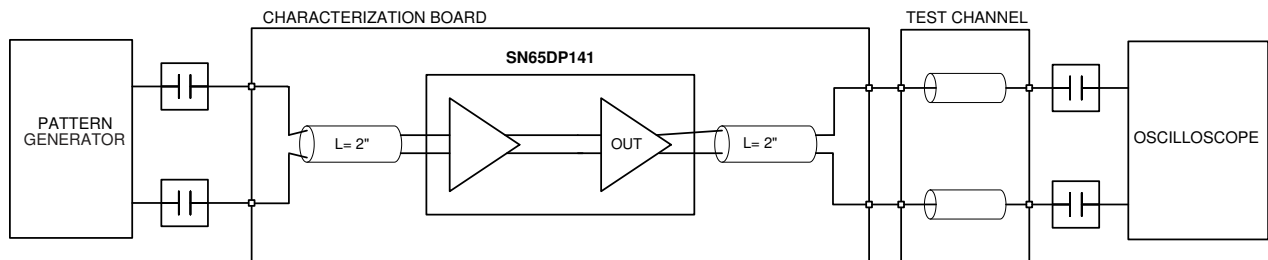
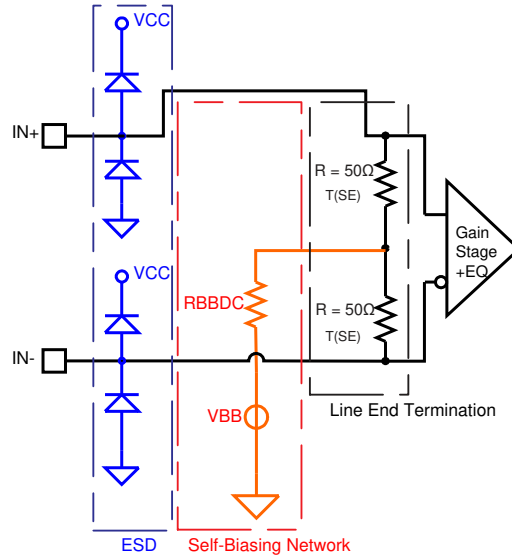
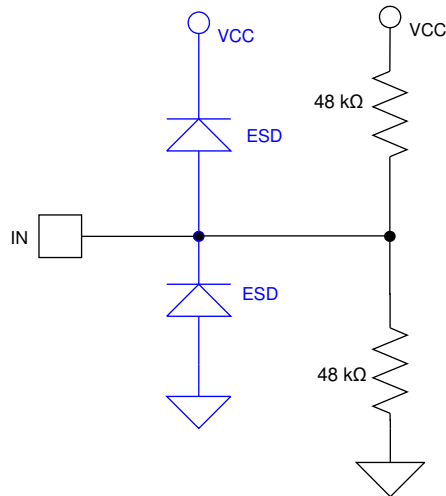

Figure 7-7. Transmit Side Performance Test Circuit



Copyright © 2016, Texas Instruments Incorporated

Figure 7-8. Equivalent Input Circuit



Copyright © 2016, Texas Instruments Incorporated

Figure 7-9. 3-Level Input Biasing Network

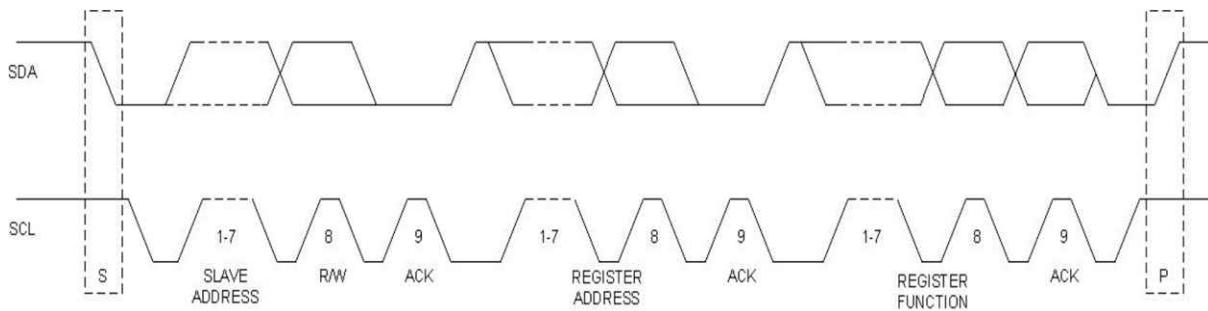

Figure 7-10. Two – Wire Serial Interface Data Transfer

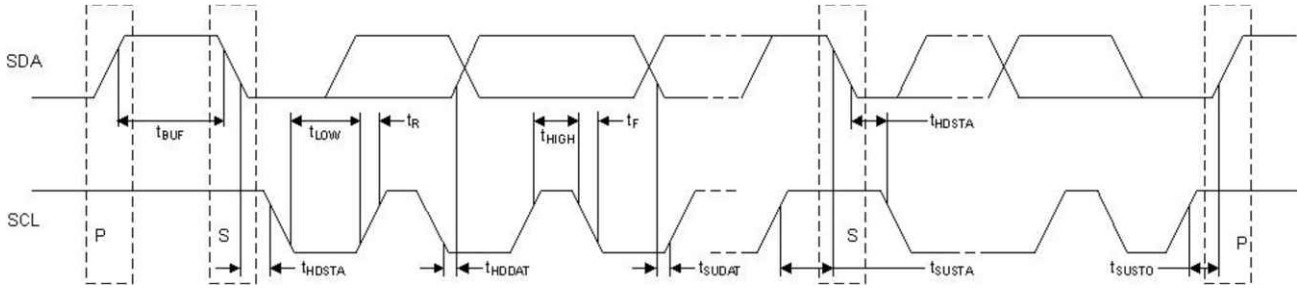

Figure 7-11. Two – Wire Serial Interface Timing Diagram

8 Detailed Description

8.1 Overview

The SN65DP141 is an asynchronous, protocol-agnostic, low latency, four-channel linear equalizer optimized for use up to 12 Gbps. The characteristics of this device make it transparent to DisplayPort (DP) link training. It supports all the available DP bit rates from RBR to UHBR10 (1.6 Gbps, 2.7 Gbps, 5.4 Gbps, 8.1 Gbps, and 10.0 Gbps respectively). Additionally, the SN65DP141 is configurable to a trace or cable mode, and hence improves its performance depending on the type of channel it is being used. Its transparency to the DP link training makes the SN65DP141 a position independent device, suitable for source/sink or cable applications, effectively providing a *negative loss* component to the overall link budget, in order to compensate the signal degradation over the channel.

The SN65DP141 is configurable by means of I²C and GPIOs, allowing independent channel control for activation, equalization, gain, and dynamic range.

8.2 Functional Block Diagram

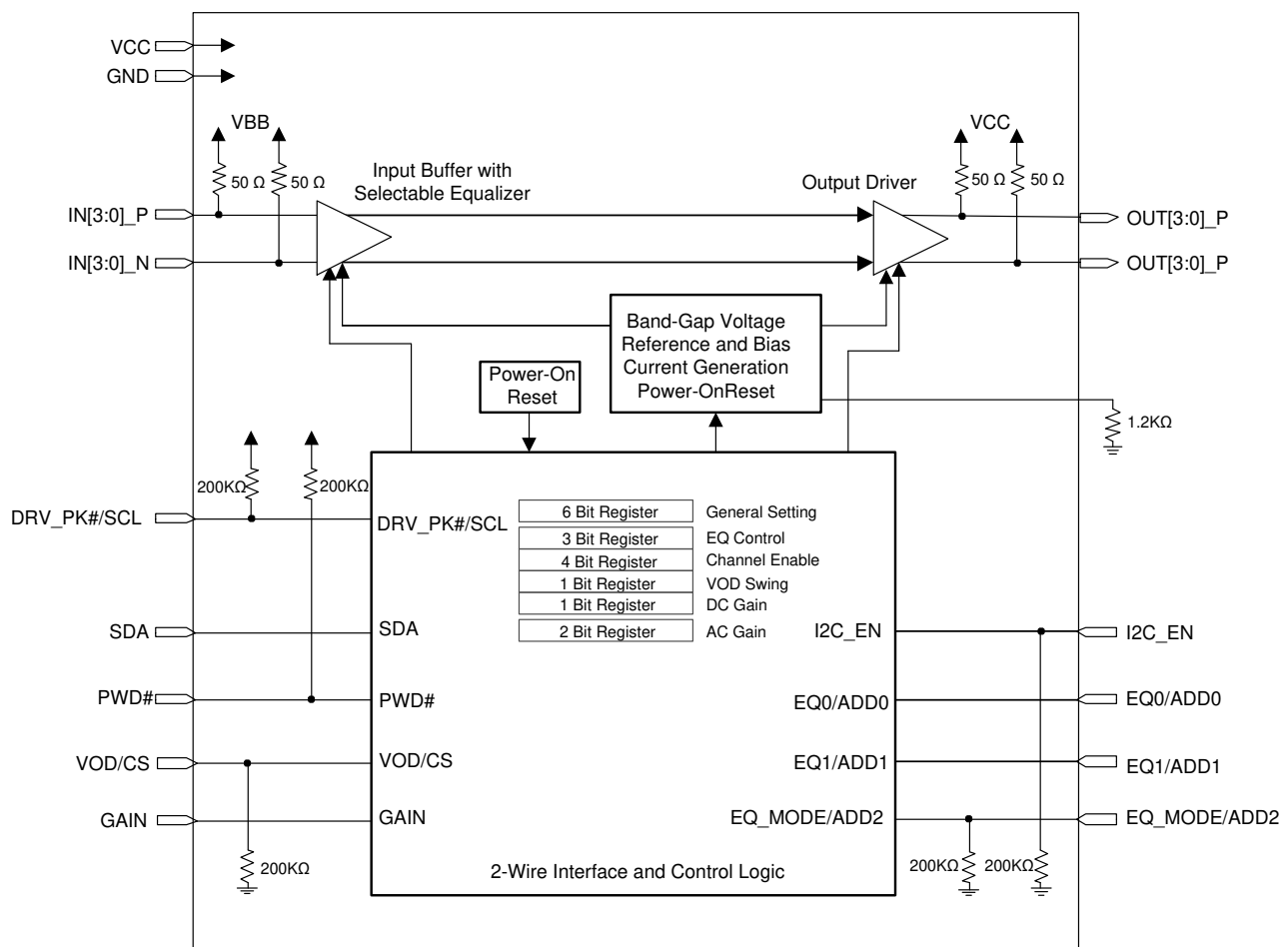

Copyright © 2016, Texas Instruments Incorporated

8.3 Feature Description

8.3.1 DC and AC Independent Gain Control

Besides the functional block diagram, the behavior of the SN65DP141 can be described as it is shown in [Figure 8-1](#); where the input stage first applies a DC gain (0 dB or –6 dB) and then equalizes the signal, which is driven to the output stage where the SN65DP141 applies an output DC gain (0 dB or 6 dB).

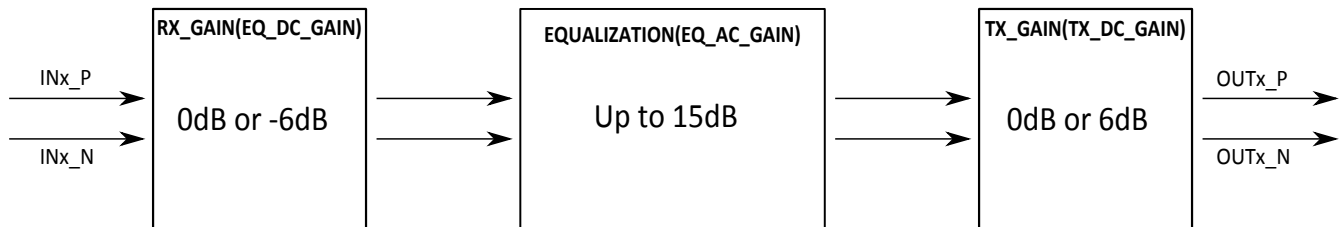

Figure 8-1. DP141 Signal Chain Gain Control

8.3.2 Two-Wire Serial Interface and Control Logic

The SN65DP141 uses a 2-wire serial interface for digital control. The two circuit inputs, SDA and SCL, are driven, respectively, by the serial data and serial clock from a microcontroller, for example. The SDA and SCK pins require external 10 kΩ pull-ups to VCC.

The 2-wire interface allows write access to the internal memory map to modify control registers and read access to read out control and status signals. The SN65DP141 is a slave device only which means that it cannot initiate a transmission itself; it always relies on the availability of the SCK signal for the duration of the transmission. The master device provides the clock signal as well as the START and STOP commands. The protocol for a data transmission is as follows:

1. START command
2. 7 bit slave address (0000ADD [2:0]) followed by an eighth bit which is the data direction bit (R/W). A zero indicates a WRITE and a 1 indicates a READ. The ADD [2:0] address bits change with the status of the ADD2, ADD1, and ADD0 device pins, respectively. If the pins are left floating or pulled down, the 7 bit slave address is 0000000.
3. 8-bit register address
4. 8-bit register data word
5. STOP command

Regarding timing, the SN65DP141 is I²C compatible. The typical timing is shown in [Figure 7-11](#) and a complete data transfer is shown in [Figure 7-10](#). Parameters for these figures are defined in the I²C Interface section of the [Switching Characteristics](#).

8.3.3 Bus Idle

Both SDA and SCL lines remain HIGH

8.3.4 Start Data Transfer

A change in the state of the SDA line, from HIGH to LOW, while the SCL line is HIGH, defines a START condition (S). Each data transfer is initiated with a START condition.

8.3.5 Stop Data Transfer

A change in the state of the SDA line from LOW to HIGH while the SCL line is HIGH defines a STOP condition (P). Each data transfer is terminated with a STOP condition; however, if the master still wishes to communicate on the bus, it can generate a repeated START condition and address another slave without first generating a STOP condition.

8.3.6 Data Transfer

The number of data bytes transferred between a START and a STOP condition is not limited and is determined by the master device. The receiver acknowledges the transfer of data.

8.3.7 Acknowledge

Each receiving device, when addressed, is obliged to generate an acknowledge bit. The transmitter releases the SDA line and a device that acknowledges must pull down the SDA line during the acknowledge clock pulse in such a way that the SDA line is stable LOW during the HIGH period of the acknowledge clock pulse. Setup and hold times must be taken into account. When a slave-receiver doesn't acknowledge the slave address, the data line must be left HIGH by the slave. The master can then generate a STOP condition to abort the transfer. If the slave-receiver does acknowledge the slave address but some time later in the transfer cannot receive any more data bytes, the master must abort the transfer. This is indicated by the slave generating the not acknowledge on the first byte to follow. The slave leaves the data line HIGH and the master generates the STOP condition.

8.4 Device Functional Modes

8.4.1 TRACE and CABLE Equalization Modes

The SN65DP141 is optimized for both trace and cable application at its input. The device pin EQ_MODE sets the EQ gain curve profile suitable for these two use cases.

8.4.2 Control Modes

The SN65DP141 features two control modes: GPIO and I2C, and the selection between these two modes is by means of the I2C_EN terminal, which activates the GPIO when tied to LOW; otherwise, the I2C mode is active due to its internal pull-up resistance.

8.4.3 GPIO MODE

Device Pins RX_GAIN, EQ1 and EQ0 determines receiver DC and AC gain as shown in [Table 8-1](#) and [Table 8-2](#).

Table 8-1. EQ Pin Settings

EQ1	EQ0	EQ Setting
GND	GND	000
GND	HiZ	000
GND	VCC	001
HiZ	GND	010
HiZ	HiZ	011
HiZ	VCC	100
VCC	GND	101
VCC	HiZ	110
VCC	VCC	111

Table 8-2. RX DC and AC GAIN Settings

EQ Configuration		EQ Gain	
EQ Setting	RX_GAIN	EQ_DC_GAIN (dB)	EQ_AC_GAIN (dB)
000 - 111	LOW	-6	1 - 9
000 - 111	HiZ	-6	7 - 17
000 - 111	HIGH	0	1 - 9

8.4.4 I²C Mode

Table 8-3. I2C Control Settings Description for RX DC and AC GAIN

EQ_MODE	EQ_DC GAIN	RX_GAIN<1:0>	EQ_Setting<2:0>	DC GAIN (dB)	AC GAIN (dB)	APPLICATION
0	0	00	000 to 111	-6	1 to 9	Short Input Cable; Large Input Swing
		11	000 to 111	-6	7 to 17	Long Input Cable; Large Input Swing
	1	01	000 to 111	0	1 to 9	Short Input Cable; Small Input Swing
		11	000 to 111	0	2 to 10	Short Input Cable; Small Input Swing
1	0	00	000 to 111	-6	1 to 9	Short Input Trace; Large Input Swing
		11	000 to 111	-6	7 to 17	Long Input Trace; Large Input Swing
	1	01	000 to 111	0	1 to 9	Short Input Trace; Small Input Swing
		11	000 to 111	0	2 to 10	Short Input Trace; Small Input Swing

8.5 Register Maps

8.5.1 Register 0x00 (General Device Settings) (offset = 00000000) [reset = 00000000]

Figure 8-2. Register 0x00 (General Device Settings)

7	6	5	4	3	2	1	0
SW_GPIO	PWRDOWN	SYNC_01	SYNC_23	SYNC_ALL	EQ_MODE		RSVD
R/W	R/W	R/W	R/W	R/W	R/W	R/W	R/W

LEGEND: R/W = Read/Write; R = Read only; -n = value after reset

Table 8-4. Register 0x00 (General Device Settings)

Bit	Field	Type	Reset	Description
7	SW_GPIO	R/W	0	Switching logic is controlled by GPIO or I2C: 0 = I2C control 1 = GPIO control
6	PWRDOWN	R/W	0	Power down the device: 0 = Normal operation 1 = Powerdown
5	SYNC_01	R/W	0	All settings from channel 1 will be used for channel 0 and 1: 0 = Channel 0 tracking channel 1 settings 1 = No tracking tracking
4	SYNC_23	R/W	0	All settings from channel 2 will be used for channel 2 and 3: 0 = Channel 3 tracking channel 2 settings 1 = No channel tracking
3	SYNC_ALL	R/W	0	All settings from channel 1 will be used on all channels: 0 = All channels tracking channel 1 1 = No channel tracking Overwrites SYNC_01 and SYNC_23
2	EQ_MODE	R/W	0	Set EQ mode: 0 = Cable mode 1 = Trace mode
1		R/W	0	
0	RSVD	R/W	0	For TI use only

8.5.2 Register 0x01 (Channel Enable) (offset = 00000000) [reset = 00000000]

Figure 8-3. Register 0x01 (Channel Enable)

7	6	5	4	3	2	1	0
				LN_EN_CH3	LN_EN_CH2	LN_EN_CH1	LN_EN_CH0
R	R	R	R	R/W	R/W	R/W	R/W

LEGEND: R/W = Read/Write; R = Read only; -n = value after reset

Table 8-5. Register 0x01 (Channel Enable)

Bit	Field	Type	Reset	Description
7		R	0	
6		R	0	
5		R	0	
4		R	0	
3	LN_EN_CH3	R/W	0	Channel 3 enable: 0 = Enable 1 = Disable
2	LN_EN_CH2	R/W	0	Channel 2 enable: 0 = Enable 1 = Disable
1	LN_EN_CH1	R/W	0	Channel 1 enable: 0 = Enable 1 = Disable
0	LN_EN_CH0	R/W	0	Channel 0 enable: 0 = Enable 1 = Disable

8.5.3 Register 0x02 (Channel 0 Control Settings) (offset = 00000000) [reset = 00000000]

Figure 8-4. Register 0x02 (Channel 0 Control Settings)

7	6	5	4	3	2	1	0
RSVD	EQ Setting<2>	EQ Setting<1>	EQ Setting<0>	TX_GAIN	EQ_DC_GAIN	RX_GAIN<1>	RX_GAIN<0>
R/W	R/W	R/W	R/W	R/W	R/W	R/W	R/W

LEGEND: R/W = Read/Write; R = Read only; -n = value after reset

Table 8-6. Register 0x02 (Channel 0 Control Settings)

Bit	Field	Type	Reset	Description
7	RSVD	R/W	0	
6	EQ Setting<2>	R/W	0	Equalizer adjustment setting: 000 = Minimum equalization setting 111 = Maximum equalization setting
5	EQ Setting<1>	R/W	0	
4	EQ Setting<0>	R/W	0	
3	TX_GAIN	R/W	0	Channel [0] TX_DC_GAIN control: 0 = Set 0 dB DC gain for transmitter 1 = Set 6 dB DC gain for transmitter
2	EQ_DC_GAIN	R/W	0	Channel [0] EQ DC gain: 0 = Set EQ DC gain to -6 dB 1 = Set EQ DC gain to -0 dB
1	RX_GAIN<1>	R/W	0	Equivalent to RX_GAIN control pin for channel [0]. 00: RX_GAIN = Low 01: RX_GAIN = HiZ 11: RX_GAIN = High
0	RX_GAIN<0>	R/W	0	

8.5.4 Register 0x03 (Channel 0 Enable Settings) (offset = 00000000) [reset = 00000000]

Figure 8-5. Register 0x03 (Channel 0 Enable Settings)

7	6	5	4	3	2	1	0
					DRV_PEAK	EQ_EN	DRV_EN
R	R	R	R	R	R/W	R/W	R/W

LEGEND: R/W = Read/Write; R = Read only; -n = value after reset

Table 8-7. Register 0x03 (Channel 0 Enable Settings)

Bit	Field	Type	Reset	Description
7		R	0	
6		R	0	
5		R	0	
4		R	0	
3		R	0	
2	DRV_PEAK	R/W	0	Channel [0] driver peaking: 0 = Disables driver Peaking 1 = Enables driver 6 db AC Peaking"
1	EQ_EN	R/W	0	Channel [0] EQ stage enable: 0 = Enable 1 = Disable
0	RSVDRV_EN	R/W	0	Channel [0] driver stage enable: 0 = Enable 1 = Disable

8.5.5 Register 0x05 (Channel 1 Control Settings) (offset = 00000000) [reset = 00000000]

Figure 8-6. Register 0x05 (Channel 1 Control Settings)

7	6	5	4	3	2	1	0
RSVD	EQ Setting<2>	EQ Setting<1>	EQ Setting<0>	TX_GAIN	EQ_DC_GAIN	RX_GAIN<1>	RX_GAIN<0>
R/W	R/W	R/W	R/W	R/W	R/W	R/W	R/W

LEGEND: R/W = Read/Write; R = Read only; -n = value after reset

Table 8-8. Register 0x05 (Channel 1 Control Settings)

Bit	Field	Type	Reset	Description
7	RSVD	R/W	0	
6	EQ Setting<2>	R/W	0	Equalizer adjustment setting: 000 = Minimum equalization setting 111 = Maximum equalization setting
5	EQ Setting<1>	R/W	0	
4	EQ Setting<0>	R/W	0	
3	TX_GAIN	R/W	0	Channel [1] TX_DC_GAIN control: 0 = Set 0 dB DC gain for transmitter 1 = Set 6 dB DC gain for transmitter
2	EQ_DC_GAIN	R/W	0	Channel [1] EQ DC gain: 0 = Set EQ DC gain to -6 dB 1 = Set EQ DC gain to -0 dB
1	RX_GAIN<1>	R/W	0	Equivalent to RX_GAIN control pin for channel [1]. 00: RX_GAIN = Low 01: RX_GAIN = HiZ 11: RX_GAIN = High
0	RX_GAIN<0>	R/W	0	

8.5.6 Register 0x06 (Channel 1 Enable Settings) (offset = 00000000) [reset = 00000000]

Figure 8-7. Register 0x06 (Channel 1 Enable Settings)

7	6	5	4	3	2	1	0
					DRV_PEAK	EQ_EN	DRV_EN
R	R	R	R	R	R/W	R/W	R/W

LEGEND: R/W = Read/Write; R = Read only; -n = value after reset

Table 8-9. Register 0x06 (Channel 1 Enable Settings)

Bit	Field	Type	Reset	Description
7		R	0	
6		R	0	
5		R	0	
4		R	0	
3		R	0	
2	DRV_PEAK	R/W	0	Channel [1] driver peaking: 0 = Disables driver Peaking 1 = Enables driver 6 db AC Peaking
1	EQ_EN	R/W	0	Channel [1] EQ stage enable: 0 = Enable 1 = Disable
0	DRV_EN	R/W	0	Channel [1] driver stage enable: 0 = Enable 1 = Disable

8.5.7 Register 0x08 (Channel 2 Control Settings) (offset = 00000000) [reset = 00000000]

Figure 8-8. Register 0x08 (Channel 2 Control Settings)

7	6	5	4	3	2	1	0
RSVD	EQ Setting<2>	EQ Setting<1>	EQ Setting<0>	TX_GAIN	EQ_DC_GAIN	RX_GAIN<1>	RX_GAIN<0>
R/W	R/W	R/W	R/W	R/W	R/W	R/W	R/W

LEGEND: R/W = Read/Write; R = Read only; -n = value after reset

Table 8-10. Register 0x08 (Channel 2 Control Settings)

Bit	Field	Type	Reset	Description
7	RSVD	R/W	0	
6	EQ Setting<2>	R/W	0	Equalizer adjustment setting: 000 = Minimum equalization setting 111 = Maximum equalization setting
5	EQ Setting<1>	R/W	0	
4	EQ Setting<0>	R/W	0	
3	TX_GAIN	R/W	0	Channel [2] TX_DC_GAIN control: 0 = Set 0 dB DC gain for transmitter 1 = Set 6 dB DC gain for transmitter
2	EQ_DC_GAIN	R/W	0	Channel [2] EQ DC gain: 0 = Set EQ DC gain to -6 dB 1 = Set EQ DC gain to -0 dB
1	RX_GAIN<1>	R/W	0	Equivalent to RX_GAIN control pin for channel [2]. 00: RX_GAIN = Low 01: RX_GAIN = HiZ 11: RX_GAIN = High
0	RX_GAIN<0>	R/W	0	

8.5.8 Register 0x09 (Channel 2 Enable Settings) (offset = 00000000) [reset = 00000000]

Figure 8-9. Register 0x09 (Channel 2 Enable Settings)

7	6	5	4	3	2	1	0
					DRV_PEAK	EQ_EN	DRV_EN
R	R	R	R	R	R/W	R/W	R/W

LEGEND: R/W = Read/Write; R = Read only; -n = value after reset

Table 8-11. Register 0x09 (Channel 2 Enable Settings)

Bit	Field	Type	Reset	Description
7		R	0	
6		R	0	
5		R	0	
4		R	0	
3		R	0	
2	DRV_PEAK	R/W	0	Channel [2] driver peaking: 0 = Disables driver Peaking 1 = Enables driver 6 db AC Peaking
1	EQ_EN	R/W	0	Channel [2] driver stage enable: 0 = Enable 1 = Disable
0	DRV_EN	R/W	0	Channel [2] driver stage enable: 0 = Enable 1 = Disable

8.5.9 Register 0x0B (Channel 3 Control Settings) (offset = 00000000) [reset = 00000000]

Figure 8-10. Register 0x0B (Channel 3 Control Settings)

7	6	5	4	3	2	1	0
RSVD	EQ Setting<2>	EQ Setting<1>	EQ Setting<0>	TX_GAIN	EQ_DC_GAIN	RX_GAIN<1>	RX_GAIN<0>
R/W	R/W	R/W	R/W	R/W	R/W	R/W	R/W

LEGEND: R/W = Read/Write; R = Read only; -n = value after reset

Table 8-12. Register 0x0B (Channel 3 Control Settings)

Bit	Field	Type	Reset	Description
7	RSVD	R/W	0	
6	EQ Setting<2>	R/W	0	Equalizer adjustment setting: 000 = Minimum equalization setting 111 = Maximum equalization setting
5	EQ Setting<1>	R/W	0	
4	EQ Setting<0>	R/W	0	
3	TX_GAIN	R/W	0	Channel [3] TX_DC_GAIN control: 0 = Set 0 dB DC gain for transmitter 1 = Set 6 dB DC gain for transmitter
2	EQ_DC_GAIN	R/W	0	Channel [3] EQ DC gain: 0 = Set EQ DC gain to -6 dB 1 = Set EQ DC gain to -0 dB
1	RX_GAIN<1>	R/W	0	Equivalent to RX_GAIN control pin for channel [3]. 00: RX_GAIN = Low 01: RX_GAIN = HiZ 11: RX_GAIN = High
0	RX_GAIN<0>	R/W	0	

8.5.10 Register 0x0C (Channel 3 Control Settings) (offset = 00000000) [reset = 00000000]

Figure 8-11. Register 0x0C (Channel 3 Enable Settings)

7	6	5	4	3	2	1	0
					DRV_PEAK	EQ_EN	DRV_EN
R	R	R	R	R	R/W	R/W	R/W

LEGEND: R/W = Read/Write; R = Read only; -n = value after reset

Table 8-13. Register 0x0C (Channel 3 Enable Settings)

Bit	Field	Type	Reset	Description
7		R	0	
6		R	0	
5		R	0	
4		R	0	
3		R	0	
2	DRV_PEAK	R/W	0	Channel [3] driver peaking: 0 = Disables driver Peaking 1 = Enables driver 6db AC Peaking
1	EQ_EN	R/W	0	Channel [3] EQ stage enable: 0 = Enable 1 = Disable
0	RSVDRV_EN	R/W	0	Channel [3] driver stage enable: 0 = Enable 1 = Disable

9 Application and Implementation

Note

Information in the following applications sections is not part of the TI component specification, and TI does not warrant its accuracy or completeness. TI's customers are responsible for determining suitability of components for their purposes, as well as validating and testing their design implementation to confirm system functionality.

9.1 Application Information

The SN65DP141 can be used in Source, Sink, cable, and dongle applications, where the device is transparent to the DisplayPort link layer. For illustrating purposes, this section shows the implementation of a DisplayPort dongle, [Figure 9-1](#) shows an example of the SN65DP141 on a dongle board, where the AUX channel is directly connected from source to sink, meanwhile the power can be provided either way from the DP source or an external power source.

9.2 Typical Application

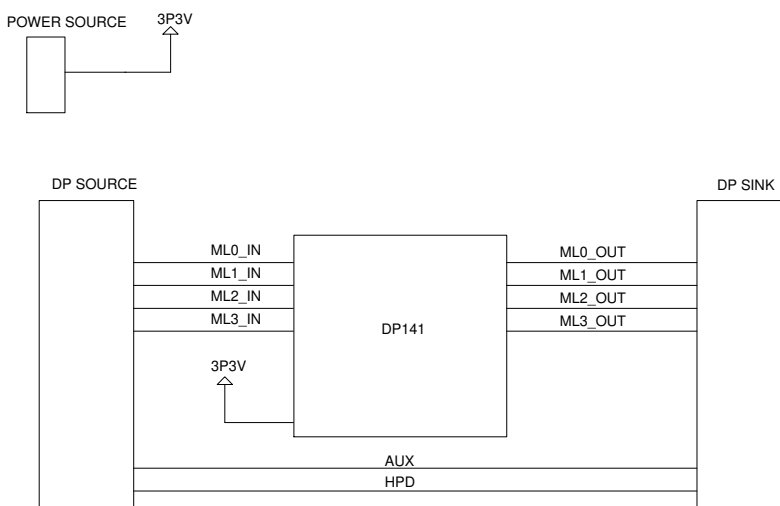

Copyright © 2016, Texas Instruments Incorporated

Figure 9-1. SN65DP141 Application Diagram

9.2.1 Design Requirements

The SN65DP141 can be designed into many types of applications. All applications have certain requirements for the system to work properly. The voltage rails are required to support the lowest possible power consumption. Configure the device by using I2C. The GPIO configuration is provided as I²C is not available in all cases. Because sources may have different naming conventions, confirm the link between source and sink is correctly mapped through the SN65DP141.

Table 9-1. Design Parameters

PARAMETER	VALUE
Operating data rate	UHBR10 (10 Gbps)
Supply voltage	3.3 V
Main link input voltage	$V_{ID} = 75 \text{ mVpp}$ to 1.2 Vpp
Control pin Low	1 K Ω pulled to GND
Control pin Mid	No Connect
Control pin High	1 K Ω pulled to High
Main link AC decoupling capacitor	75 to 200 nF, recommend 100 nF

SN65DP141

SNLSE6C – FEBRUARY 2016 – REVISED DECEMBER 2021

First approach for GAIN configuration: It is highly recommend that DC GAIN be set to 1, this leads the output to preserve the input amplitude (GAIN = 1):

- For GPIO implementation: Use a pull-up resistor on the GAIN terminal (pin 36), refer to the schematic in [Figure 9-2](#).
- For I²C implementation: write a 1 to the bit 2 of the registers 0x02, 0x05, 0x08 and 0x0B. Refer to [Section 8.3.2](#) for a detailed description of the I²C interface

9.2.2 Detailed Design Procedure

Designing in the SN65DP141 requires the following:

- Determine the loss profile on the DP input and output channels and cables.
- Based upon the loss profile and signal swing, determine the optimal configuration for the SN65DP141, to pass electrical compliance (Equalization mode, EQ Gain, DC gain, and AC Gain).
- See [Figure 9-2](#) for information on using the AC coupling capacitors and control pin resistors, as well as for recommended decouple capacitors from VCC pins to ground.
- Configure the TheSN65DP141 using the GPIO terminals or the I²C interface:
 - GPIO – Using the terminals EQ_MODE, EQ1, EQ1, and gain.
 - I²C – Refer to the I2C [Register Maps](#) and the [Two-Wire Serial Interface and Control Logic](#) sections for a detailed configuration procedures.
- The thermal pad must be connected to ground.

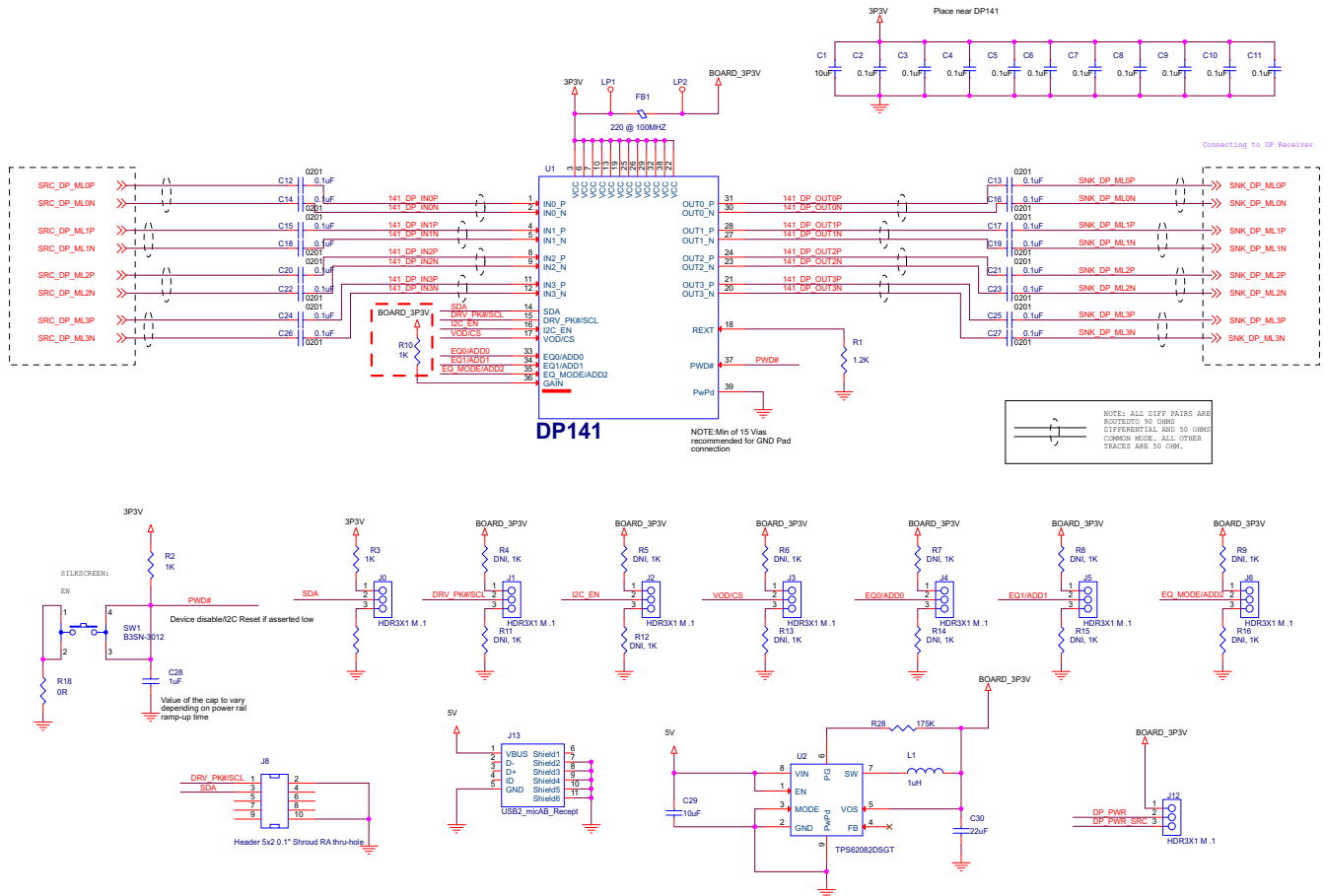
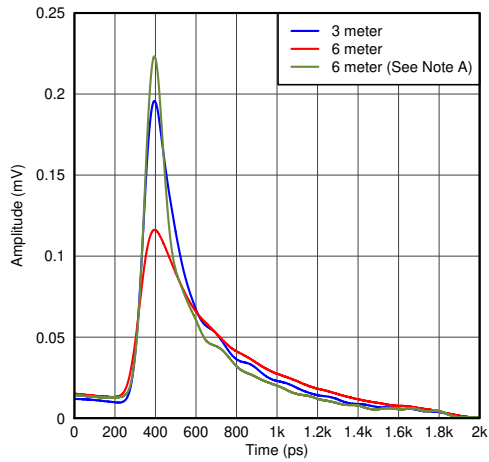

Figure 9-2. SN65DP141 Application Schematic

9.2.3 Application Curves



With SN65DP141 -> EQ = 4, VOD = High, ACGain = HiZ, DCGain = Low

Figure 9-3. Cable Mode – Symbol Response

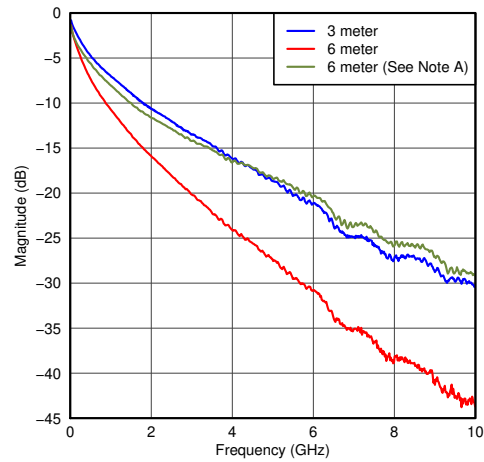

With SN65DP141 -> EQ = 4, VOD = High, ACGain = HiZ, DCGain = Low

Figure 9-4. Cable Mode – Frequency Domain

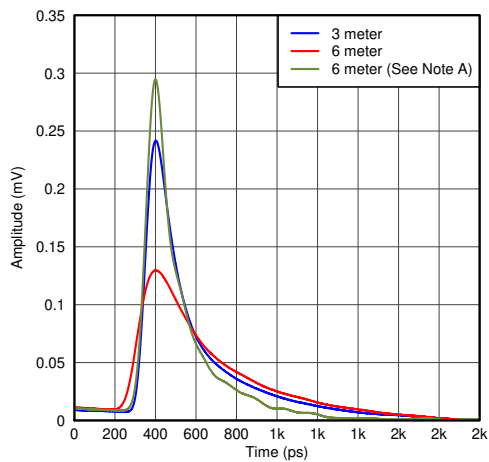

With SN65DP141 -> EQ = 7, VOD = High, ACGain = High, DCGain = Low

Figure 9-5. Trace Mode – Symbol Response

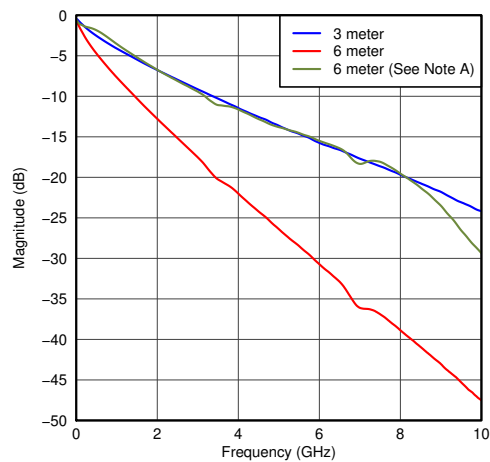

With SN65DP141 -> EQ = 7, VOD = High, ACGain = High, DCGain = Low

Figure 9-6. Trace Mode – Frequency Domain

10 Power Supply Recommendations

To minimize the power supply noise floor, provide good decoupling near the SN65DP141 power pins. It is recommended to place one 0.01- μ F ceramic capacitor at each power pin, and two 0.1- μ F ceramic capacitors on each power node. The distance between the SN65DP141 and capacitors should be minimized to reduce loop inductance and provide optimal noise filtering. Placing the capacitor underneath the SN65DP141 on the bottom of the PCB is often a good choice. A 100-pF ceramic capacitor can be put at each power pin to optimize the EMI performance.

11 Layout

11.1 Layout Guidelines

- Placing a solid ground plane next to the high-speed signal layer establishes controlled impedance for transmission line interconnects and provides an excellent low-inductance path for the return current flow.
- Placing the power plane next to the ground plane creates additional high-frequency bypass capacitance.
- Routing the slower speed control signals on the bottom layer allows for greater flexibility as these signal links usually have margin to tolerate discontinuities such as vias.
- If an additional supply voltage plane or signal layer is needed, add a second power/ground plane system to the stack to keep it symmetrical. This makes the stack mechanically stable and prevents it from warping. Also the power and ground plane of each power system can be placed closer together, thus increasing the high frequency bypass capacitance significantly.
- The control pin pull-up and pull-down resistors are shown in application section for reference. If a high level is needed then only uses the pull up. If a low level is needed only use the pull down.
- Place passive components within the signal path, such as source-matching resistors or ac-coupling capacitors, next to each other. Routing as in case a) creates wider trace spacing than in b); the resulting discontinuity, however, is limited to a far narrower area.
- When routing traces next to a via or between an array of vias, make sure that the via clearance section does not interrupt the path of the return current on the ground plane below.
- Avoid metal layers and traces underneath or between the pads off the DisplayPort connectors for better impedance matching. Otherwise they will cause the differential impedance to drop below 75 Ω and fail the board during TDR testing.
- Use solid power and ground planes for 100 Ω impedance control and minimum power noise.
- For a multi-layer PCB, it is recommended to keep one common GND layer underneath the device and connect all ground terminals directly to this plane. For 100 Ω differential impedance, use the smallest trace spacing possible, which is usually specified by the PCB vendor.
- Keep the trace length as short as possible to minimize attenuation.
- Place bulk capacitors (that is, 10 μF) close to power sources, such as voltage regulators or where the power is supplied to the PCB.

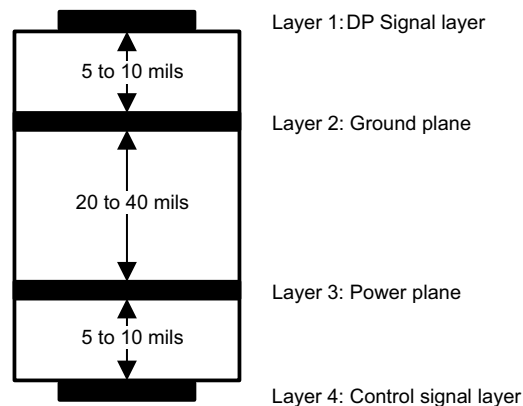

Figure 11-1. PCB Stack

11.2 Layout Example

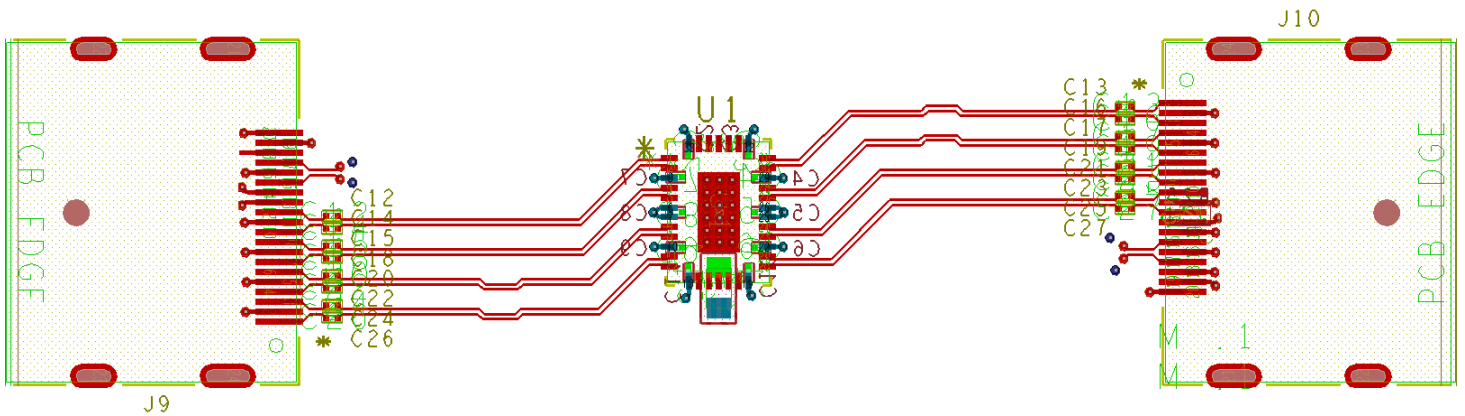

Figure 11-2. Example Layout (Top)

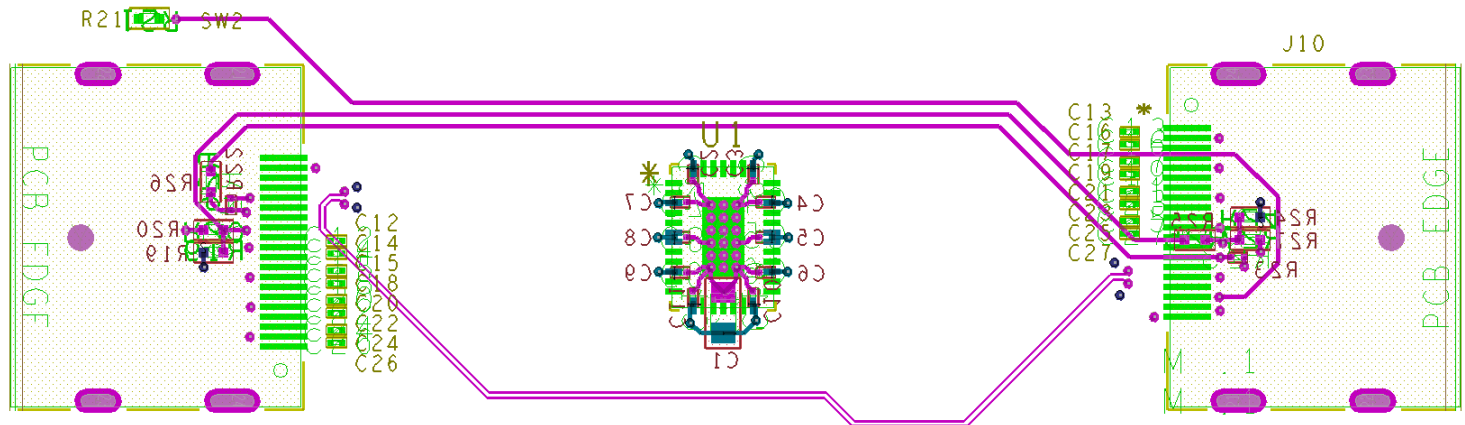

Figure 11-3. Example Layout (Top)

12 Device and Documentation Support

12.1 Receiving Notification of Documentation Updates

To receive notification of documentation updates, navigate to the device product folder on ti.com. Click on *Subscribe to updates* to register and receive a weekly digest of any product information that has changed. For change details, review the revision history included in any revised document.

12.2 Support Resources

TI E2E™ [support forums](#) are an engineer's go-to source for fast, verified answers and design help — straight from the experts. Search existing answers or ask your own question to get the quick design help you need.

Linked content is provided "AS IS" by the respective contributors. They do not constitute TI specifications and do not necessarily reflect TI's views; see TI's [Terms of Use](#).

12.3 Trademarks

TI E2E™ is a trademark of Texas Instruments.

All trademarks are the property of their respective owners.

12.4 Electrostatic Discharge Caution



This integrated circuit can be damaged by ESD. Texas Instruments recommends that all integrated circuits be handled with appropriate precautions. Failure to observe proper handling and installation procedures can cause damage.

ESD damage can range from subtle performance degradation to complete device failure. Precision integrated circuits may be more susceptible to damage because very small parametric changes could cause the device not to meet its published specifications.



12.5 Glossary

[TI Glossary](#) This glossary lists and explains terms, acronyms, and definitions.

13 Mechanical, Packaging, and Orderable Information

The following pages include mechanical, packaging, and orderable information. This information is the most current data available for the designated devices. This data is subject to change without notice and revision of this document. For browser-based versions of this data sheet, refer to the left-hand navigation.

PACKAGING INFORMATION

Orderable Device	Status (1)	Package Type	Package Drawing	Pins	Package Qty	Eco Plan (2)	Lead finish/ Ball material (6)	MSL Peak Temp (3)	Op Temp (°C)	Device Marking (4/5)	Samples
SN65DP141RLJR	ACTIVE	WQFN	RLJ	38	3000	RoHS & Green	NIPDAU	Level-3-260C-168 HR	-40 to 85	DP141	
SN65DP141RLJT	ACTIVE	WQFN	RLJ	38	250	RoHS & Green	NIPDAU	Level-3-260C-168 HR	-40 to 85	DP141	

(1) The marketing status values are defined as follows:

ACTIVE: Product device recommended for new designs.

LIFEBUY: TI has announced that the device will be discontinued, and a lifetime-buy period is in effect.

NRND: Not recommended for new designs. Device is in production to support existing customers, but TI does not recommend using this part in a new design.

PREVIEW: Device has been announced but is not in production. Samples may or may not be available.

OBSOLETE: TI has discontinued the production of the device.

(2) **RoHS:** TI defines "RoHS" to mean semiconductor products that are compliant with the current EU RoHS requirements for all 10 RoHS substances, including the requirement that RoHS substance do not exceed 0.1% by weight in homogeneous materials. Where designed to be soldered at high temperatures, "RoHS" products are suitable for use in specified lead-free processes. TI may reference these types of products as "Pb-Free".

RoHS Exempt: TI defines "RoHS Exempt" to mean products that contain lead but are compliant with EU RoHS pursuant to a specific EU RoHS exemption.

Green: TI defines "Green" to mean the content of Chlorine (Cl) and Bromine (Br) based flame retardants meet JS709B low halogen requirements of <=1000ppm threshold. Antimony trioxide based flame retardants must also meet the <=1000ppm threshold requirement.

(3) MSL, Peak Temp. - The Moisture Sensitivity Level rating according to the JEDEC industry standard classifications, and peak solder temperature.

(4) There may be additional marking, which relates to the logo, the lot trace code information, or the environmental category on the device.

(5) Multiple Device Markings will be inside parentheses. Only one Device Marking contained in parentheses and separated by a "~" will appear on a device. If a line is indented then it is a continuation of the previous line and the two combined represent the entire Device Marking for that device.

(6) Lead finish/Ball material - Orderable Devices may have multiple material finish options. Finish options are separated by a vertical ruled line. Lead finish/Ball material values may wrap to two lines if the finish value exceeds the maximum column width.

Important Information and Disclaimer:The information provided on this page represents TI's knowledge and belief as of the date that it is provided. TI bases its knowledge and belief on information provided by third parties, and makes no representation or warranty as to the accuracy of such information. Efforts are underway to better integrate information from third parties. TI has taken and continues to take reasonable steps to provide representative and accurate information but may not have conducted destructive testing or chemical analysis on incoming materials and chemicals. TI and TI suppliers consider certain information to be proprietary, and thus CAS numbers and other limited information may not be available for release.

In no event shall TI's liability arising out of such information exceed the total purchase price of the TI part(s) at issue in this document sold by TI to Customer on an annual basis.

TAPE AND REEL INFORMATION

QUADRANT ASSIGNMENTS FOR PIN 1 ORIENTATION IN TAPE

*All dimensions are nominal

Device	Package Type	Package Drawing	Pins	SPQ	Reel Diameter (mm)	Reel Width W1 (mm)	A0 (mm)	B0 (mm)	K0 (mm)	P1 (mm)	W (mm)	Pin1 Quadrant
SN65DP141RLJR	WQFN	RLJ	38	3000	330.0	16.4	5.25	7.25	1.45	8.0	16.0	Q1
SN65DP141RLJT	WQFN	RLJ	38	250	330.0	16.4	5.25	7.25	1.45	8.0	16.0	Q1

TAPE AND REEL BOX DIMENSIONS

*All dimensions are nominal

Device	Package Type	Package Drawing	Pins	SPQ	Length (mm)	Width (mm)	Height (mm)
SN65DP141RLJR	WQFN	RLJ	38	3000	367.0	367.0	38.0
SN65DP141RLJT	WQFN	RLJ	38	250	367.0	367.0	38.0

RLJ (R-PWQFN-N38)

PLASTIC QUAD FLATPACK NO-LEAD

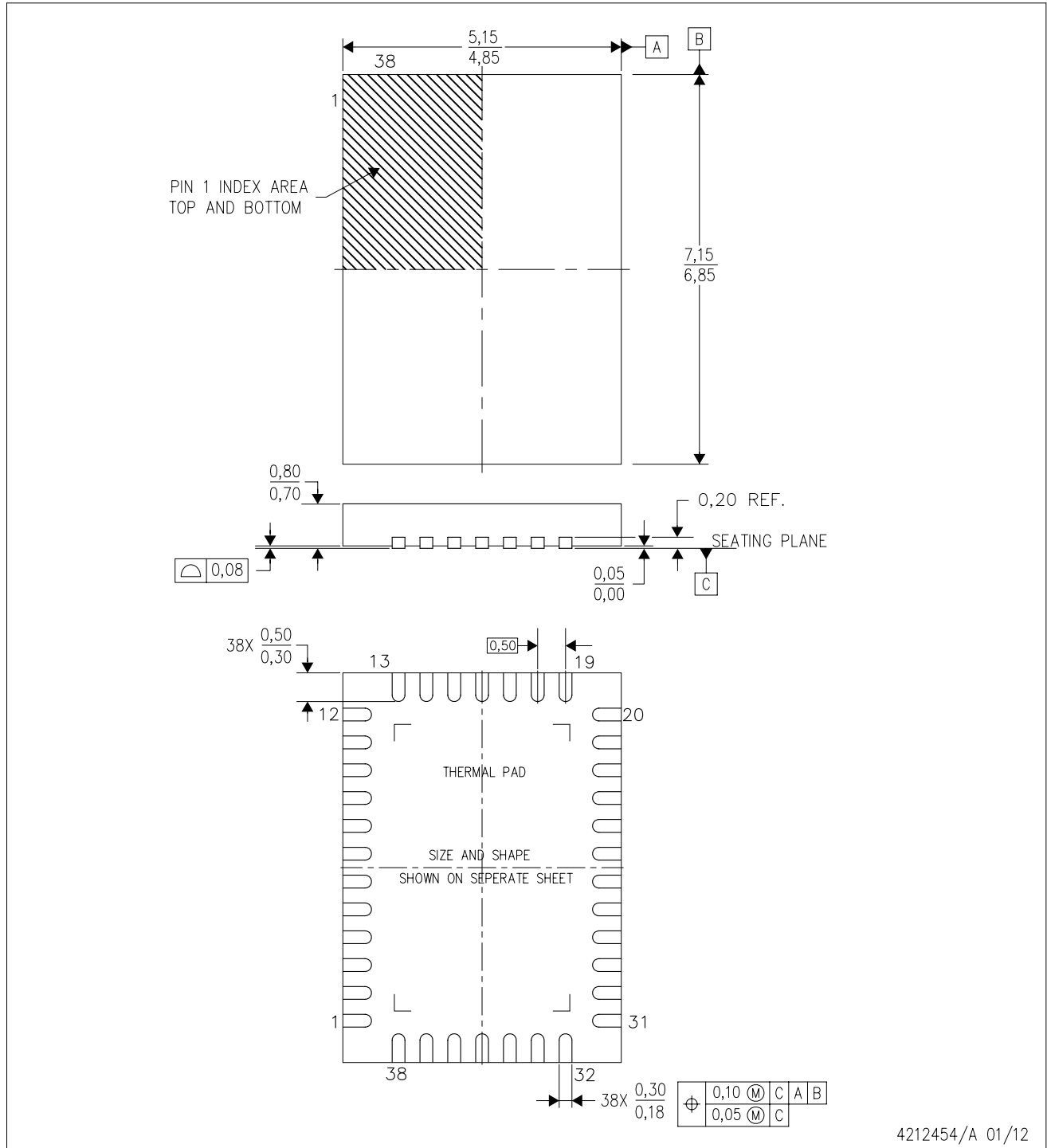

4212454/A 01/12

- NOTES:
- A. All linear dimensions are in millimeters. Dimensioning and tolerancing per ASME Y14.5-1994.
 - B. This drawing is subject to change without notice.
 - C. Quad Flatpack, No-leads (QFN) package configuration.
 - D. The package thermal pad must be soldered to the board for thermal and mechanical performance.
 - E. See the additional figure in the Product Data Sheet for details regarding the exposed thermal pad features and dimensions.
 - F. Falls within JEDEC MO-220.

IMPORTANT NOTICE AND DISCLAIMER

TI PROVIDES TECHNICAL AND RELIABILITY DATA (INCLUDING DATA SHEETS), DESIGN RESOURCES (INCLUDING REFERENCE DESIGNS), APPLICATION OR OTHER DESIGN ADVICE, WEB TOOLS, SAFETY INFORMATION, AND OTHER RESOURCES "AS IS" AND WITH ALL FAULTS, AND DISCLAIMS ALL WARRANTIES, EXPRESS AND IMPLIED, INCLUDING WITHOUT LIMITATION ANY IMPLIED WARRANTIES OF MERCHANTABILITY, FITNESS FOR A PARTICULAR PURPOSE OR NON-INFRINGEMENT OF THIRD PARTY INTELLECTUAL PROPERTY RIGHTS.

These resources are intended for skilled developers designing with TI products. You are solely responsible for (1) selecting the appropriate TI products for your application, (2) designing, validating and testing your application, and (3) ensuring your application meets applicable standards, and any other safety, security, regulatory or other requirements.

These resources are subject to change without notice. TI grants you permission to use these resources only for development of an application that uses the TI products described in the resource. Other reproduction and display of these resources is prohibited. No license is granted to any other TI intellectual property right or to any third party intellectual property right. TI disclaims responsibility for, and you will fully indemnify TI and its representatives against, any claims, damages, costs, losses, and liabilities arising out of your use of these resources.

TI's products are provided subject to [TI's Terms of Sale](#) or other applicable terms available either on ti.com or provided in conjunction with such TI products. TI's provision of these resources does not expand or otherwise alter TI's applicable warranties or warranty disclaimers for TI products.

TI objects to and rejects any additional or different terms you may have proposed.

Mailing Address: Texas Instruments, Post Office Box 655303, Dallas, Texas 75265
Copyright © 2022, Texas Instruments Incorporated

Looking for pricing, stock, or lifecycle information?

Click below to explore more details on WIN SOURCE:

 [View SN65DP141RLJT on WIN SOURCE](#)

 [Texas Instruments](#) Information

Optimize Your Supply Chain with WIN SOURCE Solutions

-  Global Sourcing Solution
-  Obsolete Management
-  Cost Control Management
-  Shortage Management
-  Alternative Solution
-  Excess Inventory Management