



**THE DATASHEET OF
TS3A4741DGKR**



TS3A474x 0.9-Ω Low-Voltage Single-Supply 2-Channel SPST Analog Switches

1 Features

- Low ON-State Resistance (R_{on})
 - 0.9-Ω Max (3-V Supply)
 - 1.5-Ω Max (1.8-V Supply)
- 0.4-Ω Max R_{on} Flatness (3-V Supply)
- 1.6-V to 3.6-V Single-Supply Operation
- Available in SOT-23 and VSSOP Packages
- High Current-Handling Capacity (100 mA Continuous)
- 1.8-V CMOS Logic Compatible (3-V Supply)
- Fast Switching: $t_{ON} = 14$ ns, $t_{OFF} = 9$ ns

2 Applications

- Power Routing
- Battery-Powered Systems
- Audio and Video Signal Routing
- Low-Voltage Data-Acquisition Systems
- Communications Circuits
- PCMCIA Cards
- Cellular Phones
- Modems
- Hard Drives

3 Description

The TS3A4741 and TS3A4742 are bi-directional, 2-channel single-pole/single-throw (SPST) analog switches with low ON-state resistance (R_{on}), low-voltage, that operate from a single 1.6-V to 3.6-V supply. These devices have fast switching speeds, handle rail-to-rail analog signals, and consume very low quiescent power.

The digital logic input is 1.8-V CMOS compatible when using a single 3-V supply.

The TS3A4741 has two normally open (NO) switches, and the TS3A4742 has two normally closed (NC) switches.

Device Information⁽¹⁾

PART NUMBER	PACKAGE	BODY SIZE (NOM)
TS3A4741	SOT (8)	2.90 mm × 1.63 mm
	VSSOP (8)	3.00 mm × 3.00 mm
TS3A4742	SOT (8)	2.90 mm × 1.63 mm
	VSSOP (8)	3.00 mm × 3.00 mm

(1) For all available packages, see the orderable addendum at the end of the datasheet.

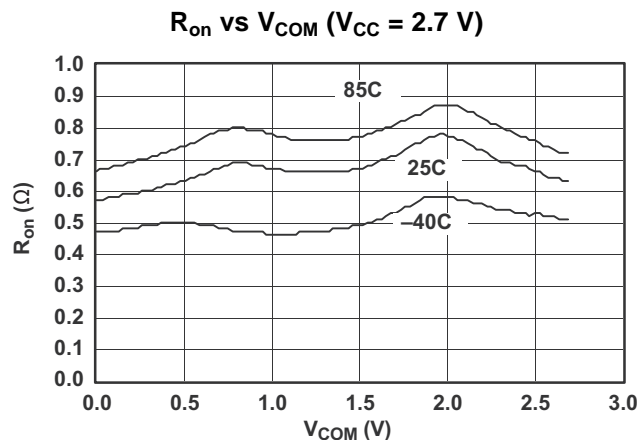

Table of Contents

1 Features	1	8.2 Functional Block Diagram	14
2 Applications	1	8.3 Feature Description	14
3 Description	1	8.4 Device Functional Modes	14
4 Revision History	2	9 Application and Implementation	15
5 Pin Configuration and Functions	3	9.1 Application Information	15
6 Specifications	4	9.2 Typical Application	15
6.1 Absolute Maximum Ratings	4	10 Power Supply Recommendations	17
6.2 ESD Ratings	4	11 Layout	17
6.3 Recommended Operating Conditions	4	11.1 Layout Guidelines	17
6.4 Thermal Information	4	11.2 Layout Example	17
6.5 Electrical Characteristics (3-V Supply)	5	12 Device and Documentation Support	18
6.6 Electrical Characteristics (1.8-V Supply)	7	12.1 Related Links	18
6.7 Typical Characteristics	8	12.2 Trademarks	18
7 Parameter Measurement Information	11	12.3 Electrostatic Discharge Caution	18
8 Detailed Description	14	12.4 Glossary	18
8.1 Overview	14	13 Mechanical, Packaging, and Orderable Information	18

4 Revision History

Changes from Revision E (December 2014) to Revision F Page

- Changed DCN package to clarify switch configuration. **3**
- Changed the V_{IN} MAX value in the *Recommended Operating Conditions* table from: 1.8 V to: V_{CC} **4**

Changes from Revision D (June 2014) to Revision E Page

- Added *Pin Configuration and Functions* section, *ESD Ratings* table, *Feature Description* section, *Device Functional Modes*, *Application and Implementation* section, *Power Supply Recommendations* section, *Layout* section, *Device and Documentation Support* section, and *Mechanical, Packaging, and Orderable Information* section **1**

5 Pin Configuration and Functions

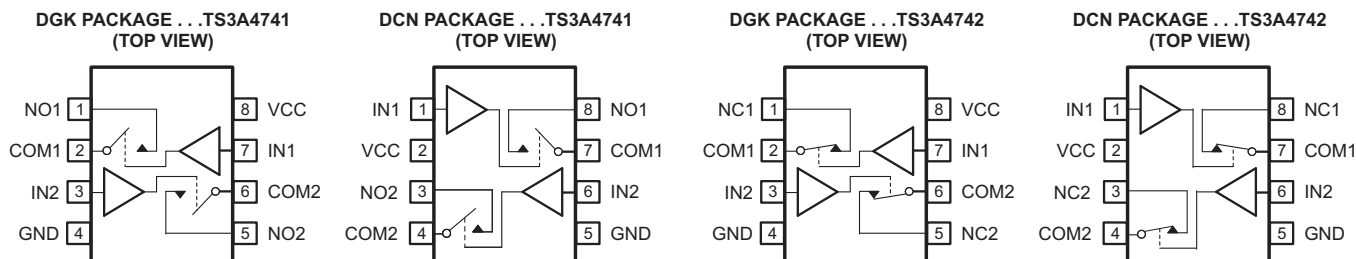

Pin Functions

NAME	PIN				I/O	DESCRIPTION
	TS3A4741		TS3A4742			
	MSOP	SOT	MSOP	SOT		
COM1	2	7	2	7	I/O	Common
COM2	6	4	6	4	I/O	Common
GND	4	5	4	5	—	Ground
IN1	7	1	7	1	I	Digital control to connect COM to NO or NC
IN2	3	6	3	6	I	Digital control to connect COM to NO or NC
NC1	—	—	1	8	I/O	Normally closed
NC2	—	—	5	3	I/O	Normally closed
NO1	1	8	—	—	I/O	Normally open
NO2	5	3	—	—	I/O	Normally open
VCC	8	2	8	2	I	Power supply

6 Specifications

6.1 Absolute Maximum Ratings⁽¹⁾

over operating free-air temperature range (unless otherwise noted)

		MIN	MAX	UNIT
V_{CC}	Supply voltage reference to GND ⁽²⁾	-0.3	4	V
V_{NO} V_{COM} V_{IN}	Analog and digital voltage	-0.3	$V_{CC} + 0.3$	
I_{NO} I_{COM}	On-state switch current $V_{NO}, V_{COM} = 0$ to V_{CC}	-100	100	
I_{CC} I_{GND}	Continuous current through V_{CC} or GND		±100	mA
	Peak current pulsed at 1 ms, 10% duty cycle COM, V_{NO}, V_{COM}		±200	
T_A	Operating temperature	-40	85	°C
T_J	Junction temperature		150	
T_{stg}	Storage temperature	-65	150	

- (1) Stresses beyond those listed under Absolute Maximum Ratings may cause permanent damage to the device. These are stress ratings only, and functional operation of the device at these or any other conditions beyond those indicated under *Recommended Operating Conditions* is not implied. Exposure to absolute-maximum-rated conditions for extended periods may affect device reliability.
- (2) Signals on COM or NO exceeding V_{CC} or GND are clamped by internal diodes. Limit forward diode current to maximum current rating.

6.2 ESD Ratings

		VALUE	UNIT
$V_{(ESD)}$	Electrostatic discharge	Human-body model (HBM), per ANSI/ESDA/JEDEC JS-001 ⁽¹⁾	±4000
		Charged-device model (CDM), per JEDEC specification JESD22-C101 ⁽²⁾	±1000

- (1) JEDEC document JEP155 states that 500-V HBM allows safe manufacturing with a standard ESD control process.
- (2) JEDEC document JEP157 states that 250-V CDM allows safe manufacturing with a standard ESD control process.

6.3 Recommended Operating Conditions

over operating free-air temperature range (unless otherwise noted)

		MIN	MAX	UNIT
V_{CC}	Supply voltage reference to ground	1.6	3.6	V
V_{NO} V_{COM}	Analog voltage	0	3.6	
V_{IN}	Digital Voltage	0	V_{CC}	

6.4 Thermal Information

THERMAL METRIC ⁽¹⁾		TS3A474x	UNIT
		DCN/DGK	
		8 PINS	
$R_{\theta JA}$	Junction-to-ambient thermal resistance	214.8	°C/W
$R_{\theta JC(top)}$	Junction-to-case (top) thermal resistance	191.0	
$R_{\theta JB}$	Junction-to-board thermal resistance	113.1	
Ψ_{JT}	Junction-to-top characterization parameter	52.4	
Ψ_{JB}	Junction-to-board characterization parameter	110.2	

- (1) For more information about traditional and new thermal metrics, see the *IC Package Thermal Metrics* application report, SPRA953.

6.5 Electrical Characteristics (3-V Supply)⁽¹⁾⁽²⁾

 $V_{CC} = 2.7\text{ V to }3.6\text{ V}$, $T_A = -40\text{ to }85^\circ\text{C}$, $V_{IH} = 1.4\text{ V}$, $V_{IL} = 0.5\text{ V}$ (unless otherwise noted)

PARAMETER		TEST CONDITIONS	T_A	MIN	TYP ⁽³⁾	MAX	UNIT
ANALOG SWITCH							
V_{COM}, V_{NO}, V_{NC}	Analog signal range			0		V_+	V
R_{on}	ON-state resistance	$V_{CC} = 2.7\text{ V}, I_{COM} = -100\text{ mA}, V_{NO}, V_{NC} = 1.5\text{ V}$	25°C		0.7	0.9	Ω
			Full			1.1	
ΔR_{on}	ON-state resistance match between channels ⁽⁴⁾	$V_{CC} = 2.7\text{ V}, I_{COM} = -100\text{ mA}, V_{NO}, V_{NC} = 1.5\text{ V}$	25°C		0.03	0.05	Ω
			Full			0.15	
$R_{on(Flat)}$	ON-state resistance flatness ⁽⁵⁾	$V_{CC} = 2.7\text{ V}, I_{COM} = -100\text{ mA}, V_{NO}, V_{NC} = 1\text{ V}, 1.5\text{ V}, 2\text{ V}$	25°C		0.23	0.4	Ω
			Full			0.5	
$I_{NO(OFF)}$	NO OFF leakage current ⁽⁶⁾	$V_{CC} = 3.6\text{ V}, V_{COM} = 0.3\text{ V}, 3\text{ V}, V_{NO} = 3\text{ V}, 0.3\text{ V}$	25°C	-2	1	2	nA
			Full	-18		18	
$I_{COM(OFF)}$	COM OFF leakage current ⁽⁶⁾	$V_{CC} = 3.6\text{ V}, V_{COM} = 0.3\text{ V}, 3\text{ V}, V_{NO} = 3\text{ V}, 0.3\text{ V}$	25°C	-2	1	2	nA
			Full	-18		18	
$I_{COM(ON)}$	COM ON leakage current ⁽⁶⁾	$V_{CC} = 3.6\text{ V}, V_{COM} = 0.3\text{ V}, 3\text{ V}, V_{NO} = 0.3\text{ V}, 3\text{ V}, \text{ or floating}$	25°C	-2.5	0.01	2.5	nA
			Full	-5		5	
DYNAMIC							
t_{ON}	Turn-on time	$V_{NO}, V_{NC} = 1.5\text{ V}, R_L = 50\ \Omega, C_L = 35\text{ pF}$, See Figure 14	25°C		5	14	ns
			Full			15	
t_{OFF}	Turn-off time	$V_{NO}, V_{NC} = 1.5\text{ V}, R_L = 50\ \Omega, C_L = 35\text{ pF}$, See Figure 14	25°C		4	9	ns
			Full			10	
Q_C	Charge injection	$V_{GEN} = 0, R_{GEN} = 0, C_L = 1\text{ nF}$, See Figure 15	25°C		3		pC
$C_{NO(OFF)}$	NO OFF capacitance	$f = 1\text{ MHz}$, See Figure 16	25°C		23		pF
$C_{COM(OFF)}$	COM OFF capacitance	$f = 1\text{ MHz}$, See Figure 16	25°C		20		
$C_{COM(ON)}$	COM ON capacitance	$f = 1\text{ MHz}$, See Figure 16	25°C		43		
BW	Bandwidth	$R_L = 50\ \Omega$, Switch ON	25°C		125		MHz
O_{ISO}	OFF isolation ⁽⁷⁾	$R_L = 50\ \Omega, C_L = 5\text{ pF}$, See Figure 17	25°C	$f = 10\text{ MHz}$	-40		dB
				$f = 1\text{ MHz}$	-62		
X_{TALK}	Crosstalk	$R_L = 50\ \Omega, C_L = 5\text{ pF}$, See Figure 17	25°C	$f = 10\text{ MHz}$	-73		dB
				$f = 1\text{ MHz}$	-95		
THD	Total harmonic distortion	$f = 20\text{ Hz to }20\text{ kHz}, V_{COM} = 2\text{ V}_{P-P}$	25°C	$R_L = 32\ \Omega$	0.04%		
				$R_L = 600\ \Omega$	0.003%		
DIGITAL CONTROL INPUTS (IN1, IN2)							
V_{IH}	Input logic high		Full	1.4			V
V_{IL}	Input logic low		Full			0.5	
I_{IN}	Input leakage current	$V_I = 0\text{ or }V_{CC}$	25°C		0.5	1	nA
			Full	-20		20	
SUPPLY							

(1) The algebraic convention, whereby the most negative value is a minimum and the most positive value is a maximum.

(2) Parts are tested at 85°C and specified by design and correlation over the full temperature range.

(3) Typical values are at $V_{CC} = 3\text{ V}$, $T_A = 25^\circ\text{C}$.

(4) $\Delta R_{on} = R_{on(max)} - R_{on(min)}$

(5) Flatness is defined as the difference between the maximum and minimum value of r_{on} as measured over the specified analog signal ranges.

(6) Leakage parameters are 100% tested at the maximum-rated hot operating temperature and specified by correlation at $T_A = 25^\circ\text{C}$.

(7) OFF isolation = $20_{\log}10 (V_{COM}/V_{NO})$, V_{COM} = output, V_{NO} = input to OFF switch

Electrical Characteristics (3-V Supply)⁽¹⁾⁽²⁾ (continued)
 $V_{CC} = 2.7\text{ V to }3.6\text{ V}$, $T_A = -40\text{ to }85^\circ\text{C}$, $V_{IH} = 1.4\text{ V}$, $V_{IL} = 0.5\text{ V}$ (unless otherwise noted)

PARAMETER		TEST CONDITIONS	T_A	MIN	TYP ⁽³⁾	MAX	UNIT
V_{CC}	Power-supply range			2.7		3.6	V
I_{CC}	Positive-supply current	$V_{CC} = 3.6\text{ V}$, $V_{IN} = 0\text{ or }V_{CC}$	25°C			0.075	μA
			Full			0.75	

6.6 Electrical Characteristics (1.8-V Supply)^{(1) (2)}

 $V_{CC} = 1.65\text{ V to }1.95\text{ V}$, $T_A = -40\text{ to }85^\circ\text{C}$, $V_{IH} = 1\text{ V}$, $V_{IL} = 0.4\text{ V}$ (unless otherwise noted)

PARAMETER		TEST CONDITIONS	T_A	MIN	TYP ⁽²⁾	MAX	UNIT
ANALOG SWITCH							
V_{COM}, V_{NO}, V_{NC}	Analog signal range			0		V_+	V
R_{on}	ON-state resistance	$V_{CC} = 1.8\text{ V}$, $I_{COM} = -10\text{ mA}$, $V_{NO}, V_{NC} = 0.9\text{ V}$	25 °C		1	1.5	Ω
			Full			2	
ΔR_{on}	ON-state resistance match between channels ⁽¹⁾	$V_{CC} = 1.8\text{ V}$, $I_{COM} = -10\text{ mA}$, $V_{NO}, V_{NC} = 0.9\text{ V}$	25 °C		0.09	0.15	Ω
			Full			0.25	
$R_{on(Flat)}$	ON-state resistance flatness ⁽³⁾	$V_{CC} = 1.8\text{ V}$, $I_{COM} = -10\text{ mA}$, $0 \leq V_{NO}, V_{NC} \leq V_{CC}$	25 °C		0.7	0.9	Ω
			Full			1.5	
$I_{NO(OFF)}$	NO OFF leakage current ⁽⁴⁾	$V_{CC} = 1.95\text{ V}$, $V_{COM} = 0.15\text{ V}$, 1.65 V , $V_{NO} = 1.8\text{ V}$, 0.15 V	25 °C	-1	0.5	1	nA
			Full	-10		10	
$I_{COM(OFF)}$	COM OFF leakage current ⁽⁴⁾	$V_{CC} = 1.95\text{ V}$, $V_{COM} = 0.15\text{ V}$, 1.65 V , $V_{NO} = 1.8\text{ V}$, 0.15 V	25 °C	-1	0.5	1	nA
			Full	-10		10	
$I_{COM(ON)}$	COM ON leakage current ⁽⁴⁾	$V_{CC} = 1.95\text{ V}$, $V_{COM} = 0.15\text{ V}$, 1.65 V , $V_{NO} = 0.15\text{ V}$, 1.65 V , or floating	25 °C	-1	0.01	1	nA
			Full	-3		3	
DYNAMIC							
t_{ON}	Turn-on time	$V_{NO}, V_{NC} = 1.5\text{ V}$, $R_L = 50\ \Omega$, $C_L = 35\text{ pF}$, See Figure 14	25 °C		6	18	ns
			Full			20	
t_{OFF}	Turn-off time	$V_{NO}, V_{NC} = 1.5\text{ V}$, $R_L = 50\ \Omega$, $C_L = 35\text{ pF}$, See Figure 14	25 °C		5	10	ns
			Full			12	
Q_C	Charge injection	$V_{GEN} = 0$, $R_{GEN} = 0$, $C_L = 1\text{ nF}$, See Figure 15	25 °C		3.2		pC
$C_{NO(OFF)}$	NO OFF capacitance	$f = 1\text{ MHz}$, See Figure 16	25 °C		23		pF
$C_{COM(OFF)}$	COM OFF capacitance	$f = 1\text{ MHz}$, See Figure 16	25 °C		20		
$C_{COM(ON)}$	COM ON capacitance	$f = 1\text{ MHz}$, See Figure 16	25 °C		43		
BW	Bandwidth	$R_L = 50\ \Omega$, Switch ON	25 °C		123		MHz
O_{ISO}	OFF isolation ⁽⁵⁾	$R_L = 50\ \Omega$, $C_L = 5\text{ pF}$, See Figure 17	f = 10 MHz	25 °C		-61	dB
			f = 100 MHz			-36	
X_{TALK}	Crosstalk	$R_L = 50\ \Omega$, $C_L = 5\text{ pF}$, See Figure 17	f = 10 MHz	25 °C		-95	dB
			f = 100 MHz			-73	
THD	Total harmonic distortion	f = 20 Hz to 20 kHz, $V_{COM} = 2\text{ V}_{P-P}$	$R_L = 32\ \Omega$	25 °C		0.14%	
			$R_L = 600\ \Omega$			0.013%	
DIGITAL CONTROL INPUTS (IN1, IN2)							
V_{IH}	Input logic high		Full	1			V
V_{IL}	Input logic low		Full			0.4	
I_{IN}	Input leakage current	$V_I = 0\text{ or }V_{CC}$	25 °C		0.1	5	nA
			Full		-10	10	
SUPPLY							
V_{CC}	Power-supply range			1.65		1.95	V
I_{CC}	Positive-supply current	$V_I = 0\text{ or }V_{CC}$	25 °C			0.05	μA
			Full			0.5	

(1) $\Delta R_{on} = R_{on(max)} - R_{on(min)}$

(2) Typical values are at $T_A = 25^\circ\text{C}$.

(3) Flatness is defined as the difference between the maximum and minimum value of r_{on} as measured over the specified analog signal ranges.

(4) Leakage parameters are 100% tested at the maximum-rated hot operating temperature and specified by correlation at $T_A = 25^\circ\text{C}$.

(5) OFF isolation = $20 \log_{10} (V_{COM}/V_{NO})$, V_{COM} = output, V_{NO} = input to OFF switch

6.7 Typical Characteristics

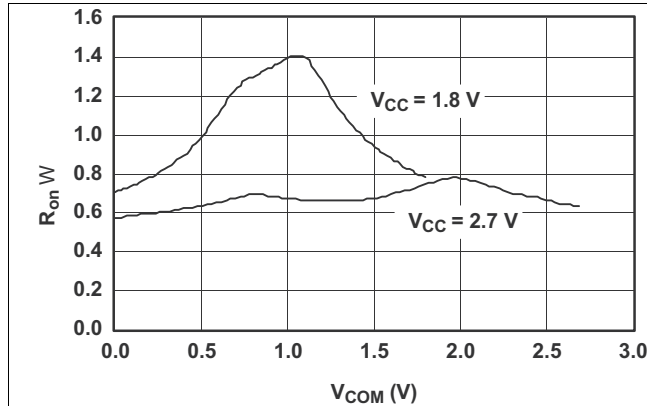
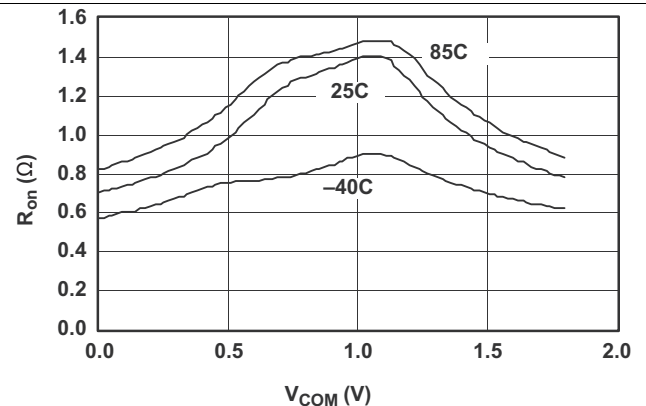
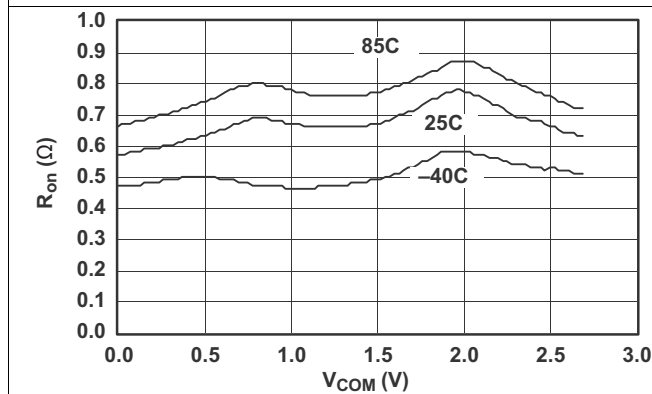
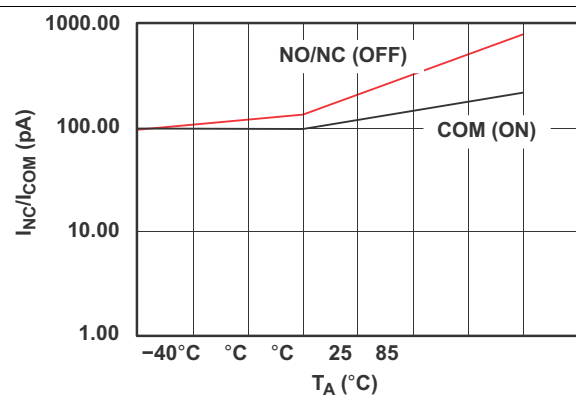
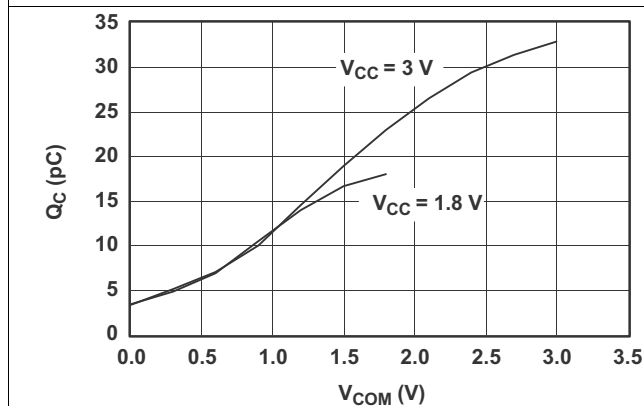
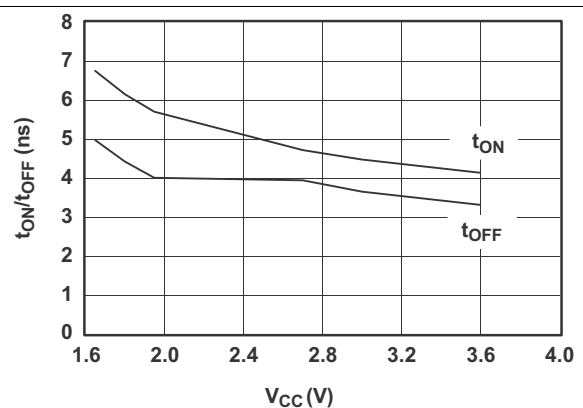
Figure 1. R_{on} vs V_{COM}

Figure 2. R_{on} vs V_{COM} ($V_{CC} = 1.8$ V)

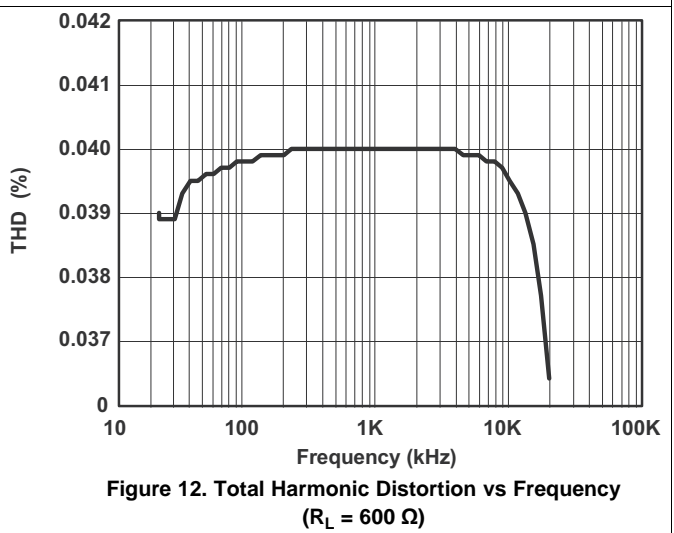
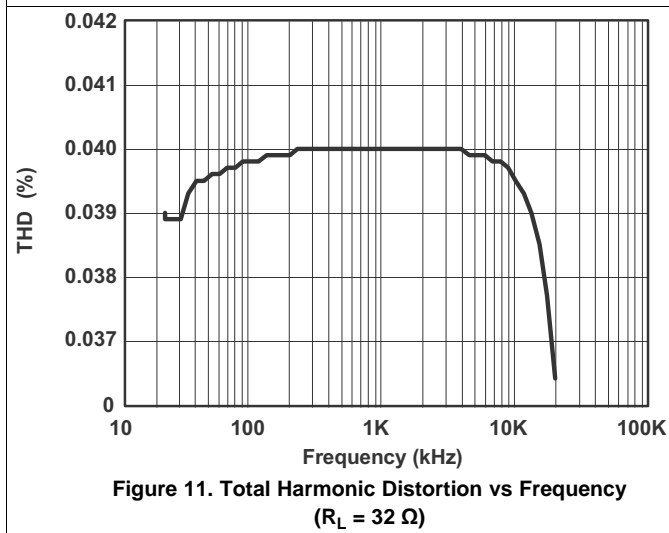
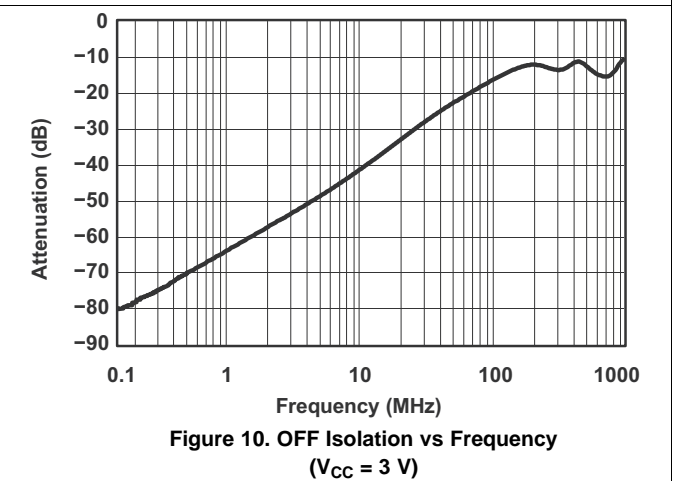
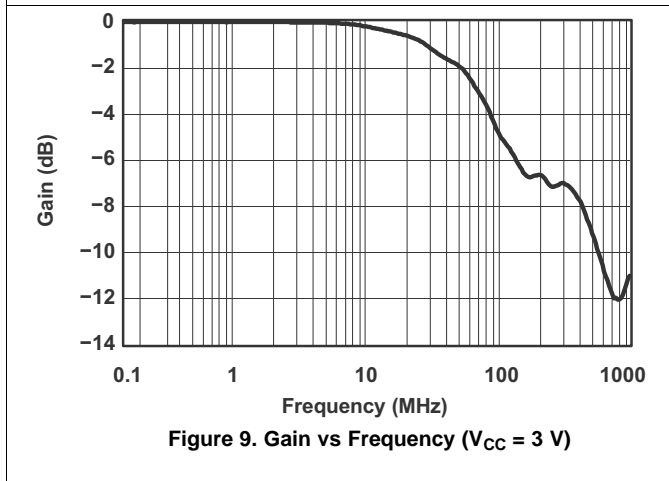
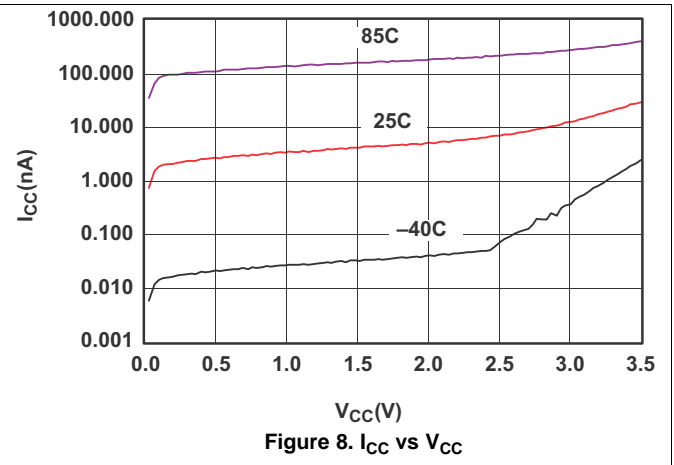
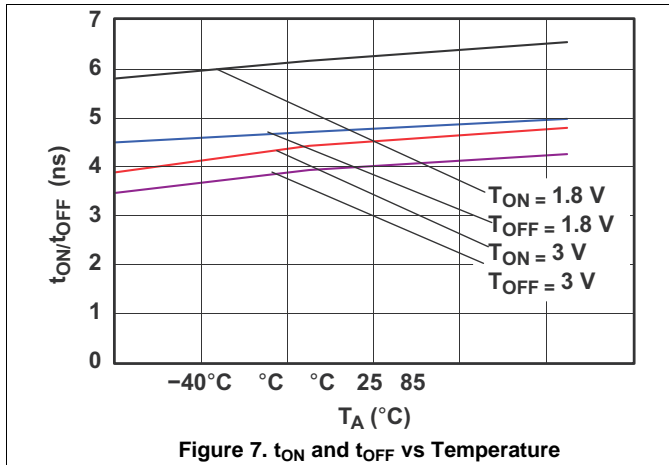
Figure 3. R_{on} vs V_{COM} ($V_{CC} = 2.7$ V)

Figure 4. I_{ON} and I_{OFF} vs Temperature ($V_{CC} = 3.6$ V)

Figure 5. Q_C vs V_{COM}

Figure 6. t_{ON} and t_{OFF} vs Supply Voltage

Typical Characteristics (continued)



Typical Characteristics (continued)

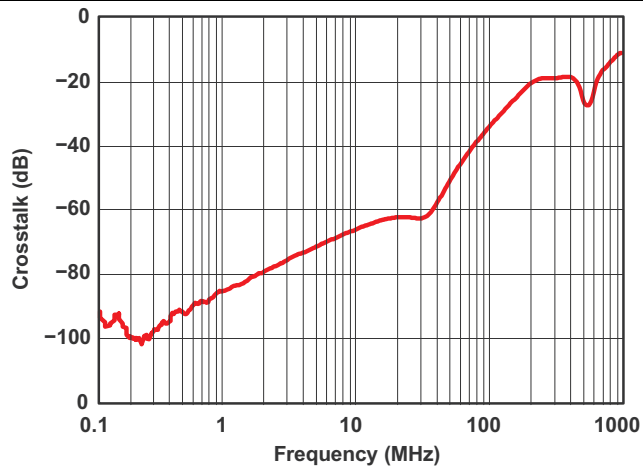

Figure 13. Crosstalk vs Frequency
($V_{CC} = 3\text{ V}$)

7 Parameter Measurement Information

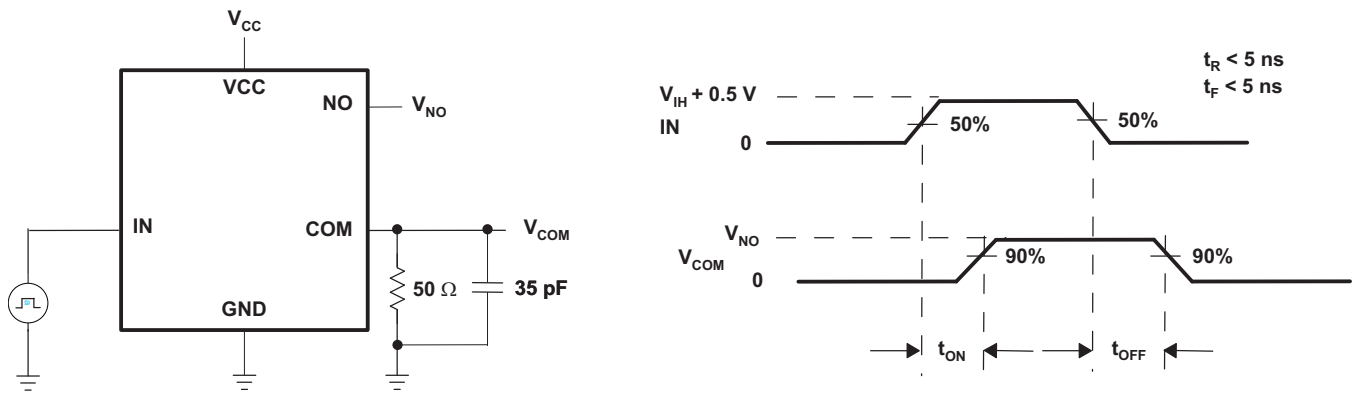

Figure 14. Switching Times

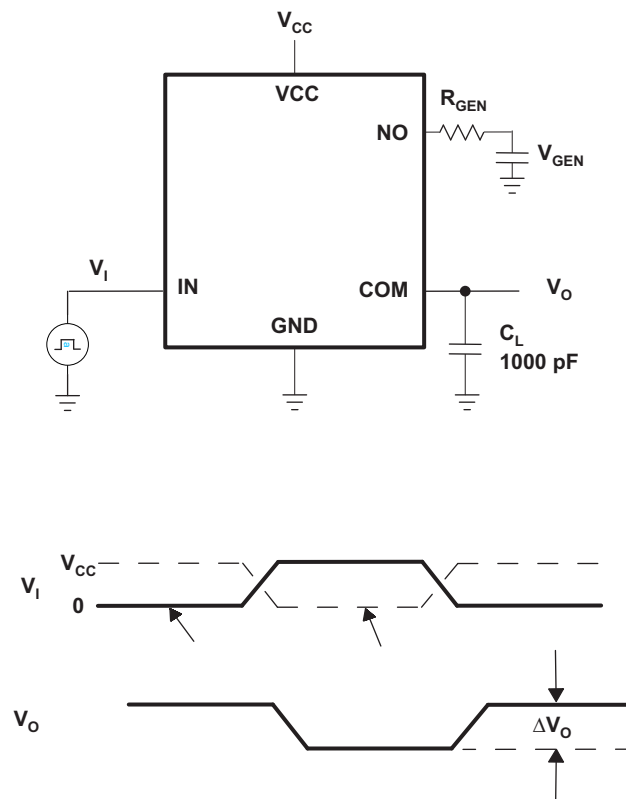

Figure 15. Charge Injection (Q_C)

Parameter Measurement Information (continued)

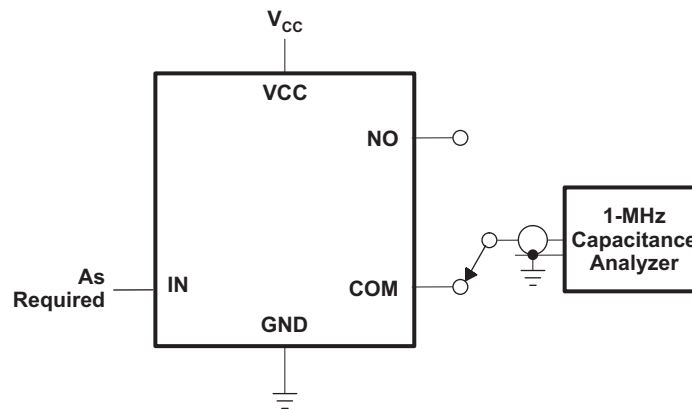
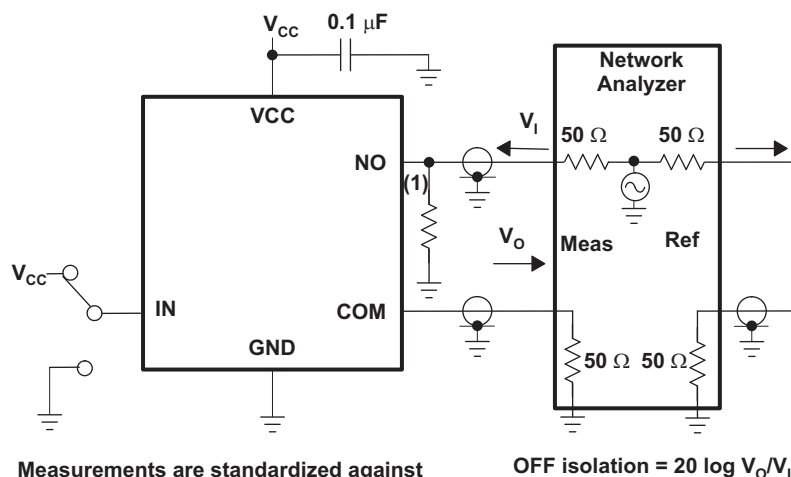

Figure 16. NO and COM Capacitance



Measurements are standardized against short at socket terminals. OFF isolation is measured between COM and OFF terminals on each switch. Bandwidth is measured between COM and ON terminals on each switch. Signal direction through switch is reversed; worst values are recorded.

$$\text{OFF isolation} = 20 \log V_o/V_i$$

⁽¹⁾ Add 50-Ω termination for OFF isolation

Figure 17. OFF Isolation, Bandwidth, and Crosstalk

Parameter Measurement Information (continued)

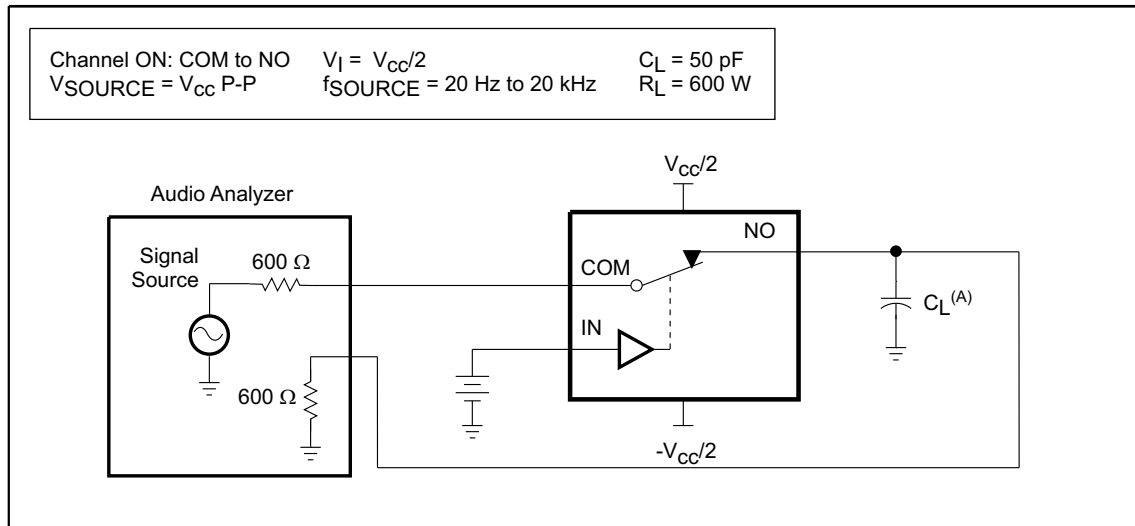

A. C_L includes probe and jig capacitance.

Figure 18. Total Harmonic Distortion (THD)

8 Detailed Description

8.1 Overview

The TS3A4741 and TS3A4742 are bi-directional, 2-channel single-pole/single-throw (SPST) analog switches with low ON-state resistance (R_{on}), low-voltage, that operate from a single 1.6-V to 3.6-V supply. These devices have fast switching speeds, handle rail-to-rail analog signals, and consume very low quiescent power.

The digital logic input is 1.8-V CMOS compatible when using a single 3-V supply.

The TS3A4741 has two normally open (NO) switches, and the TS3A4742 has two normally closed (NC) switches.

8.2 Functional Block Diagram

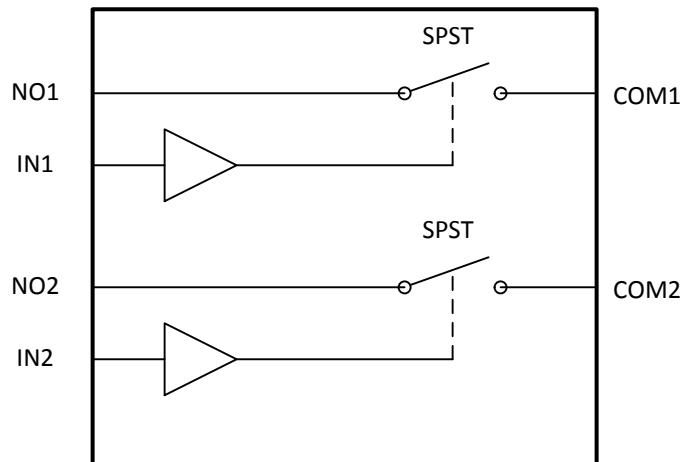

8.3 Feature Description

The TS3A4741 and TS3A4742 has a low on resistance and high current handling capability up to 100 mA continuous current so it can be used for power sequencing and routing with minimal losses. The switch is also bi-directional with fast switching times in the 10 ns range which allows data acquisition and communication between multiple devices.

With a 3-V supply these devices are compatible with standard 1.8-V CMOS logic.

8.4 Device Functional Modes

Table 1. Function Table

IN	NO to COM, COM to NO (TS3A4741)	NC to COM, COM to NC (TS3A4742)
L	OFF	ON
H	ON	OFF

9 Application and Implementation

NOTE

Information in the following applications sections is not part of the TI component specification, and TI does not warrant its accuracy or completeness. TI's customers are responsible for determining suitability of components for their purposes. Customers should validate and test their design implementation to confirm system functionality.

9.1 Application Information

Analog signals that range over the entire supply voltage (V_{CC} to GND) of the TS3A4741 and TS3A4742 can be passed with very little change in R_{on} (see *Typical Characteristics*). The switches are bidirectional, so the NO, NC, and COM pins can be used as either inputs or outputs.

9.2 Typical Application

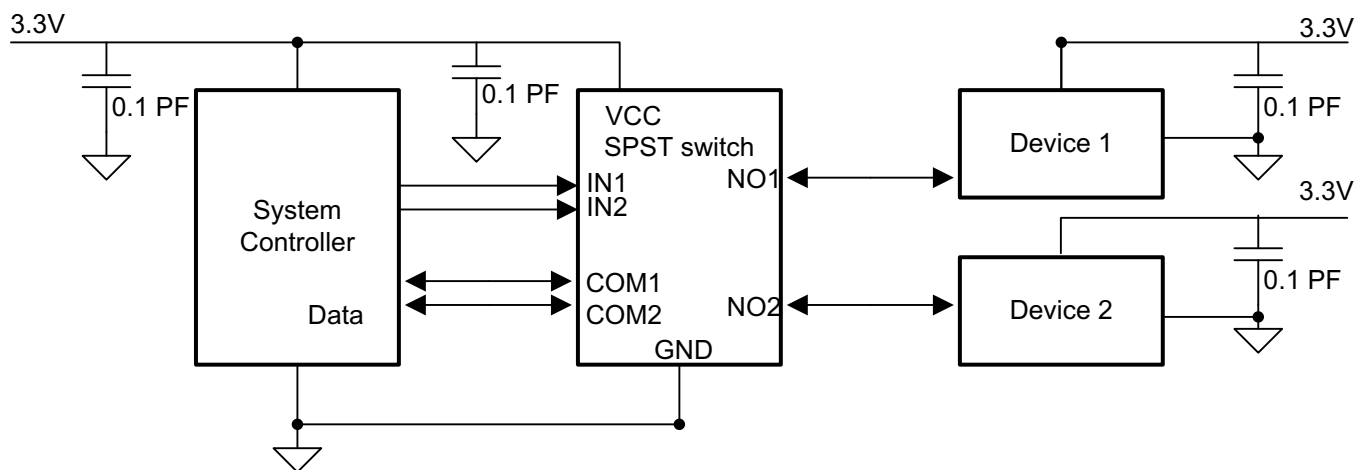

Figure 19. Typical Application Schematic

9.2.1 Design Requirements

Ensure that all of the signals passing through the switch are within the specified ranges to ensure proper performance.

9.2.2 Detailed Design Procedure

The TS3A474x can be properly operated without any external components. However, TI recommends that unused pins should be connected to ground through a 50- Ω resistor to prevent signal reflections back into the device. TI also recommends that the digital control pins (INx) be pulled up to V_{CC} or down to GND to avoid undesired switch positions that could result from the floating pin.

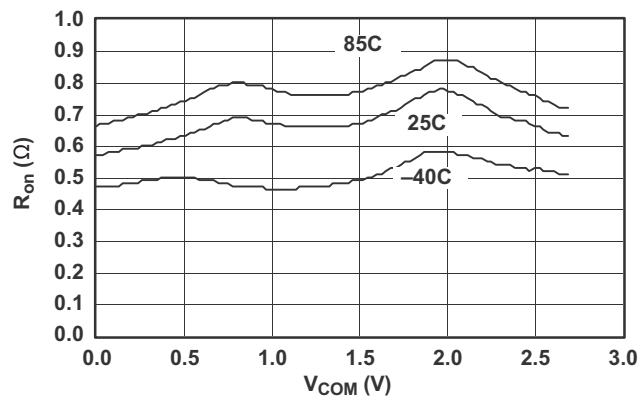
Typical Application (continued)
9.2.3 Application Curve

Figure 20. R_{on} vs V_{COM} ($V_{CC} = 2.7$ V)

10 Power Supply Recommendations

Proper power-supply sequencing is recommended for all CMOS devices. Do not exceed the absolute maximum ratings, because stresses beyond the listed ratings can cause permanent damage to the device. Always sequence VCC on first, followed by NO, NC, or COM.

Although it is not required, power-supply bypassing improves noise margin and prevents switching noise propagation from the VCC supply to other components. A 0.1- μ F capacitor, connected from VCC to GND, is adequate for most applications.

11 Layout

11.1 Layout Guidelines

High-speed switches require proper layout and design procedures for optimum performance. Reduce stray inductance and capacitance by keeping traces short and wide. Ensure that bypass capacitors are as close to the device as possible. Use large ground planes where possible. Use large ground planes where possible.

11.2 Layout Example

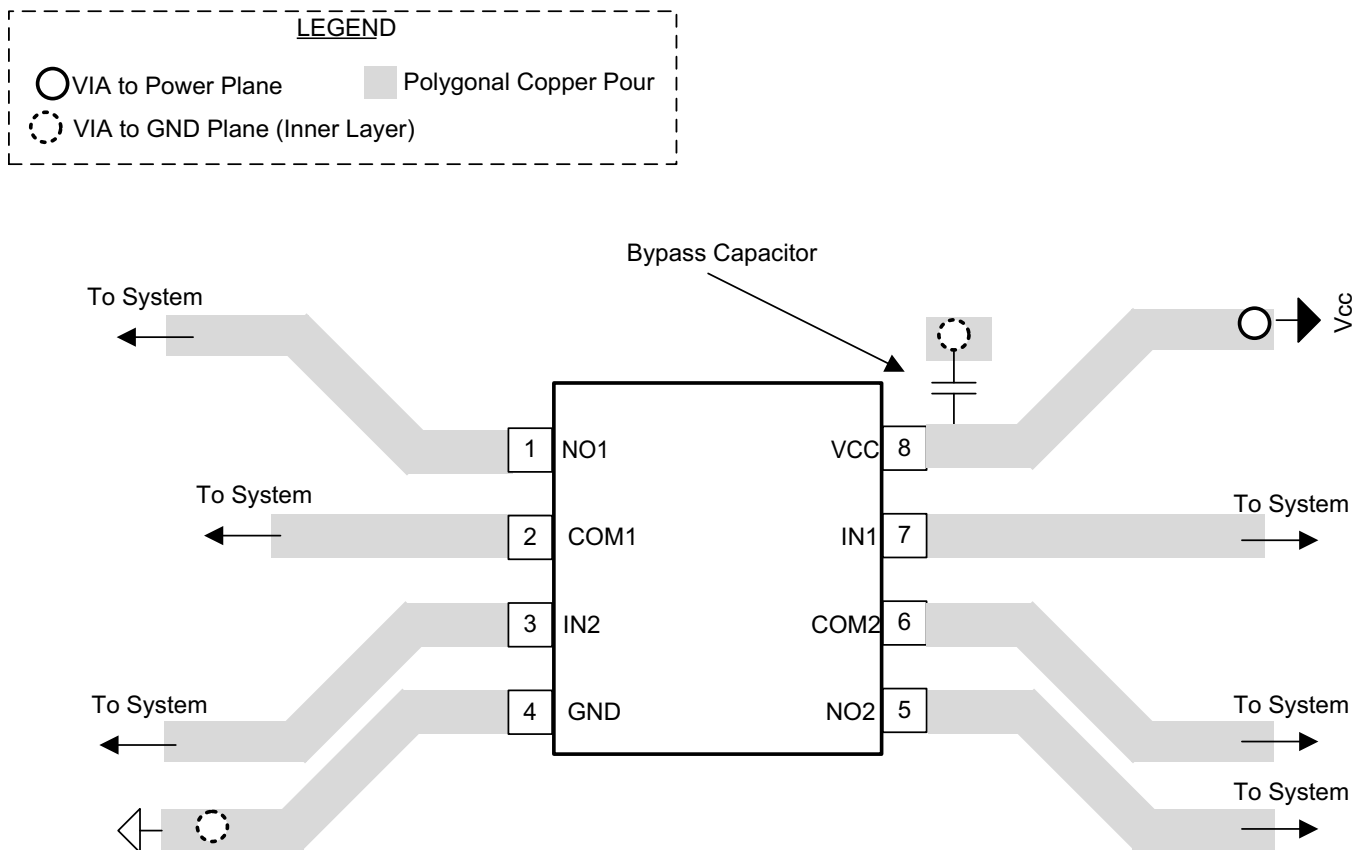

Figure 21. PCB Layout Example

12 Device and Documentation Support

12.1 Related Links

The table below lists quick access links. Categories include technical documents, support and community resources, tools and software, and quick access to sample or buy.

Table 2. Related Links

PARTS	PRODUCT FOLDER	SAMPLE & BUY	TECHNICAL DOCUMENTS	TOOLS & SOFTWARE	SUPPORT & COMMUNITY
TS3A4741	Click here	Click here	Click here	Click here	Click here
TS3A4742	Click here	Click here	Click here	Click here	Click here

12.2 Trademarks

All trademarks are the property of their respective owners.

12.3 Electrostatic Discharge Caution



These devices have limited built-in ESD protection. The leads should be shorted together or the device placed in conductive foam during storage or handling to prevent electrostatic damage to the MOS gates.

12.4 Glossary

[SLYZ022](#) — *TI Glossary*.

This glossary lists and explains terms, acronyms, and definitions.

13 Mechanical, Packaging, and Orderable Information

The following pages include mechanical, packaging, and orderable information. This information is the most current data available for the designated devices. This data is subject to change without notice and revision of this document. For browser-based versions of this data sheet, refer to the left-hand navigation.

PACKAGING INFORMATION

Orderable Device	Status (1)	Package Type	Package Drawing	Pins	Package Qty	Eco Plan (2)	Lead finish/ Ball material (6)	MSL Peak Temp (3)	Op Temp (°C)	Device Marking (4/5)	Samples
TS3A4741DCNR	ACTIVE	SOT-23	DCN	8	3000	RoHS & Green	NIPDAU	Level-1-260C-UNLIM	-40 to 85	(8BLO, 8BLR)	Samples
TS3A4741DGKR	ACTIVE	VSSOP	DGK	8	2500	RoHS & Green	NIPDAU	Level-1-260C-UNLIM	-40 to 85	JYR	Samples
TS3A4742DCNR	ACTIVE	SOT-23	DCN	8	3000	RoHS & Green	NIPDAU	Level-1-260C-UNLIM	-40 to 85	(8BPO, 8BPR)	Samples
TS3A4742DGKR	ACTIVE	VSSOP	DGK	8	2500	RoHS & Green	NIPDAU	Level-1-260C-UNLIM	-40 to 85	L7R	Samples

(1) The marketing status values are defined as follows:

ACTIVE: Product device recommended for new designs.

LIFEBUY: TI has announced that the device will be discontinued, and a lifetime-buy period is in effect.

NRND: Not recommended for new designs. Device is in production to support existing customers, but TI does not recommend using this part in a new design.

PREVIEW: Device has been announced but is not in production. Samples may or may not be available.

OBSOLETE: TI has discontinued the production of the device.

(2) **RoHS:** TI defines "RoHS" to mean semiconductor products that are compliant with the current EU RoHS requirements for all 10 RoHS substances, including the requirement that RoHS substance do not exceed 0.1% by weight in homogeneous materials. Where designed to be soldered at high temperatures, "RoHS" products are suitable for use in specified lead-free processes. TI may reference these types of products as "Pb-Free".

RoHS Exempt: TI defines "RoHS Exempt" to mean products that contain lead but are compliant with EU RoHS pursuant to a specific EU RoHS exemption.

Green: TI defines "Green" to mean the content of Chlorine (Cl) and Bromine (Br) based flame retardants meet JS709B low halogen requirements of <=1000ppm threshold. Antimony trioxide based flame retardants must also meet the <=1000ppm threshold requirement.

(3) MSL, Peak Temp. - The Moisture Sensitivity Level rating according to the JEDEC industry standard classifications, and peak solder temperature.

(4) There may be additional marking, which relates to the logo, the lot trace code information, or the environmental category on the device.

(5) Multiple Device Markings will be inside parentheses. Only one Device Marking contained in parentheses and separated by a "-" will appear on a device. If a line is indented then it is a continuation of the previous line and the two combined represent the entire Device Marking for that device.

(6) Lead finish/Ball material - Orderable Devices may have multiple material finish options. Finish options are separated by a vertical ruled line. Lead finish/Ball material values may wrap to two lines if the finish value exceeds the maximum column width.

Important Information and Disclaimer:The information provided on this page represents TI's knowledge and belief as of the date that it is provided. TI bases its knowledge and belief on information provided by third parties, and makes no representation or warranty as to the accuracy of such information. Efforts are underway to better integrate information from third parties. TI has taken and

continues to take reasonable steps to provide representative and accurate information but may not have conducted destructive testing or chemical analysis on incoming materials and chemicals. TI and TI suppliers consider certain information to be proprietary, and thus CAS numbers and other limited information may not be available for release.

In no event shall TI's liability arising out of such information exceed the total purchase price of the TI part(s) at issue in this document sold by TI to Customer on an annual basis.

TAPE AND REEL INFORMATION

QUADRANT ASSIGNMENTS FOR PIN 1 ORIENTATION IN TAPE

*All dimensions are nominal

Device	Package Type	Package Drawing	Pins	SPQ	Reel Diameter (mm)	Reel Width W1 (mm)	A0 (mm)	B0 (mm)	K0 (mm)	P1 (mm)	W (mm)	Pin1 Quadrant
TS3A4741DCNR	SOT-23	DCN	8	3000	180.0	8.4	3.23	3.17	1.37	4.0	8.0	Q3
TS3A4741DGKR	VSSOP	DGK	8	2500	330.0	12.4	5.3	3.4	1.4	8.0	12.0	Q1
TS3A4742DCNR	SOT-23	DCN	8	3000	180.0	8.4	3.23	3.17	1.37	4.0	8.0	Q3
TS3A4742DGKR	VSSOP	DGK	8	2500	330.0	12.4	5.3	3.4	1.4	8.0	12.0	Q1

TAPE AND REEL BOX DIMENSIONS

*All dimensions are nominal

Device	Package Type	Package Drawing	Pins	SPQ	Length (mm)	Width (mm)	Height (mm)
TS3A4741DCNR	SOT-23	DCN	8	3000	202.0	201.0	28.0
TS3A4741DGKR	VSSOP	DGK	8	2500	358.0	335.0	35.0
TS3A4742DCNR	SOT-23	DCN	8	3000	202.0	201.0	28.0
TS3A4742DGKR	VSSOP	DGK	8	2500	358.0	335.0	35.0

DGK0008A



PACKAGE OUTLINE

VSSOP - 1.1 mm max height

SMALL OUTLINE PACKAGE

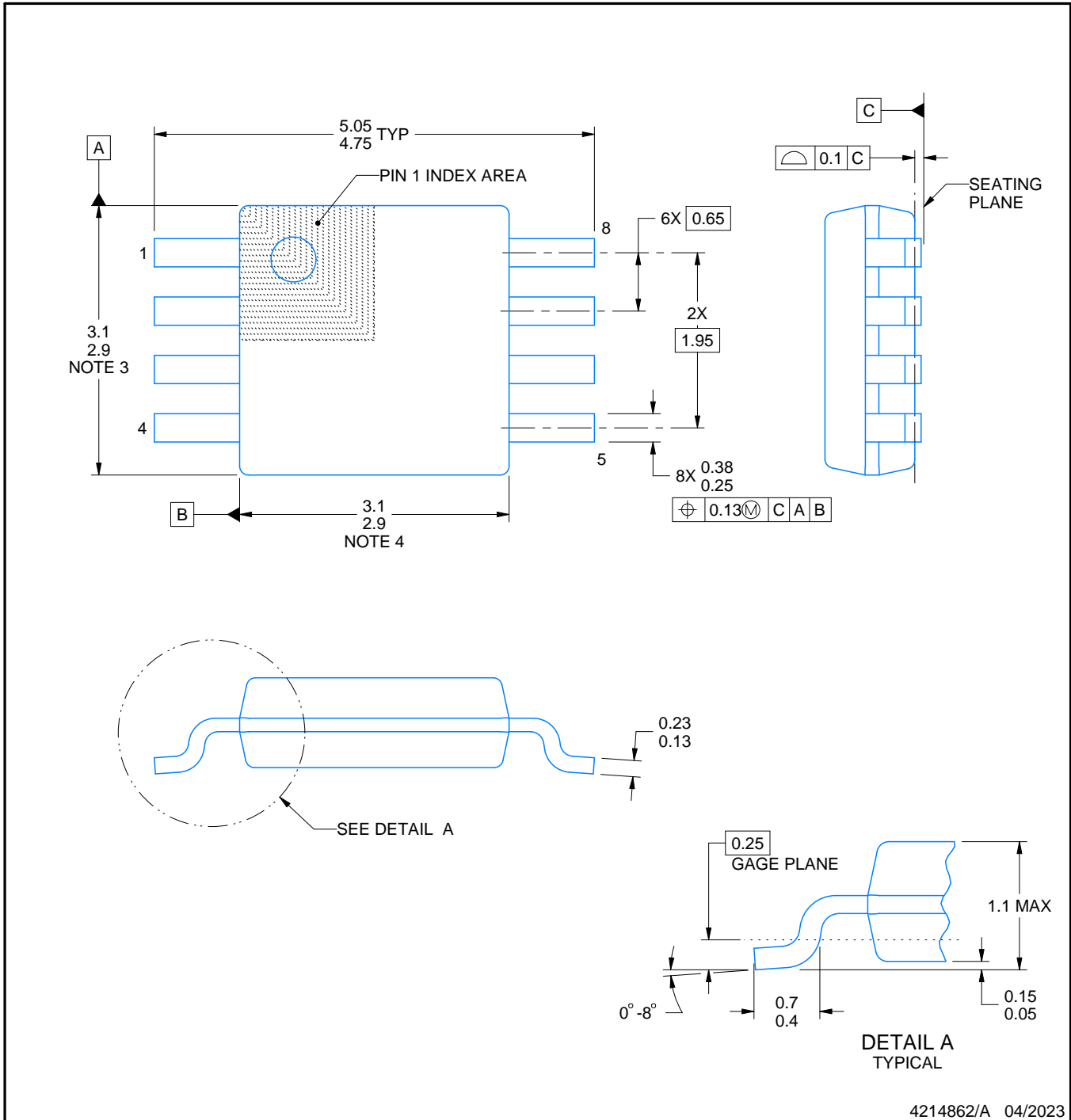

NOTES:

PowerPAD is a trademark of Texas Instruments.

1. All linear dimensions are in millimeters. Any dimensions in parenthesis are for reference only. Dimensioning and tolerancing per ASME Y14.5M.
2. This drawing is subject to change without notice.
3. This dimension does not include mold flash, protrusions, or gate burrs. Mold flash, protrusions, or gate burrs shall not exceed 0.15 mm per side.
4. This dimension does not include interlead flash. Interlead flash shall not exceed 0.25 mm per side.
5. Reference JEDEC registration MO-187.

EXAMPLE BOARD LAYOUT

DGK0008A

™ VSSOP - 1.1 mm max height

SMALL OUTLINE PACKAGE



LAND PATTERN EXAMPLE
EXPOSED METAL SHOWN
SCALE: 15X



SOLDER MASK DETAILS

4214862/A 04/2023

NOTES: (continued)

6. Publication IPC-7351 may have alternate designs.
7. Solder mask tolerances between and around signal pads can vary based on board fabrication site.
8. Vias are optional depending on application, refer to device data sheet. If any vias are implemented, refer to their locations shown on this view. It is recommended that vias under paste be filled, plugged or tented.
9. Size of metal pad may vary due to creepage requirement.

EXAMPLE STENCIL DESIGN

DGK0008A

TM VSSOP - 1.1 mm max height

SMALL OUTLINE PACKAGE



SOLDER PASTE EXAMPLE
SCALE: 15X

4214862/A 04/2023

NOTES: (continued)

11. Laser cutting apertures with trapezoidal walls and rounded corners may offer better paste release. IPC-7525 may have alternate design recommendations.
12. Board assembly site may have different recommendations for stencil design.

DCN (R-PDSO-G8)

PLASTIC SMALL-OUTLINE PACKAGE (DIE DOWN)

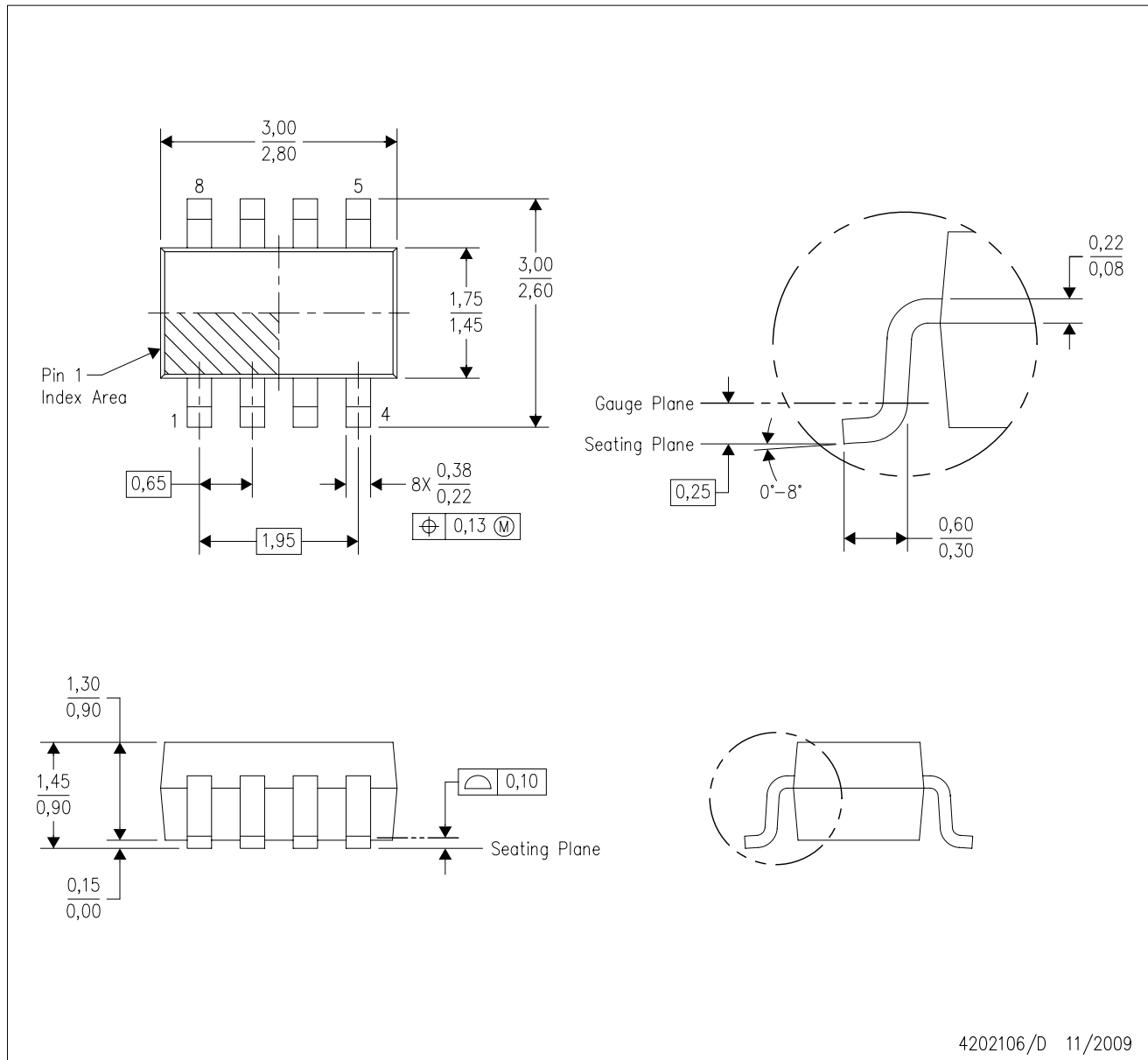

- NOTES:
- A. All linear dimensions are in millimeters.
 - B. This drawing is subject to change without notice.
 - C. Package outline exclusive of metal burr & dambar protrusion/intrusion.
 - D. Package outline inclusive of solder plating.
 - E. A visual index feature must be located within the Pin 1 index area.
 - F. Falls within JEDEC MO-178 Variation BA.
 - G. Body dimensions do not include flash or protrusion. Mold flash and protrusion shall not exceed 0.25 per side.

DCN (R-PDSO-G8)

PLASTIC SMALL-OUTLINE PACKAGE (DIE DOWN)

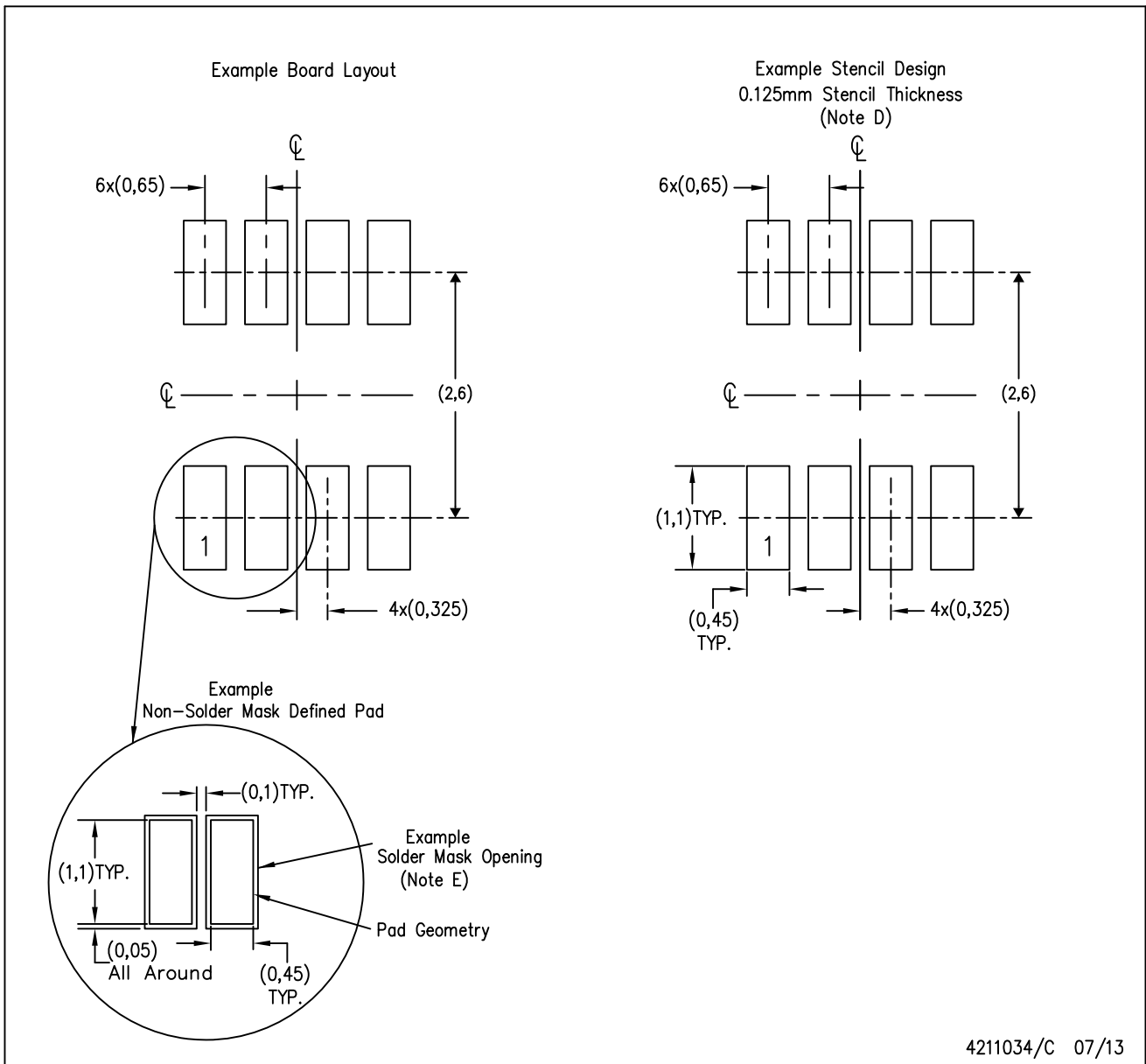

- NOTES:
- A. All linear dimensions are in millimeters.
 - B. This drawing is subject to change without notice.
 - C. Publication IPC-7351 is recommended for alternate designs.
 - D. Laser cutting apertures with trapezoidal walls and also rounding corners will offer better paste release. Customers should contact their board assembly site for stencil design recommendations. Refer to IPC-7525.
 - E. Customers should contact their board fabrication site for solder mask tolerances between and around signal pads.

IMPORTANT NOTICE AND DISCLAIMER

TI PROVIDES TECHNICAL AND RELIABILITY DATA (INCLUDING DATA SHEETS), DESIGN RESOURCES (INCLUDING REFERENCE DESIGNS), APPLICATION OR OTHER DESIGN ADVICE, WEB TOOLS, SAFETY INFORMATION, AND OTHER RESOURCES "AS IS" AND WITH ALL FAULTS, AND DISCLAIMS ALL WARRANTIES, EXPRESS AND IMPLIED, INCLUDING WITHOUT LIMITATION ANY IMPLIED WARRANTIES OF MERCHANTABILITY, FITNESS FOR A PARTICULAR PURPOSE OR NON-INFRINGEMENT OF THIRD PARTY INTELLECTUAL PROPERTY RIGHTS.

These resources are intended for skilled developers designing with TI products. You are solely responsible for (1) selecting the appropriate TI products for your application, (2) designing, validating and testing your application, and (3) ensuring your application meets applicable standards, and any other safety, security, regulatory or other requirements.

These resources are subject to change without notice. TI grants you permission to use these resources only for development of an application that uses the TI products described in the resource. Other reproduction and display of these resources is prohibited. No license is granted to any other TI intellectual property right or to any third party intellectual property right. TI disclaims responsibility for, and you will fully indemnify TI and its representatives against, any claims, damages, costs, losses, and liabilities arising out of your use of these resources.

TI's products are provided subject to [TI's Terms of Sale](#) or other applicable terms available either on [ti.com](https://www.ti.com) or provided in conjunction with such TI products. TI's provision of these resources does not expand or otherwise alter TI's applicable warranties or warranty disclaimers for TI products.

TI objects to and rejects any additional or different terms you may have proposed.

Mailing Address: Texas Instruments, Post Office Box 655303, Dallas, Texas 75265
Copyright © 2024, Texas Instruments Incorporated

Looking for pricing, stock, or lifecycle information?

Click below to explore more details on WIN SOURCE:

 [View TS3A4741DGKR on WIN SOURCE](#)

 [Texas Instruments](#) Information

Optimize Your Supply Chain with WIN SOURCE Solutions

-  Global Sourcing Solution
-  Obsolete Management
-  Cost Control Management
-  Shortage Management
-  Alternative Solution
-  Excess Inventory Management