



**THE DATASHEET OF  
MSA-0470**



## Data Sheet

### Description

The MSA-0470 is a high performance silicon bipolar Monolithic Microwave Integrated Circuit (MMIC) housed in a hermetic, high reliability package. This MMIC is designed for use as a general purpose 50Ω gain block. Typical applications include narrow and broad band IF and RF amplifiers in industrial and military applications.

The MSA-series is fabricated using Avago's 10 GHz  $f_T$ , 25 GHz  $f_{MAX}$ , silicon bipolar MMIC process which uses nitride self-alignment, ion implantation, and gold metallization to achieve excellent performance, uniformity and reliability. The use of an external bias resistor for temperature and current stability also allows bias flexibility.

### Features

- Cascadable 50Ω Gain Block
- 3 dB Bandwidth: DC to 4.0 GHz
- 12.5 dBm Typical P1 dB at 1.0 GHz
- 8.5 dB Typical Gain at 1.0 GHz
- Unconditionally Stable ( $k > 1$ )
- Hermetic Gold-ceramic Microstrip Package

### 70 mil Package

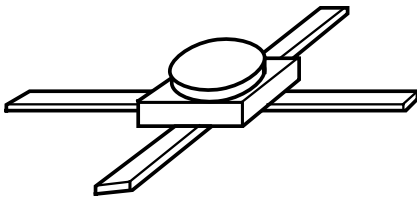

### Typical Biasing Configuration

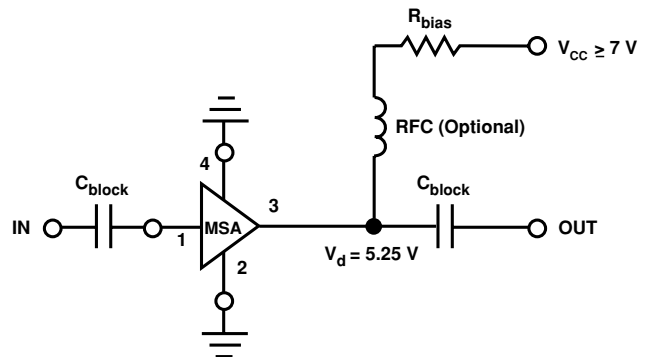

## MSA-0470 Absolute Maximum Ratings

Parameter	Absolute Maximum <sup>[1]</sup>
Device Current	100 mA
Power Dissipation <sup>[2,3]</sup>	650 mW
RF Input Power	+13 dBm
Junction Temperature	200°C
Storage Temperature	-65 to 200°C

Thermal Resistance<sup>[2,4]</sup>:

$$\theta_{jc} = 115^{\circ}\text{C/W}$$

Notes:

1. Permanent damage may occur if any of these limits are exceeded.
2.  $T_{\text{CASE}} = 25^{\circ}\text{C}$ .
3. Derate at 8.7 mW/°C for  $T_c > 125^{\circ}\text{C}$ .
4. The small spot size of this technique results in a higher, though more accurate determination of  $\theta_{jc}$  than do alternate methods.

## Electrical Specifications<sup>[1]</sup>, $T_A = 25^{\circ}\text{C}$

Symbol	Parameters and Test Conditions: $I_d = 50 \text{ mA}$ , $Z_0 = 50 \Omega$	Units	Min.	Typ.	Max.
$G_p$	Power Gain ( $ S_{21} ^2$ ) $f = 0.1 \text{ GHz}$	dB	7.5	8.5	9.5
$\Delta G_p$	Gain Flatness $f = 0.1 \text{ to } 2.5 \text{ GHz}$	dB		$\pm 0.6$	$\pm 1.0$
$f_{3 \text{ dB}}$	3 dB Bandwidth	GHz		4.0	
VSWR	Input VSWR $f = 0.1 \text{ to } 2.5 \text{ GHz}$			1.7:1	
	Output VSWR $f = 0.1 \text{ to } 2.5 \text{ GHz}$			2.0:1	
NF	50 $\Omega$ Noise Figure $f = 1.0 \text{ GHz}$	dB		6.5	
$P_{1 \text{ dB}}$	Output Power at 1 dB Gain Compression $f = 1.0 \text{ GHz}$	dBm		12.5	
$IP_3$	Third Order Intercept Point $f = 1.0 \text{ GHz}$	dBm		25.5	
$t_D$	Group Delay $f = 1.0 \text{ GHz}$	psec		125	
$V_d$	Device Voltage	V	4.75	5.25	5.75
$dV/dT$	Device Voltage Temperature Coefficient	mV/°C		-8.0	

Note:

1. The recommended operating current range for this device is 30 to 70 mA. Typical performance as a function of current is on the following page.

MSA-0470 Typical Scattering Parameters ( $Z_0 = 50 \Omega$ ,  $T_A = 25^\circ\text{C}$ ,  $I_d = 50 \text{ mA}$ )

Freq. GHz	$S_{11}$			$S_{21}$			$S_{12}$			$S_{22}$	
	Mag	Ang	dB	Mag	Ang	dB	Mag	Ang	Mag	Ang	
0.1	.18	179	8.5	2.67	176	-16.4	.151	1	.10	-14	
0.2	.18	179	8.5	2.67	172	-16.4	.151	2	.10	-30	
0.4	.18	179	8.5	2.67	163	-16.4	.152	3	.13	-50	
0.6	.17	-179	8.5	2.65	155	-16.2	.155	5	.16	-67	
0.8	.16	-176	8.4	2.64	147	-16.1	.158	8	.19	-79	
1.0	.16	-174	8.3	2.61	138	-15.9	.161	6	.22	-90	
1.5	.16	-166	8.2	2.56	117	-15.5	.169	9	.29	-111	
2.0	.21	-163	7.8	2.46	97	-14.6	.186	9	.33	-131	
2.5	.26	-162	7.3	2.33	83	-13.8	.204	12	.36	-142	
3.0	.32	-170	6.5	2.12	65	-13.5	.212	10	.40	-156	
3.5	.37	-177	5.7	1.93	38	-13.2	.220	7	.40	-164	
4.0	.40	175	4.7	1.73	33	-12.6	.234	3	.40	-170	
4.5	.41	166	3.9	1.57	20	-12.4	.239	-1	.39	-173	
5.0	.42	155	3.1	1.44	7	-11.9	.255	-6	.37	-176	

Typical Performance,  $T_A = 25^\circ\text{C}$  (unless otherwise noted)



Figure 1. Typical Power Gain vs. Frequency,  $T_A = 25^\circ\text{C}$ ,  $I_d = 50 \text{ mA}$ .

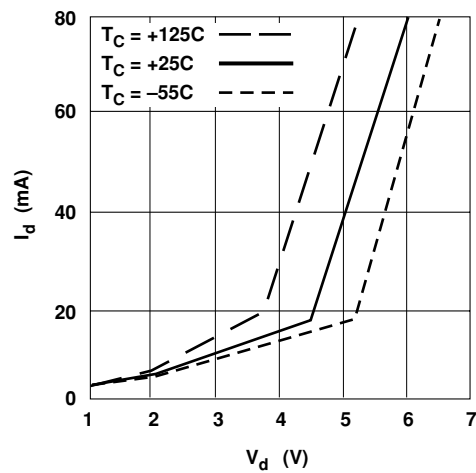

Figure 2. Device Current vs. Voltage.

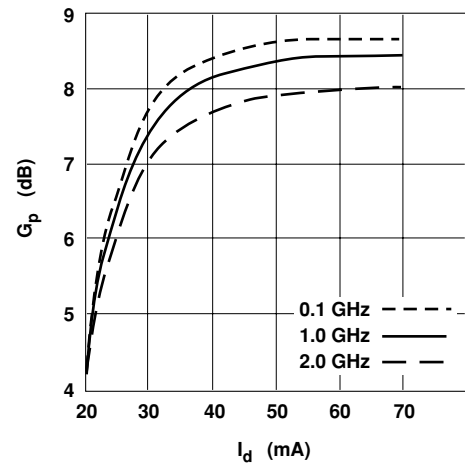

Figure 3. Power Gain vs. Current.

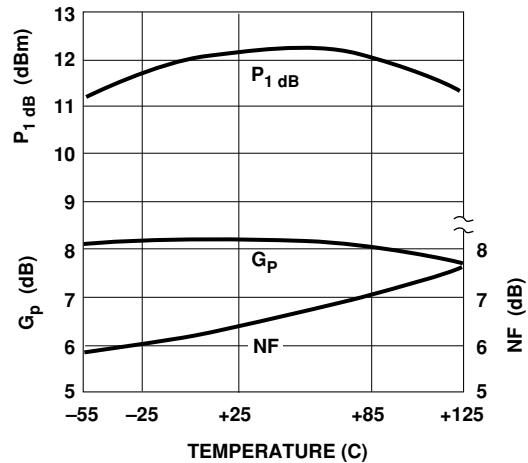

Figure 4. Output Power at 1 dB Gain Compression, NF and Power Gain vs. Case Temperature,  $f = 1.0 \text{ GHz}$ ,  $I_d = 50 \text{ mA}$ .

Typical Performance,  $T_A = 25^\circ\text{C}$  (unless otherwise noted)

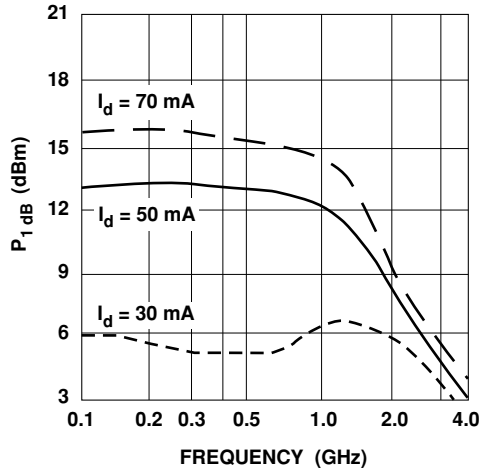

Figure 5. Output Power at 1 dB Gain Compression vs. Frequency.

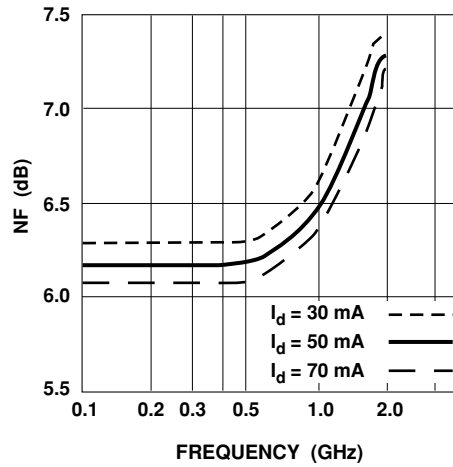
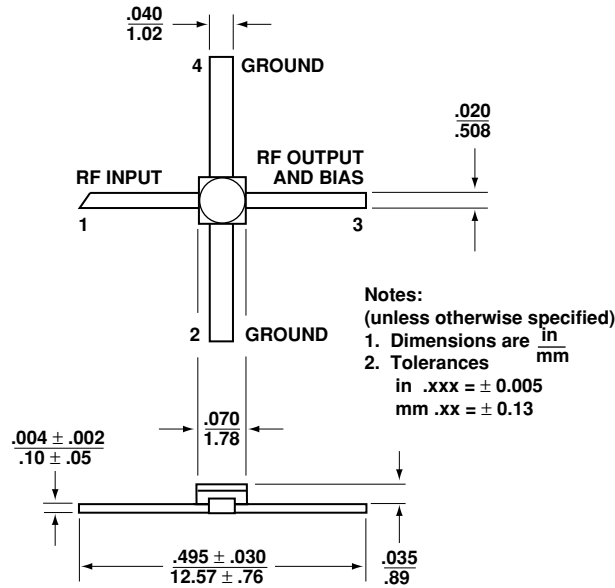

Figure 6. Noise Figure vs. Frequency.

Ordering Information

Part Numbers	No. of Devices	Comments
MSA-0470	100	Bulk

70 mil Package Dimensions



For product information and a complete list of distributors, please go to our web site: [www.avagotech.com](http://www.avagotech.com)

## Looking for pricing, stock, or lifecycle information?

Click below to explore more details on WIN SOURCE:

 [View MSA-0470 on WIN SOURCE](#)

 [Broadcom Limited](#) Information

## Optimize Your Supply Chain with WIN SOURCE Solutions

-  Global Sourcing Solution
-  Obsolete Management
-  Cost Control Management
-  Shortage Management
-  Alternative Solution
-  Excess Inventory Management