



**THE DATASHEET OF  
TL16CP754CIPM**



## TL16CP754C and TL16C754C – Quad UARTs With 64-Byte FIFO

Check for Samples: [TL16CP754C](#), [TL16C754C](#)

### FEATURES

- **ST16C654/654D Pin Compatible With Additional Enhancements**
- **Support up to:**
  - **24-MHz Crystal Input Clock (1.5 Mbps)**
  - **48-MHz Oscillator Input Clock (3 Mbps) for 5-V Operation**
  - **32-MHz Oscillator Input Clock (2 Mbps) for 3.3-V Operation**
  - **24-MHz Input Clock (1.5 Mbps) for 2.5-V Operation**
  - **16-MHz Input Clock (1 Mbps) for 1.8-V Operation**
- **64-Byte Transmit FIFO**
- **64-Byte Receive FIFO With Error Flags**
- **Programmable and Selectable Transmit and Receive FIFO Trigger Levels for DMA and Interrupt Generation**
- **Programmable Receive FIFO Trigger Levels for Software/Hardware Flow Control**
- **Software/Hardware Flow Control**
  - **Programmable Xon/Xoff Characters**
  - **Programmable Auto-RTS and Auto-CTS**
- **Optional Data Flow Resume by Xon Any Character**
- **RS-485 Mode Support**
- **Support 1.8-V, 2.5-V, 3.3-V, or 5-V Supply**
- **Characterized for Operation From –40°C to 85°C, Available in Commercial and Industrial Temperature Grades**
- **Software-Selectable Baud-Rate Generator**
- **Prescaler Provides Additional Divide-by-4 Function**
- **Programmable Sleep Mode**
- **Programmable Serial Interface Characteristics**
  - **5-, 6-, 7-, or 8-Bit Characters**
  - **Even, Odd, or No Parity Bit Generation and Detection**
  - **1-, 1.5-, or 2-Stop Bit Generation**
- **False Start Bit Detection**
- **Complete Status Reporting Capabilities in Both Normal and Sleep Mode**

- **Line Break Generation and Detection**
- **Internal Test and Loopback Capabilities**
- **Fully Prioritized Interrupt System Controls**
- **Modem Control Functions (CTS, RTS, DSR, DTR, RI, and CD)**
- **Infrared Data Association (IrDA) Capability**

### DESCRIPTION

The '754C is a quad universal asynchronous receiver transmitter (UART) with 64-byte FIFOs, automatic hardware and software flow control, and data rates up to 3 Mbps. It incorporates the functionality of four UARTs, each UART having its own register set and FIFOs. The four UARTs share only the data bus interface and clock source, otherwise they operate independently. Another name for the UART function is Asynchronous Communications Element (ACE), and these terms are used interchangeably. The bulk of this document describes the behavior of each ACE, with the understanding that four such devices are incorporated into the '754C. The '754C offers enhanced features. It has a transmission control register (TCR) that stores received FIFO threshold level to start or stop transmission during hardware and software flow control. With the FIFO RDY register, the software gets the status of TXRDY/RXRDY for all four ports in one access. On-chip status registers provide the user with error indications, operational status, and modem interface control. System interrupts may be tailored to meet user requirements. An internal loopback capability allows onboard diagnostics.

Each UART transmits data sent to it from the peripheral 8-bit bus on the TX signal and receives characters on the RX signal. Characters can be programmed to be 5, 6, 7, or 8 bits. The UART has a 64-byte receive FIFO and transmit FIFO and can be programmed to interrupt at different trigger levels. The UART generates its own desired baud rate based upon a programmable divisor and its input clock. It can transmit even, odd, or no parity and 1-, 1.5-, or 2-stop bits. The receiver can detect break, idle or framing errors, FIFO overflow, and parity errors. The transmitter can detect FIFO underflow. The UART also contains a software interface for modem control operations, and software flow control and hardware flow control capabilities.



Please be aware that an important notice concerning availability, standard warranty, and use in critical applications of Texas Instruments semiconductor products and disclaimers thereto appears at the end of this data sheet.

### DESCRIPTION (CONTINUED)

The '754C is available in a 64-pin TQFP PM package.  $\overline{\text{RXRDY}}$  and  $\overline{\text{TXRDY}}$  functionality is not supported in the TL16C754CPM device.

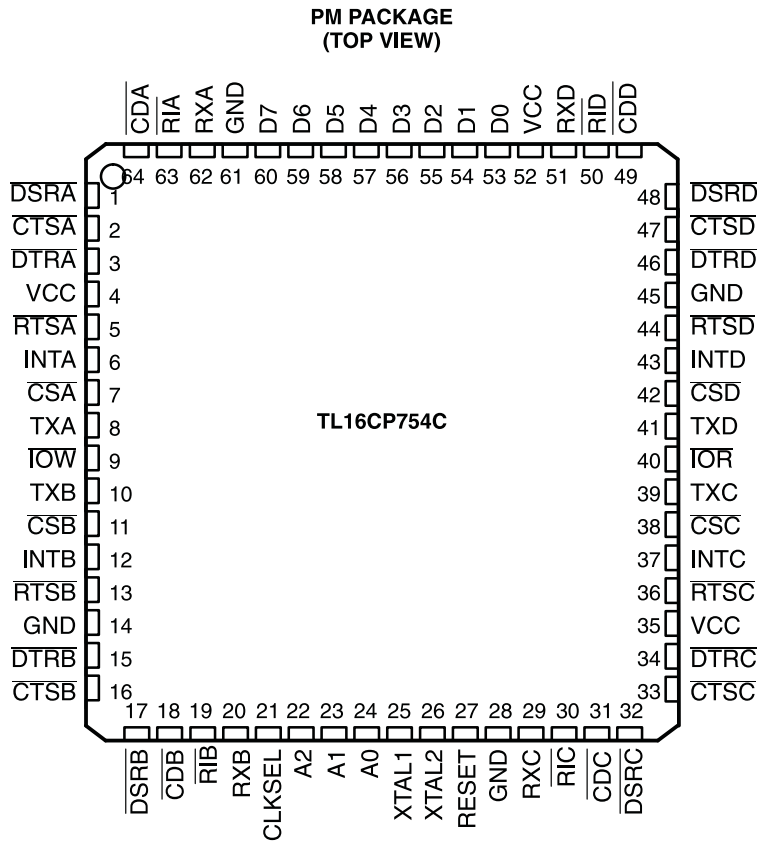

**Table 1. Terminal Functions**

TERMINAL		I/O	DESCRIPTION
NAME	NO.		
A0	24	I	Address bit 0 select. Internal registers address selection. Refer to <a href="#">Figure 22</a> for Register Address Map.
A1	23	I	Address bit 1 select. Internal registers address selection. Refer to <a href="#">Figure 22</a> for Register Address Map.
A2	22	I	Address bit 2 select. Internal registers address selection. Refer to <a href="#">Figure 22</a> for Register Address Map.
$\overline{\text{CDA}}$ , $\overline{\text{CDB}}$ , $\overline{\text{CDC}}$ , $\overline{\text{CDD}}$	64, 18, 31, 49	I	Carrier detect (active low). These inputs are associated with individual UART channels A through D. A low on these pins indicates that a carrier has been detected by the modem for that channel.
CLKSEL	21	I	Clock select. CLKSEL selects the divide-by-1 or divide-by-4 prescalable clock. During the reset, a logic 1 ( $V_{CC}$ ) on CLKSEL selects the divide-by-1 prescaler. A logic 0 (GND) on CLKSEL selects the divide-by-4 prescaler. The value of CLKSEL is latched into MCR[7] at the trailing edge of RESET. A logic 1 ( $V_{CC}$ ) on CLKSEL will latch a 0 into MCR[7]. A logic 0 (GND) on CLKSEL will latch a 1 into MCR[7]. MCR[7] can be changed after RESET to alter the prescaler value.
$\overline{\text{CSA}}$ , $\overline{\text{CSB}}$ , $\overline{\text{CSC}}$ , $\overline{\text{CSD}}$	7, 11, 38, 42	I	Chip select A, B, C, and D (active low). These pins enable data transfers between the user CPU and the '754C for the channel or channels addressed. Individual UART sections (A, B, C, D) are addressed by providing a low on the respective CSA through CSD pin.
$\overline{\text{CTSA}}$ , $\overline{\text{CTSB}}$ , $\overline{\text{CTSC}}$ , $\overline{\text{CTSD}}$	2, 16, 33, 47	I	Clear to send (active low). These inputs are associated with individual UART channels A through D. A low on the CTS pins indicates the modem or data set is ready to accept transmit data from the '754C. Status can be checked by reading MSR[4]. These pins only affect the transmit and receive operations when auto CTS function is enabled through the enhanced feature register (EFR[7]), for hardware flow control operation.

**Table 1. Terminal Functions (continued)**

TERMINAL		I/O	DESCRIPTION
NAME	NO.		
D0–D2, D3–D7	53–60	I/O	Data bus (bidirectional). These pins are the 8-bit, 3-state data bus for transferring information to or from the controlling CPU. D0 is the least significant bit and the first data bit in a transmit or receive serial data stream.
$\overline{\text{DSRA}}$ , $\overline{\text{DSRB}}$ , $\overline{\text{DSRC}}$ , $\overline{\text{DSRD}}$	1, 17, 32, 48	I	Data set ready (active low). These inputs are associated with individual UART channels A through D. A low on these pins indicates the modem or data set is powered on and is ready for data exchange with the UART.
$\overline{\text{DTRA}}$ , $\overline{\text{DTRB}}$ , $\overline{\text{DTRC}}$ , $\overline{\text{DTRD}}$	3, 15, 34, 46	O	Data terminal ready (active low). These outputs are associated with individual UART channels A through D. A low on these pins indicates that the '754C is powered on and ready. These pins can be controlled through the modem control register. Writing a 1 to MCR[0] sets the DTR output to low, enabling the modem. The output of these pins is high after writing a 0 to MCR[0], or after a reset. These pins can also be used in the RS-485 mode to control an external RS-485 driver or transceiver.
GND	14, 28, 45, 61	Pwr	Power signal and power ground
INTA, INTB, INTC, INTD	6, 12, 37, 43	O	Interrupt A, B, C, and D (active high). These pins provide individual channel interrupts, INTA–D. INTA–D are enabled when MCR[3] is set to a 1, interrupts are enabled in the interrupt enable register (IER) and when an interrupt condition exists. Interrupt conditions include: receiver errors, available receiver buffer data, transmit buffer empty, or when a modem status flag is detected. INTA–D are in the high-impedance state after reset.
INTSEL	–	I	Interrupt select (active high with internal pulldown). INTSEL can be used in conjunction with MCR[3] to enable or disable the 3-state interrupts INTA–D or override MCR[3] and force continuous interrupts. Interrupt outputs are enabled continuously by making this pin a 1. Driving this pin low allows MCR[3] to control the 3-state interrupt output. In this mode, MCR[3] is set to a 1 to enable the 3-state outputs.
$\overline{\text{IOR}}$	40	I	Read input (active low strobe). A valid low level on $\overline{\text{IOR}}$ loads the contents of an internal register defined by address bits A0 through A2 onto the '754C data bus (D0 through D7) for access by an external CPU.
$\overline{\text{IOW}}$	9	I	Write input (active low strobe). A valid low level on $\overline{\text{IOW}}$ transfers the contents of the data bus (D0 through D7) from the external CPU to an internal register that is defined by address bits A0 through A2.
RESET	27	I	Reset. RESET resets the internal registers and all the outputs. The UART transmitter output and the receiver input are disabled during reset time. See '754C external reset conditions for initialization details. RESET is an active high input.
$\overline{\text{RIA}}$ , $\overline{\text{RIB}}$ , $\overline{\text{RIC}}$ , $\overline{\text{RID}}$	63, 19, 30, 50	I	Ring indicator (active low). These inputs are associated with individual UART channels A through D. A low on these pins indicates the modem has received a ringing signal from the telephone line. A low-to-high transition on these input pins generates a modem status interrupt, if it is enabled.
$\overline{\text{RTSA}}$ , $\overline{\text{RTSB}}$ , $\overline{\text{RTSC}}$ , $\overline{\text{RTSD}}$	5, 13, 36, 44	O	Request to send (active low). These outputs are associated with individual UART channels A through D. A low on the $\overline{\text{RTS}}$ pins indicates the transmitter has data ready and waiting to send. Writing a 1 in the modem control register (MCR[1]) sets these pins to low, indicating data is available. After a reset, these pins are set to 1. These pins only affect the transmit and receive operation when auto- $\overline{\text{RTS}}$ function is enabled through the enhanced feature register (EFR[6]), for hardware flow control operation.
RXA, RXB, RXC, RXD	62, 20, 29, 51	I	Receive data input. These inputs are associated with individual serial channel data to the '754C. During the local loopback mode, these RX input pins are disabled and TX data is internally connected to the UART RX input internally. During normal mode, RXn should be held high when no data is being received. These outputs also can be used in IrDA mode. For more information, see <a href="#">IrDA Overview</a> .
$\overline{\text{RXRDY}}^{(1)}$	–	O	Receive ready (active low). RXRDY contains the wire-ORed status of all four receive channel FIFOs, RXRDY A–D. It goes low when the trigger level has been reached or a timeout interrupt occurs. It goes high when all RX FIFOs are empty and there is an error in RX FIFO.

(1)  $\overline{\text{RXRDY}}$  and  $\overline{\text{TXRDY}}$  functionality is not supported in the TL16C754CPM device.

**Table 1. Terminal Functions (continued)**

TERMINAL		I/O	DESCRIPTION
NAME	NO.		
TXA, TXB, TXC, TXD	8, 10, 39, 41	O	Transmit data. These outputs are associated with individual serial transmit channel data from the '754C. During the local loopback mode, the TX input pin is disabled and TX data is internally connected to the UART RX input. During normal mode, TXn is high when no data is being sent. These outputs can also be used in IrDA mode, in which case TXn is low when no data is being sent. For more information, see <a href="#">IrDA Overview</a> .
$\overline{\text{TXRDY}}^{(2)}$	–	O	Transmit ready (active low). $\overline{\text{TXRDY}}$ contains the wire-ORed status of all four transmit channel FIFOs, TXRDY A–D. It goes low when there are a trigger level number of spares available. It goes high when all four TX buffers are full.
V <sub>CC</sub>	4, 35, 52	Pwr	Power supply inputs
XTAL1	25	I	Crystal or external clock input. XTAL1 functions as a crystal input or as an external clock input. A crystal can be connected between XTAL1 and XTAL2 to form an internal oscillator circuit (see <a href="#">Figure 8</a> ). Alternatively, an external clock can be connected to XTAL1 to provide custom data rates.
XTAL2	26	O	Output of the crystal oscillator or buffered clock. See also XTAL1. XTAL2 is used as a crystal oscillator output or buffered clock output.

(2)  $\overline{\text{RXRDY}}$  and  $\overline{\text{TXRDY}}$  functionality is not supported in the TL16C754CPM device.

Functional Block Diagram

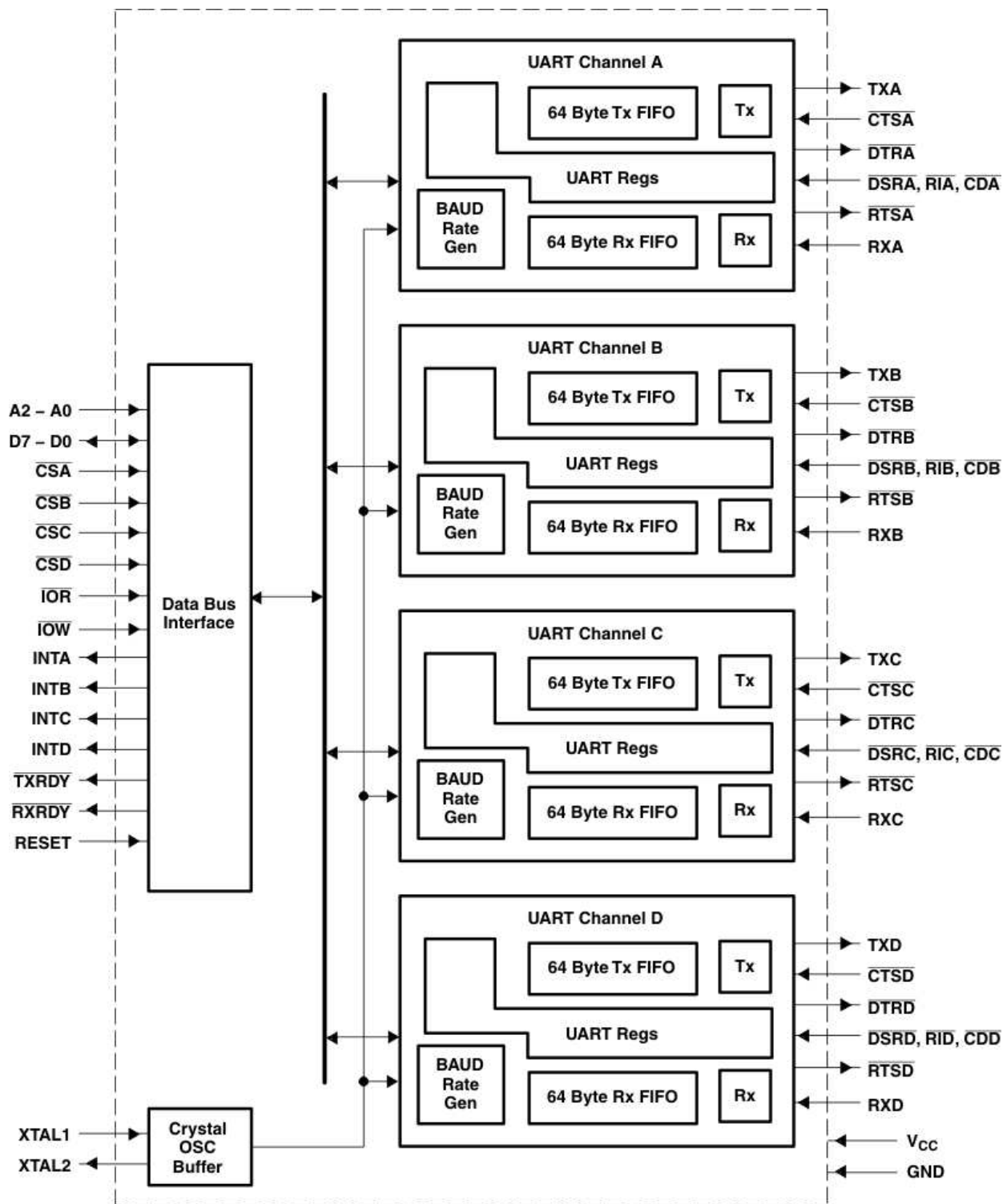

NOTE:  $\overline{\text{RXRDY}}$  and  $\overline{\text{TXRDY}}$  functionality is not supported in the TL16C754CPM device.

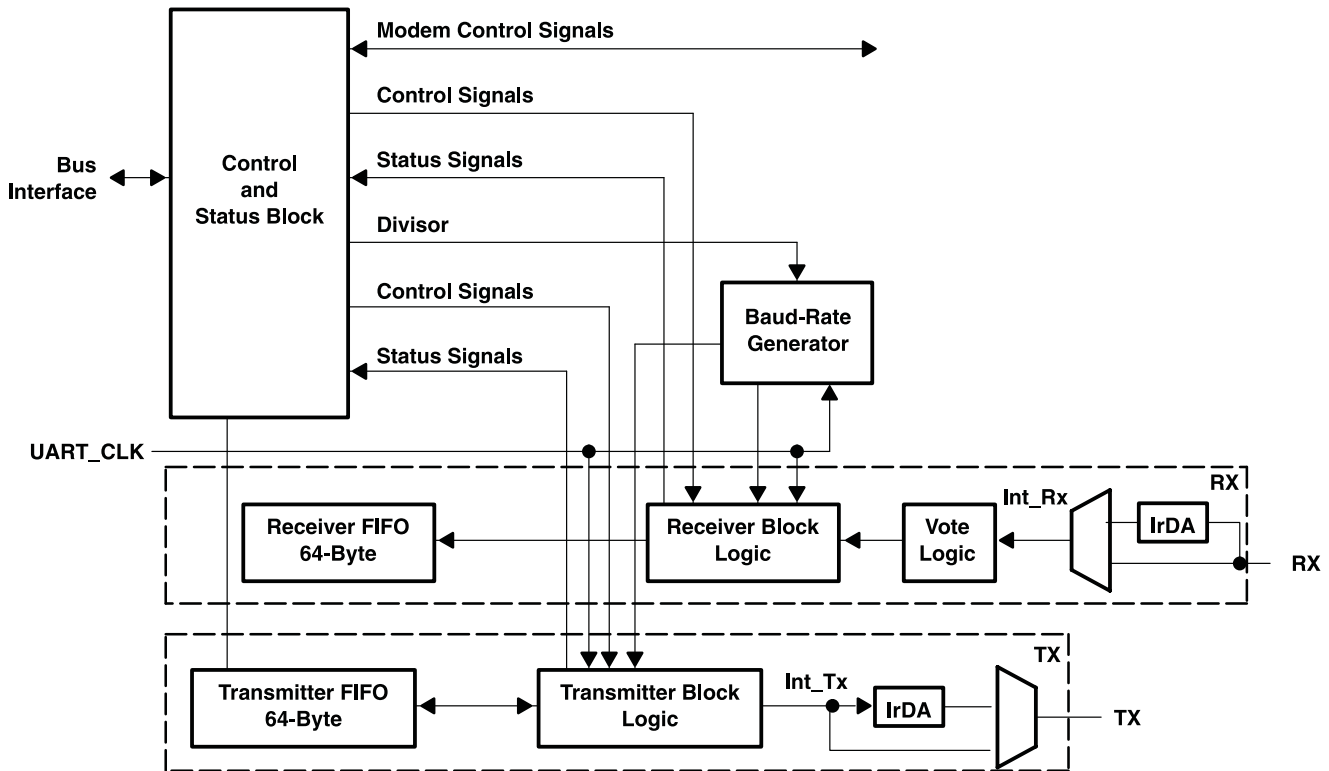

A. The vote logic determines whether the RX data is a logic 1 or 0. It takes three samples of the RX line and uses a majority vote to determine the logic level received. The vote logic operates on all bits received.

### Functional Description

The '754C UART is pin compatible with the TL16C754B and ST16C654 UARTs. It provides more enhanced features. All additional features are provided through a special enhanced feature register.

The UART performs serial-to-parallel conversion on data characters received from peripheral devices or modems and parallel-to-parallel conversion on data characters transmitted by the processor. The complete status of each channel of the '754C UART can be read at any time during functional operation by the processor.

The '754C UART can be placed in an alternate mode (FIFO mode) relieving the processor of excessive software overhead by buffering received and transmitted characters. Both the receiver and transmitter FIFOs can store up to 64 bytes (including three additional bits of error status per byte for the receiver FIFO) and have selectable or programmable trigger levels. Primary outputs RXRDY and TXRDY allow Signaling of DMA transfers.

The '754C UART has selectable hardware flow control and software flow control. Both schemes significantly reduce software overhead and increase system efficiency by automatically controlling serial data flow. Hardware flow control uses the  $\overline{RTS}$  output and  $\overline{CTS}$  input signals. Software flow control uses programmable Xon and Xoff characters.

The UART includes a programmable baud rate generator that can divide the timing reference clock input by a divisor between 1 and  $(2^{16}-1)$ . The CLKSEL pin can be used to divide the input clock by 4 or by 1 to generate the reference clock during the reset. The divide-by-4 clock is selected when CLKSEL pin is a logic 0 or the divide-by-1 is selected when CLKSEL is a logic 1.

### Trigger Levels

The '754C UART provides independent selectable and programmable trigger levels for both receiver and transmitter DMA and interrupt generation. After reset, both transmitter and receiver FIFOs are disabled and so, in effect, the trigger level is the default value of one byte. The selectable trigger levels are available through the FCR. The programmable trigger levels are available through the TLR.

## Hardware Flow Control

Hardware flow control is composed of auto- $\overline{\text{CTS}}$  and auto- $\overline{\text{RTS}}$ . Auto- $\overline{\text{CTS}}$  and auto- $\overline{\text{RTS}}$  can be enabled or disabled independently by programming EFR[7:6].

With auto- $\overline{\text{CTS}}$ ,  $\overline{\text{CTS}}$  must be active before the UART can transmit data. Auto- $\overline{\text{RTS}}$  only activates the  $\overline{\text{RTS}}$  output when there is enough room in the FIFO to receive data and deactivates the  $\overline{\text{RTS}}$  output when the RX FIFO is sufficiently full. The HALT and RESTORE trigger levels in the TCR determine the levels at which  $\overline{\text{RTS}}$  is activated or deactivated. If both auto- $\overline{\text{CTS}}$  and auto- $\overline{\text{RTS}}$  are enabled, when  $\overline{\text{RTS}}$  is connected to  $\overline{\text{CTS}}$ , data transmission does not occur unless the receiver FIFO has empty space. Thus, overrun errors are eliminated during hardware flow control. If not enabled, overrun errors occur if the transmit data rate exceeds the receive FIFO servicing latency.

### Auto- $\overline{\text{RTS}}$

Auto- $\overline{\text{RTS}}$  data flow control originates in the receiver block (see ). Figure 1 shows  $\overline{\text{RTS}}$  functional timing. The receiver FIFO trigger levels used in Auto- $\overline{\text{RTS}}$  are stored in the TCR.  $\overline{\text{RTS}}$  is active if the RX FIFO level is below the HALT trigger level in TCR[3:0]. When the receiver FIFO HALT trigger level is reached,  $\overline{\text{RTS}}$  is deasserted. The sending device (for example, another UART) may send an additional byte after the trigger level is reached (assuming the sending UART has another byte to send) because it may not recognize the deassertion of  $\overline{\text{RTS}}$  until it has begun sending the additional byte.  $\overline{\text{RTS}}$  is automatically reasserted once the receiver FIFO reaches the RESUME trigger level programmed via TCR[7:4]. This reassertion allows the sending device to resume transmission.

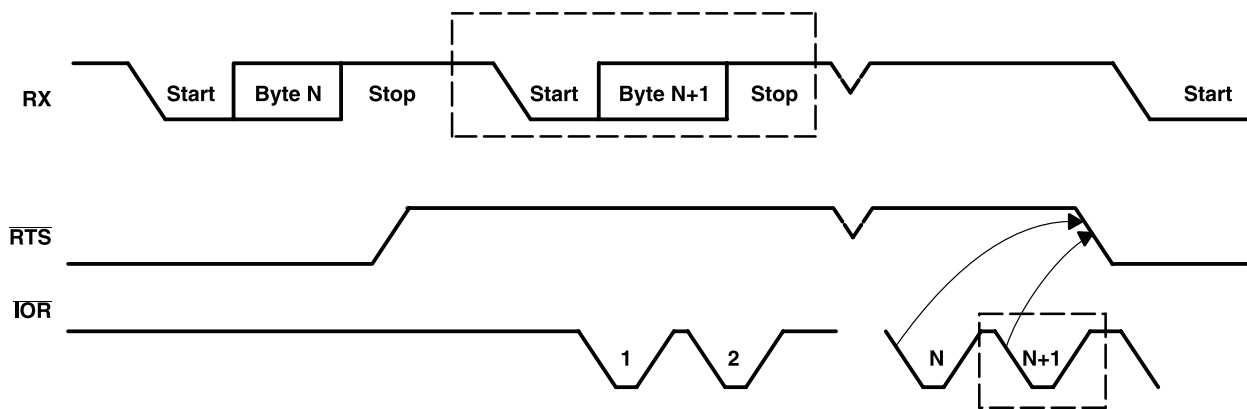

- A. N = receiver FIFO trigger level B.
- B. The two blocks in dashed lines cover the case where an additional byte is sent as described in Auto- $\overline{\text{RTS}}$ .

Figure 1.  $\overline{\text{RTS}}$  Functional Timing

### Auto- $\overline{\text{CTS}}$

The transmitter circuitry checks  $\overline{\text{CTS}}$  before sending the next data byte. When  $\overline{\text{CTS}}$  is active, the transmitter sends the next byte. To stop the transmitter from sending the following byte,  $\overline{\text{CTS}}$  must be deasserted before the middle of the last stop bit that is currently being sent. The auto- $\overline{\text{CTS}}$  function reduces interrupts to the host system. When flow control is enabled, the  $\overline{\text{CTS}}$  state changes and need not trigger host interrupts because the device automatically controls its own transmitter. Without auto- $\overline{\text{CTS}}$ , the transmitter sends any data present in the transmit FIFO and a receiver overrun error can result. Figure 2 shows  $\overline{\text{CTS}}$  functional timing, and Figure 3 shows an example of autoflow control.

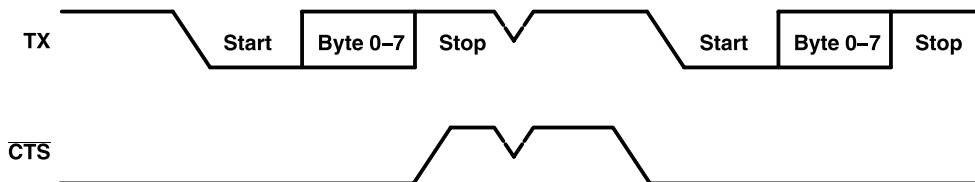

- A. When  $\overline{\text{CTS}}$  is low, the transmitter keeps sending serial data out.
- B. When  $\overline{\text{CTS}}$  goes high before the middle of the last stop bit of the current byte, the transmitter finishes sending the current byte, but it does not send the next byte.
- C. When  $\overline{\text{CTS}}$  goes from high to low, the transmitter begins sending data again.

Figure 2.  $\overline{\text{CTS}}$  Functional Timing

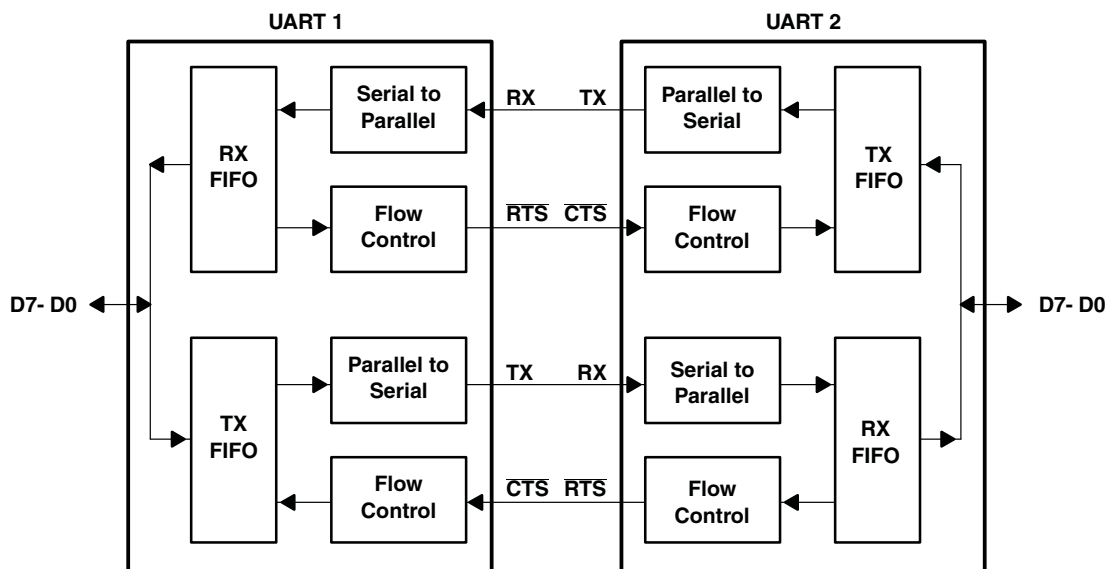

Figure 3. Autoflow Control (Auto-RTS and Auto-CTS) Example

**Software Flow Control**

Software flow control is enabled through the enhanced feature register and the modem control register. Different combinations of software flow control can be enabled by setting different combinations of EFR[3-0]. Table 2 shows software flow control options.

Two other enhanced features relate to software flow control:

- **Xon Any Function [MCR(5)]:** Operation resumes after receiving any character after recognizing the Xoff character.

**NOTE**

It is possible that an Xon1 character is recognized as an Xon Any character, which could cause an Xon2 character to be written to the RX FIFO.

- **Special Character [EFR(5)]:** Incoming data is compared to Xoff2. Detection of the special character sets the Xoff interrupt (IIR(4)) but does not halt transmission. The Xoff interrupt is cleared by a read of the IIR. The special character is transferred to the RX FIFO.

**Table 2. Software Flow Control Options EFR[3:0]**

BIT 3	BIT 2	BIT 1	BIT 0	Tx, Rx SOFTWARE FLOW CONTROLS
0	0	X	X	No transmit flow control
1	0	X	X	Transmit Xon1, Xoff1
0	1	X	X	Transmit Xon2, Xoff2
1	1	X	X	Transmit Xon1, Xon2: Xoff1, Xoff2
X	X	0	0	No receive flow control
X	X	1	0	Receiver compares Xon1, Xoff1 X X 0 1
X	X	0	1	Receiver compares Xon2, Xoff2
1	0	1	1	Transmit Xon1, Xoff1 Receiver compares Xon1 or Xon2, Xoff1 or Xoff2
0	1	1	1	Transmit Xon2, Xoff2 Receiver compares Xon1 or Xon2, Xoff1 or Xoff2
1	1	1	1	Transmit Xon1, Xon2: Xoff1, Xoff2 Receiver compares Xon1 and Xon2: Xoff1 and Xoff2
0	0	1	1	No transmit flow control Receiver compares Xon1 and Xon2: Xoff1 and Xoff2

When software flow control operation is enabled, the '754C compares incoming data with Xoff1/2 programmed characters (in certain cases Xoff1 and Xoff2 must be received sequentially <sup>(1)</sup>). When an Xoff character is received, transmission is halted after completing transmission of the current character. Xoff character detection also sets IIR[4] and causes INT to go high (if enabled via IER[5]).

To resume transmission an Xon1/2 character must be received (in certain cases Xon1 and Xon2 must be received sequentially). When the correct Xon characters are received IIR[4] is cleared and the Xoff interrupt disappears.

---

**NOTE**

If a parity, framing, or break error occurs while receiving a software flow control character, this character is treated as normal data and is written to the RCV FIFO.

---

Xoff1 and Xoff2 characters are transmitted when the RX FIFO has passed the programmed trigger level TCR[3:0].

Xon1 and Xon2 characters are transmitted when the RX FIFO reaches the trigger level programmed via TCR[7:4].

---

**NOTE**

If, after an Xoff character has been sent, software flow control is disabled, the UART transmits Xon characters automatically to enable normal transmission to proceed. A feature of the '754C UART design is that if the software flow combination (EFR[3:0]) changes after an Xoff has been sent, the originally programmed Xon is automatically sent. If the RX FIFO is still above the trigger level, the newly programmed Xoff1 or Xoff2 is transmitted.

---

The transmission of Xoff and Xon follows the exact same protocol as transmission of an ordinary byte from the FIFO. This means that even if the word length is set to be 5, 6, or 7 characters, then the 5, 6, or 7 least significant bits of Xoff1, Xoff2 and Xon1, Xon2 are transmitted. The transmission of 5, 6, or 7 bits of a character is seldom done, but this functionality is included to maintain compatibility with earlier designs.

It is assumed that software flow control and hardware flow control are never enabled simultaneously. [Figure 4](#) shows a software flow control example.

(1) When pairs of Xon/Xoff characters are programmed to occur sequentially, received Xon1/Xoff1 characters will be written to the Rx FIFO if the subsequent character is not Xon2/Xoff2.

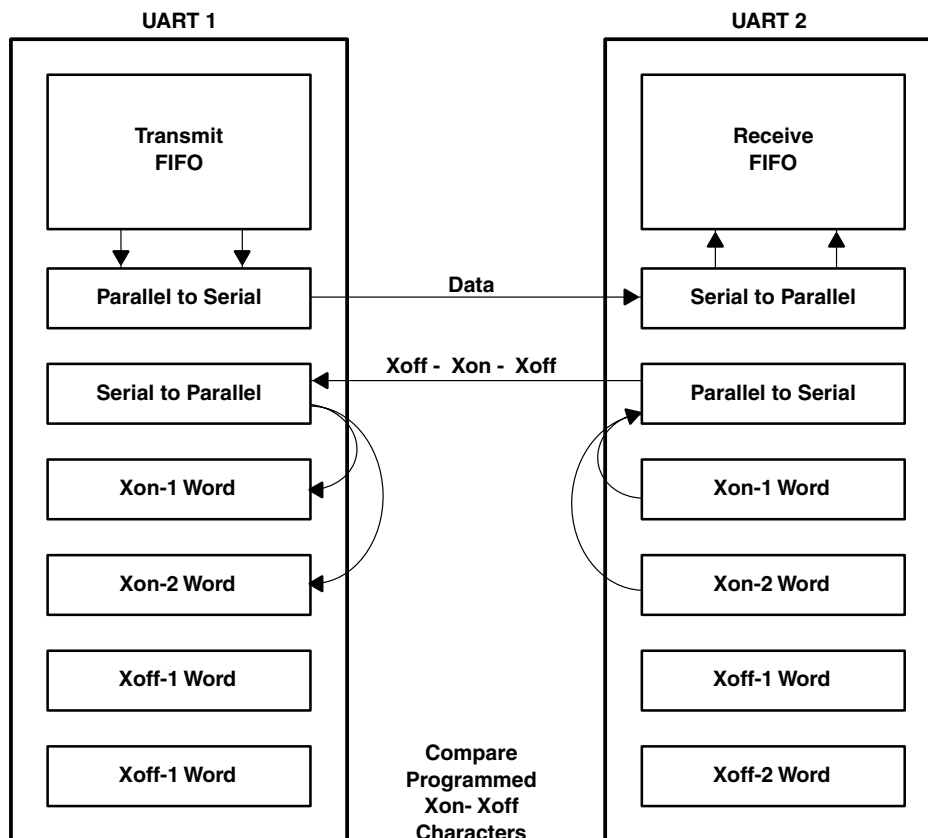

Figure 4. Software Flow Control Example

**Software Flow Control Example**

Assumptions: UART1 is transmitting a large text file to UART2. Both UARTs are using software flow control with single character Xoff (0F) and Xon (0D) tokens. Both have Xoff threshold (TCR [3:0]=F) set to 60 and Xon threshold (TCR[7:4]=8) set to 32. Both have the interrupt receive threshold (TLR[7:4]=D) set to 52.

UART1 begins transmission and sends 52 characters, at which point UART2 generates an interrupt to its processor to service the RCV FIFO, but assumes the interrupt latency is fairly long. UART1 continues sending characters until a total of 60 characters have been sent. At this time UART2 transmits a 0F to UART1, informing UART1 to halt transmission. UART1 likely sends the 61<sup>st</sup> character while UART2 is sending the Xoff character. Now UART2 is serviced and the processor reads enough data out of the RCV FIFO that the level drops to 32. UART2 now sends a 0D to UART1, informing UART1 to resume transmission.

**Reset**

Table 3 summarizes the state of outputs after reset.

**Table 3. Register Reset Functions<sup>(1)</sup>**

REGISTER	RESET CONTROL	RESET STATE
Interrupt enable register	RESET	All bits cleared
Interrupt identification register	RESET	Bit 0 is set. All other bits cleared.
FIFO control register	RESET	All bits cleared
Line control register	RESET	Reset to 00011101 (1D hex)
Modem control register	RESET	Bit 6–0 cleared. Bit 7 reflects the inverse of the CLKSEL pin value.
Line status register	RESET	Bits 5 and 6 set. All other bits cleared.
Modem status register	RESET	Bits 0–3 cleared. Bits 4–7 input signals.
Enhanced feature register	RESET	Bit 6–0 is cleared. Bit 7 reflects the inverse of the CLKSEL pin value.
Receiver holding register	RESET	Pointer logic cleared
Transmitter holding register	RESET	Pointer logic cleared
Transmission control register	RESET	All bits cleared
Trigger level register	RESET	All bits cleared
Alternate function register	RESET	All bits (except AFR4) cleared; AFR4 set

(1) Registers DLL, DLH, SPR, Xon1, Xon2, Xoff1, and Xoff2 are not reset by the top-level reset signal RESET, that is, they hold their initialization values during reset.

Table 4 summarizes the state of outputs after reset.

**Table 4. Signal Reset Functions**

SIGNAL	RESET CONTROL	RESET STATE
TX	RESET	High
$\overline{\text{RTS}}$	RESET	High
$\overline{\text{DTR}}$	RESET	High
$\overline{\text{RXRDY}}$	RESET	High
$\overline{\text{TXRDY}}$	RESET	Low

## Interrupts

The '754C UART has interrupt generation and prioritization (six prioritized levels of interrupts) capability. The interrupt enable register (IER) enables each of the six types of interrupts and the INT signal in response to an interrupt generation. The IER also can disable the interrupt system by clearing bits 0 to 3, 5 to 7. When an interrupt is generated, the interrupt identification register (IIR) indicates that an interrupt is pending and provides the type of interrupt through IIR[5–0]. Table 5 summarizes the interrupt control functions.

**Table 5. Interrupt Control Functions**

IIR[5–0]	PRIORITY LEVEL	INTERRUPT TYPE	INTERRUPT SOURCE	INTERRUPT RESET METHOD
000001	None	None	None	None
000110	1	Receiver line status	OE, FE, PE, or BI errors occur in characters in the RX FIFO	FE < PE < BI: All erroneous characters are read from the RX FIFO. OE: Read LSR
001100	2	RX timeout	Stale data in RX FIFO	Read RHR
000100	2	RHR interrupt	DRDY (data ready) (FIFO disable) RX FIFO above trigger level (FIFO enable)	Read RHR
000010	3	THR interrupt	TFE (THR empty) (FIFO disable) TX FIFO passes above trigger level (FIFO enable)	Read IIR OR a write to the THR
000000	4	Modem status	MSR[3:0]= 0	Read MSR
010000	5	Xoff interrupt	Receive Xoff character(s)/special character	Receive Xon character(s)/Read of IIR
100000	6	$\overline{\text{CTS}}$ , $\overline{\text{RTS}}$	$\overline{\text{RTS}}$ pin or $\overline{\text{CTS}}$ pin change state from active (low) to inactive (high)	Read IIR

It is important to note that for the framing error, parity error, and break conditions, LSR[7] generates the interrupt. LSR[7] is set when there is an error anywhere in the RX FIFO and is cleared only when there are no more errors remaining in the FIFO. LSR[4–2] always represent the error status for the received character at the top of the Rx FIFO. Reading the Rx FIFO updates LSR[4–2] to the appropriate status for the new character at the top of the FIFO. If the Rx FIFO is empty, then LSR[4–2] is all 0.

For the Xoff interrupt, if an Xoff flow character detection caused the interrupt, the interrupt is cleared by an Xon flow character detection. If a special character detection caused the interrupt, the interrupt is cleared by a read of the ISR.

**Interrupt Mode Operation**

In interrupt mode (if any bit of IER[3:0] is 1), the processor is informed of the status of the receiver and transmitter by an interrupt signal, INT. Therefore, it is not necessary to continuously poll the line status register (LSR) to see if any interrupt needs to be serviced. Figure 5 shows interrupt mode operation.

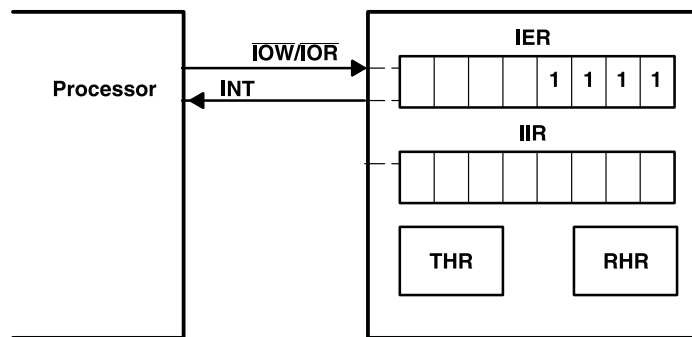

**Figure 5. Interrupt Mode Operation**

**Polled Mode Operation**

In polled mode (IER[3:0] = 0000), the status of the receiver and transmitter can then be checked by polling the line status register (LSR). This mode is an alternative to the interrupt mode of operation where the status of the receiver and transmitter is automatically known by means of interrupts sent to the CPU. Figure 6 shows polled mode operation.

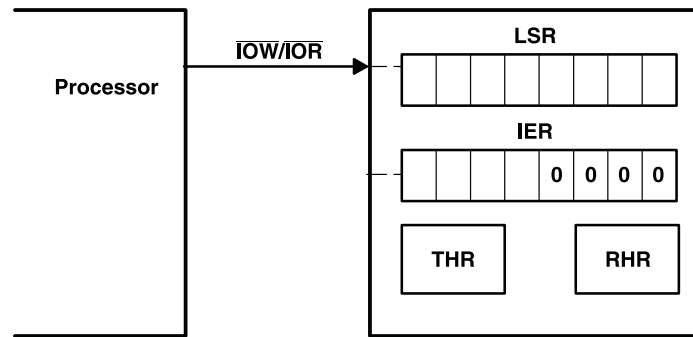

Figure 6. FIFO Polled Mode Operation

### DMA Signaling

There are two modes of DMA operation, DMA mode 0 or 1. Bit 3 of the FIFO control register, FCR[3], selects the DMA mode.

In DMA mode 0 or FIFO disable mode (FCR[0] = 0), DMA occurs in single character transfers. In DMA mode 1, multicharacter (or block) DMA transfers are managed to relieve the processor for longer periods of time.

#### Single DMA Transfers (DMA Mode0/FIFO Disable)

The ACE transmitter logic handles characters one at a time and transmits each time a character is written to the THR.

#### Block DMA Transfers (DMA Mode1)

The transmitter does not transmit data until a trigger level number of spaces is available in the FIFO. Bits 4 and 5 of the FIFO control register, FCR[5:4], select the trigger level. Bits 7 and 6 of the FIFO control register, FCR[7:6] set the trigger level for the receive FIFO.

### Sleep Mode

Sleep mode is an enhanced feature of the '754C UART. It is enabled when EFR[4], the enhanced functions bit, is set and when IER[4] is set. Sleep mode is entered when:

- The serial data input line, RX, is idle (see break and timeout conditions).
- The TX FIFO and TX shift register are empty.
- There are no interrupts pending except THR and timeout interrupts.

Sleep mode is not entered if there is data in the RX FIFO.

In sleep mode, the UART clock and baud rate clock are stopped. Because most registers are clocked using these clocks, the power consumption is greatly reduced. The UART wakes up when any change is detected on the RX line, when there is any change in the state of the modem input pins, or if data is written to the TX FIFO.

#### NOTE

Writing to the divisor latches, DLL and DLH, to set the baud clock, must not be done during sleep mode. Therefore, TI recommends to disable sleep mode using IER[4] before writing to DLL or DLH.

### Break and Timeout Conditions

An RX timeout condition is detected when the receiver line, RX, has been high for a time equivalent to (4 x programmed word length) + 12 bits and there is at least one byte stored in the Rx FIFO.

When a break condition occurs, the TX line is pulled low. A break condition is activated by setting LCR[6].

## Programmable Baud Rate Generator

The '754C UART contains a programmable baud generator that divides reference clock by a divisor in the range between 1 and (216–1). The output frequency of the baud rate generator is 16x the baud rate. An additional divide-by-4 prescaler is also available and can be selected by the CLKSEL pin or MCR[7], as shown in the following. The formula for the divisor is:

$$\text{Divisor} = (\text{XTAL crystal input frequency} / \text{prescaler}) / (\text{desired baud rate} \times 16)$$

Where

$$\text{prescaler} = \begin{cases} 1 & \text{when CLKSEL} = \text{high during reset, or MCR}[7] \text{ is set to 0 after reset} \\ 4 & \text{when CLKSEL} = \text{low during reset, or MCR}[7] \text{ is set to 1 after reset} \end{cases}$$

Figure 7 shows the internal prescaler and baud rate generator circuitry.

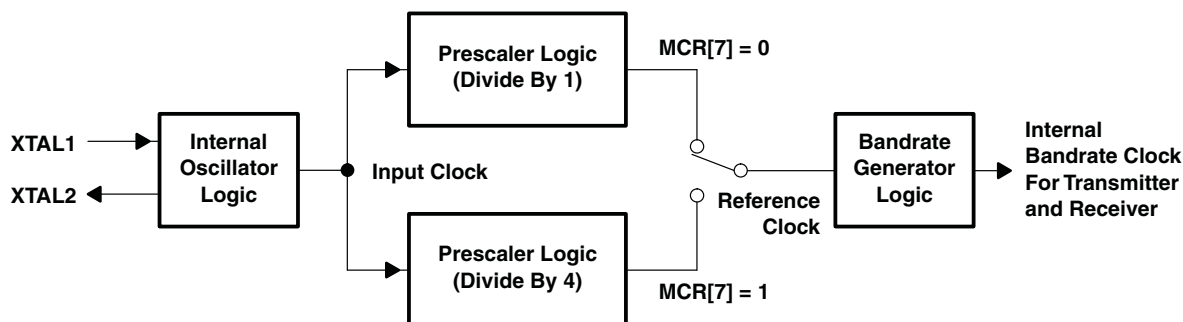

Figure 7. Prescaler and Baud Rate Generator Block Diagram

DLL and DLH must be written to in order to program the baud rate. DLL and DLH are the least significant and most significant byte of the baud rate divisor. If DLL and DLH are both 0, the UART is effectively disabled, because no baud clock is generated. The programmable baud rate generator is provided to select both the transmit and receive clock rates. Table 6 and Table 7 show the baud rate and divisor correlation for the crystal with frequency 1.8432 MHz and 3.072 MHz, respectively.

**Table 6. Baud Rates Using a 1.8432-MHz Crystal**

DESIRED BAUD RATE	DIVISOR USED TO GENERATE 16x CLOCK	PERCENT ERROR DIFFERENCE BETWEEN DESIRED AND ACTUAL
50	2304	
75	1536	
110	1047	0.026
134.5	857	0.058
150	768	
300	384	
600	192	
1200	96	
1800	64	
2000	58	0.69
2400	48	
3600	32	
4800	24	
7200	16	
9600	12	
19200	6	
38400	3	
56000	2	2.86

**Table 7. Baud Rates Using a 3.072-MHz Crystal**

DESIRED BAUD RATE	DIVISOR USED TO GENERATE 16x CLOCK	PERCENT ERROR DIFFERENCE BETWEEN DESIRED AND ACTUAL
50	3840	
75	2560	
110	1745	0.026
134.5	1428	0.034
150	1280	
300	640	
600	320	
1200	160	
1800	107	0.312
2000	96	
2400	80	
3600	53	0.628
4800	40	
7200	27	1.23
9600	20	
19200	10	
38400	5	

Figure 8 shows the crystal clock circuit reference.

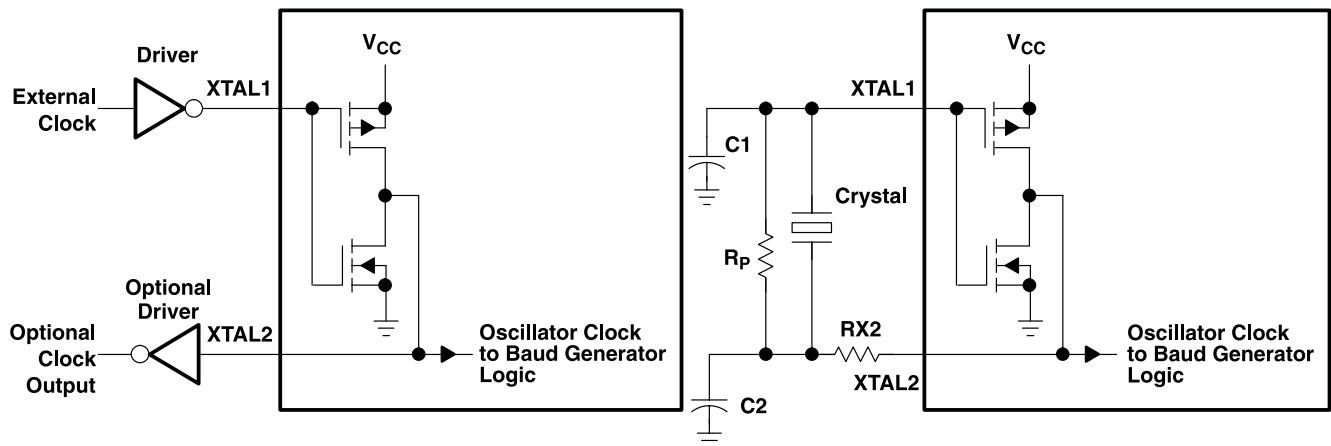

TYPICAL CRYSTAL OSCILLATOR NETWORK

CRYSTAL	R <sub>p</sub>	RX2	C1	C2
16 MHz	1 MΩ	0	33 pF	33 pF
3.072 MHz	1 MΩ	1.5 kΩ	10–30 pF	40–60 pF
1.8432 MHz	1 MΩ	1.5 kΩ	10–30 pF	40–60 pF

- A. For crystal with fundamental frequency from 1 to 24 MHz
- B. For input clock frequency higher than 24 MHz, the crystal is not allowed and the oscillator must be used, because the '754C internal oscillator cell can only support the crystal frequency up to 24 MHz.

Figure 8. Typical Crystal Clock Circuits

### Absolute Maximum Ratings<sup>(1)</sup>

over operating free-air temperature range (unless otherwise noted)

PARAMETER		MIN	MAX	UNIT		
V <sub>CC</sub>	Supply voltage range	-0.5	6	V		
V <sub>I</sub>	Input voltage range	-0.5	V <sub>CC</sub> + 0.5	V		
V <sub>O</sub>	Output voltage range	-0.5	V <sub>CC</sub> + 0.5	V		
T <sub>A</sub>	Operating free-air temperature range	TL16C754C	0	70	°C	
		TL16C754CI	-40	85		
T <sub>J</sub>	Junction temperature	TL16C754C	High K	0	105	°C
			Low K	0	122	
		TL16C754CI	-40	105		
T <sub>stg</sub>	Storage temperature range	-65	150	°C		

- (1) Stresses beyond those listed under “absolute maximum ratings” may cause permanent damage to the device. These are stress ratings only and functional operation of the device at these or any other conditions beyond those indicated under “recommended operating conditions” is not implied. Exposure to absolute-maximum-rated conditions for extended periods may affect device reliability.

**Table 8. Typical Package Thermal Characteristics**

PARAMETER		TEST CONDITION <sup>(1)</sup>	TYP	UNIT	
θ <sub>JA</sub>	Junction-to-free-air thermal resistance	Low K JEDEC test board, 1s (single signal layer), no air flow	73.1	°C/W	
		High K JEDEC test board, 2s2p (double signal layer, double buried power plane)	No air flow		50
			400 LFM		
		200 LFM			
θ <sub>JC</sub>	Junction-to-case thermal resistance	Cu cold plate measurement process	19	°C/W	
θ <sub>JB</sub>	Junction-to-board thermal resistance	EIA/JESD 51-8	28	°C/W	
Ψ <sub>JT</sub>	Junction-to-top of package	EIA/JESD 51-2	0.95	°C/W	
Ψ <sub>JB</sub>	Junction-to-board	EIA/JESD 51-6	25.8	°C/W	

- (1) For more details, please refer to TI application note on IC Package Thermal Metrics ([SPRA953](#)).

**Table 9. Typical Package Weight**

PACKAGE	WEIGHT IN GRAMS
64-pin TQFP PM	0.25

### Recommended Operating Conditions, V<sub>CC</sub> = 1.8 V ±10%

over operating free-air temperature range (unless otherwise noted)

PARAMETER		MIN	NOM	MAX	UNIT
V <sub>CC</sub>	Supply voltage	1.62	1.8	1.98	V
V <sub>I</sub>	Input voltage	0		V <sub>CC</sub>	V
V <sub>IH</sub>	High-level input voltage	1.4		1.98	V
V <sub>IL</sub>	Low-level input voltage	-0.3		0.4	V
V <sub>O</sub>	Output voltage	0		V <sub>CC</sub>	V
I <sub>OH</sub>	High-level output current			0.5	mA
I <sub>OL</sub>	Low-level output current			1	mA
	Oscillator/clock speed			16	MHz

**Recommended Operating Conditions,  $V_{CC} = 2.5\text{ V} \pm 10\%$** 

over operating free-air temperature range (unless otherwise noted)

PARAMETER		MIN	NOM	MAX	UNIT
$V_{CC}$	Supply voltage	2.25	2.5	2.75	V
$V_I$	Input voltage	0		$V_{CC}$	V
$V_{IH}$	High-level input voltage	1.8		2.75	V
$V_{IL}$	Low-level input voltage	-0.3		0.6	V
$V_O$	Output voltage	0		$V_{CC}$	V
$I_{OH}$	High-level output current	All outputs		1	mA
$I_{OL}$	Low-level output current	All outputs		2	mA
	Oscillator/clock speed			24	MHz

**Recommended Operating Conditions,  $V_{CC} = 3.3\text{ V} \pm 10\%$** 

over operating free-air temperature range (unless otherwise noted)

PARAMETER		MIN	NOM	MAX	UNIT
$V_{CC}$	Supply voltage	3	3.3	3.6	V
$V_I$	Input voltage	0		$V_{CC}$	V
$V_{IH}$	High-level input voltage	$0.7 \times V_{CC}$			V
$V_{IL}$	Low-level input voltage			$0.3 \times V_{CC}$	V
$V_O$	Output voltage	0		$V_{CC}$	V
$I_{OH}$	High-level output current	All outputs		1.8	mA
$I_{OL}$	Low-level output current	All outputs		3.2	mA
	Oscillator/clock speed			32	MHz

**Recommended Operating Conditions,  $V_{CC} = 5\text{ V} \pm 10\%$** 

over operating free-air temperature range (unless otherwise noted)

PARAMETER		MIN	NOM	MAX	UNIT
$V_{CC}$	Supply voltage			5.5	V
$V_I$	Input voltage			$V_{CC}$	V
$V_{IH}$	High-level input voltage	Except XIN	0		V
		XIN	$0.7 \times V_{CC}$		
$V_{IL}$	Low-level input voltage	Except XIN	0.8		V
		XIN	$0.3 \times V_{CC}$		
$V_O$	Output voltage	0		$V_{CC}$	V
$I_{OH}$	High-level output current	All outputs		4	mA
$I_{OL}$	Low-level output current	All outputs		4	mA
	Oscillator/clock speed			48	MHz

**Electrical Characteristics,  $V_{CC} = 1.8\text{ V}$** 

over operating free-air temperature range (unless otherwise noted)

PARAMETER		TEST CONDITIONS	MIN	TYP	MAX	UNIT
$V_{OH}$	High-level output voltage	$I_{OH} = -0.5\text{ mA}$	1.3			V
$V_{OL}$	Low-level output voltage	$I_{OL} = 1\text{ mA}$			0.5	V
$I_I$	Input current	$V_{CC} = 1.98\text{ V}$ , $V_I = 0\text{ to }1.98\text{ V}$ ,			10	$\mu\text{A}$
$I_{OZ}$	High-impedance state output current	$V_{CC} = 1.98\text{ V}$ , $V_O = 0\text{ to }1.98\text{ V}$ , Chip selected in write mode or chip deselect			$\pm 20$	$\mu\text{A}$
$I_{CC}$	Supply current	$V_{CC} = 1.98\text{ V}$ , $T_A = 0^\circ\text{C}$ , SIN, $\overline{\text{DSR}}$ , $\overline{\text{DCD}}$ , $\overline{\text{CTS}}$ , and $\overline{\text{RI}}$ at 2 V, All other inputs at 0.4 V, No load on outputs,			4	mA
$C_{I(\text{CLK})}$	Clock input capacitance			5	7	pF
$C_{O(\text{CLK})}$	Clock output capacitance	$V_{CC} = 0$ , $f = 1\text{ MHz}$ ,		5	7	pF
$C_I$	Input capacitance	All other terminals grounded		6	10	pF
$C_O$	Output capacitance			10	15	pF

**Electrical Characteristics,  $V_{CC} = 2.5\text{ V}$** 

over operating free-air temperature range (unless otherwise noted)

PARAMETER		TEST CONDITIONS	MIN	TYP	MAX	UNIT
$V_{OH}$	High-level output voltage	$I_{OH} = -1\text{ mA}$	1.8			V
$V_{OL}$	Low-level output voltage	$I_{OL} = 2\text{ mA}$			0.5	V
$I_I$	Input current	$V_{CC} = 2.75\text{ V}$ , $V_I = 0\text{ to }2.75\text{ V}$ ,			10	$\mu\text{A}$
$I_{OZ}$	High-impedance state output current	$V_{CC} = 2.75\text{ V}$ , $V_O = 0\text{ to }2.75\text{ V}$ , Chip selected in write mode or chip deselect			$\pm 20$	$\mu\text{A}$
$I_{CC}$	Supply current	$V_{CC} = 2.75\text{ V}$ , $T_A = 0^\circ\text{C}$ , SIN, $\overline{\text{DSR}}$ , $\overline{\text{DCD}}$ , $\overline{\text{CTS}}$ , and $\overline{\text{RI}}$ at 2 V, All other inputs at 0.6 V, No load on outputs,			6	mA
$C_{I(\text{CLK})}$	Clock input capacitance			5	7	pF
$C_{O(\text{CLK})}$	Clock output capacitance	$V_{CC} = 0$ , $f = 1\text{ MHz}$ ,		5	7	pF
$C_I$	Input capacitance	All other terminals grounded		6	10	pF
$C_O$	Output capacitance			10	15	pF

### Electrical Characteristics, $V_{CC} = 3.3\text{ V}$

over operating free-air temperature range (unless otherwise noted)

PARAMETER		TEST CONDITIONS	MIN	TYP	MAX	UNIT
$V_{OH}$	High-level output voltage	$I_{OH} = -1.8\text{ mA}$	2.4			V
$V_{OL}$	Low-level output voltage	$I_{OL} = 3.2\text{ mA}$			0.5	V
$I_I$	Input current	$V_{CC} = 3.6\text{ V}$ , $V_I = 0\text{ to }3.6\text{ V}$ , $V_{SS} = 0$ , All other terminals floating			10	$\mu\text{A}$
$I_{OZ}$	High-impedance state output current	$V_{CC} = 3.6\text{ V}$ , $V_O = 0\text{ to }3.6\text{ V}$ , Chip selected in write mode or chip deselect			$\pm 20$	$\mu\text{A}$
$I_{CC}$	Supply current	$V_{CC} = 3.6\text{ V}$ , $T_A = 0^\circ\text{C}$ , SIN, $\overline{\text{DSR}}$ , $\overline{\text{DCD}}$ , $\overline{\text{CTS}}$ , and $\overline{\text{RI}}$ at 2 V, All other inputs at 0.8 V, No load on outputs,			12	mA
$C_{I(\text{CLK})}$	Clock input capacitance			5	7	pF
$C_{O(\text{CLK})}$	Clock output capacitance	$V_{CC} = 0$ , $f = 1\text{ MHz}$ ,		5	7	pF
$C_I$	Input capacitance	All other terminals grounded		6	10	pF
$C_O$	Output capacitance			10	15	pF

### Electrical Characteristics, $V_{CC} = 5\text{ V}$

over operating free-air temperature range (unless otherwise noted)

PARAMETER		TEST CONDITIONS	MIN	TYP	MAX	UNIT
$V_{OH}$	High-level output voltage	$I_{OH} = -4\text{ mA}$	4			V
$V_{OL}$	Low-level output voltage	$I_{OL} = 4\text{ mA}$			0.4	V
$I_I$	Input current	$V_{CC} = 5.5\text{ V}$ , $V_I = 0\text{ to }5.5\text{ V}$ , $V_{SS} = 0$ , All other terminals floating			10	$\mu\text{A}$
$I_{OZ}$	High-impedance state output current	$V_{CC} = 5.5\text{ V}$ , $V_O = 0\text{ to }5.5\text{ V}$ , Chip selected in write mode or chip deselect			$\pm 20$	$\mu\text{A}$
$I_{CC}$	Supply current	$V_{CC} = 5.5\text{ V}$ , $T_A = 0^\circ\text{C}$ , SIN, $\overline{\text{DSR}}$ , $\overline{\text{DCD}}$ , $\overline{\text{CTS}}$ , and $\overline{\text{RI}}$ at 2 V, All other inputs at 0.8 V, No load on outputs,			28	mA
$C_{I(\text{CLK})}$	Clock input capacitance			5	7	pF
$C_{O(\text{CLK})}$	Clock output capacitance	$V_{CC} = 0$ , $f = 1\text{ MHz}$ ,		5	7	pF
$C_I$	Input capacitance	All other terminals grounded		6	10	pF
$C_O$	Output capacitance			10	15	pF

### Typical Characteristics

All channels active

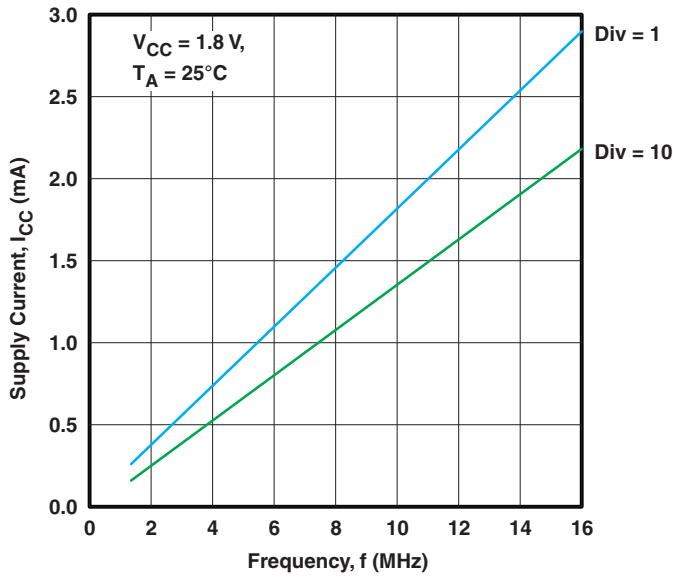

Figure 9. Supply Current vs Frequency (V<sub>CC</sub> = 1.8 V)

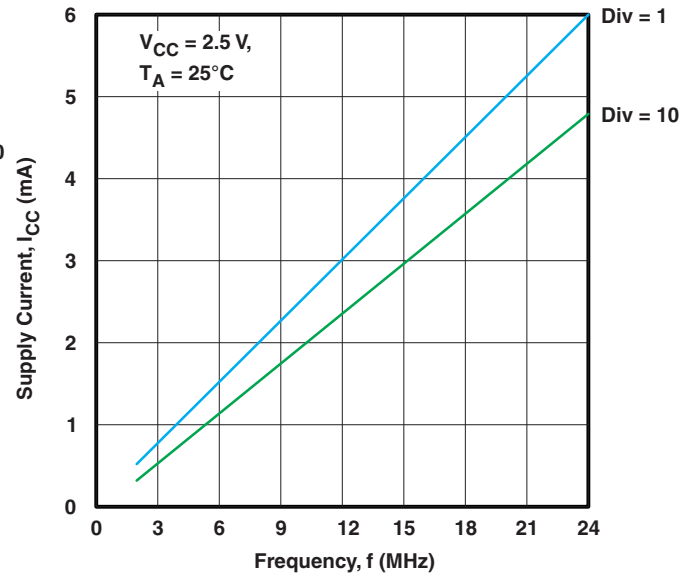

Figure 10. Supply Current vs Frequency (V<sub>CC</sub> = 2.5 V)

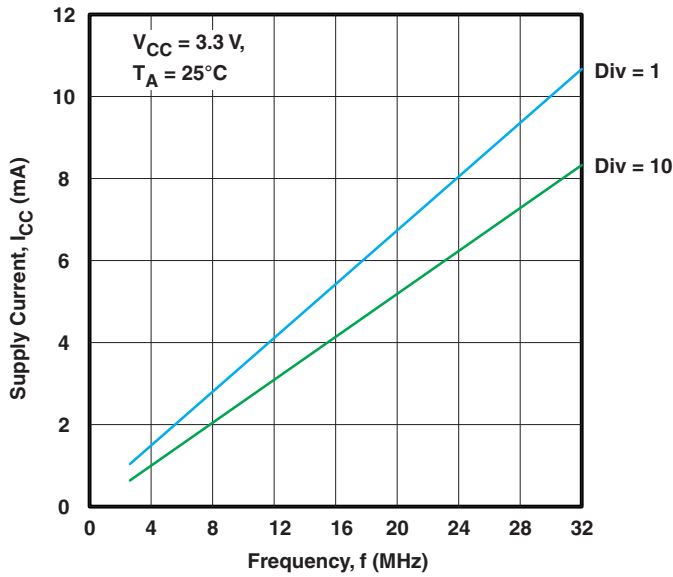

Figure 11. Supply Current vs Frequency (V<sub>CC</sub> = 3.3 V)

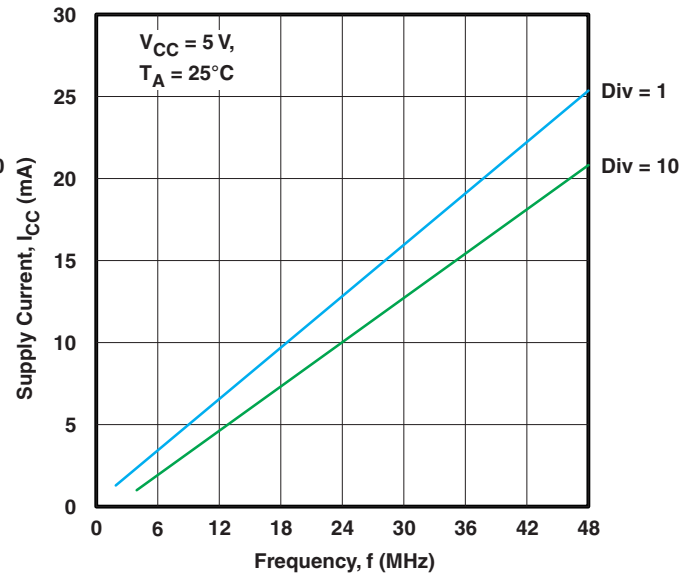

Figure 12. Supply Current vs Frequency (V<sub>CC</sub> = 5 V)

## Timing Requirements

$T_A = 0^\circ\text{C}$  to  $70^\circ\text{C}$ ,  $V_{CC} = 1.8\text{ V}$  to  $5\text{ V} \pm 10\%$  (unless otherwise noted)

PARAMETER	TEST CONDITIONS	LIMITS								UNIT
		1.8 V		2.5 V		3.3 V		5 V		
		MIN	MAX	MIN	MAX	MIN	MAX	MIN	MAX	
$t_{RES\_ET}^{\text{RES}}$ Reset pulse width		200		200		200		200		ns
$C_P$ CP Clock period		63		42		32		20		ns
$t_{3w}$ Oscillator/Clock speed			16		24		32		48	MHz
$t_{6s}$ Address setup time		20		15		10		5		ns
$t_{6h}$ Address hold time	See <a href="#">Figure 13</a> and <a href="#">Figure 14</a>	15		10		7		5		ns
$t_{7w}$ IOR strobe width	See <a href="#">Figure 13</a> and <a href="#">Figure 14</a>	85		70		50		40		ns
$t_{9d}$ Read cycle delay	See <a href="#">Figure 14</a>	85		70		60		50		ns
$t_{12d}$ Delay from IOR to data	See <a href="#">Figure 14</a>		65		50		35		25	ns
$t_{12h}$ Data disable time			35		25		20		15	ns
$t_{13w}$ IOW strobe width	See <a href="#">Figure 13</a>	85		70		50		40		ns
$t_{15d}$ Write cycle delay	See <a href="#">Figure 13</a>	85		70		60		50		ns
$t_{16s}$ Data setup time	See <a href="#">Figure 13</a>	40		30		20		15		ns
$t_{16h}$ Data hold time	See <a href="#">Figure 13</a>	35		25		15		10		ns
$t_{17d}$ Delay from IOW to output	50 pF load, See <a href="#">Figure 15</a>		60		40		30		20	ns
$t_{18d}$ Delay to set interrupt from MODEM input	50 pF load, See <a href="#">Figure 15</a>		70		55		45		35	ns
$t_{19d}$ Delay to reset interrupt from IOR	50 pF load		80		55		40		30	ns
$t_{20d}$ Delay from stop to set interrupt	See <a href="#">Figure 16</a>		1		1		1		1	Baudrate
$t_{21d}$ Delay from IOR to reset interrupt	50 pF load, See <a href="#">Figure 16</a>		55		45		35		25	ns
$t_{22d}$ Delay from stop to interrupt	See <a href="#">Figure 19</a>		1		1		1		1	Baudrate
$t_{23d}$ Delay from initial IOW reset to transmit star	See <a href="#">Figure 19</a>	8	24	8	24	8	24	8	24	Baudrate
$t_{24d}$ Delay from IOW to reset interrupt	See <a href="#">Figure 19</a>		75		45		35		25	ns
$t_{25d}$ Delay from stop to set RXRDY	See <a href="#">Figure 17</a> and <a href="#">Figure 18</a>		1		1		1		1	Baudrate
$t_{26d}$ Delay from IOR to reset RXRDY	See <a href="#">Figure 17</a> and <a href="#">Figure 18</a>		1		1		1		1	$\mu\text{s}$
$t_{27d}$ Delay from IOW to set TXRDY	See <a href="#">Figure 20</a> and <a href="#">Figure 21</a>		70		60		50		40	ns
$t_{28d}$ Delay from start to reset TXRDY	See <a href="#">Figure 20</a> and <a href="#">Figure 21</a>		16		16		16		16	Baudrate

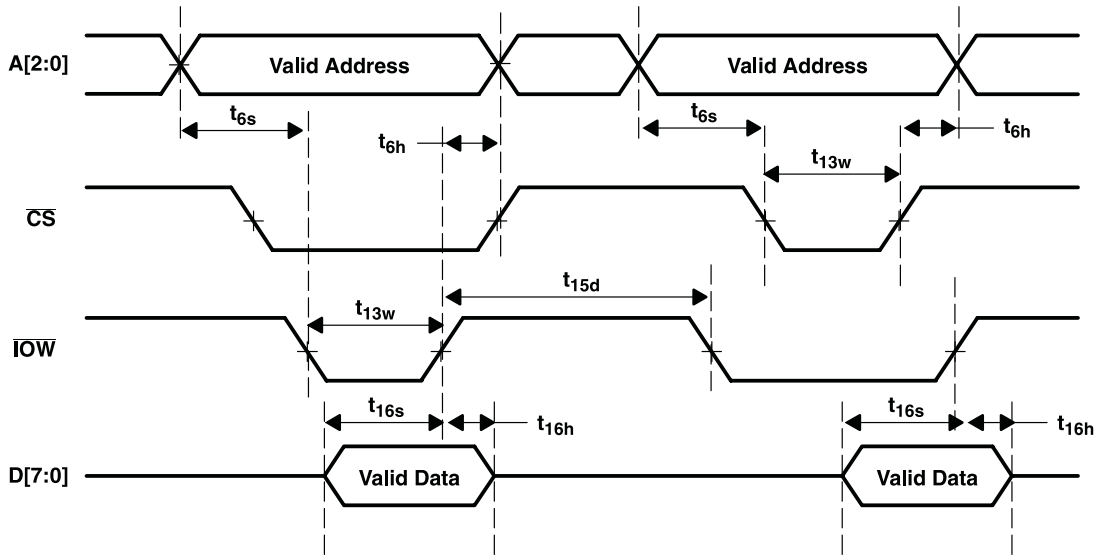

Figure 13. General Write Timing

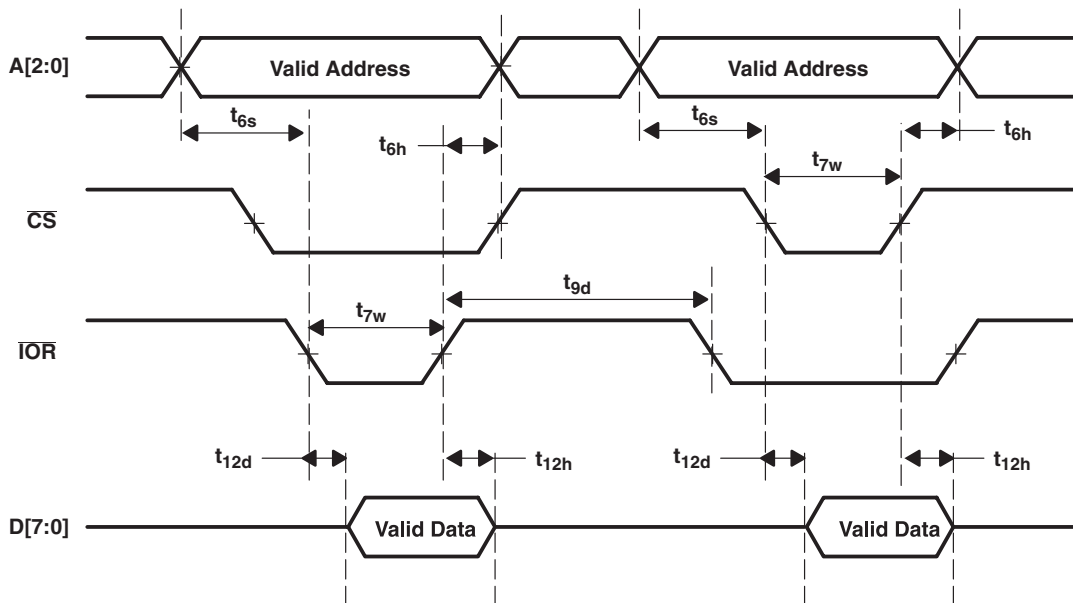

Figure 14. General Read Timing

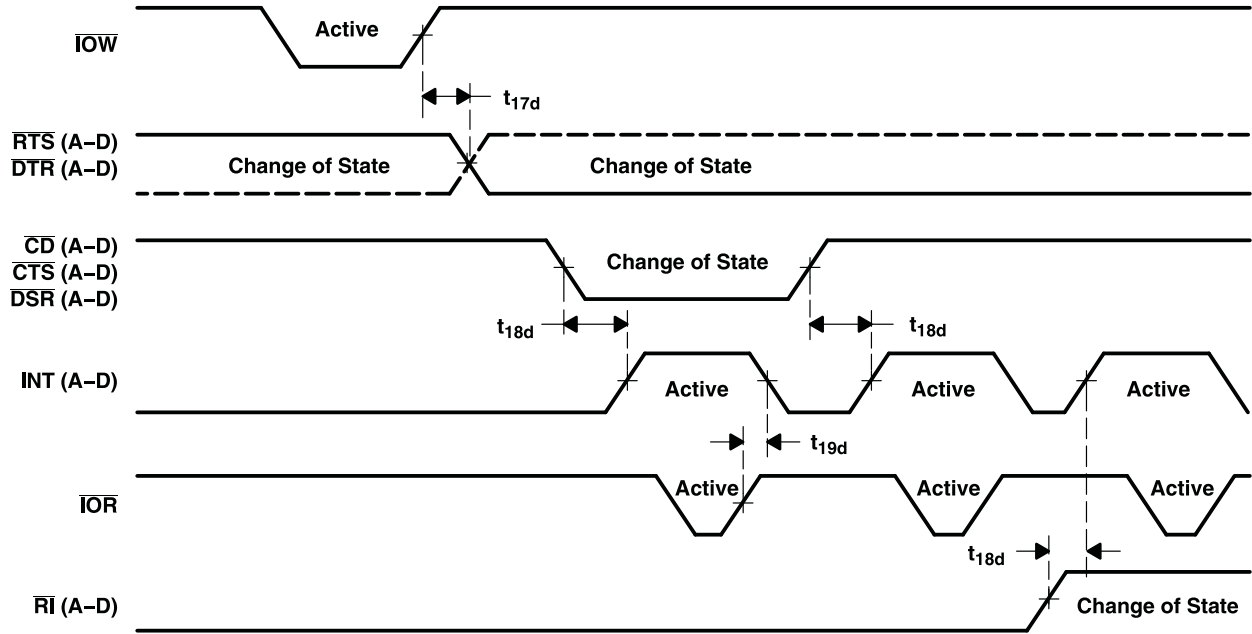

Figure 15. Modem or Output Timing

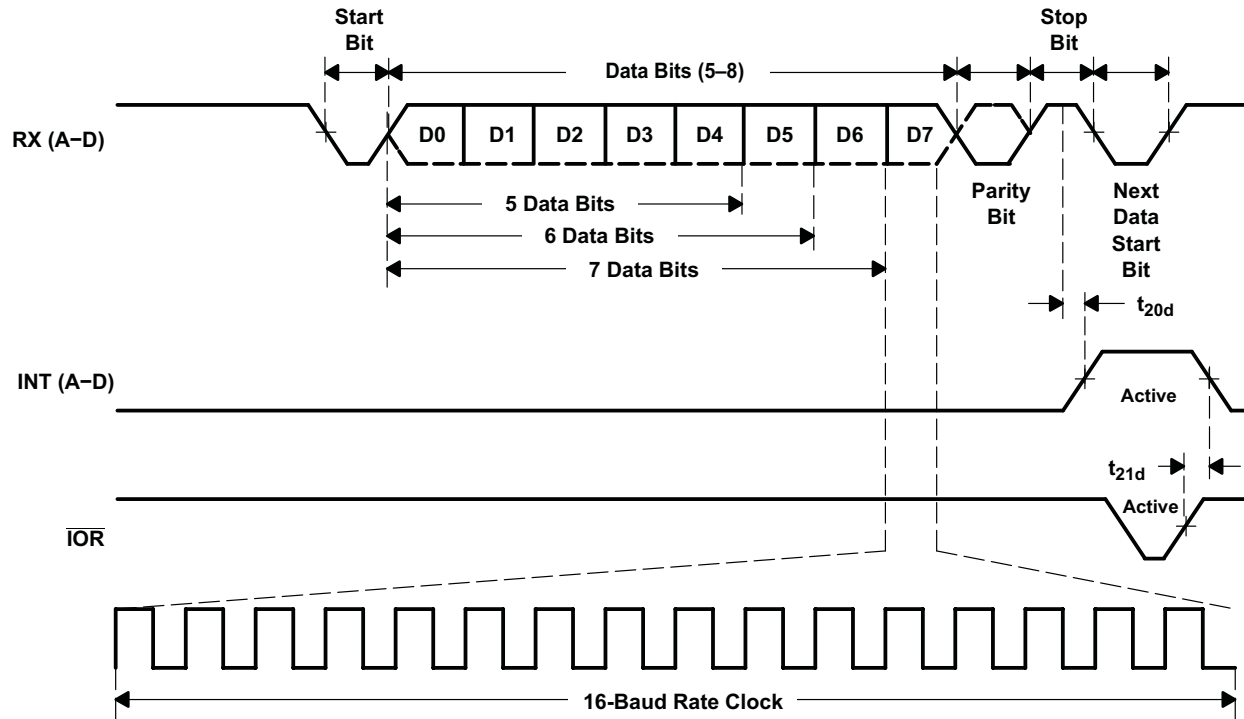

Figure 16. Receive Timing

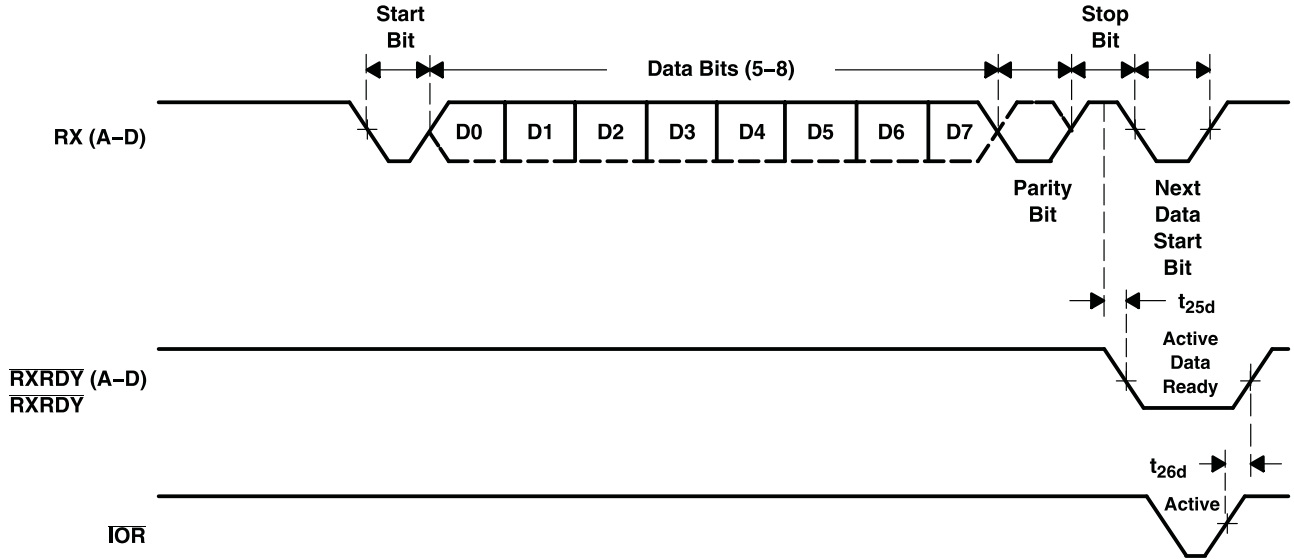

Figure 17. Receive Ready Timing in None FIFO Mode

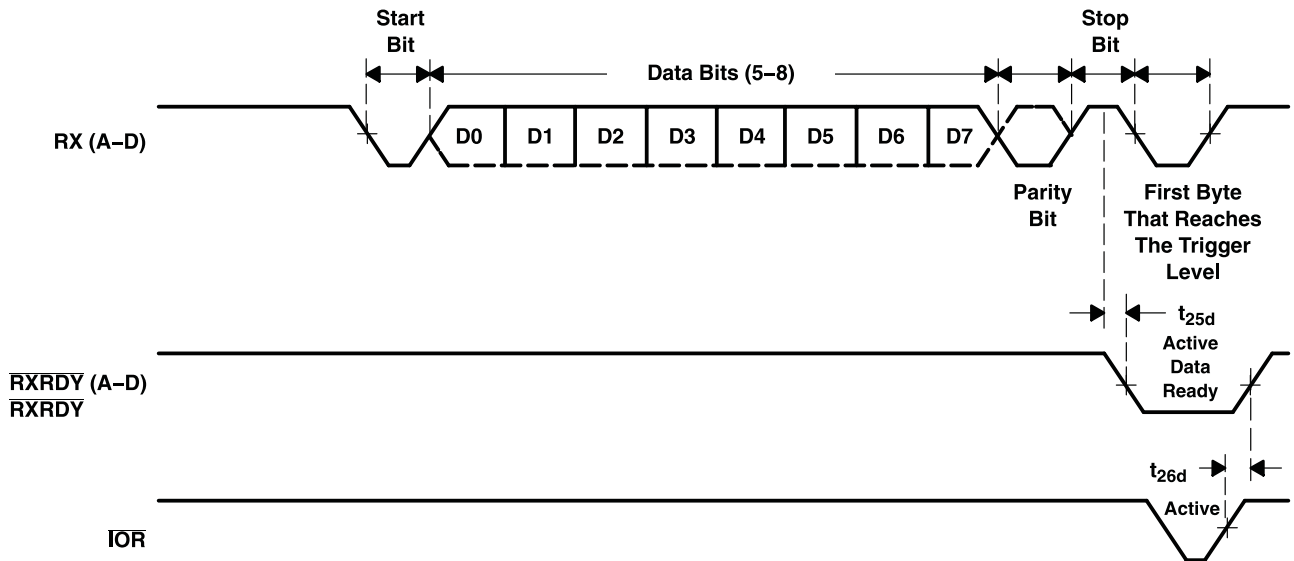

Figure 18. Receive Timing in FIFO Mode



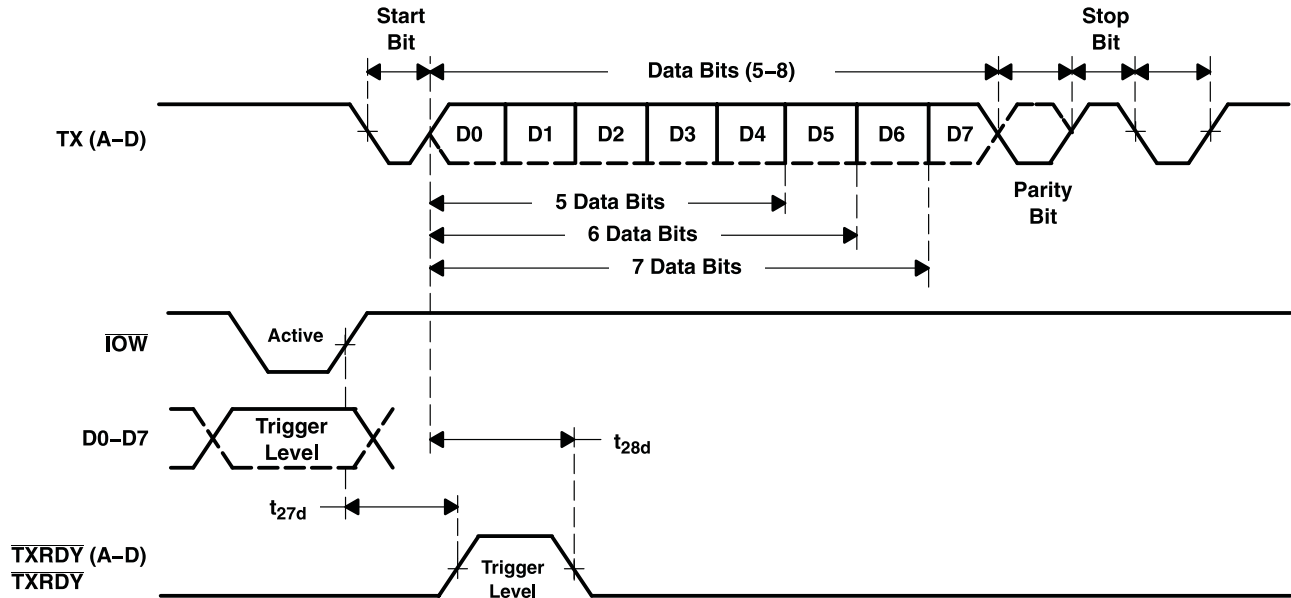

Figure 21. Transmit Timing in FIFO Mode

### Principles of Operation

#### Register Map

Each register is selected using address lines A[0], A[1], A[2], and in some cases, bits from other registers. The programming combinations for register selection are shown in Figure 22.

ADDRESS [A2:A0]	READ MODE			WRITE MODE			
000	RHR Recieve Holding	DLL Divisor Latch LSB		THR Transmit Holding	DLL Divisor Latch LSB		
001	IER Interrupt Enable	DLH Divisor Latch MSB		IER Interrupt Enable	DLH Divisor Latch MSB		
010	IIR Interrupt Identification	AFR Alternate Function	EFR Enhanced feature	FCR FIFO Control	AFR Alternate Function	EFR Enhanced feature	
011	LCR Line Control			LCR Line Control			
100	MCR Modem Control	Xon1 Xon 1 word		MCR Modem Control	Xon1 Xon 1 word		
101	LSR Line Status	Xon2 Xon 2 word			Xon2 Xon 2 word		
110	MSR Modem Status	Xoff1 Xoff 1 word	TCR Transmission Control		Xoff1 Xoff 1 word	TCR Transmission Control	
111	SPR Scratch Register	Xoff2 Xoff 2 word	TLR Trigger Level	FIFO RDY FIFO Ready Register	SPR Scratch Register	Xoff2 Xoff 2 word	TLR Trigger Level

- Accessible only when LCR[7] = 1
- Accessible only when LCR[7:5] = 100
- Accessible only when LCR = 1011 1111 (0xBF)
- Accessible only when EFR[4] = 1 and MCR[6]=1
- Accessible when any CS A–D = 0, MCR[2] = 1 and loopback MCR [4] = 0 is disabled.

NOTE: MCR[7:5], FCR[5:4] and IER[7:4] can only be modified when EFR[4] is set.

Figure 22. Register Map – Read and Write Properties

Table 10 lists and describes the '754C internal registers.

**Table 10. '754C Internal Registers <sup>(1)</sup>**

ADDRESS	REGISTER	R/W <sup>(2)</sup>	ACCESS CONSIDERATION	BIT 7	BIT 6	BIT 5	BIT 4	BIT 3	BIT 2	BIT 1	BIT 0
0 0 0	RHR	R	LCR[7] = 0	bit 7 0	bit 6 0	bit 5 0	bit 4 0	bit 3 0	bit 2 0	bit 1 0	bit 0 0
	THR	W		bit 7 0	bit 6 0	bit 5 0	bit 4 0	bit 3 0	bit 2 0	bit 1 0	bit 0 0
	DLL <sup>(3)</sup>	RW	LCR[7] = 1	bit 7	bit 6	bit 5	bit 4	bit 3	bit 2	bit 1	bit 0
0 0 1	IER	RW	LCR[7] = 0	CTS# Interrupt enable <sup>(4)</sup> 0	RTS# Interrupt enable <sup>(4)</sup> 0	Xoff Interrupt enable <sup>(4)</sup> 0	Sleep mode <sup>(4)</sup> 0	Modem status interrupt 0	Rx line status interrupt 0	THR empty interrupt 0	Rx data available interrupt 0
	DLH <sup>(3)</sup>	RW	LCR[7] = 1	bit 7	bit 6	bit 5	bit 4	bit 3	bit 2	bit 1	bit 0
0 1 0	IIR	R	LCR[7] = 0	FCR(0) 0	FCR(0) 0	CTS# / RTS# 0	Xoff 0	Interrupt priority bit 2 0	Interrupt priority bit 1 0	Interrupt priority bit 0 0	Interrupt status 1
	FCR	W		Rx trigger level 0	Rx trigger level 0	Tx trigger level <sup>(2)</sup> 0	Tx trigger level <sup>(4)</sup> 0	DMA mode select 0	Resets Tx FIFO 0	Resets Rx FIFO 0	Enable FIFOs 0
	AFR <sup>(5)</sup>	RW	LCR[7:5] = 100	DLY2 0	DLY1 0	DLY0 0	RCVEN 1	485LG 0	485RN 0	IREN 0	CONC 0
	EFR <sup>(6)</sup>	RW	LCR[7:0] = 10111111	Auto CTS# 0	Auto RTS# 0	Special character detect 0	Enable enhanced functions 0	S/W flow control bit 3 0	S/W flow control bit 2 0	S/W flow control bit 1 0	S/W flow control bit 0 0
0 1 1	LCR	RW	None	DLAB & EFR enable 0	Break control bit 0	Sets parity 0	Parity type select 1	Parity enable 1	No. of stop bits 1	Word length 0	Word length 1
1 0 0	MCR	RW	LCR[7:0] ≠ 10111111	1x / 4x clock <sup>(4)</sup> 0	TCR & TLR enable <sup>(4)</sup> 0	Xon any <sup>(4)</sup> 0	Enable loopback 0	IRQ enable 0	FIFORdy enable 0	RTS# 0	DTR# 0
	Xon1 <sup>(6)</sup>	RW	LCR[7:0] = 10111111	bit 7 1	bit 6 1	bit 5 1	bit 4 1	bit 3 1	bit 2 1	bit 1 1	bit 0 1
1 0 1	LSR	R	LCR[7:0] ≠ 10111111	Error in Rx FIFO 0	THR & TSR empty 1	THR empty 1	Break interrupt 0	Framing error 0	Parity error 0	Overrun error 0	Data in receiver 0
	Xon2 <sup>(6)</sup>	RW	LCR[7:0] = 10111111	bit 7 1	bit 6 1	bit 5 1	bit 4 0	bit 3 1	bit 2 1	bit 1 1	bit 0 1

(1) For more register access information, see [Figure 22](#).

(2) Read = R; Write = W

(3) This register is only accessible when LCR[7] = 1

(4) Bits represented by the blue shaded cells can only be modified if EFR[4] is enabled, that is, if enhanced functions are enabled.

(5) This register is only accessible LCR[7:5] = 100

(6) This register is only accessible when LCR = 1011 1111 (0xBF)

Table 10. '754C Internal Registers <sup>(1)</sup> (continued)

ADDRESS	REGISTER	R/W (2)	ACCESS CONSIDERATION	BIT 7	BIT 6	BIT 5	BIT 4	BIT 3	BIT 2	BIT 1	BIT 0
1 1 0	MSR	R	LCR[7:0] ≠ 10111111	CD# 1	RI# 1	DSR# 1	CTS# 0	ΔCD# 0	ΔRI# 0	ΔDSR# 0	ΔCTS# 0
	Xoff1 <sup>(6)</sup>	RW	LCR[7:0] = 10111111	bit 7 1	bit 6 1	bit 5 1	bit 4 1	bit 3 1	bit 2 1	bit 1 1	bit 0 1
	TCR <sup>(7)</sup>	RW	EFR[4] = 1 & MCR[6] = 1	bit 7 0	bit 6 0	bit 5 0	bit 4 0	bit 3 0	bit 2 0	bit 1 0	bit 0 0
1 1 1	SPR	RW	LCR[7:0] ≠ 10111111	bit 7 1	bit 6 1	bit 5 1	bit 4 1	bit 3 1	bit 2 1	bit 1 1	bit 0 1
	Xoff2 <sup>(6)</sup>	RW	LCR[7:0] = 10111111	bit 7 1	bit 6 1	bit 5 1	bit 4 1	bit 3 1	bit 2 1	bit 1 1	bit 0 1
	TLR <sup>(7)</sup>	RW	EFR[4] = 1 & MCR[6] = 1	bit 7 0	bit 6 0	bit 5 0	bit 4 0	bit 3 0	bit 2 0	bit 1 0	bit 0 0
	FIFORdy <sup>(8)</sup>	R	MCR[4] = 0 & MCR[2] = 1	RX FIFO D status 0	RX FIFO C status 0	RX FIFO B status 0	RX FIFO A status 0	TX FIFO D status 0	TX FIFO C status 0	TX FIFO B status 0	TX FIFO A status 0

(7) This register is only accessible when EFR[4] = 1 and MCR[6] = 1

(8) This register is accessible when any CS A–D = 0, MCR[2] = 1, and loopback MCR[4] = 0 is disabled

## Receiver Holding Register (RHR)

The receiver section consists of the receiver holding register (RHR) and the receiver shift register (RSR). The RHR is actually a 64-byte FIFO. The RSR receives serial data from RX terminal. The data is converted to parallel data and moved to the RHR. The receiver section is controlled by the line control register. If the FIFO is disabled, location 0 of the FIFO is used to store the characters. If overflow occurs, characters are lost. The RHR also stores the error status bits associated with each character.

## Transmit Holding Register (THR)

The transmitter section consists of the transmit holding register (THR) and the transmit shift register (TSR). The transmit holding register is actually a 64-byte FIFO. The THR receives data and shifts it into the TSR where it is converted to serial data and moved out on the TX terminal. If the FIFO is disabled, location 0 of the FIFO is used to store the byte. Characters are lost if overflow occurs.

## FIFO Control Register (FCR)

This is a write-only register which is used for enabling the FIFOs, clearing the FIFOs, setting transmitter and receiver trigger levels, and selecting the type of DMA signaling. [Table 11](#) shows FIFO control register bit settings.

**Table 11. FIFO Control Register (FCR) Bit Settings**

BIT NO.	BIT SETTINGS
0	0 = Disable the transmit and receive FIFOs 1 = Enable the transmit and receive FIFOs
1	0 = No change 1 = Clears the receive FIFO and resets its counter logic to 0. Returns to 0 after clearing FIFO.
2	0 = No change 1 = Clears the transmit FIFO and resets its counter logic to 0. Returns to 0 after clearing FIFO.
3	0 = DMA Mode 0 1 = DMA Mode 1
5:4 <sup>(1)</sup>	Sets the trigger level for the TX FIFO: 00 – 8 spaces 01 – 16 spaces 10 – 32 spaces 11 – 56 spaces
7:6	Sets the trigger level for the RX FIFO: 00 – 1 characters 01 – 4 characters 10 – 56 characters 11 – 60 characters

(1) FCR[5–4] can be modified and enabled only when EFR[4] is set. This is because the transmit trigger level is regarded as an enhanced function.

## Line Control Register (LCR)

This register controls the data communication format. The word length, number of stop bits, and parity type are selected by writing the appropriate bits to the LCR. [Table 12](#) shows line control register bit settings.

**Table 12. Line Control Register (LCR) Bit Settings**

BIT NO.	BIT SETTINGS
1:0	Specifies the word length to be transmitted or received. 00 – 5 bits 01 – 6 bits 10 – 7 bits 11 – 8 bits
2	Specifies the number of stop bits: 0 – 1 stop bits (Word length = 5, 6, 7, 8) 1 – 1.5 stop bits (Word length = 5) 1 – 2 stop bits (Word length = 6, 7, 8) 3
3	0 = No parity 1 = A parity bit is generated during transmission and the receiver checks for received parity.
4	0 = Odd parity is generated (if LCR[3] = 1) 1 = Even parity is generated (if LCR[3] = 1)
5	Selects the forced parity format (if LCR(3) = 1) If LCR[5] = 1 and LCR[4] = 0 the parity bit is forced to 1 in the transmitted and received data. If LCR[5] = 1 and LCR[4] = 1 the parity bit is forced to 0 in the transmitted and received data.
6	Break control bit. 0 = Normal operating condition 1 = Forces the transmitter output to go low to alert the communication terminal.
7	0 = Normal operating condition 1 = Divisor latch enable

### Line Status Register (LSR)

Table 13 shows line status register bit settings.

**Table 13. Line Status Register (LSR) Bit Settings**

BIT NO.	BIT SETTINGS
0	0 = No data in the receive FIFO 1 = At least one character in the RX FIFO
1	0 = No overrun error 1 = Overrun error has occurred
2	0 = No parity error in data being read from RX FIFO 1 = Parity error in data being read from RX FIFO
3	0 = No framing error in data being read from RX FIFO 1 = Framing error occurred in data being read from RX FIFO (that is, received data did not have a valid stop bit)
4	0 = No break condition 1 = A break condition occurred and associated byte is 00 (that is, RX was low for at least one character time frame)
5	0 = Transmit hold register is not empty 1 = Transmit hold register is empty. The processor can now load up to 64 bytes of data into the THR if the TX FIFO is enabled.
6	0 = Transmitter hold AND shift registers are not empty 1 = Transmitter hold AND shift registers are empty
7	0 = Normal operation 1 = At least one parity error, framing error or break indication are stored in the receiver FIFO. Bit 7 is cleared when no errors are present in the FIFO.

When the LSR is read, LSR[4:2] reflects the error bits [BI, FE, PE] of the character at the top of the RX FIFO (next character to be read). The LSR[4:2] registers do not physically exist, as the data read from the RX FIFO is output directly onto the output data-bus, DI[4:2], when the LSR is read. Therefore, errors in a character are identified by reading the LSR and then reading the RHR.

LSR[7] is set when there is an error anywhere in the RX FIFO and is cleared only when there are no more errors remaining in the FIFO.

**NOTE**

Reading the LSR does not cause an increment of the RX FIFO read pointer. The RX FIFO read pointer is incremented by reading the RHR.

**Modem Control Register (MCR)**

The MCR controls the interface with the modem, data set, or peripheral device that is emulating the modem. [Table 14](#) shows modem control register bit settings.

**Table 14. Modem Control Register (MCR) Bit Settings<sup>(1)</sup>**

BIT NO.	BIT SETTINGS
0	0 = Force $\overline{\text{DTR}}$ output to inactive (high) 1 = Force $\overline{\text{DTR}}$ output to active (low). In loopback controls MSR[5].
1	0 = Force $\overline{\text{RTS}}$ output to inactive (high) 1 = Force $\overline{\text{RTS}}$ output to active (low) In loopback controls MSR[4] If Auto-RTS is enabled the $\overline{\text{RTS}}$ output is controlled by hardware flow control
2	0 Disables the FIFORDy register 1 Enable the FIFORDy register In loopback controls MSR[6]
3	0 = Forces the IRQ(A–D) outputs to high-impedance state 1 = Forces the IRQ(A–D) outputs to the active state. In loopback controls MSR[7]
4	0 = Normal operating mode 1 = Enable local loopback mode (internal) In this mode, the MCR[3:0] signals are looped back into MSR[3:0] and the TX output is looped back to the RX input internally
5	0 = Disable Xon Any function 1 = Enable Xon Any function
6	0 = No action 1 = Enable access to the TCR and TLR registers
7	0 = Divide by one clock input 1 = Divide by four clock input This bit reflects the inverse of the CLKSEL pin value at the trailing edge of the RESET pulse

(1) MCR[7:5] can only be modified when EFR[4] is set, that is, EFR[4] is a write enable.

## Modem Status Register (MSR)

This 8-bit register provides information about the current state of the control lines from the modem, data set, or peripheral device to the processor. It also indicates when a control input from the modem changes state. [Table 15](#) shows modem status register bit settings.

**Table 15. Modem Status Register (MSR) Bit Settings<sup>(1)</sup>**

BIT NO.	BIT SETTINGS
0	Indicates that $\overline{\text{CTS}}$ input (or MCR[1] in loopback) has changed state. Cleared on a read.
1	Indicates that $\overline{\text{DSR}}$ input (or MCR[0] in loopback) has changed state. Cleared on a read.
2	Indicates that $\overline{\text{RI}}$ input (or MCR[2] in loopback) has changed state from low to high. Cleared on a read.
3	Indicates that $\overline{\text{CD}}$ input (or MCR[3] in loopback) has changed state. Cleared on a read.
4	This bit is equivalent to MCR[1] during local loop-back mode. It is the complement to the $\overline{\text{CTS}}$ input.
5	This bit is equivalent to MCR[0] during local loop-back mode. It is the complement to the $\overline{\text{DSR}}$ input.
6	This bit is equivalent to MCR[2] during local loop-back mode. It is the complement to the $\overline{\text{RI}}$ input.
7	This bit is equivalent to MCR[3] during local loop-back mode. It is the complement to the $\overline{\text{CD}}$ input.

(1) The primary inputs  $\overline{\text{RI}}$ ,  $\overline{\text{CD}}$ ,  $\overline{\text{CTS}}$ , and  $\overline{\text{DSR}}$  are all active low, but their registered equivalents in the MSR and MCR (in loopback) registers are active high.

## Interrupt Enable Register (IER)

The interrupt enable register (IER) enables each of the six types of interrupt, receiver error, RHR interrupt, THR interrupt, Xoff received, or  $\overline{\text{CTS/RTS}}$  change of state from low to high. The INT output signal is activated in response to interrupt generation. [Table 16](#) shows interrupt enable register bit settings.

**Table 16. Interrupt Enable Register (IER) Bit Settings<sup>(1)</sup>**

BIT NO.	BIT SETTINGS
0	0 = Disable the RHR interrupt 1 = Enable the RHR interrupt
1	0 = Disable the THR interrupt 1 = Enable the THR interrupt
2	0 = Disable the receiver line status interrupt 1 = Enable the receiver line status interrupt
3	0 = Disable the modem status register interrupt 1 = Enable the modem status register interrupt
4	0 = Disable sleep mode 1 = Enable sleep mode
5	0 = Disable the Xoff interrupt 1 = Enable the Xoff interrupt
6	0 = Disable the $\overline{\text{RTS}}$ interrupt 1 = Enable the $\overline{\text{RTS}}$ interrupt
7	0 = Disable the $\overline{\text{CTS}}$ interrupt 1 = Enable the $\overline{\text{CTS}}$ interrupt

(1) IER[7:4] can only be modified if EFR[4] is set, that is, EFR[4] is a write enable. Re-enabling IER[1] causes a new interrupt, if the THR is below the threshold.

## Interrupt Identification Register (IIR)

The IIR is a read-only 8-bit register, which provides the source of the interrupt in a prioritized manner. [Table 17](#) shows interrupt identification register bit settings.

**Table 17. Interrupt Identification Register (IIR) Bit Settings**

BIT NO.	BIT SETTINGS
0	0 = An interrupt is pending 1 = No interrupt is pending
3:1	3-Bit encoded interrupt. See <a href="#">Table 16</a>
4	1 = Xoff or special character has been detected
5	$\overline{\text{CTS}}/\overline{\text{RTS}}$ low to high change of state
7:6	Mirror the contents of FCR[0]

The interrupt priority list is shown in [Table 18](#).

**Table 18. Interrupt Priority List**

PRIORITY LEVEL	BIT 5	BIT 4	BIT 3	BIT 2	BIT 1	BIT 0	INTERRUPT SOURCE
1	0	0	0	1	1	0	Receiver line status error
2	0	0	1	1	0	0	Receiver timeout interrupt
2	0	0	0	1	0	0	RHR interrupt
3	0	0	0	0	1	0	THR interrupt
4	0	0	1	0	0	0	Modem interrupt
5	0	1	0	0	0	0	Received Xoff signal or special character
6	1	0	0	0	0	0	$\overline{\text{CTS}}$ , $\overline{\text{RTS}}$ change of state from active (low) to inactive (high)

## Enhanced Feature Register (EFR)

This 8-bit register enables or disables the enhanced features of the UART. [Table 19](#) shows the enhanced feature register bit settings.

**Table 19. Enhanced Feature Register (EFR) Bit Settings**

BIT NO.	BIT SETTINGS
3:0	Combinations of software flow control can be selected by programming bit 3 to bit 0. See <a href="#">Table 2</a>
4	Enhanced functions enable bit. 0 = Disables enhanced functions and writing to IER[7:4], FCR[5:4], MCR[7:5] 1 = Enables the enhanced function IER[7:4], FCR[5:4], and MCR[7:5] can be modified, that is, this bit is therefore a write enable
5	0 = Normal operation 1 = Special character detect. Received data is compared with Xoff-2 data. If a match occurs, the received data is transferred to FIFO and IIR[4] is set to 1 to indicate a special character has been detected.
6	$\overline{\text{RTS}}$ flow control enable bit 0 = Normal operation 1 = $\overline{\text{RTS}}$ flow control is enabled, that is, $\overline{\text{RTS}}$ pin goes high when the receiver FIFO HALT trigger level TCR[3:0] is reached, and goes low when the receiver FIFO RESTORE transmission trigger level TCR[7:4] is reached.
7	$\overline{\text{CTS}}$ flow control enable bit 0 = Normal operation 1 = $\overline{\text{CTS}}$ flow control is enabled, that is, transmission is halted when a high signal is detected on the $\overline{\text{CTS}}$ pin

## Divisor Latches (DLL, DLH)

Two 8-bit registers store the 16-bit divisor for generation of the baud clock in the baud rate generator. DLH, stores the most significant part of the divisor. DLL stores the least significant part of the division.

DLL and DLH can only be written to before sleep mode is enabled (that is, before IER[4] is set).

## Transmission Control Register (TCR)

This 8-bit register is used to store the receive FIFO threshold levels to start or stop transmission during hardware or software flow control. [Table 20](#) shows transmission control register bit settings.

**Table 20. Transmission Control Register (TCR) Bit Settings**

BIT NO.	BIT SETTINGS
3:0	RCV FIFO trigger level to HALT transmission (0 to 60)
7:4	RCV FIFO trigger level to RESTORE transmission (0 to 60)

TCR trigger levels are available from 0 to 60 bytes with a granularity of four.

TCR can be written to only when EFR[4] = 1 and MCR[6] = 1. The programmer must program the TCR such that TCR[3:0] > TCR[7:4]. There is no built-in hardware check to make sure this condition is met. Also, the TCR must be programmed with this condition before Auto-RTS or software flow control is enabled to avoid spurious operation of the device.

## Trigger Level Register (TLR)

This 8-bit register is used to store the transmit and received FIFO trigger levels used for DMA and interrupt generation. Trigger levels from 4 to 60 can be programmed with a granularity of 4. [Table 21](#) shows trigger level register bit settings.

**Table 21. Trigger Level Register (TLR) Bit Settings**

BIT NO.	BIT SETTINGS
3:0	Transmit FIFO trigger levels (4 to 60), number of spaces available
7:4	RCV FIFO trigger levels (4 to 60), number of characters available

TLR can be written to only when EFR[4] = 1 and MCR[6] = 1. If TLR[3:0] or TLR[7:4] are 0, then the selectable trigger levels via the FIFO control register (FCR) are used for the transmit and receive FIFO trigger levels. Trigger levels from 4 to 60 bytes are available with a granularity of 4. The TLR should be programmed for  $N / 4$ , where N is the desired trigger level.

## FIFO Ready Register

The FIFO ready register provides realtime status of the transmit and receive FIFOs. [Table 22](#) shows the FIFO ready register bit settings.

**Table 22. FIFO Ready Register**

BIT NO.	BIT SETTINGS
3:0	0 = There are less than a TX trigger level number of spaces available in the TX FIFO. 1 = There are at least a TX trigger level number of spaces available in the TX FIFO
7:4	0 = There are less than a RX trigger level number of characters in the RX FIFO. 1 = The RX FIFO has more than a RX trigger level number of characters available for reading OR a timeout condition has occurred.

The FIFORdy register is a read only register and can be accessed when any of the four UARTs are selected CS A–D = 0, MCR[2] (FIFORdy Enable) is a 1 and loopback is disabled. Its address space is 111.

## Alternate Function Register (AFR)

The alternate function register (AFR) is used to enable some extra functionality beyond the capabilities of the original TL16C754. The first of these is a concurrent write mode, which can be useful in more expediently setting up all four UART channels. The second addition is the IrDA mode, which supports Standard IrDA (SIR) mode with baud rates from 2400 to 115.2 bps. The third addition is support for RS-485 bus drivers or transceivers by providing an output pin ( $\overline{\text{DTRx}}$ ) per channel, which is timed to keep the RS-485 driver enabled as long as transmit data is pending.

The AFR is located at  $\text{A}[2:0] = 010$  when  $\text{LCR}[7:5] = 100$ .

**Table 23. Alternate Function Register (AFR) Bit Settings**

BIT NO.	BIT SETTINGS
0	CONC enables the concurrent write of all four (754) or two (752) channels simultaneously, which helps speed up initialization. Ensure that any indirect addressing modes have been enabled before using.
1	IREN enables the IrDA SIR mode. This mode is only specified to 115.2 bps and use of this mode at higher speeds is not recommended.
2	485EN enables the half duplex RS-485 mode and causes the $\overline{\text{DTRx}}$ output to be set high whenever there is any data in the THR or TSR and to be held high until the delay set by $\text{DLY3:0}$ has expired, at which time it is set low. The $\overline{\text{DTRx}}$ output is intended to drive the enabled input of an RS-485 driver. When this bit is set, the transmitter interrupts are held off until the TSR is empty, unless 485LG is set.
3	485LG is set when the 485EN is set. This bit indicates that a relatively large data block is being set, requiring more than a single load of the xmt fifo. In this case, the transmitter interrupts occur as in the standard RS-232 mode, either when the xmt fifo contents drop below the xmt threshold or when the xmt fifo is empty.
4	RCVEN is valid only when 485EN or IREN is set, and allows the serial receiver to listen in or snoop on the RS485 traffic or IrDA traffic. RS485 mode is generally considered half duplex, and usually a node is either driving or receiving, but there can be cases when it is advantageous to verify what you are sending. This can be used to detect collisions or as part of an arbitration mechanism on the bus. When both RCVEN and 485EN are set, the receiver stores any data presented on RX, if any. Note that implies that the external RS485 receiver is enabled. Whenever 485EN is cleared, the serial receiver is enabled for normal full duplex RS232 traffic. If RCVEN is cleared while 485EN is set, the receiver is disabled while that channel is transmitting. Standard IrDA (SIR) is also considered half duplex. Often the light energy from the transmitting LED is coupled back into the receiving PIN diode, which creates an input data stream that is not of interest to the host. Disabling the receiver (clearing RCVEN) prevents this reception, and eliminates the task of unloading the data. On the other hand, for diagnostic or other purposes, it may be useful to observe this data stream. For example, a mirror could be used to intentionally couple the output LED to the input PIN. For these cases, RCVEN could be set to enable the receiver. NOTE: When RCVEN is cleared (set to 0), the character timeout interrupt is not available, even in RSA-232 mode. This can be useful when checking code for valid threshold interrupts, as the timeout interrupt will not override the threshold interrupt.
7:5	$\text{DLY3-DLY0}$ sets a delay after the last stop bit of the last data byte being set before the $\overline{\text{DTRx}}$ is set low, to allow for long cable runs. The delay is in number of bit times and is enabled by 485EN. The delay starts only when both the xmt serial shift register (TSR) is empty and the xmt fifo (THR) is empty, and if started, will be cleared by any data being written to the THR.

**Table 24. LOOP and RCVEN Functionality**

LOOP MODE	RCVEN	AFR	MODE	DESCRIPTION
LOOP mode off, MCR4 = 0, RX, TX active	RCVEN = 1	AFR = 10	RS-232	Receive threshold, timeout, and error detection interrupts available Data stored in receive FIFO
		AFR = 14	RS-485	Receive threshold, timeout, and error detection interrupts available Data stored in receive FIFO
		AFR = 12	IrDA	Receive threshold, timeout, and error detection interrupts available Data stored in receive FIFO
	RCVEN = 0	AFR = 00	RS-232	Receive threshold and error detection interrupts available Data stored in receive FIFO
		AFR = 04	RS-485	No data stored in receive FIFO, hence no interrupts available
		AFR = 02	IrDA	No data stored in receive FIFO, hence no interrupts available
LOOP mode on, MCR4 = 1, RX, TX inactive	RCVEN = 1	AFR = 10	RS-232	Receive threshold, timeout, and error detection interrupts available Data stored in receive FIFO
		AFR = 14	RS-485	Receive threshold, timeout, and error detection interrupts available Data stored in receive FIFO
		AFR = 12	IrDA	Receive threshold, timeout, and error detection interrupts available Data stored in receive FIFO
	RCVEN = 0	AFR = 00	RS-232	Receive threshold and error detection interrupts available Data stored in receive FIFO
		AFR = 04	RS-485	Receive threshold and error detection interrupts available Data stored in receive FIFO
		AFR = 02	IrDA	Receive threshold and error detection interrupts available Data stored in receive FIFO

**RS-485 Mode**

The RS-485 mode is intended to simplify the interface between the UART channel and an RS-485 driver or transceiver. When enabled by setting 485EN, the  $\overline{\text{DTRx}}$  output goes high one bit time before the first start bit of the first data byte being sent, and remains high as long as there is pending data in the transmitter shift register (TSR) or transmitter holding register (THR, xmt fifo). After both are empty (after the last stop bit of the last data byte), the  $\overline{\text{DTRx}}$  output stays high for a programmable delay of 0 to 15 bit times, as set by DLY[3:0]. This helps preserve data integrity over long signal lines. This is illustrated in the following.

Often RS-485 packets are relatively short and the entire packet can fit within the 64 byte xmt fifo. In this case, it goes empty when the TSR goes empty. But in cases where a larger block needs to be sent, it is advantageous to reload the xmt fifo as soon as it is depleted. Otherwise, the transmission stalls while waiting for the xmt fifo to be reloaded, which varies with processor load. In this case, it is best to also set 485LG (large block) which causes the transmit interrupt to occur wither when the THR becomes empty (if the xmt fifo level was not above the threshold), or when the xmt fifo threshold is crossed. The reloading of the xmt fifo occurs while some data is being shifted out, eliminating fifo underrun. If desired, when the last bytes of a current transmission are being loaded in the xmt fifo, 485LG can be cleared before the load and the transmit interrupt occurs on the TSR going empty.

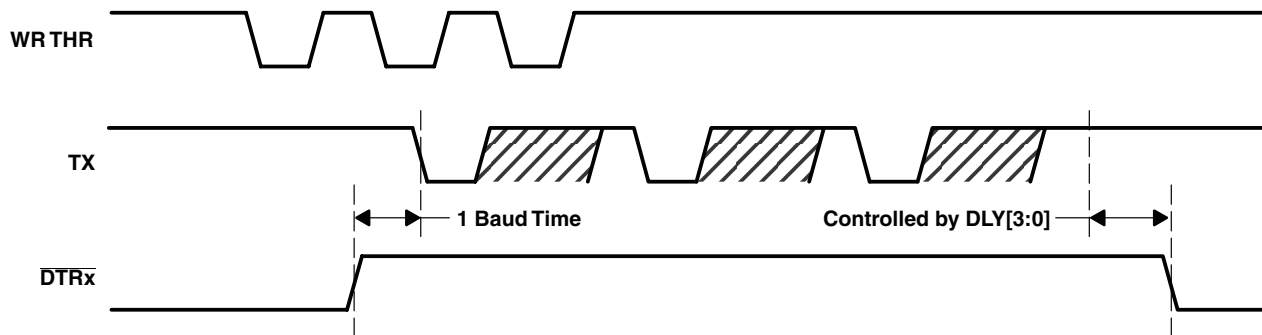

A. Waveforms are not shown to scale, as the WR THR pulses typically are less than 100 ns, where the TX waveform varies with baud rate but is typically in the microsecond range.

**Figure 23.  $\overline{\text{DTRx}}$  and Transmit Data Relationship**

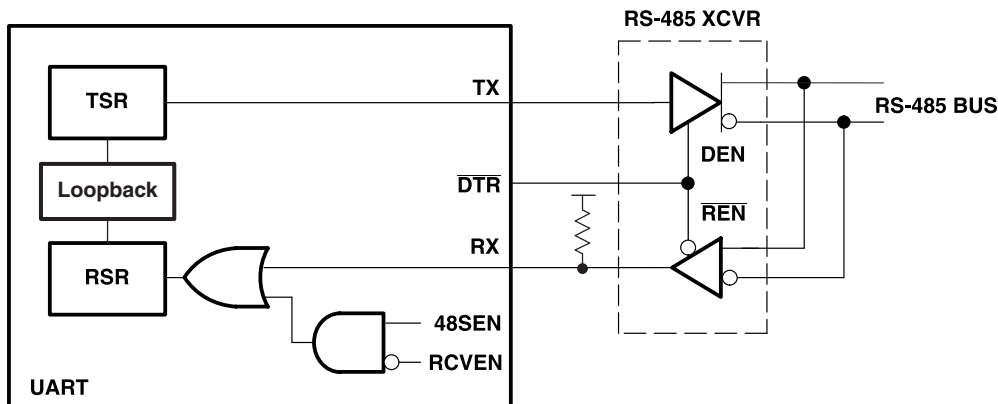

Figure 24. RS-485 Application Example 1

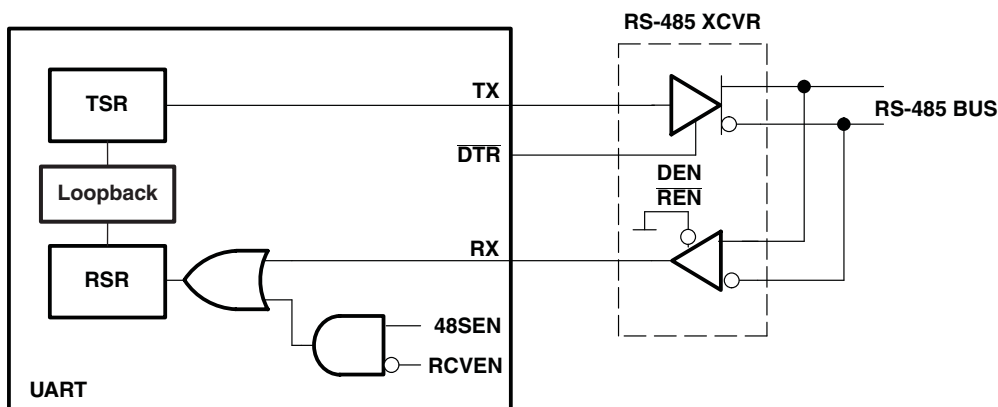

Figure 25. RS-485 Application Example 2

IrDA Overview

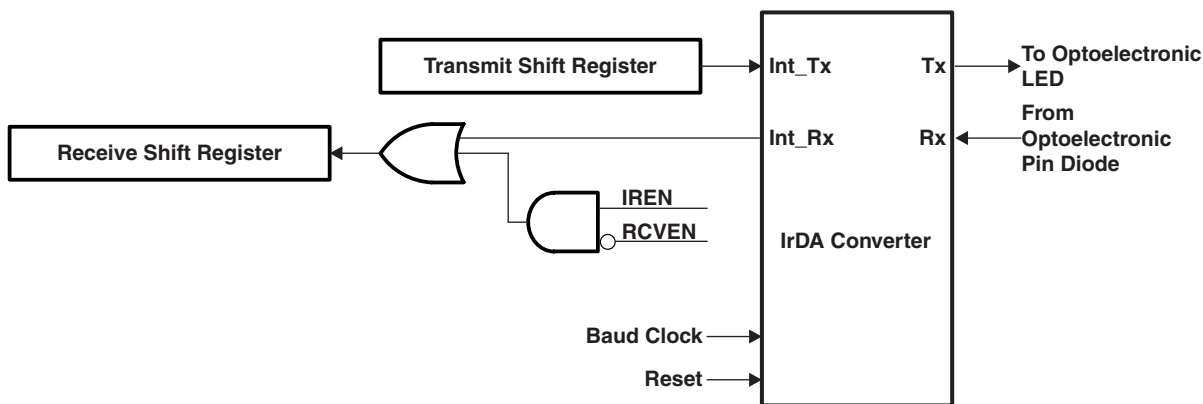

Figure 26. IrDA Mode

The IrDA defines several protocols for sending and receiving serial infrared data, including rates of 115.2 kbps, 0.576 Mbps, 1.152 Mbps, and 4 Mbps. The low rate of 115.2 kbps was specified first and the others must maintain downward compatibility with it. At the 115.2 kbps rate, the protocol implemented in the hardware is fairly simple. It primarily defines a serial infrared data word to be surrounded by a start bit equal to 0 and a stop bit equal to 1. Individual bits are encoded or decoded the same whether they are start, data, or stop bits. The IrDA engine in the '754C evaluate only single bits and only follow the 115.2-kbps protocol. The 115.2-kbps rate is a

maximum rate. When both ends of the transfer are setup to a lower but matching speed, the protocol still works. The clock used to code or sample the data is 16 times the baud rate, or 1.843 MHz maximum. To code a 1, no pulse is sent or received for 1-bit time period, or 16 clock cycles. To code a 0, one pulse is sent or received within a 1-bit time period, or 16 clock cycles. The pulse must be at least 1.6- $\mu$ s wide and 3 clock cycles long at 1.843 MHz. At lower baud rates the pulse can be 1.6  $\mu$ s wide or as long as 3 clock cycles. The transmitter output, Tx, is intended to drive a LED circuit to generate an infrared pulse. The LED circuits work on positive pulses. A terminal circuit is expected to create the receiver input, Rx. Most, but not all, PIN circuits have inversion and generate negative pulses from the detected infrared light. Their output is normally high. The '754C can decode either negative or positive pulses on Rx.

### IrDA Encoder Function

Serial data from a UART is encoded to transmit data to the optoelectronics. While the serial data input to this block (Int\_Tx) is high, the output (Tx) is always low, and the counter used to form a pulse on Tx is continuously cleared. After Int\_Tx resets to 0, Tx rises on the falling edge of the seventh 16XCLK. On the falling edge of the tenth 16XCLK pulse, Tx falls, creating a 3-clock-wide pulse. While Int\_Tx stays low, a pulse is transmitted during the seventh to tenth clocks of each 16-clock bit cycle.

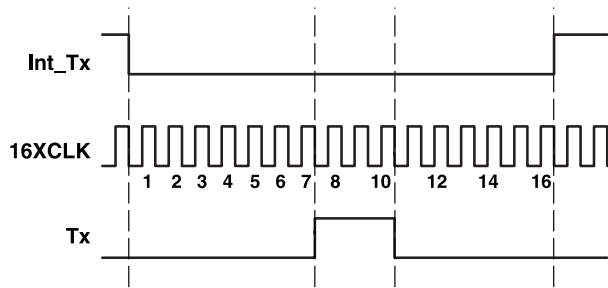

Figure 27. IrDA-SIR Encoding Scheme – Detailed Timing Diagram

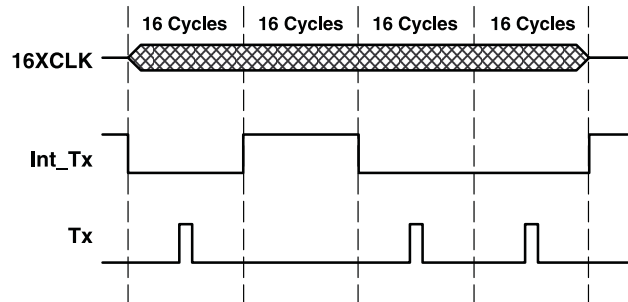

Figure 28. Encoding Scheme – Macro View

After reset, Int\_Rx is high and the 4-bit counter is cleared. When a falling edge is detected on Rx, Int\_Rx falls on the next rising edge of 16XCLK with sufficient setup time. Int\_Rx stays low for 16 cycles (16XCLK) and then returns to high as required by the IrDA specification. As long as no pulses (falling edges) are detected on Rx, Int\_Rx remains high.

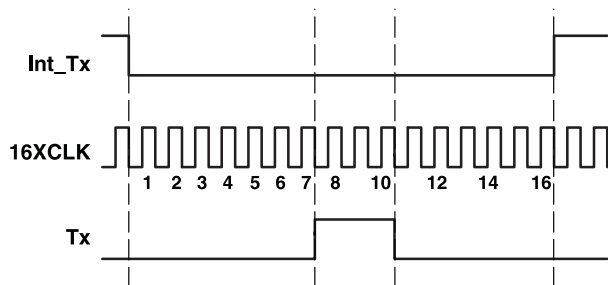

Figure 29. IrDA-SIR Decoding Scheme – Detailed Timing Diagram

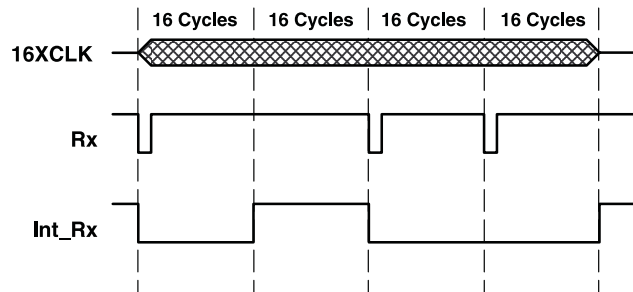

Figure 30. IrDA-SIR Decoding Scheme – Macro View

It is possible for jitter or slight frequency differences to cause the next falling edge on Rx to be missed for one 16XCLK cycle. In that case, a 1-clock-wide pulse appears on Int\_Rx between consecutive zeroes. It is important for the UART to strobe Int\_Rx in the middle of the bit time to avoid latching this 1-clock-wide pulse. The TL16C550C UART already strobbs incoming serial data at the proper time. Otherwise, note that data is required to be framed by a leading 0 and a trailing 1. The falling edge of that first 0 on Int\_Rx synchronizes the read strobe. The strobe occurs on the eighth 16XCLK pulse after the Int\_Rx falling edge and once every 16 cycles thereafter until the stop bit occurs.

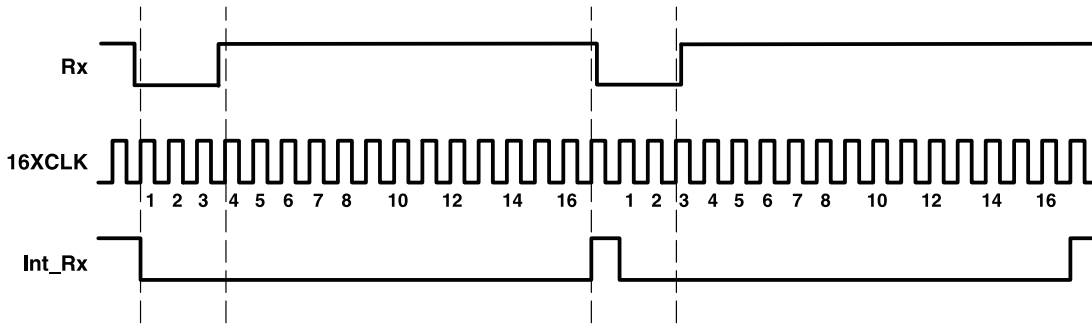

Figure 31. Timing Causing 1-Clock-Wide Pulse Between Consecutive Ones

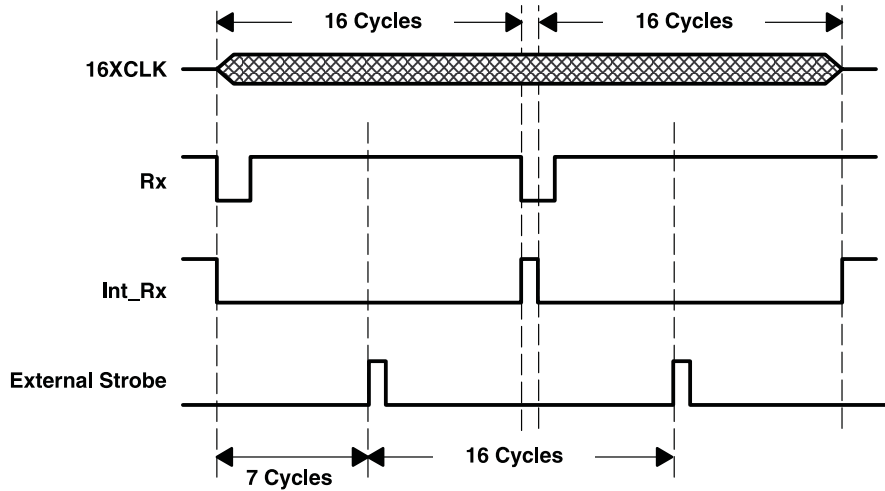

Figure 32. Recommended Strobing For Decoded Data

The '754C can decode positive pulses on Rx. The timing is different, but the variation is invisible to the UART. The decoder, which works from the falling edge, now recognizes a 0 on the trailing edge of the pulse rather than on the leading edge. As long as the pulse width is fairly constant, as defined by the specification, the trailing edges should also be 16 clock cycles apart and data can readily be decoded. The 0 appears on Int\_Rx after the pulse rather than at the start of it.

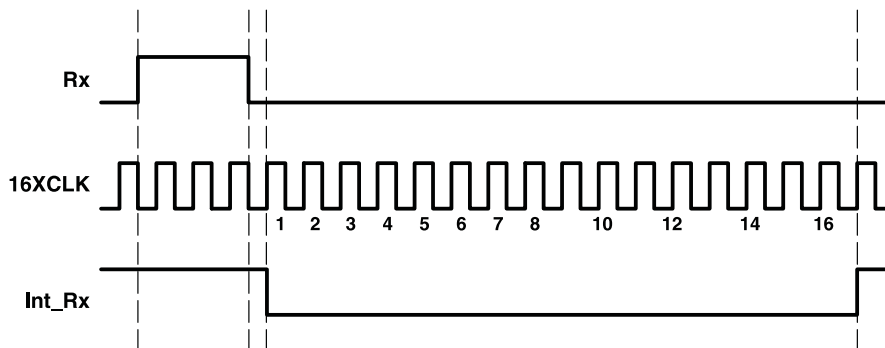

Figure 33. Positive Rx Pulse Decode – Detailed View

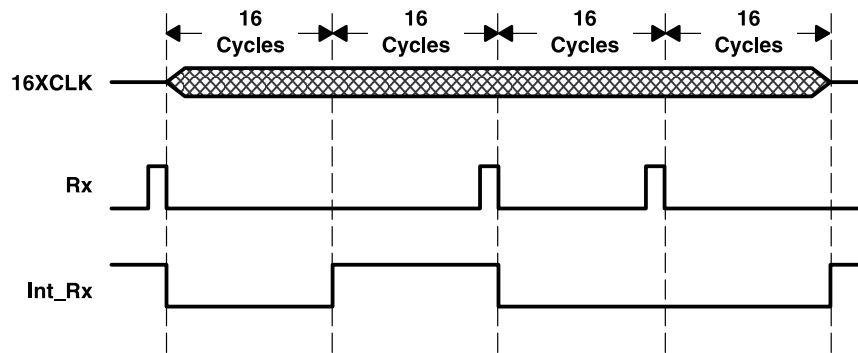
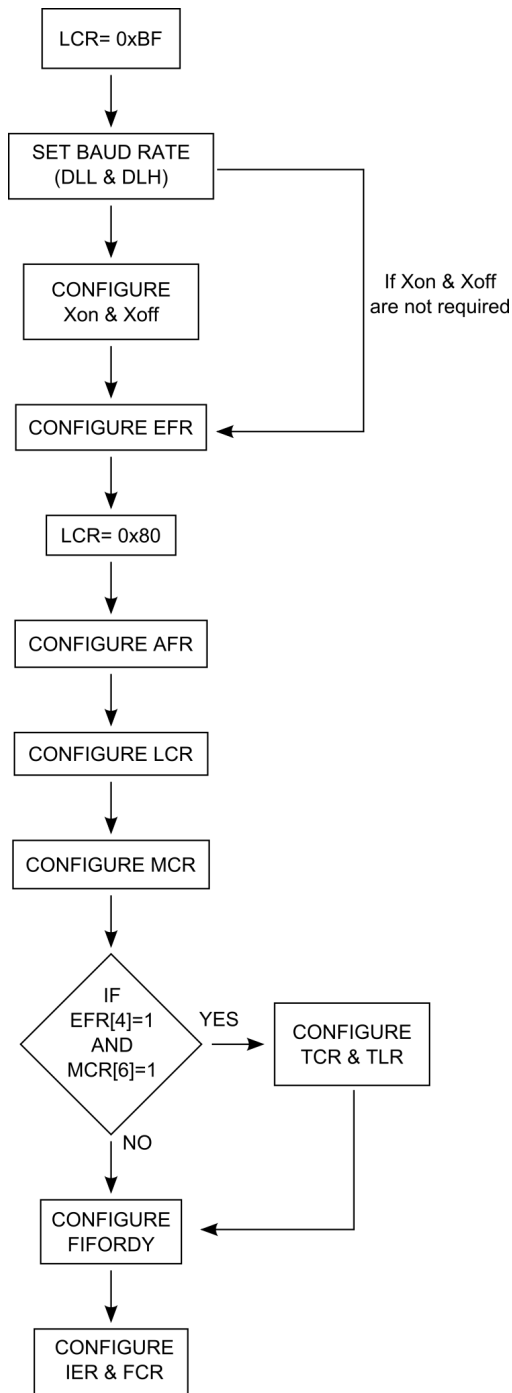

Figure 34. Positive Rx Pulse Decode – Macro View

## TL16CP754C Programmer's Guide

The base set of registers that are used during high-speed data transfer have a straightforward access method. The extended function registers require special access bits to be decoded along with the address lines. The following guide helps with programming these registers. Note that the descriptions are for individual register access. Some streamlining through interleaving can be obtained when programming all the registers.

Set baud rate to VALUE1,VALUE2	Read LCR (03), save in temp Set LCR (03) to 80 Set DLL (00) to VALUE1 Set DLM (01) to VALUE2 Set LCR (03) to temp
Set Xoff1,Xon1 to VALUE1,VALUE2	Read LCR (03), save in temp Set LCR (03) to BF Set Xoff1 (06) to VALUE1 Set Xon1 (04) to VALUE2 Set LCR (03) to temp
Set Xoff2,Xon2 to VALUE1,VALUE2	Read LCR (03), save in temp Set LCR (03) to BF Set Xoff2 (07) to VALUE1 Set Xon2 (05) to VALUE2 Set LCR (03) to temp
Set software flow control mode to VALUE	Read LCR (03), save in temp Set LCR (03) to BF Set EFR (02) to VALUE Set LCR (03) to temp
Set flow control threshold to VALUE	Read LCR (03), save in temp1 Set LCR (03) to BF Read EFR (02), save in temp2 Set EFR (02) to 10 + temp2 Set LCR (03) to 00 Read MCR (04), save in temp3 Set MCR (04) to 40 + temp3 Set TCR (06) to VALUE Set LCR (03) to BF Set EFR (02) to temp2 Set LCR (03) to temp1 Set MCR (04) to temp3
Set xmt and rcv FIFO thresholds to VALUE	Read LCR (03), save in temp1 Set LCR (03) to BF Read EFR (02), save in temp2 Set EFR (02) to 10 + temp2 Set LCR (03) to 00 Read MCR (04), save in temp3 Set MCR (04) to 40 + temp3 Set TLR (07) to VALUE Set LCR (03) to BF Set EFR (02) to temp2 Set LCR (03) to temp1 Set MCR (04) to temp3
Read FIFORdy register	Read MCR (04), save in temp1 Set temp2 = temp1 × EF Set MCR (04), save in temp2 Read FRR (07), save in temp2 Pass temp2 back to host Set MCR (04) to temp1



**Figure 35. Diagram of the Generic Configuration Process**

---

**REVISION HISTORY**

<b>Changes from Revision G (May 2011) to Revision H</b>	<b>Page</b>
• Added cross references to the IrDA section and the internal oscillator circuit .....	4
• Replaced the register map table with <a href="#">Figure 22</a> .....	28
• Updated <a href="#">Table 10</a> .....	29
• Added <a href="#">Figure 35</a> , a diagram of the generic configuration process .....	46

---

**PACKAGING INFORMATION**

Orderable Device	Status (1)	Package Type	Package Drawing	Pins	Package Qty	Eco Plan (2)	Lead finish/ Ball material (6)	MSL Peak Temp (3)	Op Temp (°C)	Device Marking (4/5)	Samples
TL16CP754CIPM	ACTIVE	LQFP	PM	64	160	RoHS & Green	NIPDAU	Level-3-260C-168 HR	-40 to 85	TL16CP754CI	<a href="#">Samples</a>
TL16CP754CIPMG4	ACTIVE	LQFP	PM	64	160	RoHS & Green	NIPDAU	Level-3-260C-168 HR	-40 to 85	TL16CP754CI	<a href="#">Samples</a>
TL16CP754CIPMR	ACTIVE	LQFP	PM	64	1000	RoHS & Green	NIPDAU	Level-3-260C-168 HR	-40 to 85	TL16CP754CI	<a href="#">Samples</a>
TL16CP754CIPMRG4	ACTIVE	LQFP	PM	64	1000	RoHS & Green	NIPDAU	Level-3-260C-168 HR	-40 to 85	TL16CP754CI	<a href="#">Samples</a>
TL16CP754CPM	ACTIVE	LQFP	PM	64	160	RoHS & Green	NIPDAU	Level-3-260C-168 HR	0 to 70	TL16CP754C	<a href="#">Samples</a>
TL16CP754CPMR	ACTIVE	LQFP	PM	64	1000	RoHS & Green	NIPDAU	Level-3-260C-168 HR	0 to 70	TL16CP754C	<a href="#">Samples</a>

(1) The marketing status values are defined as follows:

**ACTIVE:** Product device recommended for new designs.

**LIFEBUY:** TI has announced that the device will be discontinued, and a lifetime-buy period is in effect.

**NRND:** Not recommended for new designs. Device is in production to support existing customers, but TI does not recommend using this part in a new design.

**PREVIEW:** Device has been announced but is not in production. Samples may or may not be available.

**OBSOLETE:** TI has discontinued the production of the device.

(2) **RoHS:** TI defines "RoHS" to mean semiconductor products that are compliant with the current EU RoHS requirements for all 10 RoHS substances, including the requirement that RoHS substance do not exceed 0.1% by weight in homogeneous materials. Where designed to be soldered at high temperatures, "RoHS" products are suitable for use in specified lead-free processes. TI may reference these types of products as "Pb-Free".

**RoHS Exempt:** TI defines "RoHS Exempt" to mean products that contain lead but are compliant with EU RoHS pursuant to a specific EU RoHS exemption.

**Green:** TI defines "Green" to mean the content of Chlorine (Cl) and Bromine (Br) based flame retardants meet JS709B low halogen requirements of <=1000ppm threshold. Antimony trioxide based flame retardants must also meet the <=1000ppm threshold requirement.

(3) MSL, Peak Temp. - The Moisture Sensitivity Level rating according to the JEDEC industry standard classifications, and peak solder temperature.

(4) There may be additional marking, which relates to the logo, the lot trace code information, or the environmental category on the device.

(5) Multiple Device Markings will be inside parentheses. Only one Device Marking contained in parentheses and separated by a "~" will appear on a device. If a line is indented then it is a continuation of the previous line and the two combined represent the entire Device Marking for that device.

(6) Lead finish/Ball material - Orderable Devices may have multiple material finish options. Finish options are separated by a vertical ruled line. Lead finish/Ball material values may wrap to two lines if the finish value exceeds the maximum column width.

**Important Information and Disclaimer:** The information provided on this page represents TI's knowledge and belief as of the date that it is provided. TI bases its knowledge and belief on information provided by third parties, and makes no representation or warranty as to the accuracy of such information. Efforts are underway to better integrate information from third parties. TI has taken and continues to take reasonable steps to provide representative and accurate information but may not have conducted destructive testing or chemical analysis on incoming materials and chemicals. TI and TI suppliers consider certain information to be proprietary, and thus CAS numbers and other limited information may not be available for release.

In no event shall TI's liability arising out of such information exceed the total purchase price of the TI part(s) at issue in this document sold by TI to Customer on an annual basis.

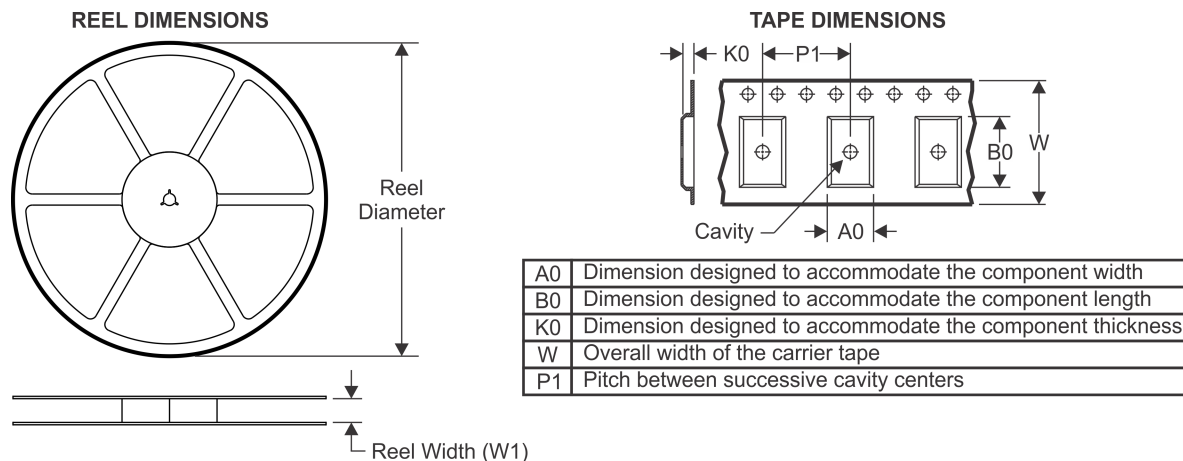
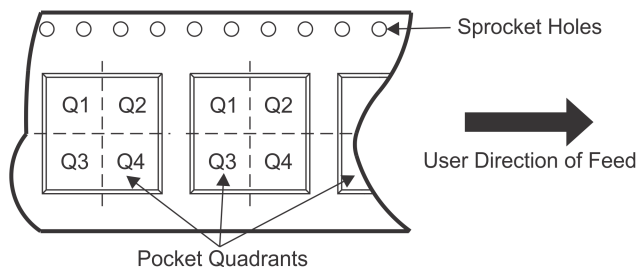
**TAPE AND REEL INFORMATION**

**QUADRANT ASSIGNMENTS FOR PIN 1 ORIENTATION IN TAPE**

\*All dimensions are nominal

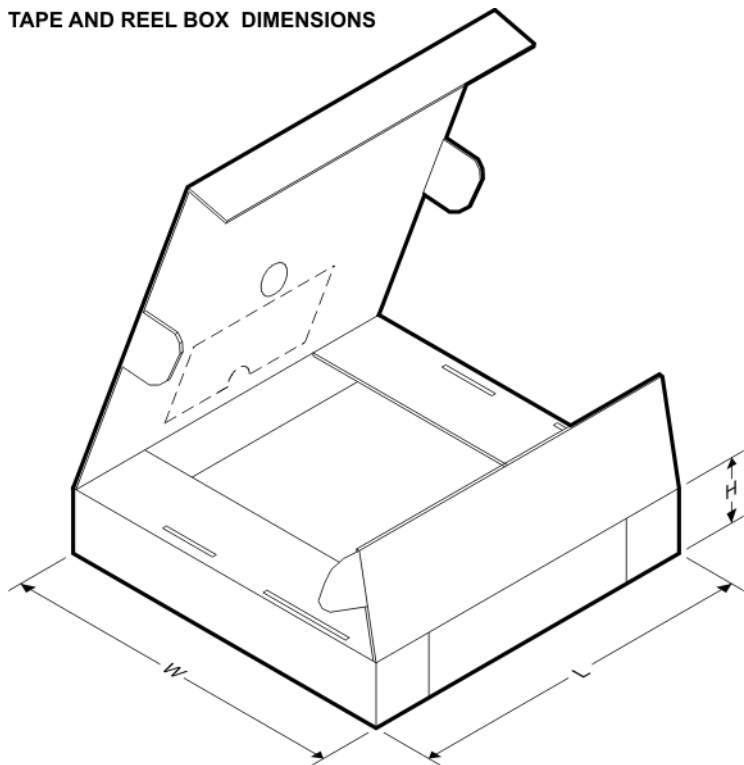
Device	Package Type	Package Drawing	Pins	SPQ	Reel Diameter (mm)	Reel Width W1 (mm)	A0 (mm)	B0 (mm)	K0 (mm)	P1 (mm)	W (mm)	Pin1 Quadrant
TL16CP754CIPMR	LQFP	PM	64	1000	330.0	24.4	13.0	13.0	2.1	16.0	24.0	Q2
TL16CP754CPMR	LQFP	PM	64	1000	330.0	24.4	13.0	13.0	2.1	16.0	24.0	Q2

**TAPE AND REEL BOX DIMENSIONS**

\*All dimensions are nominal

Device	Package Type	Package Drawing	Pins	SPQ	Length (mm)	Width (mm)	Height (mm)
TL16CP754CIPMR	LQFP	PM	64	1000	336.6	336.6	41.3
TL16CP754CPMR	LQFP	PM	64	1000	336.6	336.6	41.3

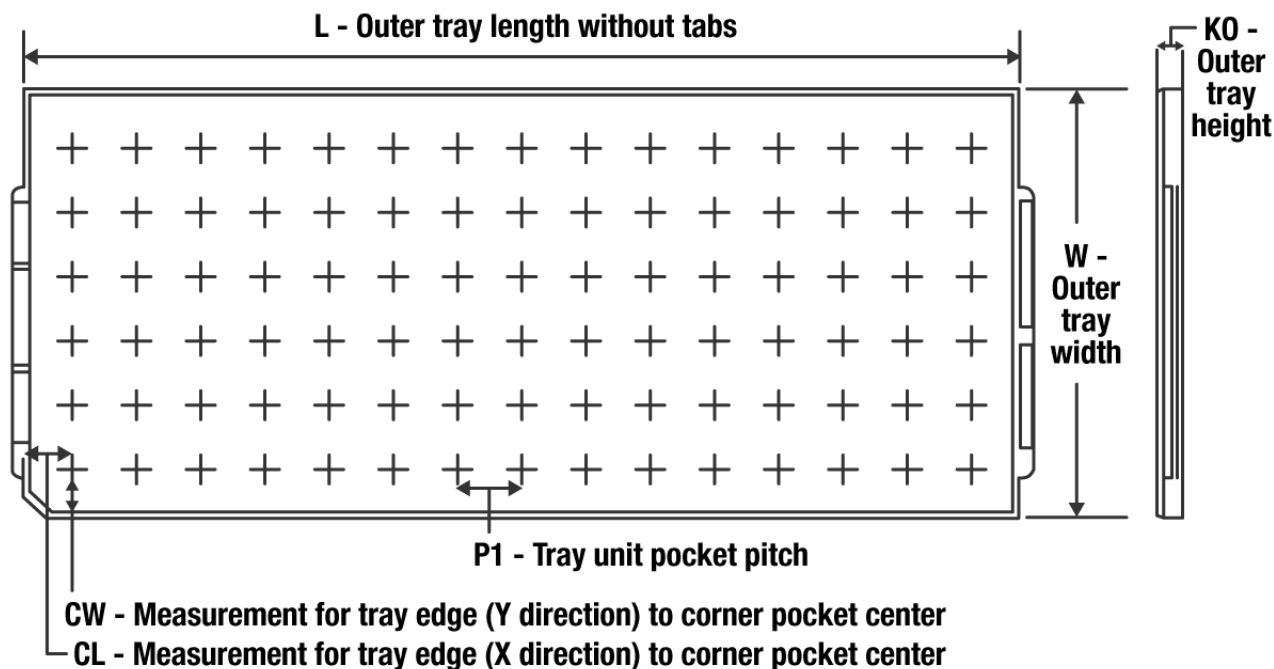
**TRAY**

Chamfer on Tray corner indicates Pin 1 orientation of packed units.

\*All dimensions are nominal

Device	Package Name	Package Type	Pins	SPQ	Unit array matrix	Max temperature (°C)	L (mm)	W (mm)	K0 (µm)	P1 (mm)	CL (mm)	CW (mm)
TL16CP754CIPM	PM	LQFP	64	160	8 X 20	150	315	135.9	7620	15.2	13.1	13
TL16CP754CIPMG4	PM	LQFP	64	160	8 X 20	150	315	135.9	7620	15.2	13.1	13
TL16CP754CPM	PM	LQFP	64	160	8 X 20	150	315	135.9	7620	15.2	13.1	13

# PM0064A

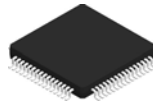

## PACKAGE OUTLINE

LQFP - 1.6 mm max height

PLASTIC QUAD FLATPACK

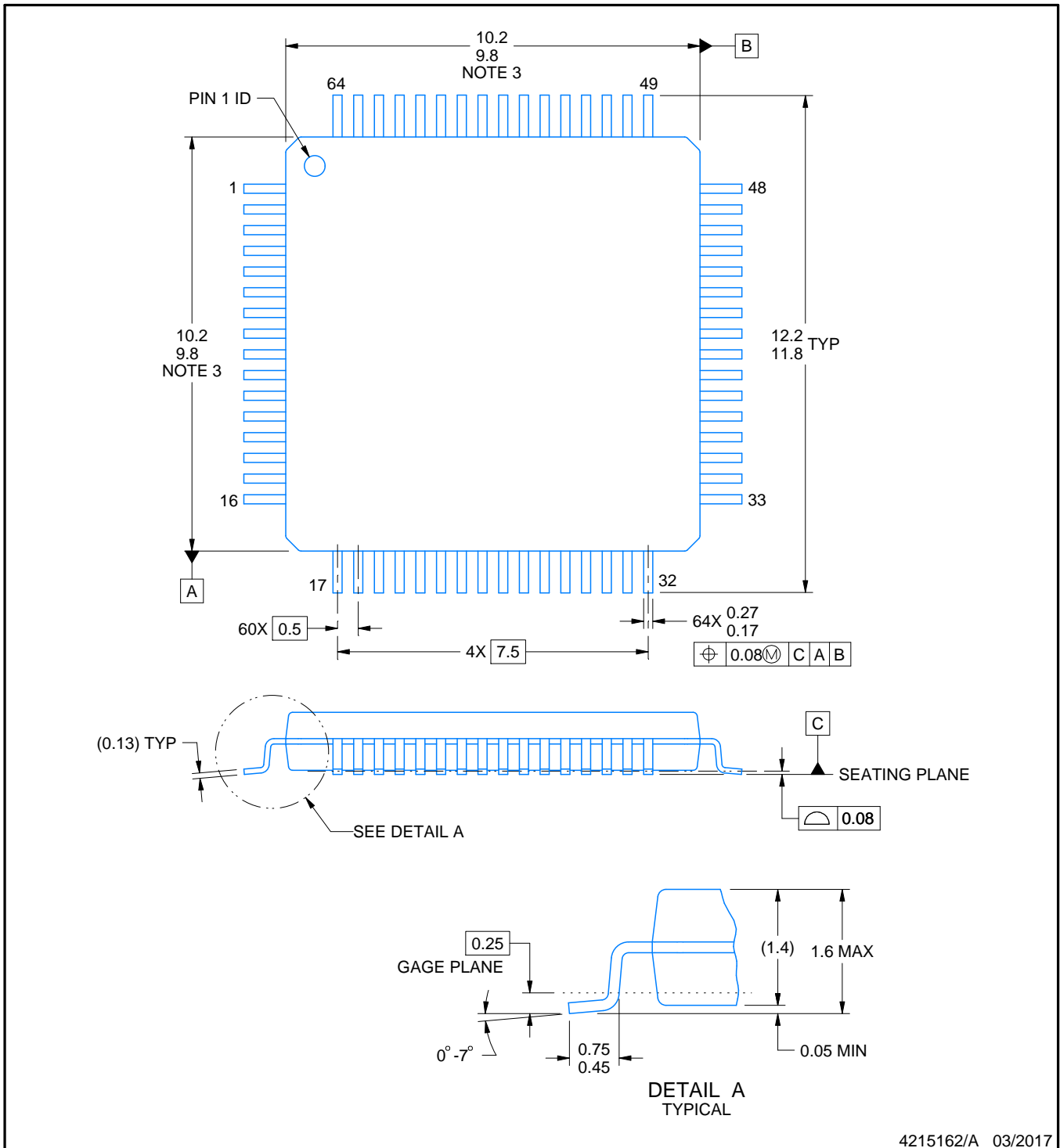

4215162/A 03/2017

### NOTES:

1. All linear dimensions are in millimeters. Any dimensions in parenthesis are for reference only. Dimensioning and tolerancing per ASME Y14.5M.
2. This drawing is subject to change without notice.
3. This dimension does not include mold flash, protrusions, or gate burrs. Mold flash, protrusions, or gate burrs shall not exceed 0.15 mm per side.
4. Reference JEDEC registration MS-026.

# EXAMPLE BOARD LAYOUT

PM0064A

LQFP - 1.6 mm max height

PLASTIC QUAD FLATPACK

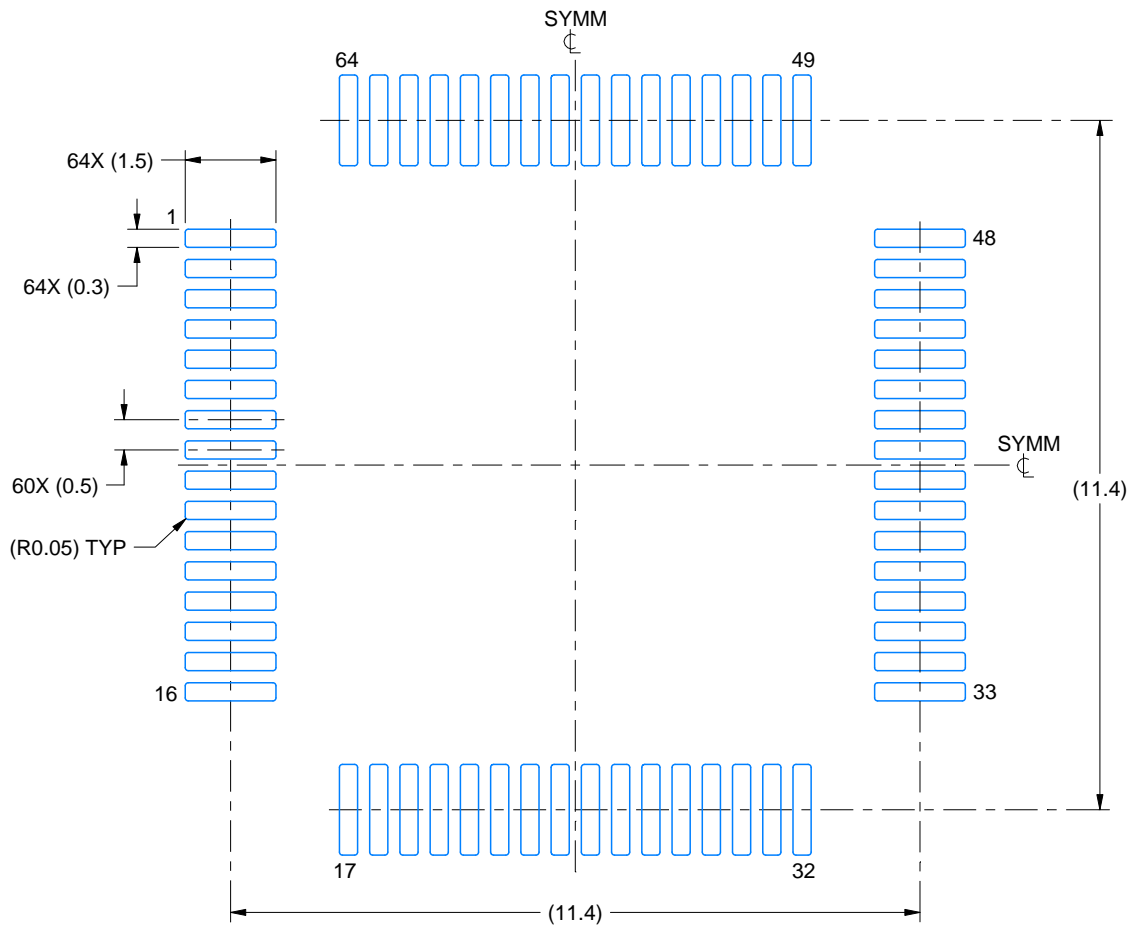

LAND PATTERN EXAMPLE  
EXPOSED METAL SHOWN  
SCALE:8X

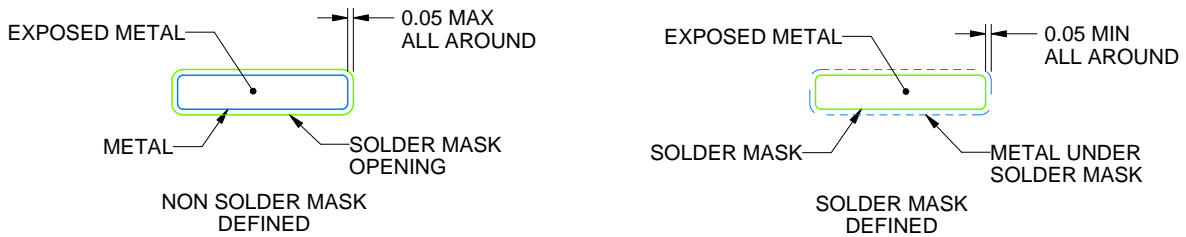

SOLDER MASK DETAILS

4215162/A 03/2017

NOTES: (continued)

5. Publication IPC-7351 may have alternate designs.
6. Solder mask tolerances between and around signal pads can vary based on board fabrication site.
7. For more information, see Texas Instruments literature number SLMA004 ([www.ti.com/lit/slma004](http://www.ti.com/lit/slma004)).

# EXAMPLE STENCIL DESIGN

PM0064A

LQFP - 1.6 mm max height

PLASTIC QUAD FLATPACK

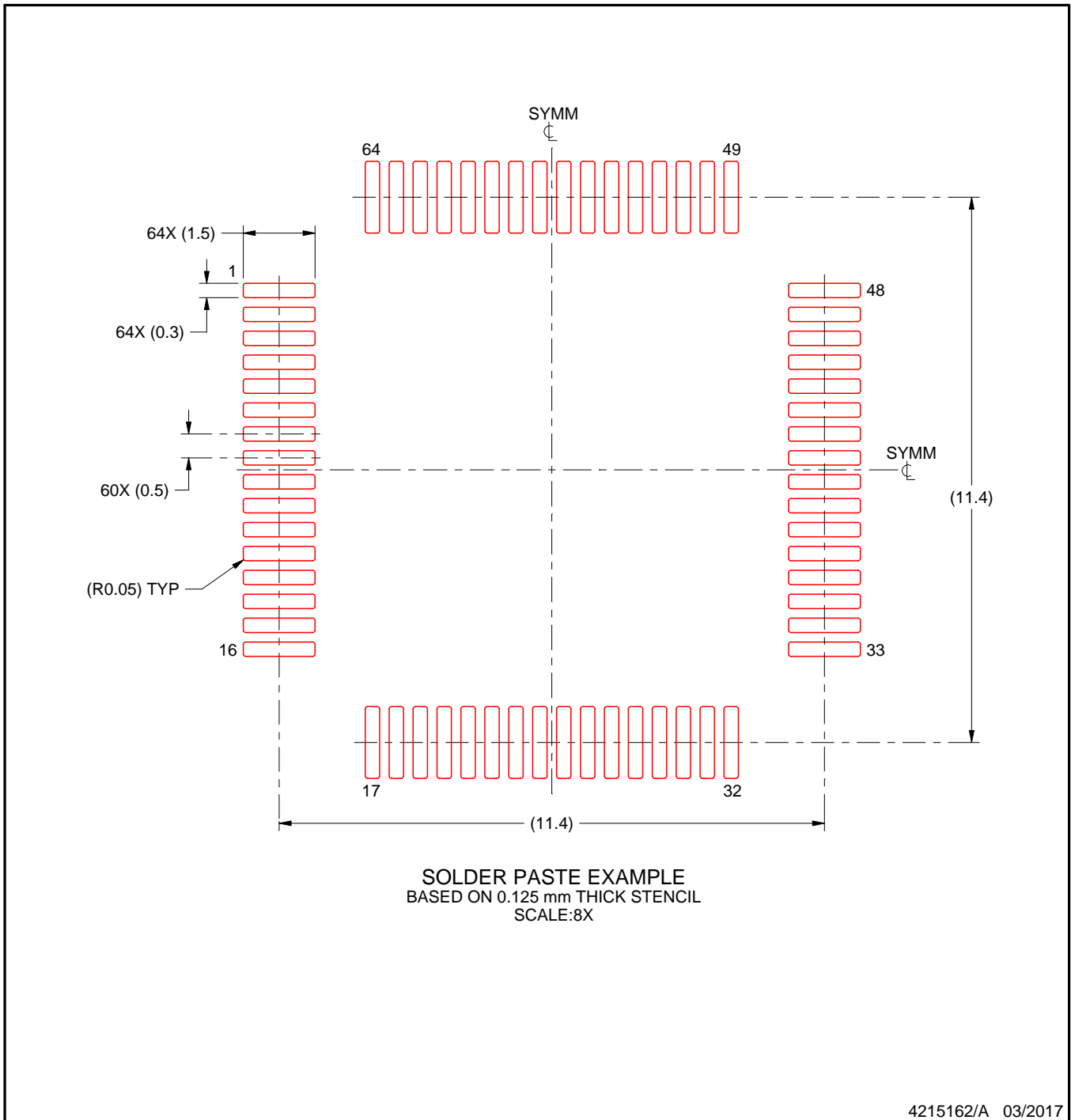

NOTES: (continued)

8. Laser cutting apertures with trapezoidal walls and rounded corners may offer better paste release. IPC-7525 may have alternate design recommendations.
9. Board assembly site may have different recommendations for stencil design.

## IMPORTANT NOTICE AND DISCLAIMER

TI PROVIDES TECHNICAL AND RELIABILITY DATA (INCLUDING DATA SHEETS), DESIGN RESOURCES (INCLUDING REFERENCE DESIGNS), APPLICATION OR OTHER DESIGN ADVICE, WEB TOOLS, SAFETY INFORMATION, AND OTHER RESOURCES "AS IS" AND WITH ALL FAULTS, AND DISCLAIMS ALL WARRANTIES, EXPRESS AND IMPLIED, INCLUDING WITHOUT LIMITATION ANY IMPLIED WARRANTIES OF MERCHANTABILITY, FITNESS FOR A PARTICULAR PURPOSE OR NON-INFRINGEMENT OF THIRD PARTY INTELLECTUAL PROPERTY RIGHTS.

These resources are intended for skilled developers designing with TI products. You are solely responsible for (1) selecting the appropriate TI products for your application, (2) designing, validating and testing your application, and (3) ensuring your application meets applicable standards, and any other safety, security, regulatory or other requirements.

These resources are subject to change without notice. TI grants you permission to use these resources only for development of an application that uses the TI products described in the resource. Other reproduction and display of these resources is prohibited. No license is granted to any other TI intellectual property right or to any third party intellectual property right. TI disclaims responsibility for, and you will fully indemnify TI and its representatives against, any claims, damages, costs, losses, and liabilities arising out of your use of these resources.

TI's products are provided subject to [TI's Terms of Sale](#) or other applicable terms available either on [ti.com](http://ti.com) or provided in conjunction with such TI products. TI's provision of these resources does not expand or otherwise alter TI's applicable warranties or warranty disclaimers for TI products.

TI objects to and rejects any additional or different terms you may have proposed.

Mailing Address: Texas Instruments, Post Office Box 655303, Dallas, Texas 75265  
Copyright © 2022, Texas Instruments Incorporated

## Looking for pricing, stock, or lifecycle information?

Click below to explore more details on WIN SOURCE:

 [View TL16CP754CIPM](#) on WIN SOURCE

 [Texas Instruments](#) Information

## Optimize Your Supply Chain with WIN SOURCE Solutions

-  Global Sourcing Solution
-  Obsolete Management
-  Cost Control Management
-  Shortage Management
-  Alternative Solution
-  Excess Inventory Management