



THE DATASHEET OF
2933



REV.	DESCRIPTION/ECO NO.	DATE
	RELEASED AS CAD	8/26/02
A	CHANGE MECH. ART	7/24/06
B	CHANGE CONTACT DIMENSION	8/18/06
C	CHANGE DIM. 5 TO 4.3 REF.	2/5/07
D	ADD DIM. 15.7±0.1	1/5/17
E	ADD SOLDER PAD	2/15/17

P.C. BOARD PUNCH PATTERN

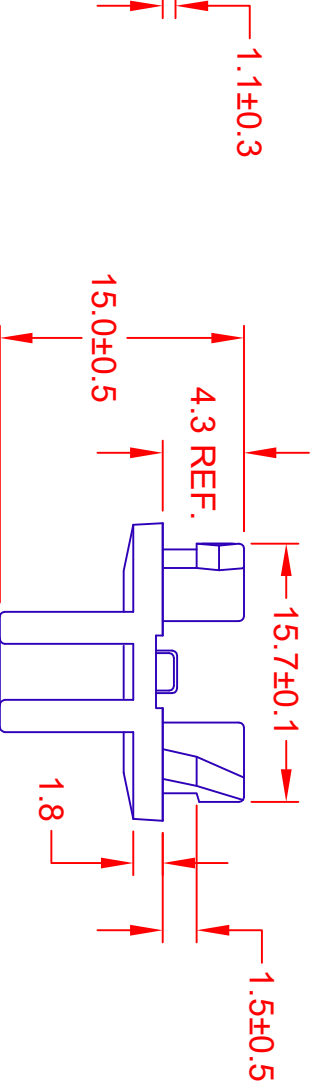
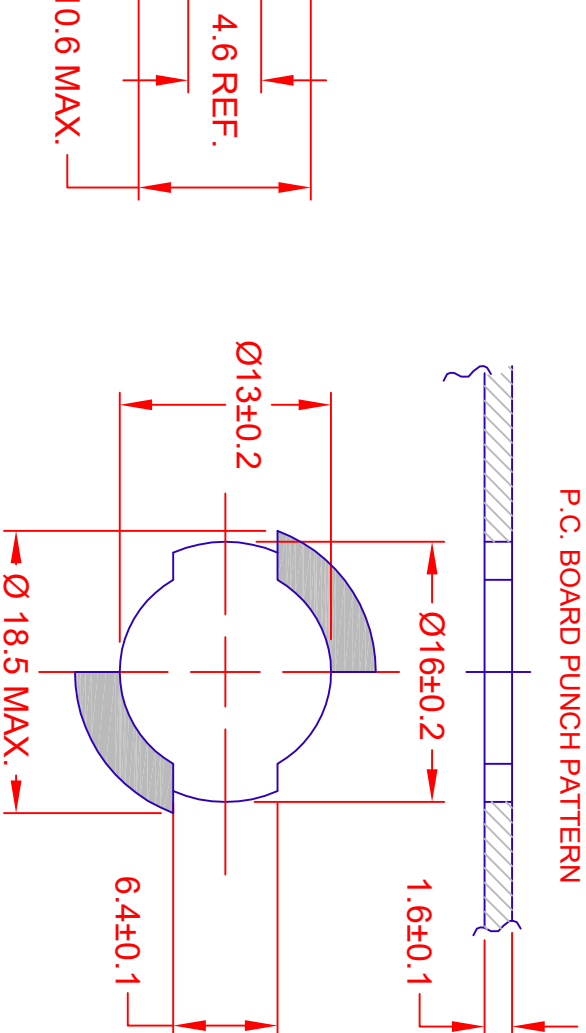

BASE COLOR: BLACK

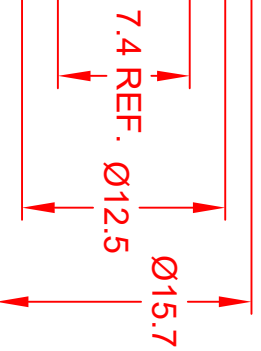

METRIC		DIMENSIONS ARE IN MILLIMETERS		TITLE	
 THIRD ANGLE PROJECTION		TOLERANCE UNLESS OTHERWISE SPECIFIED 1 PL +/- .02 2 PL +/- .020 ANGLE +/- .0		JKL COMPONENTS CORPORATION T-3 1/4 WEDGE BASE LAMP SOCKET	
DRAWN BY L. WENGSTROM	APPR'D BY L.R.	DATE 2/15/17	SIZE A	FSCM NO. 55335	DRAWING NO.
- CAD DRAWING - MANUAL REVISIONS NOT PERMITTED			SCALE NONE	RELEASED DATE 8/26/02	REVISION DATE 2/15/17
			REV. NO. E	SHEET 1 OF 1	

Looking for pricing, stock, or lifecycle information?

Click below to explore more details on WIN SOURCE:

- ⊖ [View 2933 on WIN SOURCE](#)
- ⊖ [JKL Components Corp. Information](#)

Optimize Your Supply Chain with WIN SOURCE Solutions

- ✓ Global Sourcing Solution
- ✓ Obsolete Management
- ✓ Cost Control Management
- ✓ Shortage Management
- ✓ Alternative Solution
- ✓ Excess Inventory Management