



**THE DATASHEET OF
AM26LV31EIDRG4**



AM26LV31E Low-Voltage High-Speed Quadruple Differential Line Driver With $\pm 15\text{kV}$ IEC ESD Protection

1 Features

- Meets or exceeds standards TIA/EIA-422-B and ITU recommendation V.11
- Operates from a single 3.3V power supply
- ESD Protection for RS422 bus pins
 - $\pm 15\text{-kV}$ Human-body model (HBM)
 - $\pm 8\text{-kV}$ IEC61000-4-2, Contact discharge
 - $\pm 15\text{-kV}$ IEC61000-4-2, Air-gap discharge
- Switching rates up to 32MHz
- Propagation delay time: 8ns typical
- Pulse skew time: 500ps typical
- High output-drive current: $\pm 30\text{mA}$
- Controlled rise and fall times: 5ns typical
- Differential output voltage with 100Ω load: 2.6V typical
- Accepts 5V logic inputs with 3.3V supply
- I_{off} supports partial-power-down mode operation
- Driver output short-protection circuit
- Glitch-free power-up and power-down protection
- Package options: SO, SOIC, TSSOP, VQFN

2 Applications

- Motor drives
- Space avionics and defense
- Medical healthcare and fitness
- Wireless infrastructure
- Factory automation and control

3 Description

The AM26LV31E is a quadruple differential line driver with 3-state outputs. This driver has $\pm 15\text{kV}$ ESD (HBM and IEC61000-4-2, Air-Gap Discharge) and $\pm 8\text{kV}$ ESD (IEC61000-4-2, Contact Discharge) protection. This device is designed to meet TIA/EIA-422-B and ITU Recommendation V.11 drivers with reduced supply voltage.

The device is optimized for balanced-bus transmission at switching rates up to 32MHz. The outputs have high current capability for driving balanced lines, such as twisted-pair transmission lines, and provide a high impedance in the power-off condition.

The AM26LV31EI is characterized for operation from -40°C to $+85^\circ\text{C}$.

Package Information

PART NUMBER	PACKAGE ⁽¹⁾	PACKAGE SIZE ⁽²⁾
AM26LV31E	SOIC (D, 16)	9.9mm × 6mm
	SO (NS, 16)	10.2mm × 7.8mm
	TSSOP (PW, 16)	5mm × 6.4mm
	VQFN (RGY, 16)	4mm × 3.5mm

(1) For more information, see [Section 11](#).

(2) The package size (length × width) is a nominal value and includes pins, where applicable.

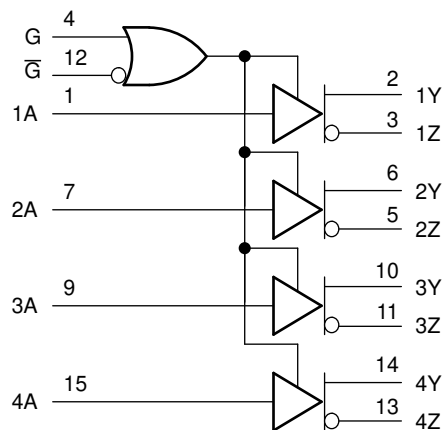

Copyright © 2016, Texas Instruments Incorporated

Logic Diagram



Table of Contents

1 Features	1	7.4 Device Functional Modes.....	11
2 Applications	1	8 Application and Implementation	12
3 Description	1	8.1 Application Information.....	12
4 Pin Configuration and Functions	3	8.2 Typical Application.....	12
5 Specifications	4	8.3 Power Supply Recommendations.....	13
5.1 Absolute Maximum Ratings.....	4	8.4 Layout.....	13
5.2 ESD Ratings.....	4	9 Device and Documentation Support	15
5.3 Recommended Operating Conditions.....	4	9.1 Documentation Support.....	15
5.4 Thermal Information.....	5	9.2 Receiving Notification of Documentation Updates....	15
5.5 Electrical Characteristics.....	5	9.3 Support Resources.....	15
5.6 Switching Characteristics.....	6	9.4 Trademarks.....	15
5.7 Typical Characteristics.....	6	9.5 Electrostatic Discharge Caution.....	15
6 Parameter Measurement Information	7	9.6 Glossary.....	15
7 Detailed Description	10	10 Revision History	15
7.1 Overview.....	10	11 Mechanical, Packaging, and Orderable Information	16
7.2 Functional Block Diagram.....	10		
7.3 Feature Description.....	10		

4 Pin Configuration and Functions

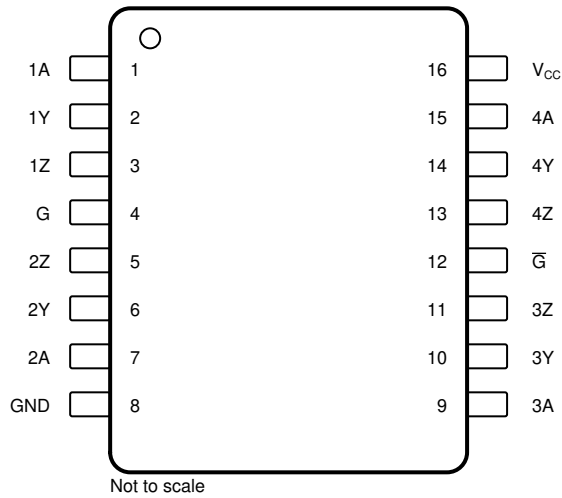

Not to scale
**Figure 4-1. D, NS, or PW Package
16-Pin SOIC, SO, TSSOP
(Top View)**

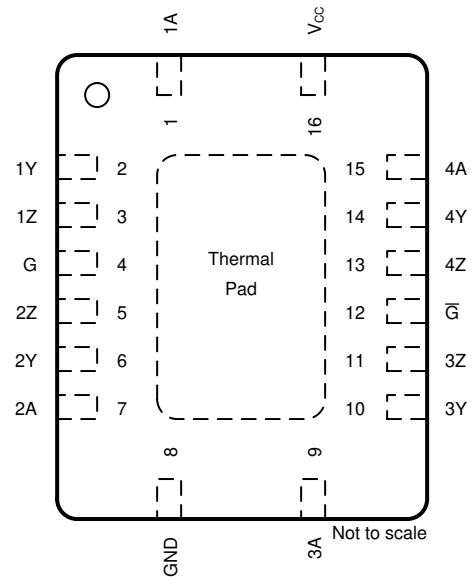

**Figure 4-2. RGY Package
16-Pin VQFN With Thermal Pad
(Top View)**

Table 4-1. Pin Functions

PIN		TYPE	DESCRIPTION
NAME	NO.		
1A	1	I	Logic data input to RS422 driver 1
1Y	2	O	RS-422 data line for driver 1
1Z	3	O	RS-422 data line for driver 1
2A	7	I	Logic data input to RS422 driver 2
2Y	6	O	RS-422 data line for driver 2
2Z	5	O	RS-422 data line for driver 2
3A	9	I	Logic data input to RS422 driver 3
3Y	10	O	RS-422 data line for driver 3
3Z	11	O	RS-422 data line for driver 3
4A	15	I	Logic data input to RS422 driver 4
4Y	14	O	RS-422 data line for driver 4
4Z	13	O	RS-422 data line for driver 4
G	4	I	Driver enable (active high)
Ḡ	12	I	Driver enable (active low)
GND	8	—	Device ground pin
V _{CC}	16	—	Power input (5V)

5 Specifications

5.1 Absolute Maximum Ratings

over operating free-air temperature range (unless otherwise noted)⁽¹⁾

		MIN	MAX	UNIT
V _{CC}	Supply voltage ⁽²⁾	-0.5	6	V
V _I	Input voltage	-0.5	6	V
V _O	Output voltage	-0.5	6	V
I _{IK}	Input clamp current	V _I < 0	-20	mA
I _{OK}	Output clamp current	V _O < 0	-20	mA
I _O	Continuous output current		±150	mA
	Continuous current through V _{CC} or GND		±200	mA
T _J	Operating virtual junction temperature		150	°C
T _A	Operating free-air temperature	-40	85	°C
T _{stg}	Storage temperature	-65	150	°C

- (1) Stresses beyond those listed under *Absolute Maximum Ratings* may cause permanent damage to the device. These are stress ratings only, which do not imply functional operation of the device at these or any other conditions beyond those indicated under *Recommended Operating Conditions*. Exposure to absolute-maximum-rated conditions for extended periods may affect device reliability.
- (2) All voltage values except differential input voltage are with respect to the network GND.

5.2 ESD Ratings

			VALUE	UNIT		
V _(ESD)	Electrostatic discharge	Human-body model (HBM), per ANSI/ESDA/JEDEC JS-001 ⁽¹⁾	Bus pins 2, 3, 5, 6, 10, 11, 13, and 14	±15000	V	
			All pins except 2, 3, 5, 6, 10, 11, 13, and 14	±2000		
		Charged-device model (CDM), per JEDEC specification JESD22-C101 ⁽²⁾		±1000		
			IEC 61000-4-2 contact discharge	Bus pins 2, 3, 5, 6, 10, 11, 13, and 14		±8000
			IEC 61000-4-2 air-gap discharge	Bus pins 2, 3, 5, 6, 10, 11, 13, and 14		±15000

- (1) JEDEC document JEP155 states that 500V HBM allows safe manufacturing with a standard ESD control process.
- (2) JEDEC document JEP157 states that 250V CDM allows safe manufacturing with a standard ESD control process.

5.3 Recommended Operating Conditions

		MIN	NOM	MAX	UNIT
V _{CC}	Supply voltage	3	3.3	3.6	V
V _I	Input voltage	0		5.5	V
V _{IH}	High-level input voltage	2			V
V _{IL}	Low-level input voltage			0.8	V
I _{OH}	High-level output current			-30	mA
I _{OL}	Low-level output current			30	mA
T _A	Operating free-air temperature	-40		85	°C

5.4 Thermal Information

THERMAL METRIC ⁽¹⁾		AM26LV31E				UNIT
		D (SOIC)	PW (TSSOP)	NS (SO)	RGY (VQFN)	
		16 PINS	16 PINS	16 PINS	16 PINS	
R _{θJA}	Junction-to-ambient thermal resistance	84.6	107.5	88.5	48.4	°C/W
R _{θJC(top)}	Junction-to-case (top) thermal resistance	43.5	38.4	46.2	46.8	°C/W
R _{θJB}	Junction-to-board thermal resistance	43.2	53.7	50.7	24.6	°C/W
ψ _{JT}	Junction-to-top characterization parameter	10.4	3.2	13.5	2.3	°C/W
ψ _{JB}	Junction-to-board characterization parameter	42.8	53.1	50.3	24.5	°C/W
R _{θJC(bot)}	Junction-to-case (bottom) thermal resistance	n/a	n/a	n/a	8.5	°C/W

(1) For more information about traditional and new thermal metrics, see the [Semiconductor and IC Package Thermal Metrics](#) application report.

5.5 Electrical Characteristics

over recommended ranges of supply voltage and operating free-air temperature (unless otherwise noted)

PARAMETER		TEST CONDITIONS	MIN	TYP ⁽¹⁾	MAX	UNIT
V _{OH}	High-level output voltage	V _{IH} = 2V, V _{IL} = 0.8V, I _{OH} = -20mA	2.4	3		V
V _{OL}	Low-level output voltage	V _{IH} = 2V, V _{IL} = 0.8V, I _{OL} = 20mA		0.2	0.4	V
V _{OD1}	Differential output voltage	I _O = 0mA	2		4	V
V _{OD2}	Differential output voltage	R _L = 100Ω (see Figure 6-1)	2	2.6		V
Δ V _{OD}	Change in magnitude of differential output voltage	R _L = 100Ω (see Figure 6-1)			±0.4	V
V _{OC}	Common-mode output voltage	R _L = 100Ω (see Figure 6-1)		1.5	2	V
Δ V _{OC}	Change in magnitude of common-mode output voltage	R _L = 100Ω (see Figure 6-1)			±0.4	V
I _{O(OFF)}	Output current with power off	V _{CC} = 0, V _O = -0.25V or 5.5V			±100	μA
I _{OZ}	High-impedance state output current	V _O = -0.25V or 5.5V, G = 0.8V or \bar{G} = 2V			±100	μA
I _I	Input current	V _{CC} = 0 or 3.6V, V _I = 0 or 5.5V			±10	μA
I _{OS}	Short-circuit output current	V _O = V _{CC} or GND ⁽²⁾	-30		-150	mA
I _{CC}	Supply current (total package)	V _I = V _{CC} or GND, No load, enable			100	μA
C _{pd}	Power dissipation capacitance	No load ⁽³⁾		160		pF

- (1) All typical values are at V_{CC} = 3.3V, T_A = 25°C.
(2) Not more than one output should be shorted at a time, and the duration of the short circuit should not exceed one second.
(3) C_{pd} determines the no-load dynamic current consumption. I_S = C_{pd} × V_{CC} × f + I_{CC}

5.6 Switching Characteristics

over recommended ranges of supply voltage and operating free-air temperature (unless otherwise noted)

PARAMETER		TEST CONDITIONS	MIN	TYP ⁽¹⁾	MAX	UNIT
t_{PHL}	Propagation delay time, high- to low-level output	See Figure 6-2	4	8	12	ns
t_{PLH}	Propagation delay time, low- to high-level output		4	8	12	ns
t_t	Transition time (t_r or t_f)	See Figure 6-2		5	10	ns
t_{PZH}	Output-enable time to high level	See Figure 6-3		10	20	ns
t_{PZL}	Output-enable time to low level	See #none#		10	20	ns
t_{PHZ}	Output-disable time from high level	See Figure 6-3		10	20	ns
t_{PLZ}	Output-disable time from low level	See #none#		10	20	ns
$t_{sk(p)}$	Pulse skew	See Figure 6-2 ⁽²⁾ ⁽³⁾		0.5	1.5	ns
$t_{sk(o)}$	Skew limit (pin to pin)				1.5	ns
$t_{sk(lim)}$	Skew limit (device to device)				3	ns
$f_{(max)}$	Maximum operating frequency	See Figure 6-2		32		MHz

(1) All typical values are at $V_{CC} = 3.3V$, $T_A = 25^\circ C$.

(2) Pulse skew is defined as the $|t_{PLH} - t_{PHL}|$ of each channel of the same device.

(3) Skew limit (device to device) is the maximum difference in propagation delay times between any two channels of any two devices.

5.7 Typical Characteristics

Figure 5-1 and Figure 5-2 show typical I_{CC} values at various frequencies/data rates for various termination conditions.

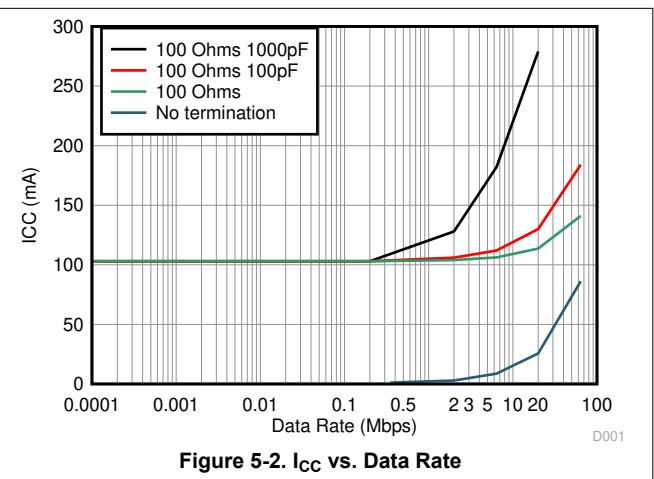
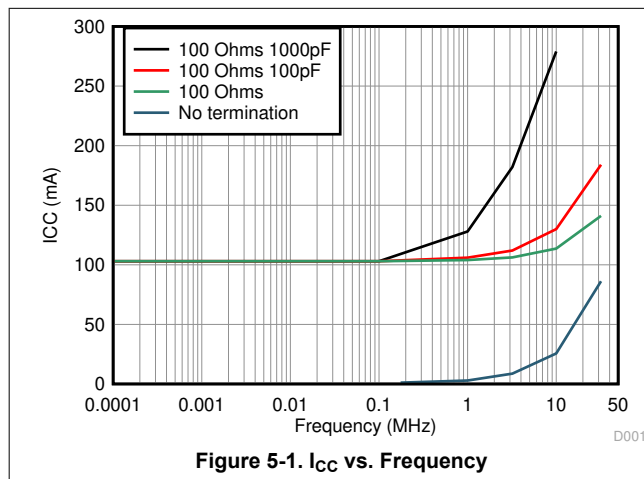

6 Parameter Measurement Information

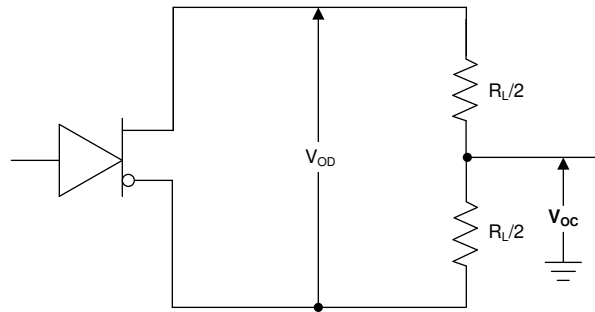
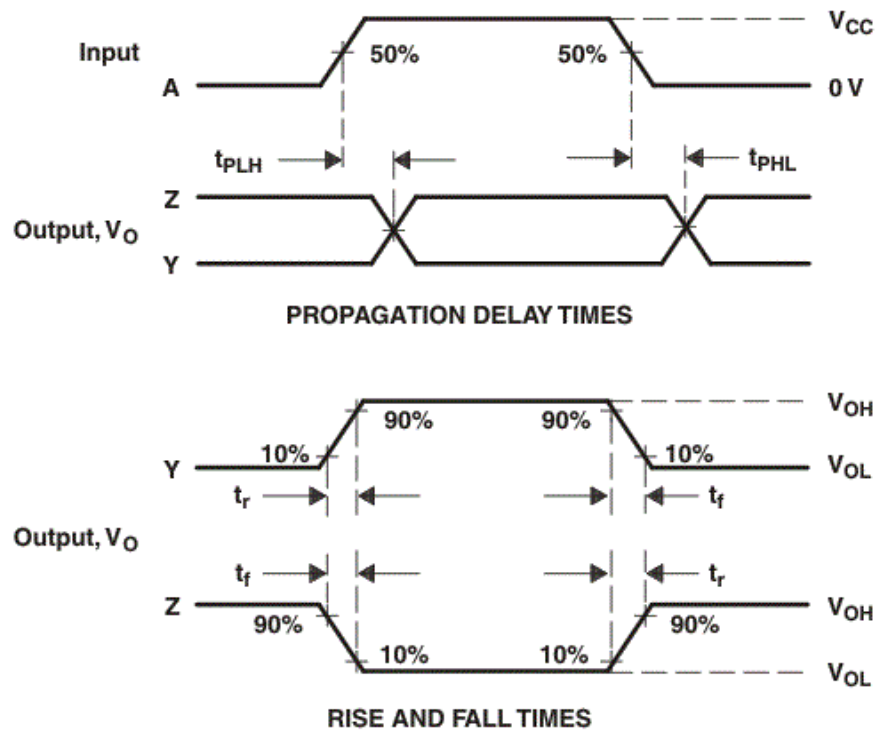
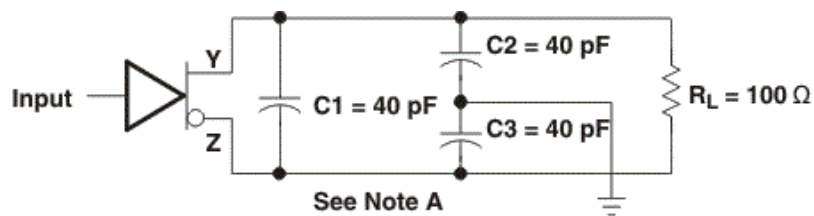
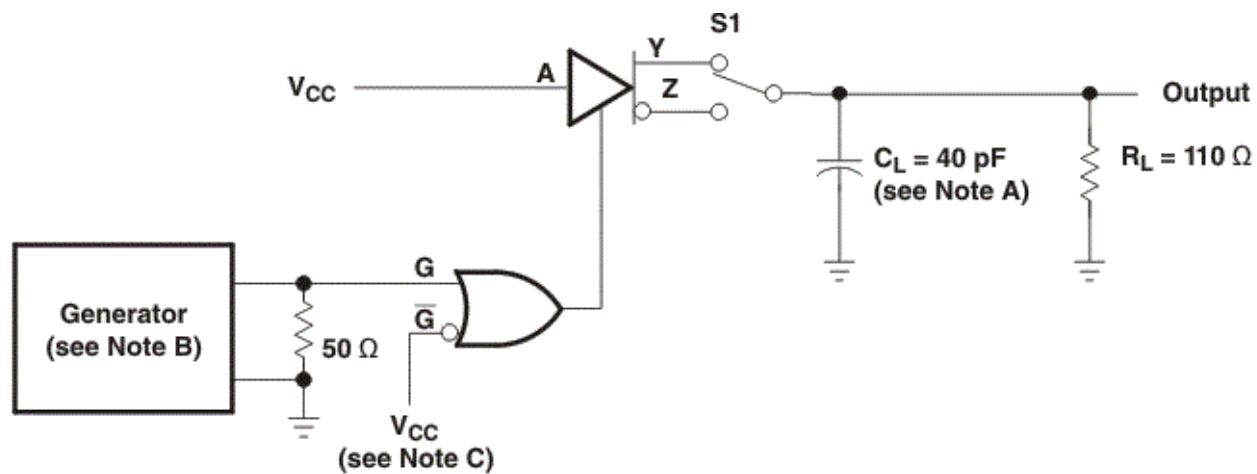

Figure 6-1. Test Circuit, V_{OB} and V_{OC}



- A. C_L includes probe and stray capacitance.
- B. The input pulse is supplied by a generator having the following characteristics: PRR = 10MHz, 50% duty cycle, t_r and $t_f \leq 10$ ns.

Figure 6-2. Test Circuit and Voltage Waveforms, t_{pHL} and t_{pLH}



TEST CIRCUIT

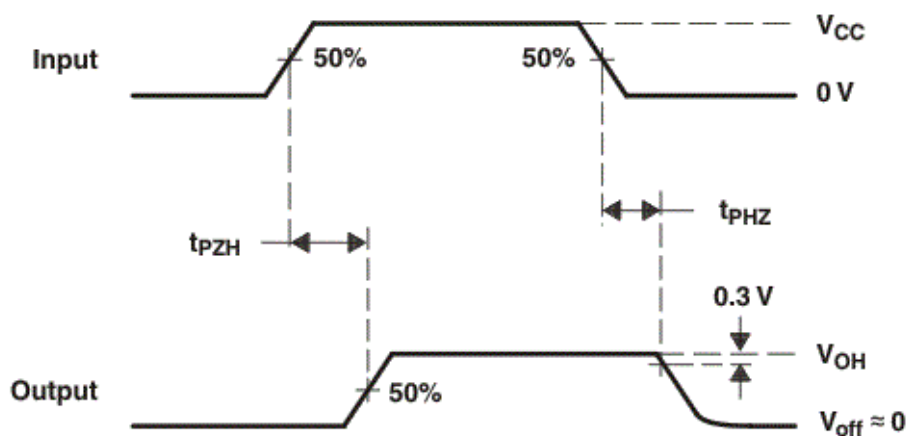

VOLTAGE WAVEFORMS

- A. C_L includes probe and stray capacitance.
- B. The input pulse is supplied by a generator having the following characteristics: PRR = 1MHz, 50% duty cycle, t_r and $t_f \leq 2$ ns.
- C. To test the active-low enable \overline{G} ground G and apply inverted waveform to \overline{G} .

Figure 6-3. Test Circuit and Voltage Waveforms, t_{pZH} and t_{pHZ}

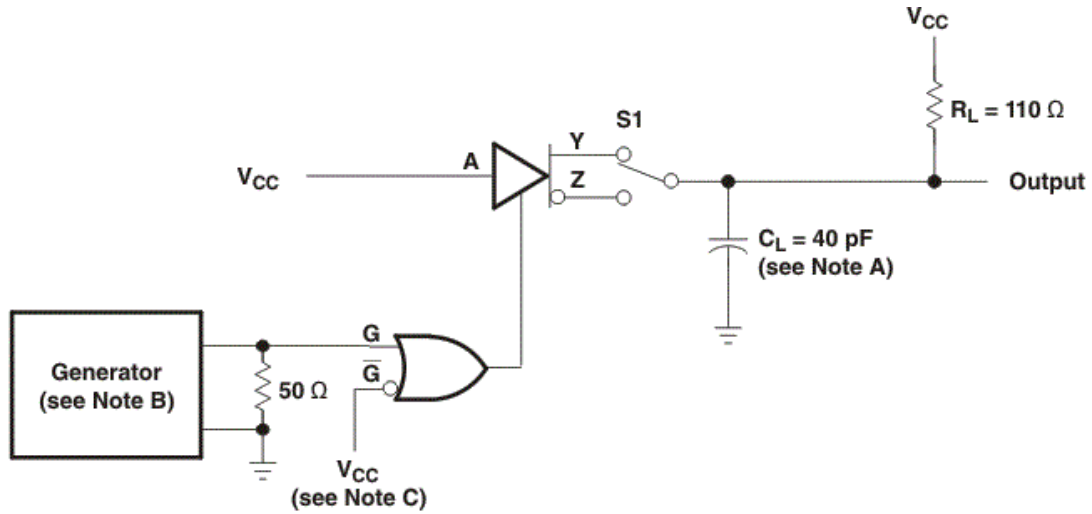

TEST CIRCUIT

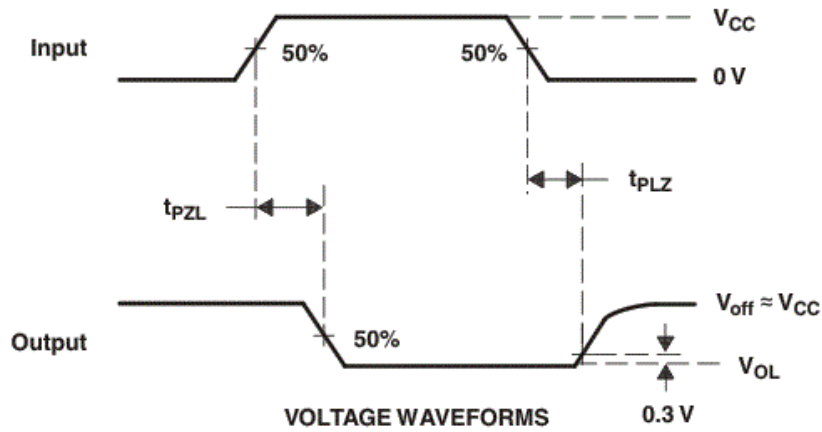

VOLTAGE WAVEFORMS

- A. C_L includes probe and stray capacitance.
- B. The input pulse is supplied by a generator having the following characteristics: PRR = 1MHz, 50% duty cycle, t_r and $t_f \leq 2\text{ns}$.
- C. To test the active-low enable \bar{G} ground G and apply inverted waveform to \bar{G} .

7 Detailed Description

7.1 Overview

The AM26LV31E is a quadruple differential line driver with 3-state outputs. The device is designed to meet TIA/EIA-422-B and ITU Recommendation V.11 drivers with reduced supply voltage. The high current capability of the outputs allow for driving balanced lines, such as twisted-pair transmission lines, and provide a high impedance in the power-off condition. The AM26LV31E is optimized for balanced-bus transmission line at switching rates up to 32MHz.

From a single 3.3V power supply, the device operates four 3-state differential line drivers with integrated active high and active low enables for precise control. The device is capable of accepting 5V logic inputs with a 3.3V supply. The driver is designed to handle loads of a minimum of $\pm 30\text{mA}$ of sink or source current.

7.2 Functional Block Diagram

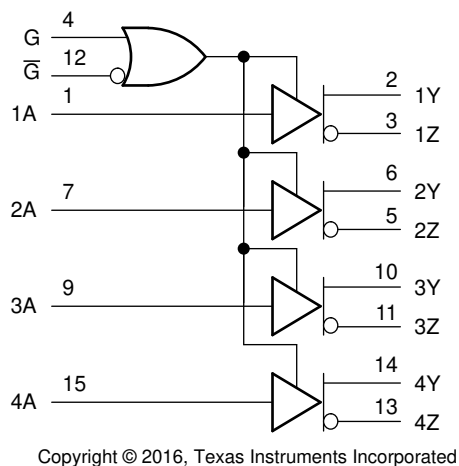

Figure 7-1. Logic Diagram

7.3 Feature Description

7.3.1 Complementary Out-Enable Inputs

The AM26LV31E transmitter outputs can be configured using the G and \bar{G} logic inputs. The transmitter outputs are enabled when either G is set to logic HIGH or \bar{G} is set to logic LOW. The reverse disables the outputs (G = LOW, \bar{G} = HIGH). See [Table 7-1](#) for the complete truth table.

7.3.2 High Output Impedance for Specific Driver Enable Inputs

When the AM26LV31E transmitter outputs are disabled using G and \bar{G} logic inputs, the outputs are set to a high impedance state.

7.4 Device Functional Modes

Table 7-1 lists the functional modes of the AM26LV31E.

Table 7-1. Function Table

INPUT A ⁽¹⁾	ENABLES		OUTPUTS	
	G	\bar{G}	Y	Z
H	H	X	H	L
L	H	X	L	H
H	X	L	H	L
L	X	L	L	H
X	L	H	Z	Z

(1) H = high level, L = low level, X = irrelevant, Z = high impedance (off)

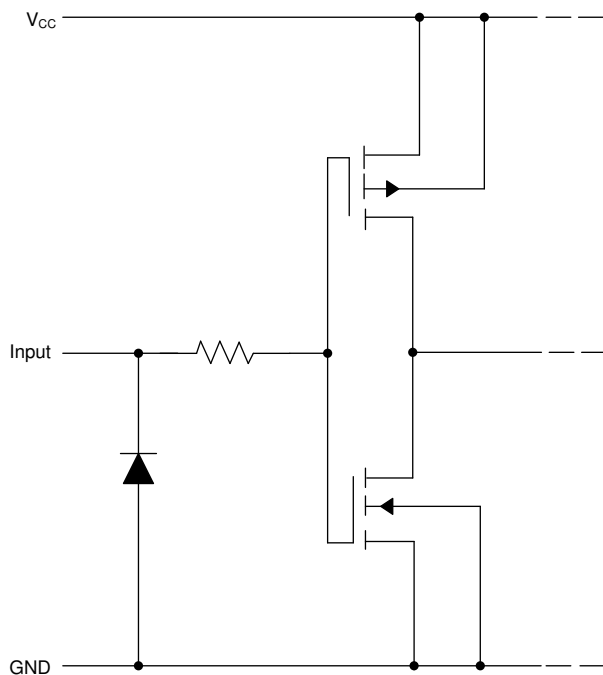

Figure 7-2. Equivalent of Each Input (A, G, or \bar{G}) Schematic

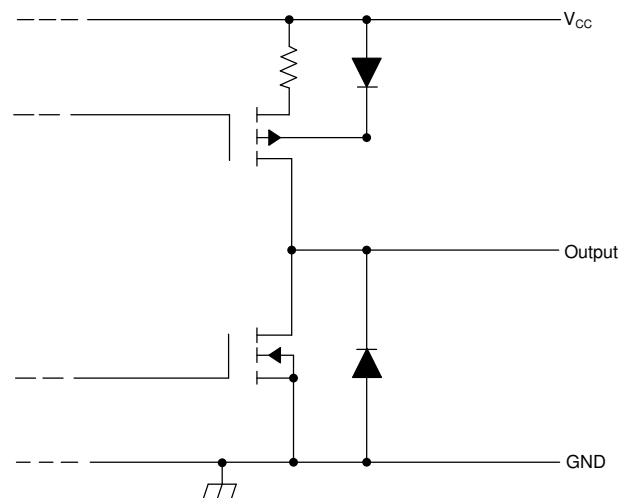

Figure 7-3. Typical of Each Driver Output Schematic

8 Application and Implementation

Note

Information in the following applications sections is not part of the TI component specification, and TI does not warrant its accuracy or completeness. TI's customers are responsible for determining suitability of components for their purposes, as well as validating and testing their design implementation to confirm system functionality.

8.1 Application Information

When designing a system that uses drivers, receivers, and transceivers that comply with RS-422 or RS-485, proper cable termination is essential for highly reliable applications with reduced reflections in the transmission line. Because RS-422 allows only one driver on the bus, if termination is used, it is placed only at the end of the cable near the last receiver. In general, RS-485 requires termination at both ends of the cable. Factors to consider when determining the type of termination usually are performance requirements of the application and the ever-present factor, cost. The different types of termination techniques discussed are unterminated lines, parallel termination, AC termination, and multipoint termination. Laboratory waveforms for each termination technique (except multipoint termination) illustrate the usefulness and robustness of RS-422 (and indirectly, RS-485). Similar results can be obtained if 485-compliant devices and termination techniques are used. For laboratory experiments, 100 feet of 100Ω, 24-AWG, twisted-pair cable (Bertek) was used. A single driver and receiver, TI AM26LV31E and AM26LV32E, respectively, were tested at room temperature with a 3.3V supply voltage. To show voltage waveforms related to transmission-line reflections, the first plot shows output waveforms from the driver at the start of the cable (A/B); the second plot shows input waveforms to the receiver at the far end of the cable (Y).

8.2 Typical Application

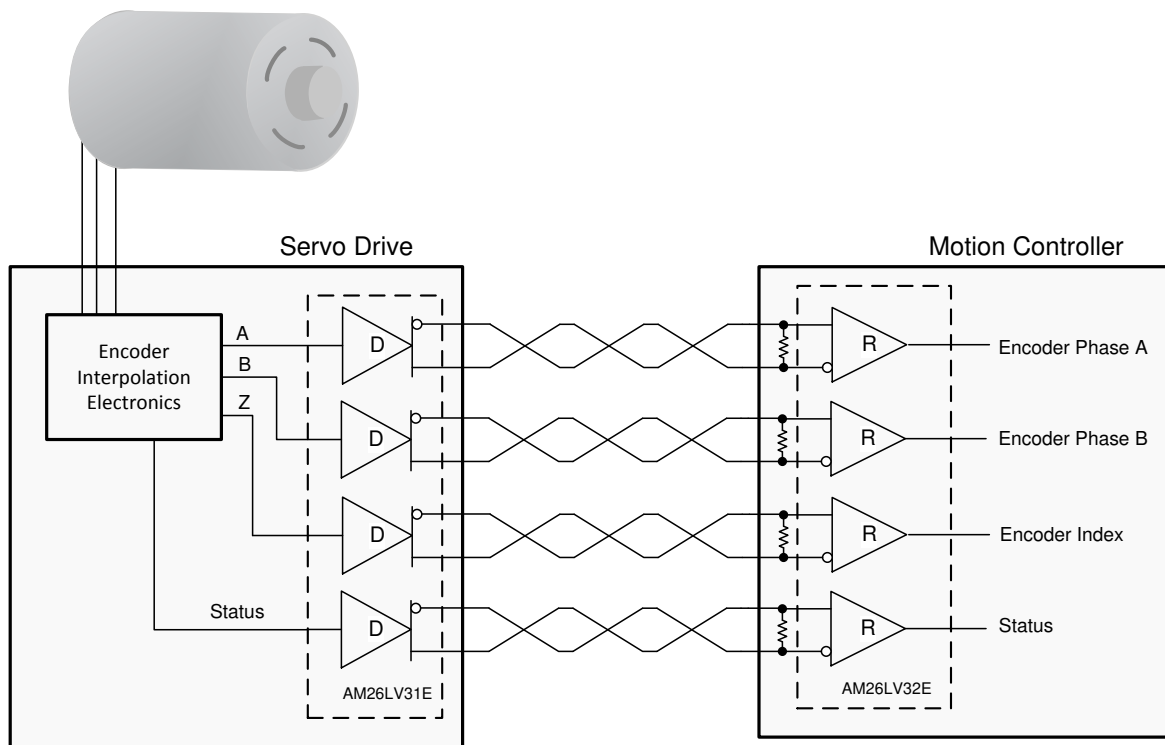

Copyright © 2016, Texas Instruments Incorporated

Figure 8-1. Encoder Application

8.2.1 Design Requirements

This example requires the following:

- 3.3V power source
- RS-485 bus operating at speed compatible with cable length
- Connector that ensures the correct polarity for port pins

8.2.2 Detailed Design Procedure

Place the device close to bus connector to keep traces (stub) short to prevent adding reflections to the bus line. If desired, add external fail-safe biasing to ensure 200mV on the A-B port, if the drive is in high impedance state (see [Fail-safe in RS-485 data buses](#), SLYT080).

8.2.3 Application Curve

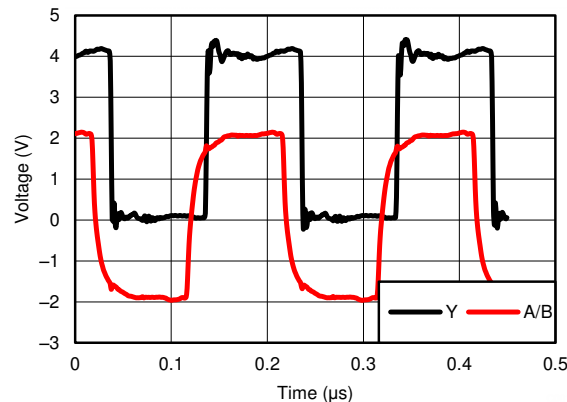

Figure 8-2. Differential 120Ω Terminated Output Waveforms (Cat 5E Cable)

8.3 Power Supply Recommendations

Place 0.1μF bypass capacitors close to the power-supply pins to reduce errors coupling in from noisy or high impedance power supplies.

8.4 Layout

8.4.1 Layout Guidelines

For best operational performance of the device, use good PCB layout practices, including:

- Noise can often propagate into analog circuitry through the power supply of the circuit. Bypass capacitors are used to reduce the coupled noise by providing low impedance power sources local to the analog circuitry.
 - Connect low-ESR, 0.1μF ceramic bypass capacitors between each supply pin and ground, placed as close to the device as possible. A single bypass capacitor from V+ to ground is applicable for single-supply applications.
- Separate grounding for analog and digital portions of circuitry is one of the simplest and most-effective methods of noise suppression. One or more layers on multilayer PCBs are usually devoted to ground planes. A ground plane helps distribute heat and reduces EMI noise pickup. Make sure to physically separate digital and analog grounds, paying attention to the flow of the ground current.
- To reduce parasitic coupling, run the input traces as far away from the supply or output traces as possible. If it is not possible to keep them separate, it is much better to cross the sensitive trace perpendicular as opposed to in parallel with the noisy trace.
- Place the external components as close to the device as possible. Keeping RF and RG close to the inverting input minimizes parasitic capacitance.
- Keep the length of input traces as short as possible. Always remember that the input traces are the most sensitive part of the circuit.

8.4.2 Layout Example

For all Y and Z outputs, make sure the traces are impedance matched to cable used.

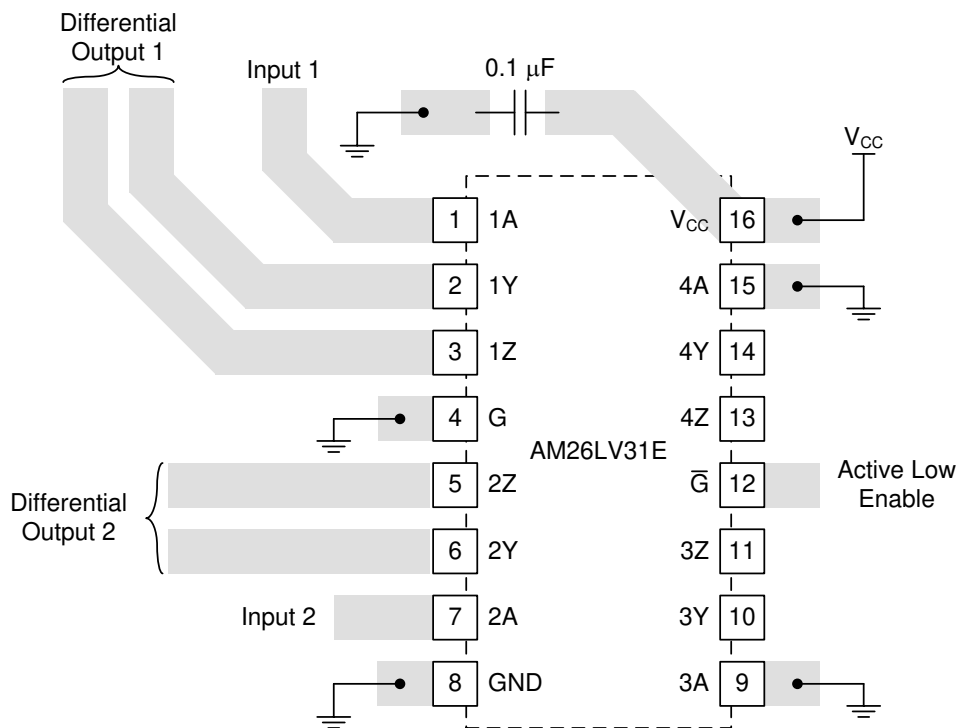

Figure 8-3. Layout Recommendation

9 Device and Documentation Support

9.1 Documentation Support

9.1.1 Related Documentation

For related documentation see the following:

[Failsafe in RS-485 data buses](#), SLYT080

9.2 Receiving Notification of Documentation Updates

To receive notification of documentation updates, navigate to the device product folder on ti.com. In the upper right corner, click on *Alert me* to register and receive a weekly digest of any product information that has changed. For change details, review the revision history included in any revised document.

9.3 Support Resources

[TI E2E™ support forums](#) are an engineer's go-to source for fast, verified answers and design help — straight from the experts. Search existing answers or ask your own question to get the quick design help you need.

Linked content is provided "AS IS" by the respective contributors. They do not constitute TI specifications and do not necessarily reflect TI's views; see TI's [Terms of Use](#).

9.4 Trademarks

TI E2E™ is a trademark of Texas Instruments.

All trademarks are the property of their respective owners.

9.5 Electrostatic Discharge Caution



This integrated circuit can be damaged by ESD. Texas Instruments recommends that all integrated circuits be handled with appropriate precautions. Failure to observe proper handling and installation procedures can cause damage.

ESD damage can range from subtle performance degradation to complete device failure. Precision integrated circuits may be more susceptible to damage because very small parametric changes could cause the device not to meet its published specifications.

9.6 Glossary

[TI Glossary](#) This glossary lists and explains terms, acronyms, and definitions.

10 Revision History

NOTE: Page numbers for previous revisions may differ from page numbers in the current version.

Changes from Revision B (September 2016) to Revision C (April 2024)	Page
• Changed the Device Information table to the <i>Package Information</i> table.....	1
• Changed the <i>Thermal Information</i> table.....	5
• Changed the note in Figure 6-3	7

Changes from Revision A (May 2008) to Revision B (September 2016)	Page
• Added <i>Applications</i> section, <i>Thermal Information</i> table, <i>Feature Description</i> section, <i>Device Functional Modes</i> , <i>Application and Implementation</i> section, <i>Power Supply Recommendations</i> section, <i>Layout</i> section, <i>Device and Documentation Support</i> section, and <i>Mechanical, Packaging, and Orderable Information</i> section	1
• Deleted <i>Ordering Information</i> table, see <i>Mechanical, Packaging, and Orderable Information</i> at the end of the datasheet.....	1
• Changed <i>ESD PROTECTION</i> to <i>ESD Ratings</i> table.....	4
• Changed R _{θJA} for PW package from 108°C/W: to 99.5°C/W.....	5
• Changed R _{θJA} for NS package from 64°C/W: to 74.5°C/W.....	5

-
- Changed $R_{\theta JA}$ for RGY package from 39°C/W: to 39.3°C/W..... 5
-

11 Mechanical, Packaging, and Orderable Information

The following pages include mechanical, packaging, and orderable information. This information is the most current data available for the designated devices. This data is subject to change without notice and revision of this document. For browser-based versions of this data sheet, refer to the left-hand navigation.

PACKAGING INFORMATION

Orderable Device	Status (1)	Package Type	Package Drawing	Pins	Package Qty	Eco Plan (2)	Lead finish/ Ball material (6)	MSL Peak Temp (3)	Op Temp (°C)	Device Marking (4/5)	Samples
AM26LV31EIDR	ACTIVE	SOIC	D	16	2500	RoHS & Green	NIPDAU	Level-1-260C-UNLIM	-40 to 85	AM26LV31EI	Samples
AM26LV31EIDRG4	ACTIVE	SOIC	D	16	2500	RoHS & Green	NIPDAU	Level-1-260C-UNLIM	-40 to 85	AM26LV31EI	Samples
AM26LV31EINSR	ACTIVE	SO	NS	16	2000	RoHS & Green	NIPDAU	Level-1-260C-UNLIM	-40 to 85	26LV31EI	Samples
AM26LV31EIPWR	ACTIVE	TSSOP	PW	16	2000	RoHS & Green	NIPDAU	Level-1-260C-UNLIM	-40 to 85	SB31	Samples
AM26LV31EIPWRG4	ACTIVE	TSSOP	PW	16	2000	RoHS & Green	NIPDAU	Level-1-260C-UNLIM	-40 to 85	SB31	Samples
AM26LV31EIRGYR	ACTIVE	VQFN	RGY	16	3000	RoHS & Green	NIPDAU	Level-2-260C-1 YEAR	-40 to 85	SB31	Samples
AM26LV31EIRGYRG4	ACTIVE	VQFN	RGY	16	3000	RoHS & Green	NIPDAU	Level-2-260C-1 YEAR	-40 to 85	SB31	Samples

(1) The marketing status values are defined as follows:

ACTIVE: Product device recommended for new designs.

LIFEBUY: TI has announced that the device will be discontinued, and a lifetime-buy period is in effect.

NRND: Not recommended for new designs. Device is in production to support existing customers, but TI does not recommend using this part in a new design.

PREVIEW: Device has been announced but is not in production. Samples may or may not be available.

OBSOLETE: TI has discontinued the production of the device.

(2) **RoHS:** TI defines "RoHS" to mean semiconductor products that are compliant with the current EU RoHS requirements for all 10 RoHS substances, including the requirement that RoHS substance do not exceed 0.1% by weight in homogeneous materials. Where designed to be soldered at high temperatures, "RoHS" products are suitable for use in specified lead-free processes. TI may reference these types of products as "Pb-Free".

RoHS Exempt: TI defines "RoHS Exempt" to mean products that contain lead but are compliant with EU RoHS pursuant to a specific EU RoHS exemption.

Green: TI defines "Green" to mean the content of Chlorine (Cl) and Bromine (Br) based flame retardants meet JS709B low halogen requirements of <=1000ppm threshold. Antimony trioxide based flame retardants must also meet the <=1000ppm threshold requirement.

(3) MSL, Peak Temp. - The Moisture Sensitivity Level rating according to the JEDEC industry standard classifications, and peak solder temperature.

(4) There may be additional marking, which relates to the logo, the lot trace code information, or the environmental category on the device.

(5) Multiple Device Markings will be inside parentheses. Only one Device Marking contained in parentheses and separated by a "~" will appear on a device. If a line is indented then it is a continuation of the previous line and the two combined represent the entire Device Marking for that device.

(6) Lead finish/Ball material - Orderable Devices may have multiple material finish options. Finish options are separated by a vertical ruled line. Lead finish/Ball material values may wrap to two lines if the finish value exceeds the maximum column width.

Important Information and Disclaimer:The information provided on this page represents TI's knowledge and belief as of the date that it is provided. TI bases its knowledge and belief on information provided by third parties, and makes no representation or warranty as to the accuracy of such information. Efforts are underway to better integrate information from third parties. TI has taken and continues to take reasonable steps to provide representative and accurate information but may not have conducted destructive testing or chemical analysis on incoming materials and chemicals. TI and TI suppliers consider certain information to be proprietary, and thus CAS numbers and other limited information may not be available for release.

In no event shall TI's liability arising out of such information exceed the total purchase price of the TI part(s) at issue in this document sold by TI to Customer on an annual basis.

OTHER QUALIFIED VERSIONS OF AM26LV31E :

- Enhanced Product : [AM26LV31E-EP](#)

NOTE: Qualified Version Definitions:

- Enhanced Product - Supports Defense, Aerospace and Medical Applications

TAPE AND REEL INFORMATION

QUADRANT ASSIGNMENTS FOR PIN 1 ORIENTATION IN TAPE

*All dimensions are nominal

Device	Package Type	Package Drawing	Pins	SPQ	Reel Diameter (mm)	Reel Width W1 (mm)	A0 (mm)	B0 (mm)	K0 (mm)	P1 (mm)	W (mm)	Pin1 Quadrant
AM26LV31EIDR	SOIC	D	16	2500	330.0	16.4	6.5	10.3	2.1	8.0	16.0	Q1
AM26LV31EINSR	SO	NS	16	2000	330.0	16.4	8.2	10.5	2.5	12.0	16.0	Q1
AM26LV31EIPWR	TSSOP	PW	16	2000	330.0	12.4	6.9	5.6	1.6	8.0	12.0	Q1
AM26LV31EIRGYR	VQFN	RGY	16	3000	330.0	12.4	3.8	4.3	1.5	8.0	12.0	Q1

TAPE AND REEL BOX DIMENSIONS

*All dimensions are nominal

Device	Package Type	Package Drawing	Pins	SPQ	Length (mm)	Width (mm)	Height (mm)
AM26LV31EIDR	SOIC	D	16	2500	356.0	356.0	35.0
AM26LV31EINSR	SO	NS	16	2000	367.0	367.0	38.0
AM26LV31EIPWR	TSSOP	PW	16	2000	367.0	367.0	35.0
AM26LV31EIRGYR	VQFN	RGY	16	3000	367.0	367.0	35.0



PACKAGE OUTLINE

NS0016A

SOP - 2.00 mm max height

SOP



4220735/A 12/2021

NOTES:

1. All linear dimensions are in millimeters. Dimensions in parenthesis are for reference only. Dimensioning and tolerancing per ASME Y14.5M.
2. This drawing is subject to change without notice.
3. This dimension does not include mold flash, protrusions, or gate burrs. Mold flash, protrusions, or gate burrs shall not exceed 0.15 mm, per side.
4. This dimension does not include interlead flash. Interlead flash shall not exceed 0.25 mm, per side.

EXAMPLE BOARD LAYOUT

NS0016A

SOP - 2.00 mm max height

SOP



4220735/A 12/2021

NOTES: (continued)

5. Publication IPC-7351 may have alternate designs.

6. Solder mask tolerances between and around signal pads can vary based on board fabrication site.

EXAMPLE STENCIL DESIGN

NS0016A

SOP - 2.00 mm max height

SOP



SOLDER PASTE EXAMPLE
BASED ON 0.125 mm THICK STENCIL
SCALE:7X

4220735/A 12/2021

NOTES: (continued)

7. Laser cutting apertures with trapezoidal walls and rounded corners may offer better paste release. IPC-7525 may have alternate design recommendations.
8. Board assembly site may have different recommendations for stencil design.

D (R-PDSO-G16)

PLASTIC SMALL OUTLINE



- NOTES:
- A. All linear dimensions are in inches (millimeters).
 - B. This drawing is subject to change without notice.
 - C. Body length does not include mold flash, protrusions, or gate burrs. Mold flash, protrusions, or gate burrs shall not exceed 0.006 (0,15) each side.
 - D. Body width does not include interlead flash. Interlead flash shall not exceed 0.017 (0,43) each side.
 - E. Reference JEDEC MS-012 variation AC.



4220204/A 02/2017

NOTES:

1. All linear dimensions are in millimeters. Any dimensions in parenthesis are for reference only. Dimensioning and tolerancing per ASME Y14.5M.
2. This drawing is subject to change without notice.
3. This dimension does not include mold flash, protrusions, or gate burrs. Mold flash, protrusions, or gate burrs shall not exceed 0.15 mm per side.
4. This dimension does not include interlead flash. Interlead flash shall not exceed 0.25 mm per side.
5. Reference JEDEC registration MO-153.

EXAMPLE BOARD LAYOUT

PW0016A

TSSOP - 1.2 mm max height

SMALL OUTLINE PACKAGE



LAND PATTERN EXAMPLE
EXPOSED METAL SHOWN
SCALE: 10X



4220204/A 02/2017

NOTES: (continued)

- 6. Publication IPC-7351 may have alternate designs.
- 7. Solder mask tolerances between and around signal pads can vary based on board fabrication site.

EXAMPLE STENCIL DESIGN

PW0016A

TSSOP - 1.2 mm max height

SMALL OUTLINE PACKAGE



SOLDER PASTE EXAMPLE
BASED ON 0.125 mm THICK STENCIL
SCALE: 10X

4220204/A 02/2017

NOTES: (continued)

8. Laser cutting apertures with trapezoidal walls and rounded corners may offer better paste release. IPC-7525 may have alternate design recommendations.
9. Board assembly site may have different recommendations for stencil design.

MECHANICAL DATA

NS (R-PDSO-G**)

PLASTIC SMALL-OUTLINE PACKAGE

14-PINS SHOWN



- NOTES:
- A. All linear dimensions are in millimeters.
 - B. This drawing is subject to change without notice.
 - C. Body dimensions do not include mold flash or protrusion, not to exceed 0,15.

RGY (R-PVQFN-N16)

PLASTIC QUAD FLATPACK NO-LEAD

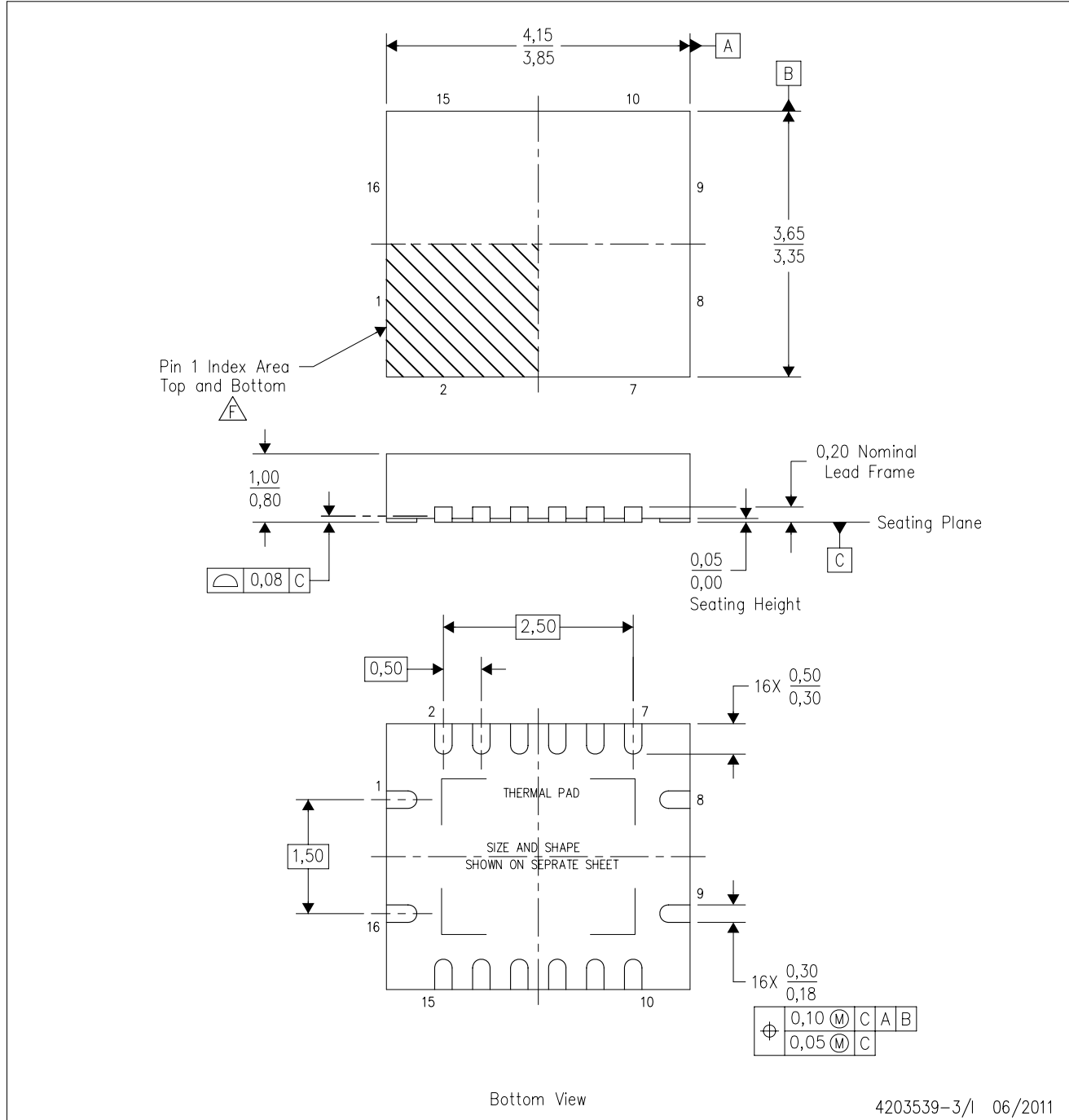

- NOTES:
- A. All linear dimensions are in millimeters. Dimensioning and tolerancing per ASME Y14.5M-1994.
 - B. This drawing is subject to change without notice.
 - C. QFN (Quad Flatpack No-Lead) package configuration.
 - D. The package thermal pad must be soldered to the board for thermal and mechanical performance.
 - E. See the additional figure in the Product Data Sheet for details regarding the exposed thermal pad features and dimensions.
 - F. Pin 1 identifiers are located on both top and bottom of the package and within the zone indicated. The Pin 1 identifiers are either a molded, marked, or metal feature.
 - G. Package complies to JEDEC MO-241 variation BA.

RGY (R-PVQFN-N16)

PLASTIC QUAD FLATPACK NO-LEAD

THERMAL INFORMATION

This package incorporates an exposed thermal pad that is designed to be attached directly to an external heatsink. The thermal pad must be soldered directly to the printed circuit board (PCB). After soldering, the PCB can be used as a heatsink. In addition, through the use of thermal vias, the thermal pad can be attached directly to the appropriate copper plane shown in the electrical schematic for the device, or alternatively, can be attached to a special heatsink structure designed into the PCB. This design optimizes the heat transfer from the integrated circuit (IC).

For information on the Quad Flatpack No-Lead (QFN) package and its advantages, refer to Application Report, QFN/SON PCB Attachment, Texas Instruments Literature No. SLUA271. This document is available at www.ti.com.

The exposed thermal pad dimensions for this package are shown in the following illustration.

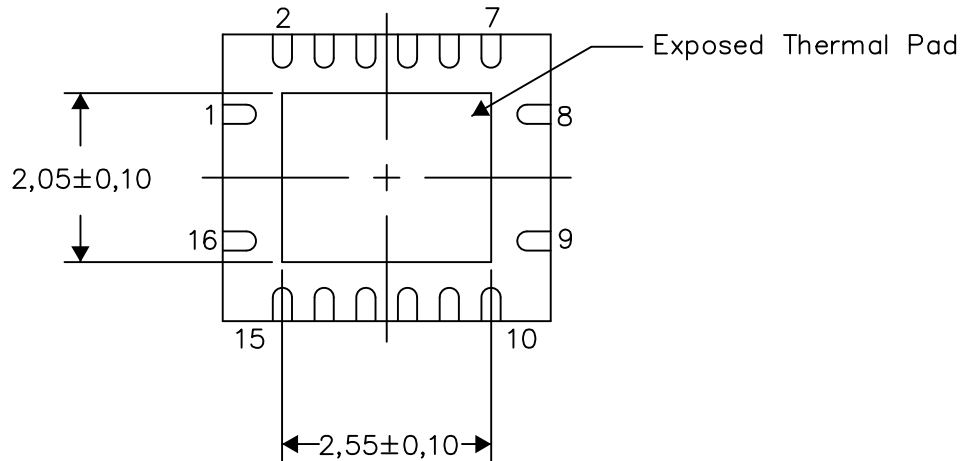

Bottom View

Exposed Thermal Pad Dimensions

4206353-3/P 03/14

NOTE: All linear dimensions are in millimeters

RGY (R-PVQFN-N16)

PLASTIC QUAD FLATPACK NO-LEAD

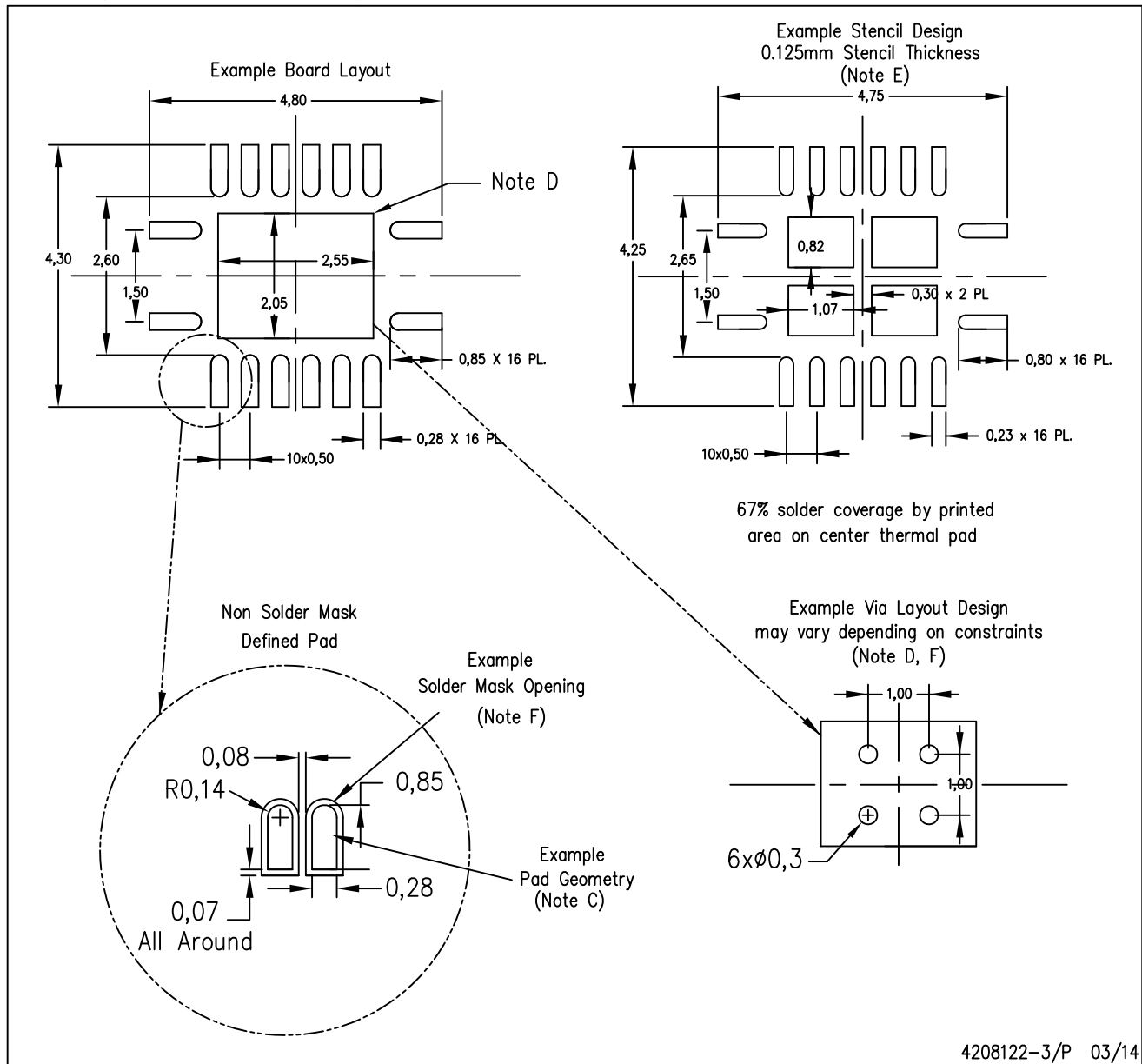

4208122-3/P 03/14

- NOTES:
- A. All linear dimensions are in millimeters.
 - B. This drawing is subject to change without notice.
 - C. Publication IPC-7351 is recommended for alternate designs.
 - D. This package is designed to be soldered to a thermal pad on the board. Refer to Application Note, Quad Flat-Pack QFN/SON PCB Attachment, Texas Instruments Literature No. SLUA271, and also the Product Data Sheets for specific thermal information, via requirements, and recommended board layout. These documents are available at www.ti.com <<http://www.ti.com>>.
 - E. Laser cutting apertures with trapezoidal walls and also rounding corners will offer better paste release. Customers should contact their board assembly site for stencil design recommendations. Refer to IPC 7525 for stencil design considerations.
 - F. Customers should contact their board fabrication site for minimum solder mask web tolerances between signal pads.

IMPORTANT NOTICE AND DISCLAIMER

TI PROVIDES TECHNICAL AND RELIABILITY DATA (INCLUDING DATA SHEETS), DESIGN RESOURCES (INCLUDING REFERENCE DESIGNS), APPLICATION OR OTHER DESIGN ADVICE, WEB TOOLS, SAFETY INFORMATION, AND OTHER RESOURCES "AS IS" AND WITH ALL FAULTS, AND DISCLAIMS ALL WARRANTIES, EXPRESS AND IMPLIED, INCLUDING WITHOUT LIMITATION ANY IMPLIED WARRANTIES OF MERCHANTABILITY, FITNESS FOR A PARTICULAR PURPOSE OR NON-INFRINGEMENT OF THIRD PARTY INTELLECTUAL PROPERTY RIGHTS.

These resources are intended for skilled developers designing with TI products. You are solely responsible for (1) selecting the appropriate TI products for your application, (2) designing, validating and testing your application, and (3) ensuring your application meets applicable standards, and any other safety, security, regulatory or other requirements.

These resources are subject to change without notice. TI grants you permission to use these resources only for development of an application that uses the TI products described in the resource. Other reproduction and display of these resources is prohibited. No license is granted to any other TI intellectual property right or to any third party intellectual property right. TI disclaims responsibility for, and you will fully indemnify TI and its representatives against, any claims, damages, costs, losses, and liabilities arising out of your use of these resources.

TI's products are provided subject to [TI's Terms of Sale](#) or other applicable terms available either on [ti.com](https://www.ti.com) or provided in conjunction with such TI products. TI's provision of these resources does not expand or otherwise alter TI's applicable warranties or warranty disclaimers for TI products.

TI objects to and rejects any additional or different terms you may have proposed.

Mailing Address: Texas Instruments, Post Office Box 655303, Dallas, Texas 75265
Copyright © 2024, Texas Instruments Incorporated

Looking for pricing, stock, or lifecycle information?

Click below to explore more details on WIN SOURCE:

 [View AM26LV31EIDRG4 on WIN SOURCE](#)

 [Texas Instruments](#) Information

Optimize Your Supply Chain with WIN SOURCE Solutions

-  Global Sourcing Solution
-  Obsolete Management
-  Cost Control Management
-  Shortage Management
-  Alternative Solution
-  Excess Inventory Management