



**THE DATASHEET OF
CSD95373AQ5M**



CSD95373AQ5M Synchronous Buck NexFET™ Power Stage

1 Features

- 45 A Continuous Operating Current Capability
- 92.6% System Efficiency at 25 A
- Ultra-Low Power Loss of 2.6 W at 25 A
- High Frequency Operation (up to 2 MHz)
- High Density – SON 5 × 6-mm Footprint
- Ultra-Low Inductance Package
- System Optimized PCB Footprint
- 3.3 V and 5 V PWM Signal Compatible
- Diode Emulation Mode with FCCM
- Analog Temperature Output
- Tri-State PWM Input
- Integrated Bootstrap Switch
- Optimized Dead Time for Shoot Through Protection
- RoHS Compliant – Lead-Free Terminal Plating
- Halogen Free

2 Applications

- Multiphase Synchronous Buck Converter
 - High Frequency Applications
 - High-Current, Low Duty Cycle Applications
- Point of Load Dc-Dc Converters
- Memory and Graphic Cards
- Desktop and Server VR11.x and VR12.x for VCore Synchronous Buck Converters

3 Description

The CSD95373AQ5M NexFET™ Power Stage is a highly-optimized design for use in a high-power, high-density Synchronous Buck converters. This product integrates the driver IC and NexFET technology to complete the power stage switching function. The driver IC has a built-in selectable diode emulation function that enables DCM operation to improve light load efficiency. This combination produces high current, high efficiency, and high speed switching capability in a small 5 × 6 mm outline package. It also integrates the temperature sensing functionality to simplify system design and improve accuracy. In addition, the PCB footprint has been optimized to help reduce design time and simplify the completion of the overall system design.

Device Information⁽¹⁾

Device	Media	Qty	Package	Ship
CSD95373AQ5M	13-Inch Reel	2500	SON 5-mm × 6-mm Package	Tape and Reel
CSD95373AQ5MT	7-Inch Reel	250		

(1) For all available packages, see the orderable addendum at the end of the data sheet.

Application Diagram

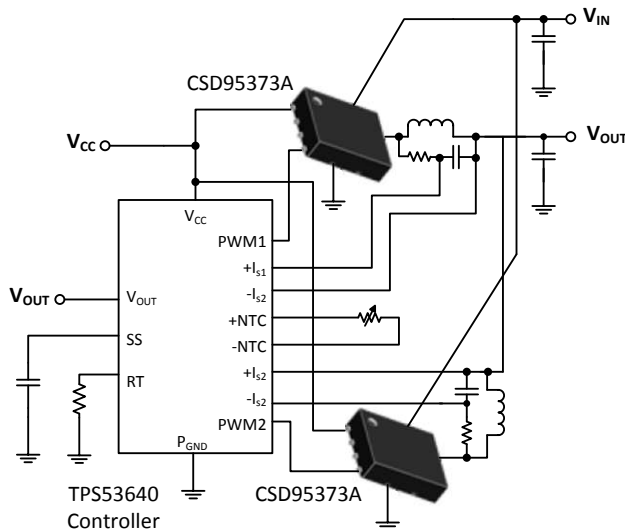

Typical Power Stage Efficiency and Power Loss

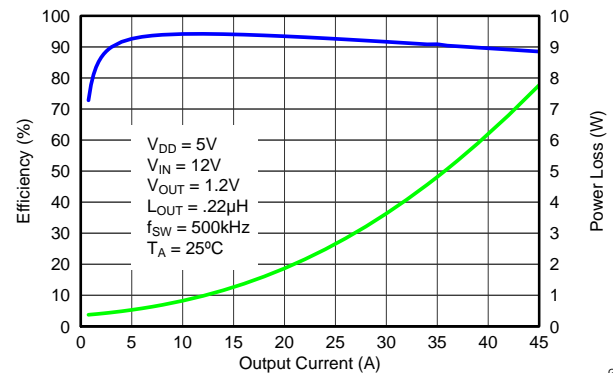

G001



Table of Contents

1 Features	1	7.2 Feature Description.....	9
2 Applications	1	8 Application and Implementation	14
3 Description	1	8.1 Application Information.....	14
4 Revision History	2	9 Layout	16
5 Pin Configuration And Functions	3	9.1 Layout Guidelines	16
6 Specifications	4	10 Application Schematic	18
6.1 Absolute Maximum Ratings	4	11 Device and Documentation Support	19
6.2 Handling Ratings.....	4	11.1 Trademarks	19
6.3 Recommended Operating Conditions.....	4	11.2 Electrostatic Discharge Caution.....	19
6.4 Thermal Information	4	11.3 Glossary	19
6.5 Electrical Characteristics.....	5	12 Mechanical, Packaging, and Orderable Information	20
6.6 Typical Power Stage Device Characteristics	7	12.1 Mechanical Drawing.....	20
7 Detailed Description	9	12.2 Recommended PCB Land Pattern.....	21
7.1 Functional Block Diagram	9	12.3 Recommended Stencil Opening	21

4 Revision History

Changes from Original (December 2013) to Revision A

Page

• Added 7" inch reel information	1
• TAO voltage increased to 3.3 V	3
• Capacitor changed from X6R to X7R	3
• Increased V_{IN} from 14.5 V to 16 V	4
• Added table note for max input voltage	4
• Added conditions to typical characteristic curves.	7

5 Pin Configuration And Functions

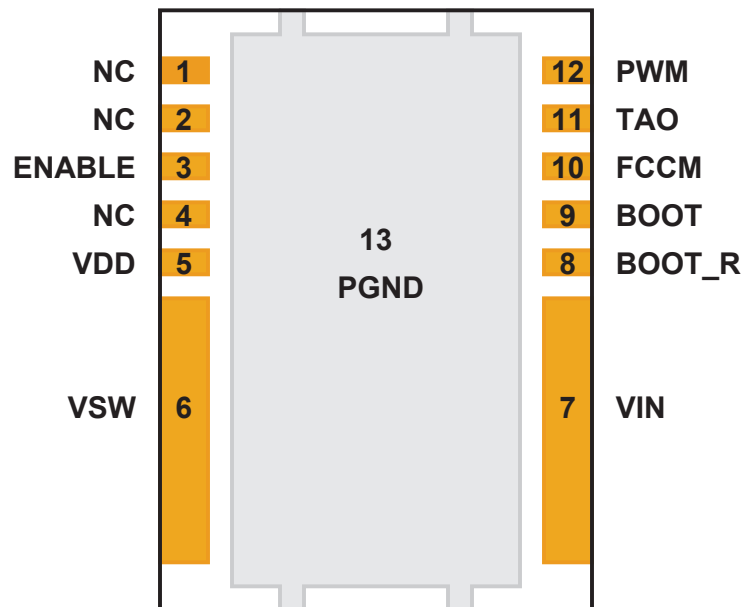

PIN DESCRIPTION

PIN		DESCRIPTION
NO.	NAME	
1, 2, 4	NC	No Connect, must leave floating
3	ENABLE	Enables device operation. If ENABLE = logic HIGH, turns on device. If ENABLE = logic LOW, the device is turned off and both MOSFET gates are actively pulled low. An internal 100 k Ω pulldown resistor pulls the ENABLE pin LOW if left floating.
5	V _{DD}	Supply Voltage to Gate Driver and internal circuitry
6	V _{SW}	Phase node connecting the HS MOSFET Source and LS MOSFET Drain - pin connection to the output inductor
7	V _{IN}	Input Voltage Pin. Connect input capacitors close to this pin.
8	BOOT_R	Return path for HS gate driver, connected to V _{SW} internally
9	BOOT	Bootstrap capacitor connection. Connect a minimum of 0.1 μ F 16 V X7R, ceramic capacitor from BOOT to BOOT_R pins. The bootstrap capacitor provides the charge to turn on the Control FET. The bootstrap diode is integrated.
10	FCCM	This pin enables the Diode Emulation function. When this pin is held LOW, Diode Emulation Mode is enabled for Sync FET. When FCCM is HIGH, the device operated in Forced Continuous Conduction Mode. An internal 5 μ A current source will pull the FCCM pin to V _{DD} if left floating.
11	TAO/ FAULT	Temperature amplifier output. Reports a voltage proportional to the die temperature. An ORing diode is integrated in the IC. When used in multiphase application, a single wire can be used to connect the TAO pins of all the ICs. Only the highest temperature is reported. TAO is pulled up to 3.3 V if Thermal Shutdown occurs. TAO should be bypassed to P _{GND} with a 1 nF 16 V X7R ceramic capacitor.
12	PWM	Pulse width modulated tri-state input from external controller. Logic LOW sets Control FET gate low and Sync FET gate high. Logic HIGH sets Control FET gate high and Sync FET gate low. Open or High Z sets both MOSFET gates low if greater than the tri-State Shutdown Hold-off Time (t _{3HT})
13	P _{GND}	Power Ground

6 Specifications

6.1 Absolute Maximum Ratings⁽¹⁾

 $T_A = 25^\circ\text{C}$ (unless otherwise noted)

	VALUE		UNIT
	MIN	MAX	
V_{IN} to P_{GND}	-0.3	25	V
V_{IN} to V_{SW}	-0.3	25	V
V_{IN} to V_{SW} (<10 ns)	-7	27	V
V_{SW} to P_{GND}	-0.3	20	V
V_{SW} to P_{GND} (<10 ns)	-7	23	V
V_{DD} to P_{GND}	-0.3	7	V
ENABLE, PWM, FCCM, TAO to P_{GND} ⁽²⁾	-0.3	$V_{DD} + 0.3$	V
BOOT to BOOT_R ⁽²⁾	-0.3	$V_{DD} + 0.3$	V
Power Dissipation, P_D		12	W
Operating Temperature Range, T_J	-55	150	$^\circ\text{C}$

- (1) Stresses above those listed in "Absolute Maximum Ratings" may cause permanent damage to the device. These are stress ratings only and functional operation of the device at these or any other conditions beyond those indicated under "Recommended Operating Conditions" is not implied. Exposure to Absolute Maximum rated conditions for extended periods may affect device reliability.
- (2) Should not exceed 7 V.

6.2 Handling Ratings

			MIN	MAX	UNIT
T_{stg}	Storage Temperature Range		-55	150	$^\circ\text{C}$
$V_{(ESD)}$	Electrostatic discharge	Human Body Model (HBM)	-2000	2000	V
		Charged Device Model (CDM)	-500	500	

6.3 Recommended Operating Conditions

 $T_A = 25^\circ$ (unless otherwise noted)

			MIN	MAX	UNIT
Gate Drive Voltage, V_{DD}			4.5	5.5	V
Input Supply Voltage, V_{IN} ⁽¹⁾				16	V
Output Voltage, V_{OUT}				5.5	V
Continuous Output Current, I_{OUT}	$V_{IN} = 12\text{ V}$, $V_{DD} = 5\text{ V}$, $V_{OUT} = 1.8\text{ V}$, $f_{SW} = 500\text{ kHz}$, $L_{OUT} = 0.22\text{ }\mu\text{H}$ ⁽²⁾			45	A
Peak Output Current, I_{OUT-PK} ⁽³⁾				67	A
Switching Frequency, f_{SW}	$C_{BST} = 0.1\text{ }\mu\text{F}$ (min)			2000	kHz
On Time Duty Cycle	$f_{SW} = 1\text{ MHz}$			85%	
Minimum PWM On Time			20		ns
Operating Temperature			-40	125	$^\circ\text{C}$

- (1) Operating at high V_{IN} can create excessive AC voltage overshoots on the switch node (V_{SW}) during MOSFET switching transients. For reliable operation, the switch node (V_{SW}) to ground voltage must remain at or below the *Absolute Maximum Ratings*.
- (2) Measurement made with six 10- μF (TDK C3216X5R1C106KT or equivalent) ceramic capacitors placed across V_{IN} to P_{GND} pins.
- (3) System conditions as defined in Note 1. Peak Output Current is applied for $t_p = 50\text{ }\mu\text{s}$.

6.4 Thermal Information

 $T_A = 25^\circ\text{C}$ (unless otherwise noted)

THERMAL METRIC		MIN	TYP	MAX	UNIT
$R_{\theta JC}$	Junction-to-Case Thermal Resistance (Top of package) ⁽¹⁾			15	$^\circ\text{C/W}$
$R_{\theta JB}$	Junction-to-Board Thermal Resistance ⁽²⁾			2	

- (1) $R_{\theta JC}$ is determined with the device mounted on a 1-inch² (6.45-cm²), 2-oz (.071-mm thick) Cu pad on a 1.5-inches x 1.5-inches, 0.06-inch (1.52-mm) thick FR4 board.
- (2) $R_{\theta JB}$ value based on hottest board temperature within 1 mm of the package.

6.5 Electrical Characteristics

 $T_A = 25^\circ\text{C}$, $V_{DD} = \text{POR to } 5.5\text{ V}$ (unless otherwise noted)

PARAMETER	CONDITIONS	MIN	TYP	MAX	UNIT
P_{Loss}					
Power Loss ⁽¹⁾	$V_{IN} = 12\text{ V}$, $V_{DD} = 5\text{ V}$, $V_{OUT} = 1.2\text{ V}$, $I_{OUT} = 25\text{ A}$, $f_{SW} = 500\text{ kHz}$, $L_{OUT} = 0.22\text{ }\mu\text{H}$, $T_J = 25^\circ\text{C}$		2.6		W
Power Loss ⁽²⁾	$V_{IN} = 12\text{ V}$, $V_{DD} = 5\text{ V}$, $V_{OUT} = 1.2\text{ V}$, $I_{OUT} = 25\text{ A}$, $f_{SW} = 500\text{ kHz}$, $L_{OUT} = 0.22\text{ }\mu\text{H}$, $T_J = 125^\circ\text{C}$		3.3		W
V_{IN}					
V_{IN} Quiescent Current, I_Q	ENABLE = 0, $V_{DD} = 5\text{ V}$			10	μA
V_{DD}					
Standby Supply Current, I_{DD}	ENABLE = 0, PWM = 0			250	μA
Operating Supply Current, I_{DD}	ENABLE = 5 V, PWM = 50% Duty cycle, $f_{SW} = 500\text{ kHz}$		16		mA
POWER-ON RESET AND UNDER VOLTAGE LOCKOUT					
Power-On Reset, V_{DD} Rising		3.6		3.9	V
UVLO, V_{DD} Falling		3.4		3.7	V
Hysteresis		100		250	mV
Startup Delay ⁽³⁾	ENABLE = 5 V		6		μs
ENABLE					
Logic Level High, V_{IH}	Schmitt Trigger Input See Figure 12	2			V
Logic Level Low, V_{IL}			0.8		V
Weak Pulldown Impedance			100		k Ω
Rising Propagation Delay, t_{PDH}			3		μs
Falling Propagation Delay, t_{PDL}			30		ns
FCCM⁽²⁾					
Logic Level High, V_{IH}	Schmitt Trigger Input See Figure 14 and Figure 15	2			V
Logic Level Low, V_{IL}			0.8		V
Weak Pullup Current			5		μA
THERMAL SHUTDOWN⁽²⁾					
Start Threshold		150	165		$^\circ\text{C}$
Temperature Hysteresis			25		$^\circ\text{C}$

(1) Measurement made with six 10- μF (TDK C3216X5R1C106KT or equivalent) ceramic capacitors placed across V_{IN} to P_{GND} pins

(2) Specified by design

(3) POR to V_{SW} Rising

Electrical Characteristics (continued)
 $T_A = 25^\circ\text{C}$, $V_{DD} = \text{POR to } 5.5 \text{ V}$ (unless otherwise noted)

PARAMETER	CONDITIONS	MIN	TYP	MAX	UNIT
PWM					
$I_{P\text{WMH}}$	PWM = 5 V		500		μA
$I_{P\text{WML}}$	PWM = 0		-500		μA
PWM Logic Level High, $V_{P\text{WMH}}$	$C_{P\text{WM}} = 10 \text{ pF}$	2.3	2.5	2.7	V
PWM Logic Level Low, $V_{P\text{WML}}$		0.7	0.9	1.1	V
PWM Tri-State Open Voltage			1.5		V
PWM to V_{SW} Propagation Delay, t_{PDLH} and $t_{\text{PDHL}}^{(2)}$			50		ns
Tri-State Shutdown Hold-off Time, $t_{3\text{HT}}^{(2)}$			30		ns
Tri-State Shutdown Propagation Delay, $t_{3\text{SD}}^{(2)}$			80	160	ns
Tri-State Recovery Propagation Delay, $t_{3\text{RD}}^{(2)}$			50	80	ns
Diode Emulation Minimum On Time, $t_{\text{DEM}}^{(2)}$			150		ns
BOOTSTRAP SWITCH					
Forward Voltage, V_{FBOOT}	Measured from V_{DD} to V_{BOOT} , $I_{\text{F}} = 10 \text{ mA}$		200	360	mV
Reverse Leakage, $I_{\text{RBOOT}}^{(1)}$	$V_{\text{BOOT}} - V_{\text{DD}} = 20 \text{ V}$		0.15	1	μA
ZERO CROSSING COMPARATOR					
LS FET Turn-off Current	Diode Emulation Mode Enabled $V_{\text{OUT}} = 1.8 \text{ V}$, $L = 150 \text{ nH}$	0		1.1	A
THERMAL ANALOG OUTPUT TAO					
Output Voltage at 25°C		0.56	0.60	0.64	V
Output Voltage Temperature Coefficient			8		$\text{mV}/^\circ\text{C}$

6.6 Typical Power Stage Device Characteristics

$T_J = 125^\circ\text{C}$, unless stated otherwise. The Typical CSD95373A System Characteristic curves are based on measurements made on a PCB design with dimensions of 4-inches (W) \times 3.5-inches (L) \times 0.062-inch (T) and 6 copper layers of 1-oz. copper thickness. See the *Application and Implementation* section for detailed explanation.

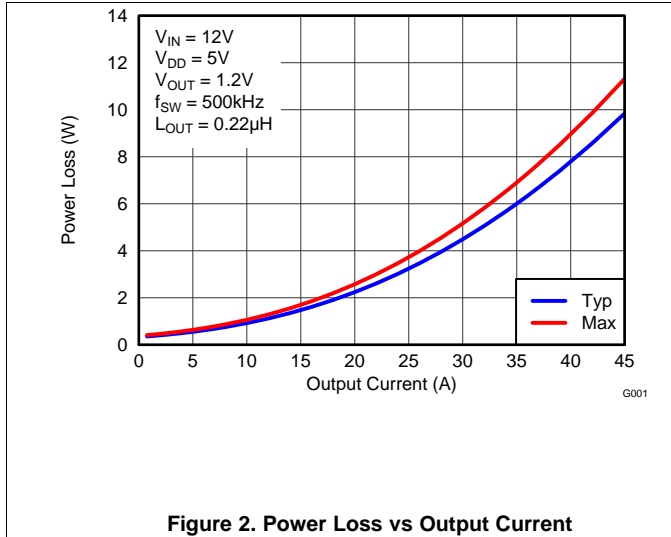

Figure 2. Power Loss vs Output Current

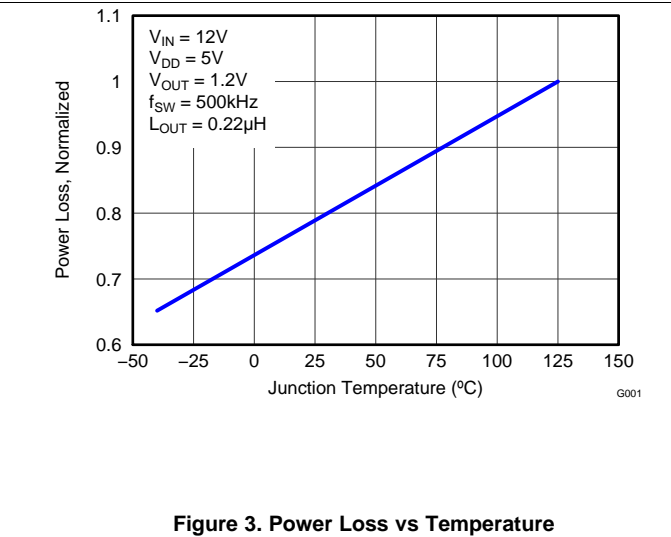

Figure 3. Power Loss vs Temperature

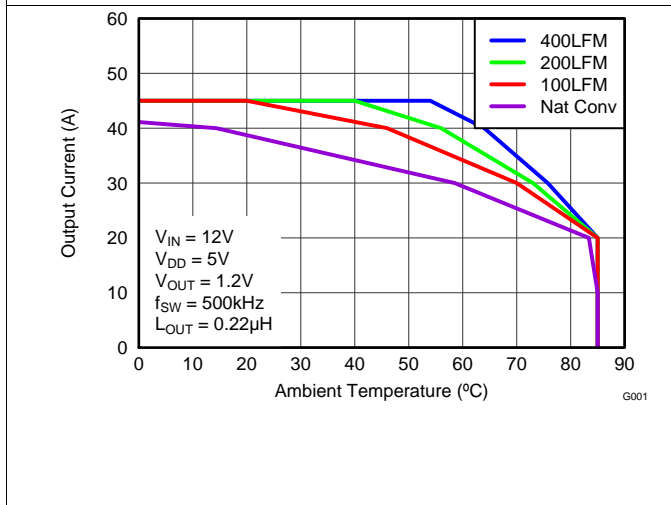

Figure 4. Safe Operating Area (SOA)– PCB Horizontal Mount⁽¹⁾

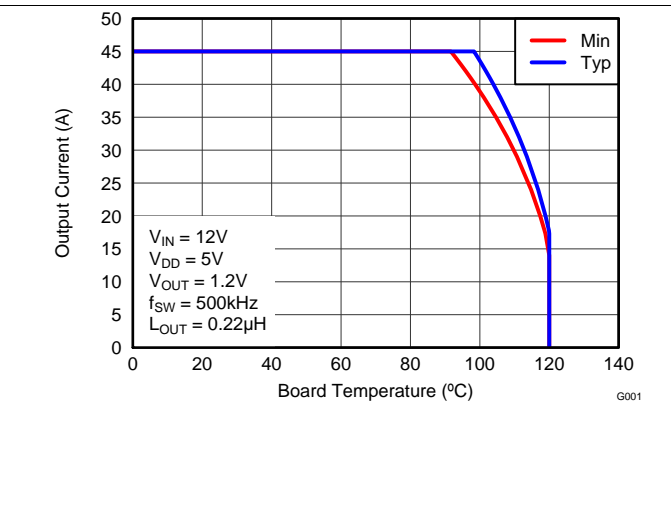

Figure 5. Typical Safe Operating Area (SOA) ⁽¹⁾

Typical Power Stage Device Characteristics (continued)

$T_J = 125^\circ\text{C}$, unless stated otherwise. The Typical CSD95373A System Characteristic curves are based on measurements made on a PCB design with dimensions of 4-inches (W) x 3.5-inches (L) x 0.062-inch (T) and 6 copper layers of 1-oz. copper thickness. See the [Application and Implementation](#) section for detailed explanation.

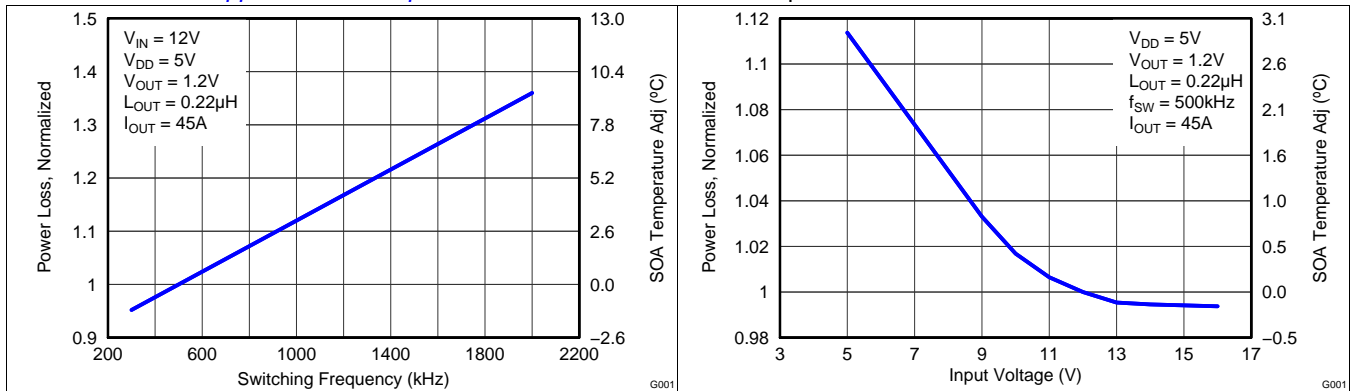

Figure 6. Normalized Power Loss vs Frequency

Figure 7. Normalized Power Loss vs Input Voltage

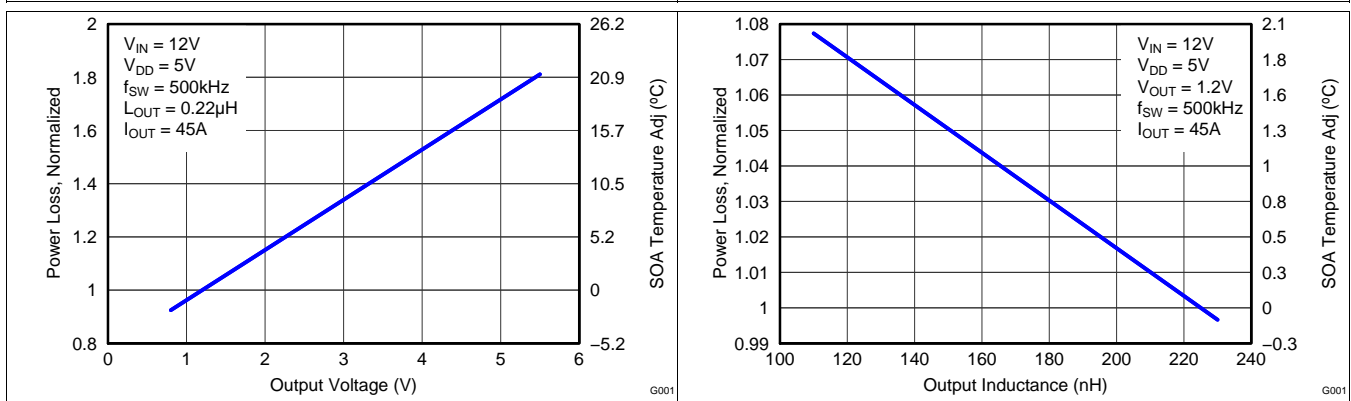

Figure 8. Normalized Power Loss vs Output Voltage

Figure 9. Normalized Power Loss vs Output Inductance

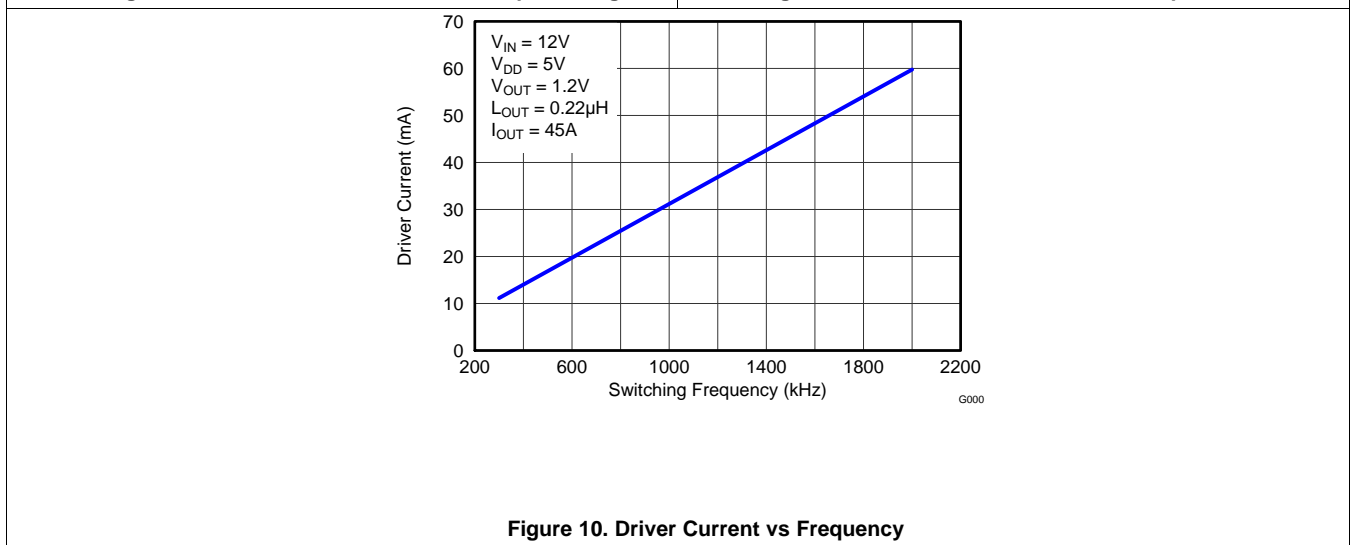
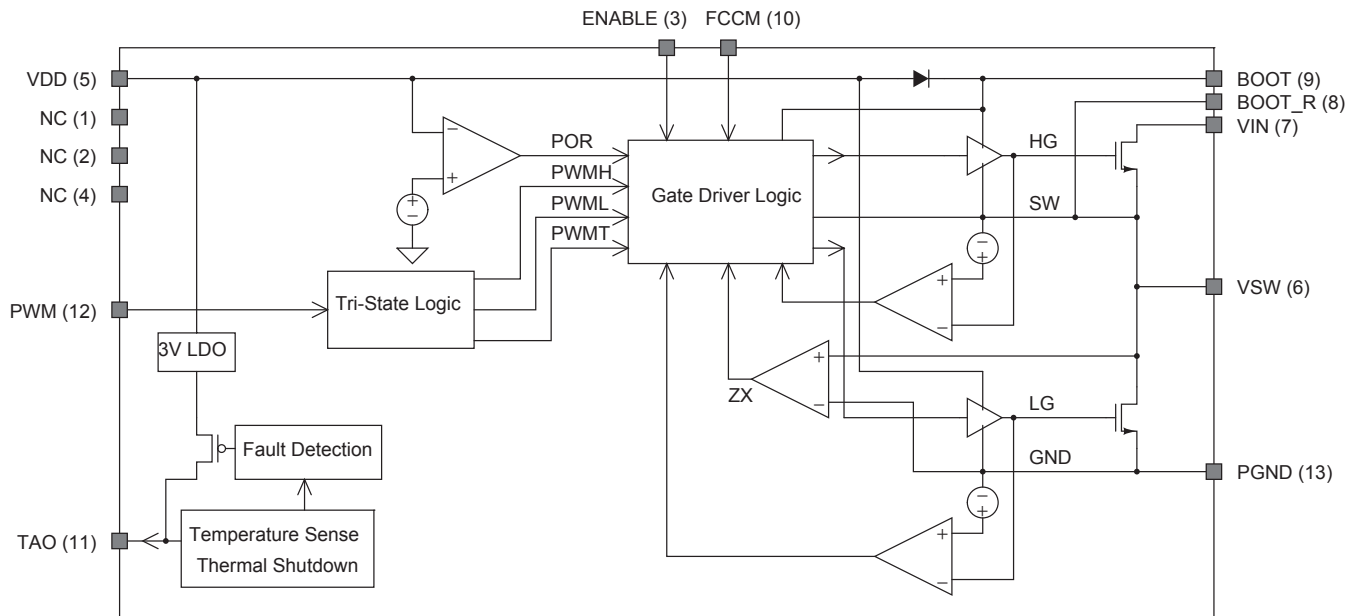

Figure 10. Driver Current vs Frequency

7 Detailed Description

7.1 Functional Block Diagram



7.2 Feature Description

7.2.1 Powering CSD95373AQ5M And Gate Drivers

An external V_{DD} voltage is required to supply the integrated gate driver IC and provide the necessary gate drive power for the MOSFETs. The gate driver IC is capable of supplying in excess of 4 A peak current into the MOSFET gates to achieve fast switching. A 1 μF 10 V X5R or higher ceramic capacitor is recommended to bypass V_{DD} pin to P_{GND} . A bootstrap circuit to provide gate drive power for the Control FET is also included. The bootstrap supply to drive the Control FET is generated by connecting a 100 nF 16 V X5R ceramic capacitor between BOOT and BOOT_R pins. An optional R_{BOOT} resistor can be used to slow down the turn on speed of the Control FET and reduce voltage spikes on the V_{SW} node. A typical 1 to 4.7 Ω value is a compromise between switching loss and V_{SW} spike amplitude.

Feature Description (continued)

7.2.2 Undervoltage Lockout Protection (UVLO)

The V_{DD} supply is monitored for UVLO conditions and both Control FET and Sync FET gates are held low until adequate supply is available. An internal comparator evaluates the V_{DD} voltage level and if V_{DD} is greater than the Power On Reset threshold (V_{POR}), the gate driver becomes active. If V_{DD} is less than the UVLO threshold, the gate driver is disabled and the internal MOSFET gates are actively driven low. At the rising edge of the V_{DD} voltage, both Control FET and Sync FET gates are actively held low during V_{DD} transitions between 1 V to V_{POR} . This region is referred to as the Gate Drive Latch Zone (see Figure 11). In addition, at the falling edge of the V_{DD} voltage, both Control FET and Sync FET gates are actively held low during the UVLO to 1 V transition.

The Power Stage CSD95373AQ5M device must be powered up and enabled before the PWM signal is applied.

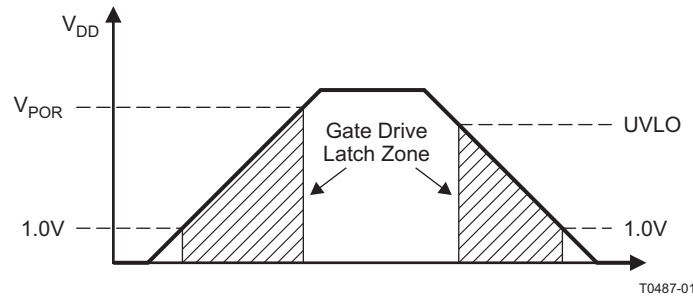

Figure 11. UVLO Operation

7.2.3 Enable

The ENABLE pin is TTL compatible. The logic level thresholds are sustained under all V_{DD} operating conditions between V_{POR} to V_{DD} . In addition, if this pin is left floating, a weak internal pulldown resistor of 100 k Ω pulls the ENABLE pin below the logic level low threshold. The operational functions of this pin should follow the timing diagram outlined in Figure 12. A logic level low actively holds both Control FET and Sync FET gates low and V_{DD} pin should typically draw less than 5 μ A.

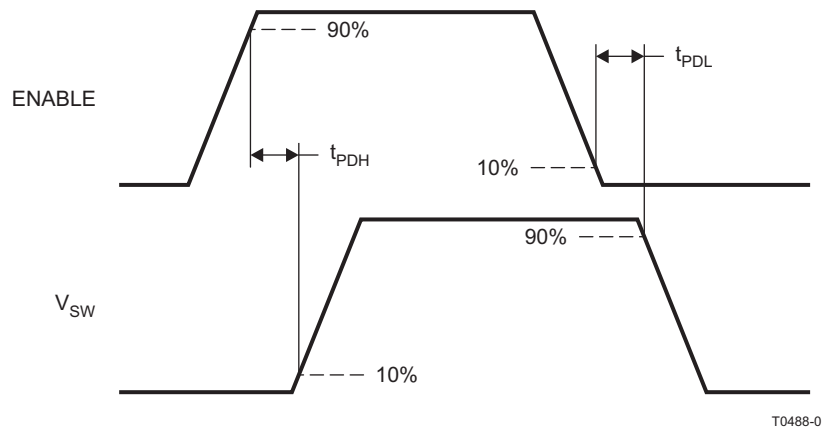

Figure 12. CSD95373AQ5M ENABLE Timing Diagram ($V_{DD} = PWM = 5$ V)

7.2.4 Power-Up Sequencing

If the ENABLE signal is used, it is necessary to ensure proper co-ordination with the ENABLE and soft-start features of the external PWM controller in the system. If the CSD95373AQ5M was disabled through ENABLE without sequencing with the PWM IC controller, the buck converter output will have no voltage or fall below regulation set point voltage. As a result, the PWM controller IC delivers Max duty cycle on the PWM line. If the Power Stage is re-enabled by driving the ENABLE pin high, there will be an extremely large input inrush current when the output voltage builds back up again. The input inrush current might have undesirable consequences such as inductor saturation, driving the input power supply into current limit or even catastrophic failure of the

Feature Description (continued)

CSD95373AQ5M device. Disabling the PWM controller is recommended when the CSD95373AQ5M is disabled. The PWM controller should always be re-enabled by going through soft-start routine to control and minimize the input inrush current and reduce current and voltage stress on all buck converter components. TI recommends that the external PWM controller be disabled when CSD95373AQ5M is disabled or nonoperational because of UVLO.

When ENABLE signal is toggled, there is an internal 3 μ s hold-off time before the driver responds to PWM events to ensure the analog sensing circuitry is properly powered and stable. This hold-off time should be considered when designing the power-up sequencing of the controller IC and the Power Stage.

7.2.5 PWM

The input PWM pin incorporates a tri-state function. The Control FET and Sync FET gates are forced low if the PWM pin is left floating for more than the tri-state Hold off time (t_{3HT}). The tri-state mode can be entered by actively driving the PWM input to the V_{3T} voltage, or the PWM input can be made high impedance and internal current sources drive PWM to V_{3T} . The PWM input can source up to I_{PWMH} and sink down to I_{PWML} current to drive PWM to the V_{3T} voltage, but consumes no current when sitting at the V_{3T} voltage. Operation in and out of tri-state mode should follow the timing diagram outlined in Figure 13. Both V_{PWML} and V_{PWMH} threshold levels are set to accommodate both 3.3 V and 5 V logic controllers. During typical operation, the PWM signal should be driven to logic levels Low and High with a maximum of 500 Ω sink/source impedance respectively.

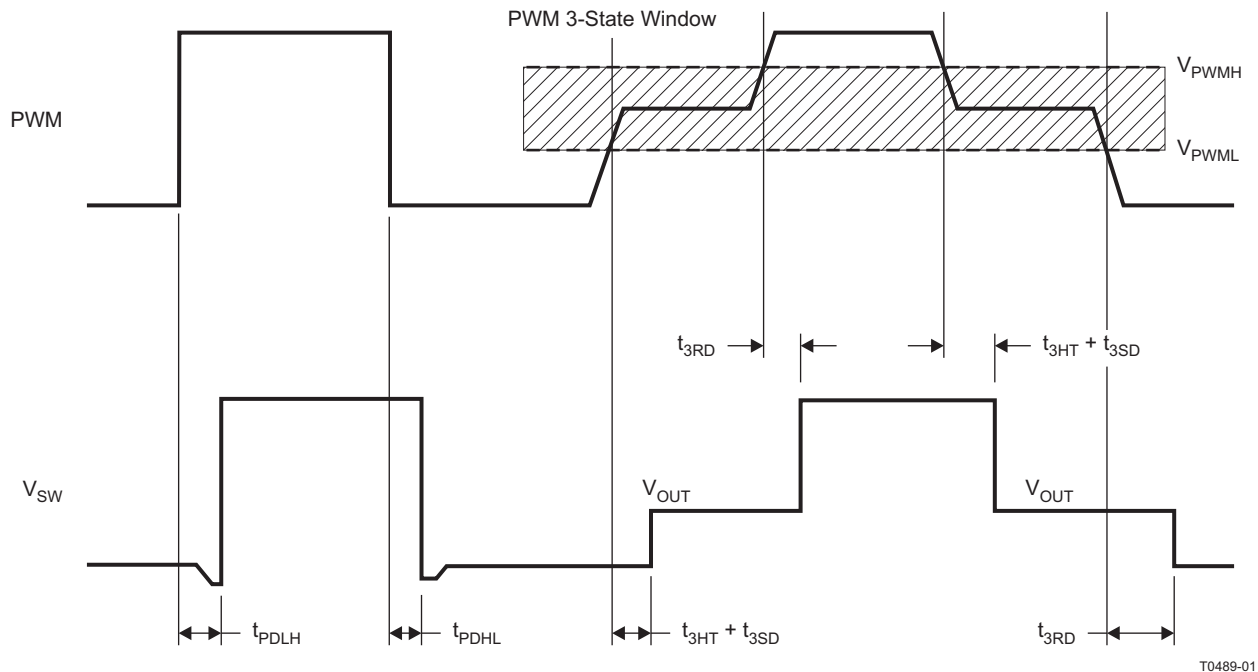

Figure 13. PWM Timing Diagram

7.2.6 FCCM

The input FCCM pin enables the Power Stage device to operate in either continuous current conduction mode or diode emulation mode. When FCCM is driven above its high threshold, the Power Stage operates in continuous conduction mode regardless of the polarity of the output inductor current. When FCCM is driven below its low threshold, the Power Stage's internal zero-cross detection circuit is enabled. When the zero-cross detection circuit is active, diode emulation mode is entered on the third consecutive PWM pulse in which a zero-crossing event is detected. If FCCM is driven high after diode emulation mode has been enabled, continuous conduction mode begins after the next PWM event. See Figure 14 and Figure 15 for FCCM timing

Feature Description (continued)

7.2.7 TAO/Fault (Thermal Analog Output/Protection Flag)

During typical operation, the output TAO pin is a highly accurate analog temperature measurement of the lead-frame temperature of the Power Stage. Because the source junction of the Sync FET sits directly on the lead-frame of the Power Stage, this output can be used as an accurate measurement of the junction temperature of the Sync FET. The TAO pin should be bypassed to P_{GND} using a 1 nF X7R ceramic capacitor to ensure accurate temperature measurement.

This Power Stage device has built-in overtemperature protection (described in [Overtemperature](#)), which is flagged by pulling TAO to 3.3 V. The TAO pin also includes a built in ORing function. When connecting TAO pins of more than one device together, the TAO bus automatically reads the highest TAO voltage among all devices. This greatly simplifies the temperature sense and fault reporting design for multi-phase applications, where a single line TAO/FAULT bus can be used to tie the TAO pins of all phases together and the system can monitor the temperature of the hottest component.

7.2.7.1 Overtemperature

An overtemperature fault occurs when the dies temperature reaches Thermal Shutdown Temperature (see the [Electrical Characteristics](#)). An overtemperature event is the only fault condition to which the Power Stage automatically reacts. When the overtemperature event is detected, the Power Stage automatically turns off both HS and LS MOSFETs and pulls TAO to 3.3 V. If the temperature falls below the overtemperature threshold hysteresis band, the driver again responds to PWM commands and the TAO pin returns to typical operation. A weak pulldown is used to pull TAO back from a fault event, so there is a significant delay before the TAO output reports the correct temperature.

7.2.7.2 Gate Drivers

This Power Stage has an internal high-performance gate driver IC that is trimmed to achieve minimum dead-time for lowest possible switching loss and switch-node ringing reduction. To eliminate the possibility of shoot-through at light load conditions, the dead-time is adjusted to a longer period when the inductor current is negative prior to a PWM HIGH input.

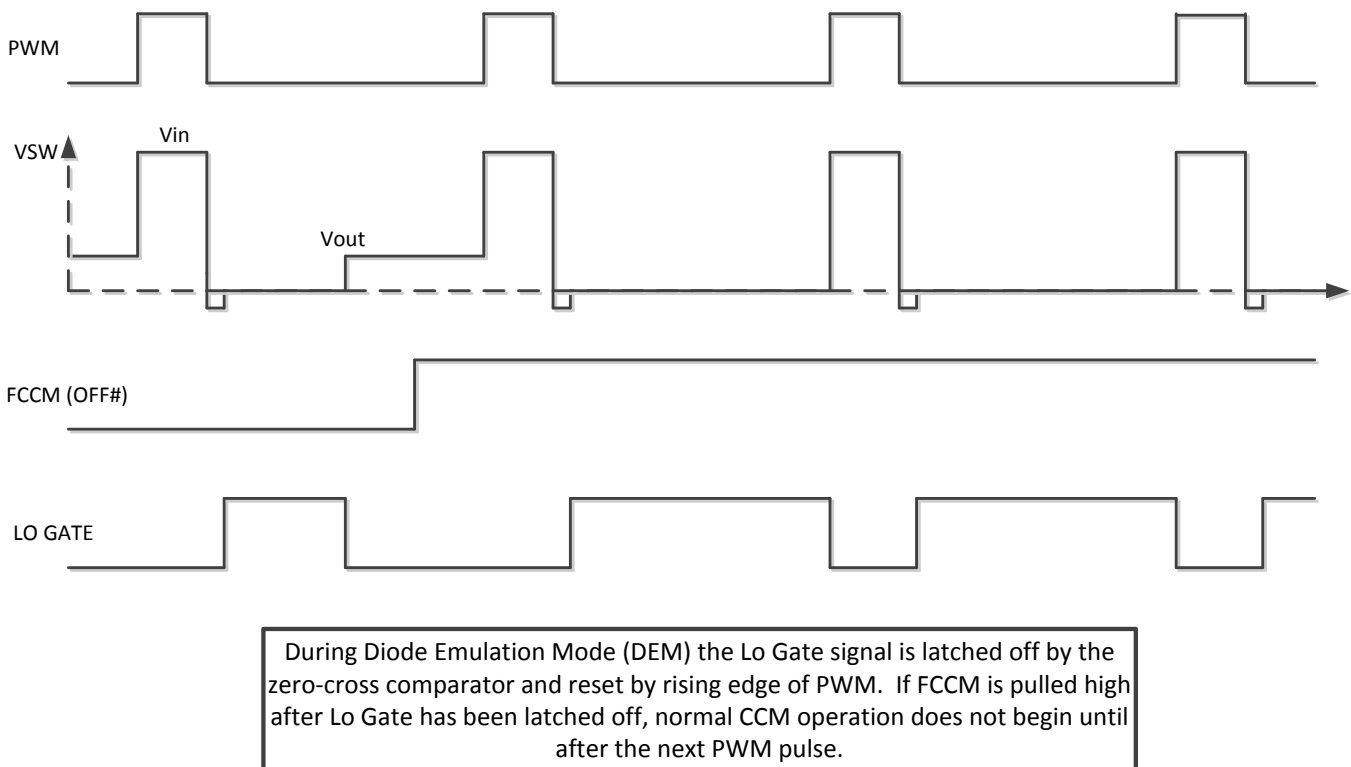
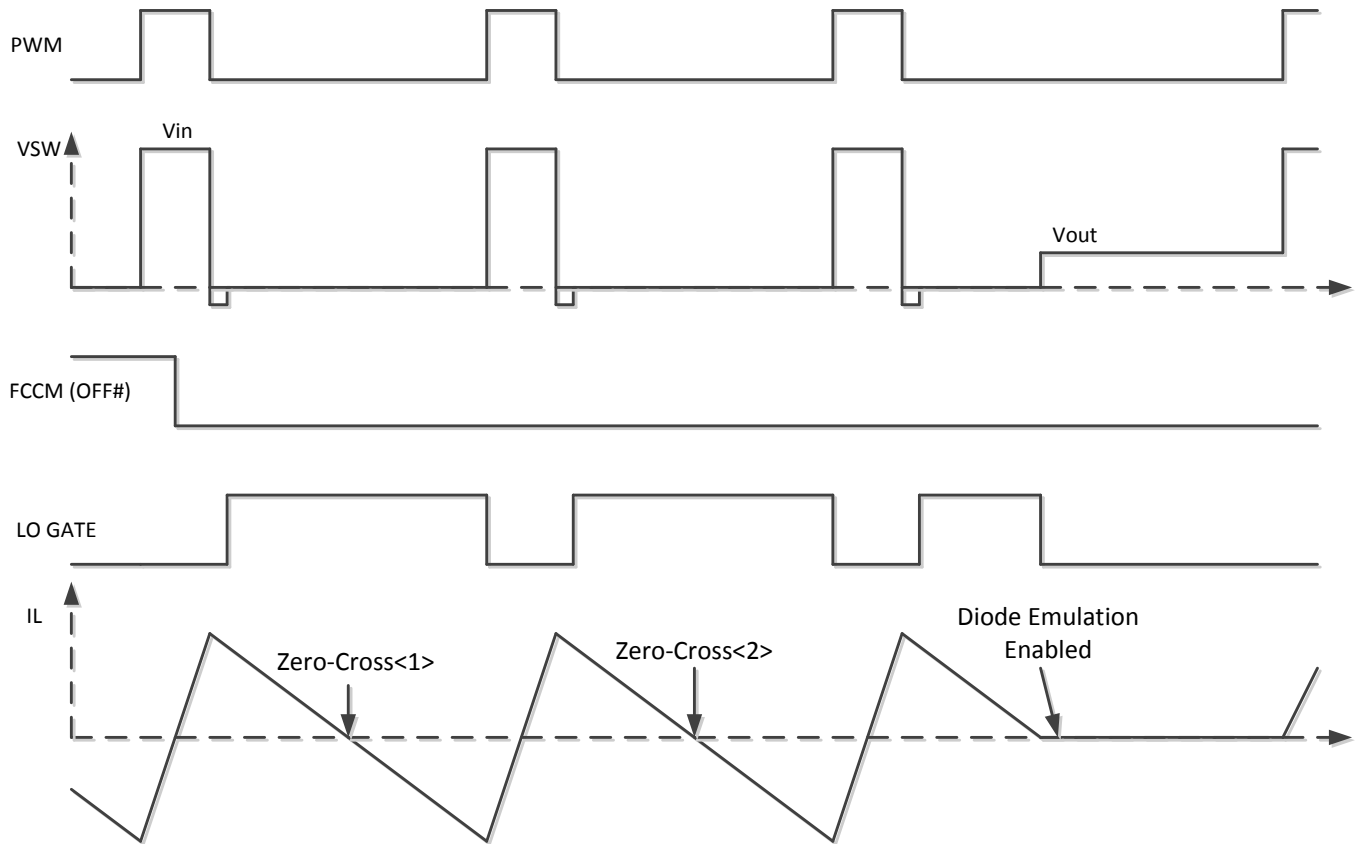

Figure 14. FCCM Rising Timing Diagram

Feature Description (continued)



Zero-cross detection is enabled by FCCM low. Diode-Emulation Mode is entered on the third consecutive PWM pulse in which a zero-crossing event is detected. If at any time no zero-cross event is detected when FCCM is low, the zero-cross counter is reset and diode-emulation mode is not enabled. If FCCM remains low, diode-emulation mode will be re-enabled on the third consecutive PWM pulse in which a zero-cross event is detected.

Figure 15. FCCM Falling Timing Diagram

8 Application and Implementation

8.1 Application Information

The Power Stage CSD95373AQ5M is a highly optimized design for synchronous buck applications using NexFET devices with a 5 V gate drive. The Control FET and Sync FET silicon are parametrically tuned to yield the lowest power loss and highest system efficiency. As a result, a rating method is used that is tailored towards a more systems centric environment. The high-performance gate driver IC integrated in the package helps minimize the parasitics and results in extremely fast switching of the power MOSFETs. System level performance curves such as Power Loss, Safe Operating Area, and normalized graphs allow engineers to predict the product performance in the actual application.

8.1.1 Power Loss Curves

MOSFET centric parameters such as $R_{DS(ON)}$ and Q_{gd} are primarily needed by engineers to estimate the loss generated by the devices. To simplify the design process for engineers, TI has provided measured power loss performance curves. [Figure 2](#) plots the power loss of the CSD95373AQ5M as a function of load current. This curve is measured by configuring and running the CSD95373AQ5M as it would be in the final application. The measured power loss is the CSD95373AQ5M device power loss, which consists of both input conversion loss and gate drive loss. [Equation 1](#) is used to generate the power loss curve.

$$\text{Power Loss} = (V_{IN} \times I_{IN}) + (V_{DD} \times I_{DD}) - (V_{SW_AVG} \times I_{OUT}) \quad (1)$$

The power loss curve in [Figure 2](#) is measured at the maximum recommended junction temperature of $T_J = 125^\circ\text{C}$ under isothermal test conditions.

8.1.2 Safe Operating Curves (SOA)

The SOA curves in the CSD95373AQ5M data sheet give engineers guidance on the temperature boundaries within an operating system by incorporating the thermal resistance and system power loss. [Figure 4](#) and [Figure 5](#) outline the temperature and airflow conditions required for a given load current. The area under the curve dictates the safe operating area. All the curves are based on measurements made on a PCB design with dimensions of 4" (W) \times 3.5" (L) \times 0.062" (T) and 6 copper layers of 1 oz. copper thickness.

8.1.3 Normalized Curves

The normalized curves in the CSD95373AQ5M data sheet give engineers guidance on the Power Loss and SOA adjustments based on their application specific needs. These curves show how the power loss and SOA boundaries adjust for a given set of systems conditions. The primary y-axis is the normalized change in power loss and the secondary y-axis is the change in system temperature required in order to comply with the SOA curve. The change in power loss is a multiplier for the Power Loss curve and the change in temperature is subtracted from the SOA curve.

Application Information (continued)

8.1.4 Calculating Power Loss And SOA

The user can estimate product loss and SOA boundaries by arithmetic means (see the [Design Example](#)). Though the Power Loss and SOA curves in this data sheet are taken for a specific set of test conditions, the following procedure outlines the steps engineers should take to predict product performance for any set of system conditions.

8.1.4.1 Design Example

Operating Conditions: Output Current (I_{OUT}) = 30 A, Input Voltage (V_{IN}) = 7 V, Output Voltage (V_{OUT}) = 1.5 V, Switching Frequency (f_{SW}) = 800 kHz, Output Inductor (L_{OUT}) = 0.2 μ H.

8.1.4.2 Calculating Power Loss

- Typical Power Loss at 30 A = 4.5 W (Figure 2)
- Normalized Power Loss for switching frequency \approx 1.07 (Figure 6)
- Normalized Power Loss for input voltage \approx 1.07 (Figure 7)
- Normalized Power Loss for output voltage \approx 1.06 (Figure 8)
- Normalized Power Loss for output inductor \approx 1.02 (Figure 9)
- **Final calculated Power Loss = 4.5 W \times 1.07 \times 1.07 \times 1.06 \times 1.02 \approx 5.6 W**

8.1.4.3 Calculating SOA Adjustments

- SOA adjustment for switching frequency \approx 1.9°C (Figure 6)
- SOA adjustment for input voltage \approx 1.9°C (Figure 7)
- SOA adjustment for output voltage \approx 1.5°C (Figure 8)
- SOA adjustment for output inductor \approx 0.4°C (Figure 9)
- **Final calculated SOA adjustment = 1.9 + 1.9 + 1.5 + 0.4 \approx 5.7°C**

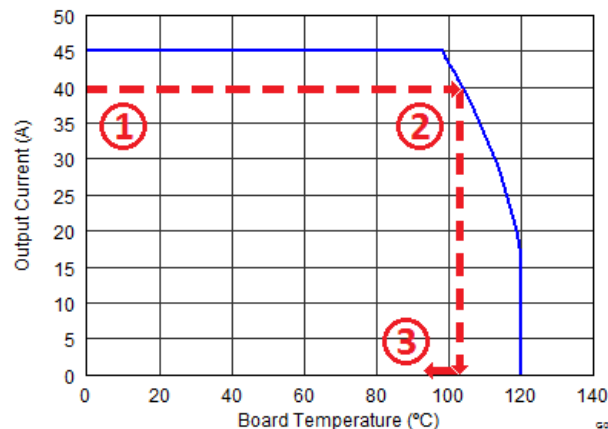

Figure 16. Power Stage CSD95373AQ5M SOA

In the previous design example, the estimated power loss of the CSD95373AQ5M would increase to 5.6 W. In addition, the maximum allowable board or ambient temperature, or both, would have to decrease by 5.7°C. Figure 16 graphically shows how the SOA curve would be adjusted accordingly.

1. Start by drawing a horizontal line from the application current to the SOA curve.
2. Draw a vertical line from the SOA curve intercept down to the board/ambient temperature.
3. Adjust the SOA board or ambient temperature by subtracting the temperature adjustment value.

In the design example, the SOA temperature adjustment yields a reduction in allowable board/ambient temperature of 5.7°C. In the event the adjustment value is a negative number, subtracting the negative number would yield an increase in allowable board or ambient temperature.

9 Layout

9.1 Layout Guidelines

9.1.1 Recommended Schematic Overview

There are several critical components that must be used in conjunction with this Power Stage device. Figure 17 shows a portion of a schematic with the critical components needed for proper operation.

- C1: Bootstrap capacitor
- R1: Bootstrap resistor
- C4: Bypass capacitor for TAO
- C3: Bypass capacitor for V_{DD}
- C5: Bypass capacitor for V_{IN} to help with ringing reduction
- C6: Bypass capacitor for V_{IN}

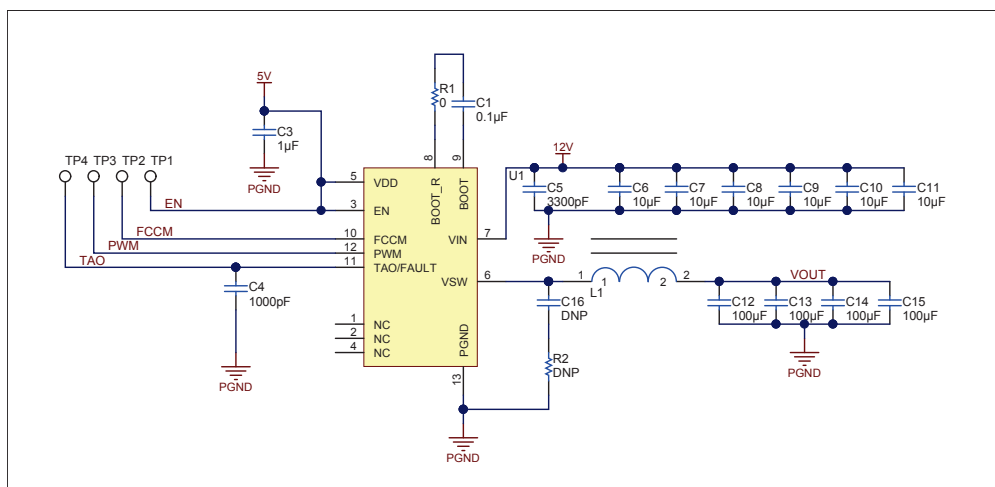

Figure 17. Recommended Schematic

9.1.2 Recommended PCB Design Overview

There are two key system-level parameters that can be addressed with a proper PCB design: electrical and thermal performance. Properly optimizing the PCB layout yields maximum performance in both areas. A brief description on how to address each parameter follows.

9.1.3 Electrical Performance

The CSD95373AQ5M has the ability to switch at voltage rates greater than 10 kV/µs. Take special care with the PCB layout design and placement of the input capacitors, inductor, and output capacitors.

- The placement of the input capacitors relative to V_{IN} and P_{GND} pins of CSD95373AQ5M device should have the highest priority during the component placement routine. It is critical to minimize these node lengths. As such, ceramic input capacitors need to be placed as close as possible to the V_{IN} and P_{GND} pins (see Figure 18). The example in Figure 18 uses 1 × 3.3 nF 0402 50 V and 6 × 10 µF 1206 25 V ceramic capacitors (TDK Part # C3216X7R1C106KT or equivalent). Notice there are ceramic capacitors on both sides of the board with an appropriate amount of vias interconnecting both layers. In terms of priority of placement next to the Power Stage C5, C8 and C6, C9 should follow in order.
- The bootstrap capacitor C_{BOOT} 0.1 µF 0603 16 V ceramic capacitor should be closely connected between BOOT and BOOT_R pins
- The switching node of the output inductor should be placed relatively close to the Power Stage CSD95373AQ5M V_{SW} pins. Minimizing the V_{SW} node length between these two components reduces the PCB conduction losses and actually reduces the switching noise level. ⁽¹⁾

(1) Keong W. Kam, David Pommerenke, "EMI Analysis Methods for Synchronous Buck Converter EMI Root Cause Analysis", University of Missouri – Rolla

Layout Guidelines (continued)

9.1.4 Thermal Performance

The CSD95373AQ5M has the ability to use the GND planes as the primary thermal path. As such, the use of thermal vias is an effective way to pull away heat from the device and into the system board. Concerns of solder voids and manufacturability problems can be addressed by the use of three basic tactics to minimize the amount of solder attach that wicks down the via barrel:

- Intentionally space out the vias from each other to avoid a cluster of holes in a given area.
- Use the smallest drill size allowed in your design. The example in [Figure 18](#) uses vias with a 10 mil drill hole and a 26 mil capture pad.
- Tent the opposite side of the via with solder-mask.

The number and drill size of the thermal vias should align with the end user's PCB design rules and manufacturing capabilities.

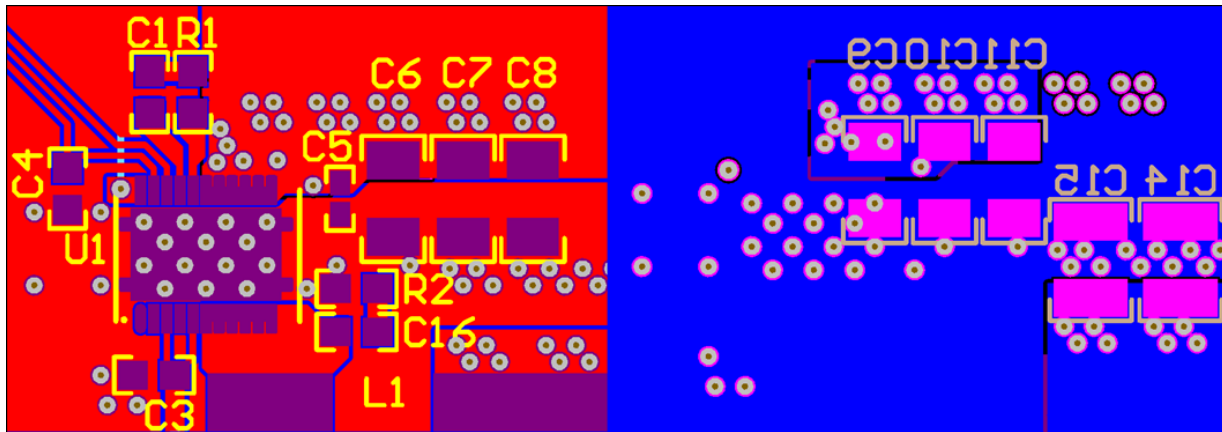

Figure 18. Recommended PCB Layout (Top-Down View)

9.1.5 Sensing Performance

The integrated temperature sensing technology built in the driver of the CSD95373AQ5M produces an analog signal that is proportional to the temperature of the lead-frame of the device, which is almost identical to the junction temperature of the Sync FET. To calculate the junction temperature based on the TAO voltage, use [Equation 2](#). TAO should be bypassed to P_{GND} with a 1 nF X7R ceramic capacitor for optimal performance. The TAO pin has limited sinking current capability to enable several power stages that are wire OR-ed together to report only the highest temperature (or fault condition if present). To ensure accurate temperature reporting, the TAO nets should be routed on a quiet inner layer between ground planes where possible. In addition, the TAO bypass capacitor should have a P_{GND} pour on the layer directly beneath to ensure proper decoupling. The TAO net should always be shielded from V_{SW} and V_{IN} whenever possible.

$$T_j[^\circ\text{C}] = (\text{TAO}[\text{mV}] - 400[\text{mV}]) / 8[\text{mV}/^\circ\text{C}] \quad (2)$$

10 Application Schematic

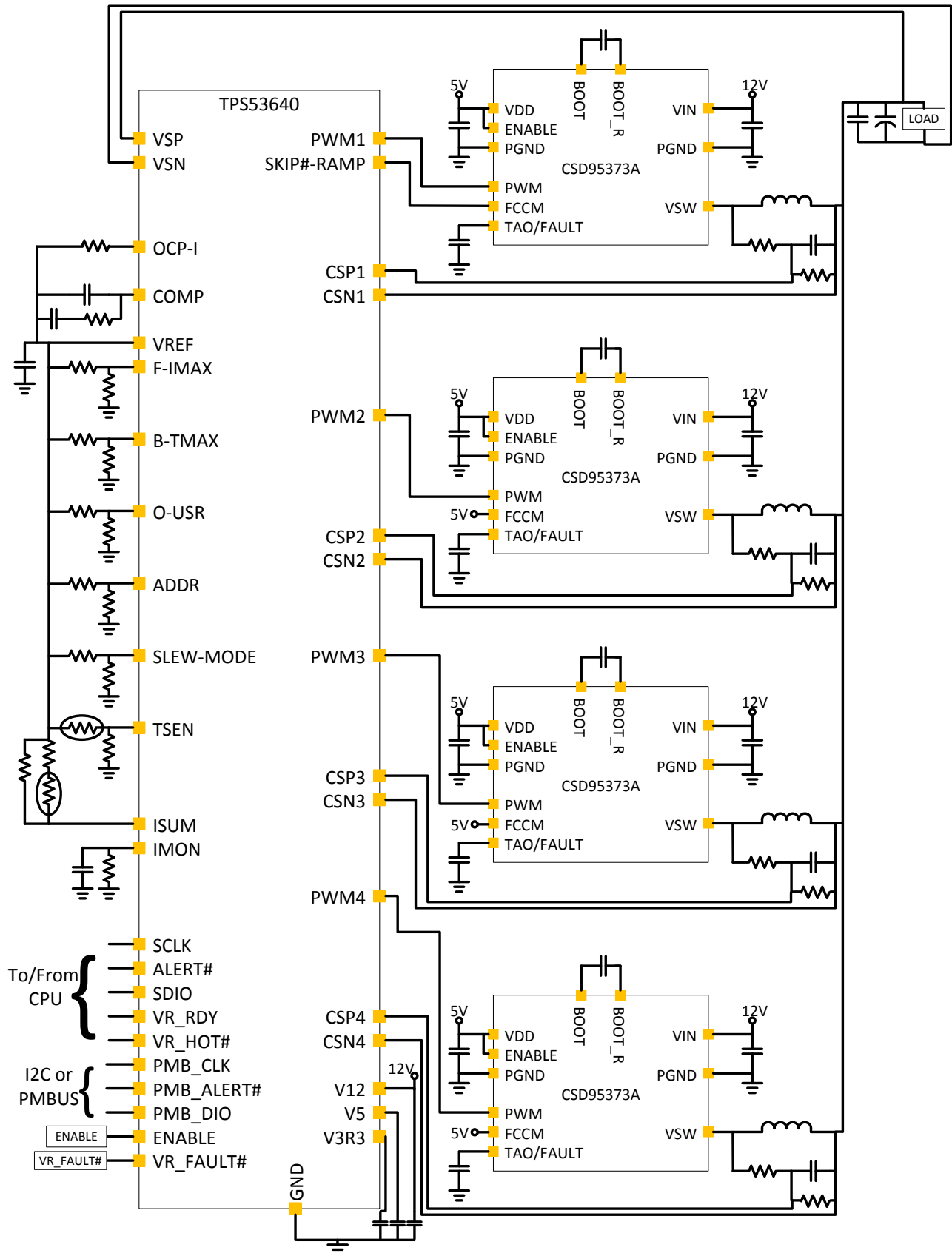

11 Device and Documentation Support

11.1 Trademarks

NexFET is a trademark of Texas Instruments.

11.2 Electrostatic Discharge Caution



These devices have limited built-in ESD protection. The leads should be shorted together or the device placed in conductive foam during storage or handling to prevent electrostatic damage to the MOS gates.

11.3 Glossary

[SLYZ022](#) — *TI Glossary*.

This glossary lists and explains terms, acronyms, and definitions.

12 Mechanical, Packaging, and Orderable Information

The following pages include mechanical, packaging, and orderable information. This information is the most current data available for the designated devices. This data is subject to change without notice and revision of this document. For browser-based versions of this data sheet, refer to the left-hand navigation.

12.1 Mechanical Drawing

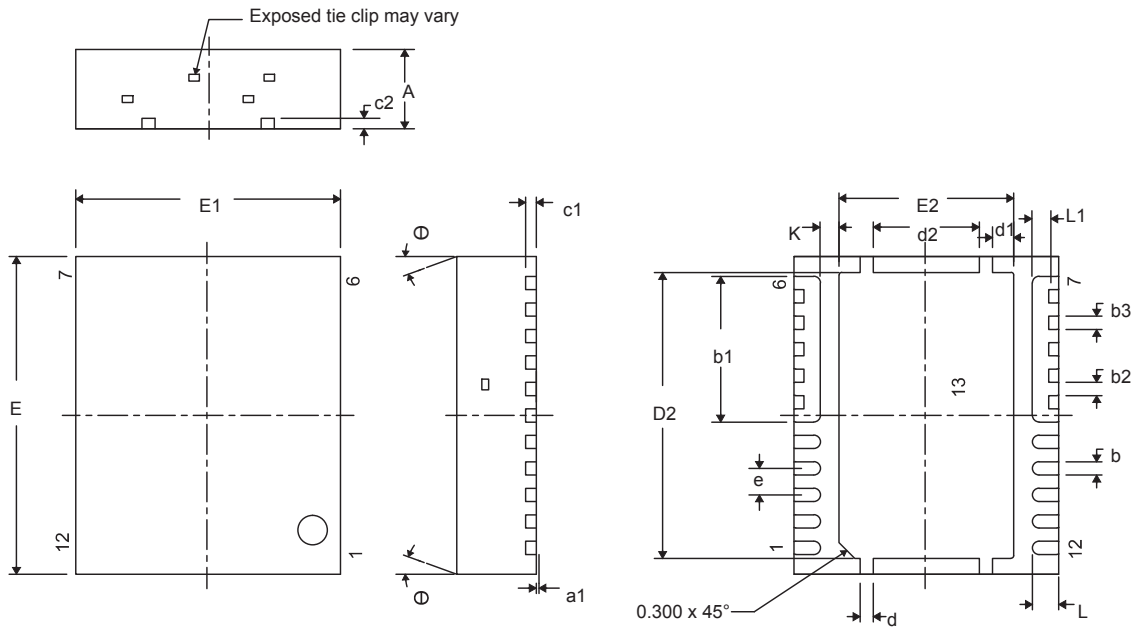

DIM	MILLIMETERS			INCHES		
	MIN	NOM	MAX	MIN	NOM	MAX
A	1.400	1.450	1.500	0.055	0.057	0.059
a1	0.000	0.000	0.050	0.000	0.000	0.002
b	0.200	0.250	0.320	0.008	0.010	0.013
b1	2.750 TYP			0.108 TYP		
b2	0.200	0.250	0.320	0.008	0.010	0.013
b3	0.250 TYP			0.010 TYP		
c1	0.150	0.200	0.250	0.006	0.008	0.010
D2	5.300	5.400	5.500	0.209	0.213	0.217
d	0.200	0.250	0.300	0.008	0.010	0.012
d1	0.350	0.400	0.450	0.014	0.016	0.018
d2	1.900	2.000	2.100	0.075	0.079	0.083
E	5.900	6.000	6.100	0.232	0.236	0.240
E1	4.900	5.000	5.100	0.193	0.197	0.201
E2	3.200	3.300	3.400	0.126	0.130	0.134
e	0.500 TYP			0.020 TYP		
K	0.350 TYP			0.014 TYP		
L	0.400	0.500	0.600	0.016	0.020	0.024
L1	0.210	0.310	0.410	0.008	0.012	0.016
θ	0.00	—	—	0.00	—	—

PACKAGING INFORMATION

Orderable Device	Status (1)	Package Type	Package Drawing	Pins	Package Qty	Eco Plan (2)	Lead finish/ Ball material (6)	MSL Peak Temp (3)	Op Temp (°C)	Device Marking (4/5)	Samples
CSD95373AQ5M	ACTIVE	LSON-CLIP	DQP	12	2500	RoHS-Exempt & Green	NIPDAU	Level-2-260C-1 YEAR	-55 to 150	95373AM	Samples

(1) The marketing status values are defined as follows:

ACTIVE: Product device recommended for new designs.

LIFEBUY: TI has announced that the device will be discontinued, and a lifetime-buy period is in effect.

NRND: Not recommended for new designs. Device is in production to support existing customers, but TI does not recommend using this part in a new design.

PREVIEW: Device has been announced but is not in production. Samples may or may not be available.

OBSOLETE: TI has discontinued the production of the device.

(2) **RoHS:** TI defines "RoHS" to mean semiconductor products that are compliant with the current EU RoHS requirements for all 10 RoHS substances, including the requirement that RoHS substance do not exceed 0.1% by weight in homogeneous materials. Where designed to be soldered at high temperatures, "RoHS" products are suitable for use in specified lead-free processes. TI may reference these types of products as "Pb-Free".

RoHS Exempt: TI defines "RoHS Exempt" to mean products that contain lead but are compliant with EU RoHS pursuant to a specific EU RoHS exemption.

Green: TI defines "Green" to mean the content of Chlorine (Cl) and Bromine (Br) based flame retardants meet JS709B low halogen requirements of <=1000ppm threshold. Antimony trioxide based flame retardants must also meet the <=1000ppm threshold requirement.

(3) MSL, Peak Temp. - The Moisture Sensitivity Level rating according to the JEDEC industry standard classifications, and peak solder temperature.

(4) There may be additional marking, which relates to the logo, the lot trace code information, or the environmental category on the device.

(5) Multiple Device Markings will be inside parentheses. Only one Device Marking contained in parentheses and separated by a "~" will appear on a device. If a line is indented then it is a continuation of the previous line and the two combined represent the entire Device Marking for that device.

(6) Lead finish/Ball material - Orderable Devices may have multiple material finish options. Finish options are separated by a vertical ruled line. Lead finish/Ball material values may wrap to two lines if the finish value exceeds the maximum column width.

Important Information and Disclaimer:The information provided on this page represents TI's knowledge and belief as of the date that it is provided. TI bases its knowledge and belief on information provided by third parties, and makes no representation or warranty as to the accuracy of such information. Efforts are underway to better integrate information from third parties. TI has taken and continues to take reasonable steps to provide representative and accurate information but may not have conducted destructive testing or chemical analysis on incoming materials and chemicals. TI and TI suppliers consider certain information to be proprietary, and thus CAS numbers and other limited information may not be available for release.

In no event shall TI's liability arising out of such information exceed the total purchase price of the TI part(s) at issue in this document sold by TI to Customer on an annual basis.

TAPE AND REEL INFORMATION

QUADRANT ASSIGNMENTS FOR PIN 1 ORIENTATION IN TAPE

*All dimensions are nominal

Device	Package Type	Package Drawing	Pins	SPQ	Reel Diameter (mm)	Reel Width W1 (mm)	A0 (mm)	B0 (mm)	K0 (mm)	P1 (mm)	W (mm)	Pin1 Quadrant
CSD95373AQ5M	LSON-CLIP	DQP	12	2500	330.0	12.4	5.3	6.3	1.8	8.0	12.0	Q1

TAPE AND REEL BOX DIMENSIONS

*All dimensions are nominal

Device	Package Type	Package Drawing	Pins	SPQ	Length (mm)	Width (mm)	Height (mm)
CSD95373AQ5M	LSON-CLIP	DQP	12	2500	346.0	346.0	33.0

IMPORTANT NOTICE AND DISCLAIMER

TI PROVIDES TECHNICAL AND RELIABILITY DATA (INCLUDING DATA SHEETS), DESIGN RESOURCES (INCLUDING REFERENCE DESIGNS), APPLICATION OR OTHER DESIGN ADVICE, WEB TOOLS, SAFETY INFORMATION, AND OTHER RESOURCES "AS IS" AND WITH ALL FAULTS, AND DISCLAIMS ALL WARRANTIES, EXPRESS AND IMPLIED, INCLUDING WITHOUT LIMITATION ANY IMPLIED WARRANTIES OF MERCHANTABILITY, FITNESS FOR A PARTICULAR PURPOSE OR NON-INFRINGEMENT OF THIRD PARTY INTELLECTUAL PROPERTY RIGHTS.

These resources are intended for skilled developers designing with TI products. You are solely responsible for (1) selecting the appropriate TI products for your application, (2) designing, validating and testing your application, and (3) ensuring your application meets applicable standards, and any other safety, security, regulatory or other requirements.

These resources are subject to change without notice. TI grants you permission to use these resources only for development of an application that uses the TI products described in the resource. Other reproduction and display of these resources is prohibited. No license is granted to any other TI intellectual property right or to any third party intellectual property right. TI disclaims responsibility for, and you will fully indemnify TI and its representatives against, any claims, damages, costs, losses, and liabilities arising out of your use of these resources.

TI's products are provided subject to [TI's Terms of Sale](#) or other applicable terms available either on [ti.com](https://www.ti.com) or provided in conjunction with such TI products. TI's provision of these resources does not expand or otherwise alter TI's applicable warranties or warranty disclaimers for TI products.

TI objects to and rejects any additional or different terms you may have proposed.

Mailing Address: Texas Instruments, Post Office Box 655303, Dallas, Texas 75265
Copyright © 2024, Texas Instruments Incorporated

Looking for pricing, stock, or lifecycle information?

Click below to explore more details on WIN SOURCE:

 [View CSD95373AQ5M](#) on WIN SOURCE

 [Texas Instruments](#) Information

Optimize Your Supply Chain with WIN SOURCE Solutions

-  Global Sourcing Solution
-  Obsolete Management
-  Cost Control Management
-  Shortage Management
-  Alternative Solution
-  Excess Inventory Management