



**THE DATASHEET OF
TPS54341DPRR**



TPS54341 4.5-V to 42-V Input, 3.5-A Step-Down DC-DC Converter With Soft-Start And Eco-Mode™

1 Features

- High Efficiency at Light Loads with Pulse Skipping Eco-mode™
- 87-mΩ High-Side MOSFET
- 152-μA Operating Quiescent Current and 2-μA Shutdown Current
- 100-kHz to 2.5-MHz Adjustable Switching Frequency
- Synchronizes to External Clock
- Low Dropout at Light Loads with Integrated BOOT Recharge FET
- Adjustable UVLO Voltage and Hysteresis
- UV and OV Power-Good Output
- Adjustable Soft-Start and Sequencing
- 0.8-V 1% Internal Voltage Reference
- 10-Pin WSON with Thermal Pad Package
- -40°C to 150°C T_J Operating Range
- Supported by WEBENCH® Software Tool

2 Applications

- Industrial Automation and Motor Control
- Vehicle Accessories: GPS and Entertainment (see *Creating GSM/GRPS Power Supply from TPS54260*, [SLVA412](#))
- USB-Dedicated Charging Ports and Battery Chargers (see *Creating a Universal Car Charger for USB devices From the TPS54240 and TPS2511*, [SLVA464](#))
- 12-V and 24-V Industrial, Automotive and Communications Power Systems

3 Description

The TPS54341 device is a 42-V, 3.5-A step-down regulator with an integrated high-side MOSFET. The device survives load-dump pulses up to 45 V per ISO 7637. Current mode control provides simple external compensation and flexible component selection. A low-ripple pulse-skip mode reduces the no-load supply current to 152 μA. Shutdown supply current is reduced to 2 μA when the enable pin is pulled low.

Undervoltage lockout is internally set at 4.3 V but can increase using an external resistor divider at the enable pin. The output voltage startup ramp is controlled by the soft start pin that can also be configured for sequencing/tracking. An open-drain power-good signal indicates the output is within 93% to 106% of the nominal voltage.

A wide adjustable switching-frequency range allows for optimization of either efficiency or external component size. Cycle-by-cycle current limit, frequency foldback and thermal shutdown protects internal and external components during an overload condition.

The TPS54341 device is available in a 10-pin 4-mm x 4-mm WSON package.

Device Information⁽¹⁾

PART NUMBER	PACKAGE	BODY SIZE (NOM)
TPS54341	WSON (10)	4.00 mm x 4.00 mm

(1) For all available packages, see the orderable addendum at the end of the data sheet.

Simplified Schematic

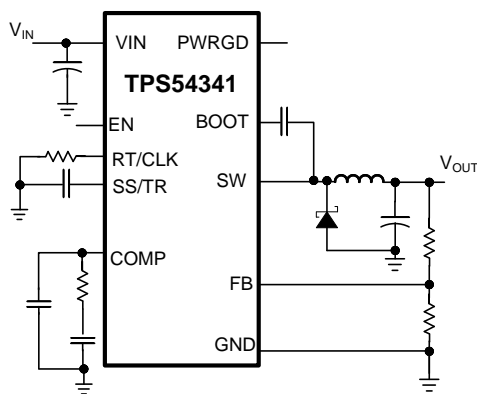

Copyright © 2016, Texas Instruments Incorporated

Efficiency vs Load Current

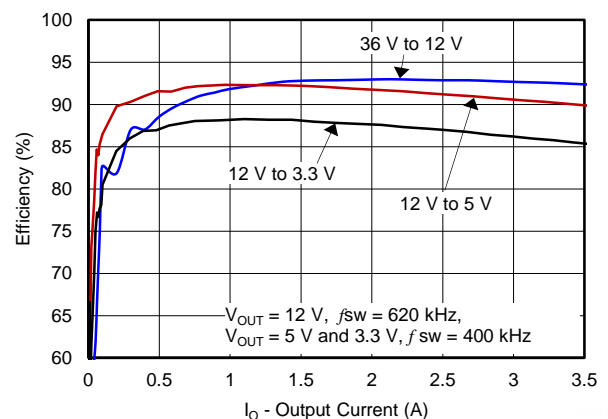

Table of Contents

1 Features	1	8 Application and Implementation	28
2 Applications	1	8.1 Application Information	28
3 Description	1	8.2 Typical Application	28
4 Revision History	2	9 Power Supply Recommendations	41
5 Pin Configuration and Functions	3	10 Layout	42
6 Specifications	4	10.1 Layout Guidelines	42
6.1 Absolute Maximum Ratings	4	10.2 Layout Example	42
6.2 ESD Ratings.....	4	11 Device and Documentation Support	43
6.3 Recommended Operating Conditions	4	11.1 Device Support	43
6.4 Thermal Information	4	11.2 Documentation Support	43
6.5 Electrical Characteristics.....	5	11.3 Receiving Notification of Documentation Updates	43
6.6 Typical Characteristics.....	7	11.4 Community Resources.....	43
7 Detailed Description	12	11.5 Trademarks	43
7.1 Overview	12	11.6 Electrostatic Discharge Caution.....	43
7.2 Functional Block Diagram	13	11.7 Glossary	43
7.3 Feature Description.....	13	12 Mechanical, Packaging, and Orderable Information	43
7.4 Device Functional Modes.....	27		

4 Revision History

Changes from Original (November 2013) to Revision A

Page

- Added *ESD Ratings* table, *Feature Description* section, *Device Functional Modes*, *Application and Implementation* section, *Power Supply Recommendations* section, *Layout* section, *Device and Documentation Support* section, and *Mechanical, Packaging, and Orderable Information* section **1**

5 Pin Configuration and Functions

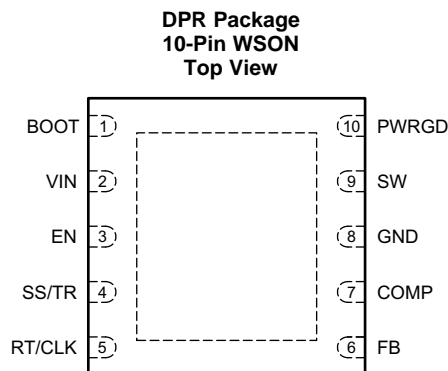

Pin Functions

PIN		I/O	DESCRIPTION
NAME	NO		
BOOT	1	O	A bootstrap capacitor is required between BOOT and SW. If the voltage on this capacitor is below the minimum required to operate the high-side MOSFET, the gate drive switches off until the capacitor refreshes.
COMP	7	O	Error amplifier output and input to the output switch current (PWM) comparator. Connect frequency compensation components to this pin.
EN	3	I	Enable pin, with internal pullup current source. Pull below 1.2 V to disable. Float to enable. Adjust the input undervoltage lockout with two resistors. See Enable and Adjusting Undervoltage Lockout for more information.
FB	6	I	Inverting input of the transconductance (gm) error amplifier.
GND	8	—	Ground
PWRGD	10	O	Power Good is an open drain output that asserts low if the output voltage is out of regulation due to thermal shutdown, dropout, over-voltage or EN shut down
RT/CLK	5	I	Resistor Timing and External Clock. An internal amplifier holds this pin at a fixed voltage when using an external resistor to ground to set the switching frequency. If the pin is pulled above the PLL upper threshold, a mode change occurs and the pin becomes a synchronization input. The internal amplifier is disabled and the pin is a high-impedance clock input to the internal PLL. If clocking edges stop, the internal amplifier re-enables and the operating mode returns to resistor frequency programming.
SS/TR	4	I	Soft-start and tracking. An external capacitor connected to this pin sets the output rise time. Because the voltage on this pin overrides the internal reference, SS/TR can be used for tracking and sequencing.
SW	9	I	The source of the internal high-side power MOSFET and switching node of the converter.
Thermal Pad	—	—	The GND pin must be electrically connected to the exposed pad on the printed circuit board for proper operation.
VIN	2	I	Input supply voltage with 4.5-V to 42-V operating range.

6 Specifications

6.1 Absolute Maximum Ratings

 over operating free-air temperature range (unless otherwise noted)⁽¹⁾

		MIN	MAX	UNIT
Input voltage	V _{IN}	-0.3	45	V
	EN	-0.3	8.4	
	BOOT		53	
	FB	-0.3	3	
	COMP	-0.3	3	
	PWRGD	-0.3	6	
	SS/TR	-0.3	3	
	RT/CLK	-0.3	3.6	
Output voltage	BOOT-SW		8	V
	SW	-0.6	45	
	SW, transient (10 ns)	-2	45	
Operating junction temperature, T _J		-40	150	°C
Storage temperature, T _{stg}		-65	150	°C

- (1) Stresses beyond those listed under *Absolute Maximum Ratings* may cause permanent damage to the device. These are stress ratings only, which do not imply functional operation of the device at these or any other conditions beyond those indicated under *Recommended Operating Conditions*. Exposure to absolute-maximum-rated conditions for extended periods may affect device reliability.

6.2 ESD Ratings

		VALUE	UNIT
V _(ESD) Electrostatic discharge	Human-body model (HBM), per ANSI/ESDA/JEDEC JS-001 ⁽¹⁾	±2000	V
	Charged-device model (CDM), per JEDEC specification JESD22-C101 ⁽²⁾	±500	

- (1) JEDEC document JEP155 states that 500-V HBM allows safe manufacturing with a standard ESD control process.
 (2) JEDEC document JEP157 states that 250-V CDM allows safe manufacturing with a standard ESD control process.

6.3 Recommended Operating Conditions

over operating free-air temperature range (unless otherwise noted)

		MIN	MAX	UNIT
V _{IN}	Supply input voltage	4.5	42	V
V _O	Output voltage	0.8	41.1	V
I _O	Output current	0	3.5	A
T _J	Junction Temperature	-40	150	°C

6.4 Thermal Information

THERMAL METRIC ⁽¹⁾⁽²⁾		TPS54341	UNIT
		DPR (WSON)	
		10 PINS	
R _{θJA}	Junction-to-ambient thermal resistance	35.1	°C/W
R _{θJC(top)}	Junction-to-case (top) thermal resistance	34.1	°C/W
R _{θJB}	Junction-to-board thermal resistance	12.3	°C/W
ψ _{JT}	Junction-to-top characterization parameter	0.3	°C/W
ψ _{JB}	Junction-to-board characterization parameter	12.5	°C/W
R _{θJC(bot)}	Junction-to-case (bottom) thermal resistance	2.2	°C/W

- (1) For more information about traditional and new thermal metrics, see the *Semiconductor and IC Package Thermal Metrics* application report.
 (2) Power rating at a specific ambient temperature T_A should be determined with a junction temperature of 150°C. This is the point where distortion starts to substantially increase. See power dissipation estimate in application section of this data sheet for more information.

6.5 Electrical Characteristics

 $T_J = -40^{\circ}\text{C}$ to 150°C , $V_{IN} = 4.5\text{ V}$ to 42 V (unless otherwise noted)

PARAMETER	TEST CONDITIONS	MIN	TYP	MAX	UNIT
SUPPLY VOLTAGE (VIN PIN)					
Operating input voltage		4.5		42	V
Internal undervoltage lockout threshold	Rising	4.1	4.3	4.48	V
Internal undervoltage lockout threshold hysteresis			325		mV
Shutdown supply current	$EN = 0\text{ V}$, 25°C , $4.5\text{ V} \leq V_{IN} \leq 42\text{ V}$		2.25	4.5	μA
Operating: nonswitching supply current	$FB = 0.9\text{ V}$, $T_A = 25^{\circ}\text{C}$		152	200	μA
ENABLE AND UVLO (EN PIN)					
Enable threshold voltage	No voltage hysteresis, rising and falling	1.1	1.2	1.3	V
Input current	Enable threshold = 50 mV		-4.6		μA
	Enable threshold = -50 mV	-0.58	-1.2	-1.8	μA
Hysteresis current		-2.2	-3.4	-4.5	μA
Enable to COMP active	$V_{IN} = 12\text{ V}$, $T_A = 25^{\circ}\text{C}$		540		μs
VOLTAGE REFERENCE					
Voltage reference		0.792	0.8	0.808	V
HIGH-SIDE MOSFET					
On-resistance	$V_{IN} = 12\text{ V}$, $BOOT-SW = 6\text{ V}$		87	185	$\text{m}\Omega$
ERROR AMPLIFIER					
Input current			50		nA
Error amplifier transconductance (gm)	$-2\text{ }\mu\text{A} < I_{COMP} < 2\text{ }\mu\text{A}$, $V_{COMP} = 1\text{ V}$		350		μMhos
Error amplifier transconductance (gm) during soft-start	$-2\text{ }\mu\text{A} < I_{COMP} < 2\text{ }\mu\text{A}$, $V_{COMP} = 1\text{ V}$, $V_{FB} = 0.4\text{ V}$		77		μMhos
Error amplifier DC gain	$V_{FB} = 0.8\text{ V}$		10000		V/V
Min unity gain bandwidth			2500		kHz
Error amplifier source and sink	$V_{(COMP)} = 1\text{ V}$, 100-mV overdrive		± 30		μA
COMP to SW current transconductance			12		A/V
CURRENT LIMIT					
Current limit threshold	All V_{IN} and temperatures, open loop ⁽¹⁾	4.5	5.5	6.8	A
	All temperatures, $V_{IN} = 12\text{ V}$, open loop ⁽¹⁾	4.5	5.5	6.3	
	$V_{IN} = 12\text{ V}$, $T_A = 25^{\circ}\text{C}$, open loop ⁽¹⁾	5.2	5.5	5.9	
Current limit threshold delay			60		ns
THERMAL SHUTDOWN					
Thermal shutdown			176		$^{\circ}\text{C}$
Thermal shutdown hysteresis			12		$^{\circ}\text{C}$
TIMING RESISTOR AND EXTERNAL CLOCK (RT/CLK PIN)					
Switching frequency range using RT mode		100		2500	kHz
f_{SW} Switching frequency	$R_T = 200\text{ k}\Omega$	450	500	550	kHz
Switching frequency range using CLK mode		160		2300	kHz
Minimum CLK input pulse width			15		ns
RT/CLK high threshold			1.55	2	V
RT/CLK low threshold		0.5	1.2		V
RT/CLK falling edge to SW rising edge delay	Measured at 500 kHz with RT resistor in series		55		ns
PLL lock in time	Measured at 500 kHz		78		μs
SOFT START AND TRACKING (SS/TR PIN)					
Charge current	$V_{SS/TR} = 0.4\text{ V}$		1.7		μA
SS/TR-to-FB matching	$V_{SS/TR} = 0.4\text{ V}$		42		mV
SS/TR-to-reference crossover	98% nominal		1.16		V
SS/TR discharge current (overload)	$FB = 0\text{ V}$, $V_{SS/TR} = 0.4\text{ V}$		354		μA
SS/TR discharge voltage	$FB = 0\text{ V}$		54		mV

(1) Open Loop current limit measured directly at the SW pin and is independent of the inductor value and slope compensation.

Electrical Characteristics (continued)
 $T_J = -40^{\circ}\text{C}$ to 150°C , $V_{IN} = 4.5\text{ V}$ to 42 V (unless otherwise noted)

PARAMETER	TEST CONDITIONS	MIN	TYP	MAX	UNIT
POWER GOOD (PWRGD PIN)					
FB threshold for PWRGD low	FB falling		90%		
FB threshold for PWRGD high	FB rising		93%		
FB threshold for PWRGD low	FB rising		108%		
FB threshold for PWRGD high	FB falling		106%		
Hysteresis	FB falling		2.5%		
Output high leakage	$V_{PWRGD} = 5.5\text{ V}$, $T_A = 25^{\circ}\text{C}$		10		nA
On resistance	$I_{PWRGD} = 3\text{ mA}$, $V_{FB} < 0.79\text{ V}$		45		Ω
Minimum V_{IN} for defined output	$V_{PWRGD} < 0.5\text{ V}$, $I_{PWRGD} = 100\ \mu\text{A}$		0.9	2	V

6.6 Typical Characteristics

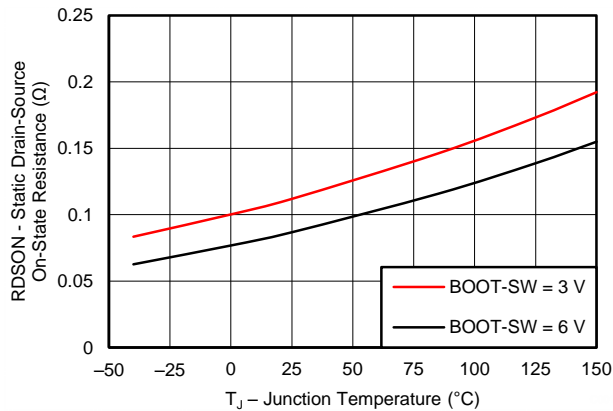

Figure 1. On Resistance vs Junction Temperature

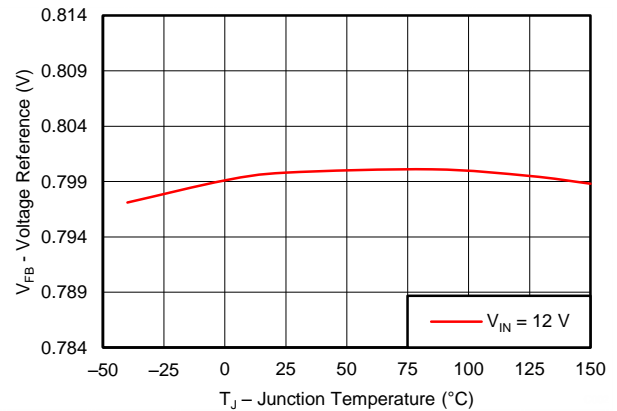

Figure 2. Voltage Reference vs Junction Temperature

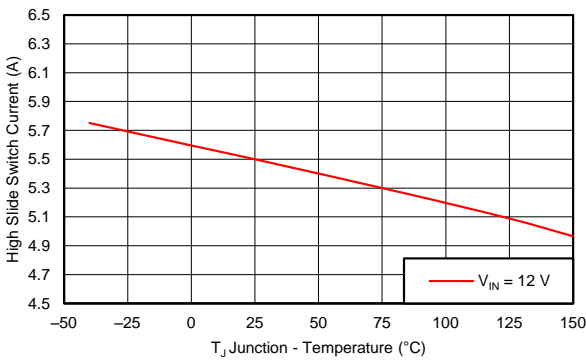

Figure 3. Switch Current Limit vs Junction Temperature

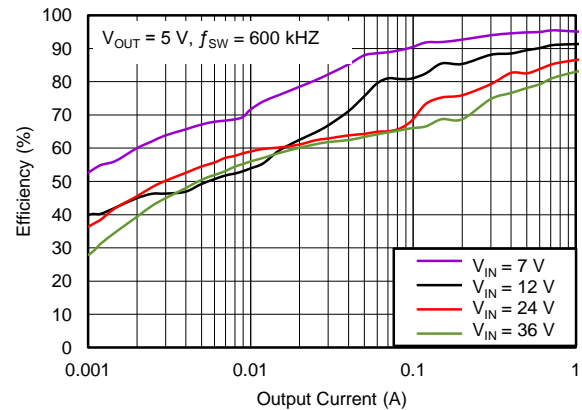

Figure 4. Switch Current Limit vs Input Voltage

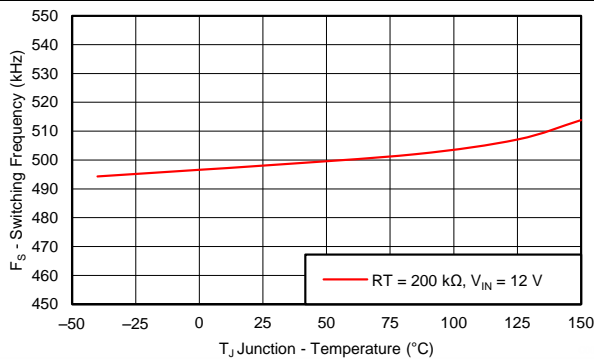

Figure 5. Switching Frequency vs Junction Temperature

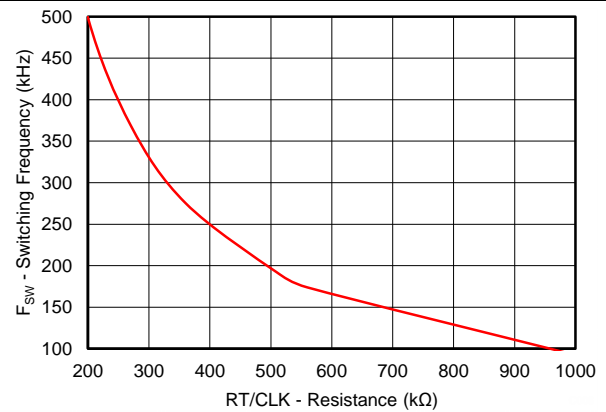

Figure 6. Switching Frequency vs RT/CLK Resistance Low Frequency Range

Typical Characteristics (continued)

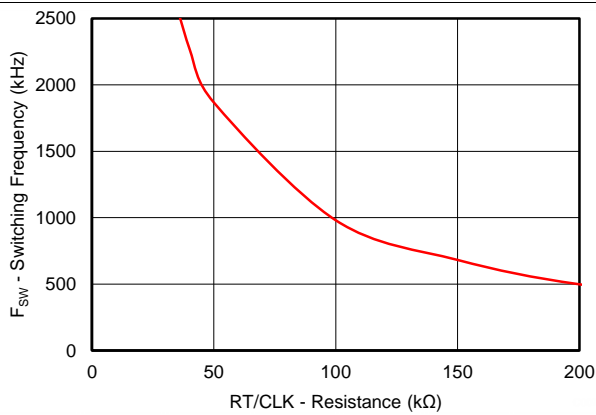

Figure 7. Switching Frequency vs RT/CLK Resistance High Frequency Range

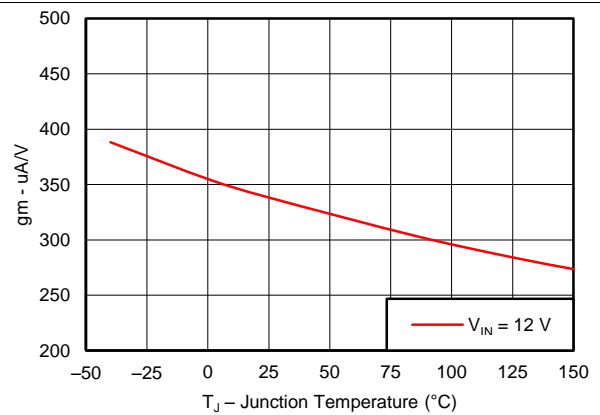

Figure 8. EA Transconductance vs Junction Temperature

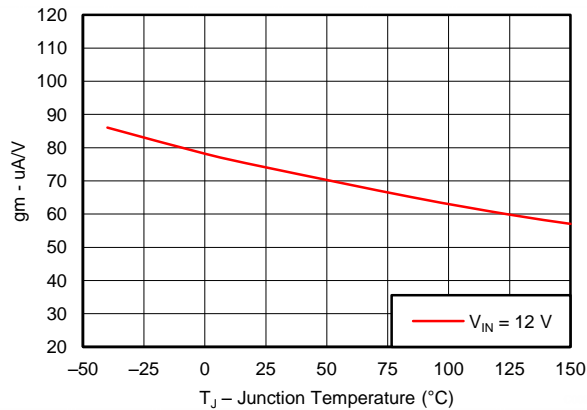

Figure 9. EA Transconductance During Soft-Start vs Junction Temperature

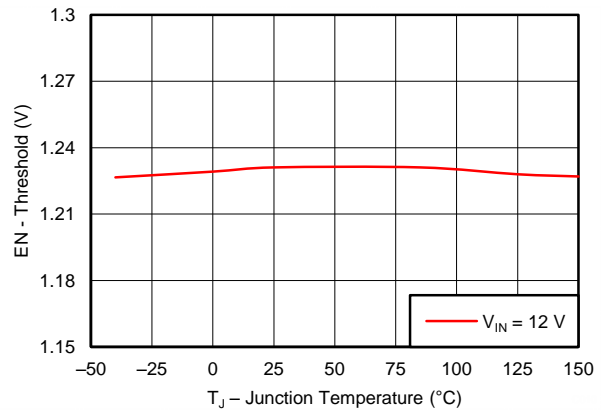

Figure 10. EN Pin Voltage vs Junction Temperature

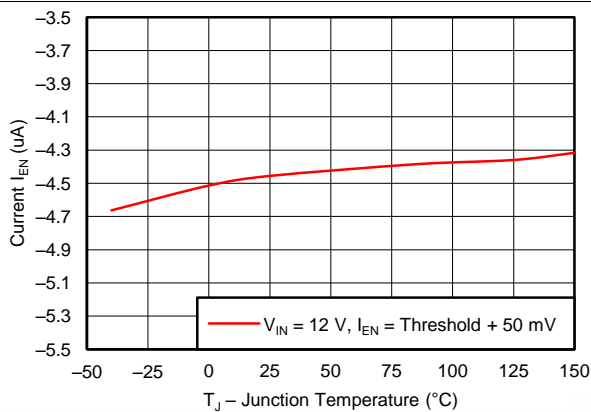

Figure 11. EN Pin Current vs Junction Temperature

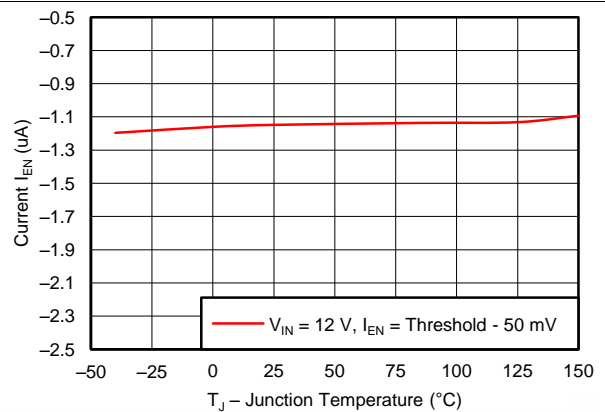

Figure 12. EN Pin Current vs Junction Temperature

Typical Characteristics (continued)

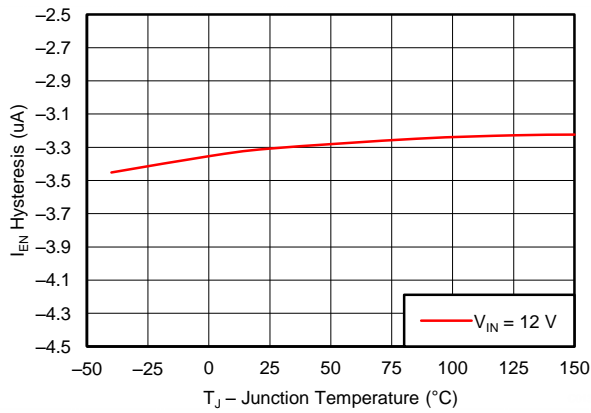

Figure 13. EN Pin Current Hysteresis vs Junction Temperature

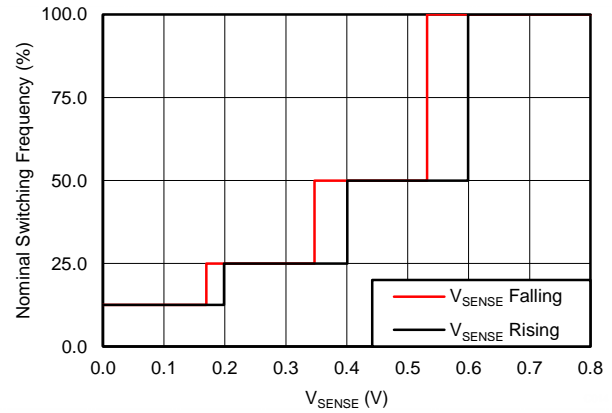

Figure 14. Switching Frequency vs FB

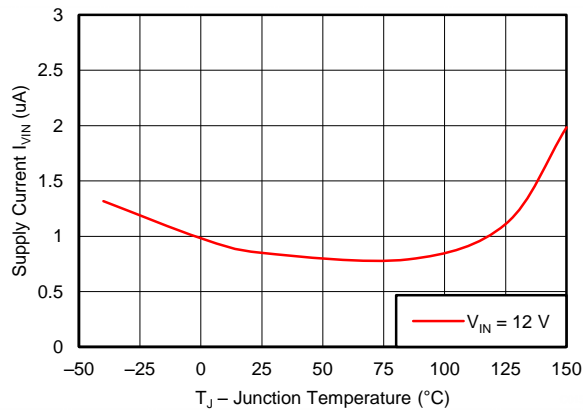

Figure 15. Shutdown Supply Current vs Junction Temperature

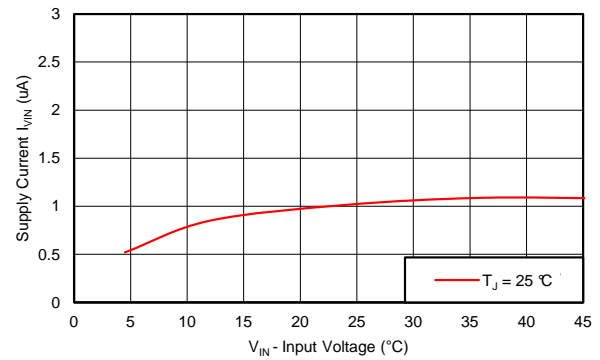

Figure 16. Shutdown Supply Current vs Input Voltage (V_{IN})

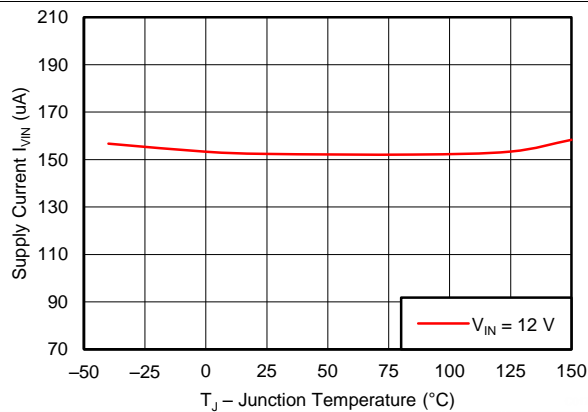

Figure 17. V_{IN} Supply Current vs Junction Temperature

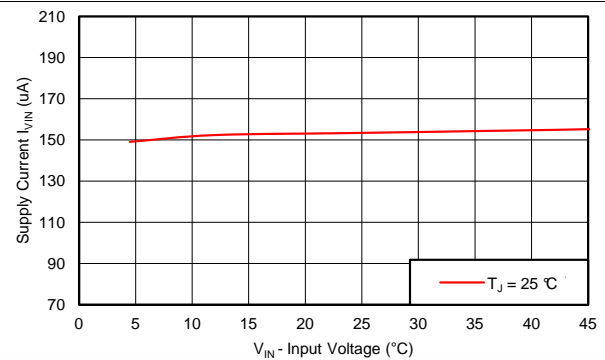

Figure 18. V_{IN} Supply Current vs Input Voltage

Typical Characteristics (continued)

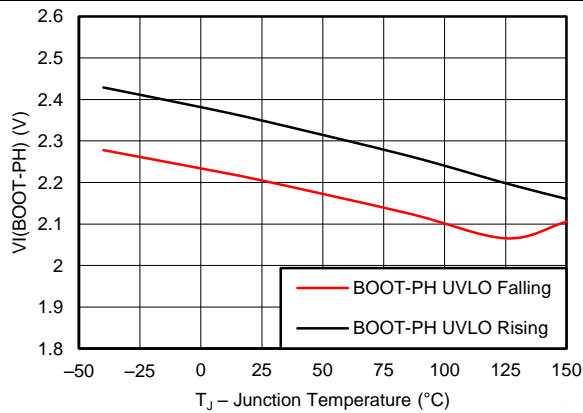

Figure 19. BOOT-SW UVLO vs Junction Temperature

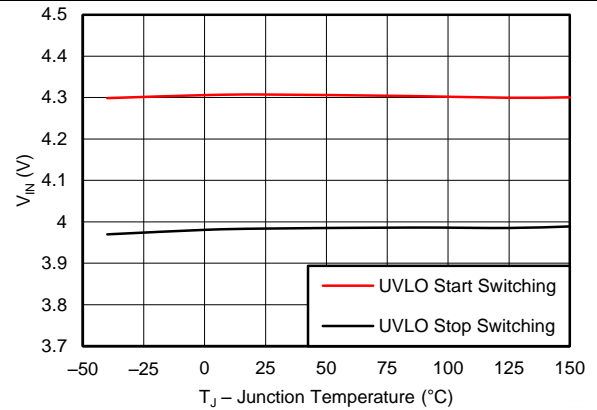

Figure 20. Input Voltage UVLO vs Junction Temperature

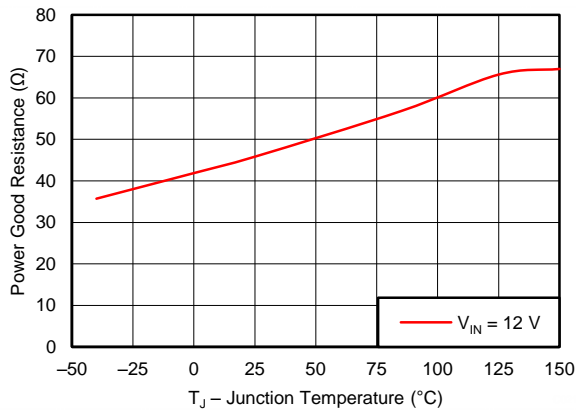

Figure 21. PWRGD On Resistance vs Junction Temperature

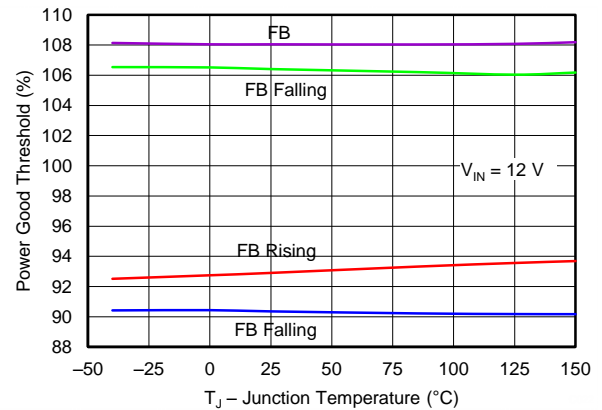

Figure 22. PWRGD Threshold vs Junction Temperature

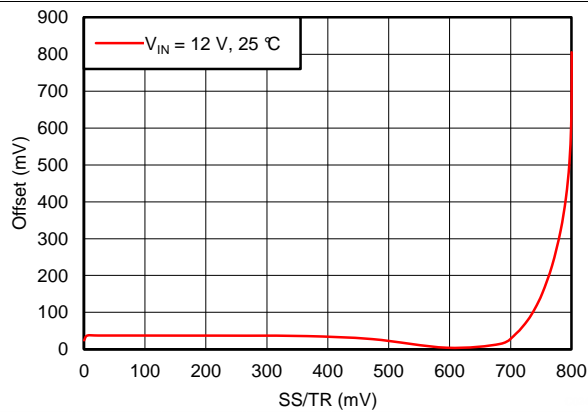

Figure 23. SS/TR to FB Offset vs FB

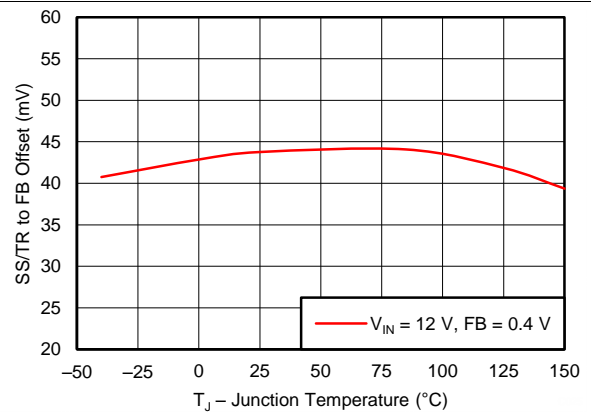

Figure 24. SS/TR to FB Offset vs Temperature

Typical Characteristics (continued)

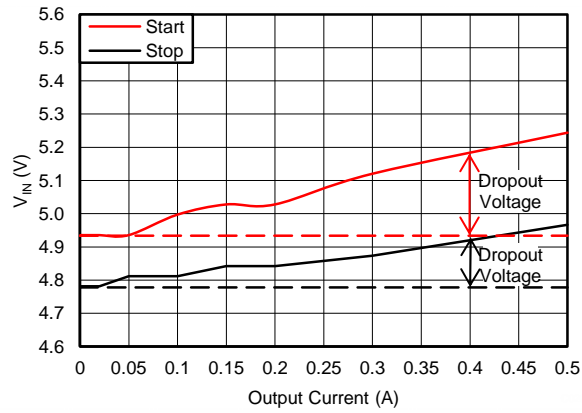

Figure 25. 5-V Start and Stop Voltage (see [Low Dropout Operation and Bootstrap Voltage \(BOOT\)](#))

7 Detailed Description

7.1 Overview

The TPS54341 device is a 42-V 3.5-A, step-down (buck) regulator with an integrated high-side n-channel MOSFET. The device implements constant-frequency current-mode control which reduces output capacitance and simplifies external frequency compensation. The wide switching frequency range of 100 kHz to 2500 kHz allows for either efficiency or size optimization when selecting the output filter components. The switching frequency is adjusted using a resistor to ground connected to the RT/CLK pin. The device has an internal phase-locked loop (PLL) connected to the RT/CLK pin that synchronizes the power switch turn-on to a falling edge of an external clock signal.

The TPS54341 device has a default input-startup voltage of 4.3 V typical. The EN pin adjusts the input-voltage undervoltage-lockout (UVLO) threshold with two external resistors. An internal-pullup current source enables operation when the EN pin is floating. The operating current is 152 μ A under a no-load condition when not switching. When the device is disabled, the supply current is 2 μ A.

The integrated 87-m Ω high-side MOSFET supports high-efficiency power-supply designs capable of delivering 3.5 A of continuous current to a load. The gate-drive bias voltage for the integrated high-side MOSFET is supplied by a bootstrap capacitor connected from the BOOT to SW pins. The TPS54341 device reduces the external component count by integrating the bootstrap recharge diode. The BOOT pin capacitor voltage is monitored by a UVLO circuit which turns off the high-side MOSFET when the BOOT to SW voltage falls below a preset threshold. An automatic BOOT capacitor recharge circuit allows the TPS54341 device to operate at high duty cycles approaching 100%. Therefore, the maximum output voltage is near the minimum input supply voltage of the application. The minimum output voltage is the internal 0.8-V feedback reference.

Output overvoltage transients are minimized by an Overvoltage Protection (OVP) comparator. When the OVP comparator is activated, the high-side MOSFET turns off and remains off until the output voltage is less than 106% of the desired output voltage.

The SS/TR (soft-start/tracking) pin minimizes inrush currents or provides power-supply sequencing during power up. A small value capacitor must be connected to the pin to adjust the soft-start time. A resistor divider can be connected to the pin for critical power-supply sequencing requirements. The SS/TR pin is discharged before the output powers up. This discharging ensures a repeatable restart after an overtemperature fault, UVLO fault, or a disabled condition. When the overload condition is removed, the soft-start circuit controls the recovery from the fault output level to the nominal regulation voltage. A frequency-foldback circuit reduces the switching frequency during startup and overcurrent fault conditions to help maintain control of the inductor current.

7.2 Functional Block Diagram

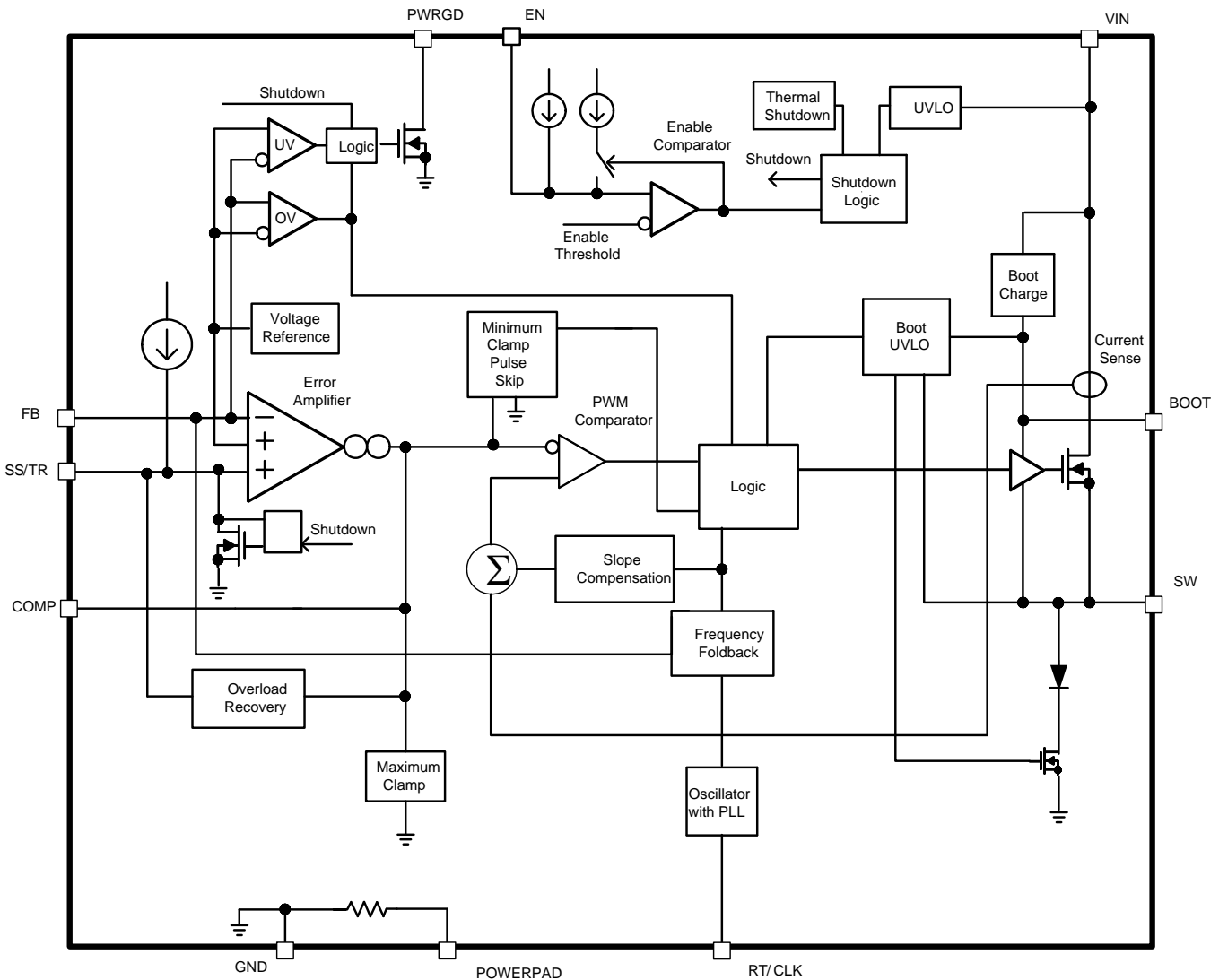

Copyright © 2016, Texas Instruments Incorporated

7.3 Feature Description

7.3.1 Fixed Frequency PWM Control

The TPS54341 device uses fixed-frequency peak-current-mode control with adjustable switching frequency. The output voltage is compared through external resistors connected to the FB pin to an internal voltage reference by an error amplifier. An internal oscillator initiates the turn-on of the high-side power switch. The error amplifier output at the COMP pin controls the high-side power switch current. When the high-side MOSFET switch current reaches the threshold level set by the COMP voltage, the power switch turns off. The COMP pin voltage increases and decreases as the output current increases and decreases. The device implements current limiting by clamping the COMP pin voltage to a maximum level. The pulse skipping Eco-mode is implemented with a minimum voltage clamp on the COMP pin.

7.3.2 Slope Compensation Output Current

The TPS54341 device adds a compensating ramp to the MOSFET switch current-sense signal. This slope compensation prevents sub-harmonic oscillations at duty cycles greater than 50%. The peak current limit of the high-side switch is not affected by the slope compensation and remains constant over the full duty-cycle range.

Feature Description (continued)

7.3.3 Low Dropout Operation and Bootstrap Voltage (BOOT)

The TPS54341 device provides an integrated bootstrap-voltage regulator. A small capacitor between the BOOT and SW pins provides the gate-drive voltage for the high-side MOSFET. The BOOT capacitor refreshes when the high-side MOSFET is off and the external low-side diode conducts. The recommended value of the BOOT capacitor is 0.1 μF . A ceramic capacitor with an X7R or X5R grade dielectric with a voltage rating of 10 V or higher is recommended for stable performance over temperature and voltage.

When operating with a low voltage difference from input to output, the high-side MOSFET of the TPS54341 device operates at 100% duty cycle as long as the BOOT to SW pin voltage is greater than 2.1 V. When the voltage from BOOT to SW drops below 2.1 V, the high-side MOSFET turns off and an integrated low-side MOSFET pulls SW low to recharge the BOOT capacitor. To reduce the losses of the small low-side MOSFET at high output voltages, the low-side MOSFET is disabled at 24 V output and re-enabled when the output reaches 21.5 V.

Because the gate-drive current sourced from the BOOT capacitor is small, the high-side MOSFET remains on for many switching cycles before the MOSFET turns off to refresh the capacitor. Thus the effective duty cycle of the switching regulator can be high, approaching 100%. The effective duty cycle of the converter during dropout is mainly influenced by the voltage drops across the power MOSFET, the inductor resistance, the low-side diode voltage, and the printed circuit-board resistance.

The start and stop voltage for a typical 5-V output application is shown in [Figure 25](#) where the input voltage is plotted versus load current. The start voltage is defined as the input voltage required to regulate the output within 1% of nominal. The stop voltage is defined as the input voltage at which the output drops by 5% or where switching stops.

During high duty-cycle (low dropout) conditions, inductor current-ripple increases when the BOOT capacitor recharges resulting in an increase in output-voltage ripple. Increased ripple occurs when the off time required to recharge the BOOT capacitor is longer than the high-side off time associated with cycle-by-cycle PWM control.

At heavy loads, the minimum input voltage must increase to ensure a monotonic startup. [Equation 1](#) calculates the minimum input voltage for this condition.

$$V_{\text{OUT(max)}} = D_{\text{(max)}} \times (V_{\text{IN(min)}} - I_{\text{OUT(max)}} \times R_{\text{DS(on)}} + V_{\text{d}}) - V_{\text{d}} + I_{\text{OUT(max)}} \times R_{\text{dc}}$$

where

- $D_{\text{(max)}} \geq 0.9$
 - V_{d} = forward drop of the catch diode
 - $V_{\text{BOOT}} = (1.41 \times V_{\text{IN}} - 0.554 - V_{\text{d}} \times f_{\text{SW}} - 1.847 \times 10^3 \times \text{IB2SW}) / (1.41 + f_{\text{SW}})$
 - $R_{\text{DS(on)}} = 1 / (-0.3 \times \text{VB2SW}^2 + 3.577 \times \text{VB2SW} - 4.246)$
 - $\text{IB2SW} = 100 \mu\text{A}$
 - $\text{VB2SW} = V_{\text{BOOT}} + V_{\text{d}}$
- (1)

7.3.4 Error Amplifier

A transconductance error amplifier controls the TPS54341 device voltage-regulation loop. The error amplifier compares the FB pin voltage to the lower of the internal soft-start voltage or the internal 0.8-V voltage reference. The transconductance (gm) of the error amplifier is 350 $\mu\text{A/V}$ during normal operation. During soft-start operation, the transconductance is reduced to 78 $\mu\text{A/V}$ and the error amplifier is referenced to the internal soft-start voltage.

The frequency compensation components (capacitor, series resistor, and capacitor) are connected between the error amplifier output COMP pin and GND pin.

7.3.5 Adjusting the Output Voltage

The internal voltage reference produces a precise 0.8-V $\pm 1\%$ voltage reference over the operating temperature and voltage range by scaling the output of a bandgap-reference circuit. The output voltage is set by a resistor divider from the output node to the FB pin. Using 1% tolerance or better divider resistors is recommended. Select the low-side resistor R_{LS} for the desired divider current and use [Equation 2](#) to calculate R_{HS} . To improve efficiency at light loads consider using larger value resistors. However, if the values are too high, the regulator is more susceptible to noise and voltage errors from the FB input current may become noticeable.

Feature Description (continued)

$$R_{HS} = R_{LS} \times \left(\frac{V_{out} - 0.8V}{0.8V} \right) \tag{2}$$

7.3.6 Enable and Adjusting Undervoltage Lockout

The TPS54341 device enables when the VIN pin voltage rises above 4.3 V and the EN pin voltage exceeds the enable threshold of 1.2 V. The TPS54341 device disables when the VIN pin voltage falls below 4 V or when the EN pin voltage is below 1.2 V. The EN pin has an internal pullup-current source, I_1 , of 1.2 μ A that enables operation of the TPS54341 device when the EN pin floats.

If an application requires a higher undervoltage-lockout (UVLO) threshold, use the circuit shown in [Figure 26](#) to adjust the input-voltage UVLO with two external resistors. When the EN pin voltage exceeds 1.2 V, an additional 3.4 μ A of hysteresis current, I_{HYS} , is sourced out of the EN pin. When the EN pin pulls below 1.2 V, the 3.4- μ A I_{HYS} current is removed. This additional current facilitates adjustable input-voltage UVLO hysteresis. Use [Equation 3](#) to calculate R_{UVLO1} for the desired UVLO hysteresis voltage. Use [Equation 4](#) to calculate R_{UVLO2} for the desired VIN start voltage.

In applications designed to start at relatively low input voltages (that is, from 4.5 to 9 V) and withstand high input voltages (for example, 40 V), the EN pin can experience a voltage greater than the absolute maximum voltage of 8.4 V during the high-input voltage condition. To avoid exceeding this voltage when using the EN resistors, the EN pin is clamped internally with a 5.8-V Zener diode capable of sinking up to 150 μ A.

$$R_{UVLO1} = \frac{V_{START} - V_{STOP}}{I_{HYS}} \tag{3}$$

$$R_{UVLO2} = \frac{V_{ENA}}{\frac{V_{START} - V_{ENA}}{R_{UVLO1}} + I_1} \tag{4}$$

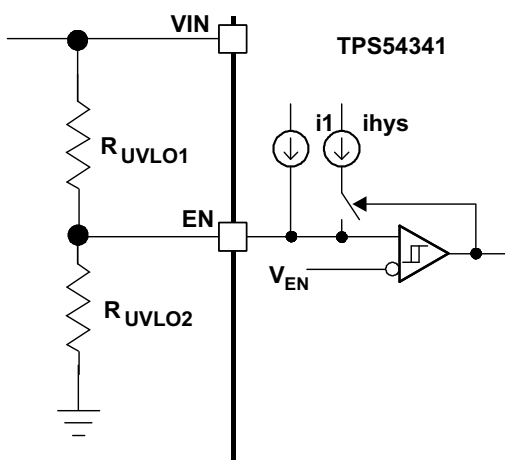

Copyright © 2016, Texas Instruments Incorporated

Figure 26. Adjustable UVLO

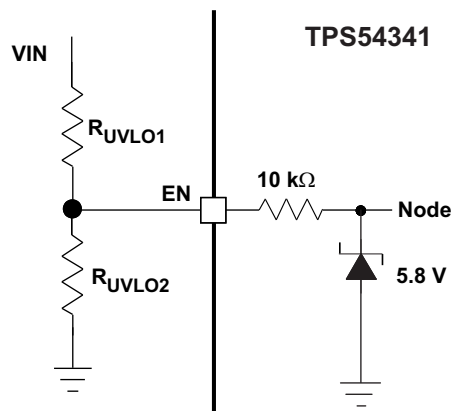

Copyright © 2016, Texas Instruments Incorporated

Figure 27. Internal EN Pin Clamp

Feature Description (continued)

7.3.7 Soft-Start/Tracking Pin (SS/TR)

The TPS54341 device effectively uses the lower voltage of the internal voltage reference or the SS/TR pin voltage as the reference voltage of the power-supply and regulates the output accordingly. A capacitor on the SS/TR pin to ground implements a soft-start time. The TPS54341 device has an internal pullup-current source of 1.7 μA that charges the external soft-start capacitor. The calculations for the soft-start time (10% to 90%) are shown in Equation 5. The voltage reference (V_{REF}) is 0.8 V and the soft-start current (I_{SS}) is 1.7 μA . The soft-start capacitor should remain lower than 0.47 μF and greater than 0.47 nF.

$$C_{\text{SS}} \text{ (nF)} = \frac{T_{\text{SS}} \text{ (ms)} \times I_{\text{SS}} \text{ (\mu A)}}{V_{\text{REF}} \text{ (V)} \times 0.8} \quad (5)$$

At power up, the TPS54341 device does not start switching until the soft-start pin discharges to less than 54 mV to ensure a proper power-up, see Figure 28.

Also, during normal operation, the TPS54341 device stops switching and the SS/TR must discharge to 54 mV, when the VIN UVLO is exceeded, the EN pin pulls below 1.2 V, otherwise a thermal shutdown event occurs.

The FB voltage follows the SS/TR pin voltage with a 42-mV offset up to 85% of the internal voltage reference. When the SS/TR voltage is greater than 85% on the internal reference voltage the offset increases as the effective system reference transitions from the SS/TR voltage to the internal voltage reference (see Figure 23). The SS/TR voltage ramps linearly until clamped at 2.7 V typically as shown in Figure 28.

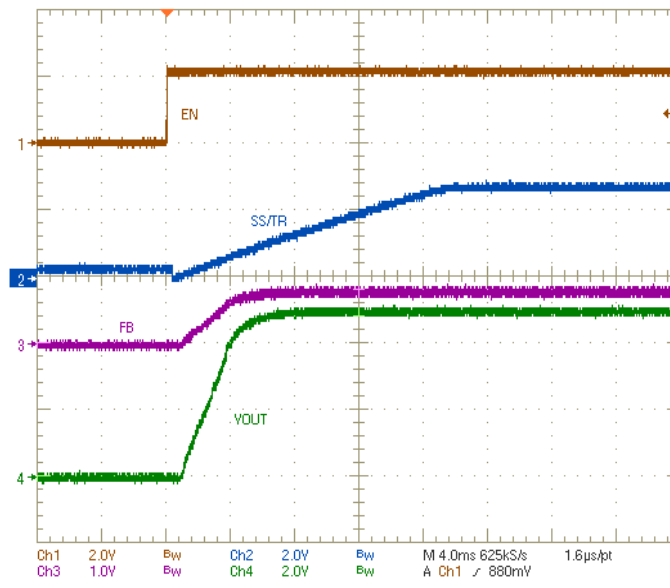
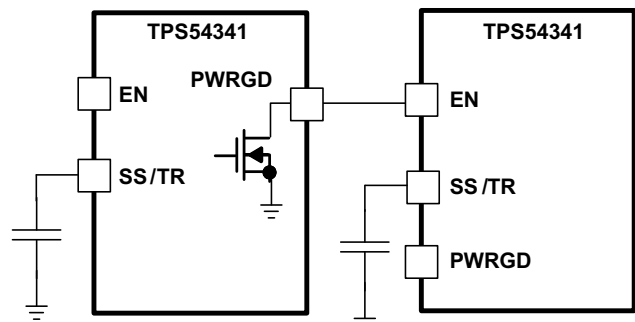

Figure 28. Operation of SS/TR Pin When Starting

7.3.8 Sequencing

Many of the common power-supply sequencing methods are implemented using the SS/TR, EN, and PWRGD pins. The sequential method is implemented using an open-drain output of a power-on reset pin of another device. The sequential method is illustrated in Figure 29 using two TPS54341 devices. The power good is connected to the EN pin on the TPS54341 device which enables the second power supply once the primary supply reaches regulation. If needed, a 1-nF ceramic capacitor on the EN pin of the second power supply provides a 1-ms startup delay. Figure 30 shows the results of Figure 29.

Feature Description (continued)



Copyright © 2016, Texas Instruments Incorporated

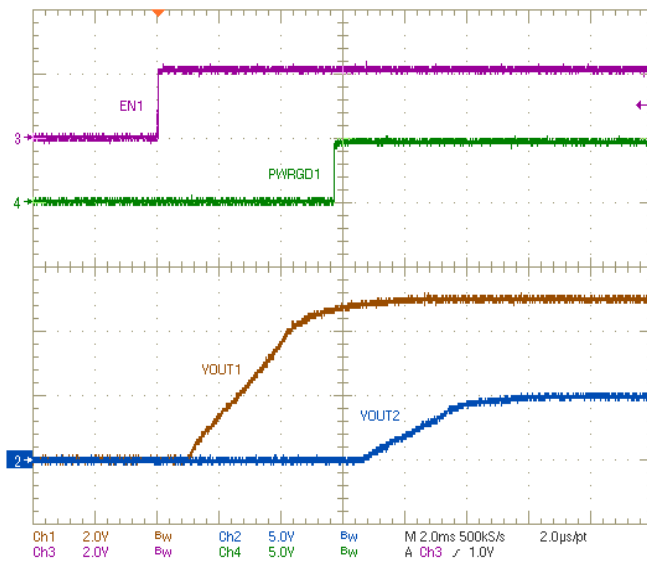
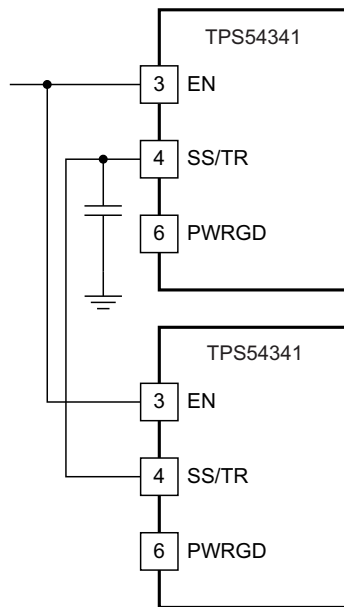

Figure 30. Sequential Startup Using EN and PWRGD

Figure 29. Schematic for Sequential Startup Sequence



Copyright © 2016, Texas Instruments Incorporated

Figure 31. Schematic for Ratiometric Startup Sequence

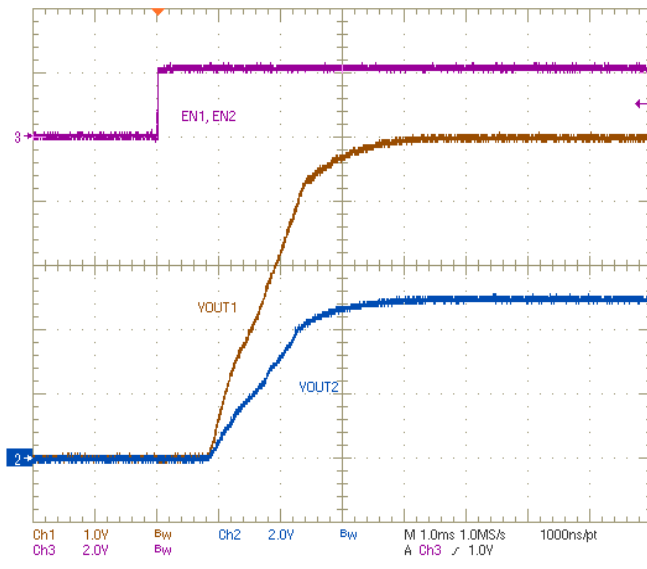
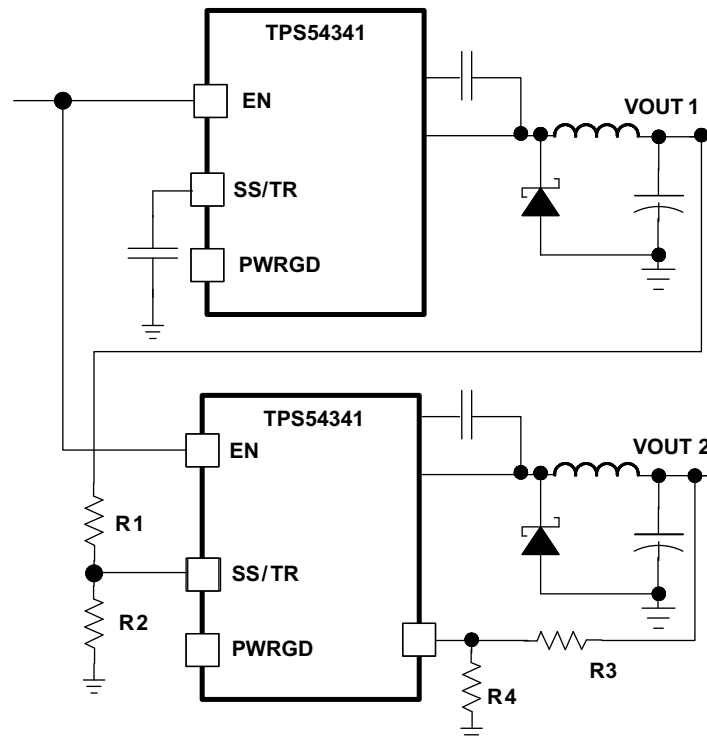

Figure 32. Ratiometric Startup Using Coupled SS/TR pins

Figure 31 shows a method for ratiometric start-up sequence by connecting the SS/TR pins together. The regulator outputs ramp up and reach regulation at the same time. When calculating the soft-start time the pullup current source must be doubled in Equation 5. Figure 32 shows the results of Figure 31.

Feature Description (continued)

Copyright © 2016, Texas Instruments Incorporated

Figure 33. Schematic for Ratiometric and Simultaneous Startup Sequence

Ratiometric and simultaneous power-supply sequencing is implemented by connecting the resistor network of R1 and R2 shown in Figure 33 to the output of the power supply that must be tracked or another voltage reference source. Using Equation 6 and Equation 7, calculate the tracking resistors to initiate the V_{OUT2} slightly before, after, or at the same time as V_{OUT1} . Equation 8 is the voltage difference between V_{OUT1} and V_{OUT2} at the 95% of nominal output regulation.

The ΔV variable is 0 V for simultaneous sequencing. To minimize the effect of the inherent SS/TR to FB offset ($V_{SSoffset}$) in the soft-start circuit and the offset created by the pullup-current source (I_{SS}) and tracking resistors, the $V_{SSoffset}$ and I_{SS} are included as variables in the equations.

To design a ratiometric start-up in which the V_{OUT2} voltage is slightly greater than the V_{OUT1} voltage when V_{OUT2} reaches regulation, use a negative number in Equation 6 through Equation 8 for ΔV . Equation 8 results in a positive number for applications which the V_{OUT2} is slightly lower than V_{OUT1} when V_{OUT2} regulation is achieved.

Because the SS/TR pin must be pulled below 54 mV before starting after an EN, UVLO, or thermal shutdown fault, careful selection of the tracking resistors is required to ensure the device restarts after a fault. The calculated R1 value from Equation 6 must be greater than the value calculated in Equation 9 to ensure the device recovers from a fault.

As the SS/TR voltage becomes more than 85% of the nominal reference voltage, the $V_{SSoffset}$ becomes larger as the soft-start circuits gradually hands-off the regulation reference to the internal voltage reference. The SS/TR pin voltage must be greater than 1.5 V for a complete handoff to the internal voltage reference.

$$R1 = \frac{V_{OUT2} + \Delta V}{V_{REF}} \times \frac{V_{SSoffset}}{I_{SS}} \quad (6)$$

$$R2 = \frac{V_{REF} \times R1}{V_{OUT2} + \Delta V - V_{REF}} \quad (7)$$

$$\Delta V = V_{OUT1} - V_{OUT2} \quad (8)$$

Feature Description (continued)

$$R1 > 2800 \times V_{OUT1} - 180 \times \Delta V \tag{9}$$

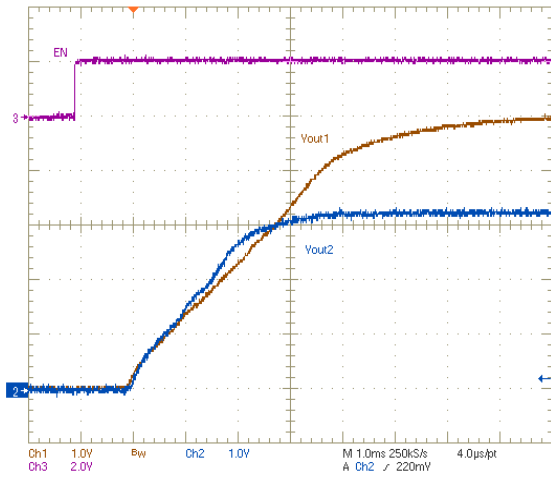

Figure 34. Ratiometric Startup With Tracking Resistors

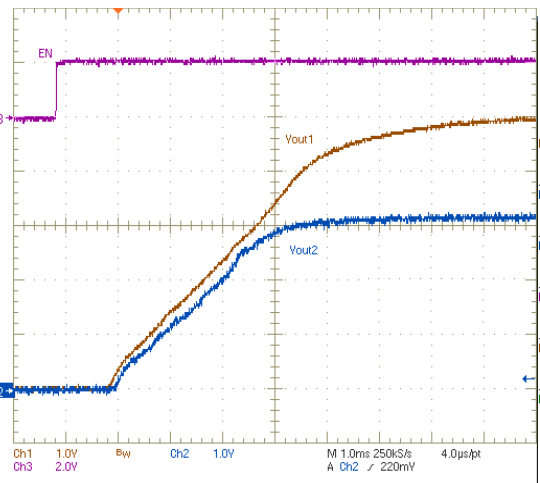

Figure 35. Ratiometric Startup With Tracking Resistors

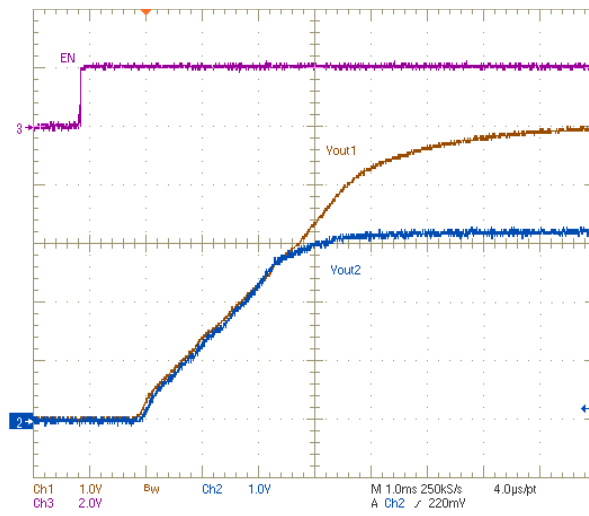

Figure 36. Simultaneous Startup With Tracking Resistor

7.3.9 Constant Switching Frequency and Timing Resistor (RT/CLK Pin)

The switching frequency of the TPS54341 device is adjustable over a wide range from 100 to 2500 kHz by placing a resistor between the RT/CLK pin and GND pin. The RT/CLK pin voltage is typically 0.5 V and must have a resistor to ground to set the switching frequency. To determine the timing resistance for a given switching frequency, use Equation 10 or Equation 11 or the curves in Figure 5 and Figure 6. To reduce the solution size, one typically sets the switching frequency as high as possible. Tradeoffs of the conversion efficiency, maximum input voltage, and minimum controllable on time must be considered. The minimum controllable on time is typically 135 ns which limits the maximum operating frequency in applications with high input-to-output step-down ratios. The maximum switching frequency is also limited by the frequency-foldback circuit. A more detailed discussion of the maximum switching frequency is provided in the next section.

$$RT \text{ (k}\Omega\text{)} = \frac{101756}{f_{SW} \text{ (kHz)}^{1.008}} \tag{10}$$

$$f_{SW} \text{ (kHz)} = \frac{92417}{RT \text{ (k}\Omega\text{)}^{0.991}} \tag{11}$$

Feature Description (continued)

7.3.10 Accurate Current Limit Operation and Maximum Switching Frequency

The TPS54341 device implements peak-current-mode control in which the COMP pin voltage controls the peak current of the high-side MOSFET. A signal proportional to the high-side switch current and the COMP pin voltage are compared each cycle. When the peak switch current intersects the COMP control voltage, the high-side switch turns off. During overcurrent conditions that pull the output voltage low, the error amplifier increases switch current by driving the COMP pin high. The error amplifier output clamps internally at a level which sets the peak switch current limit. The TPS54341 device provides an accurate current limit threshold with a typical current limit delay of 60 ns. With smaller inductor values, the delay results in a higher peak inductor current. The relationship between the inductor value and the peak inductor current is shown in [Figure 37](#).

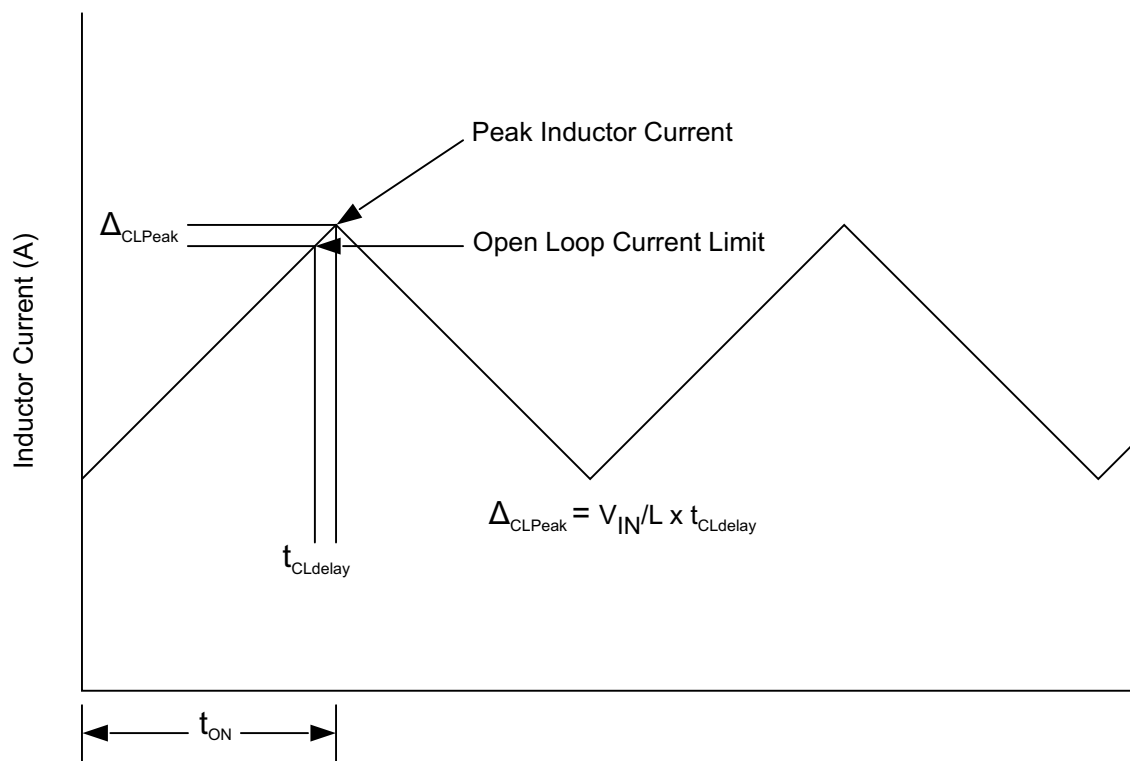

Figure 37. Current Limit Delay

To protect the converter in overload conditions at higher switching frequencies and input voltages, the TPS54341 device implements a frequency foldback. The oscillator frequency is divided by 1, 2, 4, and 8 as the FB pin voltage falls from 0.8 V to 0 V. The TPS54341 device uses a digital frequency foldback to enable synchronization to an external clock during normal startup and fault conditions. During short-circuit events, the inductor current can exceed the peak current-limit because of the high input voltage and the minimum controllable on time. When the output voltage is forced low by the shorted load, the inductor current decreases slowly during the switch off time. The frequency foldback effectively increases the off time by increasing the period of the switching cycle providing more time for the inductor current to ramp down.

With a maximum frequency-foldback ratio of 8, there is a maximum frequency at which frequency-foldback protection controls the inductor current. [Equation 13](#) calculates the maximum switching frequency at which the inductor current remains under control when V_{OUT} is forced to $V_{OUT(SC)}$. The selected operating frequency should not exceed the calculated value.

[Equation 12](#) calculates the maximum switching-frequency limitation set by the minimum controllable on time and the input-to-output step-down ratio. Setting the switching frequency above this value causes the regulator to skip switching pulses to achieve the low duty cycle required to regulate the output voltage at maximum input voltage.

Feature Description (continued)

$$f_{SW(max\ skip)} = \frac{1}{t_{ON}} \times \left(\frac{I_O \times R_{dc} + V_{OUT} + V_d}{V_{IN} - I_O \times R_{DS(on)} + V_d} \right) \quad (12)$$

$$f_{SW(shift)} = \frac{f_{DIV}}{t_{ON}} \times \left(\frac{I_{CL} \times R_{dc} + V_{OUT(sc)} + V_d}{V_{IN} - I_{CL} \times R_{DS(on)} + V_d} \right)$$

where

- I_O = output current
- I_{CL} = current limit
- R_{dc} = inductor resistance
- V_{IN} = maximum input voltage
- V_{OUT} = output voltage
- $V_{OUT(SC)}$ = output voltage during short
- V_d = diode voltage drop
- $R_{DS(on)}$ = switch on resistance
- t_{ON} = controllable on time
- f_{DIV} , frequency divide equals (1, 2, 4, or 8) (13)

7.3.11 Synchronization to RT/CLK Pin

The RT/CLK pin can receive a frequency synchronization signal from an external system clock. To implement this synchronization feature connect a square wave to the RT/CLK pin through either circuit network shown in [Figure 38](#). The square wave applied to the RT/CLK pin must switch lower than 0.5 V and higher than 2 V, and must have a pulsewidth greater than 15 ns. The synchronization frequency range is 160 to 2300 kHz. The rising edge of the SW synchronizes to the falling edge of RT/CLK pin signal. Design the external synchronization circuit such that the default-frequency set resistor connects from the RT/CLK pin to ground when the synchronization signal is off. When using a low-impedance signal source, the frequency-set resistor connects in parallel with an AC-coupling capacitor to a termination resistor (for example, 50 Ω) as shown in [Figure 38](#). The two resistors in the series provide the default frequency-setting resistance when the signal source is turned off. The sum of the resistance sets the switching frequency close to the external CLK frequency. AC-coupling the synchronization signal the synchronization signal through a 10-pF ceramic capacitor to RT/CLK pin is recommended.

The first time the RT/CLK pulls above the PLL threshold the TPS54341 device switches from the RT-resistor free-running frequency mode to the PLL-synchronized mode. The internal 0.5-V voltage source is removed and the RT/CLK pin becomes high impedance as the PLL begins to lock onto the external signal. The switching frequency can be higher or lower than the frequency set with the RT/CLK resistor. The device transitions from the resistor mode to the PLL mode and locks onto the external clock frequency within 78 μ s. During the transition from the PLL mode to the resistor-programmed mode, the switching frequency falls to 150 kHz and then increases or decreases to the resistor-programmed frequency when the 0.5-V bias voltage is reapplied to the RT/CLK resistor.

The switching frequency is divided by 8, 4, 2, and 1 as the FB pin voltage ramps from 0 to 0.8 V. The device implements a digital frequency foldback which enables synchronization to an external clock during normal startup and fault conditions. [Figure 39](#), [Figure 40](#) and [Figure 41](#) show the device synchronized to an external system clock in continuous conduction mode (CCM), discontinuous conduction (DCM), and pulse skip mode (Eco-Mode).

Feature Description (continued)

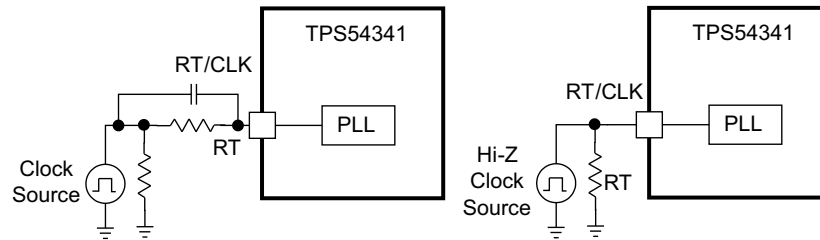

Copyright © 2016, Texas Instruments Incorporated

Figure 38. Synchronizing to a System Clock

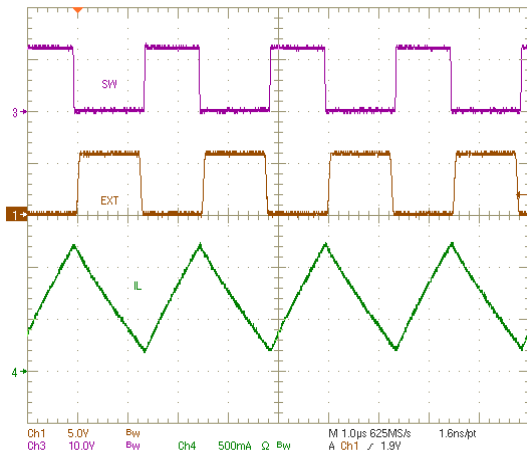

Figure 39. Plot of Synchronizing in CCM

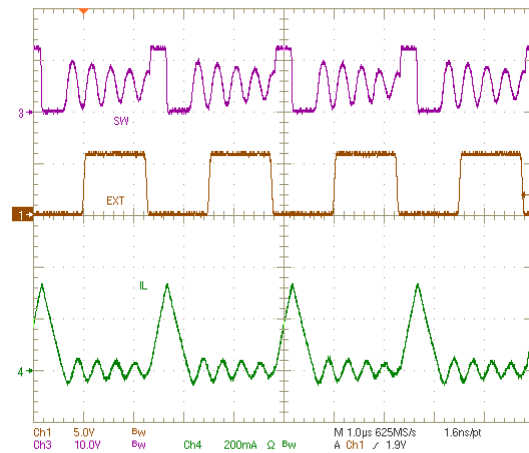

Figure 40. Plot of Synchronizing in DCM

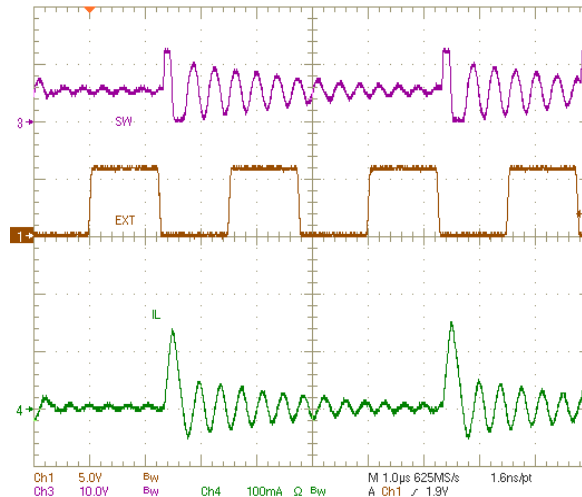

Figure 41. Plot of Synchronizing in Eco-mode

7.3.12 Power Good (PWRGD Pin)

The PWRGD pin is an open-drain output. Once the FB pin is between 93% and 106% of the internal voltage reference the PWRGD pin is de-asserted and the pin floats. A pull-up resistor of 1 kΩ to a voltage source that is 5.5 V or less is recommended. A higher pull-up resistance reduces the amount of current drawn from the pull up voltage source when the PWRGD pin is asserted low. A lower pullup resistance reduces the switching noise seen on the PWRGD signal. The PWRGD is in a defined state once the VIN input voltage is greater than 2 V but with reduced current sinking capability. The PWRGD will achieve full current sinking capability as VIN input voltage approaches 3 V.

Feature Description (continued)

The PWRGD pin is pulled low when the FB is lower than 90% or greater than 108% of the nominal internal reference voltage. Also, the PWRGD is pulled low, if the UVLO or thermal shutdown are asserted or the EN pin pulled low.

7.3.13 Overvoltage Protection

The TPS54341 device incorporates an output overvoltage-protection (OVP) circuit to minimize voltage overshoot when recovering from output fault conditions or strong unload transients in designs with low-output capacitance. For example, when the power-supply output is overloaded the error amplifier compares the actual output voltage to the internal reference voltage. If the FB pin voltage is lower than the internal reference voltage for a considerable time, the output of the error amplifier increases to a maximum voltage corresponding to the peak current-limit threshold. When the overload condition is removed, the regulator output rises and the error amplifier output transitions to the normal operating level. In some applications, the power-supply output voltage increases faster than the response of the error amplifier output resulting in an output overshoot.

The OVP feature minimizes output overshoot when using a low-value output capacitor by comparing the FB pin voltage to the rising OVP threshold which is nominally 108% of the internal voltage reference. If the FB pin voltage is greater than the rising OVP threshold, the high-side MOSFET disables immediately to minimize output overshoot. When the FB voltage drops below the falling OVP threshold which is nominally 106% of the internal voltage reference, the high-side MOSFET resumes normal operation.

7.3.14 Thermal Shutdown

The TPS54341 device provides an internal thermal shutdown to protect the device when the junction temperature exceeds 176°C. The high-side MOSFET stops switching when the junction temperature exceeds the thermal trip threshold. Once the die temperature falls below 164°C, the device reinitiates the power-up sequence controlled by discharging the SS/TR pin.

7.3.15 Small-Signal Model for Loop Response

Figure 42 shows a simplified equivalent model for the TPS54341 control loop which is simulated to check the frequency response and dynamic load response. The error amplifier is a transconductance amplifier with a $g_{m_{EA}}$ of 350 $\mu\text{A/V}$. The error amplifier is modeled using an ideal voltage-controlled current source. The resistor R_O and capacitor C_O model the open-loop gain and frequency response of the amplifier. The 1-mV AC-voltage source between the nodes a and b effectively breaks the control loop for the frequency response measurements. Plotting c/a provides the small signal response of the frequency compensation. Plotting a/b provides the small signal response of the overall loop. The dynamic loop response is evaluated by replacing R_L with a current source with the appropriate load step amplitude and step rate in a time domain analysis. This equivalent model is only valid for CCM operation.

Feature Description (continued)

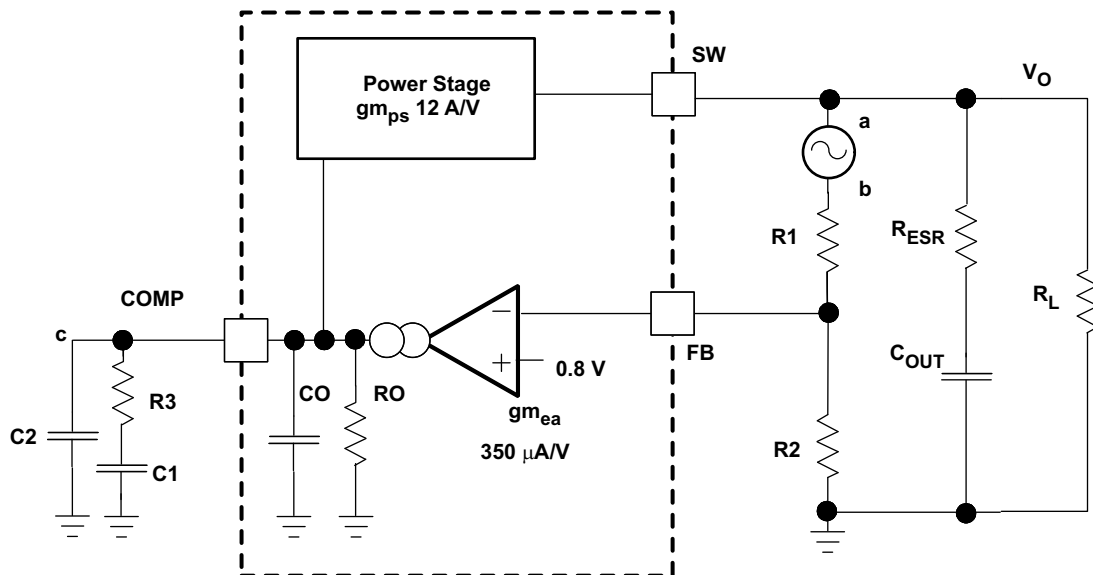

Figure 42. Small-Signal Model for Loop Response

7.3.16 Simple Small-Signal Model for Peak-Current-Mode Control

Figure 43 describes a simple small-signal model used to design the frequency compensation. The TPS54341 power stage is approximated by a voltage-controlled current source (duty-cycle modulator) supplying current to the output capacitor and load resistor. The control to output transfer function is shown in Equation 14 and consists of a DC gain, one dominant pole, and one equivalent-series-resistor (ESR) zero. The quotient of the change in switch current and the change in COMP pin voltage (node c in Figure 42) is the power stage transconductance, gm_{PS} . The gm_{PS} for the TPS54341 device is 16 A/V. The low-frequency gain of the power stage is the product of the transconductance and the load resistance as shown in Equation 15.

As the load current increases and decreases, the low-frequency gain decreases and increases, respectively. This variation with the load seems problematic at first glance, but fortunately the dominant pole moves with the load current (see Equation 16). The combined effect is highlighted by the dashed line in the right half of Figure 43. As the load current decreases, the gain increases and the pole frequency lowers, keeping the 0-dB crossover frequency the same with varying load conditions. The type of output capacitor chosen determines whether the ESR zero has a profound effect on the frequency compensation design. Using high-ESR aluminum-electrolytic capacitors can reduce the number frequency compensation components required to stabilize the overall loop because the phase margin increases by the ESR zero of the output capacitor (see Functional Block Diagram).

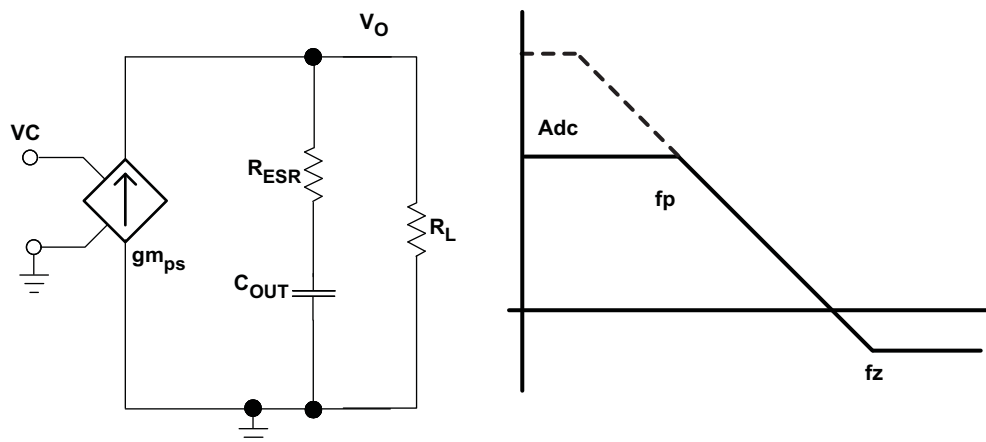

Figure 43. Simple Small-Signal Model and Frequency Response for Peak-Current-Mode Control

Feature Description (continued)

$$\frac{V_{OUT}}{VC} = A_{dc} \times \frac{\left(1 + \frac{s}{2\pi \times f_Z}\right)}{\left(1 + \frac{s}{2\pi \times f_P}\right)} \tag{14}$$

$$A_{dc} = g_{m_{ps}} \times R_L \tag{15}$$

$$f_P = \frac{1}{C_{OUT} \times R_L \times 2\pi} \tag{16}$$

$$f_Z = \frac{1}{C_{OUT} \times R_{ESR} \times 2\pi} \tag{17}$$

7.3.17 Small Signal Model for Frequency Compensation

The TPS54341 device uses a transconductance amplifier for the error amplifier and supports three of the commonly-used frequency compensation circuits. Compensation circuits Type 2A, Type 2B, and Type 1 are shown in Figure 44. Type 2 circuits are typically implemented in high bandwidth power-supply designs using low-ESR output capacitors. The Type 1 circuit is used with power-supply designs with high-ESR aluminum-electrolytic or tantalum capacitors. Equation 18 and Equation 19 relate the frequency response of the amplifier to the small signal model in Figure 44. The open-loop gain and bandwidth are modeled using the R_O and C_O shown in Figure 44. See the *Application Information* section for a design example using a Type 2A network with a low-ESR output capacitor.

Equation 18 through Equation 27 are provided as a reference. An alternative is to use WEBENCH software tools to create a design based on the power-supply requirements (go to www.ti.com/WEBENCH for more information).

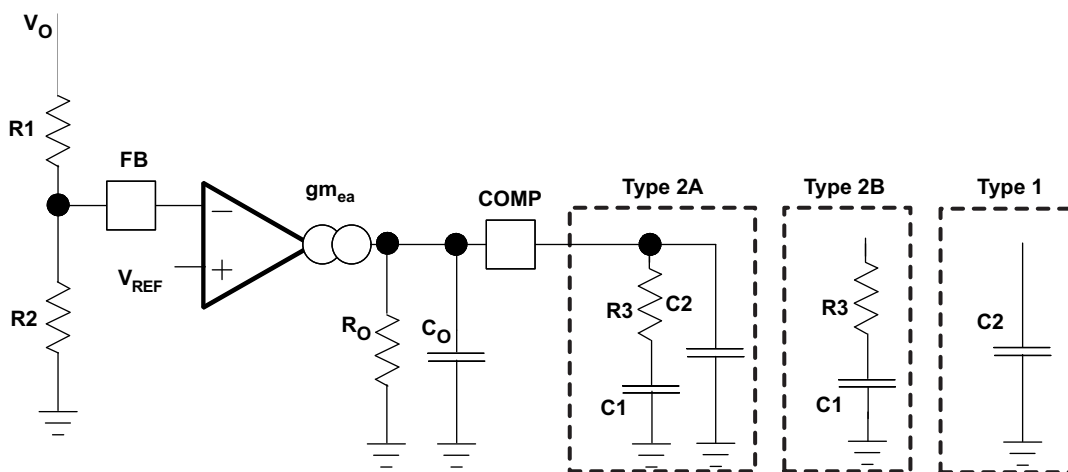
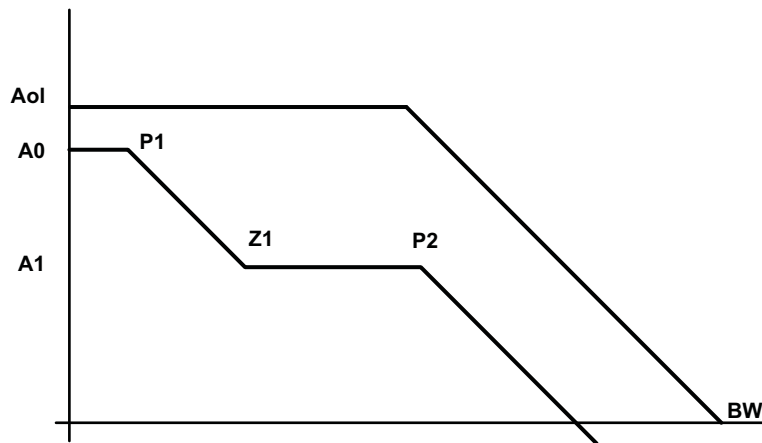

Figure 44. Types of Frequency Compensation

Feature Description (continued)

Figure 45. Frequency Response of the Type 2A and Type 2B Frequency Compensation

$$R_O = \frac{A_{ol}(V/V)}{g_{m_{ea}}} \quad (18)$$

$$C_O = \frac{g_{m_{ea}}}{2\pi \times BW \text{ (Hz)}} \quad (19)$$

$$EA = A_0 \times \frac{\left(1 + \frac{s}{2\pi \times f_{Z1}}\right)}{\left(1 + \frac{s}{2\pi \times f_{P1}}\right) \times \left(1 + \frac{s}{2\pi \times f_{P2}}\right)} \quad (20)$$

$$A_0 = g_{m_{ea}} \times R_O \times \frac{R_2}{R_1 + R_2} \quad (21)$$

$$A_1 = g_{m_{ea}} \times R_O \parallel R_3 \times \frac{R_2}{R_1 + R_2} \quad (22)$$

$$P_1 = \frac{1}{2\pi \times R_O \times C_1} \quad (23)$$

$$Z_1 = \frac{1}{2\pi \times R_3 \times C_1} \quad (24)$$

$$P_2 = \frac{1}{2\pi \times R_3 \parallel R_O \times (C_2 + C_O)} \text{ Type 2A} \quad (25)$$

$$P_2 = \frac{1}{2\pi \times R_3 \parallel R_O \times C_O} \text{ Type 2B} \quad (26)$$

$$P_2 = \frac{1}{2\pi \times R_O \times (C_2 + C_O)} \text{ Type 1} \quad (27)$$

7.4 Device Functional Modes

7.4.1 Pulse Skip Eco-mode

The TPS54341 device operates in a pulse-skipping Eco-mode at light load currents to improve efficiency by reducing switching and gate drive losses. If the output voltage is within regulation and the peak switch current at the end of any switching cycle is below the pulse skipping current threshold, the device enters Eco-mode. The pulse-skipping current threshold is the peak switch-current level corresponding to a nominal COMP voltage of 600 mV.

When in Eco-mode, the COMP pin voltage is clamped at 600 mV and the high-side MOSFET is inhibited. Because the device is not switching, the output voltage begins to decay. The voltage-control loop responds to the falling output voltage by increasing the COMP pin voltage. The high-side MOSFET enables and switching resumes when the error amplifier lifts COMP above the pulse skipping threshold. The output voltage recovers to the regulated value, and COMP eventually falls below the Eco-mode pulse skipping threshold at which time the device again enters Eco-mode. The internal PLL remains operational when in Eco-mode. When operating at light load currents in Eco-mode, the switching transitions occur synchronously with the external clock signal.

During Eco-mode operation, the TPS54341 device senses and controls peak switch current, not the average load current. Therefore the load current at which the device enters Eco-mode is dependent on the output inductor value. The circuit in [Figure 46](#) enters Eco-mode at 30-mA output current. As the load current approaches zero, the device enters a pulse-skip mode during which it draws only 152- μ A input quiescent current.

8 Application and Implementation

NOTE

Information in the following applications sections is not part of the TI component specification, and TI does not warrant its accuracy or completeness. TI's customers are responsible for determining suitability of components for their purposes. Customers should validate and test their design implementation to confirm system functionality.

8.1 Application Information

The TPS54341 is a 42 V, 3.5 A, step down regulator with an integrated high side MOSFET. Ideal applications are: 12 V, 24 V Industrial, Automotive and Communications Power Systems.

8.2 Typical Application

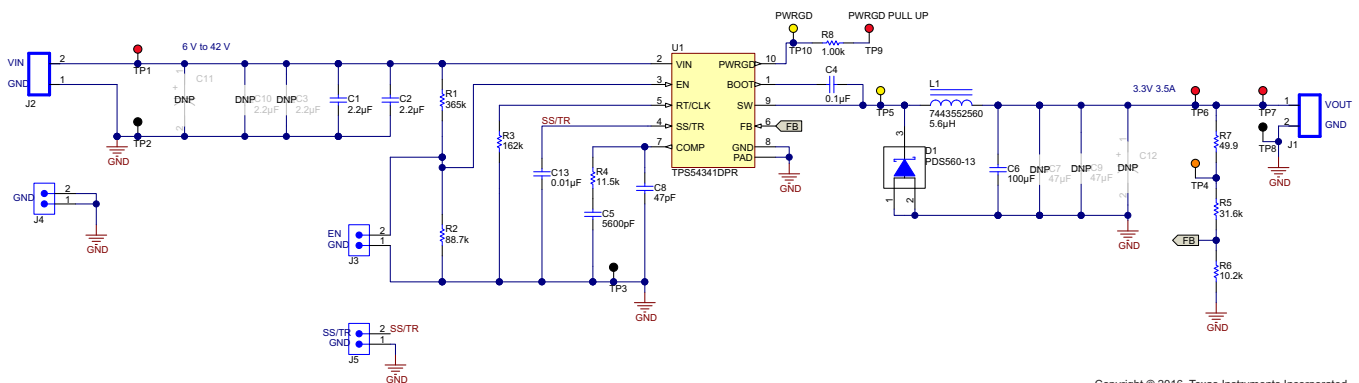

Copyright © 2016, Texas Instruments Incorporated

Figure 46. 3.3-V Output TPS54341 Design Example

8.2.1 Design Requirements

This section illustrates the design of a high frequency switching regulator using ceramic output capacitors. A few parameters must be known in order to start the design process. These requirements are typically determined at the system level. The necessary calculations can be done using WEBENCH or the excel spreadsheet (SLVC452) located on the product. This design starts with the parameters in Table 1.

Typical Application (continued)

Table 1. Design Parameters

PARAMETER	VALUE
Output voltage	3.3 V
Transient response 0.875 A to 2.625 A load step	$\Delta V_{OUT} = 4\%$
Maximum output current	3.5 A
Input voltage	12 V nominal 6 V to 42 V
Output voltage ripple	0.5% of V_{OUT}
Start input voltage (rising VIN)	5.75 V
Stop input voltage (falling VIN)	4.5 V

8.2.2 Detailed Design Procedure

8.2.2.1 Selecting the Switching Frequency

The first step is to choose a switching frequency for the regulator. Typically, the designer uses the highest switching frequency possible because this produces the smallest solution size. High switching frequency allows for lower value inductors and smaller output capacitors compared to a power supply that switches at a lower frequency. The switching frequency that can be selected is limited by the minimum on-time of the internal power switch, the input voltage, the output voltage and the frequency-foldback protection.

[Equation 12](#) and [Equation 13](#) must be used to calculate the upper limit of the switching frequency for the regulator. Choose the lower value result from the two equations. Switching frequencies higher than these values results in pulse skipping or the lack of overcurrent protection during a short circuit.

The typical minimum on time, t_{onmin} , is 135 ns for the TPS54341 device. For this example, the output voltage is 3.3 V and the maximum input voltage is 42 V, which allows for a maximum switch frequency up to 712 kHz to avoid pulse skipping from [Equation 12](#). To ensure overcurrent runaway is not a concern during short circuits use [Equation 13](#) to determine the maximum switching frequency for frequency foldback protection. With a maximum input voltage of 42 V, assuming a diode voltage of 0.7 V, inductor resistance of 21 m Ω , switch resistance of 87 m Ω , a current-limit value of 4.7 A and short circuit output voltage of 0.1 V, the maximum switching frequency is 1260 kHz.

For this design, a lower switching frequency of 600 kHz is chosen to operate comfortably below the calculated maximums. To determine the timing resistance for a given switching frequency, use [Equation 10](#) or the curve in [Figure 6](#). The switching frequency is set by resistor R_3 shown in [Figure 46](#). For 600 kHz operation, the closest standard value resistor is 162 k Ω .

$$f_{SW(maxskip)} = \frac{1}{135ns} \times \left(\frac{3.5 A \times 21 m\Omega + 3.3 V + 0.7 V}{42 V - 3.5 A \times 87 m\Omega + 0.7 V} \right) = 712 \text{ kHz} \quad (28)$$

$$f_{SW(shift)} = \frac{8}{135 ns} \times \left(\frac{4.7 A \times 21 m\Omega + 0.1 V + 0.7 V}{42 V - 4.7 A \times 87 m\Omega + 0.7 V} \right) = 1260 \text{ kHz} \quad (29)$$

$$RT (k\Omega) = \frac{101756}{600 (kHz)^{1.008}} = 161 \text{ k}\Omega \quad (30)$$

8.2.2.2 Output Inductor Selection (L_O)

To calculate the minimum value of the output inductor, use [Equation 31](#).

K_{IND} is a ratio that represents the amount of inductor ripple current relative to the maximum output current. The inductor ripple current is filtered by the output capacitor. Therefore, choosing high inductor ripple currents impacts the selection of the output capacitor because the output capacitor must have a ripple current rating equal to or greater than the inductor ripple current. In general, the inductor ripple value is at the discretion of the designer, however, the following guidelines may be used.

For designs using low ESR output capacitors such as ceramics, a value as high as $K_{IND} = 0.3$ may be desirable. When using higher ESR output capacitors, $K_{IND} = 0.2$ yields better results. Because the inductor ripple current is part of the current mode PWM control system, the inductor ripple current should always be greater than 150 mA for stable PWM operation. In a wide input voltage regulator, it is best to choose relatively large inductor ripple current. This provides sufficient ripple current with the input voltage at the minimum.

For this design example, $K_{IND} = 0.3$ and the minimum inductor value is calculated to be 4.8 μH . The nearest standard value is 5.6 μH . It is important that the RMS current and saturation current ratings of the inductor not be exceeded. The RMS and peak inductor current can be found from [Equation 33](#) and [Equation 34](#). For this design, the RMS inductor current is 3.5 A and the peak inductor current is 3.95 A. The chosen inductor is a WE 7443552560, which has a saturation current rating of 7.5 A and an RMS current rating of 6.7 A.

As the equation set demonstrates, lower ripple currents will reduce the output voltage ripple of the regulator but will require a larger value of inductance. Selecting higher ripple currents will increase the output voltage ripple of the regulator but allow for a lower inductance value.

The current flowing through the inductor is the inductor ripple current plus the output current. During power up, faults or transient load conditions, the inductor current can increase above the peak inductor current level calculated above. In transient conditions, the inductor current can increase up to the switch current limit of the device. For this reason, the most conservative design approach is to choose an inductor with a saturation current rating equal to or greater than the switch current limit of the TPS54341 device which is nominally 5.5 A.

$$L_{O(\min)} = \frac{V_{IN(\max)} - V_{OUT}}{I_{OUT} \times K_{IND}} \times \frac{V_{OUT}}{V_{IN(\max)} \times f_{SW}} = \frac{42 \text{ V} - 3.3 \text{ V}}{3.5 \text{ A} \times 0.3} \times \frac{3.3 \text{ V}}{42 \text{ V} \times 600 \text{ kHz}} = 4.8 \mu\text{H} \quad (31)$$

$$I_{RIPPLE} = \frac{V_{OUT} \times (V_{IN(\max)} - V_{OUT})}{V_{IN(\max)} \times L_O \times f_{SW}} = \frac{3.3 \text{ V} \times (42 \text{ V} - 3.3 \text{ V})}{42 \text{ V} \times 5.6 \mu\text{H} \times 600 \text{ kHz}} = 0.905 \text{ A} \quad (32)$$

$$I_{L(\text{rms})} = \sqrt{I_{OUT}^2 + \frac{1}{12} \times \left(\frac{V_{OUT} \times (V_{IN(\max)} - V_{OUT})}{V_{IN(\max)} \times L_O \times f_{SW}} \right)^2} = \sqrt{(3.5 \text{ A})^2 + \frac{1}{12} \times \left(\frac{3.3 \text{ V} \times (42 \text{ V} - 3.3 \text{ V})}{42 \text{ V} \times 5.6 \mu\text{H} \times 600 \text{ kHz}} \right)^2} = 3.5 \text{ A} \quad (33)$$

$$I_{L(\text{peak})} = I_{OUT} + \frac{I_{RIPPLE}}{2} = 3.5 \text{ A} + \frac{0.905 \text{ A}}{2} = 3.95 \text{ A} \quad (34)$$

8.2.2.3 Output Capacitor

There are three primary considerations for selecting the value of the output capacitor. The output capacitor determines the modulator pole, the output voltage ripple, and how the regulator responds to a large change in load current. The output capacitance needs to be selected based on the most stringent of these three criteria.

The desired response to a large change in the load current is the first criteria. The output capacitor needs to supply the increased load current until the regulator responds to the load step. The regulator does not respond immediately to a large, fast increase in the load current such as transitioning from no load to a full load. The regulator usually needs two or more clock cycles for the control loop to sense the change in output voltage and adjust the peak switch current in response to the higher load. The output capacitance must be large enough to supply the difference in current for two clock cycles to maintain the output voltage within the specified range. [Equation 35](#) shows the minimum output capacitance necessary, where ΔI_{OUT} is the change in output current, f_{sw} is the regulators switching frequency and ΔV_{OUT} is the allowable change in the output voltage. For this example, the transient load response is specified as a 4% change in V_{OUT} for a load step from 0.875 A to 2.625 A. Therefore, ΔI_{OUT} is 2.625 A – 0.875 A = 1.75 A and $\Delta V_{OUT} = 0.04 \times 3.3 = 0.13 \text{ V}$. Using these numbers gives a minimum capacitance of 44.9 μF . This value does not take the ESR of the output capacitor into account in the output voltage change. For ceramic capacitors, the ESR is usually small enough to be ignored. Aluminum electrolytic and tantalum capacitors have higher ESR that must be included in load step calculations.

The output capacitor must also be sized to absorb energy stored in the inductor when transitioning from a high to low load current. The catch diode of the regulator can not sink current so energy stored in the inductor can produce an output voltage overshoot when the load current rapidly decreases. A typical load step response is shown in [Figure 49](#). The excess energy absorbed in the output capacitor will increase the voltage on the capacitor. The capacitor must be sized to maintain the desired output voltage during these transient periods.

Equation 36 calculates the minimum capacitance required to keep the output voltage overshoot to a desired value, where L_O is the value of the inductor, I_{OH} is the output current under heavy load, I_{OL} is the output under light load, V_f is the peak output voltage, and V_i is the initial voltage. For this example, the worst case load step will be from 2.625 A to 0.875 A. The output voltage increases during this load transition and the stated maximum in our specification is 4 % of the output voltage. This makes $V_f = 1.04 \times 3.3 = 3.432$. V_i is the initial capacitor voltage which is the nominal output voltage of 3.3 V. Using these numbers in **Equation 36** yields a minimum capacitance of 38.6 μF .

Equation 37 calculates the minimum output capacitance needed to meet the output voltage ripple specification, where f_{sw} is the switching frequency, $V_{ORIPPLE}$ is the maximum allowable output voltage ripple, and I_{RIPPLE} is the inductor ripple current. **Equation 37** yields 11.4 μF .

Equation 38 calculates the maximum ESR an output capacitor can have to meet the output voltage ripple specification. **Equation 38** indicates the ESR should be less than 18 $\text{m}\Omega$.

The most stringent criteria for the output capacitor is 44.9 μF required to maintain the output voltage within regulation tolerance during a load transient.

Capacitance de-ratings for aging, temperature and dc bias increases this minimum value. For this example, a 100- μF ceramic capacitor with 5 $\text{m}\Omega$ of ESR is used. The derated capacitance is 70 μF , well above the minimum required capacitance of 44.9 μF .

Capacitors are generally rated for a maximum ripple current that can be filtered without degrading capacitor reliability. Some capacitor data sheets specify the Root Mean Square (RMS) value of the maximum ripple current. **Equation 39** can be used to calculate the RMS ripple current that the output capacitor must support. For this example, **Equation 39** yields 261 mA.

$$C_{OUT} > \frac{2 \times \Delta I_{OUT}}{f_{SW} \times \Delta V_{OUT}} = \frac{2 \times 1.75 \text{ A}}{600 \text{ kHz} \times 0.13 \text{ V}} = 44.9 \mu\text{F} \quad (35)$$

$$C_{OUT} > L_O \times \frac{(I_{OH})^2 - (I_{OL})^2}{(V_f)^2 - (V_i)^2} = 5.6 \mu\text{H} \times \frac{(2.625 \text{ A}^2 - 0.875 \text{ A}^2)}{(3.432 \text{ V}^2 - 3.3 \text{ V}^2)} = 38.6 \mu\text{F} \quad (36)$$

$$C_{OUT} > \frac{1}{8 \times f_{SW}} \times \frac{1}{\left(\frac{V_{ORIPPLE}}{I_{RIPPLE}}\right)} = \frac{1}{8 \times 600 \text{ kHz}} \times \frac{1}{\left(\frac{16.5 \text{ mV}}{0.905 \text{ A}}\right)} = 11.4 \mu\text{F} \quad (37)$$

$$R_{ESR} < \frac{V_{ORIPPLE}}{I_{RIPPLE}} = \frac{16.5 \text{ mV}}{0.905 \text{ A}} = 18 \text{ m}\Omega \quad (38)$$

$$I_{COUT(rms)} = \frac{V_{OUT} \times (V_{IN(max)} - V_{OUT})}{\sqrt{12} \times V_{IN(max)} \times L_O \times f_{SW}} = \frac{3.3 \text{ V} \times (42 \text{ V} - 3.3 \text{ V})}{\sqrt{12} \times 42 \text{ V} \times 5.6 \mu\text{H} \times 600 \text{ kHz}} = 261 \text{ mA} \quad (39)$$

8.2.2.4 Catch Diode

The TPS54341 device requires an external catch diode between the SW pin and GND. The selected diode must have a reverse voltage rating equal to or greater than $V_{IN(max)}$. The peak current rating of the diode must be greater than the maximum inductor current. Schottky diodes are typically a good choice for the catch diode due to their low forward voltage. The lower the forward voltage of the diode, the higher the efficiency of the regulator.

Typically, diodes with higher voltage and current ratings have higher forward voltages. A diode with a minimum of 42 V reverse voltage is preferred to allow input voltage transients up to the rated voltage of the TPS54341 device.

For the example design, the PDS560 Schottky diode is selected for its lower forward voltage and good thermal characteristics compared to smaller devices. The typical forward voltage of the PDS560 is 0.55 V at 3.5 A.

The diode must also be selected with an appropriate power rating. The diode conducts the output current during the off-time of the internal power switch. The off-time of the internal switch is a function of the maximum input voltage, the output voltage, and the switching frequency. The output current during the off-time is multiplied by the forward voltage of the diode to calculate the instantaneous conduction losses of the diode. At higher switching frequencies, the AC losses of the diode must be taken into account. The AC losses of the diode are due to the charging and discharging of the junction capacitance and reverse recovery charge. Equation 40 is used to calculate the total power dissipation, including conduction losses and AC losses of the diode.

The PDS560 diode has a junction capacitance of 90 pF at 42 V input voltage. Using Equation 40, the total loss in the diode is 2.27 W.

If the power supply spends a significant amount of time at light load currents or in sleep mode, consider using a diode which has a low leakage current and slightly higher forward voltage drop.

$$P_D = \frac{(V_{IN(max)} - V_{OUT}) \times I_{OUT} \times V_{fd}}{V_{IN(max)}} + \frac{C_j \times f_{SW} \times (V_{IN} + V_{fd})^2}{2} =$$

$$\frac{(42 \text{ V} - 3.3 \text{ V}) \times 3.5 \text{ A} \times 0.55 \text{ V}}{42 \text{ V}} + \frac{90 \text{ pF} \times 600 \text{ kHz} \times (42 \text{ V} + 0.55 \text{ V})^2}{2} = 2.27 \text{ W} \quad (40)$$

8.2.2.5 Input Capacitor

The TPS54341 device requires a high-quality ceramic-type X5R or X7R input-decoupling capacitor with at least 3 μF of effective capacitance. Some applications will benefit from additional bulk capacitance. The effective capacitance includes any loss of capacitance due to dc bias effects. The voltage rating of the input capacitor must be greater than the maximum input voltage. The capacitor must also have a ripple current rating greater than the maximum input current ripple of the TPS54341 device. The input ripple current can be calculated using Equation 41.

The value of a ceramic capacitor varies significantly with temperature and the dc bias applied to the capacitor. The capacitance variations due to temperature can be minimized by selecting a dielectric material that is more stable over temperature. X5R and X7R ceramic dielectrics are usually selected for switching regulator capacitors because they have a high capacitance to volume ratio and are fairly stable over temperature. The input capacitor must also be selected with consideration for the dc bias. The effective value of a capacitor decreases as the dc bias across a capacitor increases.

For this example design, a ceramic capacitor with at least a 42 V voltage rating is required to support the maximum input voltage. Common standard ceramic capacitor voltage ratings include 4 V, 6.3 V, 10 V, 16 V, 25 V, 50 V, or 100 V. For this example, two 2.2- μF 100-V capacitors in parallel are used. Table 2 shows several choices of high voltage capacitors.

The input capacitance value determines the input ripple voltage of the regulator. The input voltage ripple can be calculated using Equation 41. Using the design example values, $I_{OUT} = 3.5 \text{ A}$, $C_{IN} = 4.4 \mu\text{F}$, $f_{SW} = 600 \text{ kHz}$, yields an input voltage ripple of 331 mV and a rms input ripple current of 1.74 A as seen in Equation 42.

$$I_{CI(rms)} = I_{OUT} \times \sqrt{\frac{V_{OUT}}{V_{IN(min)}} \times \frac{(V_{IN(min)} - V_{OUT})}{V_{IN(min)}}} = 3.5 \text{ A} \times \sqrt{\frac{3.3 \text{ V}}{6 \text{ V}} \times \frac{(6 \text{ V} - 3.3 \text{ V})}{6 \text{ V}}} = 1.74 \text{ A} \quad (41)$$

$$\Delta V_{IN} = \frac{I_{OUT} \times 0.25}{C_{IN} \times f_{SW}} = \frac{3.5 \text{ A} \times 0.25}{4.4 \mu\text{F} \times 600 \text{ kHz}} = 331 \text{ mV} \quad (42)$$

Table 2. Capacitor Types

VENDOR	VALUE (μF)	EIA SIZE	VOLTAGE (V)	DIELECTRIC	COMMENTS		
Murata	1 to 2.2	1210	100	X7R	GRM32 series		
	1 to 4.7		50				
	1	1206	100		GRM31 series		
	1 to 2.2		50				
Vishay	1 to 1.8	2220	50		VJ X7R series		
	1 to 1.2		100				
	1 to 3.9	2225	50				
	1 to 1.8		100				
TDK	1 to 2.2	1812	100			C series C4532	
	1.5 to 6.8		50				
	1 to 2.2	1210	100				C series C3225
	1 to 3.3		50				
AVX	1 to 4.7	1210	50	X7R dielectric series			
	1		100				
	1 to 4.7	1812	50				
	1 to 2.2		100				

8.2.2.6 Slow-Start Capacitor

The slow-start capacitor determines the minimum amount of time it will take for the output voltage to reach its nominal programmed value during power up. This is useful if a load requires a controlled voltage slew rate. This is also used if the output capacitance is large and would require large amounts of current to quickly charge the capacitor to the output voltage level. The large currents necessary to charge the capacitor may make the TPS54341 device reach the current limit or excessive current draw from the input power supply may cause the input voltage rail to sag. Limiting the output voltage slew rate solves both of these problems.

The slow-start time must be long enough to allow the regulator to charge the output capacitor up to the output voltage without drawing excessive current. Equation 43 can be used to find the minimum slow-start time, T_{SS} , necessary to charge the output capacitor, C_{OUT} , from 10% to 90% of the output voltage, V_{OUT} , with an average slow-start current of I_{SSavg} . In the example, to charge the effective output capacitance of 70 μF up to 3.3 V with an average current of 1 A requires a 0.2-ms slow-start time.

Once the slow-start time is known, the slow-start capacitor value can be calculated using Equation 43. For the example circuit, the slow-start time is not too critical because the output capacitor value is 100 μF which does not require much current to charge to 3.3 V. The example circuit has the slow-start time set to an arbitrary value of 3.5 ms which requires a 9.3-nF slow-start capacitor calculated by Equation 44. For this design, the next larger standard value of 10 nF is used.

$$T_{SS} > \frac{C_{OUT} \times V_{OUT} \times 0.8}{I_{SSavg}} \quad (43)$$

$$C_{SS} \text{ (nF)} = \frac{T_{SS} \text{ (ms)} \times I_{SS} \text{ (μA)}}{V_{REF} \text{ (V)} \times 0.8} = 3.5 \text{ ms} \times \frac{1.7 \text{ μA}}{(0.8 \text{ V} \times 0.8)} = 9.3 \text{ nF} \quad (44)$$

8.2.2.7 Bootstrap Capacitor Selection

A 0.1-μF ceramic capacitor must be connected between the BOOT and SW pins for proper operation. A ceramic capacitor with X5R or better grade dielectric is recommended. The capacitor must have a 10 V or higher voltage rating.

8.2.2.8 Undervoltage Lockout Set Point

The Undervoltage Lockout (UVLO) can be adjusted using an external voltage divider on the EN pin of the TPS54341 device. The UVLO has two thresholds, one for power up when the input voltage is rising and one for power down or brown outs when the input voltage is falling. For the example design, the supply should turn on and start switching once the input voltage increases above 5.75 V (UVLO start). After the regulator starts switching, it should continue to do so until the input voltage falls below 4.5 V (UVLO stop).

Programmable UVLO threshold voltages are set using the resistor divider of R_{UVLO1} and R_{UVLO2} between VIN and ground connected to the EN pin. Equation 3 and Equation 4 calculate the resistance values necessary. For the example application, a 365 k Ω between Vin and EN (R_{UVLO1}) and a 88.7 k Ω between EN and ground (R_{UVLO2}) are required to produce the 8-V and 6.25-V start and stop voltages as seen in Equation 45 and Equation 46.

$$R_{UVLO1} = \frac{V_{START} - V_{STOP}}{I_{HYS}} = \frac{5.75 \text{ V} - 4.5 \text{ V}}{3.4 \mu\text{A}} = 368 \text{ k}\Omega \quad (45)$$

$$R_{UVLO2} = \frac{V_{ENA}}{\frac{V_{START} - V_{ENA}}{R_{UVLO1}} + I_1} = \frac{1.2 \text{ V}}{\frac{5.75 \text{ V} - 1.2 \text{ V}}{365 \text{ k}\Omega} + 1.2 \mu\text{A}} = 87.8 \text{ k}\Omega \quad (46)$$

8.2.2.9 Output Voltage and Feedback Resistors Selection

The voltage divider of R5 and R6 sets the output voltage. For the example design, 10.2 k Ω was selected for R6. Using Equation 2, R5 is calculated as 31.9 k Ω . The nearest standard 1% resistor is 31.6 k Ω . Due to the input current of the FB pin, the current flowing through the feedback network should be greater than 1 μA to maintain the output voltage accuracy. This requirement is satisfied if the value of R6 is less than 800 k Ω . Choosing higher resistor values decreases quiescent current and improves efficiency at low output currents but may also introduce noise immunity problems (see Equation 47).

$$R_{HS} = R_{LS} \times \frac{V_{OUT} - 0.8 \text{ V}}{0.8 \text{ V}} = 10.2 \text{ k}\Omega \times \left(\frac{3.3 \text{ V} - 0.8 \text{ V}}{0.8 \text{ V}} \right) = 31.9 \text{ k}\Omega \quad (47)$$

8.2.2.10 Compensation

There are several methods to design compensation for DC-DC regulators. The method presented here is easy to calculate and ignores the effects of the slope compensation that is internal to the device. Because the slope compensation is ignored, the actual crossover frequency will be lower than the crossover frequency used in the calculations. This method assumes the crossover frequency is between the modulator pole and the ESR zero and the ESR zero is at least ten-times greater the modulator pole.

To get started, the modulator pole, $f_{p(mod)}$, and the ESR zero, f_{z1} must be calculated using Equation 48 and Equation 49. For C_{OUT} , use a derated value of 70 μF . Use equations Equation 50 and Equation 51 to estimate a starting point for the crossover frequency, f_{co} . For the example design, $f_{p(mod)}$ is 2411 Hz and $f_{z(mod)}$ is 455 kHz. Equation 49 is the geometric mean of the modulator pole and the ESR zero and Equation 51 is the mean of modulator pole and the switching frequency. Equation 50 yields 33.1 kHz and Equation 51 gives 26.9 kHz. Use the lower value of Equation 50 or Equation 51 for an initial crossover frequency. For this example, the target f_{co} is 26.9 kHz.

Next, the compensation components are calculated with Equation 48 through Equation 51. A resistor in series with a capacitor is used to create a compensating zero. A capacitor in parallel to these two components forms the compensating pole.

$$f_{p(mod)} = \frac{I_{OUT(max)}}{2 \times \pi \times V_{OUT} \times C_{OUT}} = \frac{3.5 \text{ A}}{2 \times \pi \times 3.3 \text{ V} \times 70 \mu\text{F}} = 2411 \text{ Hz} \quad (48)$$

$$f_{z(mod)} = \frac{1}{2 \times \pi \times R_{ESR} \times C_{OUT}} = \frac{1}{2 \times \pi \times 5 \text{ m}\Omega \times 70 \mu\text{F}} = 455 \text{ kHz} \quad (49)$$

$$f_{co} = \sqrt{f_{p(mod)} \times f_{z(mod)}} = \sqrt{2411 \text{ Hz} \times 455 \text{ kHz}} = 33.1 \text{ kHz} \quad (50)$$

$$f_{co} = \sqrt{f_{p(mod)} \times \frac{f_{SW}}{2}} = \sqrt{2411 \text{ Hz} \times \frac{600 \text{ kHz}}{2}} = 26.9 \text{ kHz} \quad (51)$$

To determine the compensation resistor, R4, use Equation 52. Assume the power stage transconductance, gm_{ps} , is 12 A/V. The output voltage, V_O , reference voltage, V_{REF} , and amplifier transconductance, gm_{ea} , are 5 V, 0.8 V and 350 μ A/V, respectively. R4 is calculated to be 11.6 k Ω and a standard value of 11.5 k Ω is selected. Use Equation 53 to set the compensation zero to the modulator pole frequency. Equation 53 yields 5740 pF for compensating capacitor C5. 5600 pF is used for this design.

$$R4 = \left(\frac{2 \times \pi \times f_{co} \times C_{OUT}}{gm_{ps}} \right) \times \left(\frac{V_{OUT}}{V_{REF} \times gm_{ea}} \right) = \left(\frac{2 \times \pi \times 26.9 \text{ kHz} \times 70 \mu\text{F}}{12 \text{ A/V}} \right) \times \left(\frac{3.3 \text{ V}}{0.8 \text{ V} \times 350 \mu\text{A/V}} \right) = 11.6 \text{ k}\Omega \quad (52)$$

$$C5 = \frac{1}{2 \times \pi \times R4 \times f_{p(mod)}} = \frac{1}{2 \times \pi \times 11.5 \text{ k}\Omega \times 2411 \text{ Hz}} = 5740 \text{ pF} \quad (53)$$

A compensation pole can be implemented if desired by adding capacitor C8 in parallel with the series combination of R4 and C5. Use the larger value calculated from Equation 54 and Equation 55 for C8 to set the compensation pole. The selected value of C8 is 47 pF for this design example.

$$C8 = \frac{C_{OUT} \times R_{ESR}}{R4} = \frac{70 \mu\text{F} \times 5 \text{ m}\Omega}{11.5 \text{ k}\Omega} = 30.4 \text{ pF} \quad (54)$$

$$C8 = \frac{1}{R4 \times f_{sw} \times \pi} = \frac{1}{11.5 \text{ k}\Omega \times 600 \text{ kHz} \times \pi} = 46.1 \text{ pF} \quad (55)$$

8.2.2.11 Discontinuous Conduction Mode and Eco-mode Boundary

With an input voltage of 12 V, the power supply enters discontinuous conduction mode when the output current is less than 340 mA. The power supply enters Eco-mode when the output current is lower than 30 mA. The input current draw is 260 μ A with no load.

8.2.2.12 Estimated Circuit Area

Boxing in the components in the design of Figure 46 the estimated printed circuit board area is 1.025 in² (661 mm²). This area does not include test points or connectors.

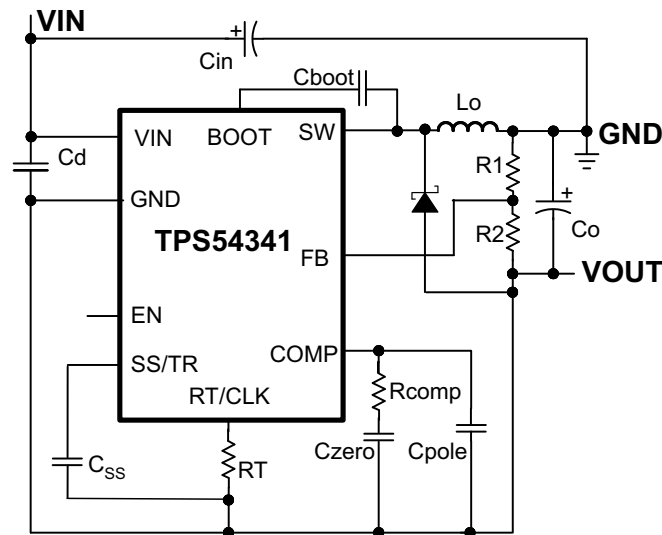

Copyright © 2016, Texas Instruments Incorporated

Figure 47. TPS54341 Inverting Power Supply Based on the Application Note, [SLVA317](#)

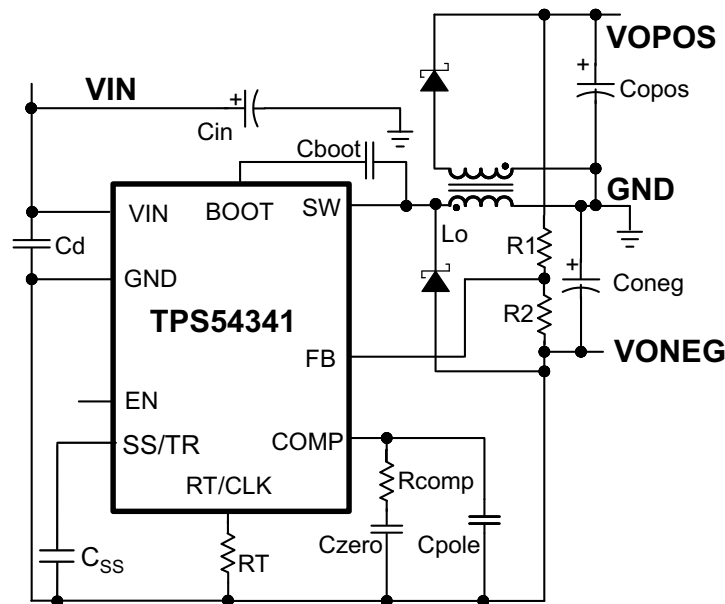

Copyright © 2016, Texas Instruments Incorporated

Figure 48. TPS54341 Split Rail Power Supply Based on the Application Note, [SLVA369](#)

8.2.2.13 Power Dissipation Estimate

The following formulas show how to estimate the TPS54341 power dissipation under continuous conduction mode (CCM) operation. These equations should not be used if the device is operating in discontinuous conduction mode (DCM).

The power dissipation of the IC includes conduction loss (P_{COND}), switching loss (P_{SW}), gate drive loss (P_{GD}) and supply current (P_Q). Example calculations are shown in [Equation 56](#) through [Equation 59](#) with the 12 V typical input voltage of the design example.

$$P_{COND} = (I_{OUT})^2 \times R_{DS(on)} \times \left(\frac{V_{OUT}}{V_{IN}} \right) = 3.5 \text{ A}^2 \times 87 \text{ m}\Omega \times \frac{3.3 \text{ V}}{12 \text{ V}} = 0.31 \text{ W} \quad (56)$$

$$P_{SW} = V_{IN} \times f_{SW} \times I_{OUT} \times t_{rise} = 12 \text{ V} \times 600 \text{ kHz} \times 3.5 \text{ A} \times 4.9 \text{ ns} = 0.123 \text{ W} \quad (57)$$

$$P_{GD} = V_{IN} \times Q_G \times f_{SW} = 12 \text{ V} \times 3 \text{ nC} \times 600 \text{ kHz} = 0.022 \text{ W} \quad (58)$$

$$P_Q = V_{IN} \times I_Q = 12 \text{ V} \times 146 \text{ }\mu\text{A} = 0.0018 \text{ W}$$

where

- I_{OUT} is the output current (A)
- $R_{DS(on)}$ is the on-resistance of the high-side MOSFET (Ω)
- V_{OUT} is the output voltage (V)
- V_{IN} is the input voltage (V)
- f_{SW} is the switching frequency (Hz)
- t_{rise} is the SW pin voltage rise time and can be estimated by $t_{rise} = V_{IN} \times 0.16 \text{ ns/V} + 3 \text{ ns}$
- Q_G is the total gate charge of the internal MOSFET
- I_Q is the operating nonswitching supply current

Therefore, use [Equation 60](#).

$$P_{TOT} = P_{COND} + P_{SW} + P_{GD} + P_Q = 0.31 \text{ W} + 0.123 \text{ W} + 0.022 \text{ W} + 0.0018 \text{ W} = 0.457 \text{ W} \quad (60)$$

For given T_A , use [Equation 61](#).

$$T_J = T_A + R_{TH} \times P_{TOT} \quad (61)$$

For given $T_{J(MAX)} = 150^\circ\text{C}$, use [Equation 62](#).

$$T_{A(max)} = T_{J(max)} - R_{TH} \times P_{TOT}$$

where

- P_{TOT} is the total device power dissipation (W)
- T_A is the ambient temperature (°C)
- T_J is the junction temperature (°C)
- R_{TH} is the thermal resistance (°C/W)
- $T_{J(MAX)}$ is maximum junction temperature (°C)
- $T_{A(MAX)}$ is maximum ambient temperature (°C)

(62)

There will be additional power losses in the regulator circuit due to the inductor ac and dc losses, the catch diode and PCB trace resistance impacting the overall efficiency of the regulator.

8.2.3 Application Curves

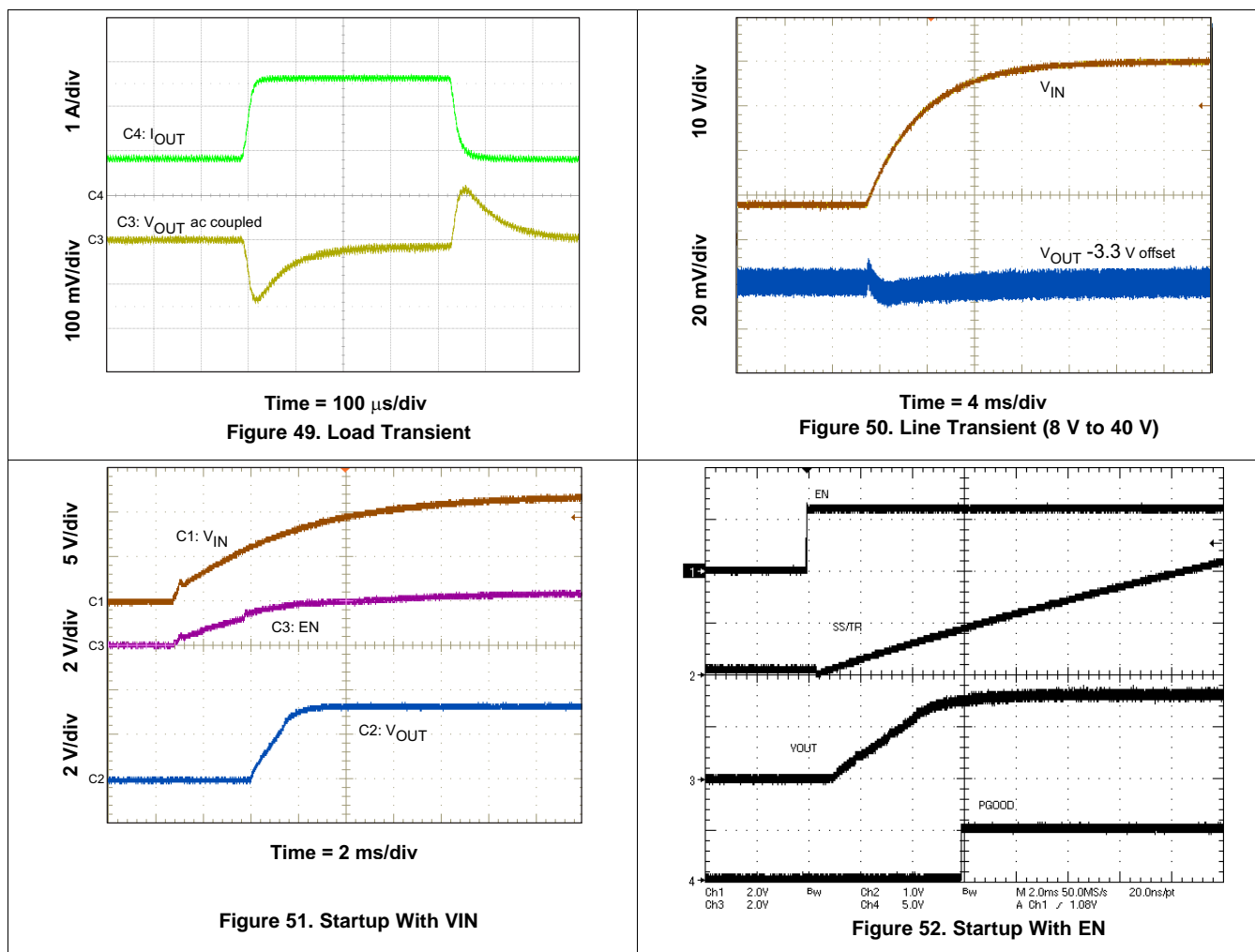

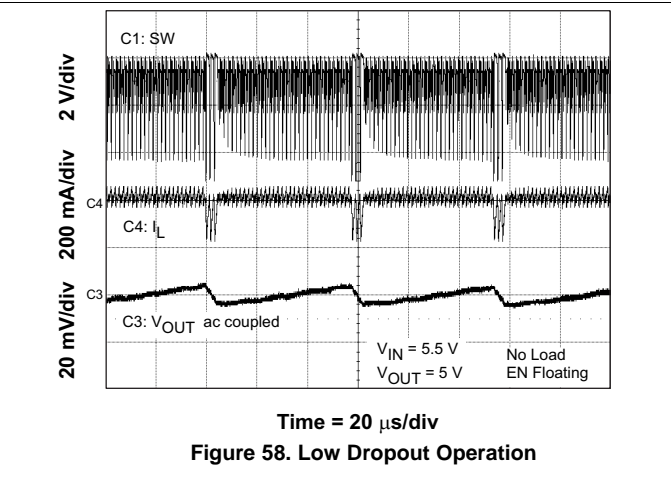
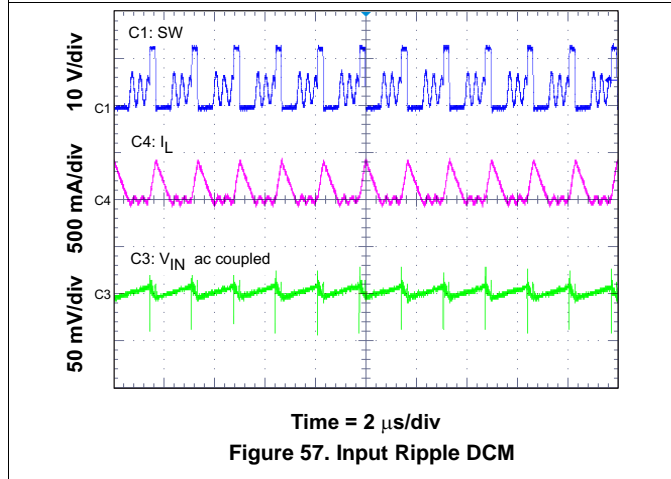
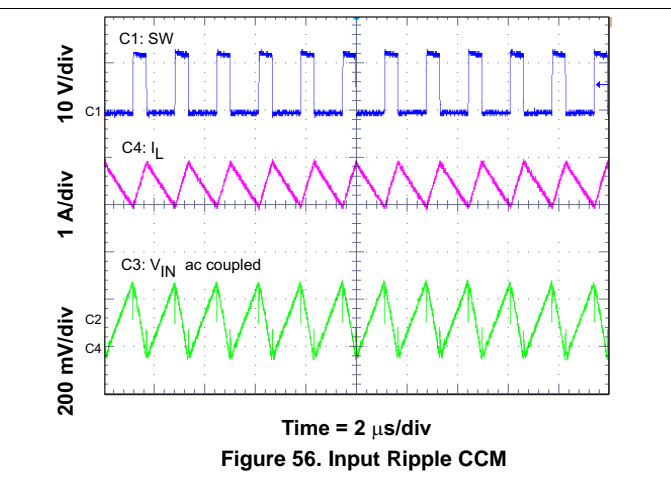
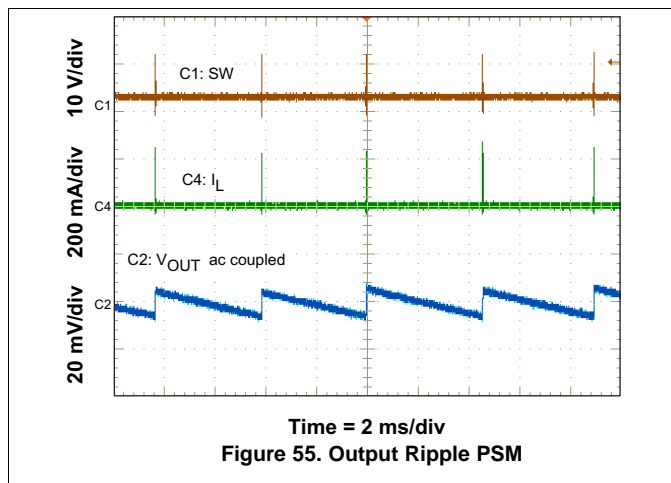
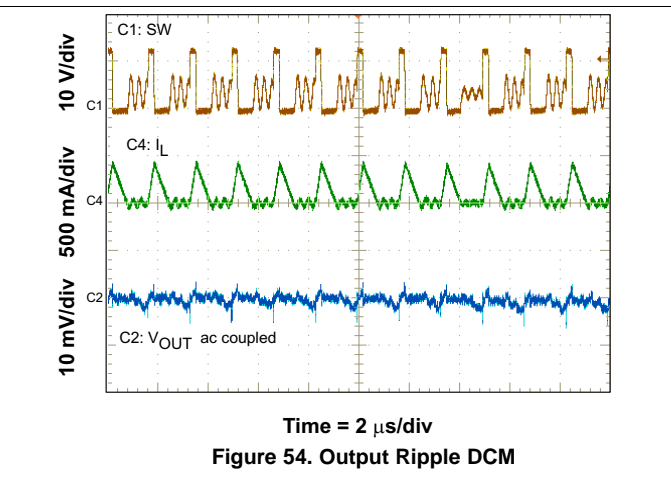
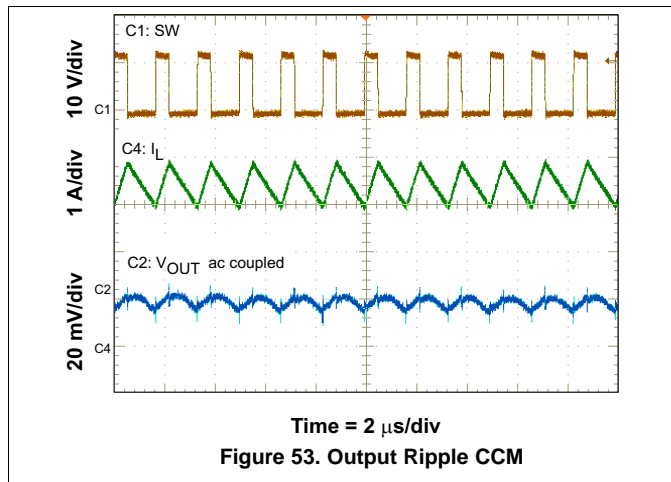

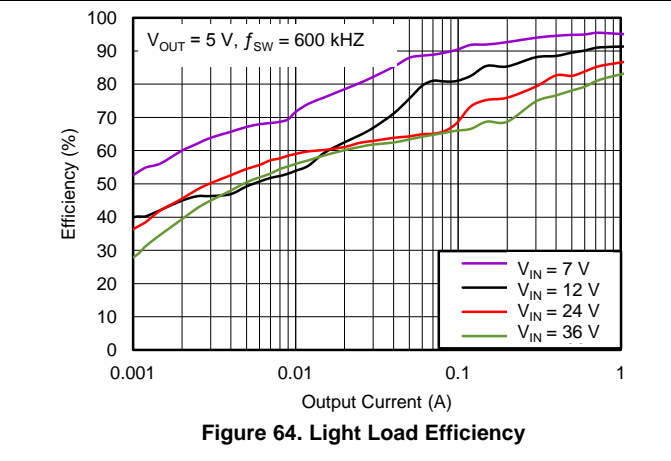
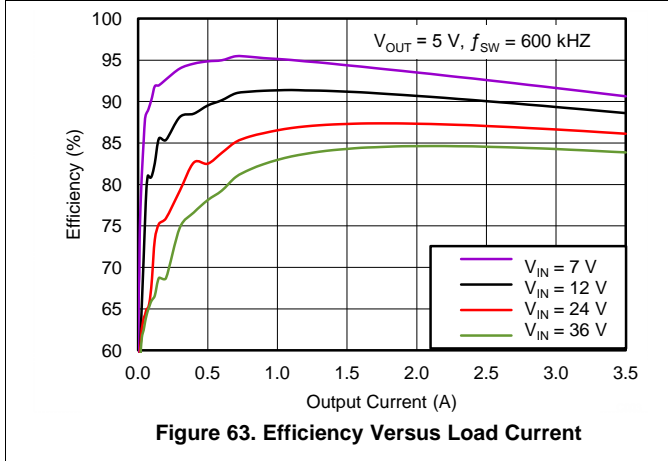
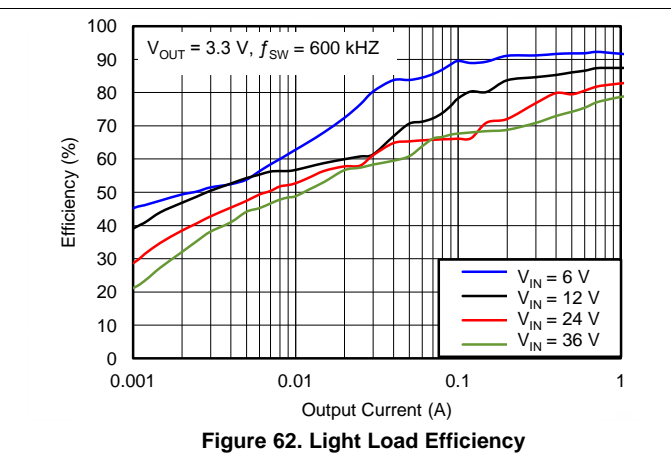
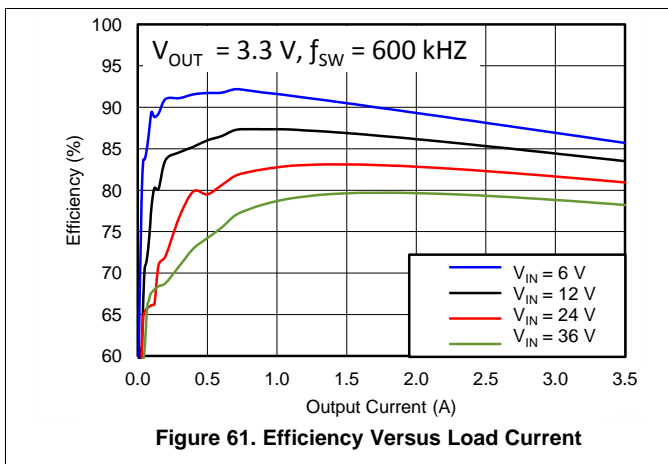
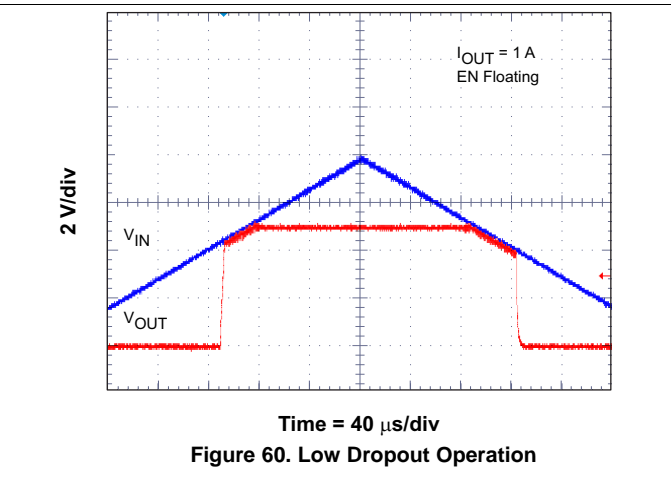
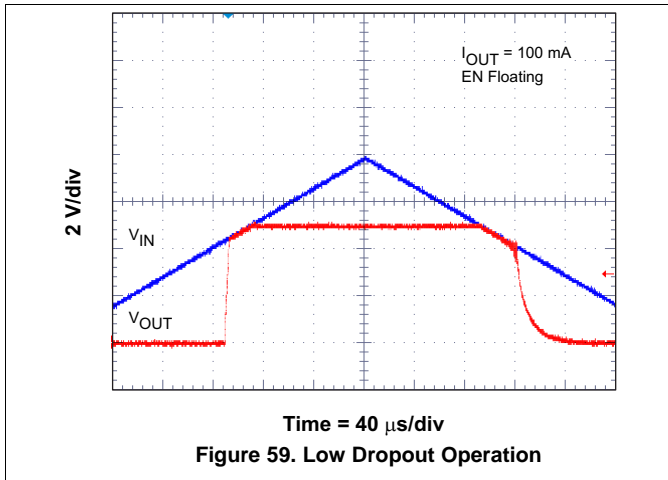

TPS54341

SLVSC61A –NOVEMBER 2013–REVISED OCTOBER 2016

www.ti.com

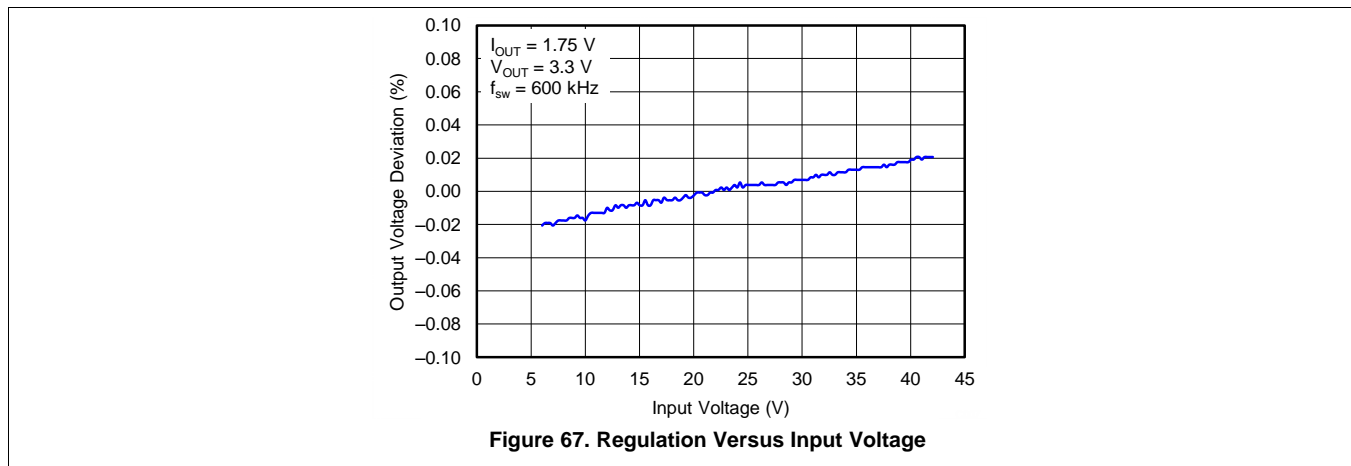
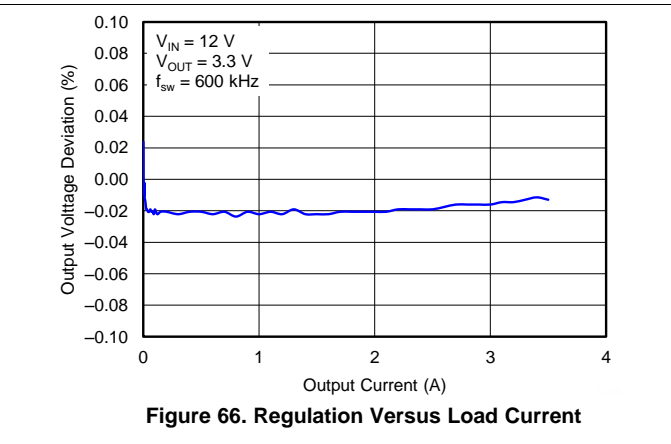
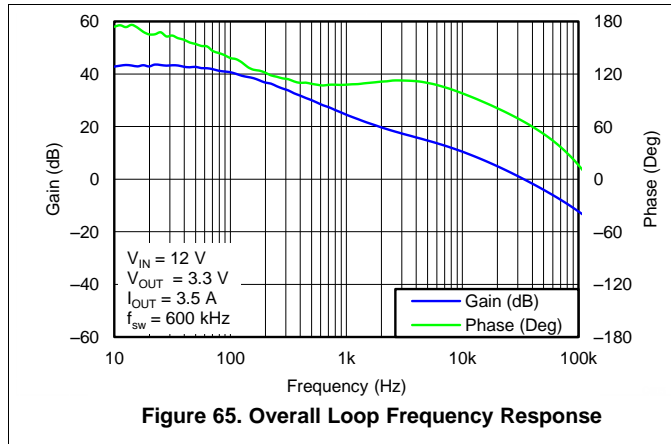

9 Power Supply Recommendations

The device are designed to operate from an input voltage supply range between 4.5 V and 42 V. If the input supply is located more than a few inches from the TPS54340 converter additional bulk capacitance may be required in addition to the ceramic bypass capacitors. An electrolytic capacitor with a value of 100 μ F is a typical choice.

10 Layout

10.1 Layout Guidelines

Layout is a critical portion of good power supply design. There are several signal paths that conduct fast changing currents or voltages that can interact with stray inductance or parasitic capacitance to generate noise or degrade performance. To reduce parasitic effects, the VIN pin should be bypassed to ground with a low ESR ceramic bypass capacitor with X5R or X7R dielectric. Care should be taken to minimize the loop area formed by the bypass capacitor connections, the VIN pin, and the anode of the catch diode. See Figure 68 for a PCB layout example. The GND pin should be tied directly to the power pad under the IC and the power pad.

The power pad should be connected to internal PCB ground planes using multiple vias directly under the IC. The SW pin should be routed to the cathode of the catch diode and to the output inductor. Because the SW connection is the switching node, the catch diode and output inductor should be located close to the SW pins, and the area of the PCB conductor minimized to prevent excessive capacitive coupling. For operation at full rated load, the top side ground area must provide adequate heat dissipating area. The RT/CLK pin is sensitive to noise so the RT resistor should be located as close as possible to the IC and routed with minimal lengths of trace. The additional external components can be placed approximately as shown. It may be possible to obtain acceptable performance with alternate PCB layouts, however this layout has been shown to produce good results and is meant as a guideline.

10.2 Layout Example

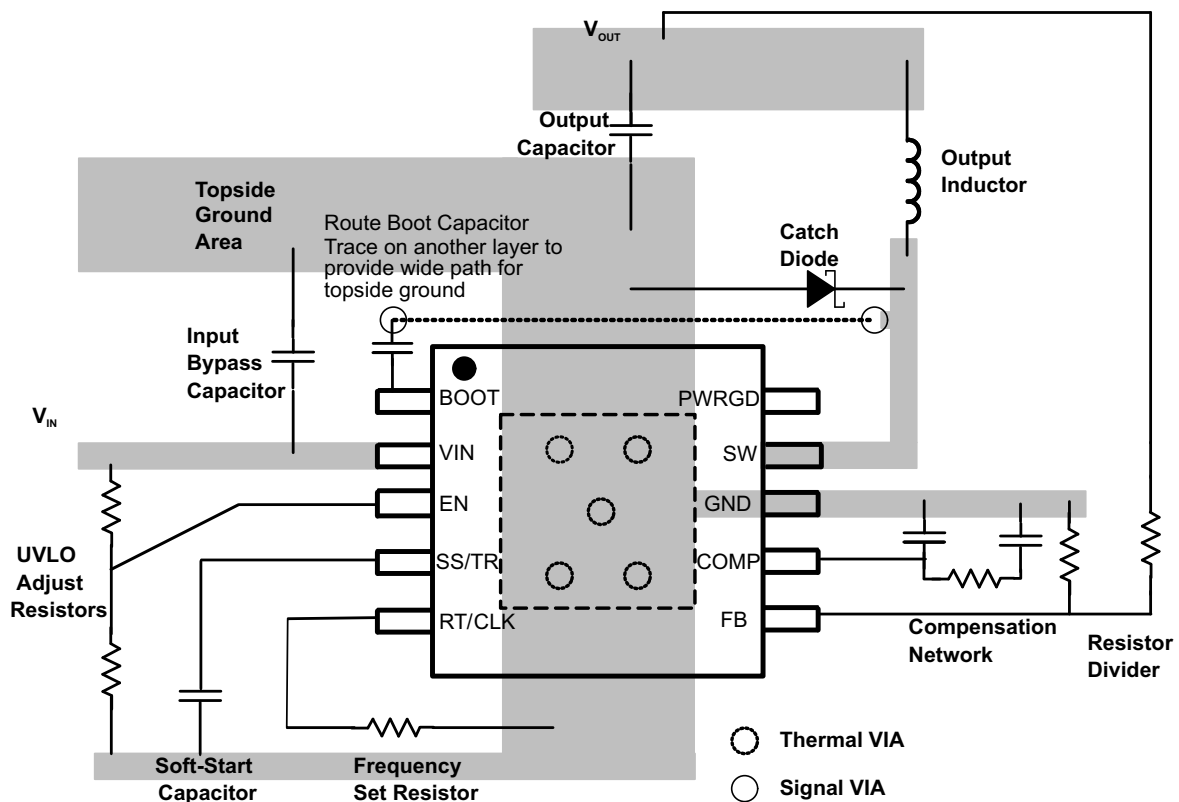

Figure 68. PCB Layout Example

11 Device and Documentation Support

11.1 Device Support

11.1.1 Third-Party Products Disclaimer

TI'S PUBLICATION OF INFORMATION REGARDING THIRD-PARTY PRODUCTS OR SERVICES DOES NOT CONSTITUTE AN ENDORSEMENT REGARDING THE SUITABILITY OF SUCH PRODUCTS OR SERVICES OR A WARRANTY, REPRESENTATION OR ENDORSEMENT OF SUCH PRODUCTS OR SERVICES, EITHER ALONE OR IN COMBINATION WITH ANY TI PRODUCT OR SERVICE.

11.2 Documentation Support

11.2.1 Related Documentation

For related documentation see the following:

- *Creating GSM/GRPS Power Supply from TPS54260*, [SLVA412](#)
- *Creating a Universal Car Charger for USB devices From the TPS54240 and TPS2511*, [SLVA464](#)
- *Create an Inverting Power Supply From a Step-Down Regulator*, [SLVA317](#)
- *Creating a Split-Rail Power Supply With a Wide Input Voltage Buck Regulator*, [SLVA369](#)

11.3 Receiving Notification of Documentation Updates

To receive notification of documentation updates, navigate to the device product folder on ti.com. In the upper right corner, click on *Alert me* to register and receive a weekly digest of any product information that has changed. For change details, review the revision history included in any revised document.

11.4 Community Resources

The following links connect to TI community resources. Linked contents are provided "AS IS" by the respective contributors. They do not constitute TI specifications and do not necessarily reflect TI's views; see TI's [Terms of Use](#).

TI E2E™ Online Community *TI's Engineer-to-Engineer (E2E) Community*. Created to foster collaboration among engineers. At e2e.ti.com, you can ask questions, share knowledge, explore ideas and help solve problems with fellow engineers.

Design Support *TI's Design Support* Quickly find helpful E2E forums along with design support tools and contact information for technical support.

11.5 Trademarks

Eco-mode, E2E are trademarks of Texas Instruments.
WEBENCH is a registered trademark of Texas Instruments.
All other trademarks are the property of their respective owners.

11.6 Electrostatic Discharge Caution



This integrated circuit can be damaged by ESD. Texas Instruments recommends that all integrated circuits be handled with appropriate precautions. Failure to observe proper handling and installation procedures can cause damage.

ESD damage can range from subtle performance degradation to complete device failure. Precision integrated circuits may be more susceptible to damage because very small parametric changes could cause the device not to meet its published specifications.

11.7 Glossary

[SLYZ022](#) — *TI Glossary*.

This glossary lists and explains terms, acronyms, and definitions.

12 Mechanical, Packaging, and Orderable Information

The following pages include mechanical, packaging, and orderable information. This information is the most current data available for the designated devices. This data is subject to change without notice and revision of this document. For browser-based versions of this data sheet, refer to the left-hand navigation.

PACKAGING INFORMATION

Orderable Device	Status (1)	Package Type	Package Drawing	Pins	Package Qty	Eco Plan (2)	Lead finish/ Ball material (6)	MSL Peak Temp (3)	Op Temp (°C)	Device Marking (4/5)	Samples
TPS54341DPRR	ACTIVE	WSON	DPR	10	3000	RoHS & Green	NIPDAU	Level-1-260C-UNLIM	-40 to 85	TPS 54341	Samples
TPS54341DPRT	ACTIVE	WSON	DPR	10	250	RoHS & Green	NIPDAU	Level-1-260C-UNLIM	-40 to 85	TPS 54341	Samples

(1) The marketing status values are defined as follows:

ACTIVE: Product device recommended for new designs.

LIFEBUY: TI has announced that the device will be discontinued, and a lifetime-buy period is in effect.

NRND: Not recommended for new designs. Device is in production to support existing customers, but TI does not recommend using this part in a new design.

PREVIEW: Device has been announced but is not in production. Samples may or may not be available.

OBSOLETE: TI has discontinued the production of the device.

(2) **RoHS:** TI defines "RoHS" to mean semiconductor products that are compliant with the current EU RoHS requirements for all 10 RoHS substances, including the requirement that RoHS substance do not exceed 0.1% by weight in homogeneous materials. Where designed to be soldered at high temperatures, "RoHS" products are suitable for use in specified lead-free processes. TI may reference these types of products as "Pb-Free".

RoHS Exempt: TI defines "RoHS Exempt" to mean products that contain lead but are compliant with EU RoHS pursuant to a specific EU RoHS exemption.

Green: TI defines "Green" to mean the content of Chlorine (Cl) and Bromine (Br) based flame retardants meet JS709B low halogen requirements of <=1000ppm threshold. Antimony trioxide based flame retardants must also meet the <=1000ppm threshold requirement.

(3) MSL, Peak Temp. - The Moisture Sensitivity Level rating according to the JEDEC industry standard classifications, and peak solder temperature.

(4) There may be additional marking, which relates to the logo, the lot trace code information, or the environmental category on the device.

(5) Multiple Device Markings will be inside parentheses. Only one Device Marking contained in parentheses and separated by a "~" will appear on a device. If a line is indented then it is a continuation of the previous line and the two combined represent the entire Device Marking for that device.

(6) Lead finish/Ball material - Orderable Devices may have multiple material finish options. Finish options are separated by a vertical ruled line. Lead finish/Ball material values may wrap to two lines if the finish value exceeds the maximum column width.

Important Information and Disclaimer: The information provided on this page represents TI's knowledge and belief as of the date that it is provided. TI bases its knowledge and belief on information provided by third parties, and makes no representation or warranty as to the accuracy of such information. Efforts are underway to better integrate information from third parties. TI has taken and continues to take reasonable steps to provide representative and accurate information but may not have conducted destructive testing or chemical analysis on incoming materials and chemicals. TI and TI suppliers consider certain information to be proprietary, and thus CAS numbers and other limited information may not be available for release.

In no event shall TI's liability arising out of such information exceed the total purchase price of the TI part(s) at issue in this document sold by TI to Customer on an annual basis.

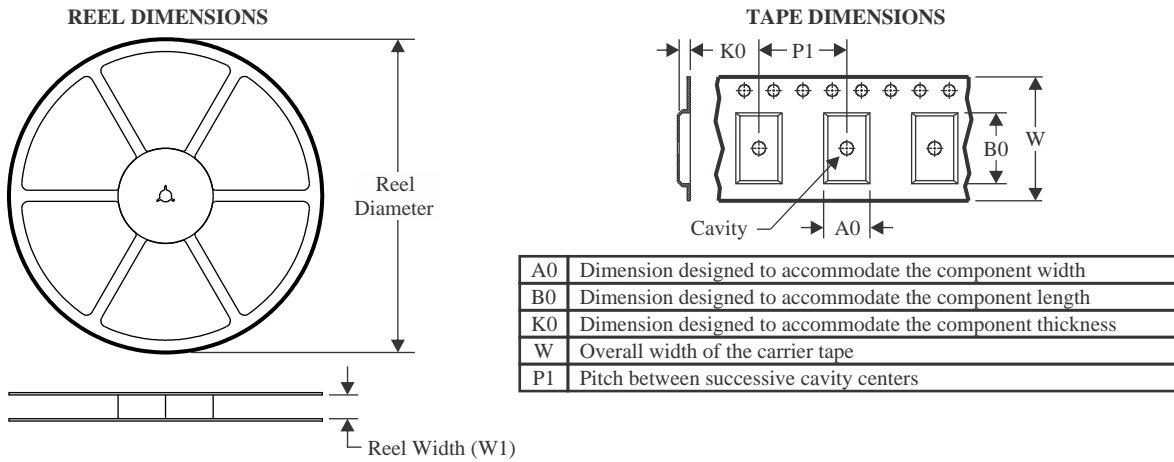
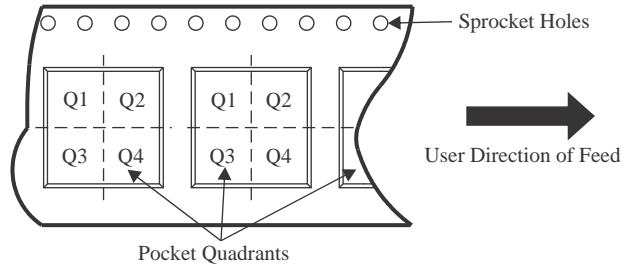
TAPE AND REEL INFORMATION

QUADRANT ASSIGNMENTS FOR PIN 1 ORIENTATION IN TAPE

*All dimensions are nominal

Device	Package Type	Package Drawing	Pins	SPQ	Reel Diameter (mm)	Reel Width W1 (mm)	A0 (mm)	B0 (mm)	K0 (mm)	P1 (mm)	W (mm)	Pin1 Quadrant
TPS54341DPRR	WSON	DPR	10	3000	330.0	12.4	4.25	4.25	1.15	8.0	12.0	Q2
TPS54341DPRT	WSON	DPR	10	250	180.0	12.4	4.25	4.25	1.15	8.0	12.0	Q2

TAPE AND REEL BOX DIMENSIONS

*All dimensions are nominal

Device	Package Type	Package Drawing	Pins	SPQ	Length (mm)	Width (mm)	Height (mm)
TPS54341DPRR	WSON	DPR	10	3000	346.0	346.0	33.0
TPS54341DPRT	WSON	DPR	10	250	182.0	182.0	20.0

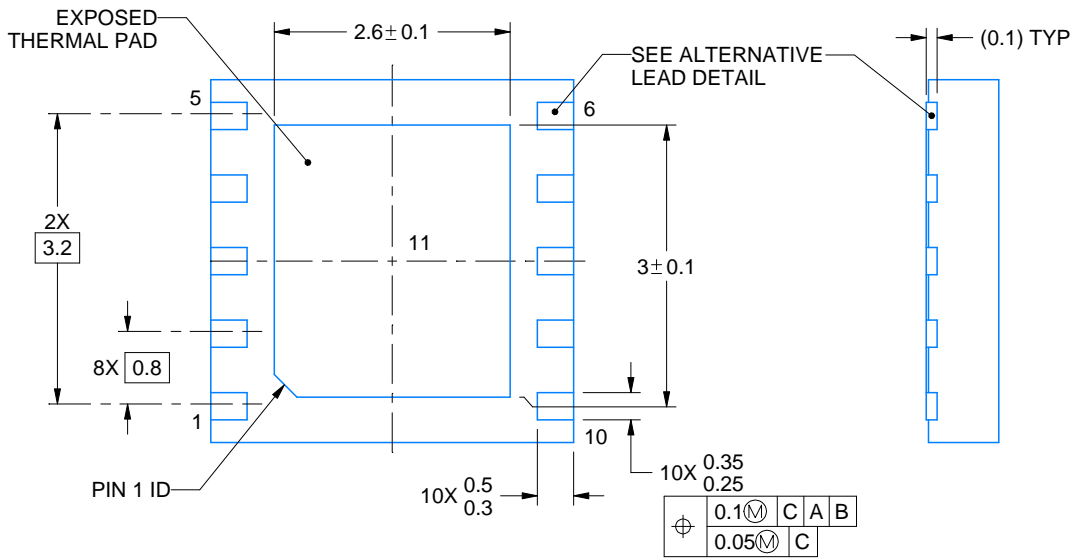
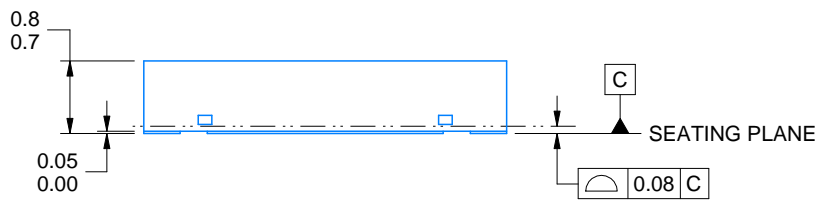
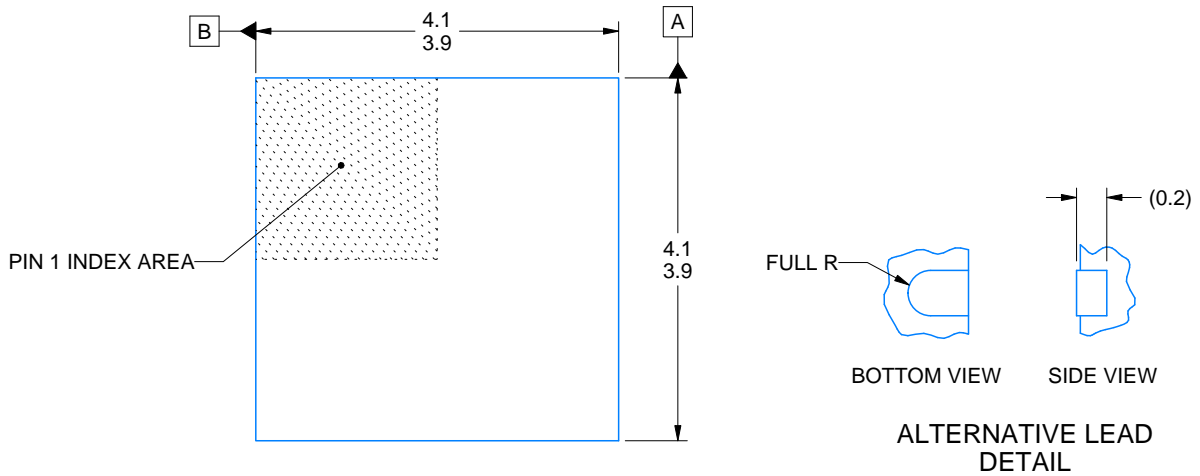
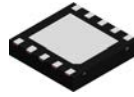

4218856/B 01/2021

NOTES:

1. All linear dimensions are in millimeters. Any dimensions in parenthesis are for reference only. Dimensioning and tolerancing per ASME Y14.5M.
2. This drawing is subject to change without notice.
3. The package thermal pad must be soldered to the printed circuit board for thermal and mechanical performance.

EXAMPLE BOARD LAYOUT

DPR0010A

WSON - 0.8 mm max height

PLASTIC SMALL OUTLINE - NO LEAD

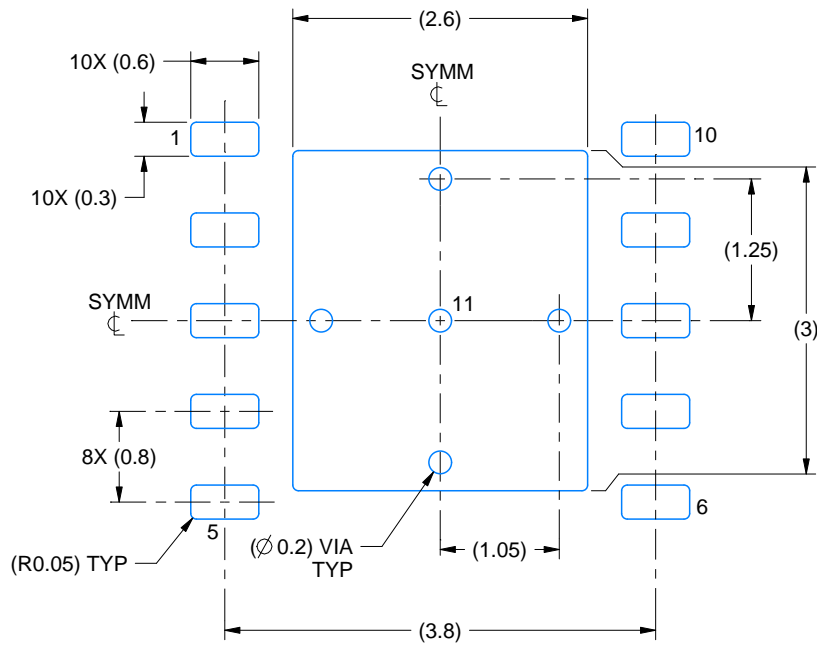

LAND PATTERN EXAMPLE
EXPOSED METAL SHOWN
SCALE:15X

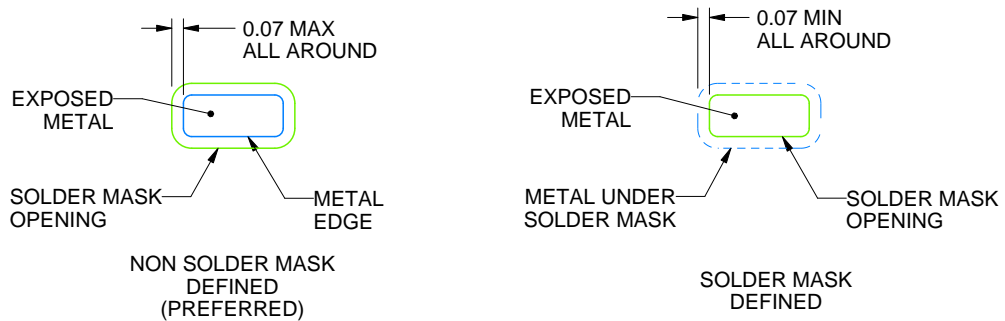

SOLDER MASK DETAILS

4218856/B 01/2021

NOTES: (continued)

4. This package is designed to be soldered to a thermal pad on the board. For more information, see Texas Instruments literature number SLUA271 (www.ti.com/lit/slua271).

EXAMPLE STENCIL DESIGN

DPR0010A

WSN - 0.8 mm max height

PLASTIC SMALL OUTLINE - NO LEAD

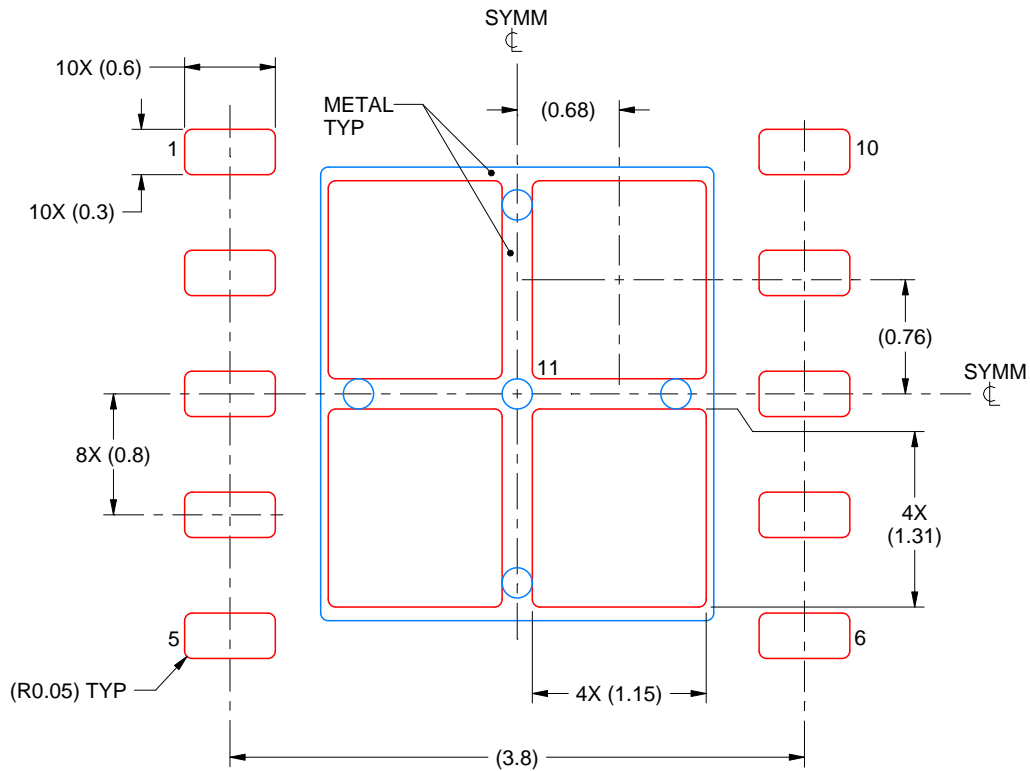

SOLDER PASTE EXAMPLE
BASED ON 0.125 mm THICK STENCIL

EXPOSED PAD 11:
77% PRINTED SOLDER COVERAGE BY AREA
SCALE:20X

4218856/B 01/2021

NOTES: (continued)

5. Laser cutting apertures with trapezoidal walls and rounded corners may offer better paste release. IPC-7525 may have alternate design recommendations.

IMPORTANT NOTICE AND DISCLAIMER

TI PROVIDES TECHNICAL AND RELIABILITY DATA (INCLUDING DATA SHEETS), DESIGN RESOURCES (INCLUDING REFERENCE DESIGNS), APPLICATION OR OTHER DESIGN ADVICE, WEB TOOLS, SAFETY INFORMATION, AND OTHER RESOURCES "AS IS" AND WITH ALL FAULTS, AND DISCLAIMS ALL WARRANTIES, EXPRESS AND IMPLIED, INCLUDING WITHOUT LIMITATION ANY IMPLIED WARRANTIES OF MERCHANTABILITY, FITNESS FOR A PARTICULAR PURPOSE OR NON-INFRINGEMENT OF THIRD PARTY INTELLECTUAL PROPERTY RIGHTS.

These resources are intended for skilled developers designing with TI products. You are solely responsible for (1) selecting the appropriate TI products for your application, (2) designing, validating and testing your application, and (3) ensuring your application meets applicable standards, and any other safety, security, regulatory or other requirements.

These resources are subject to change without notice. TI grants you permission to use these resources only for development of an application that uses the TI products described in the resource. Other reproduction and display of these resources is prohibited. No license is granted to any other TI intellectual property right or to any third party intellectual property right. TI disclaims responsibility for, and you will fully indemnify TI and its representatives against, any claims, damages, costs, losses, and liabilities arising out of your use of these resources.

TI's products are provided subject to [TI's Terms of Sale](#) or other applicable terms available either on [ti.com](https://www.ti.com) or provided in conjunction with such TI products. TI's provision of these resources does not expand or otherwise alter TI's applicable warranties or warranty disclaimers for TI products.

TI objects to and rejects any additional or different terms you may have proposed.

Mailing Address: Texas Instruments, Post Office Box 655303, Dallas, Texas 75265
Copyright © 2023, Texas Instruments Incorporated

Looking for pricing, stock, or lifecycle information?

Click below to explore more details on WIN SOURCE:

 [View TPS54341DPRR](#) on WIN SOURCE

 [Texas Instruments](#) Information

Optimize Your Supply Chain with WIN SOURCE Solutions

-  Global Sourcing Solution
-  Obsolete Management
-  Cost Control Management
-  Shortage Management
-  Alternative Solution
-  Excess Inventory Management