



**THE DATASHEET OF
ADS8339IDGSR**



ADS8339 16-Bit, 250-kSPS, Serial Interface, Micro-Power, Miniature, SAR Analog-to-Digital Converter

1 Features

- Sample Rate: 250 kHz
- 16-Bit Resolution
- Zero Latency at Full Speed
- Unipolar Single-Ended Input Range:
 - 0 V to V_{ref}
- SPI™-Compatible Serial Interface with Daisy-Chain Option
- Uses Internal Clock for Conversion
- Excellent Performance:
 - 93.6 dB SNR (typ) at 10-kHz Input
 - –106 dB THD (typ) at 10-kHz Input
 - ± 2.0 LSB INL (max)
 - ± 1.0 LSB DNL (max)
- Low-Power Dissipation:
 - 17.5 mW (typ) at 250 kSPS
- Power Scales Linearly with Speed:
 - 1.75 mW at 25 kSPS
- Power Dissipation During Power-Down State:
 - 0.25 μ W (typ)
- Package: VSSOP-10

2 Applications

- Battery-Powered Equipment
- Data Acquisition Systems
- Instrumentation and Process Controls
- Medical Electronics
- Optical Networking

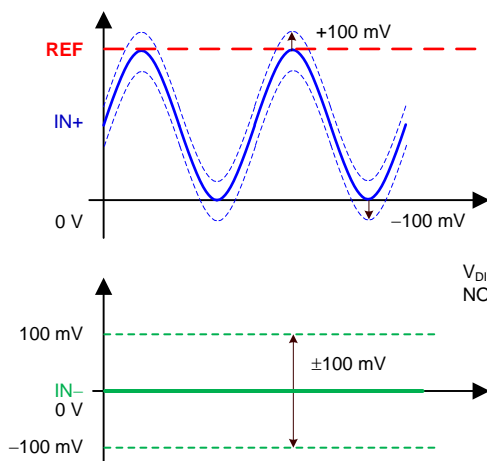

3 Description

The ADS8339 is a 16-bit, 250-kSPS, analog-to-digital converter (ADC). The device operates with a 2.25-V to 5.5-V external reference. The device includes a capacitor-based, successive-approximation register (SAR) ADC with an inherent sample-and-hold circuit.

The device includes a 25-MHz, SPI-compatible serial interface. The interface is designed to support daisy-chaining or cascading of multiple devices. Furthermore, a busy indicator makes synchronizing with the digital host easy. The unipolar, single-ended input range for the device supports an input swing of 0 V to V_{ref} .

The device is optimized for low-power operation and power consumption scales directly with speed. This feature makes the device attractive for lower speed applications. The ADS8339 is available in a VSSOP-10 package.

Device Information⁽¹⁾

PART NUMBER	PACKAGE	BODY SIZE (NOM)
ADS8339	VSSOP (10)	3.00 mm x 3.00 mm

(1) For all available packages, see the orderable addendum at the end of the datasheet.

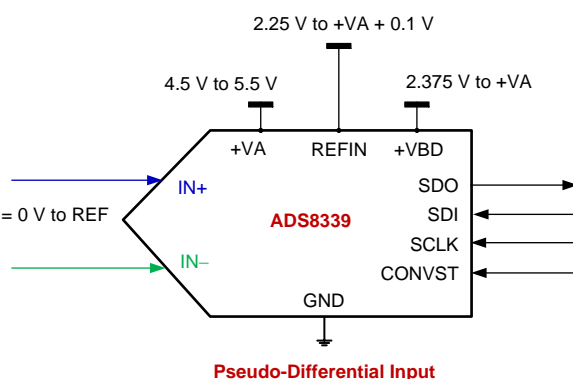

Table of Contents

1 Features	1	9.2 Functional Block Diagram	16
2 Applications	1	9.3 Feature Description.....	17
3 Description	1	9.4 Device Functional Modes.....	18
4 Revision History	2	10 Application and Implementation	26
5 Device Family	3	10.1 Application Information.....	26
6 Pin Configuration and Functions	3	10.2 Typical Application	30
7 Specifications	4	10.3 Do's and Don'ts	31
7.1 Absolute Maximum Ratings	4	11 Power-Supply Recommendations	31
7.2 Handling Ratings.....	4	12 Layout	32
7.3 Recommended Operating Conditions	4	12.1 Layout Guidelines	32
7.4 Thermal Information	5	12.2 Layout Example	32
7.5 Electrical Characteristics.....	5	13 Device and Documentation Support	33
7.6 Timing Requirements	7	13.1 Documentation Support	33
7.7 Typical Characteristics	8	13.2 Trademarks	33
8 Parametric Measurement Information	15	13.3 Electrostatic Discharge Caution.....	33
8.1 Timing Diagrams	15	13.4 Glossary	33
9 Detailed Description	16	14 Mechanical, Packaging, and Orderable Information	33
9.1 Overview	16		

4 Revision History

Changes from Original (June 2014) to Revision A	Page
• Made changes to product preview data sheet.....	1

5 Device Family⁽¹⁾

SAMPLING RATE	16-BIT, SINGLE-ENDED	16-BIT, DIFFERENTIAL	18-BIT, DIFFERENTIAL
100 kSPS	ADS8866	ADS8867	ADS8887
250 kSPS	ADS8339	—	—
400 kSPS	ADS8864	ADS8865	ADS8885
500 kSPS	ADS8319	ADS8318	—
680 kSPS	ADS8862	ADS8863	ADS8883
1 MSPS	ADS8860	ADS8861	ADS8881

- (1) All devices are pin-to-pin compatible. The ADS8339, ADS8319, and ADS8318 require a 4.5-V to 5.5-V analog supply. The remaining devices use a 2.7-V to 3.6-V analog supply.

6 Pin Configuration and Functions

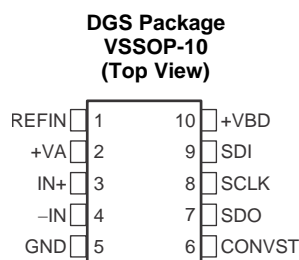

Pin Functions

PIN		FUNCTION	DESCRIPTION
NO.	NAME		
1	REFIN	Input	Reference (positive) input. Decouple to GND with a 0.1- μ F bypass capacitor and a 10- μ F storage capacitor.
2	+VA	Supply	Analog power supply. Decouple with the GND pin.
3	+IN	Input	Noninverting analog signal input
4	-IN	Input	Inverting analog signal input. Note that this input has a limited range of ± 0.1 V and is typically grounded at the input decoupling capacitor.
5	GND	Supply	Device ground. Note that this pin is a common ground pin for both the analog power supply (+VA) and digital I/O supply (+VBD).
6	CONVST	Input	Convert input. CONVST also functions as the \overline{CS} input in 3-wire interface mode. Refer to the Description and Timing Diagrams sections for more details.
7	SDO	Output	Serial data output
8	SCLK	Input	Serial I/O clock input. Data (on the SDO output) are synchronized with this clock.
9	SDI	Input	Serial data input. The SDI level at the start of a conversion selects the mode of operation (such as \overline{CS} or daisy-chain mode). SDI also serves as the \overline{CS} input in 4-wire interface mode. Refer to the Description and Timing Diagrams sections for more details.
10	+VBD	Supply	Digital I/O power supply. Decouple with the GND pin.

7 Specifications

7.1 Absolute Maximum Ratings

 over operating free-air temperature range (unless otherwise noted)⁽¹⁾

		MIN	MAX	UNIT
+IN, –IN input	Voltage	–0.3	+VA + 0.3	V
	Momentary current ⁽²⁾		130	mA
	Continuous current		±10	mA
+VA to GND		–0.3	7	V
+VBD to GND		–0.3	7	V
Digital input voltage to GND		–0.3	+VBD + 0.3	V
Digital output voltage to GND		–0.3	+VBD + 0.3	V
Temperature	Operating free-air range, T _A	–40	85	°C
	Junction, T _J max		150	°C
VSSOP package	Power dissipation		(T _J max – T _A) / θ _{JA}	°C
	θ _{JA} thermal impedance		121.1	°C/W
Maximum VSSOP reflow temperature ⁽³⁾			260	°C

- (1) Stresses beyond those listed under *Absolute Maximum Ratings* may cause permanent damage to the device. These are stress ratings only, which do not imply functional operation of the device at these or any other conditions beyond those indicated under *Recommended Operating Conditions*. Exposure to absolute-maximum-rated conditions for extended periods may affect device reliability.
- (2) Limit the duration for this current to less than 10 ms.
- (3) The device is rated at MSL2, 260°C, as per the JSTD-020 specification.

7.2 Handling Ratings

			MIN	MAX	UNIT
T _{stg}	Storage temperature range		–65	150	°C
V _(ESD)	Electrostatic discharge	Human body model (HBM), per ANSI/ESDA/JEDEC JS-001, all pins ⁽¹⁾	–1000	1000	V
		Charged device model (CDM), per JEDEC specification JESD22-C101, all pins ⁽²⁾	–250	250	

- (1) JEDEC document JEP155 states that 500-V HBM allows safe manufacturing with a standard ESD control process.
- (2) JEDEC document JEP157 states that 250-V CDM allows safe manufacturing with a standard ESD control process.

7.3 Recommended Operating Conditions

over operating free-air temperature range (unless otherwise noted)

		MIN	NOM	MAX	UNIT
V _{+VA}	Analog power-supply voltage	4.5	5.0	5.5	V
V _{+VBD}	Digital I/O-supply voltage	2.375	3.3	5.5	V
V _{ref}	Reference voltage	2.25	4.096	V _{+VA} + 0.1	V
f _(SCLK)	SCLK frequency			25	MHz
T _A	Operating temperature range	–40		85	°C

7.4 Thermal Information

THERMAL METRIC ⁽¹⁾		ADS8339	UNIT
		DGS (VSSOP)	
		10 PINS	
R _{θJA}	Junction-to-ambient thermal resistance	121.1	°C/W
R _{θJC(top)}	Junction-to-case (top) thermal resistance	29.4	
R _{θJB}	Junction-to-board thermal resistance	32.0	
ψ _{JT}	Junction-to-top characterization parameter	0.7	
ψ _{JB}	Junction-to-board characterization parameter	31.5	
R _{θJC(bot)}	Junction-to-case (bottom) thermal resistance	N/A	

(1) For more information about traditional and new thermal metrics, see the *IC Package Thermal Metrics* application report, [SPRA953](#).

7.5 Electrical Characteristics

All minimum and maximum specifications are at T_A = –40°C to 85°C, +V_A = 5 V, +V_{BD} = 5 V to 2.375 V, V_{ref} = 4 V, and f_{sample} = 250 kHz, unless otherwise noted. Typical specifications are at T_A = 25°C.

PARAMETER	TEST CONDITIONS	MIN	TYP	MAX	UNIT
ANALOG INPUT					
Full-scale input span ⁽¹⁾	+IN – (–IN)	0		V _{ref}	V
Operating input range	+IN	–0.1		V _{ref} + 0.1	V
	–IN	–0.1		0.1	V
C _i	Input capacitance		59		pF
	Input leakage current	During acquisition		1000	pA
SYSTEM PERFORMANCE					
	Resolution		16		Bits
NMC	No missing codes		16		Bits
INL	Integral linearity ⁽²⁾	–2.0	±1.2	2.0	LSB ⁽³⁾
DNL	Differential linearity	At 16-bit level		1.0	LSB
E _O	Offset error ⁽⁴⁾	–1.5	±0.3	1.5	mV
E _G	Gain error	–0.03	±0.0045	0.03	%FSR
CMRR	Common-mode rejection ratio	With common-mode input signal = 200 mV _{pp} at 250 kHz		78	dB
PSRR	Power-supply rejection ratio	At FFF0h output code		80	dB
	Transition noise		0.5		LSB
SAMPLING DYNAMICS					
t _{cnv}	Conversion time		500 ⁽⁵⁾	3300	ns
t _{acq}	Acquisition time		700		ns
	Maximum throughput rate with or without latency			0.25	MHz
	Aperture delay		2.5		ns
	Aperture jitter, RMS		6		ps
	Step response	Settling to 16-bit accuracy		600	ns
	Overvoltage recovery	Settling to 16-bit accuracy		600	ns

(1) Ideal input span, does not include gain or offset error.

(2) This parameter is the endpoint INL, not best-fit INL.

(3) LSB = least significant bit.

(4) Measured relative to actual measured reference.

(5) Refer to the [CS Mode for a 3-Wire Interface](#) section in the *Device Functional Modes*.

Electrical Characteristics (continued)

All minimum and maximum specifications are at $T_A = -40^{\circ}\text{C}$ to 85°C , $+VA = 5\text{ V}$, $+VBD = 5\text{ V}$ to 2.375 V , $V_{ref} = 4\text{ V}$, and $f_{\text{sample}} = 250\text{ kHz}$, unless otherwise noted. Typical specifications are at $T_A = 25^{\circ}\text{C}$.

PARAMETER		TEST CONDITIONS	MIN	TYP	MAX	UNIT
DYNAMIC CHARACTERISTICS						
THD	Total harmonic distortion ⁽⁶⁾	$V_{IN} = 0.4\text{ dB below } f_S \text{ at } 1\text{ kHz, } V_{ref} = 5\text{ V}$		-111		dB
		$V_{IN} = 0.4\text{ dB below } f_S \text{ at } 10\text{ kHz, } V_{ref} = 5\text{ V}$		-106		dB
SNR	Signal-to-noise ratio	$V_{IN} = 0.4\text{ dB below } f_S \text{ at } 1\text{ kHz, } V_{ref} = 5\text{ V}$		93.9		dB
		$V_{IN} = 0.4\text{ dB below } f_S \text{ at } 10\text{ kHz, } V_{ref} = 5\text{ V}$		93.6		dB
SINAD	Signal-to-noise + distortion	$V_{IN} = 0.4\text{ dB below } f_S \text{ at } 1\text{ kHz, } V_{ref} = 5\text{ V}$		93.8		dB
		$V_{IN} = 0.4\text{ dB below } f_S \text{ at } 10\text{ kHz, } V_{ref} = 5\text{ V}$		93.4		dB
SFDR	Spurious-free dynamic range	$V_{IN} = 0.4\text{ dB below } f_S \text{ at } 1\text{ kHz, } V_{ref} = 5\text{ V}$		113		dB
		$V_{IN} = 0.4\text{ dB below } f_S \text{ at } 10\text{ kHz, } V_{ref} = 5\text{ V}$		107		dB
	-3-dB small-signal bandwidth			15		MHz
EXTERNAL REFERENCE INPUT						
V_{ref}	Input range		2.25	4.096	$VA + 0.1$	V
	Reference input current ⁽⁷⁾	During conversion		75		μA
POWER-SUPPLY REQUIREMENTS						
Power-supply voltage	+VBD		2.375	3.3	5.5	V
	+VA		4.5	5	5.5	V
I_{CC}	Supply current	+VA 250-kHz sample rate		3.5	4.0	mA
P_{VA}	Power dissipation	+VA = 5 V, 250-kHz sample rate		17.5	20.0	mW
$I_{VA_{pd}}$	Device power-down current ⁽⁸⁾	+VA = 5 V		50	300	nA
LOGIC FAMILY CMOS						
V_{IH}	High-level input voltage	$I_{IH} = 5\text{ }\mu\text{A}$	$0.7 \times VBD$		$VBD + 0.3$	V
V_{IL}	Low-level input voltage	$I_{IL} = 5\text{ }\mu\text{A}$	-0.3		$0.3 \times VBD$	V
V_{OH}	High-level output voltage	$I_{OH} = 2\text{ TTL loads}$	$VBD - 0.3$		V_{BD}	V
V_{OL}	Low-level output voltage	$I_{OL} = 2\text{ TTL loads}$	0		0.4	V
TEMPERATURE RANGE						
T_A	Operating free-air temperature		-40		85	$^{\circ}\text{C}$

(6) Calculated on the first nine harmonics of the input frequency.

(7) Can vary by $\pm 20\%$.

(8) The device automatically enters a power-down state at the end of every conversion and remains in a power-down state as long as the device is in an acquisition phase.

7.6 Timing Requirements

All specifications are at $T_A = -40^{\circ}\text{C}$ to 85°C , $+V_A = 5\text{ V}$, and $5.5\text{ V} > +V_{BD} \geq 2.375\text{ V}$, unless otherwise noted.

PARAMETER		TEST CONDITIONS	MIN	TYP	MAX	UNIT
SAMPLING AND CONVERSION						
t_{acq}	Acquisition time (see Figure 47, Figure 49, Figure 50, Figure 53)		700			ns
t_{cnv}	Conversion time (see Figure 47, Figure 49, Figure 50, Figure 53)		500 ⁽¹⁾		3300	ns
t_{cyc}	Time between conversions (see Figure 47, Figure 49, Figure 50, Figure 53)		4000			ns
t_1	Pulse duration, CONVST high (see Figure 47, Figure 49)		10			ns
t_6	Pulse duration, CONVST low (see Figure 50, Figure 53, Figure 55)		20			ns
INPUTS AND OUTPUTS (I/O)						
t_{clk}	SCLK period (see Figure 47, Figure 49, Figure 50, Figure 53, Figure 55, Figure 57)		40.0			ns
t_{clkl}	SCLK low time (see Figure 47, Figure 49, Figure 50, Figure 53, Figure 55, Figure 57)		0.45		0.55	t_{clk}
t_{clkh}	SCLK high time (see Figure 47, Figure 49, Figure 50, Figure 53, Figure 55, Figure 57)		0.45		0.55	t_{clk}
t_2	SCLK falling edge to data remains valid (see Figure 47, Figure 49, Figure 50, Figure 53, Figure 55, Figure 57)		5			ns
t_3	SCLK falling edge to next data valid delay (see Figure 47, Figure 49, Figure 50, Figure 53, Figure 55, Figure 57)	$5.5\text{ V} \geq +V_{BD} \geq 4.5\text{ V}$			16	ns
		$4.5\text{ V} > +V_{BD} \geq 2.375\text{ V}$			24	ns
t_{en}	CONVST or SDI low to MSB valid (see Figure 47, Figure 50)	$5.5\text{ V} \geq +V_{BD} \geq 4.5\text{ V}$			15	ns
		$4.5\text{ V} > +V_{BD} \geq 2.375\text{ V}$			22	ns
t_{dis}	CONVST or SDI high or last SCLK falling edge to SDO 3-state ($\overline{\text{CS}}$ mode) (see Figure 47, Figure 49, Figure 50, Figure 53)	$5.5\text{ V} \geq +V_{BD} \geq 4.5\text{ V}$			12	ns
		$4.5\text{ V} > +V_{BD} \geq 2.375\text{ V}$			15	ns
t_4	SDI valid setup time to CONVST rising edge (see Figure 50, Figure 53)		5			ns
t_5	SDI valid hold time from CONVST rising edge (see Figure 50, Figure 53)		5			ns
t_7	SCLK valid setup time to CONVST rising edge (see Figure 55)		5			ns
t_8	SCLK valid hold time from CONVST rising edge (see Figure 55)		5			ns

(1) Refer to the [\$\overline{\text{CS}}\$ Mode for a 3-Wire Interface](#) subsection in the [Device Functional Modes](#) section.

7.7 Typical Characteristics

At $T_A = 30^\circ\text{C}$, $+V_A = 5\text{ V}$, $+V_{BD} = 2.7\text{ V}$, $V_{ref} = 4.096\text{ V}$, and $f_{sample} = 250\text{ kHz}$, unless otherwise noted.

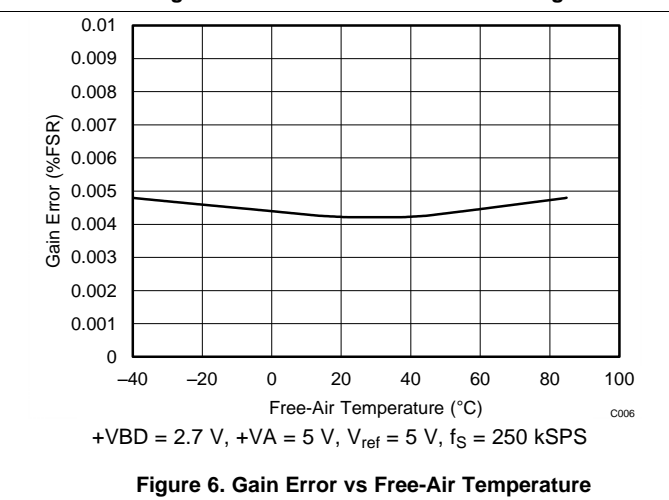
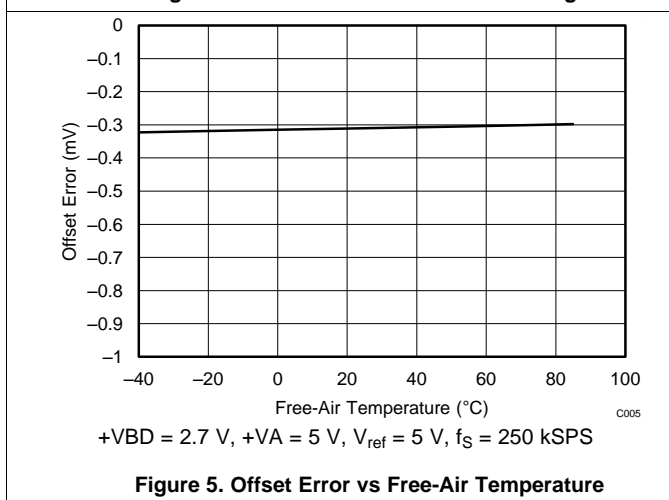
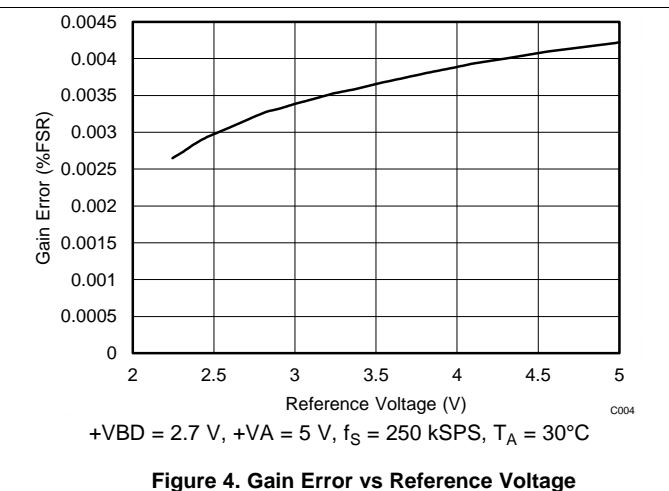
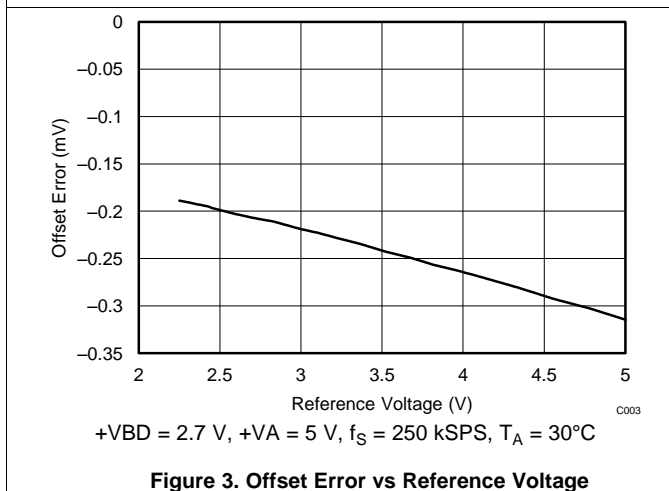
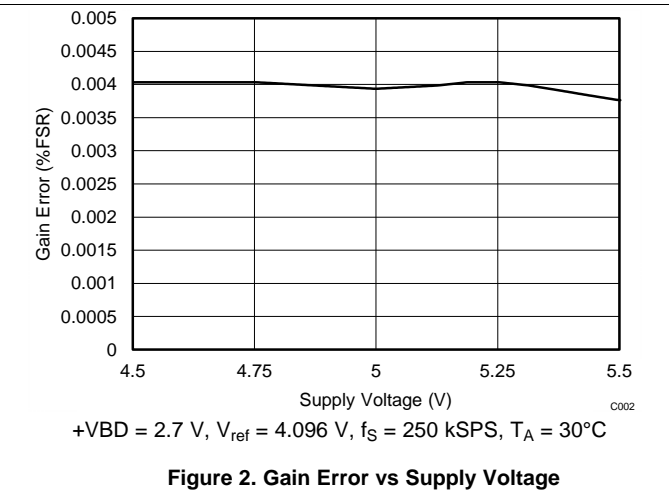
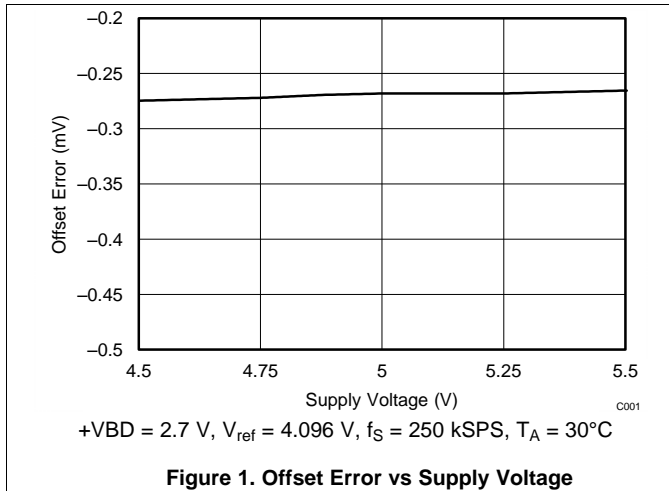

Typical Characteristics (continued)

At $T_A = 30^\circ\text{C}$, $+V_A = 5\text{ V}$, $+V_{BD} = 2.7\text{ V}$, $V_{ref} = 4.096\text{ V}$, and $f_{sample} = 250\text{ kHz}$, unless otherwise noted.

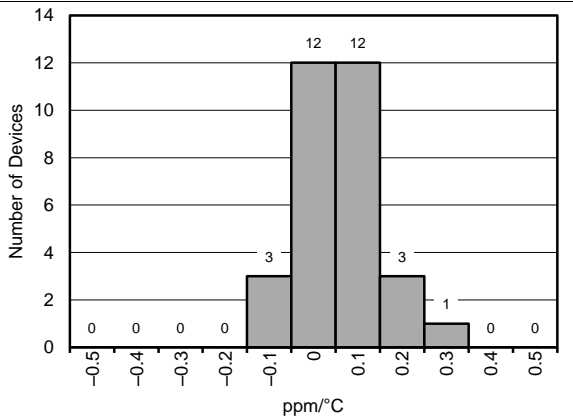

+VBD = 2.7 V, +VA = 5 V, $f_S = 250\text{ kSPS}$

Figure 7. Gain Error Drift Histogram

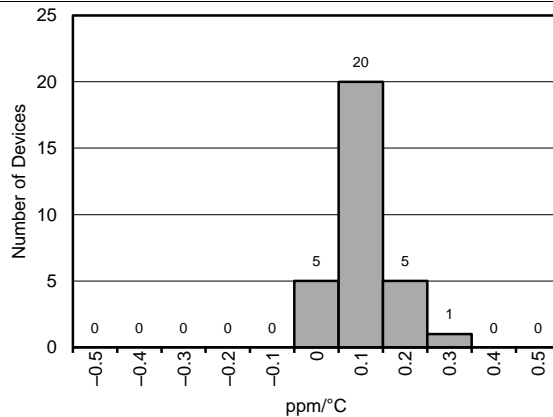

+VBD = 2.7 V, +VA = 5 V, $V_{ref} = 5\text{ V}$, $f_S = 250\text{ kSPS}$

Figure 8. Offset Error Drift Histogram

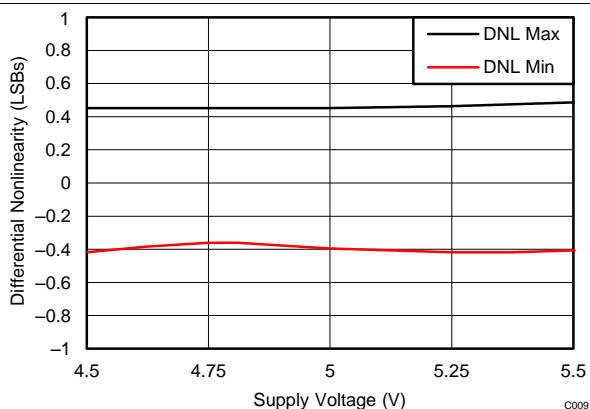

+VBD = 2.7 V, $V_{ref} = 4.096\text{ V}$, $f_S = 250\text{ kSPS}$, $T_A = 30^\circ\text{C}$

Figure 9. DNL vs Supply Voltage

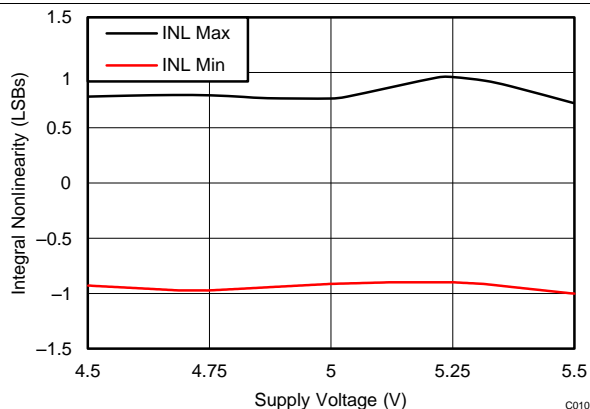

+VBD = 2.7 V, $V_{ref} = 4.096\text{ V}$, $f_S = 250\text{ kSPS}$, $T_A = 30^\circ\text{C}$

Figure 10. INL vs Supply Voltage

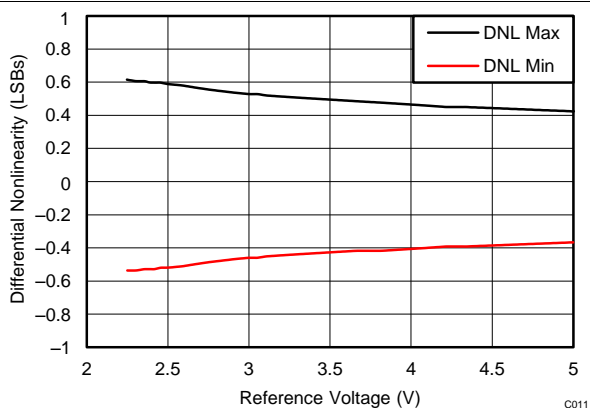

+VBD = 2.7 V, +VA = 5 V, $f_S = 250\text{ kSPS}$, $T_A = 30^\circ\text{C}$

Figure 11. DNL vs Reference Voltage

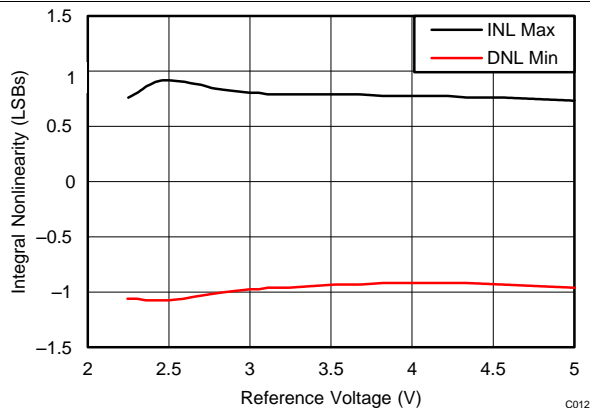

+VBD = 2.7 V, +VA = 5 V, $f_S = 250\text{ kSPS}$, $T_A = 30^\circ\text{C}$

Figure 12. INL vs Reference Voltage

Typical Characteristics (continued)

At $T_A = 30^\circ\text{C}$, $+V_A = 5\text{ V}$, $+V_{BD} = 2.7\text{ V}$, $V_{ref} = 4.096\text{ V}$, and $f_{sample} = 250\text{ kHz}$, unless otherwise noted.

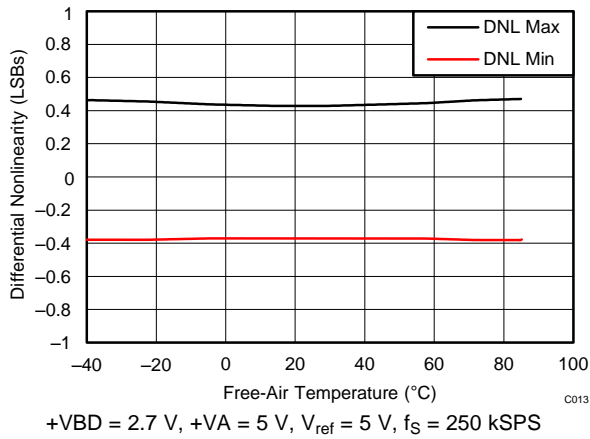

Figure 13. DNL vs Free-Air Temperature

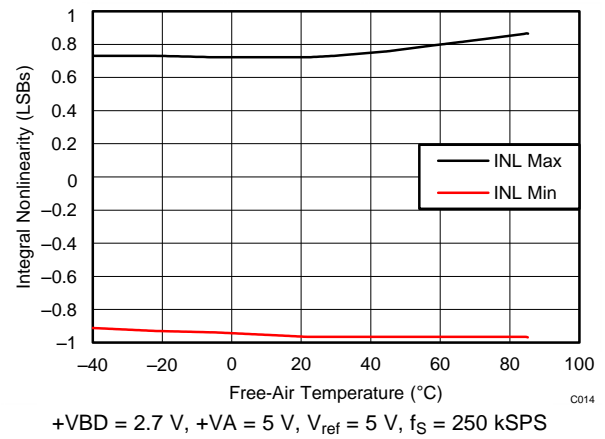

Figure 14. INL vs Free-Air Temperature

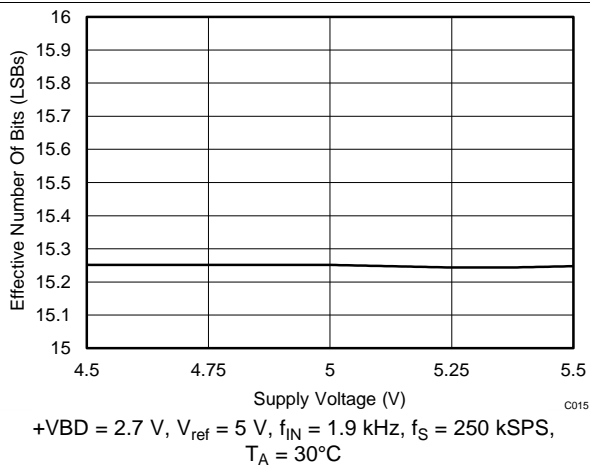

Figure 15. ENOB vs Supply Voltage

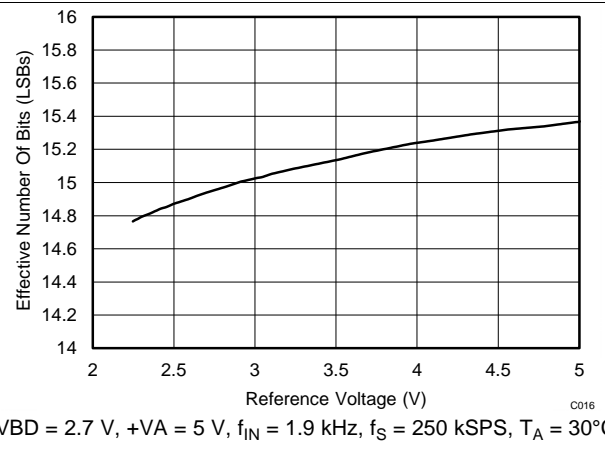

Figure 16. ENOB vs Reference Voltage

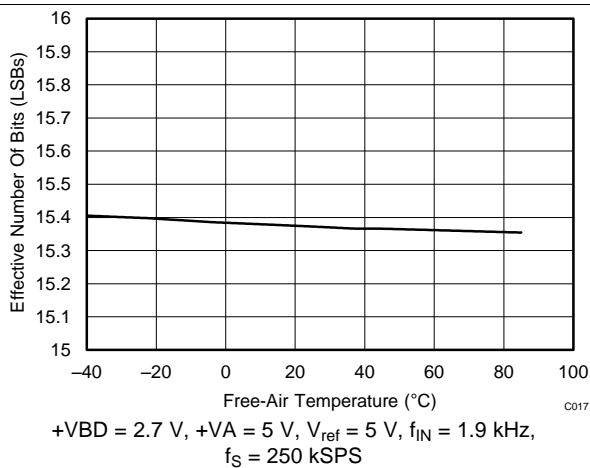

Figure 17. ENOB vs Free-Air Temperature

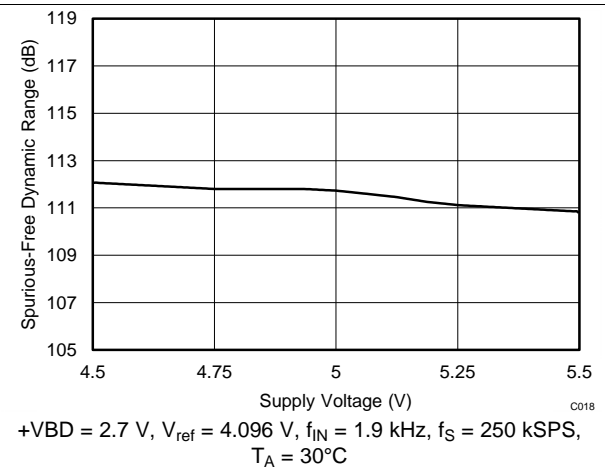
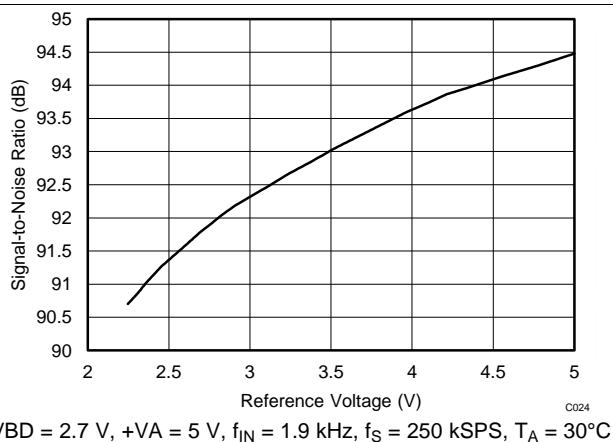
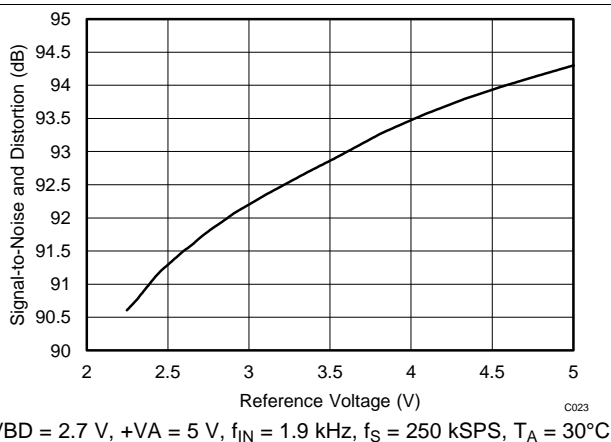
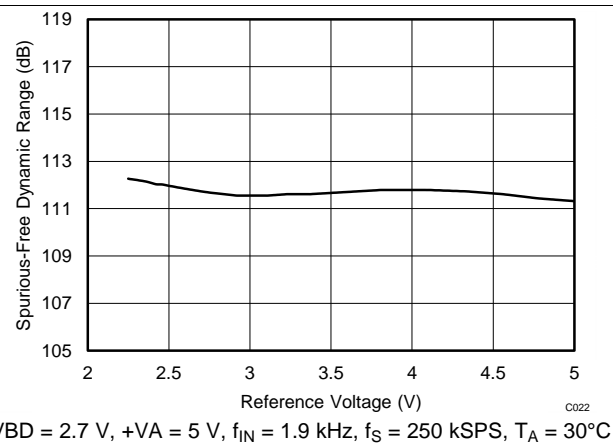
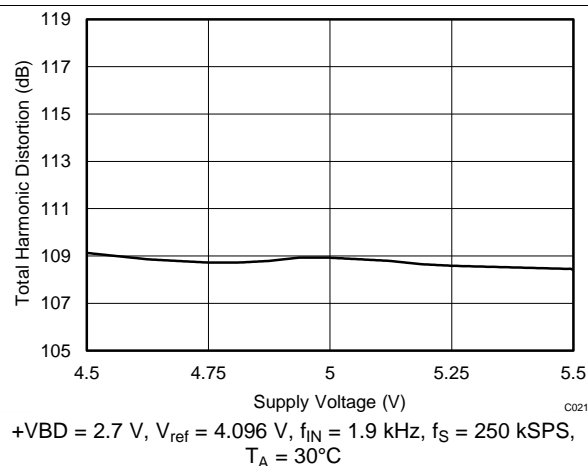
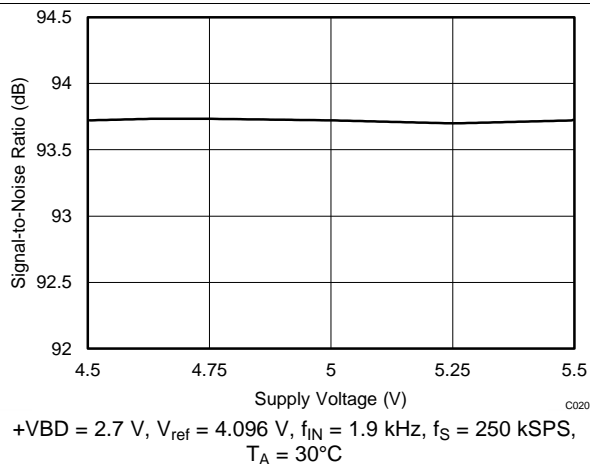
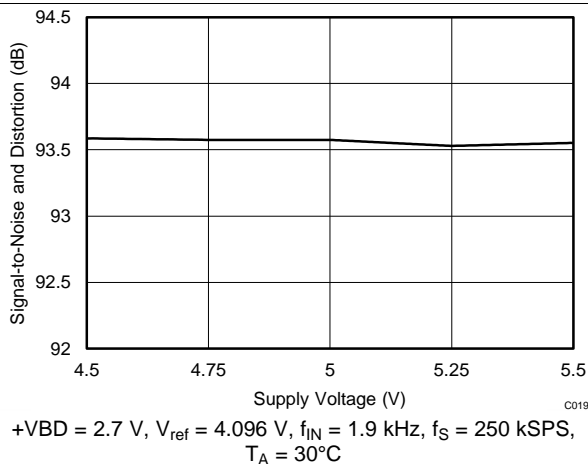

Figure 18. SFDR vs Supply Voltage

Typical Characteristics (continued)

At $T_A = 30^\circ\text{C}$, $+V_A = 5\text{ V}$, $+V_{BD} = 2.7\text{ V}$, $V_{ref} = 4.096\text{ V}$, and $f_{sample} = 250\text{ kHz}$, unless otherwise noted.



Typical Characteristics (continued)

At $T_A = 30^\circ\text{C}$, $+V_A = 5\text{ V}$, $+V_{BD} = 2.7\text{ V}$, $V_{ref} = 4.096\text{ V}$, and $f_{sample} = 250\text{ kHz}$, unless otherwise noted.

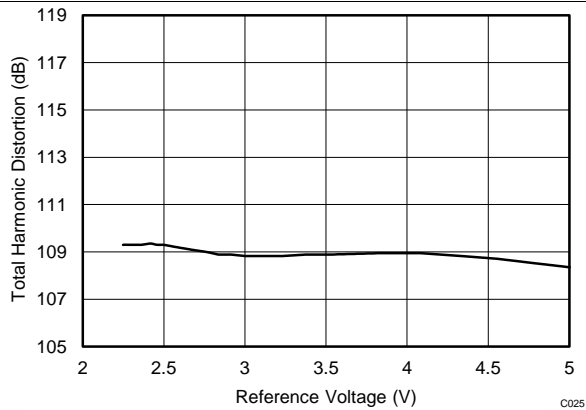

+VBD = 2.7 V, +VA = 5 V, $f_{IN} = 1.9\text{ kHz}$, $f_S = 250\text{ kSPS}$, $T_A = 30^\circ\text{C}$

Figure 25. THD vs Reference Voltage

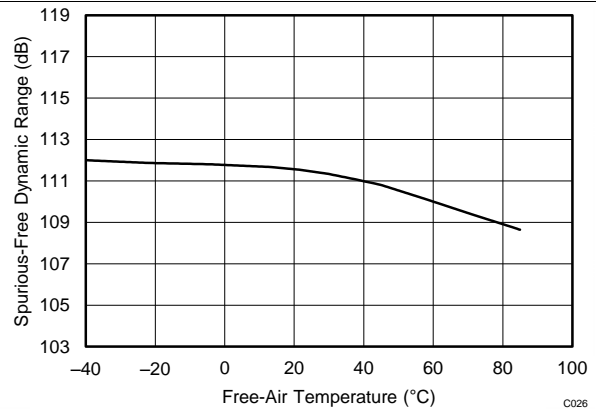

+VBD = 2.7 V, +VA = 5 V, $V_{ref} = 5\text{ V}$, $f_{IN} = 1.9\text{ kHz}$, $f_S = 250\text{ kSPS}$

Figure 26. SFDR vs Free-Air Temperature

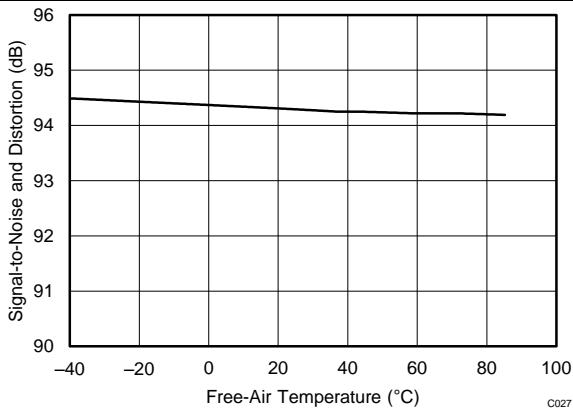

+VBD = 2.7 V, +VA = 5 V, $V_{ref} = 5\text{ V}$, $f_{IN} = 1.9\text{ kHz}$, $f_S = 250\text{ kSPS}$

Figure 27. SINAD vs Free-Air Temperature

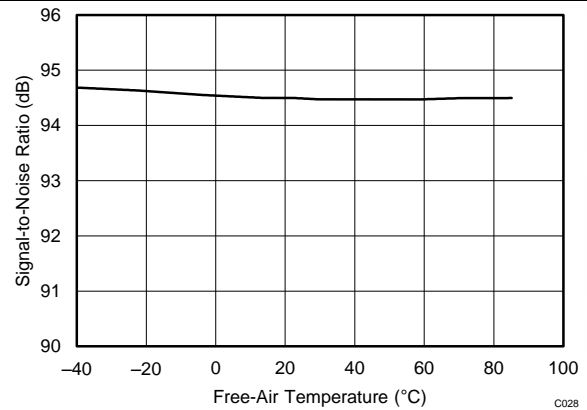

+VBD = 2.7 V, +VA = 5 V, $V_{ref} = 5\text{ V}$, $f_{IN} = 1.9\text{ kHz}$, $f_S = 250\text{ kSPS}$

Figure 28. SNR vs Free-Air Temperature

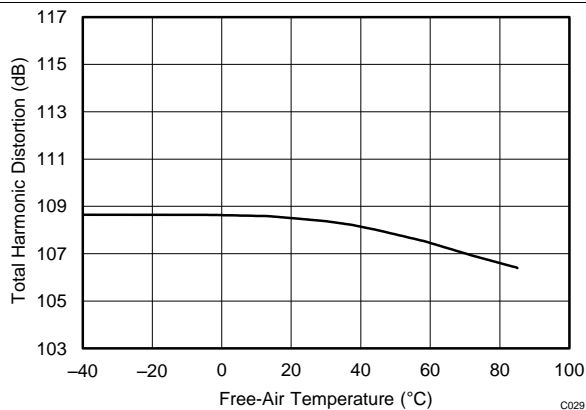

+VBD = 2.7 V, +VA = 5 V, $V_{ref} = 5\text{ V}$, $f_{IN} = 1.9\text{ kHz}$, $f_S = 250\text{ kSPS}$

Figure 29. THD vs Free-Air Temperature

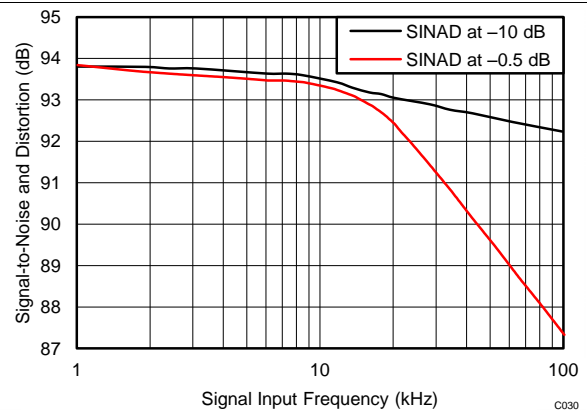

+VBD = 2.7 V, +VA = 5 V, $V_{ref} = 5\text{ V}$, $f_S = 250\text{ kSPS}$, $T_A = 30^\circ\text{C}$

Figure 30. SINAD vs Signal Input Frequency

Typical Characteristics (continued)

At $T_A = 30^\circ\text{C}$, $+V_A = 5\text{ V}$, $+V_{BD} = 2.7\text{ V}$, $V_{ref} = 4.096\text{ V}$, and $f_{sample} = 250\text{ kHz}$, unless otherwise noted.

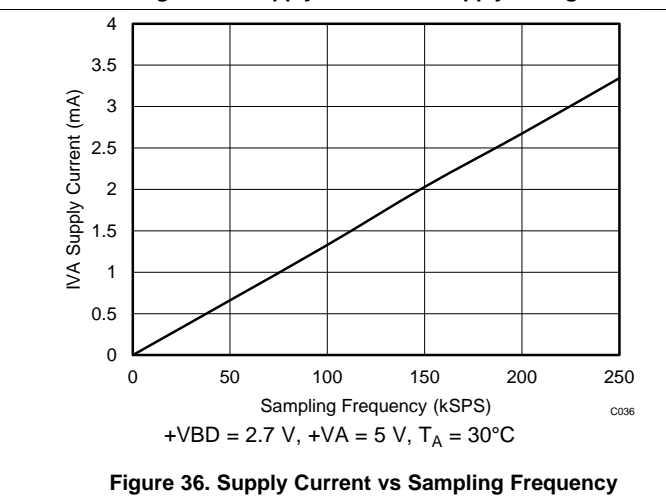
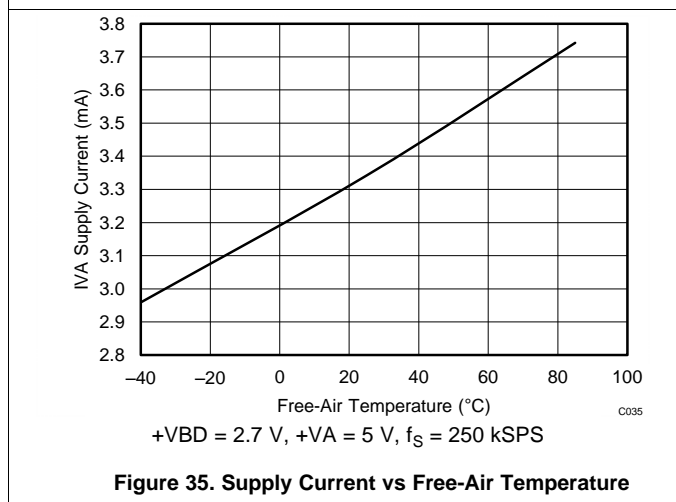
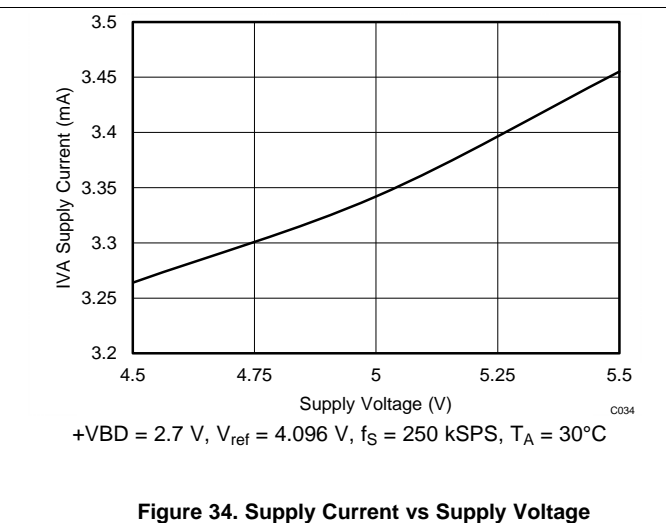
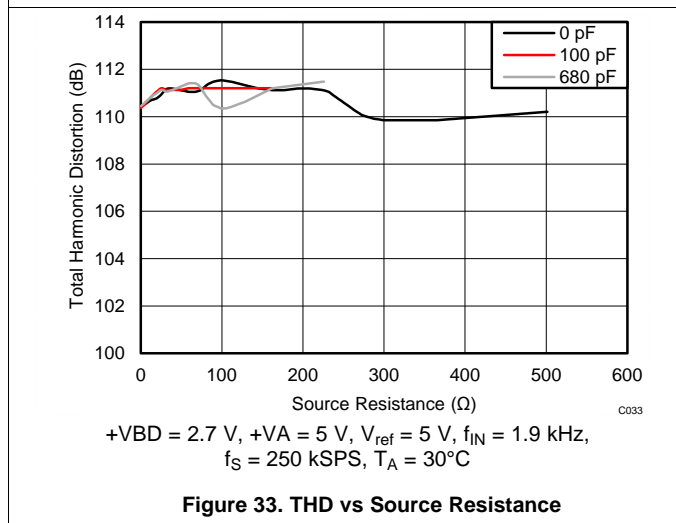
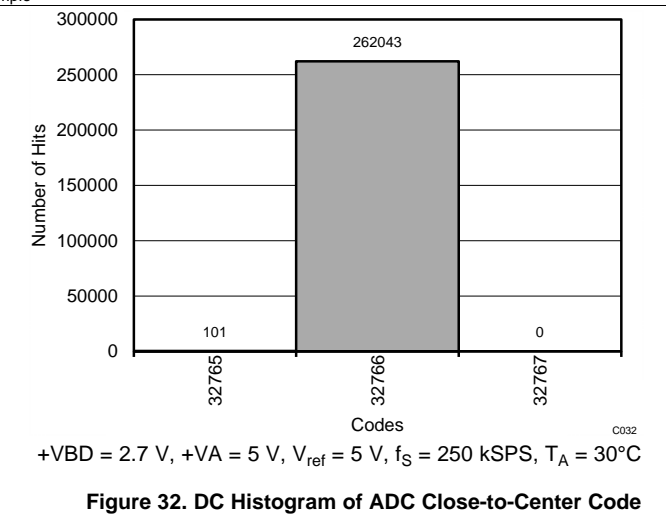
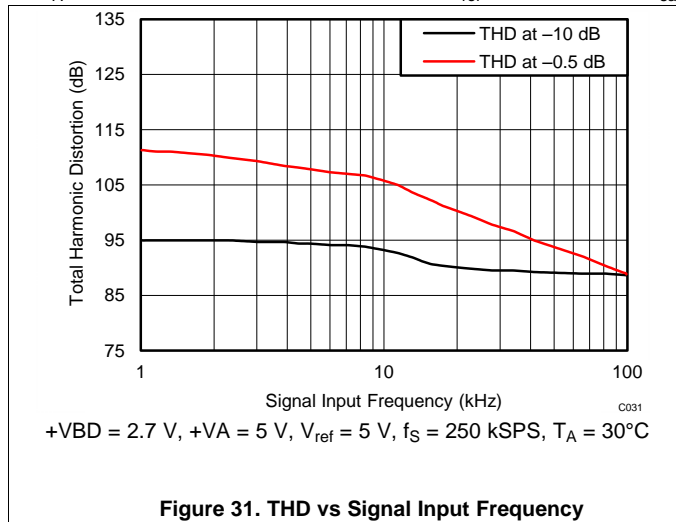

Typical Characteristics (continued)

At $T_A = 30^\circ\text{C}$, $+V_A = 5\text{ V}$, $+V_{BD} = 2.7\text{ V}$, $V_{ref} = 4.096\text{ V}$, and $f_{sample} = 250\text{ kHz}$, unless otherwise noted.

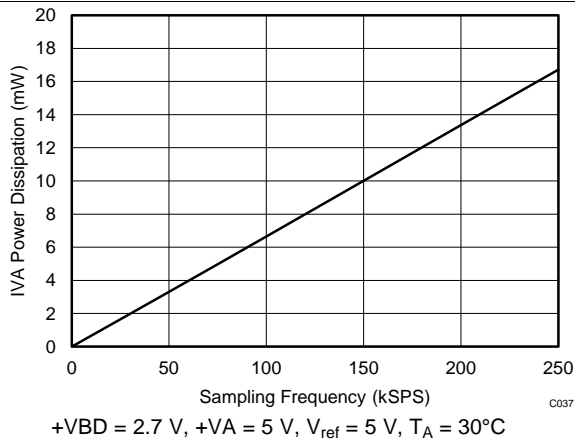

Figure 37. Power Dissipation vs Sampling Frequency

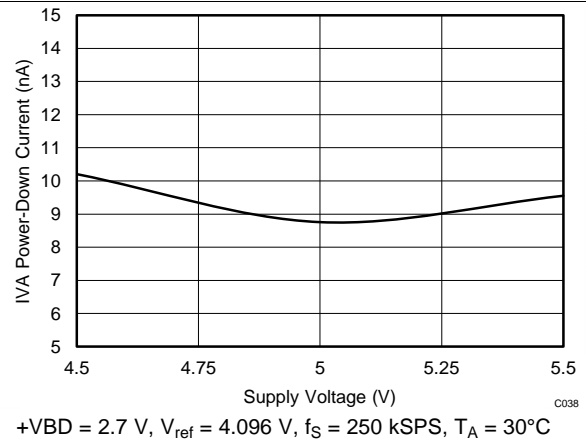

Figure 38. Power-Down Current vs Supply Voltage

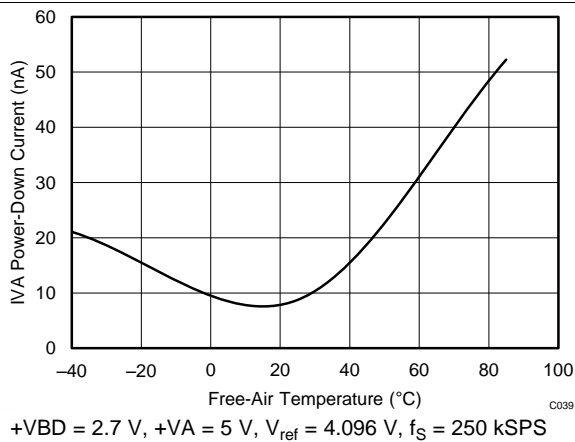

Figure 39. Power-Down Current vs Free-Air Temperature

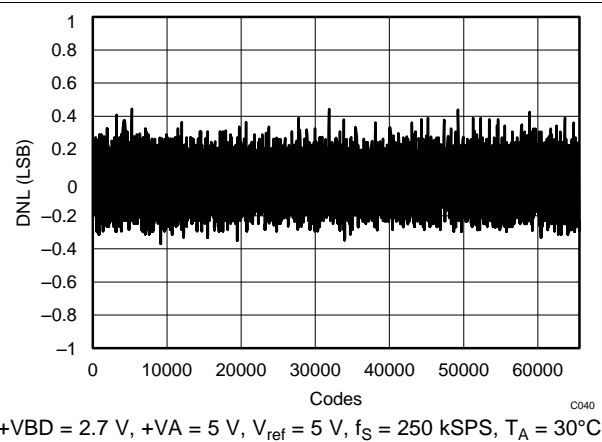

Figure 40. DNL Error vs Output Code

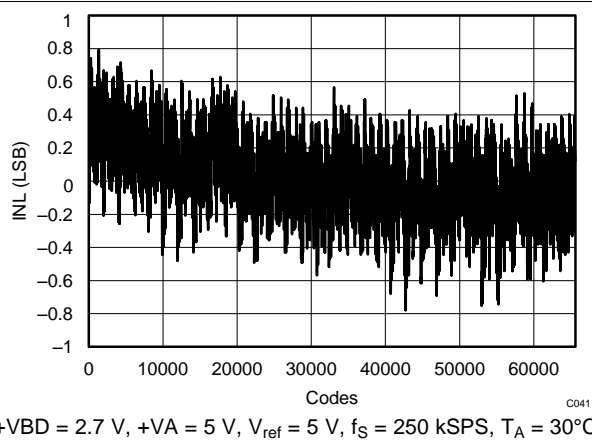

Figure 41. INL Error vs Output Code

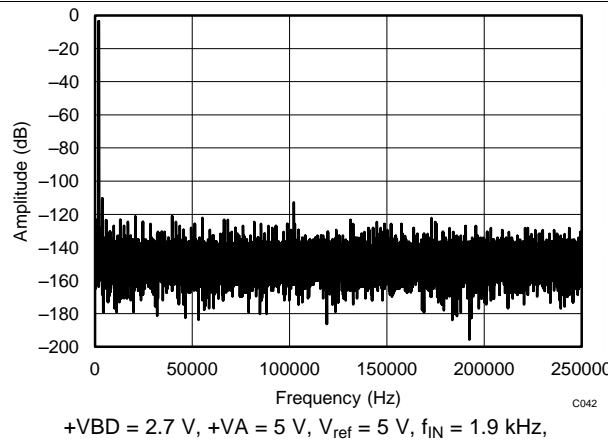

Figure 42. Signal Strength vs Frequency

8 Parametric Measurement Information

8.1 Timing Diagrams

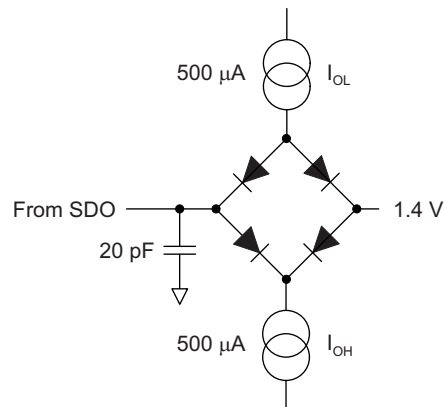

Figure 43. Digital Interface Timing Load Circuit

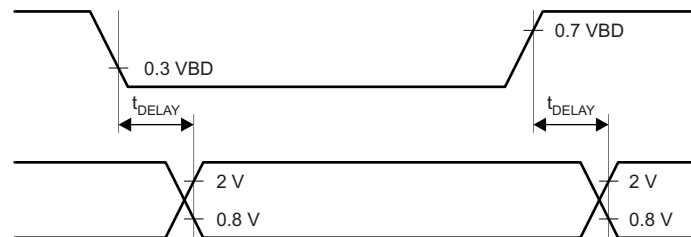

Figure 44. Timing Voltage Levels

9 Detailed Description

9.1 Overview

The ADS8339 is a 250-kSPS, low-power, successive-approximation register (SAR), analog-to-digital converter (ADC) that uses an external reference. The architecture is based on charge redistribution, which inherently includes a sample-and-hold function.

The ADS8339 is a single-channel device. The analog input is provided to two input pins: +IN and –IN, where –IN is a pseudo-differential input and has a limited range of ± 0.1 V. When a conversion is initiated, the differential input on these pins is sampled on the internal capacitor array. While a conversion is in progress, both the +IN and –IN inputs are disconnected from any internal functions.

The device has an internal clock that is used to run the conversion. Therefore, the conversion requires a fixed amount of time. After a conversion is completed, the device reconnects the sampling capacitors to the +IN and –IN pins and the device is in the acquisition phase. During this phase, the device is powered down and conversion data can be read.

The device digital output is available in SPI-compatible format. The device easily interfaces with microprocessors, digital signal processors (DSPs), or field-programmable gate arrays (FPGAs).

9.2 Functional Block Diagram

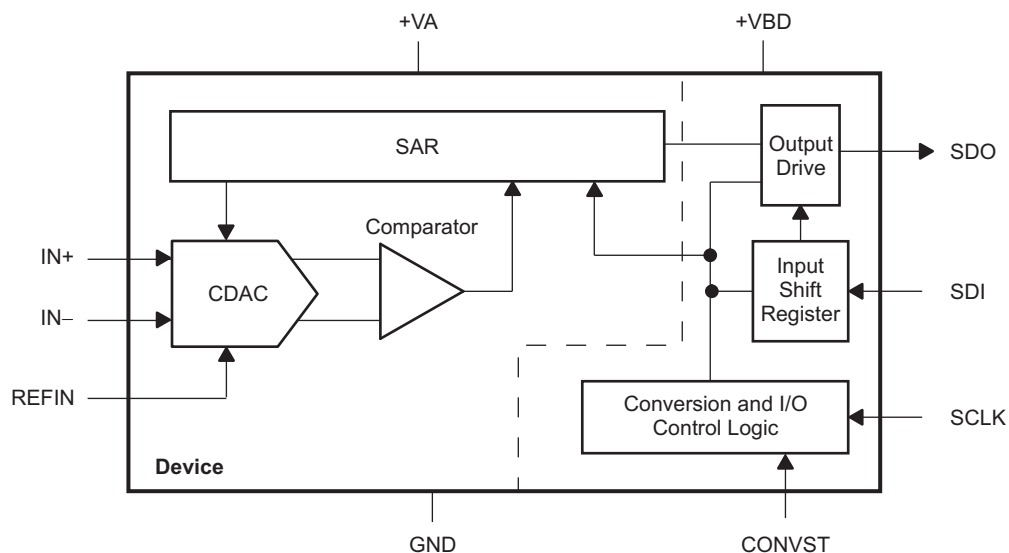

9.3 Feature Description

9.3.1 Analog Input

When the converter samples the input, the voltage difference between the +IN and –IN inputs is captured on the internal capacitor array. The differential signal range is $[(+IN) - (-IN)]$. The voltage on +IN is limited between $GND - 0.1 V$ and $V_{ref} + 0.1 V$ and the voltage on –IN is limited between $GND - 0.1 V$ to $GND + 0.1 V$. The input rejects any small signal that is common to both the +IN and –IN input.

The (peak) input current through the analog input depends upon a number of factors: sample rate, input voltage, and source impedance. The current into the device charges the internal capacitor array (as shown in Figure 45) during the sample period. When this capacitance is fully charged, there is no further input current. The source of the analog input voltage must be able to charge the input capacitance (59 pF) to a 18-bit settling level within the minimum acquisition time. When the converter goes into hold mode, the input impedance is greater than 1 GΩ.

Care must be taken regarding the absolute analog input voltage. To maintain linearity of the converter, the +IN input, –IN input, and span $[+IN - (-IN)]$ must be within the limits specified. Outside of these ranges, the converter linearity may not meet specifications.

Care must also be taken to ensure that the output impedance of the sources driving the +IN input and the –IN input is matched. If this output impedance is not well matched, the two inputs can have different settling times. This mismatch may result in an offset error, gain error, and linearity error that changes with temperature and input voltage. Typically, the –IN input is grounded at the input decoupling capacitor.

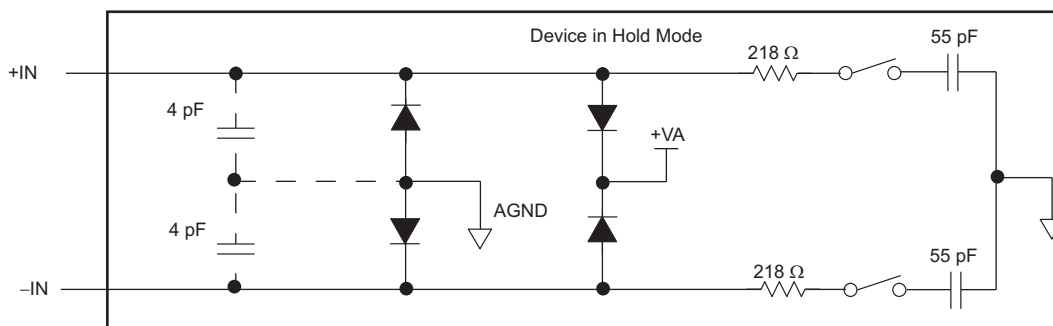

Figure 45. Input Equivalent Circuit

9.3.2 Power Saving

The device has an auto power-down feature. The device powers down at the end of every conversion. The input signal is acquired on sampling capacitors when the device is in power-down state. At the same time, the conversion results are available for reading. The device powers up automatically at the start of the conversion. The conversion runs on an internal clock and requires a fixed time. As a result, device power consumption is directly proportional to the speed of operation.

Feature Description (continued)

9.3.3 Digital Output

As discussed in the [Description](#) and [Timing Diagrams](#) sections, the device digital output is SPI-compatible. [Table 1](#) lists the output codes corresponding to various analog input voltages.

Table 1. Output Codes

DESCRIPTION	ANALOG VALUE (V)	DIGITAL OUTPUT STRAIGHT BINARY	
		BINARY CODE	HEX CODE
Full-scale range	V_{ref}	—	—
Least significant bit (LSB)	$V_{ref} / 65536$	—	—
Positive full-scale	$+V_{ref} - 1 \text{ LSB}$	1111 1111 1111 1111	FFFF
Mid-scale	$V_{ref} / 2$	1000 0000 0000 0000	8000
Mid-scale – 1 LSB	$V_{ref} / 2 - 1 \text{ LSB}$	0111 1111 1111 1111	7FFF
Zero	0	0000 0000 0000 0000	0000

9.3.4 SCLK Input

The device uses SCLK for the serial data output. Data are read after the conversion is complete and the device is in acquisition phase. A free-running SCLK can be used, but TI recommends stopping the clock during conversion time because the clock edges can couple with the internal analog circuit that, in turn, can affect the conversion results.

9.4 Device Functional Modes

The ADS8339 supports three interface options. Under each option, the device can be used with or without a busy indicator.

1. \overline{CS} mode for a 3-wire interface (with or without a busy indicator): This mode is useful for applications where a single ADS8339 device is connected to the digital host.
2. \overline{CS} mode for a 4-wire interface (with or without a busy indicator): This mode can be used when more than one ADS8339 device is connected to the digital host on a common data bus.
3. Daisy-chain mode (with or without a busy indicator): This mode is provided to connect multiple ADS8339 devices in a chain (such as a shift register) and is useful when reducing the number of signal traces on the board or the component count.

The busy indicator is generated as the bit preceding the 16-bit serial data.

Device Functional Modes (continued)

9.4.1 $\overline{\text{CS}}$ Mode for a 3-Wire Interface

$\overline{\text{CS}}$ mode is selected if SDI is high at the CONVST rising edge. As previously indicated, the device can be used without or with a busy indicator. This section discusses this interface and the two options in detail.

9.4.1.1 3-Wire $\overline{\text{CS}}$ Mode Without a Busy Indicator

In a 3-wire $\overline{\text{CS}}$ mode, SDI is permanently tied to +VBD, as shown in Figure 46. CONVST functions like $\overline{\text{CS}}$. As shown in Figure 47, the device samples the input signal and enters the conversion phase on the CONVST rising edge. SDO goes to 3-state at the same time. Conversion is done with the internal clock and continues regardless of the state of CONVST. As a result, CONVST (functioning as $\overline{\text{CS}}$) can be brought low after the start of the conversion to select other devices on the board.

CONVST must return to high before the minimum conversion time ($t_{\text{cnv_min}}$ in the [Timing Requirements](#) table) elapses. A high level on CONVST at the end of the conversion ensures the device does not generate a busy indicator.

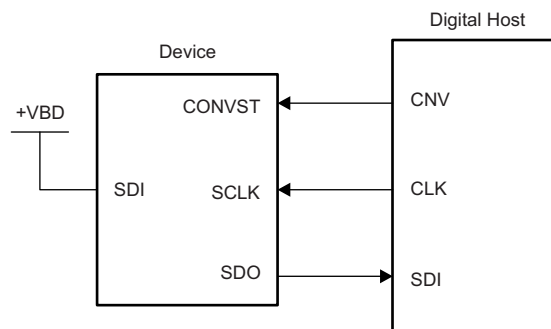

Figure 46. Connection Diagram: 3-Wire $\overline{\text{CS}}$ Mode without a Busy Indicator (SDI = 1)

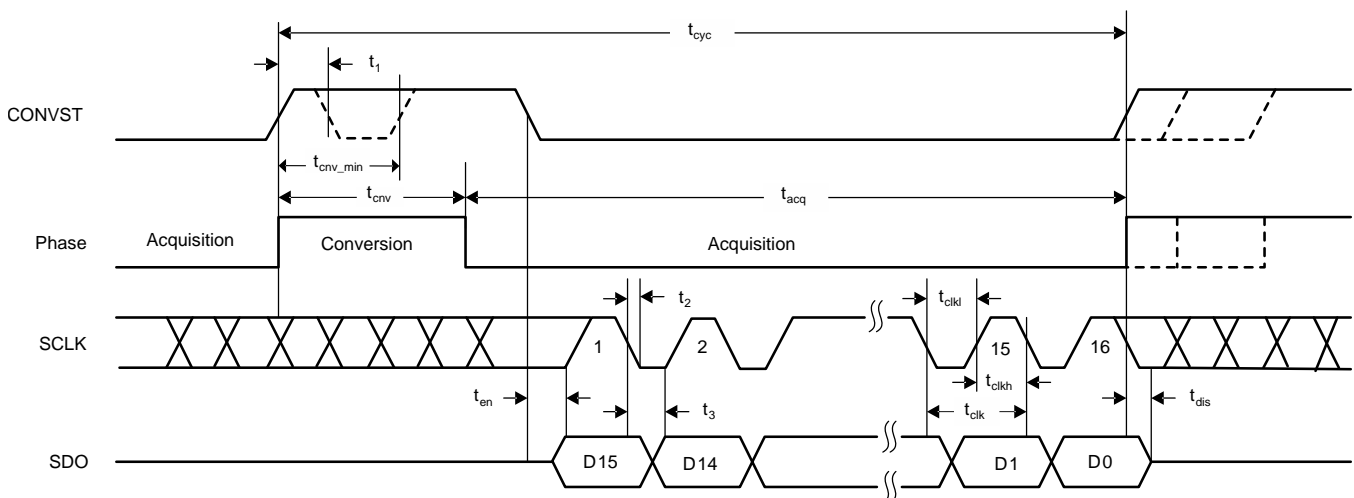

Figure 47. Interface Timing Diagram: 3-Wire $\overline{\text{CS}}$ Mode Without a Busy Indicator (SDI = 1)

When the conversion is complete, the device enters acquisition phase and powers down. On the CONVST falling edge, SDO comes out of 3-state and the device outputs the MSB of the data. Afterwards, the device outputs the next lower data bits on every subsequent SCLK falling edge. A minimum of 15 SCLK falling edges must occur during the low period of CONVST. SDO goes to 3-state after the 16th SCLK falling edge or when CONVST is high, whichever occurs first.

Device Functional Modes (continued)

9.4.1.2 3-Wire $\overline{\text{CS}}$ Mode With a Busy Indicator

As stated in the [3-Wire \$\overline{\text{CS}}\$ Mode Without a Busy Indicator](#) section, SDI is permanently tied to +VBD, as shown in [Figure 48](#). CONVST functions like $\overline{\text{CS}}$. As shown in [Figure 49](#), the device samples the input signal and enters the conversion phase on the CONVST rising edge. SDO goes to 3-state at the same time. Conversion is done with the internal clock and continues regardless of the state of CONVST. As a result, CONVST (functioning as $\overline{\text{CS}}$) can be toggled after the start of the conversion to select other devices on the board.

CONVST must return to low before the minimum conversion time ($t_{\text{cnv_min}}$ in the [Timing Requirements](#) table) elapses and remains low until the end of the maximum conversion time. A low level on the CONVST input at the end of a conversion ensures the device generates a busy indicator (low level on SDO). For fast settling, a 10-k Ω pull-up resistor tied to +VBD is recommended to provide the necessary current to drive SDO low.

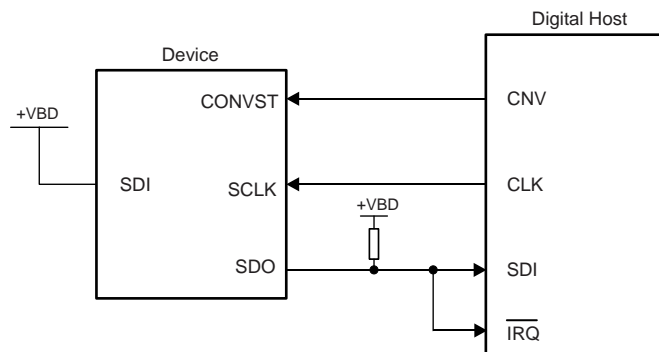

Figure 48. Connection Diagram: 3-Wire $\overline{\text{CS}}$ Mode With a Busy Indicator

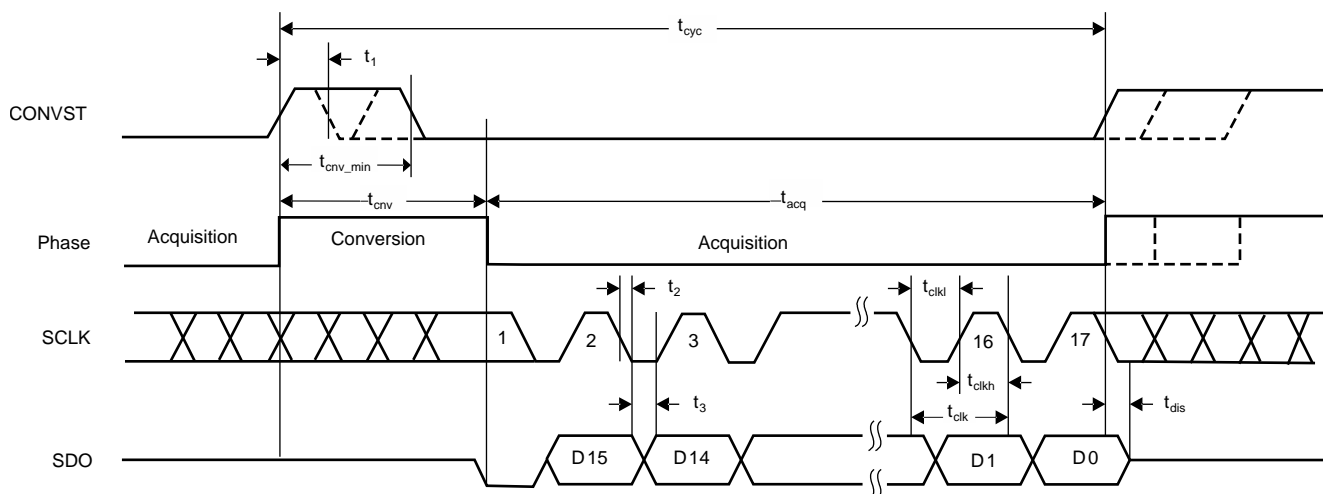

Figure 49. Interface Timing Diagram: 3-Wire $\overline{\text{CS}}$ Mode With a Busy Indicator (SDI = 1)

When the conversion is complete, the device enters acquisition phase, powers down, forces SDO out of 3-state, and outputs a busy indicator bit (low level). The device outputs the MSB of data on the first SCLK falling edge after the conversion is complete and continues to output the next lower data bits on every subsequent SCLK falling edge. A minimum of 16 SCLK falling edges must occur during the low period of CONVST. SDO goes to 3-state after the 17th SCLK falling edge or when CONVST is high, whichever occurs first.

Device Functional Modes (continued)

9.4.2 $\overline{\text{CS}}$ Mode for a 4-Wire Interface

This interface is similar to the $\overline{\text{CS}}$ mode for 3-wire interface except that SDI is controlled by the digital host. This section discusses in detail the interface option with and without a busy indicator.

9.4.2.1 4-Wire $\overline{\text{CS}}$ Mode Without a Busy Indicator

As mentioned previously, in order to select $\overline{\text{CS}}$ mode, SDI must be high at the time of the CONVST rising edge. Unlike in the 3-wire interface option, SDI is controlled by the digital host and functions like $\overline{\text{CS}}$. As shown in Figure 50, SDI goes to a high level before the CONVST rising edge. When SDI is high, the CONVST rising edge selects $\overline{\text{CS}}$ mode, forces SDO to 3-state, samples the input signal, and the device enters the conversion phase.

In the 4-wire interface option, CONVST must be at a high level from the start of the conversion until all data bits are read. Conversion is done with the internal clock and continues regardless of the state of SDI. As a result, SDI (functioning as $\overline{\text{CS}}$) can be brought low to select other devices on the board.

SDI must return to high before the minimum conversion time ($t_{\text{cnv_min}}$ in the *Timing Requirements* table) elapses.

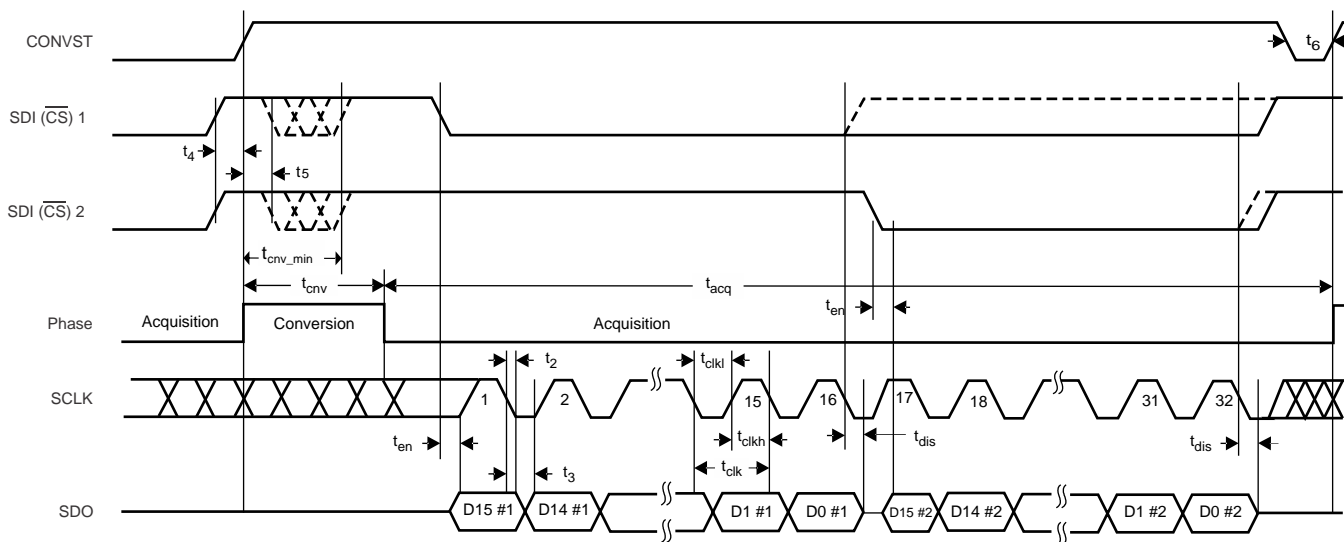

Figure 50. Interface Timing Diagram: 4-Wire $\overline{\text{CS}}$ Mode Without a Busy Indicator

Device Functional Modes (continued)

When the conversion is complete, the device enters the acquisition phase and powers down. An SDI falling edge can occur after the maximum conversion time (t_{cnv} in the [Timing Requirements](#) table). Note that SDI must be high at the end of the conversion so that the device does not generate a busy indicator. The SDI falling edge brings SDO out of 3-state and the device outputs the MSB of the data. Subsequently, the device outputs the next lower data bits on every subsequent SCLK falling edge. SDO goes to 3-state after the 16th SCLK falling edge or when SDI (\overline{CS}) is high, whichever occurs first. As shown in [Figure 51](#), multiple devices can be chained on the same data bus. In this case, the second device SDI (functioning as \overline{CS}) can go low after the first device data are read and the device 1 SDO is in 3-state.

Care must be taken so that CONVST and SDI are not both low at any time during the cycle.

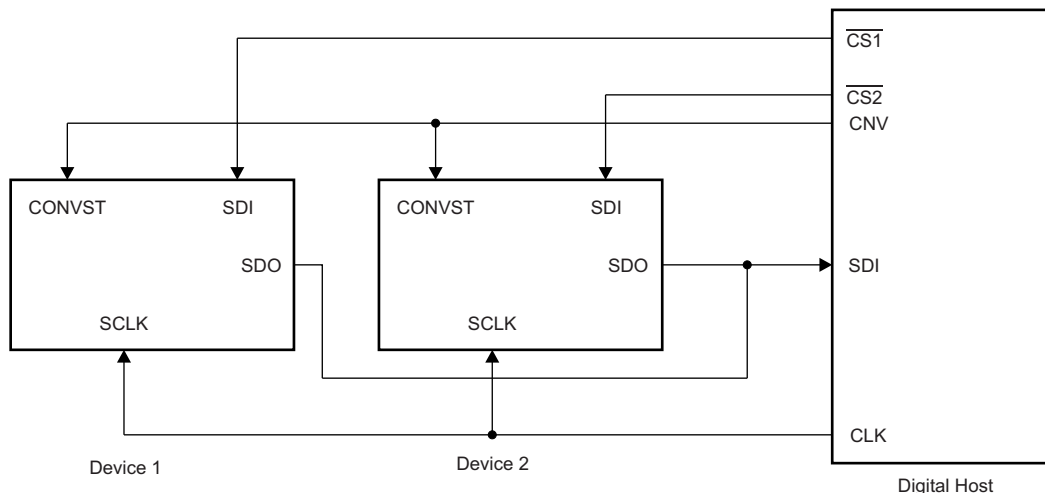

Figure 51. Connection Diagram: 4-Wire \overline{CS} Mode Without a Busy Indicator

9.4.2.2 4-Wire \overline{CS} Mode With a Busy Indicator

As mentioned previously, in order to select \overline{CS} mode, SDI must be high at the time of the CONVST rising edge. In this mode of operation, the connection is made as shown in [Figure 52](#).

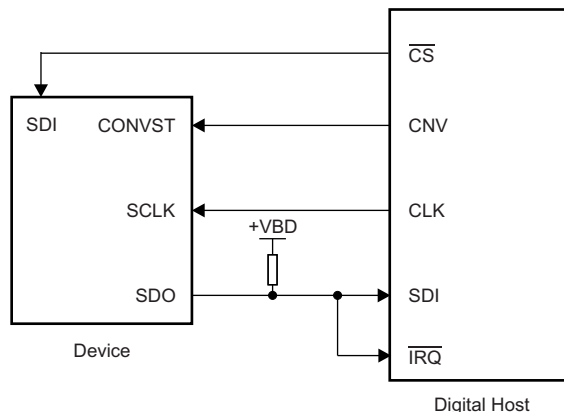

Figure 52. Connection Diagram: 4-Wire \overline{CS} Mode With a Busy Indicator

Device Functional Modes (continued)

Unlike in the 3-wire interface option, SDI is controlled by the digital host and functions like $\overline{\text{CS}}$. As shown in Figure 53, SDI goes to a high level before the CONVST rising edge. When SDI is high, the CONVST rising edge selects the $\overline{\text{CS}}$ mode, forces SDO to 3-state, samples the input signal, and the device enters the conversion phase.

In the 4-wire interface option, CONVST must be at a high level from the start of the conversion until all data bits are read. Conversion is done with the internal clock and continues regardless of the state of SDI. As a result, SDI (functioning as $\overline{\text{CS}}$) can be toggled to select other devices on the board.

SDI must return low before the minimum conversion time ($t_{\text{cnv_min}}$ in the *Timing Requirements* table) elapses and must remain low until the end of the maximum conversion time. A low level on the SDI input at the end of a conversion ensures the device generates a busy indicator (low on SDO). For fast settling, a 10-k Ω pull-up resistor tied to +VBD is recommended to provide the necessary current to drive SDO low.

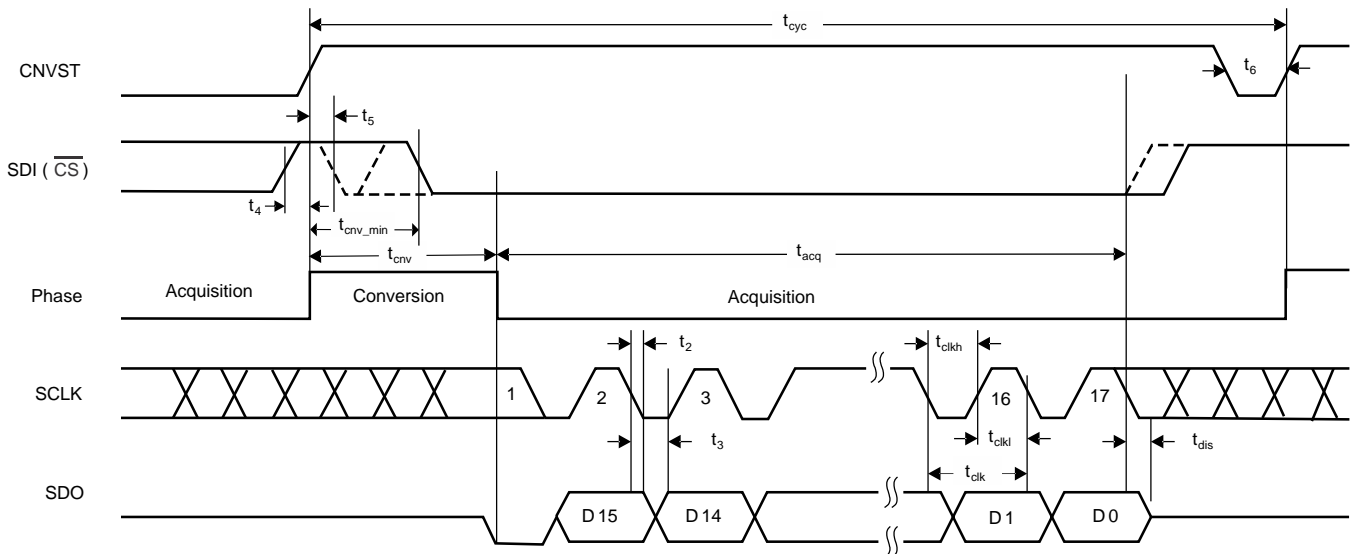

Figure 53. Interface Timing Diagram: 4-Wire $\overline{\text{CS}}$ Mode With a Busy Indicator

When the conversion is complete, the device enters acquisition phase, powers down, forces SDO out of 3-state, and outputs a busy indicator bit (low level). The device outputs the MSB of the data on the first SCLK falling edge after the conversion is complete and continues to output the next lower data bits on every subsequent SCLK falling edge. SDO goes to 3-state after the 17th SCLK falling edge or when SDI ($\overline{\text{CS}}$) is high, whichever occurs first.

Care must be taken so that CONVST and SDI are not both low at any time during the cycle.

9.4.3 Daisy-Chain Mode

Daisy-chain mode is selected if SDI is low at the time of the CONVST rising edge. This mode is useful to reduce wiring and hardware requirements (such as digital isolators in applications where multiple ADC devices are used). In this mode, all devices are connected in a chain (the SDO of one device is connected to the SDI of the next device) and data transfer is analogous to a shift register.

As in $\overline{\text{CS}}$ mode, this mode offers operation with or without a busy indicator. This section discusses these interface options in detail.

Device Functional Modes (continued)

9.4.3.1 Daisy-Chain Mode Without a Busy Indicator

A connection diagram for this mode is shown in [Figure 54](#). The SDI for device 1 is tied to ground and the SDO of device 1 goes to the SDI of device 2, and so on. The SDO of the last device in the chain goes to the digital host. CONVST for all devices in the chain are tied together. There is no CS signal in this mode.

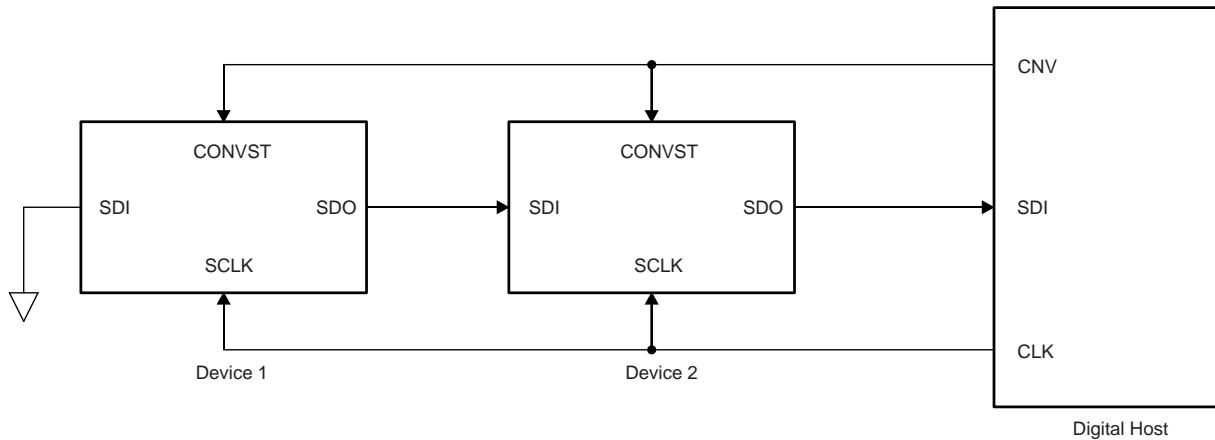

Figure 54. Connection Diagram: Daisy-Chain Mode Without a Busy Indicator (SDI = 0)

The device SDO is driven low when SDI low selects daisy-chain mode and the device samples the analog input and enters the conversion phase. SCLK must be low at the CONVST rising edge (as shown in [Figure 55](#)) so that the device does not generate a busy indicator at the end of the conversion. In this mode, CONVST remains high from the start of the conversion until all data bits are read. When started, the conversion continues regardless of the state of SCLK.

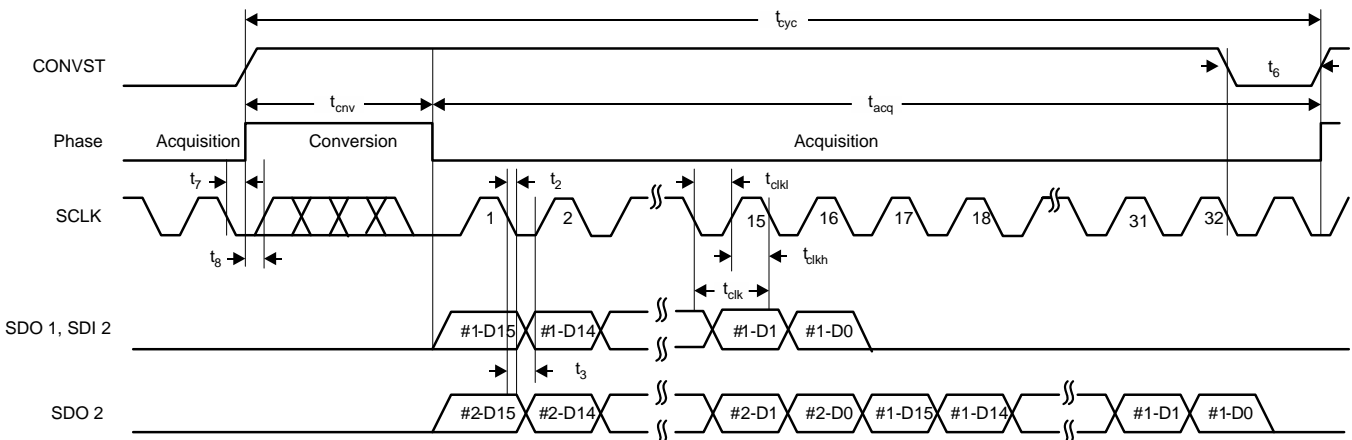

Figure 55. Interface Timing Diagram: Daisy-Chain Mode Without a Busy Indicator

At the end of the conversion, every device in the chain initiates an output of its conversion data starting with the MSB bit. Furthermore, the next lower data bit is output on every subsequent SCLK falling edge. While every device outputs its data on the SDO pin, each device also receives the previous device data on the SDI pin (other than device 1) and stores the data in the shift register. The device latches incoming data on every SCLK falling edge. The SDO of the first device in the chain goes low after the 16th SCLK falling edge. All subsequent devices in the chain output the stored data from the previous device in MSB-first format immediately following their own data word. 16 x N clocks must read data for N devices in the chain.

Device Functional Modes (continued)

9.4.3.2 Daisy-Chain Mode With a Busy Indicator

A connection diagram for this mode is shown in Figure 56. The SDI for device 1 is wired to its CONVST and the CONVST for all devices in the chain are wired together. The SDO of device 1 goes to the SDI of device 2, and so on. The SDO of the last device in the chain goes to the digital host. There is no CS signal in this mode.

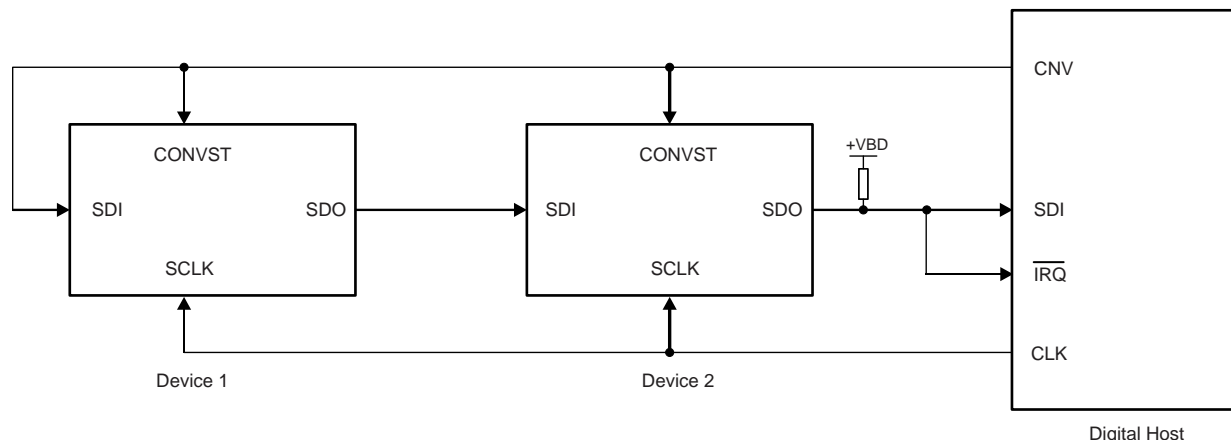

Figure 56. Connection Diagram: Daisy Chain Mode With a Busy Indicator (SDI = 0)

On the CONVST rising edge, all devices in the chain sample the analog input and enter the conversion phase. For the first device, SDI and CONVST are wired together and the setup time of SDI to the CONVST rising edge is adjusted so that the device still enters daisy-chain mode even though SDI and CONVST rise together. SCLK must be high at the CONVST rising edge (as shown in Figure 57) so that the device generates a busy indicator at the end of the conversion. In this mode, CONVST remains high from the start of the conversion until all data bits are read. When started, the conversion continues regardless of the state of SCLK.

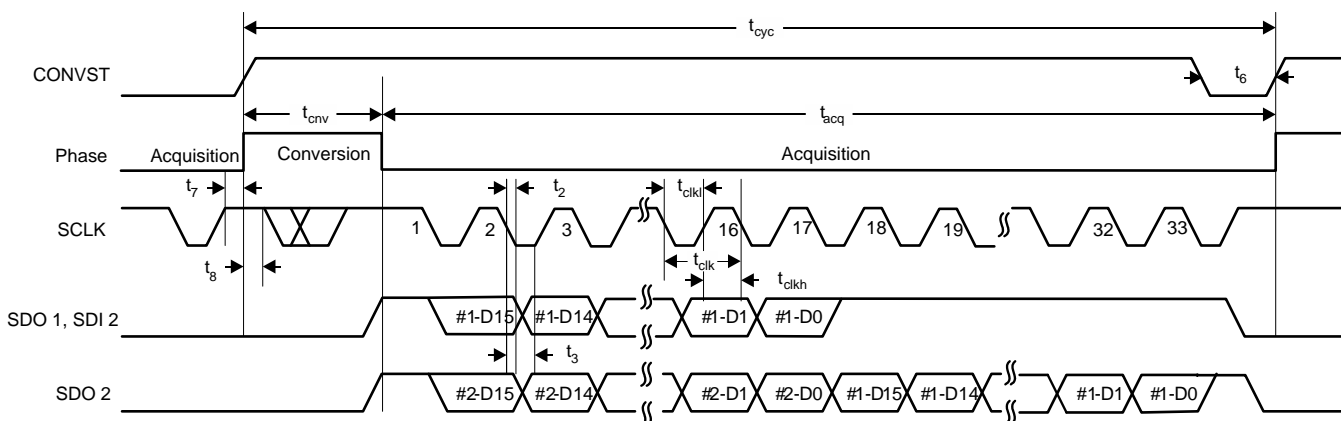

Figure 57. Interface Timing Diagram: Daisy Chain Mode With a Busy Indicator

At the end of the conversion, all devices in the chain generate busy indicators. On the first SCLK falling edge following the busy indicator bit, all devices in the chain output their conversion data starting with the MSB bit. Afterwards, the next lower data bit is output on every SCLK falling edge. While every device outputs its data on the SDO pin, each device also receives the previous device data on the SDI pin (except for device 1) and stores the data in the shift register. Each device latches incoming data on every SCLK falling edge. The SDO of the first device in the chain goes high after the 17th SCLK falling edge. All subsequent devices in the chain output the stored data from the pervious device in MSB-first format immediately following their own data word. $16 \times N + 1$ clock pulses are required to read data for N devices in the chain.

10 Application and Implementation

NOTE

Information in the following applications sections is not part of the TI component specification, and TI does not warrant its accuracy or completeness. TI's customers are responsible for determining suitability of components for their purposes. Customers should validate and test their design implementation to confirm system functionality.

10.1 Application Information

To obtain the best performance from a high-precision successive approximation register (SAR) analog-to-digital converter (ADC), the reference driver and the input driver circuit must be optimized. This section details general principles for designing such drivers, followed by typical application circuits designed using the ADS8339.

10.1.1 ADC Reference Driver

A simplified circuit diagram for such a reference driver is shown in [Figure 58](#). The external voltage reference must provide a low-noise, low-drift, highly-accurate voltage for the ADC reference input pin. The output broadband noise of most voltage references can be in the order of a few hundred μV_{RMS} , which degrades the conversion result. To prevent any noticeable degradation in the noise performance of the ADC, the noise from the voltage reference must be filtered. This filtering can be done by using a low-pass filter with a cutoff frequency of a few hundred hertz.

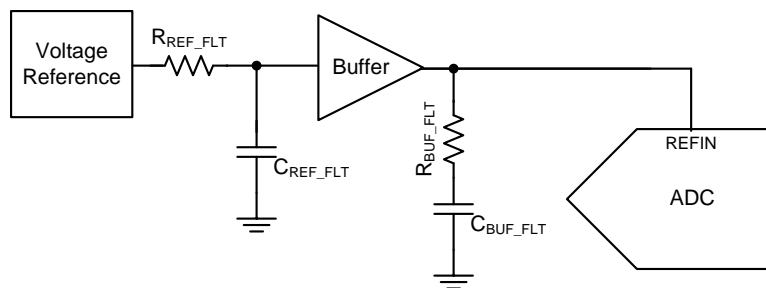

Figure 58. Reference Driver Schematic

During the conversion process, the ADS8339 switches binary-weighted capacitors onto the reference pin (REFIN). The switching frequency is proportional to the internal conversion clock frequency. The dynamic charge required by the capacitors is a function of the ADC input voltage and the reference voltage. Design the reference driver circuit such that the dynamic loading of the capacitors can be handled without degrading the noise and linearity performance of the ADC.

When the noise of the voltage reference is band-limited the next step is to design a reference buffer that can drive the dynamic load posed during the conversion cycle. The buffer must regulate the voltage at the REFIN pin of the device such that the reference voltage to the ADC stays within 1 LSB of an error at the start of each conversion. This condition necessitates the use of a large capacitor, $C_{\text{BUF_FLT}}$ (as shown in [Figure 58](#)). The amplifier selected as the buffer must have very low offset, temperature drift, and output impedance to drive the internal binary-weighted capacitors at the REFIN pin of the ADC without any stability issues.

Application Information (continued)

10.1.1.1 Reference Driver Circuit

A more detailed circuit shows the schematic (as shown in [Figure 59](#)) of a complete reference driver circuit that generates 4.5 V dc using a single 5-V supply. This circuit can drive the reference pin of the ADS8339 at sampling rates of up to 250 kSPS. The 4.5-V reference voltage is generated using a high-precision, low-noise [REF5045](#). The output broadband noise of the reference is further filtered using a low-pass filter with a 3-dB cutoff frequency of 16 Hz.

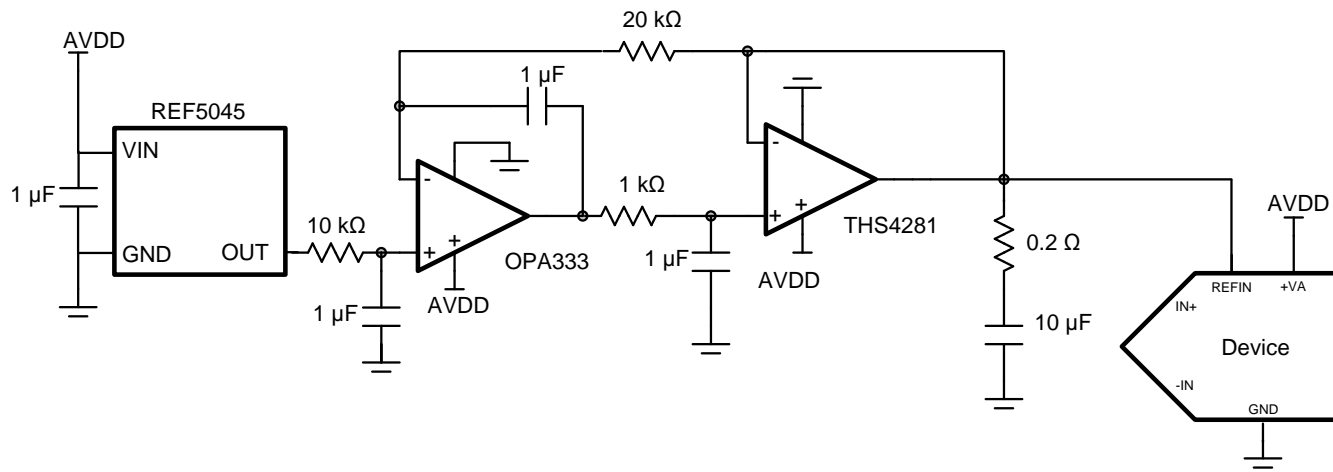

Figure 59. Reference Driver Circuit Schematic

The driver also includes a [THS4281](#) and an [OPA333](#). This composite architecture provides superior ac and dc performance at reduced power levels compared to a single high-performance amplifier.

The THS4281 is a high-bandwidth amplifier with very low output impedance of 1 Ω at a frequency of 1 MHz. The low output impedance makes the THS4281 a good choice for driving large capacitive loads. The high offset and drift specifications of the THS4281 are corrected using a dc-correcting amplifier (OPA333) inside the feedback loop. Thus, the composite scheme also inherits the extremely low offset and temperature drift specifications of the OPA333.

10.1.2 ADC Input Driver

The input driver circuit for a high-precision ADC mainly consists of two parts: a driving amplifier and an RC filter. An amplifier is used for signal conditioning the input voltage. The low output impedance of the amplifier functions as a buffer between the signal source and the sampling capacitor input of the ADC. The RC filter functions as an antialiasing filter that band-limits the wideband noise contributed by the front-end circuit. The RC filter also helps attenuate the sampling capacitor charge injection from the switched-capacitor input stage of the ADC. Careful design of the front-end circuit is critical to meet the linearity and noise performance of a high-precision, 16-bit ADC such as the ADS8339.

Application Information (continued)

10.1.2.1 Input Amplifier Selection

Selection criteria for the input amplifier is dependent on the input signal type as well as performance goals of the data acquisition system. Some key specifications to consider when selecting an amplifier to drive the inputs of the ADS8339 are:

- **Small-signal bandwidth.** The small-signal bandwidth of the input amplifier must be as high as possible for a given power budget. Higher bandwidth reduces the closed-loop output impedance of the amplifier, thus allowing the amplifier to more easily drive the RC filter (with low cutoff frequency) at the inputs of the ADC. Higher bandwidth also minimizes harmonic distortion at higher input frequencies. In order to maintain overall stability, the amplifier bandwidth must satisfy [Equation 1](#):

$$\text{Unity – Gain Bandwidth} \geq 4 \times \left(\frac{1}{2\pi \times (R_{FLT} + R_{FLT}) \times C_{FLT}} \right) \quad (1)$$

- **Noise.** Noise contribution of the front-end amplifiers must be as low as possible to prevent any degradation in the overall SNR performance of the system. As a rule of thumb, to ensure that the noise performance of the data acquisition system is not limited by the front-end circuit, keep the total noise contribution from the front-end circuit below 20% of the input-referred noise of the ADC. Noise from the input driver circuit gets band-limited by the RC filter, as given in [Equation 2](#).

$$N_G \times \sqrt{2} \times \sqrt{\left(\frac{V_{1/f_AMP_PP}}{6.6} \right)^2 + e_{n_RMS}^2 \times \frac{\pi}{2} \times f_{-3dB}} \leq \frac{1}{5} \times \frac{V_{REF}}{\sqrt{2}} \times 10^{-\left(\frac{SNR(dB)}{20} \right)}$$

where:

- V_{1/f_AMP_PP} is the peak-to-peak flicker noise in μV ,
- e_{n_RMS} is the amplifier broadband noise density in nV/\sqrt{Hz} ,
- f_{-3dB} is the 3-dB bandwidth of the RC filter, and
- N_G is the noise gain of the front-end circuit, which is equal to 1 in a buffer configuration. (2)
- **Distortion.** The ADC and the input driver introduce nonlinearity in a data acquisition block. As a rule of thumb, to ensure that the distortion performance of the data acquisition system is not limited by the front-end circuit, the distortion of the input driver must be at least 10 dB lower than the distortion of the ADC, as given in [Equation 3](#).

$$\text{THD}_{AMP} \leq \text{THD}_{ADC} - 10 \text{ (dB)} \quad (3)$$

- **Settling Time.** For dc signals with fast transients that are common in a multiplexed application, the input signal must settle to a 16-bit accuracy level at the device inputs during the acquisition time. This condition is critical in maintaining the overall linearity of the ADC. Typically, the amplifier data sheets specify the output settling performance only up to 0.1% to 0.001%, which may not be sufficient for the desired 16-bit accuracy. Therefore, the settling behavior of the input driver must always be verified by TINA™-SPICE simulations before selecting the amplifier.

10.1.2.2 Antialiasing Filter

Converting analog-to-digital signals requires sampling the input signal at a constant rate. Any frequency content in the input signal that is beyond half the sampling frequency is folded back into the low-frequency spectrum, which is undesirable. This process is called *aliasing*. An analog antialiasing filter must be used to remove the high-frequency component (beyond half the sampling frequency) from the input signal before being sampled by the ADC.

An antialiasing filter is designed as a low-pass, RC filter for which the 3-dB bandwidth is optimized based on specific application requirements. For dc signals with fast transients (including multiplexed input signals), a high-bandwidth filter is designed to allow for accurate settling of the signal at the input of the ADC. For ac signals, keep the filter bandwidth as low as possible to band-limit the noise fed into the ADC, which improves the signal-to-noise ratio (SNR) performance of the system.

Application Information (continued)

The RC filter also helps absorb the sampling charge injection from the switched-capacitor input of the ADC. A filter capacitor, C_{FLT} , is connected across the inputs of the ADC (as shown in Figure 60). This capacitor helps absorb the sampling capacitor charge injection in addition to functioning as a charge bucket to quickly charge the internal sample-and-hold capacitors during the acquisition phase.

When selecting this capacitor, as a rule of thumb, the capacitor value must be at least 10 times the ADC sampling capacitor specified on the data sheet. The input sampling capacitance is approximately 59 pF for the ADS8339. The value of C_{FLT} must be greater than 590 pF. The capacitor must be a COG- or NPO-type because these capacitor types have a high-Q, low-temperature coefficient and stable electrical characteristics under varying voltages, frequency, and time.

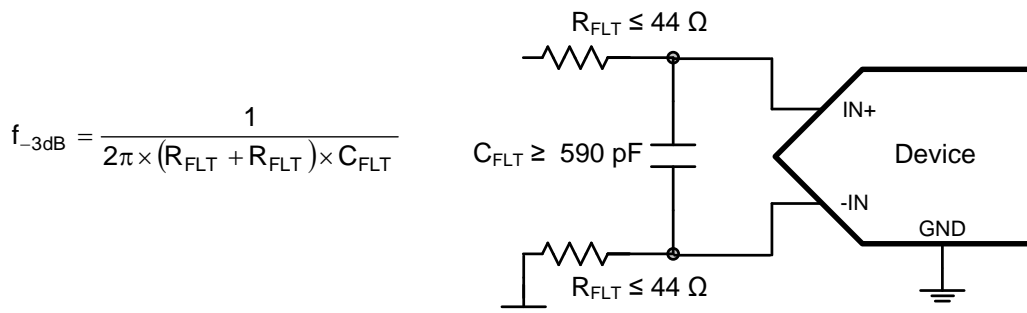

Figure 60. Antialiasing Filter

NOTE

Driving capacitive loads can degrade the phase margin of the input amplifiers, thus making the amplifier marginally unstable. To avoid stability issues, series isolation resistors (R_{FLT}) are used at the output of the amplifiers. A higher value of R_{FLT} is helpful from the amplifier stability perspective. Distortion increases with source impedance, input signal frequency, and input signal amplitude. The selection of R_{FLT} thus requires a balance between stability and distortion of the design.

TI recommends limiting the value of R_{FLT} to a maximum of 44 Ω in order to avoid any significant degradation in linearity performance for the ADS8339. The tolerance of resistors can be 1% because the differential capacitor at the input balances the effects resulting from resistor mismatch.

The input amplifier bandwidth must be much higher than the cutoff frequency of the antialiasing filter. TI strongly recommends running a SPICE simulation to confirm that the amplifier has more than 40° phase margin with the filter that is designed. Simulation is critical because some amplifiers may require more bandwidth than others to drive similar filters. If an amplifier has less than 40° phase margin with 44- Ω resistors, using a different amplifier with higher bandwidth or reducing the filter cutoff frequency with a larger differential capacitor is advisable.

10.2 Typical Application

This section describes a typical application circuit using the ADS8339. The circuit is optimized to derive the best ac performance. For simplicity, power-supply decoupling capacitors are not shown in these circuit diagrams.

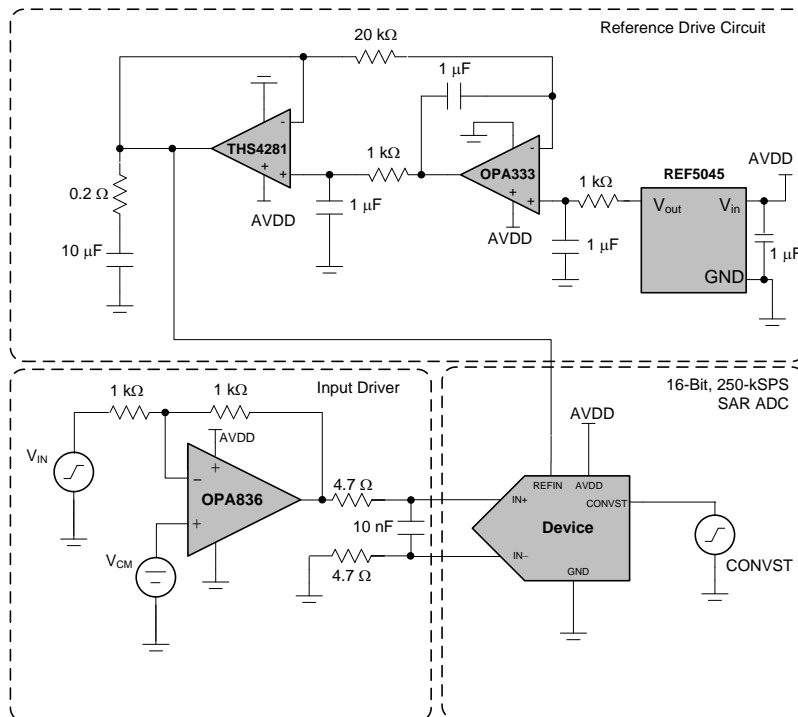

Figure 61. Single-Ended Input DAQ Circuit for Lowest Distortion and Noise at 250 kSPS

10.2.1 Design Requirements

The application circuit for the ADS8339 (as shown in [Figure 61](#)) is optimized for lowest distortion and noise for a 10-kHz input signal to achieve:

- -106 -dB THD and 93-dB SNR at a maximum specified throughput of 250 kSPS.

10.2.2 Detailed Design Procedure

In the application circuit, the input signal is processed through a high-bandwidth, low-distortion, inverting amplifier and a low-pass RC filter before being fed to the ADC.

The reference driver circuit illustrated in [Figure 59](#) generates 4.5 V dc using a single 5-V supply. This circuit is suitable to drive the reference at sampling rates of up to 250 kSPS. To keep the noise low, a high-precision REF5045 is used. The output broadband noise of the reference is heavily filtered by a low-pass filter with a 3-dB cutoff frequency of 16 Hz.

The reference buffer is designed in a composite architecture to achieve superior dc and ac performance at reduced power consumption. The low output impedance makes the THS4281 a good choice for driving large capacitive loads that regulate the voltage at the reference input pin of the ADC. The high offset and drift specifications of the THS4281 are corrected by using a dc-correcting amplifier (such as the OPA333) inside the feedback loop.

For the input driver, as a rule of thumb, the distortion of the amplifier must be at least 10 dB less than the ADC distortion. The distortion resulting from variation in the common-mode signal is eliminated by using the driver in an inverting gain configuration. This configuration also eliminates the need for an amplifier that supports rail-to-rail input. The OPA836 is a good choice for an input driver because of its low-power consumption and exceptional ac performance (such as low distortion and high bandwidth).

Finally, the components of the antialiasing filter are chosen such that the noise from the front-end circuit is kept low without adding distortion to the input signal.

Typical Application (continued)

10.2.3 Application Curve

To ensure that the circuit meets the design requirements, the dc noise performance and the frequency content of the digitized output is verified. The input is set to a fixed dc value at half the reference. The histogram of the output code shows a peak-to-peak noise distribution of four codes which translates to 14 bits of noise-free bits.

An ac signal at 10 kHz is then fed to the input. The FFT of the output shows a THD of –106 dB and an SNR of 92 dB, which is close to the design requirements.

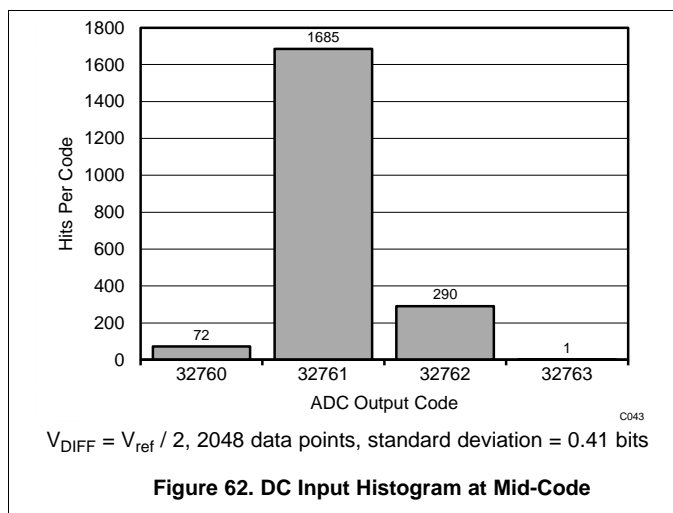

Figure 62. DC Input Histogram at Mid-Code

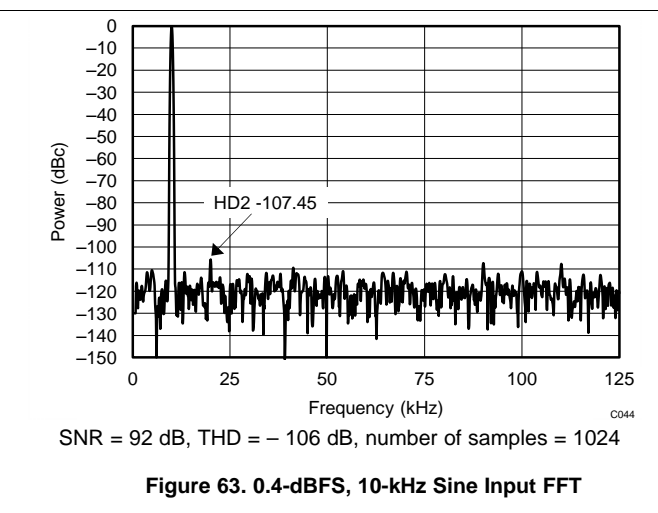

Figure 63. 0.4-dBFS, 10-kHz Sine Input FFT

10.3 Do's and Don'ts

- Use multiple capacitors to decouple the dynamic current transients at various input pins including the reference, supply, and input signal.
- Parasitic inductance can induce ringing on the clock signal. Include a resistor on the SCLK pin to clean up the clock edges.

11 Power-Supply Recommendations

The ADS8339 is designed to operate from an analog supply voltage range between 4.5 V and 5.5 V and a digital supply voltage range between 2.375 V and 5.5 V. Both supplies must be well regulated. The analog supply must always be greater than or equal to the digital supply. A 1- μ F ceramic decoupling capacitor is required at each supply pin and must be placed as close as possible to the device.

12 Layout

12.1 Layout Guidelines

Figure 64 shows one of the board layouts as an example when using ADS8339 in a circuit.

- A printed circuit board (PCB) board with at least four layers is recommended to keep all critical components on the top layer.
- Analog input signals and the reference input signals must be kept away from noise sources. Crossing digital lines with the analog signal path should be avoided. The analog input and the reference signals are routed on to the left side of the board and the digital connections are routed on the right side of the device.
- Due to the dynamic currents that occur during conversion and data transfer, each supply pin (AVDD and DVDD) must have a decoupling capacitor that keeps the supply voltage stable. TI recommends using one 1- μF ceramic capacitor at each supply pin.
- A layout that interconnects the converter and accompanying capacitors with the low inductance path is critical for achieving optimal performance. Using 15-mil vias to interconnect components to a solid analog ground plane at the subsequent inner layer minimizes stray inductance. Avoid placing vias between the supply pin and the decoupling capacitor. Any inductance between the supply capacitor and the supply pin of the converter must be kept to less than 5 nH by placing the capacitor within 0.2 inches from the supply or input pins of the ADS8339 and by using 20-mil traces, as shown in Figure 64.
- Dynamic currents are also present at the REF pin during the conversion phase. Therefore, good decoupling is critical to achieve optimal performance. The inductance between the reference capacitor and the REF pin must be kept to less than 2 nH by placing the capacitor within 0.1 inches from the REF pin and by using 20-mil traces.
- A single 10- μF , X7R-grade, 0805-size ceramic capacitor with at least a 10-V rating is recommended for good performance over temperature range.
- A small, 0.1- Ω to 0.47- Ω , 0603-size resistor placed in series with the reference capacitor keeps the overall impedance low and constant, especially at very high frequencies.
- Avoid using additional lower value capacitors because the interactions between multiple capacitors can affect the ADC performance at higher sampling rates.
- Place the RC filters immediately next to the input pins. Among surface-mount capacitors, COG (NPO) ceramic capacitors provide the best capacitance precision. The type of dielectric used in COG (NPO) ceramic capacitors provides the most stable electrical properties over voltage, frequency, and temperature changes.

12.2 Layout Example

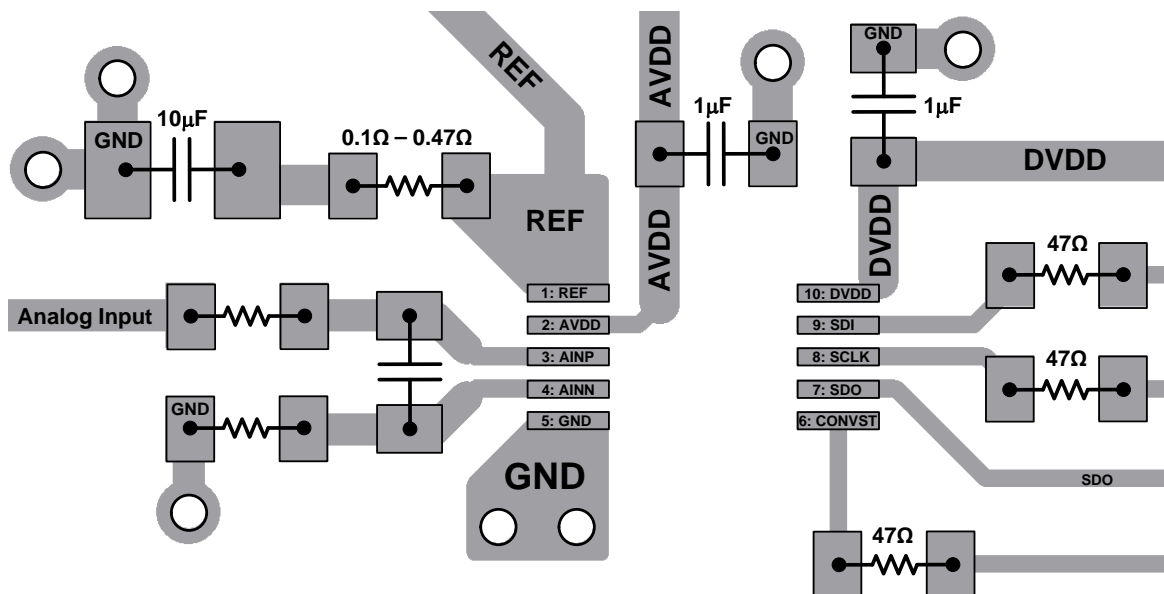

Figure 64. Board Layout Example

13 Device and Documentation Support

13.1 Documentation Support

13.1.1 Related Documentation

REF5045 Data Sheet, [SBOS410](#)

THS4281 Data Sheet, [SLOS432](#)

OPA333 Data Sheet, [SBOS351](#)

OPA836 Data Sheet, [SLOS713](#)

ADS886xEVM-PDK and ADS83x9EVM-PDK User Guide, [SBAU233](#)

13.2 Trademarks

TINA is a trademark of Texas Instruments Inc..

SPI is a trademark of Motorola.

All other trademarks are the property of their respective owners.

13.3 Electrostatic Discharge Caution



This integrated circuit can be damaged by ESD. Texas Instruments recommends that all integrated circuits be handled with appropriate precautions. Failure to observe proper handling and installation procedures can cause damage.

ESD damage can range from subtle performance degradation to complete device failure. Precision integrated circuits may be more susceptible to damage because very small parametric changes could cause the device not to meet its published specifications.

13.4 Glossary

[SLYZ022](#) — *TI Glossary*.

This glossary lists and explains terms, acronyms, and definitions.

14 Mechanical, Packaging, and Orderable Information

The following pages include mechanical, packaging, and orderable information. This information is the most current data available for the designated devices. This data is subject to change without notice and revision of this document. For browser-based versions of this data sheet, refer to the left-hand navigation.

PACKAGING INFORMATION

Orderable Device	Status (1)	Package Type	Package Drawing	Pins	Package Qty	Eco Plan (2)	Lead finish/ Ball material (6)	MSL Peak Temp (3)	Op Temp (°C)	Device Marking (4/5)	Samples
ADS8339IDGSR	ACTIVE	VSSOP	DGS	10	2500	RoHS & Green	SN	Level-2-260C-1 YEAR	-40 to 85	8339	Samples
ADS8339IDGST	ACTIVE	VSSOP	DGS	10	250	RoHS & Green	SN	Level-2-260C-1 YEAR	-40 to 85	8339	Samples

(1) The marketing status values are defined as follows:

ACTIVE: Product device recommended for new designs.

LIFEBUY: TI has announced that the device will be discontinued, and a lifetime-buy period is in effect.

NRND: Not recommended for new designs. Device is in production to support existing customers, but TI does not recommend using this part in a new design.

PREVIEW: Device has been announced but is not in production. Samples may or may not be available.

OBSELETE: TI has discontinued the production of the device.

(2) **RoHS:** TI defines "RoHS" to mean semiconductor products that are compliant with the current EU RoHS requirements for all 10 RoHS substances, including the requirement that RoHS substance do not exceed 0.1% by weight in homogeneous materials. Where designed to be soldered at high temperatures, "RoHS" products are suitable for use in specified lead-free processes. TI may reference these types of products as "Pb-Free".

RoHS Exempt: TI defines "RoHS Exempt" to mean products that contain lead but are compliant with EU RoHS pursuant to a specific EU RoHS exemption.

Green: TI defines "Green" to mean the content of Chlorine (Cl) and Bromine (Br) based flame retardants meet JS709B low halogen requirements of <=1000ppm threshold. Antimony trioxide based flame retardants must also meet the <=1000ppm threshold requirement.

(3) MSL, Peak Temp. - The Moisture Sensitivity Level rating according to the JEDEC industry standard classifications, and peak solder temperature.

(4) There may be additional marking, which relates to the logo, the lot trace code information, or the environmental category on the device.

(5) Multiple Device Markings will be inside parentheses. Only one Device Marking contained in parentheses and separated by a "~" will appear on a device. If a line is indented then it is a continuation of the previous line and the two combined represent the entire Device Marking for that device.

(6) Lead finish/Ball material - Orderable Devices may have multiple material finish options. Finish options are separated by a vertical ruled line. Lead finish/Ball material values may wrap to two lines if the finish value exceeds the maximum column width.

Important Information and Disclaimer:The information provided on this page represents TI's knowledge and belief as of the date that it is provided. TI bases its knowledge and belief on information provided by third parties, and makes no representation or warranty as to the accuracy of such information. Efforts are underway to better integrate information from third parties. TI has taken and continues to take reasonable steps to provide representative and accurate information but may not have conducted destructive testing or chemical analysis on incoming materials and chemicals. TI and TI suppliers consider certain information to be proprietary, and thus CAS numbers and other limited information may not be available for release.

In no event shall TI's liability arising out of such information exceed the total purchase price of the TI part(s) at issue in this document sold by TI to Customer on an annual basis.

TAPE AND REEL INFORMATION



QUADRANT ASSIGNMENTS FOR PIN 1 ORIENTATION IN TAPE



*All dimensions are nominal

Device	Package Type	Package Drawing	Pins	SPQ	Reel Diameter (mm)	Reel Width W1 (mm)	A0 (mm)	B0 (mm)	K0 (mm)	P1 (mm)	W (mm)	Pin1 Quadrant
ADS8339IDGSR	VSSOP	DGS	10	2500	330.0	12.4	5.3	3.4	1.4	8.0	12.0	Q1
ADS8339IDGST	VSSOP	DGS	10	250	180.0	12.4	5.3	3.4	1.4	8.0	12.0	Q1

TAPE AND REEL BOX DIMENSIONS

*All dimensions are nominal

Device	Package Type	Package Drawing	Pins	SPQ	Length (mm)	Width (mm)	Height (mm)
ADS8339IDGSR	VSSOP	DGS	10	2500	367.0	367.0	35.0
ADS8339IDGST	VSSOP	DGS	10	250	210.0	185.0	35.0

DGS0010A



PACKAGE OUTLINE

VSSOP - 1.1 mm max height

SMALL OUTLINE PACKAGE

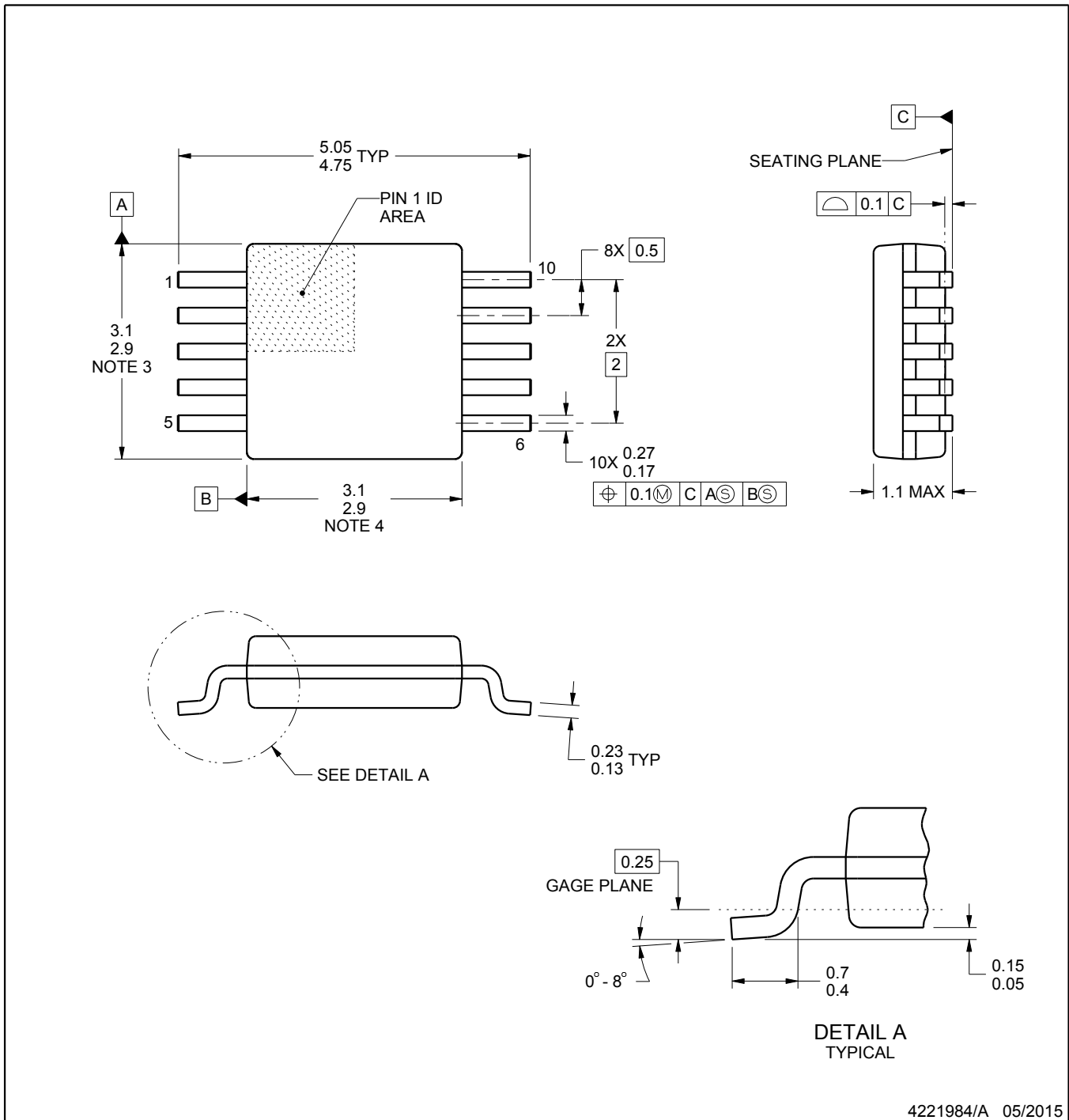

NOTES:

1. All linear dimensions are in millimeters. Any dimensions in parenthesis are for reference only. Dimensioning and tolerancing per ASME Y14.5M.
2. This drawing is subject to change without notice.
3. This dimension does not include mold flash, protrusions, or gate burrs. Mold flash, protrusions, or gate burrs shall not exceed 0.15 mm per side.
4. This dimension does not include interlead flash. Interlead flash shall not exceed 0.25 mm per side.
5. Reference JEDEC registration MO-187, variation BA.

EXAMPLE BOARD LAYOUT

DGS0010A

VSSOP - 1.1 mm max height

SMALL OUTLINE PACKAGE



LAND PATTERN EXAMPLE
SCALE:10X

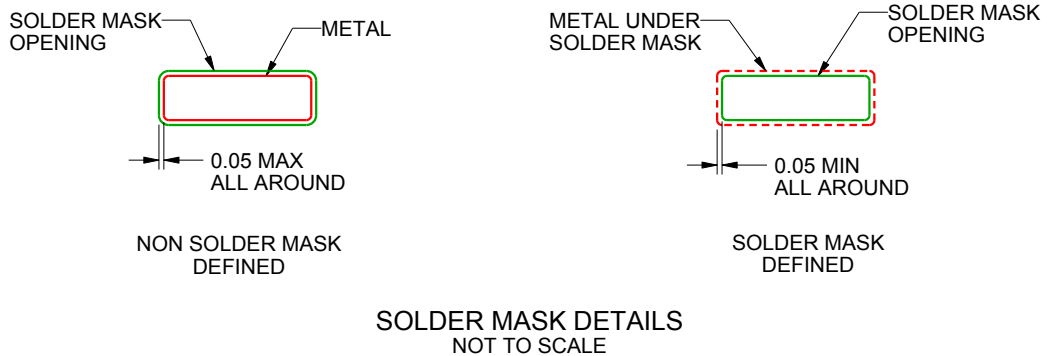

SOLDER MASK DETAILS
NOT TO SCALE

4221984/A 05/2015

NOTES: (continued)

- 6. Publication IPC-7351 may have alternate designs.
- 7. Solder mask tolerances between and around signal pads can vary based on board fabrication site.

EXAMPLE STENCIL DESIGN

DGS0010A

VSSOP - 1.1 mm max height

SMALL OUTLINE PACKAGE



SOLDER PASTE EXAMPLE
BASED ON 0.125 mm THICK STENCIL
SCALE:10X

4221984/A 05/2015

NOTES: (continued)

8. Laser cutting apertures with trapezoidal walls and rounded corners may offer better paste release. IPC-7525 may have alternate design recommendations.
9. Board assembly site may have different recommendations for stencil design.

IMPORTANT NOTICE AND DISCLAIMER

TI PROVIDES TECHNICAL AND RELIABILITY DATA (INCLUDING DATASHEETS), DESIGN RESOURCES (INCLUDING REFERENCE DESIGNS), APPLICATION OR OTHER DESIGN ADVICE, WEB TOOLS, SAFETY INFORMATION, AND OTHER RESOURCES "AS IS" AND WITH ALL FAULTS, AND DISCLAIMS ALL WARRANTIES, EXPRESS AND IMPLIED, INCLUDING WITHOUT LIMITATION ANY IMPLIED WARRANTIES OF MERCHANTABILITY, FITNESS FOR A PARTICULAR PURPOSE OR NON-INFRINGEMENT OF THIRD PARTY INTELLECTUAL PROPERTY RIGHTS.

These resources are intended for skilled developers designing with TI products. You are solely responsible for (1) selecting the appropriate TI products for your application, (2) designing, validating and testing your application, and (3) ensuring your application meets applicable standards, and any other safety, security, or other requirements. These resources are subject to change without notice. TI grants you permission to use these resources only for development of an application that uses the TI products described in the resource. Other reproduction and display of these resources is prohibited. No license is granted to any other TI intellectual property right or to any third party intellectual property right. TI disclaims responsibility for, and you will fully indemnify TI and its representatives against, any claims, damages, costs, losses, and liabilities arising out of your use of these resources.

TI's products are provided subject to TI's Terms of Sale (www.ti.com/legal/termsofsale.html) or other applicable terms available either on ti.com or provided in conjunction with such TI products. TI's provision of these resources does not expand or otherwise alter TI's applicable warranties or warranty disclaimers for TI products.

Mailing Address: Texas Instruments, Post Office Box 655303, Dallas, Texas 75265
Copyright © 2020, Texas Instruments Incorporated

Looking for pricing, stock, or lifecycle information?

Click below to explore more details on WIN SOURCE:

 [View ADS8339IDGSR](#) on WIN SOURCE

 [Texas Instruments](#) Information

Optimize Your Supply Chain with WIN SOURCE Solutions

-  Global Sourcing Solution
-  Obsolete Management
-  Cost Control Management
-  Shortage Management
-  Alternative Solution
-  Excess Inventory Management