



# THE DATASHEET OF NTE5264A





ELECTRONICS, INC.  
 44 FARRAND STREET  
 BLOOMFIELD, NJ 07003  
 (973) 748-5089  
<http://www.nteinc.com>

## NTE5240A thru NTE5296A 50 Watt Zener Diodes ±5% Tolerance

**Features:**

- Zener Voltage 3.9 to 200V
- Low Zener Impedance
- Highly Reliable and Rugged
- Also Available in Reverse Polarity (NTE5240AK thru NTE5296AK)

**Maximum Ratings:**

Operating Junction Temperature Range,  $T_{opr}$  ..... -65° to +175°C  
 Storage Temperature Range,  $T_{stg}$  ..... -65° to +175°C  
 DC Power Dissipation,  $P_D$  ..... 50W  
     Derate Above 75°C ..... 0.5W/°C  
 Forward Voltage ( $I_F = 10A$ ),  $V_F$  ..... 1.5V

Note 1. Suffix “A” denotes anode to case polarity, “AK” denotes cathode to case.

**Electrical Characteristics:** ( $T_C = +30°C$ , unless otherwise specified)

NTE Type Number	Nominal Zener Voltage $V_z @ I_{zt}$ (Note 2)	Zener Test Current ( $I_{zt}$ )	Maximum Dynamic Impedance (Note 3)		Maximum DC Zener Current ( $I_{zm}$ )	Typical Temperature Coefficient $\alpha_{vz}$	Maximum Leakage Current $I_R @ V_R$	
			$Z_{zt} @ I_{zt}$	$Z_{zk} @ 1mA (I_{zk})$			$\mu A$	Volts
			Ohms	Ohms			mA	%/°C
NTE5240A	3.9	3200	0.16	400	11900	-0.046	150	0.5
NTE5241A	4.3	2900	0.16	500	10650	-0.033	150	0.5
NTE5242A	4.7	2650	0.12	600	9700	-0.015	100	1.0
NTE5243A	5.1	2450	0.12	650	8900	±0.010	20	1.0
NTE5244A	5.6	2250	0.12	900	8100	+0.030	29	1.0
NTE5245A	6.0	2125	0.13	950	7700	+0.040	20	1.5
NTE5246A	6.2	2000	0.14	1000	7300	+0.049	20	2.0
NTE5247A	6.8	1850	0.20	70	6600	0.040	300	4.5
NTE5248A	7.5	1700	0.30	70	5900	0.045	125	5.0
NTE5249A	8.2	1500	0.40	70	5200	0.048	50	5.4

**Electrical Characteristics (Cont'd):** ( $T_C = +30^\circ\text{C}$ , unless otherwise specified)

NTE Type Number	Nominal Zener Voltage $V_z @ I_{zt}$ (Note 2)	Zener Test Current ( $I_{zt}$ )	Maximum Dynamic Impedance (Note 3)		Maximum DC Zener Current ( $I_{zm}$ )	Typical Temperature Coefficient $\alpha_{vz}$ %/°C	Maximum Leakage Current $I_R @ V_R$	
			$Z_{zt} @ I_{zt}$	$Z_{zk} @ 1\text{mA } (I_{zk})$			$\mu\text{A}$	Volts
			Ohms	Ohms				
NTE5250A	8.7	1435	0.45	70	5000	0.049	37	5.7
NTE5251A	9.1	1370	0.50	70	4800	0.050	25	6.1
NTE5252A	10.0	1200	0.60	80	4300	0.055	25	6.7
NTE5253A	11.0	1100	0.80	80	3900	0.060	10	8.4
NTE5254A	12.0	1000	1.00	80	3800	0.065	10	9.1
NTE5255A	13.0	960	1.10	80	3300	0.065	10	9.9
NTE5256A	14.0	890	1.20	80	3000	0.070	10	11.4
NTE5257A	15.0	835	1.40	80	2825	0.070	10	11.8
NTE5258A	16.0	780	1.60	80	2650	0.070	10	12.2
NTE5259A	17.0	740	1.80	80	2500	0.075	10	13.0
NTE5260A	18.0	700	2.00	80	2300	0.075	10	13.7
NTE5261A	19.0	660	2.20	80	2200	0.075	10	13.7
NTE5262A	20.0	630	2.40	80	2100	0.075	10	15.2
NTE5263A	22.0	570	2.50	80	1900	0.080	10	16.7
NTE5264A	24.0	520	2.60	80	1750	0.080	10	18.2
NTE5265A	25.0	500	2.70	90	1550	0.080	10	18.2
NTE5266A	27.0	460	2.80	90	1500	0.085	10	20.6
NTE5267A	28.0	440	2.90	90	1450	0.085	10	21.7
NTE5268A	30.0	420	3.00	90	1400	0.085	10	22.8
NTE5269A	33.0	380	3.20	90	1300	0.085	10	25.1
NTE5270A	36.0	350	3.50	90	1150	0.085	10	27.4
NTE5271A	39.0	320	4.00	90	1050	0.090	10	29.7
NTE5272A	43.0	290	4.50	90	975	0.090	10	32.7
NTE5273A	45.0	280	4.50	100	930	0.090	10	32.7
NTE5274A	47.0	270	5.00	100	880	0.090	10	35.8
NTE5275A	50.0	250	5.00	100	830	0.090	10	38.8
NTE5276A	51.0	245	5.20	100	810	0.090	10	38.8
NTE5277A	52.0	240	5.50	100	790	0.090	10	42.6
NTE5278A	56.0	220	6.00	110	740	0.090	10	42.6
NTE5279A	60.0	210	6.50	115	700	0.090	10	44.8
NTE5280A	62.0	200	7.00	120	660	0.090	10	47.1
NTE5281A	68.0	180	8.00	140	600	0.090	10	51.7

**Electrical Characteristics (Cont'd):** ( $T_C = +30^\circ\text{C}$ , unless otherwise specified)

NTE Type Number	Nominal Zener Voltage $V_Z @ I_{ZT}$ (Note 2)	Zener Test Current ( $I_{ZT}$ )	Maximum Dynamic Impedance (Note 3)		Maximum DC Zener Current ( $I_{ZM}$ )	Typical Temperature Coefficient $\alpha_{VZ}$	Maximum Leakage Current $I_R @ V_R$	
			$Z_{ZT} @ I_{ZT}$	$Z_{ZK} @ 1\text{mA} (I_{ZK})$			$\mu\text{A}$	Volts
	Volts	mA	Ohms	Ohms	mA	%/ $^\circ\text{C}$	$\mu\text{A}$	Volts
NTE5282A	75.0	170	9.00	150	540	0.090	10	56.0
NTE5283A	82.0	150	11.00	160	490	0.090	10	62.2
NTE5284A	91.0	140	15.00	180	420	0.090	10	69.2
NTE5285A	100.0	120	20.00	200	400	0.090	10	76.0
NTE5286A	105.0	120	25.00	210	380	0.095	10	83.0
NTE5287A	110.0	110	30.00	220	365	0.095	10	83.0
NTE5288A	120.0	100	40.00	240	335	0.095	10	91.2
NTE5289A	130.0	95	50.00	275	310	0.095	10	99.8
NTE5290A	140.0	90	60.00	325	290	0.095	10	114.0
NTE5291A	150.0	85	75.00	400	270	0.095	10	114.0
NTE5292A	160.0	80	80.00	450	250	0.095	10	121.6
NTE5293A	175.0	70	85.00	500	230	0.095	10	121.6
NTE5294A	180.0	68	90.00	525	220	0.095	10	136.8
NTE5295A	190.0	66	95.00	561	210	0.098	10	144.4
NTE5296A	200.0	65	100.00	600	200	0.100	10	152.0

Note 2. Zener Voltage ( $V_Z$ ) is measured with junction in thermal equilibrium with  $30^\circ\text{C}$  stud temperature.

Note 3. The zener impedance is derived from the 60 cycle A.C. voltage, which results when an AC current having an RMS value equal to 10% of the DC zener current ( $I_{ZT}$  or  $I_{ZK}$ ) is superimposed on  $I_{ZT}$  or  $I_{ZK}$ . Zener impedance is measured at 2 points to insure a sharp knee on the breakdown curve and to eliminate unstable units.

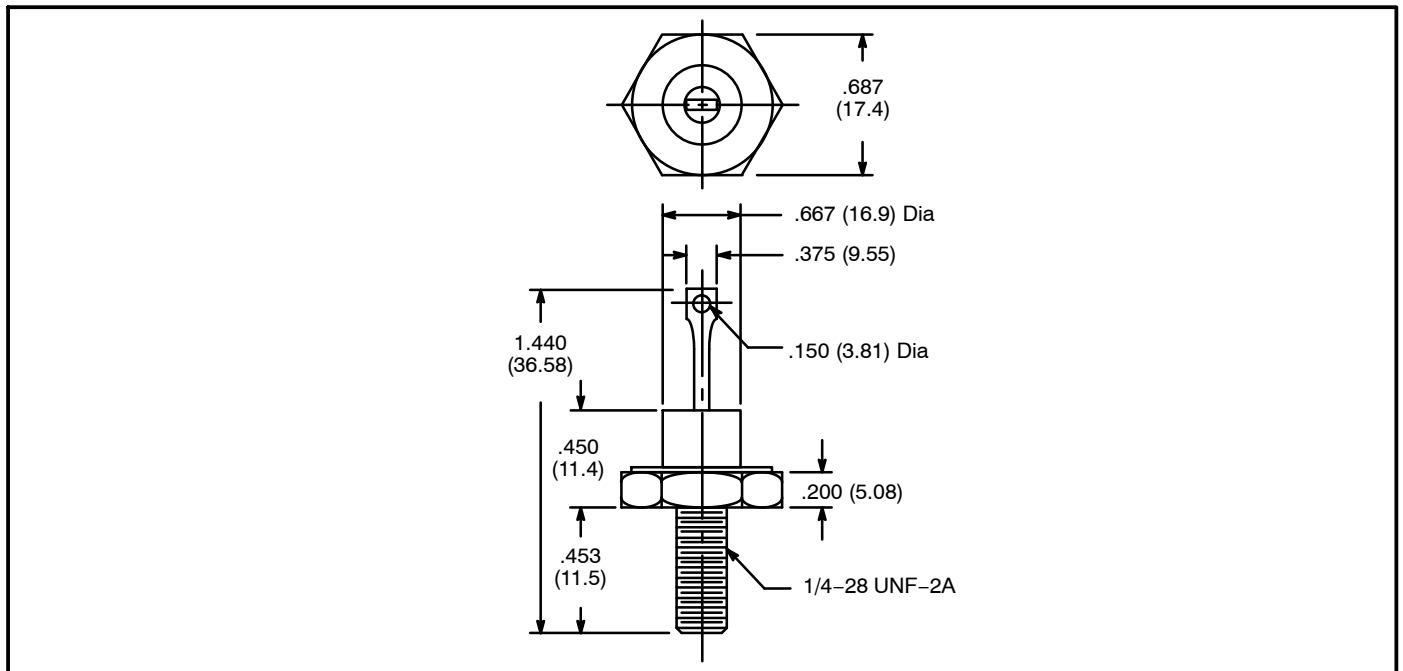

## Looking for pricing, stock, or lifecycle information?

Click below to explore more details on WIN SOURCE:

 [View NTE5264A on WIN SOURCE](#)

 [NTE Information](#)

## Optimize Your Supply Chain with WIN SOURCE Solutions

-  Global Sourcing Solution
-  Obsolete Management
-  Cost Control Management
-  Shortage Management
-  Alternative Solution
-  Excess Inventory Management