



**THE DATASHEET OF
MC10E211FN**



MC10E211, MC100E211

5V ECL 1:6 Differential Clock Distribution Chip

Description

The MC10E/100E211 is a low skew 1:6 fanout device designed explicitly for low skew clock distribution applications.

The E211 features a multiplexed clock input to allow for the distribution of a lower speed scan or test clock along with the high speed system clock. When LOW (or left open in which case it will be pulled LOW by the input pulldown resistor) the SEL pin will select the differential clock input.

Both a common enable and individual output enables are provided. When asserted the positive output will go LOW on the next negative transition of the CLK (or SCLK) input. The enabling function is synchronous so that the outputs will only be enabled/disabled when the outputs are already in the LOW state. In this way the problem of runt pulse generation during the disable operation is avoided. Note that the internal flip flop is clocked on the falling edge of the input clock edge, therefore all associated specifications are referenced to the negative edge of the CLK input.

The output transitions of the E211 are faster than the standard ECLinPS edge rates. This feature provides a means of distributing higher frequency signals than capable with the E111 device. Because of these edge rates and the tight skew limits guaranteed in the specification, there are certain termination guidelines which must be followed. For more details on the recommended termination schemes please refer to the applications information section of this data sheet.

The V_{BB} pin, an internally generated voltage supply, is available to this device only. For single-ended input conditions, the unused differential input is connected to V_{BB} as a switching reference voltage. V_{BB} may also rebias AC coupled inputs. When used, decouple V_{BB} and V_{CC} via a 0.01 μ F capacitor and limit current sourcing or sinking to 0.5 mA. When not used, V_{BB} should be left open.

The 100 Series contains temperature compensation.

Features

- Guaranteed Low Skew Specification
- Synchronous Enabling/Disabling
- Multiplexed Clock Inputs
- V_{BB} Output for Single-Ended Use
- Common and Individual Enable/Disable Control
- High Bandwidth Output Transistors
- PECL Mode Operating Range: $V_{CC} = 4.2$ V to 5.7 V with $V_{EE} = 0$ V
- NECL Mode Operating Range: $V_{CC} = 0$ V with $V_{EE} = -4.2$ V to -5.7 V
- Internal Input 75 k Ω Pulldown Resistors
- ESD Protection: Human Body Model; > 2 kV, Machine Model; > 100 V
- Meets or Exceeds JEDEC Spec EIA/JESD78 IC Latchup Test
- Moisture Sensitivity Level: Pb = 1; Pb-Free = 3 For Additional Information, see Application Note AND8003/D
- Flammability Rating: UL 94 V-0 @ 0.125 in, Oxygen Index: 28 to 34
- Transistor Count = 457 devices
- Pb-Free Packages are Available*

*For additional information on our Pb-Free strategy and soldering details, please download the ON Semiconductor Soldering and Mounting Techniques Reference Manual, SOLDERRM/D.



ON Semiconductor®

<http://onsemi.com>

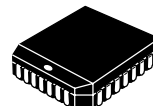

PLCC-28
FN SUFFIX
CASE 776

MARKING DIAGRAM*

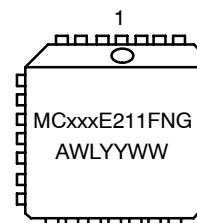

xxx = 10 or 100
A = Assembly Location
WL = Wafer Lot
YY = Year
WW = Work Week
G = Pb-Free Package

*For additional marking information, refer to Application Note AND8002/D.

ORDERING INFORMATION

See detailed ordering and shipping information in the package dimensions section on page 9 of this data sheet.

MC10E211, MC100E211

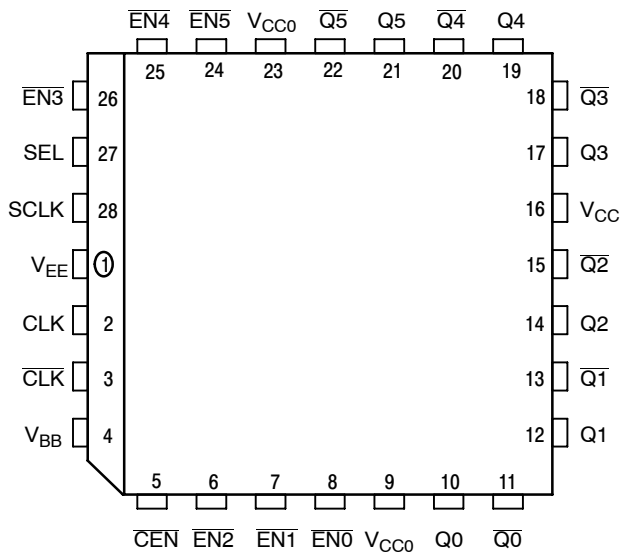

*All V_{CC} and V_{CC0} pins are tied together on the die.

Warning: All V_{CC}, V_{CC0}, and V_{EE} pins must be externally connected to Power Supply to guarantee proper operation.

Figure 1. Pinout: PLCC-28 (Top View)

Table 1. PIN DESCRIPTION

PIN	FUNCTION
EN0-EN5	ECL Enable
SEL	ECL Select (Clock)
SCLK	ECL Single Clock
CLK, CLK	ECL Differential Clock
CEN	ECL Common Enable
Q0-Q5, Q0-Q5	ECL Differential Outputs
V _{BB}	Reference Voltage Output
V _{CC} , V _{CC0}	Positive Supply
V _{EE}	Negative Supply
NC	No Connect

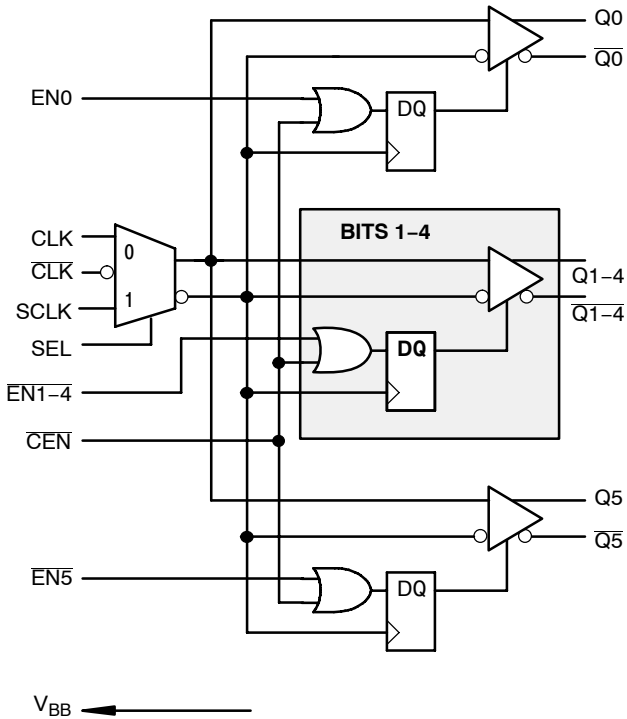

Figure 2. Logic Diagram

Table 2. FUNCTION TABLE

CLK	SCLK	SEL	EN _x	Q
H/L	X	L	L	CLK
X	H/L	H	L	SCLK
Z*	Z*	X	H	L

*Z = Negative transition of CLK or SCLK

MC10E211, MC100E211

Table 3. MAXIMUM RATINGS

Symbol	Parameter	Condition 1	Condition 2	Rating	Unit
V _{CC}	PECL Mode Power Supply	V _{EE} = 0 V		8	V
V _{EE}	NECL Mode Power Supply	V _{CC} = 0 V		-8	V
V _I	PECL Mode Input Voltage	V _{EE} = 0 V	V _I ≤ V _{CC}	6	V
	NECL Mode Input Voltage	V _{CC} = 0 V	V _I ≥ V _{EE}	-6	V
I _{out}	Output Current	Continuous Surge		50	mA
				100	mA
I _{BB}	V _{BB} Sink/Source			± 0.5	mA
T _A	Operating Temperature Range			0 to +85	°C
T _{stg}	Storage Temperature Range			-65 to +150	°C
θ _{JA}	Thermal Resistance (Junction-to-Ambient)	0 lfpm	PLCC-28	63.5	°C/W
		500 lfpm	PLCC-28	43.5	°C/W
θ _{JC}	Thermal Resistance (Junction-to-Case)	Standard Board	PLCC-28	22 to 26	°C/W
V _{EE}	PECL Operating Range			4.2 to 5.7	V
	NECL Operating Range			-5.7 to -4.2	V
T _{sol}	Wave Solder	Pb Pb-Free		265	°C
				265	

Stresses exceeding Maximum Ratings may damage the device. Maximum Ratings are stress ratings only. Functional operation above the Recommended Operating Conditions is not implied. Extended exposure to stresses above the Recommended Operating Conditions may affect device reliability.

MC10E211, MC100E211

Table 4. 10E SERIES PECL DC CHARACTERISTICS $V_{CCx} = 5.0\text{ V}$; $V_{EE} = 0.0\text{ V}$ (Note 1)

Symbol	Characteristic	0°C			25°C			85°C			Unit
		Min	Typ	Max	Min	Typ	Max	Min	Typ	Max	
I_{EE}	Power Supply Current		119	160		119	160		119	160	mA
V_{OH}	Output HIGH Voltage (Note 2)	3980	4070	4160	4020	4105	4190	4090	4185	4280	mV
V_{OL}	Output LOW Voltage (Note 2)	3050	3210	3370	3050	3210	3370	3050	3227	3405	mV
V_{IH}	Input HIGH Voltage (Single-Ended)	3830	3995	4160	3870	4030	4190	3940	4110	4280	mV
V_{IL}	Input LOW Voltage (Single-Ended)	3050	3285	3520	3050	3285	3520	3050	3302	3555	mV
V_{BB}	Output Voltage Reference	3.62		3.74	3.65		3.75	3.69		3.81	V
V_{IHCMR}	Input HIGH Voltage Common Mode Range (Differential Configuration) (Note 3)	2.4		4.6	2.4		4.6	2.4		4.6	V
I_{IH}	Input HIGH Current			150			150			150	μA
I_{IL}	Input LOW Current	0.5	0.3		0.5	0.25		0.3	0.2		μA

NOTE: Device will meet the specifications after thermal equilibrium has been established when mounted in a test socket or printed circuit board with maintained transverse airflow greater than 500 lfpm. Electrical parameters are guaranteed only over the declared operating temperature range. Functional operation of the device exceeding these conditions is not implied. Device specification limit values are applied individually under normal operating conditions and not valid simultaneously.

1. Input and output parameters vary 1:1 with V_{CC} . V_{EE} can vary $-0.46\text{ V} / +0.06\text{ V}$.
2. Outputs are terminated through a $50\ \Omega$ resistor to $V_{CC} - 2.0\text{ V}$.
3. V_{IHCMR} min varies 1:1 with V_{EE} , max varies 1:1 with V_{CC} .

Table 5. 10E SERIES NECL DC CHARACTERISTICS $V_{CCx} = 0.0\text{ V}$; $V_{EE} = -5.0\text{ V}$ (Note 4)

Symbol	Characteristic	0°C			25°C			85°C			Unit
		Min	Typ	Max	Min	Typ	Max	Min	Typ	Max	
I_{EE}	Power Supply Current		119	160		119	160		119	160	mA
V_{OH}	Output HIGH Voltage (Note 5)	-1020	-930	-840	-980	-895	-810	-910	-815	-720	mV
V_{OL}	Output LOW Voltage (Note 5)	-1950	-1790	-1630	-1950	-1790	-1630	-1950	-1773	-1595	mV
V_{IH}	Input HIGH Voltage (Single-Ended)	-1170	-1005	-840	-1130	-970	-810	-1060	-890	-720	mV
V_{IL}	Input LOW Voltage (Single-Ended)	-1950	-1715	-1480	-1950	-1715	-1480	-1950	-1698	-1445	mV
V_{BB}	Output Voltage Reference	-1.38		-1.27	-1.35		-1.25	-1.31		-1.19	V
V_{IHCMR}	Input HIGH Voltage Common Mode Range (Differential Configuration) (Note 6)	-2.6		-0.4	-2.6		-0.4	-2.6		-0.4	V
I_{IH}	Input HIGH Current			150			150			150	μA
I_{IL}	Input LOW Current	0.5	0.3		0.5	0.065		0.3	0.2		μA

NOTE: Device will meet the specifications after thermal equilibrium has been established when mounted in a test socket or printed circuit board with maintained transverse airflow greater than 500 lfpm. Electrical parameters are guaranteed only over the declared operating temperature range. Functional operation of the device exceeding these conditions is not implied. Device specification limit values are applied individually under normal operating conditions and not valid simultaneously.

4. Input and output parameters vary 1:1 with V_{CC} . V_{EE} can vary $-0.46\text{ V} / +0.06\text{ V}$.
5. Outputs are terminated through a $50\ \Omega$ resistor to $V_{CC} - 2.0\text{ V}$.
6. V_{IHCMR} min varies 1:1 with V_{EE} , max varies 1:1 with V_{CC} .

MC10E211, MC100E211

Table 6. 100E SERIES PECL DC CHARACTERISTICS $V_{CCx} = 5.0\text{ V}$; $V_{EE} = 0.0\text{ V}$ (Note 7)

Symbol	Characteristic	0°C			25°C			85°C			Unit
		Min	Typ	Max	Min	Typ	Max	Min	Typ	Max	
I_{EE}	Power Supply Current		119	160		119	160		137	164	mA
V_{OH}	Output HIGH Voltage (Note 8)	3975	4050	4120	3975	4050	4120	3975	4050	4120	mV
V_{OL}	Output LOW Voltage (Note 8)	3190	3295	3380	3190	3255	3380	3190	3260	3380	mV
V_{IH}	Input HIGH Voltage (Single-Ended)	3835	3975	4120	3835	3975	4120	3835	3975	4120	mV
V_{IL}	Input LOW Voltage (Single-Ended)	3190	3355	3525	3190	3355	3525	3190	3355	3525	mV
V_{BB}	Output Voltage Reference	3.62		3.74	3.62		3.74	3.62		3.74	V
V_{IHCMR}	Input HIGH Voltage Common Mode Range (Differential Configuration) (Note 9)	2.4		4.6	2.4		4.6	2.4		4.6	V
I_{IH}	Input HIGH Current			150			150			150	μA
I_{IL}	Input LOW Current	0.5	0.3		0.5	0.25		0.5	0.2		μA

NOTE: Device will meet the specifications after thermal equilibrium has been established when mounted in a test socket or printed circuit board with maintained transverse airflow greater than 500 lfpm. Electrical parameters are guaranteed only over the declared operating temperature range. Functional operation of the device exceeding these conditions is not implied. Device specification limit values are applied individually under normal operating conditions and not valid simultaneously.

7. Input and output parameters vary 1:1 with V_{CC} . V_{EE} can vary $-0.46\text{ V} / +0.8\text{ V}$.
 8. Outputs are terminated through a $50\ \Omega$ resistor to $V_{CC} - 2.0\text{ V}$.
 9. V_{IHCMR} min varies 1:1 with V_{EE} , max varies 1:1 with V_{CC} .

Table 7. 100E SERIES NECL DC CHARACTERISTICS $V_{CCx} = 0.0\text{ V}$; $V_{EE} = -5.0\text{ V}$ (Note 10)

Symbol	Characteristic	0°C			25°C			85°C			Unit
		Min	Typ	Max	Min	Typ	Max	Min	Typ	Max	
I_{EE}	Power Supply Current		119	160		119	160		137	164	mA
V_{OH}	Output HIGH Voltage (Note 11)	-1025	-950	-880	-1025	-950	-880	-1025	-950	-880	mV
V_{OL}	Output LOW Voltage (Note 11)	-1810	-1705	-1620	-1810	-1745	-1620	-1810	-1740	-1620	mV
V_{IH}	Input HIGH Voltage (Single-Ended)	-1165	-1025	-880	-1165	-1025	-880	-1165	-1025	-880	mV
V_{IL}	Input LOW Voltage (Single-Ended)	-1810	-1645	-1475	-1810	-1645	-1475	-1810	-1645	-1475	mV
V_{BB}	Output Voltage Reference	-1.38		-1.26	-1.38		-1.26	-1.38		-1.26	V
V_{IHCMR}	Input HIGH Voltage Common Mode Range (Differential Configuration) (Note 12)	-2.6		-0.4	-2.6		-0.4	-2.6		-0.4	V
I_{IH}	Input HIGH Current			150			150			150	μA
I_{IL}	Input LOW Current	0.5	0.3		0.5	0.25		0.5	0.2		μA

NOTE: Device will meet the specifications after thermal equilibrium has been established when mounted in a test socket or printed circuit board with maintained transverse airflow greater than 500 lfpm. Electrical parameters are guaranteed only over the declared operating temperature range. Functional operation of the device exceeding these conditions is not implied. Device specification limit values are applied individually under normal operating conditions and not valid simultaneously.

10. Input and output parameters vary 1:1 with V_{CC} . V_{EE} can vary $-0.46\text{ V} / +0.8\text{ V}$.
 11. Outputs are terminated through a $50\ \Omega$ resistor to $V_{CC} - 2.0\text{ V}$.
 12. V_{IHCMR} min varies 1:1 with V_{EE} , max varies 1:1 with V_{CC} .

MC10E211, MC100E211

Table 8. AC CHARACTERISTICS $V_{CCx} = 5.0\text{ V}$; $V_{EE} = 0.0\text{ V}$ or $V_{CCx} = 0.0\text{ V}$; $V_{EE} = -5.0\text{ V}$ (Note 13)

Symbol	Characteristic	0°C			25°C			85°C			Unit
		Min	Typ	Max	Min	Typ	Max	Min	Typ	Max	
f_{MAX}	Maximum Toggle Frequency		700			700			700		MHz
t_{PLH} t_{PHL}	Propagation Delay to Output CLK to Q (Diff) CLK to Q (SE) SCLK to Q SEL to Q	795 745 650 745	930 930 900 970	1065 1115 1085 1195	805 755 650 755	940 940 910 980	1075 1125 1095 1205	825 775 650 775	960 960 930 1000	1095 1145 1115 1225	ps
t_{PHL}	Disable Time CLK or SCLK to Q (Note 15)		600	800		600	800		600	800	ps
t_{skew}	Part-to-Part Skew CLK (Diff) to Q CLK (SE), SCLK to Q Within-Device Skew (Note 14)		50	270 370 75		50	270 370 75			270 370 75	ps
t_{JITTER}	Random Clock Jitter (RMS)		< 1			< 1			< 1		ps
t_s	Setup Time $\overline{EN}x$ to CLK \overline{CEN} to CLK (Note 15)	200 200	-100 0		200 200	-100 0		200 200	-100 0		ps
t_h	Hold Time CLK to $\overline{EN}x$, \overline{CEN} (Note 15)	900	600		900	160		900	600		ps
V_{PP}	Minimum Input Swing (CLK) (Note 16)	0.25		1.0	0.25		1.0	0.25		1.0	V
t_r t_f	Rise/Fall Times (20 – 80%)	150		400	150		400	150		400	ps

NOTE: Device will meet the specifications after thermal equilibrium has been established when mounted in a test socket or printed circuit board with maintained transverse airflow greater than 500 lpm. Electrical parameters are guaranteed only over the declared operating temperature range. Functional operation of the device exceeding these conditions is not implied. Device specification limit values are applied individually under normal operating conditions and not valid simultaneously.

13. 10 Series: V_{EE} can vary $-0.46\text{ V} / +0.06\text{ V}$.

100 Series: V_{EE} can vary $-0.46\text{ V} / +0.8\text{ V}$.

14. Within-Device skew is defined for identical transitions on similar paths through a device.

15. Setup, Hold and Disable times are all relative to a falling edge on CLK or SCLK.

16. Minimum input swing for which AC parameters are guaranteed. Full DC ECL output swings will be generated with only 50 mV input swings.

APPLICATIONS INFORMATION

General Description

The MC10E/100E211 is a 1:6 fanout tree designed explicitly for low skew high speed clock distribution. The device was targeted to work in conjunction with the E111 device to provide another level of flexibility in the design and implementation of clock distribution trees. The individual synchronous enable controls and multiplexed clock inputs make the device ideal as the first level distribution unit in a distribution tree. The device provides the ability to distribute a lower speed scan or test clock along with the high speed system clock to ease the design of system diagnostics and self test procedures. The individual enables could be used to allow for the disabling of individual cards on a backplane in fault tolerant designs.

Because of lower fanout and larger skews the E211 will not likely be used as an alternative to the E111 for the bulk of the clock fanout generation. Figure 3 shows a typical application combining the two devices to take advantage of the strengths of each.

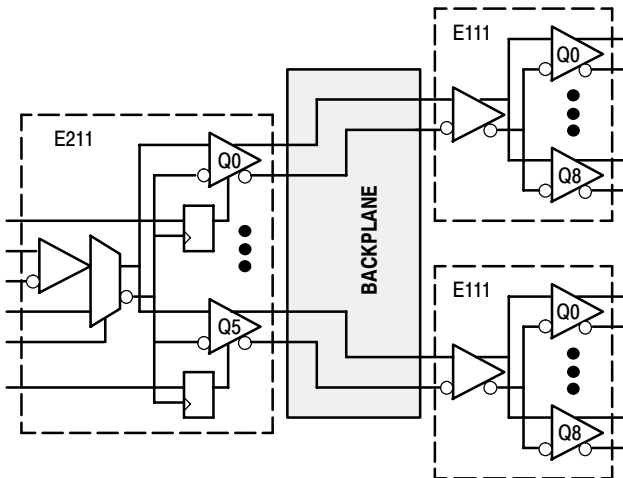

Figure 3. Standard E211 Application

Using the E211 in PECL Designs

The E211 device can be utilized very effectively in designs utilizing only a +5 V power supply. Since the internal switching reference levels are biased off of the V_{CC} supply the input thresholds for the single-ended inputs will vary with V_{CC} . As a result the single-ended inputs should be driven by a device on the same board as the E211. Driving these inputs across a backplane where significant differences between the V_{CC} 's of the transmitter and receiver can occur can lead to AC performance and/or significant noise margin degradations. Because the differential I/O does not use a switching reference, and due to the CMR range of the E211, even under worst case V_{CC}

situations between cards there will be no AC performance or noise margin loss for the differential CLK inputs.

For situations where TTL clocks are required the E211 can be interfaced with the H641 or H643 ECL to TTL Clock Distribution Chips. The H641 is a single supply 1:9 PECL to TTL device while the H643 is a 1:8 dual supply standard ECL to TTL device. By combining the superior skew performance of the E211, or E111, with the low skew translating capabilities of the H641 and H643 very low skew TTL clock distribution networks can be realized.

Handling Open Inputs and Outputs

All of the input pins of the E211 have a 50 k Ω to 75 k Ω pulldown resistor to pull the input to V_{EE} when left open. This feature can cause a problem if the differential clock inputs are left open as the input gate current source transistor will become saturated. Under these conditions the outputs of the CLK input buffer will go to an undefined state. It is recommended, if possible, that the SCLK input should be selected any time the differential CLK inputs are allowed to float. The SCLK buffer, under open input conditions, will maintain a defined output state and thus the Q outputs of the device will be in a defined state ($Q = \text{LOW}$). Note that if all of the inputs are left open the differential CLK input will be selected and the state of the Q outputs will be undefined.

With the simultaneous switching characteristics and the tight skew specifications of the E211 the handling of the unused outputs becomes critical. To minimize the noise generated on the die all outputs should be terminated in pairs, i.e. both the true and complement outputs should be terminated even if only one of the outputs will be used in the system. With both complementary pairs terminated the current in the V_{CC} pins will remain essentially constant and thus inductance induced voltage glitches on V_{CC} will not occur. V_{CC} glitches will result in distorted output waveforms and degradations in the skew performance of the device.

The package parasitics of the PLCC-28 cause the signals on a given pin to be influenced by signals on adjacent pins. The E211 is characterized and tested with all of the outputs switching, therefore the numbers in the data book are guaranteed only for this situation. If all of the outputs of the E211 are not needed and there is a desire to save power the unused output pairs can be left unterminated. Unterminated outputs can influence the propagation delay on adjacent pins by 15 ps – 20 ps. Therefore under these conditions this 15 ps – 20 ps needs to be added to the overall skew of the device. Pins which are separated by a package corner are not considered adjacent pins in the context of propagation delay influence. Therefore as long as all of the outputs on a single side of the package are terminated the specification limits in the data sheet will apply.

APPLICATIONS INFORMATION

Differential versus Single-Ended Use

As can be seen from the data sheet, to minimize the skew of the E211 the device must be used in the differential mode. In the single-ended mode the propagation delays are dependent on the relative position of the V_{BB} switching reference. Any V_{BB} offset from the center of the input swing will add delay to either the T_{PLH} or T_{PHL} and subtract delay from the other. This increase and decrease in delay will lead to an increase in the duty cycle skew and thus part-to-part skew. The within-device skew will be independent of the V_{BB} and therefore will be the same regardless of whether the device is driven differentially or single-ended.

For applications where part-to-part skew or duty cycle skew are not important the advantages of single-ended clock distribution may lead to its use. Using single-ended interconnect will reduce the number of signal traces to be routed, but remember that all of the complementary outputs still need to be terminated therefore there will be no reduction in the termination components required. To use the E211 with a single-ended input the arrangement pictured in Figure 5 should be used. If the input to the differential CLK inputs are AC coupled as pictured in Figure 4 the dependence on a centered V_{BB} reference is removed. The situation pictured will ensure that the input is centered around the bias set by the V_{BB} . As a result when AC coupled the AC specification limits for a differential input can be used. For more information on AC coupling please refer to the interfacing section of the design guide in the ECLinPS data book.

Using the Enable Pins

Both the common enable (\overline{CEN}) and the individual enables (\overline{ENx}) are synchronous to the CLK or SCLK input depending on which is selected. The active low signals are clocked into the enable flip flops on the negative edges of the E211 clock inputs. In this way the devices will only be disabled when the outputs are already in the LOW state. The internal propagation delays are such that the delay to the output through the distribution buffers is less than that through the enable flip flops. This will ensure that the disabling of the device will not slice any time off the clock pulse. On initial power up the enable flip flops will randomly attain a stable state, therefore precautions should be taken on initial power up to ensure the E211 is in the desired state.

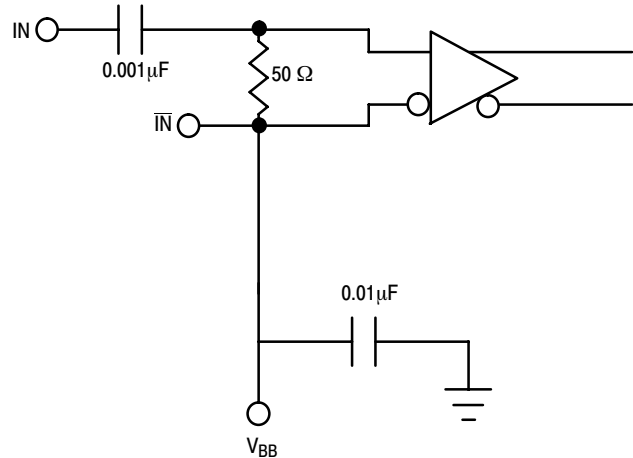

Figure 4. AC Coupled Input

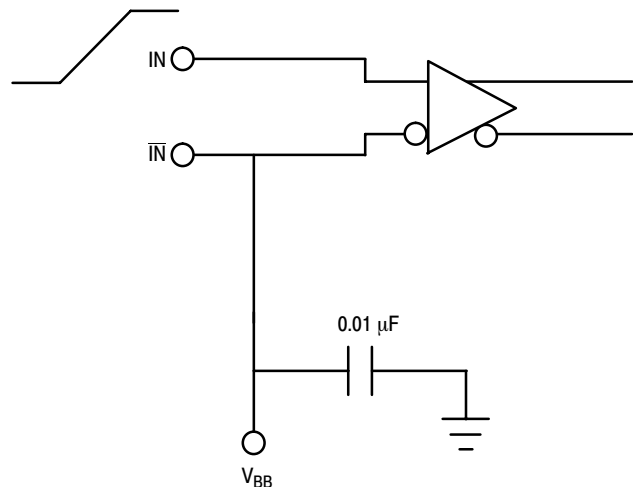

Figure 5. Single-Ended Input

MC10E211, MC100E211

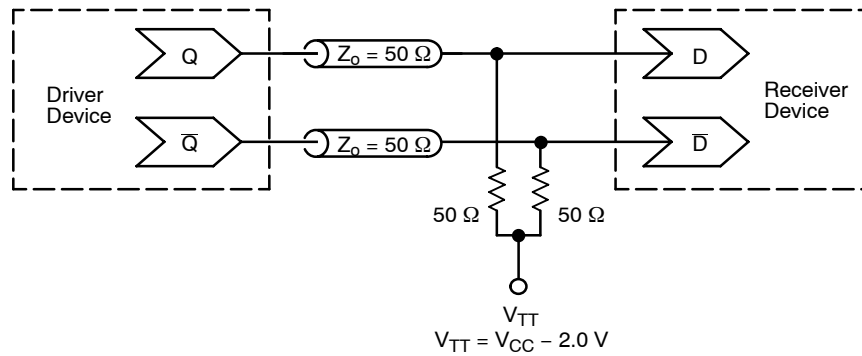

Figure 6. Typical Termination for Output Driver and Device Evaluation
(See Application Note AND8020/D – Termination of ECL Logic Devices.)

ORDERING INFORMATION

Device	Package	Shipping [†]
MC10E211FN	PLCC-28	37 Units / Rail
MC10E211FNG	PLCC-28 (Pb-Free)	37 Units / Rail
MC10E211FNR2	PLCC-28	500 / Tape & Reel
MC10E211FNR2G	PLCC-28 (Pb-Free)	500 / Tape & Reel
MC100E211FN	PLCC-28	37 Units / Rail
MC100E211FNG	PLCC-28 (Pb-Free)	37 Units / Rail
MC100E211FNR2	PLCC-28	500 / Tape & Reel
MC100E211FNR2G	PLCC-28 (Pb-Free)	500 / Tape & Reel

[†]For information on tape and reel specifications, including part orientation and tape sizes, please refer to our Tape and Reel Packaging Specifications Brochure, BRD8011/D.

Resource Reference of Application Notes

- AN1405/D** – ECL Clock Distribution Techniques
- AN1406/D** – Designing with PECL (ECL at +5.0 V)
- AN1503/D** – ECLinPS™ I/O SPICE Modeling Kit
- AN1504/D** – Metastability and the ECLinPS Family
- AN1568/D** – Interfacing Between LVDS and ECL
- AN1672/D** – The ECL Translator Guide
- AND8001/D** – Odd Number Counters Design
- AND8002/D** – Marking and Date Codes
- AND8020/D** – Termination of ECL Logic Devices
- AND8066/D** – Interfacing with ECLinPS
- AND8090/D** – AC Characteristics of ECL Devices

MC10E211, MC100E211

PACKAGE DIMENSIONS

PLCC-28
FN SUFFIX
PLASTIC PLCC PACKAGE
CASE 776-02
ISSUE E

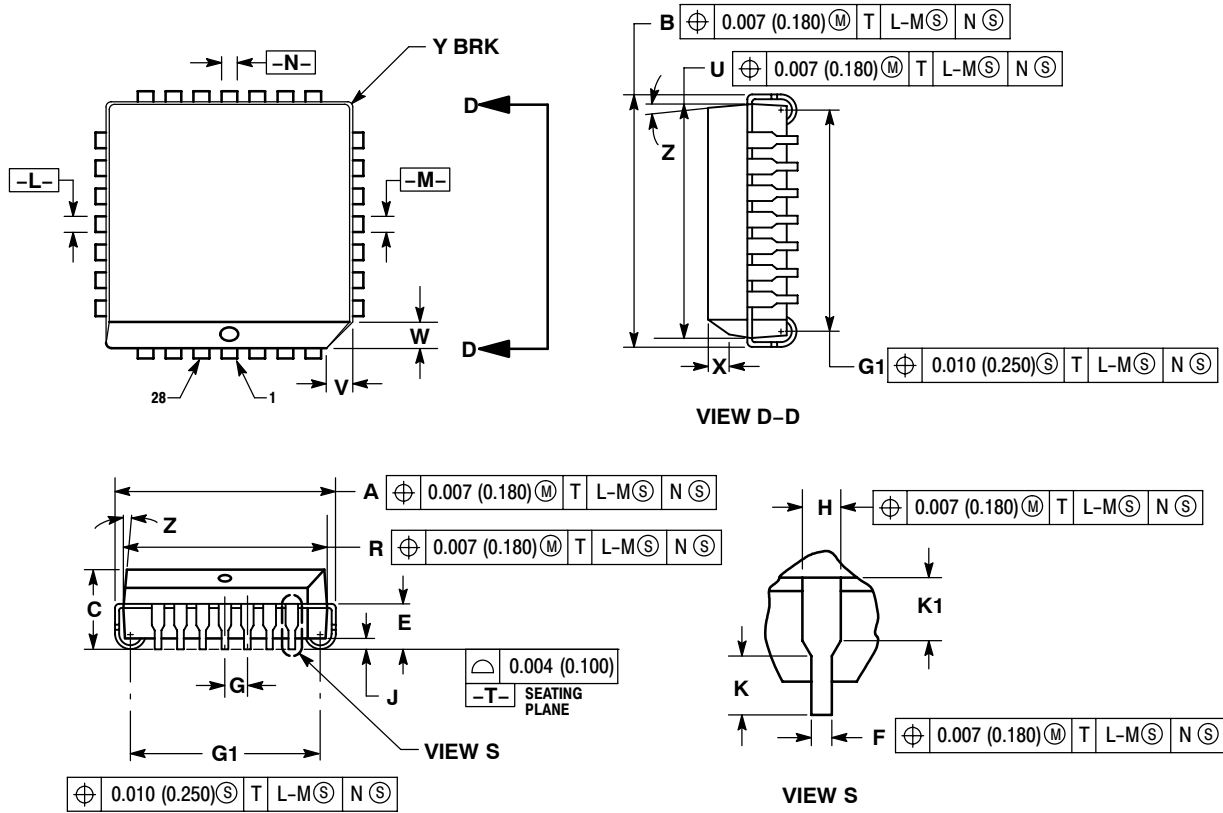

NOTES:

- DATUMS -L-, -M-, AND -N- DETERMINED WHERE TOP OF LEAD SHOULDER EXITS PLASTIC BODY AT MOLD PARTING LINE.
- DIMENSION G1, TRUE POSITION TO BE MEASURED AT DATUM -T-, SEATING PLANE.
- DIMENSIONS R AND U DO NOT INCLUDE MOLD FLASH. ALLOWABLE MOLD FLASH IS 0.010 (0.250) PER SIDE.
- DIMENSIONING AND TOLERANCING PER ANSI Y14.5M, 1982.
- CONTROLLING DIMENSION: INCH.
- THE PACKAGE BOTTOM MAY BE SMALLER THAN THE PACKAGE TOP BY UP TO 0.012 (0.300). DIMENSIONS R AND U ARE DETERMINED AT THE OUTERMOST EXTREMES OF THE PLASTIC BODY EXCLUSIVE OF MOLD FLASH, TIE BAR BURRS, GATE BURRS AND INTERLEAD FLASH, BUT INCLUDING ANY MISMATCH BETWEEN THE TOP AND BOTTOM OF THE PLASTIC BODY.
- DIMENSION H DOES NOT INCLUDE DAMBAR PROTRUSION OR INTRUSION. THE DAMBAR PROTRUSION(S) SHALL NOT CAUSE THE H DIMENSION TO BE GREATER THAN 0.037 (0.940). THE DAMBAR INTRUSION(S) SHALL NOT CAUSE THE H DIMENSION TO BE SMALLER THAN 0.025 (0.635).

DIM	INCHES		MILLIMETERS	
	MIN	MAX	MIN	MAX
A	0.485	0.495	12.32	12.57
B	0.485	0.495	12.32	12.57
C	0.165	0.180	4.20	4.57
E	0.090	0.110	2.29	2.79
F	0.013	0.019	0.33	0.48
G	0.050 BSC		1.27 BSC	
H	0.026	0.032	0.66	0.81
J	0.020	---	0.51	---
K	0.025	---	0.64	---
R	0.450	0.456	11.43	11.58
U	0.450	0.456	11.43	11.58
V	0.042	0.048	1.07	1.21
W	0.042	0.048	1.07	1.21
X	0.042	0.056	1.07	1.42
Y	---	0.020	---	0.50
Z	2° 10°		2° 10°	
G1	0.410	0.430	10.42	10.92
K1	0.040	---	1.02	---

MC10E211, MC100E211

ECLinPS is a trademark of Semiconductor Components Industries, LLC (SCILLC).

ON Semiconductor and **ON** are registered trademarks of Semiconductor Components Industries, LLC (SCILLC). SCILLC reserves the right to make changes without further notice to any products herein. SCILLC makes no warranty, representation or guarantee regarding the suitability of its products for any particular purpose, nor does SCILLC assume any liability arising out of the application or use of any product or circuit, and specifically disclaims any and all liability, including without limitation special, consequential or incidental damages. "Typical" parameters which may be provided in SCILLC data sheets and/or specifications can and do vary in different applications and actual performance may vary over time. All operating parameters, including "Typicals" must be validated for each customer application by customer's technical experts. SCILLC does not convey any license under its patent rights nor the rights of others. SCILLC products are not designed, intended, or authorized for use as components in systems intended for surgical implant into the body, or other applications intended to support or sustain life, or for any other application in which the failure of the SCILLC product could create a situation where personal injury or death may occur. Should Buyer purchase or use SCILLC products for any such unintended or unauthorized application, Buyer shall indemnify and hold SCILLC and its officers, employees, subsidiaries, affiliates, and distributors harmless against all claims, costs, damages, and expenses, and reasonable attorney fees arising out of, directly or indirectly, any claim of personal injury or death associated with such unintended or unauthorized use, even if such claim alleges that SCILLC was negligent regarding the design or manufacture of the part. SCILLC is an Equal Opportunity/Affirmative Action Employer. This literature is subject to all applicable copyright laws and is not for resale in any manner.

PUBLICATION ORDERING INFORMATION

LITERATURE FULFILLMENT:

Literature Distribution Center for ON Semiconductor
P.O. Box 5163, Denver, Colorado 80217 USA
Phone: 303-675-2175 or 800-344-3860 Toll Free USA/Canada
Fax: 303-675-2176 or 800-344-3867 Toll Free USA/Canada
Email: orderlit@onsemi.com

N. American Technical Support: 800-282-9855 Toll Free
USA/Canada
Europe, Middle East and Africa Technical Support:
Phone: 421 33 790 2910
Japan Customer Focus Center
Phone: 81-3-5773-3850

ON Semiconductor Website: www.onsemi.com
Order Literature: <http://www.onsemi.com/orderlit>

For additional information, please contact your local Sales Representative

Looking for pricing, stock, or lifecycle information?

Click below to explore more details on WIN SOURCE:

 [View MC10E211FN](#) on WIN SOURCE

 [ON Semiconductor](#) Information

Optimize Your Supply Chain with WIN SOURCE Solutions

-  Global Sourcing Solution
-  Obsolete Management
-  Cost Control Management
-  Shortage Management
-  Alternative Solution
-  Excess Inventory Management