



**THE DATASHEET OF
SN74GTLP817PWR**



FEATURES

- **OEC™ Circuitry Improves Signal Integrity and Reduces Electromagnetic Interference**
- **Bidirectional Interface Between GTLP Signal Levels and LVTTL Logic Levels**
- **GTL8-to-LVTTL 1-to-6 Fanout Driver**
- **LVTTL-to-GTL8 1-to-2 Fanout Driver**
- **LVTTL Interfaces Are 5-V Tolerant**
- **Medium-Drive GTLP Outputs (50 mA)**
- **Reduced-Drive LVTTL Outputs (–12 mA/12 mA)**
- **Variable Edge-Rate Control (ERC) Input Selects GTLP Rise and Fall Times for Optimal Data-Transfer Rate and Signal Integrity in Distributed Loads**
- **I_{off} and Power-Up 3-State Support Hot Insertion**
- **Distributed V_{CC} and GND Pins Minimize High-Speed Switching Noise**
- **Latch-Up Performance Exceeds 100 mA Per JESD 78, Class II**
- **ESD Protection Exceeds JESD 22**
 - 2000-V Human-Body Model (A114-A)
 - 200-V Machine Model (A115-A)
 - 1000-V Charged-Device Model (C101)

DTV, DV, OR PV PACKAGE
(TOP VIEW)

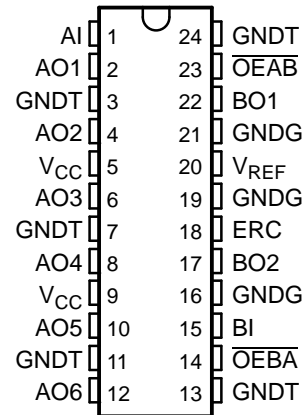

DESCRIPTION/ORDERING INFORMATION

The SN74GTL817 is a medium-drive fanout driver that provides LVTTL-to-GTL8 and GTLP-to-LVTTL signal-level translation. The device provides a high-speed interface between cards operating at LVTTL logic levels and a backplane operating at GTLP signal levels. High-speed (about three times faster than standard TTL or LVTTL) backplane operation is a direct result of GTLP reduced output swing (<1 V), reduced input threshold levels, improved differential input, and OEC™ circuitry. The improved GTLP OEC circuitry minimizes bus settling time and has been designed and tested using several backplane models. The medium drive allows incident-wave switching in heavily loaded backplanes with equivalent load impedance down to 19 Ω. BO1 and BO2 can be tied together to drive an equivalent load impedance down to 11 Ω.

GTL8 is the Texas Instruments (TI™) derivative of the Gunning Transceiver Logic (GTL) JEDEC standard JESD 8-3. The ac specification of the SN74GTL817 is given only at the preferred higher noise-margin GTLP, but the user has the flexibility of using this device at either GTL (V_{TT} = 1.2 V and V_{REF} = 0.8 V) or GTLP (V_{TT} = 1.5 V and V_{REF} = 1 V) signal levels.

Normally, the B port operates at GTLP signal levels. The A-port and control inputs operate at LVTTL logic levels, but are 5-V tolerant and are compatible with TTL and 5-V CMOS inputs. V_{REF} is the B-port differential input reference voltage.

GNDT is the TTL output ground, while GNDG is the GTLP output ground, and both may be separated from each other for a quieter device.



Please be aware that an important notice concerning availability, standard warranty, and use in critical applications of Texas Instruments semiconductor products and disclaimers thereto appears at the end of this data sheet.

OEC, TI are trademarks of Texas Instruments.

SN74GTLP817

GTLP-TO-LVTTL 1-TO-6 FANOUT DRIVER

SCES285E–OCTOBER 1999–REVISED APRIL 2005

DESCRIPTION/ORDERING INFORMATION (CONTINUED)

This device is fully specified for hot-insertion applications using I_{off} and power-up 3-state. The I_{off} circuitry disables the outputs, preventing damaging current backflow through the device when it is powered down. The power-up 3-state circuitry places the outputs in the high-impedance state during power up and power down, which prevents driver conflict.

This device features adjustable edge-rate control (ERC). Changing the ERC input voltage between GND and V_{CC} adjusts the B-port output rise and fall times. This allows the designer to optimize system data-transfer rate and signal integrity to the backplane load. ERC automatically is selected to the same speed as alternate source 1-to-6 fanout drivers that use pin 18 for 3.3-V or 5-V V_{CC} .

When V_{CC} is between 0 and 1.5 V, the device is in the high-impedance state during power up or power down. However, to ensure the high-impedance state above 1.5 V, the output-enable (\overline{OE}) input should be tied to V_{CC} through a pullup resistor; the minimum value of the resistor is determined by the current-sinking capability of the driver.

ORDERING INFORMATION

T_A	PACKAGE ⁽¹⁾		ORDERABLE PART NUMBER	TOP-SIDE MARKING
–40°C to 85°C	SOIC – DW	Tube	SN74GTLP817DW	GTLP817
		Tape and reel	SN74GTLP817DWR	
	TSSOP – PW	Tape and reel	SN74GTLP817PWR	GT817
	TVSOP – DGV	Tape and reel	SN74GTLP817DGVR	GT817

(1) Package drawings, standard packing quantities, thermal data, symbolization, and PCB design guidelines are available at www.ti.com/sc/package.

FUNCTIONAL DESCRIPTION

The SN74GTLP817 is a fanout driver providing LVTTL-to-GTLP translation and GTLP-to-LVTTL translation in the same package.

The LVTTL-to-GTLP direction is a 1-to-2 fanout driver with a single output enable (\overline{OEAB}).

The GTLP-to-LVTTL direction is a 1-to-6 fanout driver with a single output enable ($\overline{OEB A}$).

Data polarity is inverting for both directions.

FUNCTION TABLES

OUTPUT CONTROL
(A TO B)

INPUTS		OUTPUT BOn	MODE
AI	\overline{OEAB}		
X	H	Z	Isolation
H	L	L	Inverted transparent
L	L	H	

OUTPUT CONTROL
(B TO A)

INPUTS		OUTPUT AOn	MODE
BI	\overline{OEBA}		
X	H	Z	Isolation
H	L	L	Inverted transparent
L	L	H	

B-PORT EDGE-RATE CONTROL (ERC)

INPUT ERC		OUTPUT B-PORT EDGE RATE
LOGIC LEVEL	NOMINAL VOLTAGE	
H	V _{CC}	Slow
L	GND	Fast

LOGIC DIAGRAM (POSITIVE LOGIC)

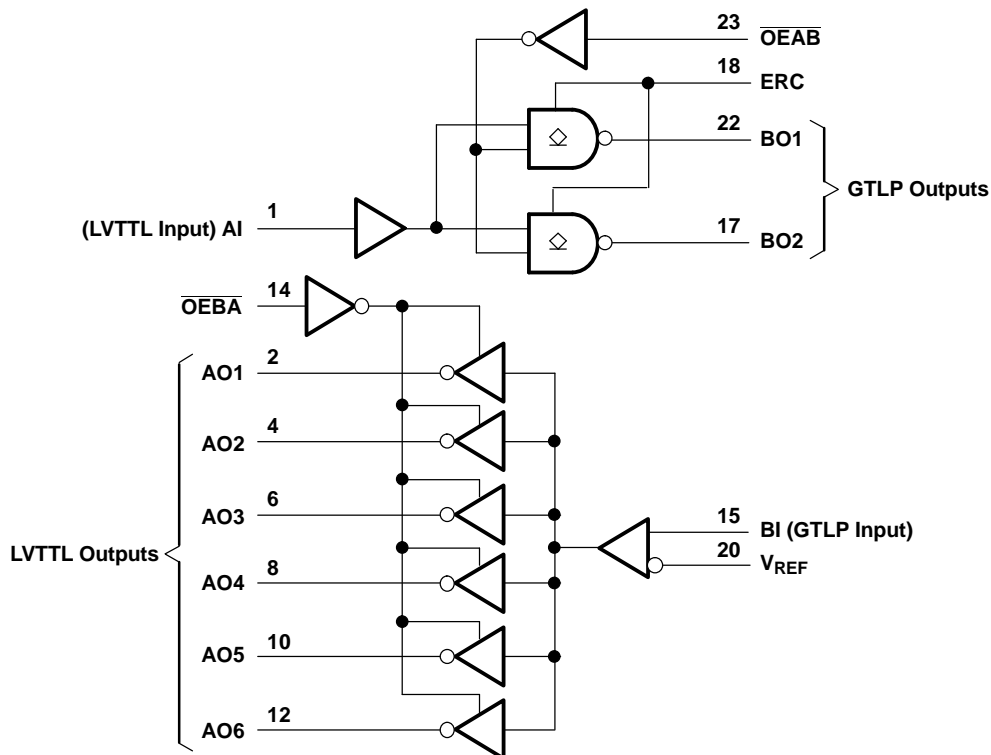

SN74GTLP817

GTLP-TO-LVTTL 1-TO-6 FANOUT DRIVER

SCES285E—OCTOBER 1999—REVISED APRIL 2005



Absolute Maximum Ratings⁽¹⁾

over operating free-air temperature range (unless otherwise noted)

			MIN	MAX	UNIT
V_{CC}	Supply voltage range		-0.5	4.6	V
$ V_{GNDG} - V_{GNDT} $	Ground dc voltage difference			0.3	V
V_I	Input voltage range ⁽²⁾	AI port and control inputs	-0.5	7	V
		BI port and V_{REF}	-0.5	4.6	
V_O	Voltage range applied to any output in the high-impedance or power-off state ⁽²⁾	AO port	-0.5	7	V
		BO port	-0.5	4.6	
I_O	Current into any output in the low state	AO port		24	mA
		BO port		100	
I_O	Current into any A output in the high state ⁽³⁾			24	mA
	Continuous current through each V_{CC} or GND			±100	mA
I_{IK}	Input clamp current	$V_I < 0$		-50	mA
I_{OK}	Output clamp current	$V_O < 0$		-50	mA
θ_{JA}	Package thermal impedance ⁽⁴⁾	DGV package		86	°C/W
		DW package		46	
		PW package		88	
T_{stg}	Storage temperature range		-65	150	°C

(1) Stresses beyond those listed under "absolute maximum ratings" may cause permanent damage to the device. These are stress ratings only, and functional operation of the device at these or any other conditions beyond those indicated under "recommended operating conditions" is not implied. Exposure to absolute-maximum-rated conditions for extended periods may affect device reliability.

(2) The input and output negative-voltage ratings may be exceeded if the input and output clamp-current ratings are observed.

(3) This current flows only when the output is in the high state and $V_O > V_{CC}$.

(4) The package thermal impedance is calculated in accordance with JESD 51-7.

Recommended Operating Conditions⁽¹⁾⁽²⁾⁽³⁾⁽⁴⁾

			MIN	NOM	MAX	UNIT
V_{CC}	Supply voltage		3.15	3.3	3.45	V
V_{TT}	Termination voltage	GTL	1.14	1.2	1.26	V
		GTLP	1.35	1.5	1.65	
V_{REF}	Reference voltage	GTL	0.74	0.8	0.87	V
		GTLP	0.87	1	1.1	
V_I	Input voltage	BI			V_{TT}	V
		AI, \overline{OE}		V_{CC}	5.5	
V_{IH}	High-level input voltage	BI	$V_{REF} + 0.05$			V
		ERC	$V_{CC} - 0.6$	V_{CC}	5.5	
		AI, \overline{OE}	2			
V_{IL}	Low-level input voltage	BI			$V_{REF} - 0.05$	V
		ERC		GND	0.6	
		AI, \overline{OE}			0.8	
I_{IK}	Input clamp current				-18	mA
I_{OH}	High-level output current	AO port			-12	mA
I_{OL}	Low-level output current	AO port			12	mA
		BO port			50	
$\Delta t/\Delta v$	Input transition rise or fall rate	Outputs enabled			10	ns/V
$\Delta t/\Delta V_{CC}$	Power-up ramp rate		20			μ s/V
T_A	Operating free-air temperature		-40		85	$^{\circ}$ C

- (1) All unused inputs of the device must be held at V_{CC} or GND to ensure proper device operation. Refer to the TI application report, *Implications of Slow or Floating CMOS Inputs*, literature number SCBA004.
- (2) Normal connection sequence is GND first and $V_{CC} = 3.3$ V, I/O, control inputs, V_{TT} , V_{REF} (any order) last.
- (3) V_{TT} and R_{TT} can be adjusted to accommodate backplane impedances if the dc recommended I_{OL} ratings are not exceeded.
- (4) V_{REF} can be adjusted to optimize noise margins, but normally is two-thirds V_{TT} .

Electrical Characteristics

over recommended operating free-air temperature range for GTLP (unless otherwise noted)

PARAMETER		TEST CONDITIONS		MIN	TYP ⁽¹⁾	MAX	UNIT	
V_{IK}		$V_{CC} = 3.15\text{ V}$,	$I_I = -18\text{ mA}$			-1.2	V	
V_{OH}	AO port	$V_{CC} = 3.15\text{ V to } 3.45\text{ V}$,	$I_{OH} = -100\text{ }\mu\text{A}$			$V_{CC} - 0.2$	V	
		$V_{CC} = 3.15\text{ V}$	$I_{OH} = -100\text{ }\mu\text{A}$			$V_{CC} - 0.2$		
			$I_{OH} = -6\text{ mA}$			2.4		
			$I_{OH} = -12\text{ mA}$			2.2		
V_{OL}	AO port	$V_{CC} = 3.15\text{ V to } 3.45\text{ V}$,	$I_{OL} = 100\text{ }\mu\text{A}$			0.2	V	
		$V_{CC} = 3.15\text{ V}$	$I_{OL} = 100\text{ }\mu\text{A}$			0.2		
			$I_{OL} = 6\text{ mA}$			0.4		
			$I_{OL} = 12\text{ mA}$			0.5		
	BO port	$V_{CC} = 3.15\text{ V}$	$I_{OL} = 100\text{ }\mu\text{A}$			0.2		
			$I_{OL} = 40\text{ mA}$			0.5		
$I_{OL} = 50\text{ mA}$					0.55			
I_I	BI, AI, \overline{OE} , ERC	$V_{CC} = 3.45\text{ V}$,	$V_I = 0\text{ or } 5.5\text{ V}$			± 5	μA	
I_{OZH}	AO port	$V_{CC} = 3.45\text{ V}$	$V_O = V_{CC}$			10	μA	
	BO port		$V_O = 1.5\text{ V}$			5		
I_{OZL}	AO port	$V_{CC} = 3.45\text{ V}$	$V_O = \text{GND}$			-10	μA	
	BO port		$V_O = 5.5\text{ V}$			-5		
I_{CC}	AO or BO port	$V_{CC} = 3.45\text{ V}$, $I_O = 0$, V_I (AI or control input) = V_{CC} or GND, V_I (BI input) = V_{TT} or GND	Outputs high			10	mA	
			Outputs low			10		
			Outputs disabled			10		
$\Delta I_{CC}^{(2)}$	AI, \overline{OE}	$V_{CC} = 3.45\text{ V}$. One A-port or control input at $V_{CC} - 0.6\text{ V}$, Other A-port or control inputs at V_{CC} or GND				1	mA	
C_i	AI, \overline{OE} , ERC	$V_I = V_{CC}$ or 0				4	4.4	pF
	BI	$V_I = V_{TT}$ or 0				3.5	3.9	
C_o	AO port	$V_O = V_{CC}$ or 0				4	4.5	pF
	BO port	$V_O = V_{TT}$ or 0				5	5.4	

(1) All typical values are at $V_{CC} = 3.3\text{ V}$, $T_A = 25^\circ\text{C}$.

(2) This is the increase in supply current for each input that is at the specified LVTTL voltage level, rather than V_{CC} or GND.

Hot-Insertion Specifications for A Port

over recommended operating free-air temperature range

PARAMETER	TEST CONDITIONS			MIN	MAX	UNIT
I_{off}	$V_{CC} = 0$,	V_I or $V_O = 0\text{ to } 5.5\text{ V}$			10	μA
I_{OZPU}	$V_{CC} = 0\text{ to } 1.5\text{ V}$,	$V_O = 0.5\text{ V to } 3\text{ V}$,	$\overline{OE} = 0$		± 30	μA
I_{OZPD}	$V_{CC} = 1.5\text{ V to } 0$,	$V_O = 0.5\text{ V to } 3\text{ V}$,	$\overline{OE} = 0$		± 30	μA

Hot-Insertion Specifications for B Port

over recommended operating free-air temperature range

PARAMETER	TEST CONDITIONS			MIN	MAX	UNIT
I_{off}	$V_{CC} = 0$,	V_I or $V_O = 0\text{ to } 1.5\text{ V}$			10	μA
I_{OZPU}	$V_{CC} = 0\text{ to } 1.5\text{ V}$,	$V_O = 0.5\text{ V to } 1.5\text{ V}$,	$\overline{OE} = 0$		± 30	μA
I_{OZPD}	$V_{CC} = 1.5\text{ V to } 0$,	$V_O = 0.5\text{ V to } 1.5\text{ V}$,	$\overline{OE} = 0$		± 30	μA

Switching Characteristics

over recommended ranges of supply voltage and operating free-air temperature,
 $V_{TT} = 1.5 \text{ V}$ and $V_{REF} = 1 \text{ V}$ for GTLP (see Figure 1)

PARAMETER	FROM (INPUT)	TO (OUTPUT)	EDGE RATE ⁽¹⁾	MIN	TYP ⁽²⁾	MAX	UNIT
t_{PLH}	AI	BO	Slow	3		6	ns
t_{PHL}				1.8	4.7		
t_{PLH}	AI	BO	Fast	2		5	ns
t_{PHL}				1.5	4.2		
t_{en}	\overline{OEAB}	BO	Slow	3		6.1	ns
t_{dis}				2	4.7		
t_{en}	\overline{OEAB}	BO	Fast	2.1		6	ns
t_{dis}				1.5	4.7		
t_r	Rise time, B outputs (20% to 80%)		Slow	2.5		ns	
			Fast	1.4			
t_f	Fall time, B outputs (80% to 20%)		Slow	1.7		ns	
			Fast	1			
t_{PLH}	BI	AO		2.3		6	ns
t_{PHL}				1.9	4.7		
t_{en}	\overline{OEBA}	AO		1.1		6.3	ns
t_{dis}				1.2	5		

(1) Slow (ERC = V_{CC}) and Fast (ERC = GND)

(2) All typical values are at $V_{CC} = 3.3 \text{ V}$, $T_A = 25^\circ\text{C}$.

PARAMETER MEASUREMENT INFORMATION

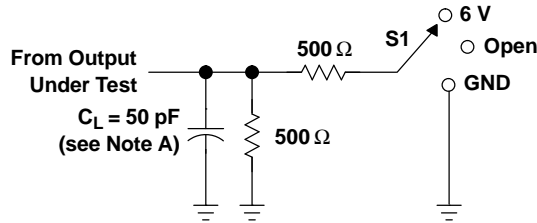

LOAD CIRCUIT FOR AO PORTS

TEST	S1
t_{PLH}/t_{PHL}	Open
t_{PLZ}/t_{PZL}	6 V
t_{PHZ}/t_{PZH}	GND

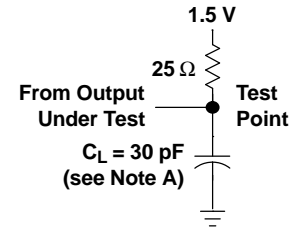

LOAD CIRCUIT FOR BO PORTS

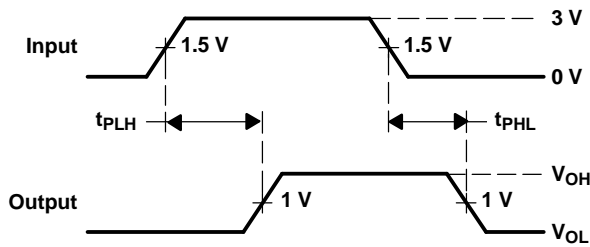

VOLTAGE WAVEFORMS
PROPAGATION DELAY TIMES
(AI to BO port)

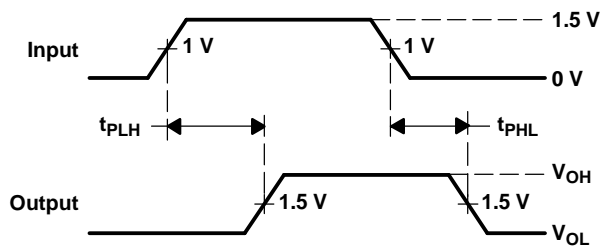

VOLTAGE WAVEFORMS
PROPAGATION DELAY TIMES
(BI to AO port)

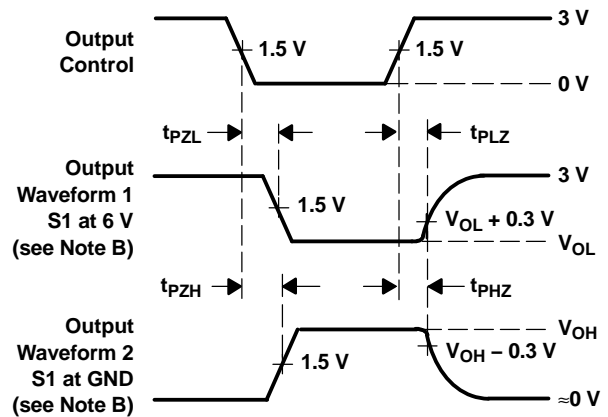

VOLTAGE WAVEFORMS
ENABLE AND DISABLE TIMES
(AO ports)

- NOTES: A. C_L includes probe and jig capacitance.
 B. Waveform 1 is for an output with internal conditions such that the output is low, except when disabled by the output control. Waveform 2 is for an output with internal conditions such that the output is high, except when disabled by the output control.
 C. All input pulses are supplied by generators having the following characteristics: PRR \approx 10 MHz, $Z_O = 50 \Omega$, $t_r \approx 2$ ns, $t_f \approx 2$ ns.
 D. The outputs are measured one at a time, with one transition per measurement.

Figure 1. Load Circuits and Voltage Waveforms

Distributed-Load Backplane Switching Characteristics

The preceding switching characteristics table shows the switching characteristics of the device into a lumped load (Figure 1). However, the designer's backplane application probably is a distributed load. The physical representation is shown in Figure 2. This backplane, or distributed load, can be approximated closely to a resistor inductance capacitance (RLC) circuit, as shown in Figure 3. This device has been designed for optimum performance in this RLC circuit. The following switching characteristics table shows the switching characteristics of the device into the RLC load, to help the designer better understand the performance of the GTLP device in this typical backplane. See www.ti.com/sc/gtlp for more information.

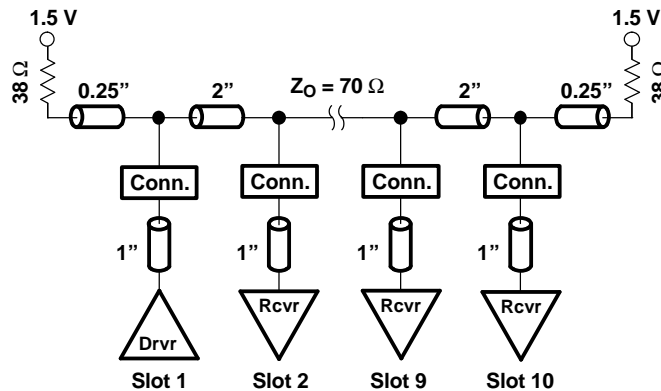

Figure 2. Medium-Drive Test Backplane

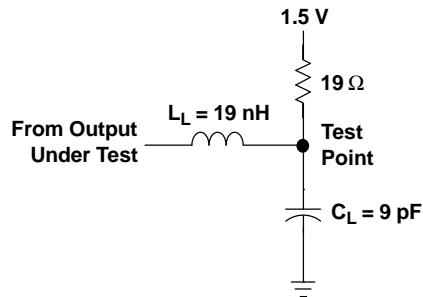

Figure 3. Medium-Drive RLC Network

SN74GTLP817
GTLP-TO-LVTTL 1-TO-6 FANOUT DRIVER

SCES285E—OCTOBER 1999—REVISED APRIL 2005

Switching Characteristics

over recommended ranges of supply voltage and operating free-air temperature,
 $V_{TT} = 1.5\text{ V}$ and $V_{REF} = 1\text{ V}$ for GTLP (see Figure 3)

PARAMETER	FROM (INPUT)	TO (OUTPUT)	EDGE RATE ⁽¹⁾	TYP ⁽²⁾	UNIT
t_{PLH}	AI	BO	Slow	4.4	ns
t_{PHL}				4.4	
t_{PLH}	AI	BO	Fast	3.2	ns
t_{PHL}				3.2	
t_{en}	\overline{OEAB}	BO	Slow	4	ns
t_{dis}				4.4	
t_{en}	\overline{OEAB}	BO	Fast	2.9	ns
t_{dis}				3.1	
t_r	Rise time, B outputs (20% to 80%)		Slow	1.8	ns
			Fast	1	
t_f	Fall time, B outputs (80% to 20%)		Slow	2	ns
			Fast	1.6	

(1) Slow (ERC = V_{CC}) and Fast (ERC = GND)

(2) All typical values are at $V_{CC} = 3.3\text{ V}$, $T_A = 25^\circ\text{C}$. All values are derived from TI-SPICE models.

PACKAGING INFORMATION

Orderable Device	Status (1)	Package Type	Package Drawing	Pins	Package Qty	Eco Plan (2)	Lead finish/ Ball material (6)	MSL Peak Temp (3)	Op Temp (°C)	Device Marking (4/5)	Samples
SN74GTL817PW	ACTIVE	TSSOP	PW	24	60	RoHS & Green	NIPDAU	Level-1-260C-UNLIM	-40 to 85	GT817	Samples

(1) The marketing status values are defined as follows:

ACTIVE: Product device recommended for new designs.

LIFEBUY: TI has announced that the device will be discontinued, and a lifetime-buy period is in effect.

NRND: Not recommended for new designs. Device is in production to support existing customers, but TI does not recommend using this part in a new design.

PREVIEW: Device has been announced but is not in production. Samples may or may not be available.

OBSOLETE: TI has discontinued the production of the device.

(2) **RoHS:** TI defines "RoHS" to mean semiconductor products that are compliant with the current EU RoHS requirements for all 10 RoHS substances, including the requirement that RoHS substance do not exceed 0.1% by weight in homogeneous materials. Where designed to be soldered at high temperatures, "RoHS" products are suitable for use in specified lead-free processes. TI may reference these types of products as "Pb-Free".

RoHS Exempt: TI defines "RoHS Exempt" to mean products that contain lead but are compliant with EU RoHS pursuant to a specific EU RoHS exemption.

Green: TI defines "Green" to mean the content of Chlorine (Cl) and Bromine (Br) based flame retardants meet JS709B low halogen requirements of <=1000ppm threshold. Antimony trioxide based flame retardants must also meet the <=1000ppm threshold requirement.

(3) MSL, Peak Temp. - The Moisture Sensitivity Level rating according to the JEDEC industry standard classifications, and peak solder temperature.

(4) There may be additional marking, which relates to the logo, the lot trace code information, or the environmental category on the device.

(5) Multiple Device Markings will be inside parentheses. Only one Device Marking contained in parentheses and separated by a "-" will appear on a device. If a line is indented then it is a continuation of the previous line and the two combined represent the entire Device Marking for that device.

(6) Lead finish/Ball material - Orderable Devices may have multiple material finish options. Finish options are separated by a vertical ruled line. Lead finish/Ball material values may wrap to two lines if the finish value exceeds the maximum column width.

Important Information and Disclaimer: The information provided on this page represents TI's knowledge and belief as of the date that it is provided. TI bases its knowledge and belief on information provided by third parties, and makes no representation or warranty as to the accuracy of such information. Efforts are underway to better integrate information from third parties. TI has taken and continues to take reasonable steps to provide representative and accurate information but may not have conducted destructive testing or chemical analysis on incoming materials and chemicals. TI and TI suppliers consider certain information to be proprietary, and thus CAS numbers and other limited information may not be available for release.

In no event shall TI's liability arising out of such information exceed the total purchase price of the TI part(s) at issue in this document sold by TI to Customer on an annual basis.

TUBE

*All dimensions are nominal

Device	Package Name	Package Type	Pins	SPQ	L (mm)	W (mm)	T (μm)	B (mm)
SN74GTLP817PW	PW	TSSOP	24	60	530	10.2	3600	3.5

PW0024A



PACKAGE OUTLINE

TSSOP - 1.2 mm max height

SMALL OUTLINE PACKAGE

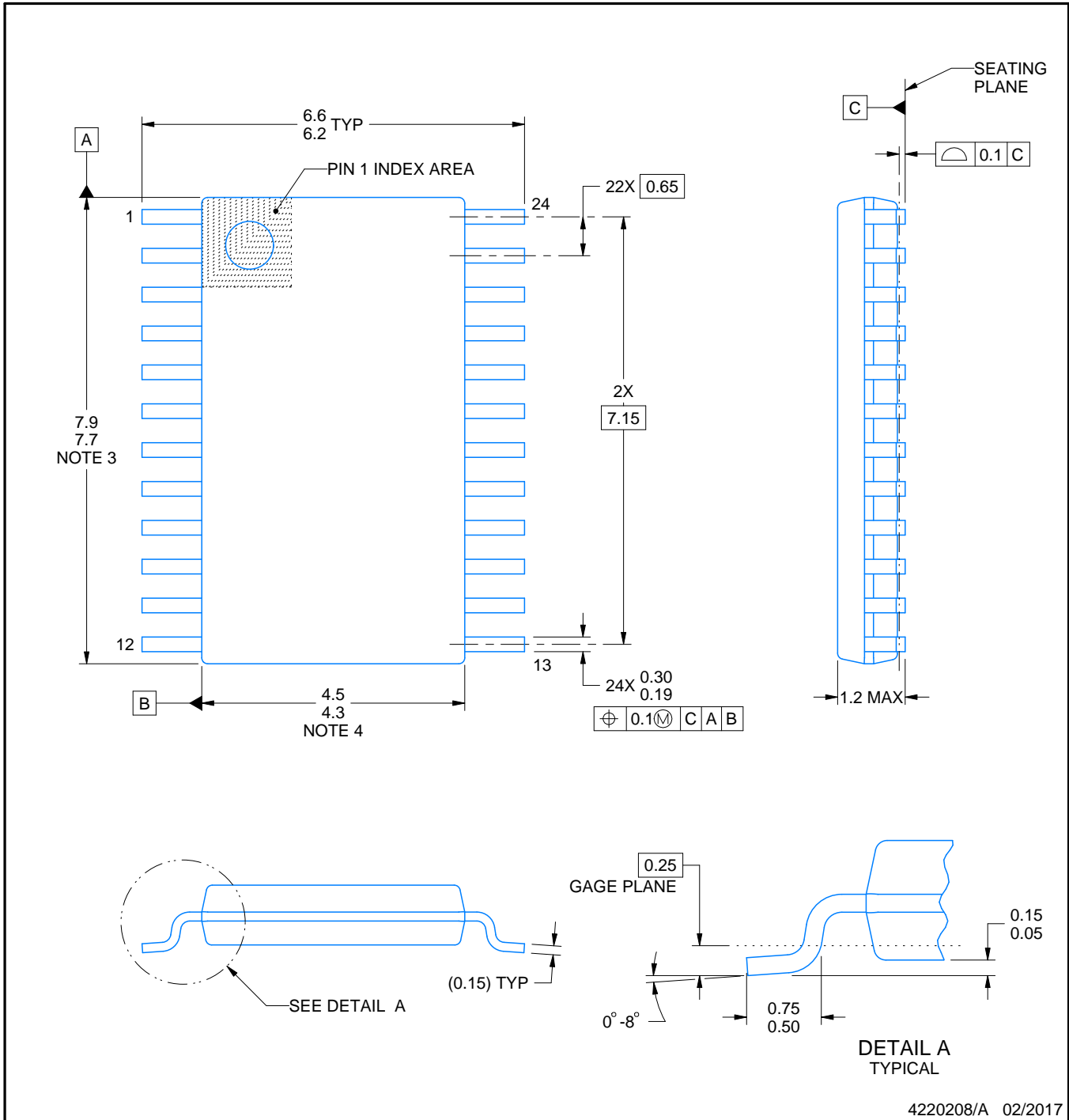

4220208/A 02/2017

NOTES:

1. All linear dimensions are in millimeters. Any dimensions in parenthesis are for reference only. Dimensioning and tolerancing per ASME Y14.5M.
2. This drawing is subject to change without notice.
3. This dimension does not include mold flash, protrusions, or gate burrs. Mold flash, protrusions, or gate burrs shall not exceed 0.15 mm per side.
4. This dimension does not include interlead flash. Interlead flash shall not exceed 0.25 mm per side.
5. Reference JEDEC registration MO-153.

EXAMPLE BOARD LAYOUT

PW0024A

TSSOP - 1.2 mm max height

SMALL OUTLINE PACKAGE



LAND PATTERN EXAMPLE
EXPOSED METAL SHOWN
SCALE: 10X

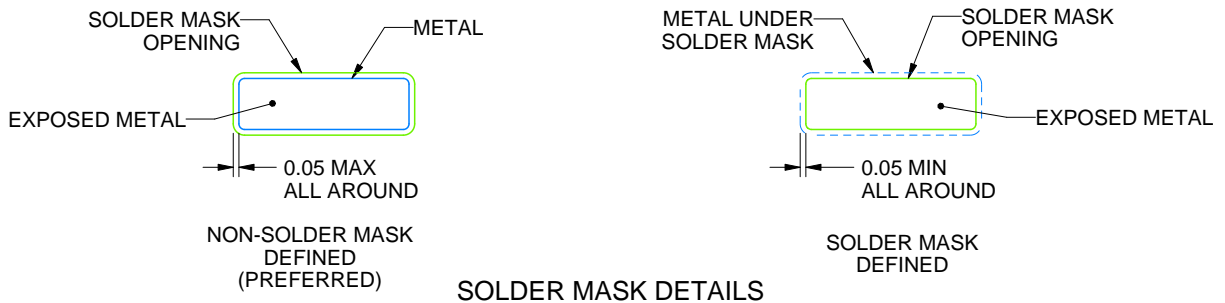

SOLDER MASK DETAILS

4220208/A 02/2017

NOTES: (continued)

- 6. Publication IPC-7351 may have alternate designs.
- 7. Solder mask tolerances between and around signal pads can vary based on board fabrication site.

EXAMPLE STENCIL DESIGN

PW0024A

TSSOP - 1.2 mm max height

SMALL OUTLINE PACKAGE



NOTES: (continued)

8. Laser cutting apertures with trapezoidal walls and rounded corners may offer better paste release. IPC-7525 may have alternate design recommendations.
9. Board assembly site may have different recommendations for stencil design.

IMPORTANT NOTICE AND DISCLAIMER

TI PROVIDES TECHNICAL AND RELIABILITY DATA (INCLUDING DATA SHEETS), DESIGN RESOURCES (INCLUDING REFERENCE DESIGNS), APPLICATION OR OTHER DESIGN ADVICE, WEB TOOLS, SAFETY INFORMATION, AND OTHER RESOURCES "AS IS" AND WITH ALL FAULTS, AND DISCLAIMS ALL WARRANTIES, EXPRESS AND IMPLIED, INCLUDING WITHOUT LIMITATION ANY IMPLIED WARRANTIES OF MERCHANTABILITY, FITNESS FOR A PARTICULAR PURPOSE OR NON-INFRINGEMENT OF THIRD PARTY INTELLECTUAL PROPERTY RIGHTS.

These resources are intended for skilled developers designing with TI products. You are solely responsible for (1) selecting the appropriate TI products for your application, (2) designing, validating and testing your application, and (3) ensuring your application meets applicable standards, and any other safety, security, regulatory or other requirements.

These resources are subject to change without notice. TI grants you permission to use these resources only for development of an application that uses the TI products described in the resource. Other reproduction and display of these resources is prohibited. No license is granted to any other TI intellectual property right or to any third party intellectual property right. TI disclaims responsibility for, and you will fully indemnify TI and its representatives against, any claims, damages, costs, losses, and liabilities arising out of your use of these resources.

TI's products are provided subject to [TI's Terms of Sale](#) or other applicable terms available either on ti.com or provided in conjunction with such TI products. TI's provision of these resources does not expand or otherwise alter TI's applicable warranties or warranty disclaimers for TI products.

TI objects to and rejects any additional or different terms you may have proposed.

Mailing Address: Texas Instruments, Post Office Box 655303, Dallas, Texas 75265
Copyright © 2022, Texas Instruments Incorporated

Looking for pricing, stock, or lifecycle information?

Click below to explore more details on WIN SOURCE:

 [View SN74GTLP817PWR on WIN SOURCE](#)

 [Texas Instruments](#) Information

Optimize Your Supply Chain with WIN SOURCE Solutions

-  Global Sourcing Solution
-  Obsolete Management
-  Cost Control Management
-  Shortage Management
-  Alternative Solution
-  Excess Inventory Management