

Features

- High Dynamic Range: 42dB Typical
- Flat Attenuation vs. Frequency
- High P1dB Compression
- Operates on a Single +5V Supply:
- 50 Ohm Nominal Impedance
- Lead-Free SOW-16 Package
- 100% Matte Tin Plating over Copper
- Halogen-Free "Green" Mold Compound
- 260°C Reflow Compatible
- RoHS* Compliant Version of AT10-0019

Description

M/A-COM's MAAV-007088-000100 is a Voltage Controlled PIN diode based π attenuator packaged in a low cost, 16 lead wide body plastic SMT package. The PIN diode design makes this part well suited for applications where low distortion or high linear operating power levels are required. These attenuators are ideal for gain control in multi-channel digital communications systems.

Functional Schematic

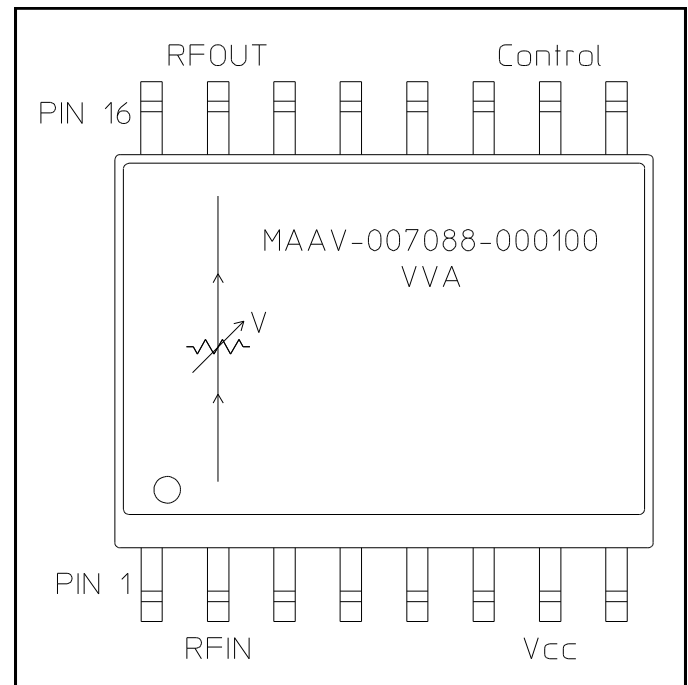

Ordering Information

Part Number	Package
MAAV-007088-000100	Bulk Packaging
MAAV-007088-0001TR	1000 piece reel
MAAV-007088-0001TB	Sample Test Board

Note: Reference Application Note M513 for reel size information.

Pin Configuration

Pin No.	Function	Pin No.	Function
1	GND	9	GND
2	RF IN	10	V CONTROL
3	GND	11	GND
4	GND	12	GND
5	GND	13	GND
6	GND	14	GND
7	V SUPPLY	15	RF OUT
8	GND	16	GND

* Restrictions on Hazardous Substances, European Union Directive 2002/95/EC.

PIN Diode Based Variable Attenuator, 50 - 1000 MHz

Rev. V2

Electrical Specifications: $T_A = 25^\circ\text{C}$, $Z_0 = 50\Omega^1$

Parameter	Test Conditions	Frequency	Units	Min	Typ	Max
Insertion Loss	Vcont.: +10 V	50 - 1000 MHz	dB	—	2.4	2.8
Dynamic Range	Vcont.: 0 V	50 - 1000 MHz	dB	33	42	—
Attenuation Flatness	Attenuation: 0 to 20 dB Attenuation: 20 to 30 dB	50 - 1000 MHz	dB	—	1.0	1.5
		50 - 1000 MHz	dB	—	1.5	2.0
VSWR	Vcont.: 0 - 10V	50 - 1000 MHz	Ratio	—	1.7:1	2.1:1
Trise, Tfall Ton, Toff Transients	10%/90%, 90%/10% 50% Cntl to 90%/10% RF In-band	—	μs	—	10	20
		—	μs	—	15	25
		—	mV	—	150	250
1 dB Compression	Vcont.: 0 - 10V	100 MHz	dBm	10	13	—
		500 MHz	dBm	17	20	—
		1000 MHz	dBm	21	24	—
Input IP ₃	Vcont.: 0 - 10V Two-tone inputs up to +10 dBm	100 MHz	dBm	24	27	—
		1000 MHz	dBm	34	37	—
V _{CC}	—	—	V	+4.75	+5.0	+5.25
I _{CC}	V _{CC} = 5.25 V	DC	mA	—	2	2.5
Control Current	—	DC	mA	—	2.7	3.5

- Unit requires external .01 μF DC Blocks on RF lines.

Absolute Maximum Ratings ^{2,3}

Parameter	Absolute Maximum
Max. Input Power 50 - 500 MHz 500 - 1000 MHz	+24 dBm +30 dBm
Voltages V _{CC} Control Voltage	-1 V to +7.0 V -1 V to +15 V
Operating Temperature	-40°C to +85°C
Storage Temperature	-65°C to +125°C

- Exceeding any one or combination of these limits may cause permanent damage to this device.
- M/A-COM does not recommend sustained operation near these survivability limits.

Handling Procedures

Please observe the following precautions to avoid damage:

Static Sensitivity

Gallium Arsenide Integrated Circuits are sensitive to electrostatic discharge (ESD) and can be damaged by static electricity. Proper ESD control techniques should be used when handling these devices.

Pad Layout

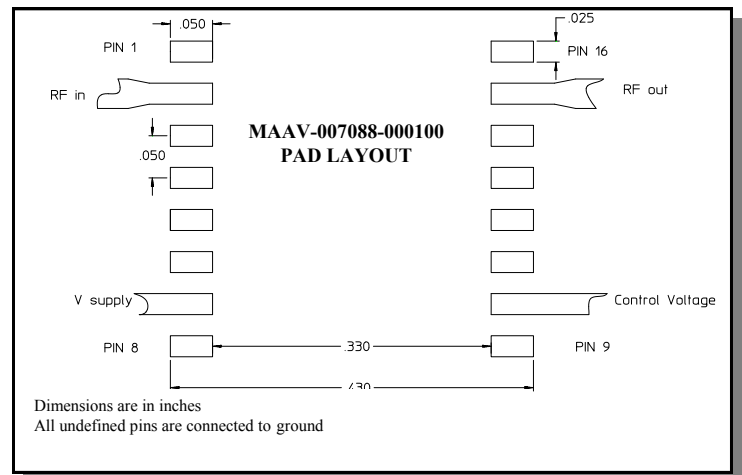

Typical Performance Curves

Attenuation vs. Frequency @ Control Voltage = 0V

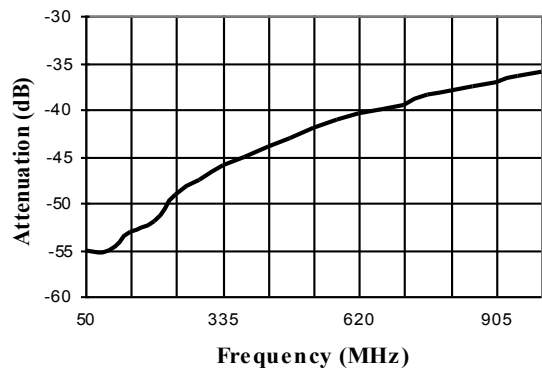

Attenuation vs. Control Voltage @ 500 MHz

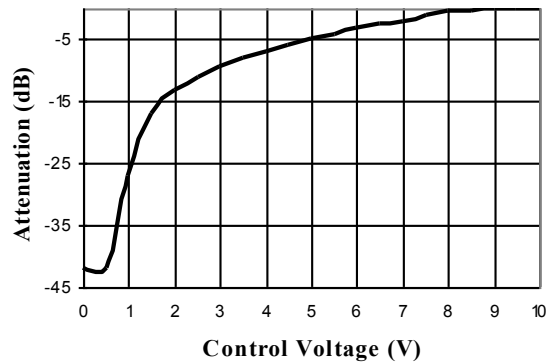

Insertion Loss vs. Frequency @ Control Voltage = 10V

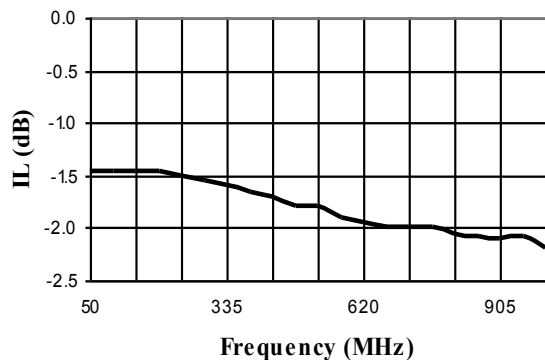

PIN Diode Based Variable Attenuator, 50 - 1000 MHz

Rev. V2

Lead-Free, SOW-16[†]

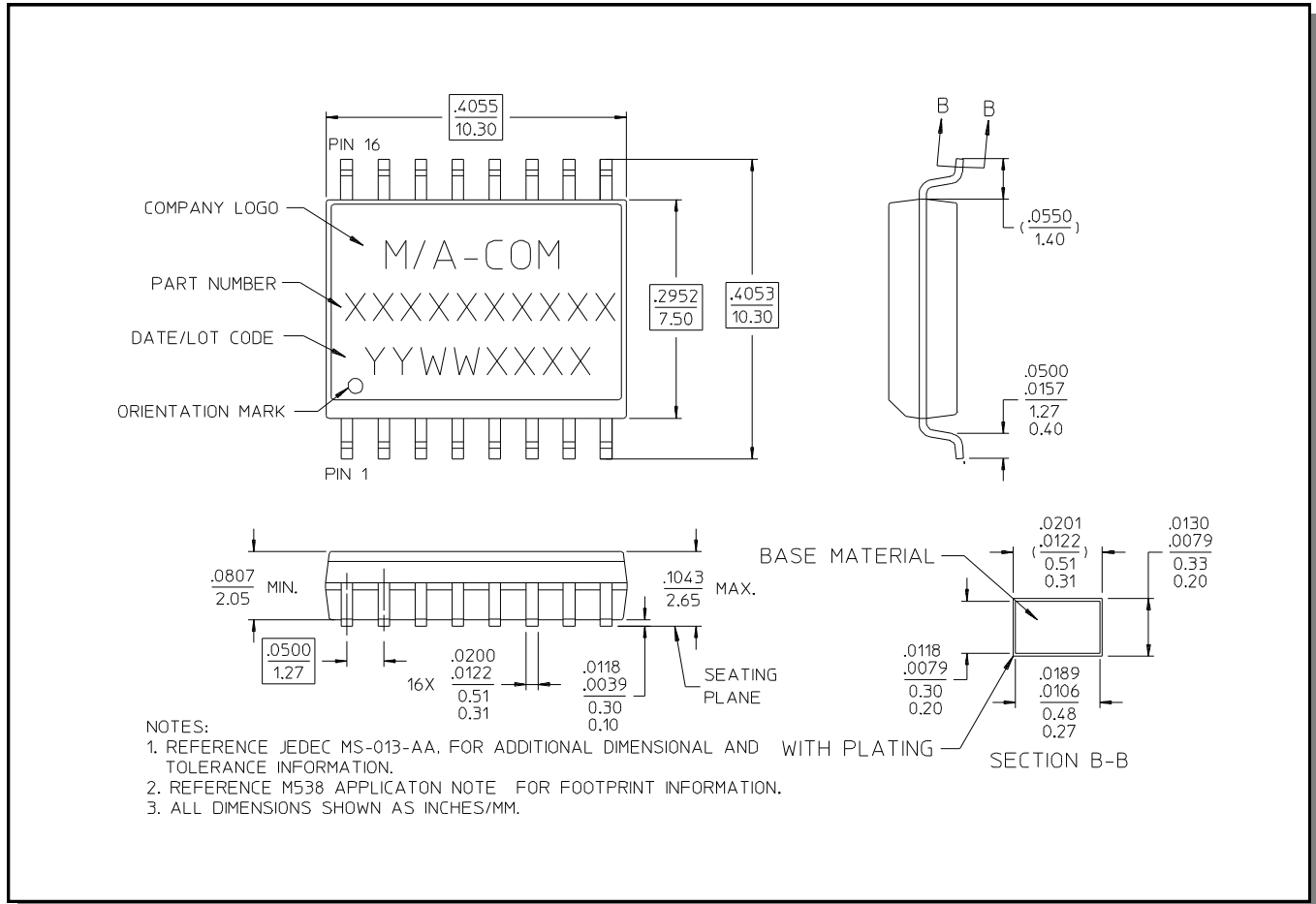

[†] Reference Application Note M538 for lead-free solder reflow recommendations.

M/A-COM Technology Solutions Inc. All rights reserved.

Information in this document is provided in connection with M/A-COM Technology Solutions Inc ("MACOM") products. These materials are provided by MACOM as a service to its customers and may be used for informational purposes only. Except as provided in MACOM's Terms and Conditions of Sale for such products or in any separate agreement related to this document, MACOM assumes no liability whatsoever. MACOM assumes no responsibility for errors or omissions in these materials. MACOM may make changes to specifications and product descriptions at any time, without notice. MACOM makes no commitment to update the information and shall have no responsibility whatsoever for conflicts or incompatibilities arising from future changes to its specifications and product descriptions. No license, express or implied, by estoppel or otherwise, to any intellectual property rights is granted by this document.

THESE MATERIALS ARE PROVIDED "AS IS" WITHOUT WARRANTY OF ANY KIND, EITHER EXPRESS OR IMPLIED, RELATING TO SALE AND/OR USE OF MACOM PRODUCTS INCLUDING LIABILITY OR WARRANTIES RELATING TO FITNESS FOR A PARTICULAR PURPOSE, CONSEQUENTIAL OR INCIDENTAL DAMAGES, MERCHANTABILITY, OR INFRINGEMENT OF ANY PATENT, COPYRIGHT OR OTHER INTELLECTUAL PROPERTY RIGHT. MACOM FURTHER DOES NOT WARRANT THE ACCURACY OR COMPLETENESS OF THE INFORMATION, TEXT, GRAPHICS OR OTHER ITEMS CONTAINED WITHIN THESE MATERIALS. MACOM SHALL NOT BE LIABLE FOR ANY SPECIAL, INDIRECT, INCIDENTAL, OR CONSEQUENTIAL DAMAGES, INCLUDING WITHOUT LIMITATION, LOST REVENUES OR LOST PROFITS, WHICH MAY RESULT FROM THE USE OF THESE MATERIALS.

MACOM products are not intended for use in medical, lifesaving or life sustaining applications. MACOM customers using or selling MACOM products for use in such applications do so at their own risk and agree to fully indemnify MACOM for any damages resulting from such improper use or sale.

Looking for pricing, stock, or lifecycle information?

Click below to explore more details on WIN SOURCE:

- ⊖ [View MAAV-007088-000100 on WIN SOURCE](#)
- ⊖ [M/A-Com Technology Solutions Information](#)

Optimize Your Supply Chain with WIN SOURCE Solutions

- ✓ Global Sourcing Solution
- ✓ Obsolete Management
- ✓ Cost Control Management
- ✓ Shortage Management
- ✓ Alternative Solution
- ✓ Excess Inventory Management