



**THE DATASHEET OF
CY8C26443-24PVXI**



Not Recommended for New Designs: Use CY8C27xxx



**Configurable
Mixed-Signal Array
with On-board Controller**

**CY8C25122, CY8C26233, CY8C26443, CY8C26643
Device Data Sheet for Silicon Revision D**

Programmable System-on-Chip (PSoC™)

Getting Started in the PSoC World!

The award winning PSoC Designer software and PSoC silicon are an integrated unit. The quickest path to understanding the PSoC silicon is through the PSoC Designer software GUI. This data sheet is useful for understanding the details of the PSOC integrated circuit, but is not a good starting point for a new PSoC developer seeking to get a general overview of this new technology.

PSoC developers are NOT required to build their own ADCs, DACs, and other peripherals. Embedded in the PSoC Designer software are the individual data sheets, performance graphs, and PSoC User Modules (graphically selected code packets) for the peripherals, such as the incremental ADCs, DACs, LCD controllers, op amps, low-pass filters, etc. **With simple GUI-based selection, placement, and connection, the basic architecture of a design may be developed within PSoC Designer software without ever writing a single line of code.**

Development Kits are available from the following distributors: Digi-Key, Avnet, Arrow, and Future. The Cypress Online Store also contains development kits, C compilers, and all accessories for PSoC development. Go to the Cypress Online Store web site at <http://www.cypress.com>, click the Online Store shopping cart icon at the bottom of the web page, and click *PSoC (Programmable System-on-Chip)* to view a current list of available items.

Free PSoC technical training is available for beginners and is taught by a marketing or application engineer over the phone. PSoC training classes cover designing, debugging, advanced analog, as well as application-specific classes covering topics such as PSoC and the LIN bus. Go to <http://www.cypress.com>, click on Design Support located on the left side of the web page, and select Technical Training for more details.

Certified PSoC Consultants offer everything from technical assistance to completed PSoC designs. To contact or become a PSoC Consultant go to <http://www.cypress.com>, click on Design Support located on the left side of the web page, and select CYPros Consultants.

PSoC application engineers take pride in fast and accurate response. They can be reached with a 4-hour guaranteed response at <http://www.cypress.com/support/login.cfm>.

Cypress Semiconductor
2700 162nd Street SW, Building D
Lynnwood, WA 98037
Phone: 425.787.4400
Fax: 425.787.4641
Application Support Hotline: 425.787.4814

© Cypress Semiconductor Corporation. 2000-2005. All rights reserved. PSoC™, PSoC Designer™, and Programmable System-on-Chip™ are PSoC-related trademarks of Cypress Semiconductor Corporation. All other trademarks or registered trademarks referenced herein are property of the respective corporations.

The information contained herein is subject to change without notice. Cypress Semiconductor assumes no responsibility for the use of any circuitry other than circuitry embodied in a Cypress Semiconductor product. Nor does it convey or imply any license under patent or other rights. Cypress Semiconductor does not authorize its products for use as critical components in life-support systems where a malfunction or failure may reasonably be expected to result in significant injury to the user. The inclusion of Cypress Semiconductor products in life-support systems application implies that the manufacturer assumes all risk of such use and in doing so indemnifies Cypress Semiconductor against all charges. Cypress Semiconductor products are not warranted nor intended to be used for medical, life-support, life-saving, critical control or safety applications, unless pursuant to an express written agreement with Cypress Semiconductor.

Note the following details of the Flash code protection features on Cypress Semiconductor PSoC devices.

Cypress Semiconductor products meet the specifications contained in their particular Cypress Semiconductor Data Sheets. Cypress Semiconductor believes that its family of products is one of the most secure families of its kind on the market today, regardless of how they are used. There may be methods, unknown to Cypress Semiconductor, that can breach the code protection features. Any of these methods, to our knowledge, would be dishonest and possibly illegal. Neither Cypress Semiconductor nor any other semiconductor manufacturer can guarantee the security of their code. Code protection does not mean that we are guaranteeing the product as "unbreakable." Cypress Semiconductor is willing to work with the customer who is concerned about the integrity of their code. Code protection is constantly evolving. We at Cypress Semiconductor are committed to continuously improving the code protection features of our products.

The PSoC™ CY8C25122/CY8C26233/CY8C26443/CY8C26643 family of programmable system-on-chip devices replace multiple MCU-based system components with one single-chip, configurable device. A PSoC device includes configurable analog and digital peripheral blocks, a fast CPU, Flash program memory, and SRAM data memory in a range of convenient pin-outs and memory sizes. The driving force behind this innovative programmable system-on-chip comes from user configurability of the analog and digital arrays: the PSoC blocks.

Programmable System-on-Chip (PSoC™) Blocks

- On-chip, user configurable analog and digital peripheral blocks
- PSoC blocks can be used individually or in combination
- 12 Analog PSoC blocks provide:
 - Up to 11-bit Delta-Sigma ADC
 - Up to 8-bit Successive Approximation ADC
 - Up to 12-bit Incremental ADC
 - Up to 9-bit DAC
 - Programmable gain amplifier
 - Programmable filters
 - Differential comparators
- 8 Digital PSoC blocks provide:
 - Multipurpose timers: event timing, real-time clock, pulse width modulation (PWM) and PWM with deadband
 - CRC modules
 - Full-duplex UARTs
 - SPI™ master or slave configuration
 - Flexible clocking sources for analog PSoC blocks

Powerful Harvard Architecture Processor with Fast Multiply/Accumulate

- M8C processor instruction set
- Processor speeds to 24 MHz
- Register speed memory transfers
- Flexible addressing modes
- Bit manipulation on I/O and memory
- 8x8 multiply, 32-bit accumulate

Flexible On-Chip Memory

- Flash program storage, 4K to 16K bytes, depending on device
- 50,000 erase/write cycles
- 256 bytes SRAM data storage
- In-System Serial Programming (ISSP™)

- Partial Flash updates
- Flexible protection modes
- EEPROM emulation in Flash, up to 2,304 bytes

Programmable Pin Configurations

- Schmitt trigger TTL I/O pins
- Logic output drive to 25 mA with internal pull-up or pull-down resistors, High Z, or strong driver
- Interrupt on pin change
- Analog output drive to 40 mA

Precision, Programmable Clocking

- Internal 24/48 MHz Oscillator (+/- 2.5%, no external components)
- External 32.768 kHz Crystal Oscillator (optional precision source for PLL)
- Internal Low Speed Oscillator for Watchdog and Sleep

Dedicated Peripherals

- Watchdog and Sleep Timers
- Low Voltage Detection with user-configurable threshold voltages
- On-chip voltage reference

Fully Static CMOS Devices using advanced Flash technology

- Low power at high speed
- Operating voltage from 3.0 to 5.25 V
- Operating voltage down to 1.0 V using on-chip switch mode voltage pump
- Wide temperature range: -40 °C to + 85 °C

Complete Development Tools

- Powerful integrated development environment (PSoC™ Designer)
- Low-cost, in-circuit emulator and programmer

This page has intentionally been left blank.

Table of Contents

1.0 Functional Overview	14
1.1 Key Features	14
1.2 Pin-out Descriptions	15
2.0 CPU Architecture	19
2.1 Introduction	19
2.2 CPU Registers	20
2.3 Addressing Modes	21
2.4 Instruction Set Summary	25
3.0 Memory Organization	26
3.1 Flash Program Memory Organization	26
3.2 RAM Data Memory Organization	26
4.0 Register Organization	26
4.1 Introduction	26
4.2 Register Bank 0 Map	27
4.3 Register Bank 1 Map	28
5.0 I/O Ports	29
5.1 Introduction	29
6.0 I/O Registers	31
6.1 Port Data Registers	31
6.2 Port Interrupt Enable Registers	31
6.3 Port Global Select Registers	32
7.0 Clocking	35
7.1 Oscillator Options	35
7.2 System Clocking Signals	38
8.0 Interrupts	42
8.1 Overview	42
8.2 Interrupt Control Architecture	44
8.3 Interrupt Vectors	44
8.4 Interrupt Masks	45
8.5 Interrupt Vector Register	46
8.6 GPIO Interrupt	47
9.0 Digital PSoC Blocks	48
9.1 Introduction	48
9.2 Digital PSoC Block Bank 1 Registers	49
9.3 Digital PSoC Block Bank 0 Registers	54
9.4 Global Inputs and Outputs	60
9.5 Available Programmed Digital Functionality	60
10.0 Analog PSoC Blocks	71
10.1 Introduction	71
10.2 Analog System Clocking Signals	72
10.3 Array of Analog PSoC Blocks	72
10.4 Analog Reference Control	73
10.5 Analog PSoC Block Clocking Options	76
10.6 Analog Clock Select Register	77
10.7 Analog Continuous Time PSoC Blocks	80

10.8 Analog Switch Cap Type A PSoC Blocks	85
10.9 Analog Switch Cap Type B PSoC Blocks	94
10.10 Analog Comparator Bus	101
10.11 Analog Synchronization	101
10.12 Analog I/O	103
10.13 Analog Modulator	106
10.14 Analog PSoC Block Functionality	107
10.15 Temperature Sensing Capability	108
11.0 Special Features of the CPU	109
11.1 Multiplier/Accumulator	109
11.2 Decimator	112
11.3 Reset	114
11.4 Sleep States	116
11.5 Supply Voltage Monitor	118
11.6 Switch Mode Pump	119
11.7 Internal Voltage Reference	120
11.8 Supervisor ROM/System Supervisor Call Instruction	120
11.9 Flash Program Memory Protection	122
11.10 Programming Requirements and Step Descriptions	122
11.11 Programming Wave Forms	124
11.12 Programming File Format	124
12.0 Development Tools	125
12.1 Overview	125
12.2 Integrated Development Environment Subsystems	126
12.3 Hardware Tools	126
13.0 DC and AC Characteristics	127
13.1 Absolute Maximum Ratings	127
13.2 DC Characteristics	129
13.3 AC Characteristics	138
14.0 Packaging Information	143
14.1 Thermal Impedances per Package	148
15.0 Ordering Guide	149
16.0 Document Revision History	150

List of Tables

Table 1: Device Family Key Features.....	14
Table 2: Pin-out 8 Pin	15
Table 3: Pin-out 20 Pin	15
Table 4: Pin-out 28 Pin	16
Table 5: Pin-out 44 Pin	16
Table 6: Pin-out 48 Pin	17
Table 7: CPU Registers and Mnemonics	19
Table 8: Flags Register	20
Table 9: Accumulator Register (CPU_A)	20
Table 10: Index Register (CPU_X).....	21
Table 11: Stack Pointer Register (CPU_SP).....	21
Table 12: Program Counter Register (CPU_PC).....	21
Table 13: Source Immediate	21
Table 14: Source Direct.....	22
Table 15: Source Indexed	22
Table 16: Destination Direct	22
Table 17: Destination Indexed.....	23
Table 18: Destination Direct Immediate	23
Table 19: Destination Indexed Immediate	23
Table 20: Destination Direct Direct.....	24
Table 21: Source Indirect Post Increment	24
Table 22: Destination Indirect Post Increment.....	24
Table 23: Instruction Set Summary (Sorted by Mnemonic).....	25
Table 24: Flash Program Memory Map	26
Table 25: RAM Data Memory Map	26
Table 26: Bank 0	27
Table 27: Bank 1	28
Table 28: Port Data Registers	31
Table 29: Port Interrupt Enable Registers	31
Table 30: Port Global Select Registers	32
Table 31: Port Drive Mode 0 Registers	32
Table 32: Port Drive Mode 1 Registers	33
Table 33: Port Interrupt Control 0 Registers.....	33
Table 34: Port Interrupt Control 1 Registers.....	34
Table 35: Internal Main Oscillator Trim Register	35
Table 36: Internal Low Speed Oscillator Trim Register	36
Table 37: External Crystal Oscillator Trim Register.....	37
Table 38: Typical Package Capacitances	37
Table 39: System Clocking Signals and Definitions	38
Table 40: Oscillator Control 0 Register.....	40
Table 41: Oscillator Control 1 Register.....	40
Table 42: 24V1/24V2 Frequency Selection	41
Table 43: Interrupt Vector Table.....	44
Table 44: General Interrupt Mask Register	45
Table 45: Digital PSoC Block Interrupt Mask Register	46

Table 46: Interrupt Vector Register	46
Table 47: Digital Basic Type A/ Communications Type A Block xx Function Register.....	50
Table 48: Digital Basic Type A / Communications Type A Block xx Input Register	51
Table 49: Digital Function Data Input Definitions	52
Table 50: Digital Basic Type A / Communications Type A Block xx Output Register.....	53
Table 51: Digital Function Outputs	54
Table 52: Digital Basic Type A / Communications Type A Block xx Data Register 0,1,2.....	54
Table 53: R/W Variations per User Module Selection	55
Table 54: Digital Basic Type A / Communications Type A Block xx Control Register 0.....	55
Table 55: Digital Basic Type A/Communications Type A Block xx Control Register 0.....	56
Table 56: Digital Communications Type A Block xx Control Register 0.....	57
Table 57: Digital Communications Type A Block xx Control Register 0.....	58
Table 58: Digital Communications Type A Block xx Control Register 0.....	59
Table 59: Global Input Assignments.....	60
Table 60: Global Output Assignments.....	60
Table 61: Analog System Clocking Signals.....	72
Table 62: AGND, RefHI, RefLO Operating Parameters	74
Table 63: Analog Reference Control Register.....	75
Table 64: Analog Column Clock Select Register.....	76
Table 65: Analog Clock Select Register	77
Table 66: Analog Continuous Time Block xx Control 0 Register.....	82
Table 67: Analog Continuous Time Block xx Control 1 Register.....	83
Table 68: Analog Continuous Time Type A Block xx Control 2 Register	84
Table 69: Analog Switch Cap Type A Block xx Control 0 Register	88
Table 70: Analog Switch Cap Type A Block xx Control 1 Register	90
Table 71: Analog Switch Cap Type A Block xx Control 2 Register	92
Table 72: Analog Switch Cap Type A Block xx Control 3 Register	93
Table 73: Analog Switch Cap Type B Block xx Control 0 Register	95
Table 74: Analog Switch Cap Type B Block xx Control 1 Register	97
Table 75: Analog Switch Cap Type B Block xx Control 2 Register	99
Table 76: Analog Switch Cap Type B Block xx Control 3 Register	100
Table 77: Analog Comparator Control Register	101
Table 78: Analog Frequency Relationships.....	102
Table 79: Analog Synchronization Control Register.....	102
Table 80: Analog Input Select Register	104
Table 81: Analog Output Buffer Control Register	106
Table 82: Analog Modulator Control Register	107
Table 83: Multiply Input X Register.....	110
Table 84: Multiply Input Y Register.....	110
Table 85: Multiply Result High Register	111
Table 86: Multiply Result Low Register	111
Table 87: Accumulator Result 1 / Multiply/Accumulator Input X Register	111
Table 88: Accumulator Result 0 / Multiply/Accumulator Input Y Register	111
Table 89: Accumulator Result 3 / Multiply/Accumulator Clear 0 Register	112
Table 90: Accumulator Result 2 / Multiply/Accumulator Clear 1 Register	112
Table 91: Decimator/Incremental Control Register	113
Table 92: Decimator Data High Register.....	113
Table 93: Decimator Data Low Register.....	113
Table 94: Processor Status and Control Register	114
Table 95: Reset WDT Register.....	116
Table 96: Voltage Monitor Control Register	118
Table 97: Bandgap Trim Register.....	120
Table 98: CY8C25122, CY8C26233, CY8C26443, CY8C26643 (256 Bytes of SRAM)	121
Table 99: Table Read for Supervisory Call Functions	122

Table 100: Flash Program Memory Protection	122
Table 101: Programmer Requirements	122
Table 102: Absolute Maximum Ratings	127
Table 103: Temperature Specifications	128
Table 104: DC Operating Specifications	129
Table 105: 5V DC Operational Amplifier Specifications	130
Table 106: 3.3V DC Operational Amplifier Specifications	131
Table 107: DC Analog Input Pin with Multiplexer Specifications	132
Table 108: DC Analog Input Pin to SC Block Specifications	132
Table 109: 5V DC Analog Output Buffer Specifications	132
Table 110: 3.3V DC Analog Output Buffer Specifications	133
Table 111: DC Switch Mode Pump Specifications	134
Table 112: 5V DC Analog Reference Specifications	135
Table 113: 3.3V DC Analog Reference Specifications	136
Table 114: DC Analog PSoC Block Specifications	136
Table 115: DC Programming Specifications	137
Table 116: AC Operating Specifications	138
Table 117: 5V AC Operational Amplifier Specifications	139
Table 118: 3.3V AC Operational Amplifier Specifications	140
Table 119: 5V AC Analog Output Buffer Specifications	141
Table 120: 3.3V AC Analog Output Buffer Specifications	142
Table 121: AC Programming Specifications	142
Table 122: Thermal Impedances	148
Table 123: Ordering Guide (Leaded)	149
Table 124: Ordering Guide (Pb-Free Denoted with an "X" in Ordering Code)	149
Table 125: Document Revision History	150

List of Figures

Figure 1: Block Diagram	13
Figure 2: CY8C25122	15
Figure 3: CY8C26233	15
Figure 4: 26443 PDIP/SOIC/SSOP	16
Figure 5: 26643 TQFP	17
Figure 6: 26643 PDIP/SSOP	18
Figure 7: General Purpose I/O Pins	30
Figure 8: External Crystal Oscillator Connections	37
Figure 9: PSoC MCU Clock Tree of Signals	39
Figure 10: Interrupts Overview	43
Figure 11: GPIO Interrupt Enable Diagram	47
Figure 12: Digital Basic and Digital Communications PSoC Blocks	49
Figure 13: Polynomial LFSR	65
Figure 14: Polynomial PRS	65
Figure 15: SPI Waveforms	68
Figure 16: Array of Analog PSoC Blocks	72
Figure 17: Analog Reference Control Schematic	73
Figure 18: NMux Connections	78
Figure 19: PMux Connections	79
Figure 20: RBotMux Connections	79
Figure 21: Analog Continuous Time PSoC Blocks	81
Figure 22: Analog Switch Cap Type A PSoC Blocks	86
Figure 23: AMux Connections	87
Figure 24: CMux Connections	87
Figure 25: BMuxSCA/SCB Connections	88
Figure 26: Analog Switch Cap Type B PSoC Blocks	95
Figure 27: Analog Input Muxing	103
Figure 28: Analog Output Buffers	105
Figure 29: Multiply/Accumulate Block Diagram	110
Figure 30: Decimator Coefficients	112
Figure 31: Execution Reset	115
Figure 32: Three Sleep States	117
Figure 33: Switch Mode Pump	119
Figure 34: Programming Wave Forms	124
Figure 35: PSoC Designer Functional Flow	125
Figure 36: CY8C25xxx/CY8C26xxx Voltage Frequency Graph	127
Figure 37: 44-Lead Thin Plastic Quad Flat Pack A44	143
Figure 38: 20-Pin Shrunken Small Outline Package O20	144
Figure 39: 28-Lead (210-Mil) Shrunken Small Outline Package O28	145
Figure 40: 48-Lead Shrunken Small Outline Package O48	145
Figure 41: 20-Lead (300-Mil) Molded DIP P5	146
Figure 42: 28-Lead (300-Mil) Molded DIP P21	146
Figure 43: 48-Lead (600-Mil) Molded DIP P25	147
Figure 44: 20-Lead (300-Mil) Molded SOIC S5	147
Figure 45: 28-Lead (300-Mil) Molded SOIC S21	148

Figure 46: 8-Lead (300-Mil) Molded DIP 148

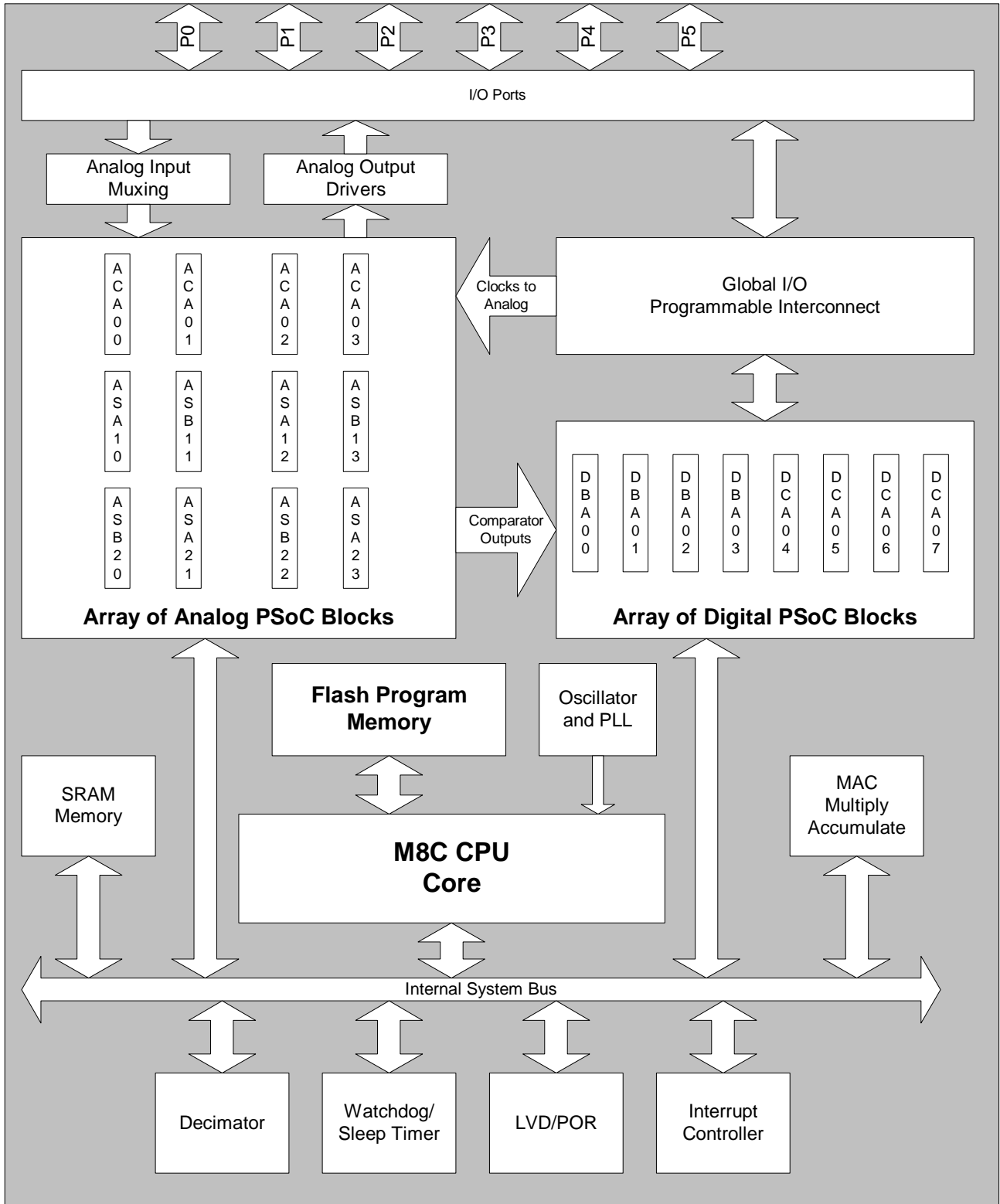

Figure 1: Block Diagram

1.0 Functional Overview

The CPU heart of this next generation family of micro-controllers is a high performance, 8-bit, M8C Harvard architecture microprocessor. Separate program and memory busses allow for faster overall throughput. Processor clock speeds to 24 MHz are available. The processor may also be run at lower clock speeds for power-sensitive applications. A rich instruction set allows for efficient low-level language support.

All devices in this family include both analog and digital configurable peripherals (PSoC blocks). These blocks enable the user to define unique functions during configuration of the device. Included are twelve analog PSoC blocks and eight digital PSoC blocks. Potential applications for the digital PSoC blocks are timers, counters, UARTs, CRC generators, PWMs, and other functions. The analog PSoC blocks can be used for SAR ADCs, Multi-slope ADCs, programmable gain amplifiers, programmable filters, DACs, and other functions. Higher order User Modules such as modems, complex motor controllers, and complete sensor signal chains can be created from these building blocks. This allows for an unprecedented level of flexibility and integration in micro-controller-based systems.

A Multiplier/Accumulator (MAC) is available on all devices in this family. The MAC is implemented on this device as a peripheral that is mapped into the register space. When an instruction writes to the MAC input registers, the result of an 8x8 multiply and a 32-bit accumulate are available to be read from the output registers on the next instruction cycle.

The number of general purpose I/Os available in this family of parts range from 6 to 44. Each of these I/O pins has a variety of programmable options. In the output

mode, the user can select the drive strength desired. Any pin can serve as an interrupt source, and can be selected to trigger on positive edges, negative edges, or any change. Digital signal sources can be routed directly from a pin to the digital PSoC blocks. Some pins have additional capability to route analog signals to the analog PSoC blocks.

Multiple oscillator options are available for use in clocking the CPU, analog PSoC blocks and digital PSoC blocks. These options include an internal main oscillator running at 48/24 MHz, an external crystal oscillator for use with a 32.768 kHz watch crystal, and an internal low-speed oscillator for use in clocking the PSoC blocks and the Watchdog/Sleep timer. User selectable clock divisors allow for optimizing code execution speed and power trade-offs.

The different device types in this family provide various amounts of code and data memory. The code space ranges in size from 4K to 16K bytes of user programmable Flash memory. This memory can be programmed serially in either a programming Pod or on the user board. The endurance on the Flash memory is 50,000 erase/write cycles. The data space is 256 bytes of user SRAM.

A powerful and flexible protection model secures the user's sensitive information. This model allows the user to selectively lock blocks of memory for read and write protection. This allows partial code updates without exposing proprietary information.

Devices in this family range from 8 pins through 48 pins in PDIP, SOIC and SSOP packages.

1.1 Key Features

Table 1: Device Family Key Features

	CY8C25122	CY8C26233	CY8C26443	CY8C26643
Operating Frequency	93.7kHz - 24MHz	93.7kHz - 24MHz	93.7kHz - 24MHz	93.7kHz - 24MHz
Operating Voltage	3.0 - 5.25V	3.0 - 5.25V	3.0 - 5.25V	3.0 - 5.25V
Program Memory (KBytes)	4	8	16	16
Data Memory (Bytes)	256	256	256	256
Digital PSoC Blocks	8	8	8	8
Analog PSoC Blocks	12	12	12	12
I/O Pins	6	16	24	40/44
External Switch Mode Pump	No	Yes	Yes	Yes
Available Packages	8 PDIP	20 PDIP	28 PDIP	48 PDIP
		20 SOIC	28 SOIC	48 SSOP
		20 SSOP	28 SSOP	44 TQFP

1.2 Pin-out Descriptions

Table 2: Pin-out 8 Pin

Name	I/O	Pin	Description
P0[7]	I/O	1	Port 0[7] (Analog Input)
P0[5]	I/O	2	Port 0[5] (Analog Input/Output)
P1[1]	I/O	3	Port 1[1] / XtalIn / SCLK
Vss	Power	4	Ground
P1[0]	I/O	5	Port 1[0] / XtalOut / SDATA
P0[2]	I/O	6	Port 0[2] (Analog Input/Output)
P0[4]	I/O	7	Port 0[4] (Analog Input/Output)
Vcc	Power	8	Supply Voltage

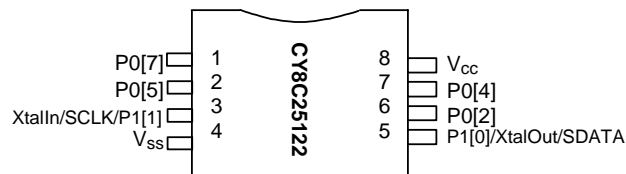

Figure 2: CY8C25122

Table 3: Pin-out 20 Pin

Name	I/O	Pin	Description
P0[7]	I/O	1	Port 0[7] (Analog Input)
P0[5]	I/O	2	Port 0[5] (Analog Input/Output)
P0[3]	I/O	3	Port 0[3] (Analog Input/Output)
P0[1]	I/O	4	Port 0[1] (Analog Input)
SMP	O	5	Switch Mode Pump
P1[7]	I/O	6	Port 1[7]
P1[5]	I/O	7	Port 1[5]
P1[3]	I/O	8	Port 1[3]
P1[1]	I/O	9	Port 1[1] / XtalIn / SCLK
Vss	Power	10	Ground
P1[0]	I/O	11	Port 1[0] / XtalOut / SDATA
P1[2]	I/O	12	Port 1[2]
P1[4]	I/O	13	Port 1[4]
P1[6]	I/O	14	Port 1[6]
XRES	I	15	External Reset
P0[0]	I/O	16	Port 0[0] (Analog Input)
P0[2]	I/O	17	Port 0[2] (Analog Input/Output)
P0[4]	I/O	18	Port 0[4] (Analog Input/Output)
P0[6]	I/O	19	Port 0[6] (Analog Input)
Vcc	Power	20	Supply Voltage

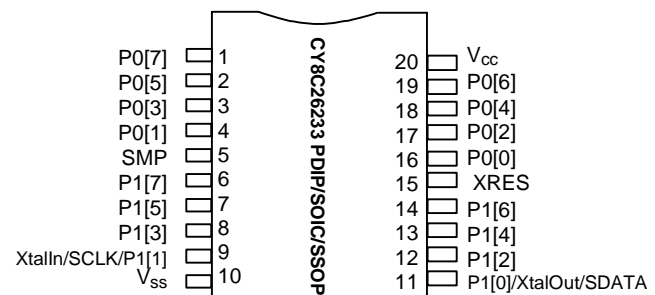

Figure 3: CY8C26233

Table 4: Pin-out 28 Pin

Name	I/O	Pin	Description
P0[7]	I/O	1	Port 0[7] (Analog Input)
P0[5]	I/O	2	Port 0[5] (Analog Input/ Output)
P0[3]	I/O	3	Port 0[3] (Analog Input/ Output)
P0[1]	I/O	4	Port 0[1] (Analog Input)
P2[7]	I/O	5	Port 2[7]
P2[5]	I/O	6	Port 2[5]
P2[3]	I/O	7	Port 2[3] (Non-Multiplexed Analog Input)
P2[1]	I/O	8	Port 2[1] (Non-Multiplexed Analog Input)
SMP	O	9	Switch Mode Pump
P1[7]	I/O	10	Port 1[7]
P1[5]	I/O	11	Port 1[5]
P1[3]	I/O	12	Port 1[3]
P1[1]	I/O	13	Port 1[1] / XtalIn / SCLK
Vss	Power	14	Ground
P1[0]	I/O	15	Port 1[0] / XtalOut / SDATA
P1[2]	I/O	16	Port 1[2]
P1[4]	I/O	17	Port 1[4]
P1[6]	I/O	18	Port 1[6]
XRES	I	19	External Reset
P2[0]	I/O	20	Port 2[0] (Non-Multiplexed Analog Input)
P2[2]	I/O	21	Port 2[2] (Non-Multiplexed Analog Input)
P2[4]	I/O	22	Port 2[4] / External AGNDIn
P2[6]	I/O	23	Port 2[6] / External VREFIn
P0[0]	I/O	24	Port 0[0] (Analog Input)
P0[2]	I/O	25	Port 0[2] (Analog Input/Output)
P0[4]	I/O	26	Port 0[4] (Analog Input/Output)
P0[6]	I/O	27	Port 0[6] (Analog Input)
Vcc	Power	28	Supply Voltage

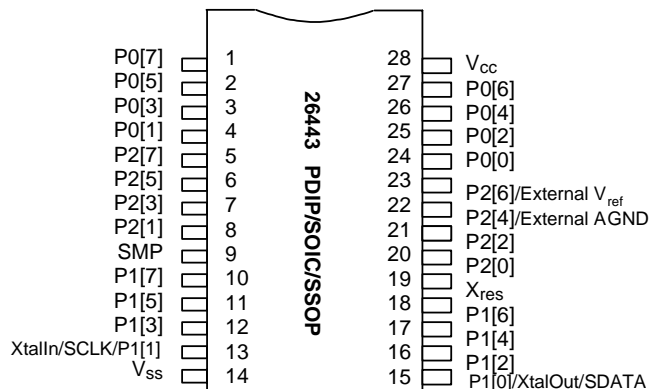

Figure 4: 26443 PDIP/SOIC/SSOP

Table 5: Pin-out 44 Pin

Name	I/O	Pin	Description
P2[5]	I/O	1	Port 2[5]
P2[3]	I/O	2	Port 2[3] (Non-Multiplexed Analog Input)
P2[1]	I/O	3	Port 2[1] (Non-Multiplexed Analog Input)
P3[7]	I/O	4	Port 3[7]
P3[5]	I/O	5	Port 3[5]
P3[3]	I/O	6	Port 3[3]
P3[1]	I/O	7	Port 3[1]
SMP	O	8	Switch Mode Pump
P4[7]	I/O	9	Port 4[7]
P4[5]	I/O	10	Port 4[5]
P4[3]	I/O	11	Port 4[3]
P4[1]	I/O	12	Port 4[1]
P1[7]	I/O	13	Port 1[7]
P1[5]	I/O	14	Port 1[5]
P1[3]	I/O	15	Port 1[3]
P1[1]	I/O	16	Port 1[1] / XtalIn / SCLK
Vss	Power	17	Ground
P1[0]	I/O	18	Port 1[0] / XtalOut / SDATA
P1[2]	I/O	19	Port 1[2]
P1[4]	I/O	20	Port 1[4]
P1[6]	I/O	21	Port 1[6]
P4[0]	I/O	22	Port 4[0]
P4[2]	I/O	23	Port 4[2]
P4[4]	I/O	24	Port 4[4]

Table 5: Pin-out 44 Pin, continued

P4[6]	I/O	25	Port 4[6]
XRES	I	26	External Reset
P3[0]	I/O	27	Port 3[0]
P3[2]	I/O	28	Port 3[2]
P3[4]	I/O	29	Port 3[4]
P3[6]	I/O	30	Port 3[6]
P2[0]	I/O	31	Port 2[0] (Non-Multiplexed Analog Input)
P2[2]	I/O	32	Port 2[2] (Non-Multiplexed Analog Input)
P2[4]	I/O	33	Port 2[4] / External AGNDIn
P2[6]	I/O	34	Port 2[6] / External VREFIn
P0[0]	I/O	35	Port 0[0] (Analog Input)
P0[2]	I/O	36	Port 0[2] (Analog Input/Output)
P0[4]	I/O	37	Port 0[4] (Analog Input/Output)
P0[6]	I/O	38	Port 0[6] (Analog Input)
Vcc	Power	39	Supply Voltage
P0[7]	I/O	40	Port 0[7] (Analog Input)
P0[5]	I/O	41	Port 0[5] (Analog Input/Output)
P0[3]	I/O	42	Port 0[3] (Analog Input/Output)
P0[1]	I/O	43	Port 0[1] (Analog Input)
P2[7]	I/O	44	Port 2[7]

Table 6: Pin-out 48 Pin

Name	I/O	Pin	Description
P0[7]	I/O	1	Port 0[7] (Analog Input)
P0[5]	I/O	2	Port 0[5] (Analog Input/Output)
P0[3]	I/O	3	Port 0[3] (Analog Input/Output)
P0[1]	I/O	4	Port 0[1] (Analog Input)
P2[7]	I/O	5	Port 2[7]
P2[5]	I/O	6	Port 2[5]
P2[3]	I/O	7	Port 2[3] (Non-Multiplexed Analog Input)
P2[1]	I/O	8	Port 2[1] (Non-Multiplexed Analog Input)
P3[7]	I/O	9	Port 3[7]
P3[5]	I/O	10	Port 3[5]
P3[3]	I/O	11	Port 3[3]
P3[1]	I/O	12	Port 3[1]
SMP	O	13	Switch Mode Pump
P4[7]	I/O	14	Port 4[7]
P4[5]	I/O	15	Port 4[5]
P4[3]	I/O	16	Port 4[3]
P4[1]	I/O	17	Port 4[1]
P5[3]	I/O	18	Port 5[3]
P5[1]	I/O	19	Port 5[1]
P1[7]	I/O	20	Port 1[7]
P1[5]	I/O	21	Port 1[5]
P1[3]	I/O	22	Port 1[3]
P1[1]	I/O	23	Port 1[1] / XtalIn / SCLK
Vss	Power	24	Ground
P1[0]	I/O	25	Port 1[0] / XtalOut / SDATA
P1[2]	I/O	26	Port 1[2]
P1[4]	I/O	27	Port 1[4]
P1[6]	I/O	28	Port 1[6]

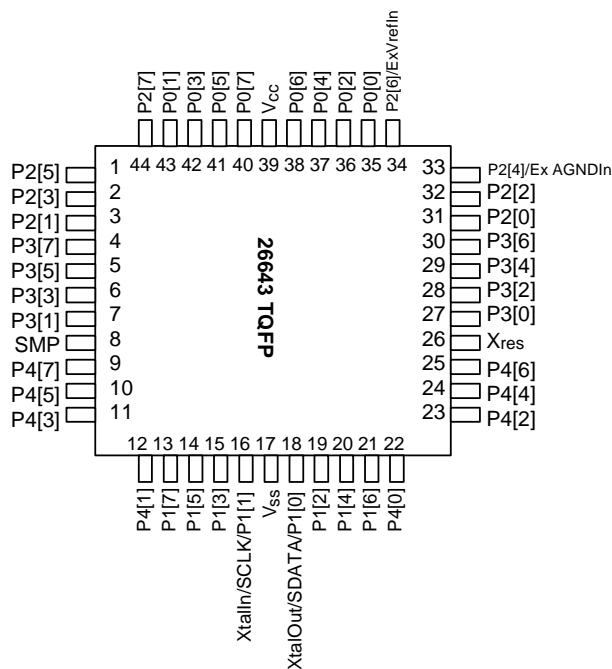

Figure 5: 26643 TQFP

Table 6: Pin-out 48 Pin, continued

P5[0]	I/O	29	Port 5[0]
P5[2]	I/O	30	Port 5[2]
P4[0]	I/O	31	Port 4[0]
P4[2]	I/O	32	Port 4[2]
P4[4]	I/O	33	Port 4[4]
P4[6]	I/O	34	Port 4[6]
XRES	I	35	External Reset
P3[0]	I/O	36	Port 3[0]
P3[2]	I/O	37	Port 3[2]
P3[4]	I/O	38	Port 3[4]
P3[6]	I/O	39	Port 3[6]
P2[0]	I/O	40	Port 2[0] (Non-Multiplexed Analog Input)
P2[2]	I/O	41	Port 2[2] (Non-Multiplexed Analog Input)
P2[4]	I/O	42	Port 2[4] / External AGNDIn
P2[6]	I/O	43	Port 2[6] / External VREFIn
P0[0]	I/O	44	Port 0[0] (Analog Input)
P0[2]	I/O	45	Port 0[2] (Analog Input/Output)
P0[4]	I/O	46	Port 0[4] (Analog Input/Output)
P0[6]	I/O	47	Port 0[6] (Analog Input)
Vcc	Power	48	Supply Voltage

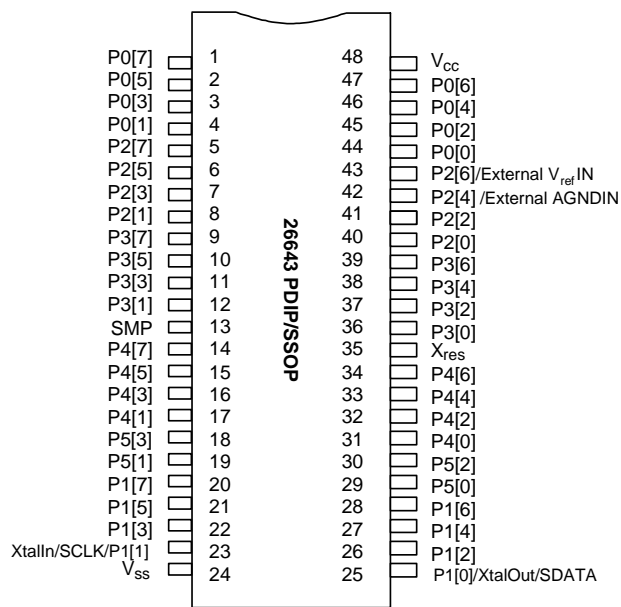

Figure 6: 26643 PDIP/SSOP

2.0 CPU Architecture

2.1 Introduction

This family of microcontrollers is based on a high performance, 8-bit, Harvard architecture microprocessor. Five registers control the primary operation of the CPU core. These registers are affected by various instructions, but are not directly accessible through the register space by the user. For more details on addressing with the register space, see section 4.0.

Table 7: CPU Registers and Mnemonics

Register	Mnemonic
Flags	CPU_F
Program Counter	CPU_PC
Accumulator	CPU_A
Stack Pointer	CPU_SP
Index	CPU_X

The 16 bit Program Counter Register (CPU_PC) allows for direct addressing of the full 16 Kbytes of program memory space available in the largest members of this family. This forms one contiguous program space, and no paging is required.

The Accumulator Register (CPU_A) is the general-purpose register that holds the results of instructions that specify any of the source addressing modes.

The Index Register (CPU_X) holds an offset value that is used in the indexed addressing modes. Typically, this is used to address a block of data within the data memory space.

The Stack Pointer Register (CPU_SP) holds the address of the current top-of-stack in the data memory space. It is affected by the PUSH, POP, LCALL, CALL, RETI, and

RET instructions, which manage the software stack. It can also be affected by the SWAP and ADD instructions.

The Flag Register (CPU_F) has three status bits: Zero Flag bit [1]; Carry Flag bit [2]; Supervisory State bit [3]. The Global Interrupt Enable bit [0] is used to globally enable or disable interrupts. An extended I/O space address, bit [4], is used to determine which bank of the register space is in use. The user cannot manipulate the Supervisory State status bit [3]. The flags are affected by arithmetic, logic, and shift operations. The manner in which each flag is changed is dependent upon the instruction being executed (i.e., AND, OR, XOR... See [Table 23 on page 25](#)).

2.2 CPU Registers

2.2.1 Flags Register

The Flags Register can only be set or reset with logical instruction.

Table 8: Flags Register

Bit #	7	6	5	4	3	2	1	0
POR	0	0	0	0	0	0	1	0
Read/Write	--	--	--	RW	R	RW	RW	RW
Bit Name	Reserved	Reserved	Reserved	XIO	Super	Carry	Zero	Global IE
<p>Bit 7: Reserved Bit 6: Reserved Bit 5: Reserved</p> <p>Bit 4: XIO Set by the user to select between the register banks 0 = Bank 0 1 = Bank 1</p> <p>Bit 3: Super Indicates whether the CPU is executing user code or Supervisor Code. (This code cannot be accessed directly by the user and is not displayed in the ICE debugger.) 0 = User Code 1 = Supervisor Code</p> <p>Bit 2: Carry Set by CPU to indicate whether there has been a carry in the previous logical/arithmetic operation 0 = No Carry 1 = Carry</p> <p>Bit 1: Zero Set by CPU to indicate whether there has been a zero result in the previous logical/arithmetic operation 0 = Not Equal to Zero 1 = Equal to Zero</p> <p>Bit 0: Global IE Determines whether all interrupts are enabled or disabled 0 = Disabled 1 = Enabled</p>								

2.2.2 Accumulator Register

Table 9: Accumulator Register (CPU_A)

Bit #	7	6	5	4	3	2	1	0
POR	0	0	0	0	0	0	0	0
Read/Write	System ¹	System ¹	System ¹	System ¹	System ¹	System ¹	System ¹	System ¹
Bit Name	Data [7]	Data [6]	Data [5]	Data [4]	Data [3]	Data [2]	Data [1]	Data [0]
<p>Bit [7:0]: Data [7:0] 8-bit data value holds the result of any logical/arithmetic instruction that uses a source addressing mode</p>								

1. System - not directly accessible by the user

2.2.3 Index Register

Table 10: Index Register (CPU_X)

Bit #	7	6	5	4	3	2	1	0
POR	0	0	0	0	0	0	0	0
Read/Write	System ¹	System ¹	System ¹	System ¹	System ¹	System ¹	System ¹	System ¹
Bit Name	Data [7]	Data [6]	Data [5]	Data [4]	Data [3]	Data [2]	Data [1]	Data [0]
Bit [7:0]: Data [7:0] 8-bit data value holds an index for any instruction that uses an indexed addressing mode								

1. System - not directly accessible by the user

2.2.4 Stack Pointer Register

Table 11: Stack Pointer Register (CPU_SP)

Bit #	7	6	5	4	3	2	1	0
POR	0	0	0	0	0	0	0	0
Read/Write	System ¹	System ¹	System ¹	System ¹	System ¹	System ¹	System ¹	System ¹
Bit Name	Data [7]	Data [6]	Data [5]	Data [4]	Data [3]	Data [2]	Data [1]	Data [0]
Bit [7:0]: Data [7:0] 8-bit data value holds a pointer to the current top-of-stack								

1. System - not directly accessible by the user

2.2.5 Program Counter Register

Table 12: Program Counter Register (CPU_PC)

Bit #	15	14	13	12	11	10	9	8	7	6	5	4	3	2	1	0
POR	0	0	0	0	0	0	0	0	0	0	0	0	0	0	0	0
Read/Write	1	1	1	1	1	1	1	1	1	1	1	1	1	1	1	1
Bit Name	Data [15]	Data [14]	Data [13]	Data [12]	Data [11]	Data [10]	Data [9]	Data [8]	Data [7]	Data [6]	Data [5]	Data [4]	Data [3]	Data [2]	Data [1]	Data [0]
Bit [15:0]: Data [15:0] 16-bit data value is the low-order/high-order byte of the Program Counter																

1. System - not directly accessible by the user

2.3 Addressing Modes

2.3.1 Source Immediate

The result of an instruction using this addressing mode is placed in the A register, the F register, the SP register, or the X register, which is specified as part of the instruction opcode. Operand 1 is an immediate value that serves as a source for the instruction. Arithmetic instructions

require two sources. Instructions using this addressing mode are two bytes in length.

Table 13: Source Immediate

Opcode	Operand 1
Instruction	Immediate Value

Examples:

```

;In this case, the immediate
;value of 7 is added with the
ADD  A,  7  ;Accumulator, and the result
;is placed in the
;Accumulator.

;In this case, the immediate
;value of 8 is moved to the X
MOV  X,  8  ;register.

;In this case, the immediate
;value of 9 is logically
AND  F,  9  ;ANDed with the F register
;and the result is placed in
;the F register.

```

2.3.2 Source Direct

The result of an instruction using this addressing mode is placed in either the A register or the X register, which is specified as part of the instruction opcode. Operand 1 is an address that points to a location in either the RAM memory space or the register space that is the source for the instruction. Arithmetic instructions require two sources, the second source is the A register or X register specified in the opcode. Instructions using this addressing mode are two bytes in length.

Table 14: Source Direct

Opcode	Operand 1
Instruction	Source Address

Examples:

```

;In this case, the
;value in the RAM
;memory location at
;address 7 is added
;with the Accumulator,
;and the result is
;placed in the
;Accumulator.
ADD  A,  [7]

;In this case, the
;value in the register
;space at address 8 is
;moved to the X
;register.
MOV  X,  REG[8]

```

2.3.3 Source Indexed

The result of an instruction using this addressing mode is placed in either the A register or the X register, which is specified as part of the instruction opcode. Operand 1 is

added to the X register forming an address that points to a location in either the RAM memory space or the register space that is the source for the instruction. Arithmetic instructions require two sources, the second source is the A register or X register specified in the opcode. Instructions using this addressing mode are two bytes.

Table 15: Source Indexed

Opcode	Operand 1
Instruction	Source Index

Examples:

```

;In this case, the
;value in the memory
;location at address
;X + 7 is added with
;the Accumulator, and
;the result is placed
;in the Accumulator.
ADD  A,  [X+7]

;In this case, the
;value in the
;register space at
;address X + 8 is
;moved to the X
;register.
MOV  X,  REG[X+8]

```

2.3.4 Destination Direct

The result of an instruction using this addressing mode is placed within either the RAM memory space or the register space. Operand 1 is an address that points to the location of the result. The source for the instruction is either the A register or the X register, which is specified as part of the instruction opcode. Arithmetic instructions require two sources, the second source is the location specified by Operand 1. Instructions using this addressing mode are two bytes in length.

Table 16: Destination Direct

Opcode	Operand 1
Instruction	Destination Address

Examples:

```

;In this case, the
;value in the memory
;location at address
;7 is added with the
;Accumulator, and the
ADD    [7],    A    ;result is placed in
;the memory location
;at address 7. The
;Accumulator is
;unchanged.

;In this case, the
;Accumulator is moved
;to the register
MOV    REG[8], A   ;space location at
;address 8. The
;Accumulator is
;unchanged.

```

2.3.5 Destination Indexed

The result of an instruction using this addressing mode is placed within either the RAM memory space or the register space. Operand 1 is added to the X register forming the address that points to the location of the result. The source for the instruction is the A register. Arithmetic instructions require two sources, the second source is the location specified by Operand 1 added with the X register. Instructions using this addressing mode are two bytes in length.

Table 17: Destination Indexed

Opcode	Operand 1
Instruction	Destination Index

Example:

```

;In this case, the value
;in the memory location
;at address X+7 is added
;with the Accumulator,
ADD    [X+7],  A   ;and the result is placed
;in the memory location
;at address x+7. The
;Accumulator is
;unchanged.

```

2.3.6 Destination Direct Immediate

The result of an instruction using this addressing mode is placed within either the RAM memory space or the register space. Operand 1 is the address of the result. The

source for the instruction is Operand 2, which is an immediate value. Arithmetic instructions require two sources, the second source is the location specified by Operand 1. Instructions using this addressing mode are three bytes in length.

Table 18: Destination Direct Immediate

Opcode	Operand 1	Operand 2
Instruction	Destination Address	Immediate Value

Examples:

```

;In this case, value in
;the memory location at
;address 7 is added to
ADD    [7],    5   ;the immediate value of
;5, and the result is
;placed in the memory
;location at address 7.

;In this case, the
;immediate value of 6 is
MOV    REG[8], 6   ;moved into the register
;space location at
;address 8.

```

2.3.7 Destination Indexed Immediate

The result of an instruction using this addressing mode is placed within either the RAM memory space or the register space. Operand 1 is added to the X register to form the address of the result. The source for the instruction is Operand 2, which is an immediate value. Arithmetic instructions require two sources, the second source is the location specified by Operand 1 added with the X register. Instructions using this addressing mode are three bytes in length.

Table 19: Destination Indexed Immediate

Opcode	Operand 1	Operand 2
Instruction	Destination Index	Immediate Value

Examples:

```

;In this case, the
;value in the memory
;location at address
;X+7 is added with
;the immediate value
;of 5, and the result
;is placed in the
;memory location at
;address X+7.
ADD  [X+7], 5

;In this case, the
;immediate value of 6
;is moved into the
;location in the
;register space at
;address X+8.
MOV  REG[X+8], 6

```

2.3.8 Destination Direct Direct

The result of an instruction using this addressing mode is placed within the RAM memory. Operand 1 is the address of the result. Operand 2 is an address that points to a location in the RAM memory that is the source for the instruction. This addressing mode is only valid on the MOV instruction. The instruction using this addressing mode is three bytes in length.

Table 20: Destination Direct Direct

Opcode	Operand 1	Operand 2
Instruction	Destination Address	Source Address

Example:

```

;In this case, the value
;in the memory location at
;address 8 is moved to the
;memory location at
;address 7.
MOV  [7], [8]

```

2.3.9 Source Indirect Post Increment

The result of an instruction using this addressing mode is placed in the Accumulator. Operand 1 is an address pointing to a location within the memory space, which contains an address (the indirect address) for the source of the instruction. The indirect address is incremented as part of the instruction execution. This addressing mode is only valid on the MVI instruction. The instruction using this addressing mode is two bytes in length. See **Section 7. Instruction Set** in *PSoC Designer: Assembly*

Language User Guide for further details on MVI instruction.

Table 21: Source Indirect Post Increment

Opcode	Operand 1
Instruction	Source Address Address

Example:

```

;In this case, the value
;in the memory location at
;address 8 is an indirect
;address. The memory
;location pointed to by
;the indirect address is
;moved into the
;Accumulator. The
;indirect address is then
;incremented.
MVI  A, [8]

```

2.3.10 Destination Indirect Post Increment

The result of an instruction using this addressing mode is placed within the memory space. Operand 1 is an address pointing to a location within the memory space, which contains an address (the indirect address) for the destination of the instruction. The indirect address is incremented as part of the instruction execution. The source for the instruction is the Accumulator. This addressing mode is only valid on the MVI instruction. The instruction using this addressing mode is two bytes in length.

Table 22: Destination Indirect Post Increment

Opcode	Operand 1
Instruction	Destination Address Address

Example:

```

;In this case, the
;value in the memory
;location at address 8
;is an indirect
;address. The
;Accumulator is moved
;into the memory
;location pointed to by
;the indirect address.
;The indirect address
;is then incremented.
MVI  [8], A

```

2.4 Instruction Set Summary

Table 23: Instruction Set Summary (Sorted by Mnemonic)

Opcode Hex	Cycles	Bytes	Instruction Format	Flags	Opcode Hex	Cycles	Bytes	Instruction Format	Flags	Opcode Hex	Cycles	Bytes	Instruction Format	Flags
09	4	2	ADC A, expr	C, Z	76	7	2	INC [expr]	C, Z	20	5	1	POP X	
0A	6	2	ADC A, [expr]	C, Z	77	8	2	INC [X+expr]	C, Z	18	5	1	POP A	Z
0B	7	2	ADC A, [X+expr]	C, Z	Fx	13	2	INDEX	Z	10	4	1	PUSH X	
0C	7	2	ADC [expr], A	C, Z	Ex	7	2	JACC		08	4	1	PUSH A	
0D	8	2	ADC [X+expr], A	C, Z	Cx	5	2	JC		7E	10	1	RETI	C, Z
0E	9	3	ADC [expr], expr	C, Z	8x	5	2	JMP		7F	8	1	RET	
0F	10	3	ADC [X+expr], expr	C, Z	Dx	5	2	JNC		6A	4	1	RLC A	C, Z
01	4	2	ADD A, expr	C, Z	Bx	5	2	JNZ		6B	7	2	RLC [expr]	C, Z
02	6	2	ADD A, [expr]	C, Z	Ax	5	2	JZ		6C	8	2	RLC [X+expr]	C, Z
03	7	2	ADD A, [X+expr]	C, Z	7C	13	3	LCALL		28	11	1	ROMX	Z
04	7	2	ADD [expr], A	C, Z	7D	7	3	LJMP		6D	4	1	RRC A	C, Z
05	8	2	ADD [X+expr], A	C, Z	4F	4	1	MOV X, SP		6E	7	2	RRC [expr]	C, Z
06	9	3	ADD [expr], expr	C, Z	50	4	2	MOV A, expr	Z	6F	8	2	RRC [X+expr]	C, Z
07	10	3	ADD [X+expr], expr	C, Z	51	5	2	MOV A, [expr]	Z	19	4	2	SBB A, expr	C, Z
38	5	2	ADD SP, expr		52	6	2	MOV A, [X+expr]	Z	1A	6	2	SBB A, [expr]	C, Z
21	4	2	AND A, expr	Z	53	5	2	MOV [expr], A		1B	7	2	SBB A, [X+expr]	C, Z
22	6	2	AND A, [expr]	Z	54	6	2	MOV [X+expr], A		1C	7	2	SBB [expr], A	C, Z
23	7	2	AND A, [X+expr]	Z	55	8	3	MOV [expr], expr		1D	8	2	SBB [X+expr], A	C, Z
24	7	2	AND [expr], A	Z	56	9	3	MOV [X+expr], expr		1E	9	3	SBB [expr], expr	C, Z
25	8	2	AND [X+expr], A	Z	57	4	2	MOV X, expr		1F	10	3	SBB [X+expr], expr	C, Z
26	9	3	AND [expr], expr	Z	58	6	2	MOV X, [expr]		00	15	1	SSC	
27	10	3	AND [X+expr], expr	Z	59	7	2	MOV X, [X+expr]		11	4	2	SUB A, expr	C, Z
70	4	2	AND F, expr	C, Z	5A	5	2	MOV [expr], X		12	6	2	SUB A, [expr]	C, Z
41	9	3	AND reg[expr], expr	Z	5B	4	1	MOV A, X	Z	13	7	2	SUB A, [X+expr]	C, Z
42	10	3	AND reg[X+expr], expr	Z	5C	4	1	MOV X, A		14	7	2	SUB [expr], A	C, Z
64	4	1	ASL A	C, Z	5D	6	2	MOV A, reg[expr]	Z	15	8	2	SUB [X+expr], A	C, Z
65	7	2	ASL [expr]	C, Z	5E	7	2	MOV A, reg[X+expr]	Z	16	9	3	SUB [expr], expr	C, Z
66	8	2	ASL [X+expr]	C, Z	5F	10	3	MOV [expr], [expr]		17	10	3	SUB [X+expr], expr	C, Z
67	4	1	ASR A	C, Z	60	5	2	MOV reg[expr], A		4B	5	1	SWAP A, X	Z
68	7	2	ASR [expr]	C, Z	61	6	2	MOV reg[X+expr], A		4C	7	2	SWAP A, [expr]	Z
69	8	2	ASR [X+expr]	C, Z	62	8	3	MOV reg[expr], expr		4D	7	2	SWAP X, [expr]	
9x	11	2	CALL		63	9	3	MOV reg[X+expr], expr		4E	5	1	SWAP A, SP	Z
39	5	2	CMP A, expr	if (A=B) Z=1	3E	10	2	MVI A, [[expr]++]	Z	47	8	3	TST [expr], expr	Z
3A	7	2	CMP A, [expr]	if (A<B) C=1	3F	10	2	MVI [[expr]++], A		48	9	3	TST [X+expr], expr	Z
3B	8	2	CMP A, [X+expr]		40	4	1	NOP		49	9	3	TST reg[expr], expr	Z
3C	8	3	CMP [expr], expr		29	4	2	OR A, expr	Z	4A	10	3	TST reg[X+expr], expr	Z
3D	9	3	CMP [X+expr], expr		2A	6	2	OR A, [expr]	Z	72	4	2	XOR F, expr	C, Z
73	4	1	CPL A	Z	2B	7	2	OR A, [X+expr]	Z	31	4	2	XOR A, expr	Z
78	4	1	DEC A	C, Z	2C	7	2	OR [expr], A	Z	32	6	2	XOR A, [expr]	Z
79	4	1	DEC X	C, Z	2D	8	2	OR [X+expr], A	Z	33	7	2	XOR A, [X+expr]	Z
7A	7	2	DEC [expr]	C, Z	2E	9	3	OR [expr], expr	Z	34	7	2	XOR [expr], A	Z
7B	8	2	DEC [X+expr]	C, Z	2F	10	3	OR [X+expr], expr	Z	35	8	2	XOR [X+expr], A	Z
30	9	1	HALT		43	9	3	OR reg[expr], expr	Z	36	9	3	XOR [expr], expr	Z
74	4	1	INC A	C, Z	44	10	3	OR reg[X+expr], expr	Z	37	10	3	XOR [X+expr], expr	Z
75	4	1	INC X	C, Z	71	4	2	OR F, expr	C, Z	45	9	3	XOR reg[expr], expr	Z
										46	10	3	XOR reg[X+expr], expr	Z

Note: Interrupt acknowledge to Interrupt Vector table = 13 cycles.

3.0 Memory Organization

3.1 Flash Program Memory Organization

Table 24: Flash Program Memory Map

Address	Description
0x0000	Reset Vector
0x0004	Supply Monitor Interrupt Vector
0x0008	DBA 00 PSoC Block Interrupt Vector
0x000C	DBA 01 PSoC Block Interrupt Vector
0x0010	DBA 02 PSoC Block Interrupt Vector
0x0014	DBA 03 PSoC Block Interrupt Vector
0x0018	DCA 04 PSoC Block Interrupt Vector
0x001C	DCA 05 PSoC Block Interrupt Vector
0x0020	DCA 06 PSoC Block Interrupt Vector
0x0024	DCA 07 PSoC Block Interrupt Vector
0x0028	Analog Column 0 Interrupt Vector
0x002C	Analog Column 1 Interrupt Vector
0x0030	Analog Column 2 Interrupt Vector
0x0034	Analog Column 3 Interrupt Vector
0x0038	GPIO Interrupt Vector
0x003C	Sleep Timer Interrupt Vector
0x0040	On-Chip User Program Memory Starts Here

0x3FFF	16K Flash Maximum Depending on Version

3.2 RAM Data Memory Organization

The stack on this device grows from low addresses to high addresses. The Linker function within PSoC Designer locates the bottom of the stack after the end of Global Variables. This allows the stack to grow from just after the Global Variables until 0xFF. The stack will wrap back to 0x00 on an overflow condition.

Table 25: RAM Data Memory Map

Address	Description
0x00	First General Purpose RAM Location
0xXX	General Purpose RAM
0xXY	General Purpose RAM
0xXZ	Last General Purpose RAM Location
0xYX	Bottom of Hardware Stack
0xYY	↓ Stack Grows This Way ↓
0xFF	Top of Hardware Stack

4.0 Register Organization

4.1 Introduction

There are two register banks implemented on these devices. Each bank contains 256 addresses. The purpose of these register banks is to personalize and parameterize the on-chip resources as well as read and write data values.

The user selects between the two banks by setting the XIO bit in the CPU_F Flag Register.

In some cases, the same register is available on either bank, for convenience. These registers (71h to 9fh) can be accessed from either bank.

Note: All register addresses not shown are reserved and should never be written. In addition, unused or reserved bits in any register should always be written to 0.

4.2 Register Bank 0 Map

Table 26: Bank 0

Register Name	Address	Data Sheet Page	Access	Register Name	Address	Data Sheet Page	Access	Register Name	Address	Data Sheet Page	Access	Register Name	Address	Data Sheet Page	Access
PRT0DR	00h	31	RW	Reserved	40h			ASA10CR0	80h	88	RW	Reserved	C0h		
PRT0IE	01h	31	W		41h			ASA10CR1	81h	90	RW		C1h		
PRT0GS	02h	32	W		42h			ASA10CR2	82h	92	RW		C2h		
Reserved	03h				43h			ASA10CR3	83h	93	RW		C3h		
PRT1DR	04h	31	RW		44h			ASB11CR0	84h	95	RW		C4h		
PRT1IE	05h	31	W		45h			ASB11CR1	85h	97	RW		C5h		
PRT1GS	06h	32	W		46h			ASB11CR2	86h	99	RW		C6h		
Reserved	07h				47h			ASB11CR3	87h	100	RW		C7h		
PRT2DR	08h	31	RW		48h			ASA12CR0	88h	88	RW		C8h		
PRT2IE	09h	31	W		49h			ASA12CR1	89h	90	RW		C9h		
PRT2GS	0Ah	32	W		4Ah			ASA12CR2	8Ah	92	RW		CAh		
Reserved	0Bh				4Bh			ASA12CR3	8Bh	93	RW		CBh		
PRT3DR	0Ch	31	RW		4Ch			ASB13CR0	8Ch	95	RW		CCh		
PRT3IE	0Dh	31	W		4Dh			ASB13CR1	8Dh	97	RW		CDh		
PRT3GS	0Eh	32	W		4Eh			ASB13CR2	8Eh	99	RW		CEh		
Reserved	0Fh				4Fh			ASB13CR3	8Fh	100	RW		CFh		
PRT4DR	10h	31	RW		50h			ASB20CR0	90h	95	RW		D0h		
PRT4IE	11h	31	W		51h			ASB20CR1	91h	97	RW		D1h		
PRT4GS	12h	32	W		52h			ASB20CR2	92h	99	RW		D2h		
Reserved	13h				53h			ASB20CR3	93h	100	RW		D3h		
PRT5DR	14h	31	RW		54h			ASA21CR0	94h	88	RW		D4h		
PRT5IE	15h	31	W		55h			ASA21CR1	95h	90	RW		D5h		
PRT5GS	16h	32	W		56h			ASA21CR2	96h	92	RW		D6h		
Reserved	17h				57h			ASA21CR3	97h	93	RW		D7h		
	18h			58h			ASB22CR0	98h	95	RW	D8h				
	19h			59h			ASB22CR1	99h	97	RW	D9h				
	1Ah			5Ah			ASB22CR2	9Ah	99	RW	DAh				
	1Bh			5Bh			ASB22CR3	9Bh	100	RW	DBh				
	1Ch			5Ch			ASA23CR0	9Ch	88	RW	DCh				
	1Dh			5Dh			ASA23CR1	9Dh	90	RW	DDh				
Reserved	1Eh			5Eh			ASA23CR2	9Eh	92	RW	DEh				
	1Fh			5Fh			ASA23CR3	9Fh	93	RW	DFh				
	DBA00DR0	20h	54	1	AMX_IN	60h	104	RW	Reserved	A0h		INT_MSK0	E0h	45	RW
	DBA00DR1	21h	54	1	Reserved	61h				A1h		INT_MSK1	E1h	46	RW
	DBA00DR2	22h	54	1		62h				A2h		INT_VC	E2h	46	RW
	DBA00CR0	23h	55	1	ARF_CR	63h	73	RW		A3h		RES_WDT	E3h	116	RW
	DBA01DR0	24h	54	1	CMP_CR	64h	101	1		A4h		DEC_DH/DEC_CL	E4h	113	RW
DBA01DR1	25h	54	1	ASY_CR	65h	102	1	A5h			DEC_DL	E5h	113	R	
DBA01DR2	26h	54	1		66h			A6h			DEC_CR	E6h	113	RW	
DBA01CR0	27h	55	1	Reserved	67h			A7h			Reserved	E7h			
DBA02DR0	28h	54	1		68h			A8h			MUL_X	E8h	110	W	
DBA02DR1	29h	54	1		69h			A9h			MUL_Y	E9h	110	W	
DBA02DR2	2Ah	54	1		6Ah			AAh			MUL_DH	EAh	111	R	
DBA02CR0	2Bh	55	1		6Bh			ABh			MUL_DL	EBh	111	R	
DBA03DR0	2Ch	54	1		6Ch			ACh			ACC_DR1/MAC_X	ECh	111	RW	
DBA03DR1	2Dh	54	1		6Dh			ADh			ACC_DR0/MAC_Y	EDh	111	RW	
DBA03DR2	2Eh	54	1		6Eh			AEnh			ACC_DR3/MAC_CL0	EEh	112	RW	
DBA03CR0	2Fh	55	1		6Fh			AFh			ACC_DR2/MAC_CL1	EFh	112	RW	
DCA04DR0	30h	54	1		70h			B0h			Reserved	F0h			
DCA04DR1	31h	54	1	ACA00CR0	71h	82	RW	B1h				F1h			
DCA04DR2	32h	54	1	ACA00CR1	72h	83	RW	B2h				F2h			
DCA04CR0	33h	55	1	ACA00CR2	73h	84	RW	B3h				F3h			
DCA05DR0	34h	54	1	Reserved	74h			B4h				F4h			
DCA05DR1	35h	54	1	ACA01CR0	75h	82	RW	B5h				F5h			
DCA05DR2	36h	54	1	ACA01CR1	76h	83	RW	B6h				F6h			
DCA05CR0	37h	55	1	ACA01CR2	77h	84	RW	B7h				F7h			
DCA06DR0	38h	54	1	Reserved	78h			B8h		F8h					
DCA06DR1	39h	54	1	ACA02CR0	79h	82	RW	B9h		F9h					
DCA06DR2	3Ah	54	1	ACA02CR1	7Ah	83	RW	BAh		FAh					
DCA06CR0	3Bh	55	1	ACA02CR2	7Bh	84	RW	BBh		FBh					
DCA07DR0	3Ch	54	1	Reserved	7Ch			BCh		FCh					
DCA07DR1	3Dh	54	1	ACA03CR0	7Dh	82	RW	BDh		FDh					
DCA07DR2	3Eh	54	1	ACA03CR1	7Eh	83	RW	BEh		FEh					
DCA07CR0	3Fh	55	1	ACA03CR2	7Fh	84	RW	BFh		CPU_SCR		FFh	114	1	

4.3 Register Bank 1 Map

Table 27: Bank 1

Register Name	Address	Data Sheet Page	Access	Register Name	Address	Data Sheet Page	Access	Register Name	Address	Data Sheet Page	Access	Register Name	Address	Data Sheet Page	Access	
PRT0DM0	00h	32	W	Reserved	40h			ASA10CR0	80h	88	RW	Reserved	C0h			
PRT0DM1	01h	33	W		41h			ASA10CR1	81h	90	RW		C1h			
PRT0IC0	02h	33	W		42h			ASA10CR2	82h	92	RW		C2h			
PRT0IC1	03h	34	W		43h			ASA10CR3	83h	93	RW		C3h			
PRT1DM0	04h	32	W		44h			ASB11CR0	84h	95	RW		C4h			
PRT1DM1	05h	33	W		45h			ASB11CR1	85h	97	RW		C5h			
PRT1IC0	06h	33	W		46h			ASB11CR2	86h	99	RW		C6h			
PRT1IC1	07h	34	W		47h			ASB11CR3	87h	100	RW		C7h			
PRT2DM0	08h	32	W		48h			ASA12CR0	88h	88	RW		C8h			
PRT2DM1	09h	33	W		49h			ASA12CR1	89h	90	RW		C9h			
PRT2IC0	0Ah	33	W		4Ah			ASA12CR2	8Ah	92	RW		CAh			
PRT2IC1	0Bh	34	W		4Bh			ASA12CR3	8Bh	93	RW		CBh			
PRT3DM0	0Ch	32	W		4Ch			ASB13CR0	8Ch	95	RW		CCh			
PRT3DM1	0Dh	33	W		4Dh			ASB13CR1	8Dh	97	RW		CDh			
PRT3IC0	0Eh	33	W		4Eh			ASB13CR2	8Eh	99	RW		CEh			
PRT3IC1	0Fh	34	W		4Fh			ASB13CR3	8Fh	100	RW		CFh			
PRT4DM0	10h	32	W		50h			ASB20CR0	90h	95	RW		D0h			
PRT4DM1	11h	33	W		51h			ASB20CR1	91h	97	RW		D1h			
PRT4IC0	12h	33	W		52h			ASB20CR2	92h	99	RW		D2h			
PRT4IC1	13h	34	W		53h			ASB20CR3	93h	100	RW		D3h			
PRT5DM0	14h	32	W	54h			ASA21CR0	94h	88	RW	D4h					
PRT5DM1	15h	33	W	55h			ASA21CR1	95h	90	RW	D5h					
PRT5IC0	16h	33	W	56h			ASA21CR2	96h	92	RW	D6h					
PRT5IC1	17h	34	W	57h			ASA21CR3	97h	93	RW	D7h					
Reserved	18h			58h			ASB22CR0	98h	95	RW	D8h					
	19h			59h			ASB22CR1	99h	97	RW	D9h					
	1Ah			5Ah			ASB22CR2	9Ah	99	RW	DAh					
	1Bh			5Bh			ASB22CR3	9Bh	100	RW	DBh					
	1Ch			5Ch			ASA23CR0	9Ch	88	RW	DCh					
	1Dh			5Dh			ASA23CR1	9Dh	90	RW	DDh					
	1Eh			5Eh			ASA23CR2	9Eh	92	RW	DEh					
1Fh			5Fh			ASA23CR3	9Fh	93	RW	DFh						
DBA00FN	20h	50	RW	CLK_CR0	60h	76	RW	Reserved	OSC_CR0	A0h		OSC_CR0	E0h	40	RW	
DBA00IN	21h	51	RW	CLK_CR1	61h	77	RW		OSC_CR1	A1h			OSC_CR1	E1h	40	RW
DBA00OU	22h	53	RW	ABF_CR	62h	106	W		Reserved	A2h			Reserved	E2h		
Reserved	23h			AMD_CR	63h	107	RW		VLT_CR	A3h			VLT_CR	E3h	118	RW
DBA01FN	24h	50	RW	Reserved	64h				Reserved	A4h			Reserved	E4h		
DBA01IN	25h	51	RW		65h				Reserved	A5h			Reserved	E5h		
DBA01OU	26h	53	RW		66h				Reserved	A6h			Reserved	E6h		
Reserved	27h				67h				Reserved	A7h			Reserved	E7h		
DBA02FN	28h	50	RW		68h				IMO_TR	A8h			IMO_TR	E8h	35	W
DBA02IN	29h	51	RW		69h				ILO_TR	A9h			ILO_TR	E9h	36	W
DBA02OU	2Ah	53	RW		6Ah				BDG_TR	AAh			BDG_TR	EAh	120	W
Reserved	2Bh				6Bh				ECO_TR	ABh			ECO_TR	EBh	37	W
DBA03FN	2Ch	50	RW		6Ch				Reserved	ACH			Reserved	ECh		
DBA03IN	2Dh	51	RW		6Dh				Reserved	ADh			Reserved	EDh		
DBA03OU	2Eh	53	RW	6Eh			Reserved		Aeh			Reserved	Eeh			
Reserved	2Fh			6Fh			Reserved		Afh			Reserved	Efh			
DCA04FN	30h	50	RW	70h			Reserved		B0h			Reserved	F0h			
DCA04IN	31h	51	RW	ACA00CR0	71h	82	RW		Reserved	B1h			Reserved	F1h		
DCA04OU	32h	53	RW	ACA00CR1	72h	83	RW		Reserved	B2h			Reserved	F2h		
Reserved	33h			ACA00CR2	73h	84	RW		Reserved	B3h			Reserved	F3h		
DCA05FN	34h	50	RW	Reserved	74h			Reserved	B4h			Reserved	F4h			
DCA05IN	35h	51	RW	ACA01CR0	75h	82	RW	Reserved	B5h			Reserved	F5h			
DCA05OU	36h	53	RW	ACA01CR1	76h	83	RW	Reserved	B6h			Reserved	F6h			
Reserved	37h			ACA01CR2	77h	84	RW	Reserved	B7h			Reserved	F7h			
DCA06FN	38h	50	RW	Reserved	78h			Reserved	B8h			Reserved	F8h			
DCA06IN	39h	51	RW	ACA02CR0	79h	82	RW	Reserved	B9h			Reserved	F9h			
DCA06OU	3Ah	53	RW	ACA02CR1	7Ah	83	RW	Reserved	BAh			Reserved	FAh			
Reserved	3Bh			ACA02CR2	7Bh	84	RW	Reserved	BBh			Reserved	FBh			
DCA07FN	3Ch	50	RW	Reserved	7Ch			Reserved	BCh			Reserved	FCh			
DCA07IN	3Dh	51	RW	ACA03CR0	7Dh	82	RW	Reserved	BDh			Reserved	FDh			
DCA07OU	3Eh	53	RW	ACA03CR1	7Eh	83	RW	Reserved	BEh			Reserved	FEh			
Reserved	3Fh			ACA03CR2	7Fh	84	RW	Reserved	BFh			CPU_SCR	FFh	114	¹	

1. Read/Write access is bit-specific or varies by function. See register.

5.0 I/O Ports

5.1 Introduction

Up to five 8-bit-wide I/O ports (P0-P4) and one 4-bit wide I/O port (P5) are implemented. The number of general purpose I/Os implemented and connected to pins depends on the individual part chosen. All port bits are independently programmable and have the following capabilities:

- General-purpose digital input readable by the CPU.
- General-purpose digital output writable by the CPU.
- Independent control of data direction for each port bit.
- Independent access for each port bit to Global Input and Global Output busses.
- Interrupt programmable to assert on rising edge, falling edge, or change from last pin state read.
- Output drive strength programmable in logic 0 and 1 states as strong, resistive (pull-up or pull-down), or high impedance.
- A slew rate controlled output mode is available.
- In high impedance, the digital input can be disabled to lower power consumption.

Port 1, Pin 0 is used in conjunction with device Test Mode and does not behave the same as other I/O ports immediately after reset. A device reset with Power On Reset (POR) will drive P1[0] high for 8 ms immediately after POR is released because there is a CPU hold-off time of approximately 64 ms before code execution begins. It will then drive P1[0] low for 8 ms. This can impact external circuits connected to Port 1, Pin 0.

In System Sleep State, GPIO Pins P2[4] and P2[6] should be held to a logic low or a false Low Voltage Detect interrupt may be triggered. The cause is in the System Sleep State, the internal Bandgap reference generator is turned off and the reference voltage is maintained on a capacitor.

The circumstances are that during sleep, the reference voltage on the capacitor is refreshed periodically at the sleep system duty cycle. Between refresh cycles, this voltage may leak slightly to either the positive supply or ground. If pins P2[4] or P2[6] are in a high state, the leakage to the positive supply is accelerated (especially at high temperature). Since the reference voltage is compared to the supply to detect a low voltage condition, this accelerated leakage to the positive supply voltage will cause that voltage to appear lower than it actually is, leading to the generation of a false Low Voltage Detect interrupt.

Port 0 and Port 2 have additional analog input and/or analog output capability. The specific routing and multiplexing of analog signals is shown in the following diagram:

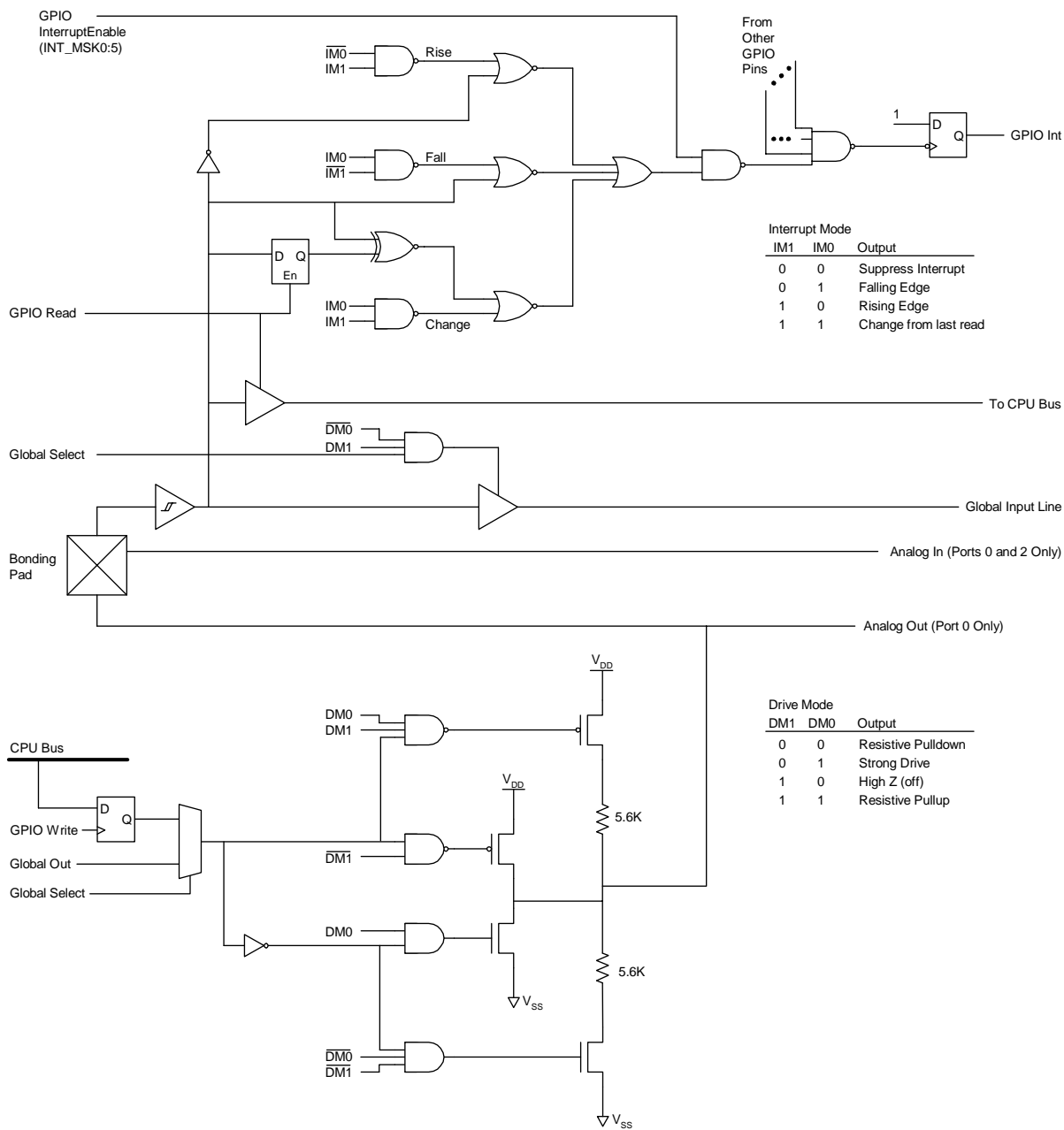

Figure 7: General Purpose I/O Pins

6.0 I/O Registers

6.1 Port Data Registers

Table 28: Port Data Registers

Bit #	7	6	5	4	3	2	1	0
POR	0	0	0	0	0	0	0	0
Read/Write	RW	RW	RW	RW	RW	RW	RW	RW
Bit Name	Data [7]	Data [6]	Data [5]	Data [4]	Data [3]	Data [2]	Data [1]	Data [0]

Bit [7:0]: Data [7:0] When written is the bits for output on port pins. When read is the state of the port pins

Port 0 Data Register (PRT0DR, Address = Bank 0, 00h)

Port 1 Data Register (PRT1DR, Address = Bank 0, 04h)

Port 2 Data Register (PRT2DR, Address = Bank 0, 08h)

Port 3 Data Register (PRT3DR, Address = Bank 0, 0Ch)

Port 4 Data Register (PRT4DR, Address = Bank 0, 10h)

Port 5 Data Register (PRT5DR, Address = Bank 0, 14h) **Note:** Port 5 is 4-bits wide, Bit [3:0]

6.2 Port Interrupt Enable Registers

Table 29: Port Interrupt Enable Registers

Bit #	7	6	5	4	3	2	1	0
POR	0	0	0	0	0	0	0	0
Read/Write	W	W	W	W	W	W	W	W
Bit Name	Int En [7]	Int En [6]	Int En [5]	Int En [4]	Int En [3]	Int En [2]	Int En [1]	Int En [0]

Bit [7:0]: Int En [7:0] When written sets the pin interrupt state
 0 = Interrupt disabled for pin
 1 = Interrupt enabled for pin

Port 0 Interrupt Enable Register (PRT0IE, Address = Bank 0, 01h)

Port 1 Interrupt Enable Register (PRT1IE, Address = Bank 0, 05h)

Port 2 Interrupt Enable Register (PRT2IE, Address = Bank 0, 09h)

Port 3 Interrupt Enable Register (PRT3IE, Address = Bank 0, 0Dh)

Port 4 Interrupt Enable Register (PRT4IE, Address = Bank 0, 11h)

Port 5 Interrupt Enable Register (PRT5IE, Address = Bank 0, 15h) **Note:** Port 5 is 4-bits wide

6.3 Port Global Select Registers

Table 30: Port Global Select Registers

Bit #	7	6	5	4	3	2	1	0
POR	0	0	0	0	0	0	0	0
Read/Write	W	W	W	W	W	W	W	W
Bit Name	GlobSel [7]	GlobSel [6]	GlobSel [5]	GlobSel [4]	GlobSel [3]	GlobSel [2]	GlobSel [1]	GlobSel [0]

Bit [7:0]: Global Select [7:0] When written determines whether a pin is connected to the Global Input Bus and Global Output Bus
0 = Not Connected
1 = Connected

Drive Mode xx = Global Select Register 0 = Standard CPU controlled port (Default)
Drive Mode 1 0 (High Z) = Global Select Register 1 = Direct Drive of associated Global Input line
Drive Mode 0 0, 0 1, 1 1 = Global Select Register 1 = Direct Receive from associated Global Output line

Port 0 Global Select Register (PRT0GS, Address = Bank 0, 02h)

Port 1 Global Select Register (PRT1GS, Address = Bank 0, 06h)

Port 2 Global Select Register (PRT2GS, Address = Bank 0, 0Ah)

Port 3 Global Select Register (PRT3GS, Address = Bank 0, 0Eh)

Port 4 Global Select Register (PRT4GS, Address = Bank 0, 12h)

Port 5 Global Select Register (PRT5GS, Address = Bank 0, 16h) **Note:** If implemented, Port 5 is 4-bits wide

6.3.1 Port Drive Mode 0 Registers

Table 31: Port Drive Mode 0 Registers

Bit #	7	6	5	4	3	2	1	0
POR	0	0	0	0	0	0	0	0
Read/Write	W	W	W	W	W	W	W	W
Bit Name	DM0 [7]	DM0 [6]	DM0 [5]	DM0 [4]	DM0 [3]	DM0 [2]	DM0 [1]	DM0 [0]

Bit [7:0]: DM0 [7:0] The two Drive Mode bits that control a particular port pin are treated as a pair and are decoded as follows:

Port Data Register Bit 0 = Drive Mode 0 0 = 0 Resistive (Default)
Port Data Register Bit 0 = Drive Mode 0 1 = 0 Strong
Port Data Register Bit 0 = Drive Mode 1 0 = High Z
Port Data Register Bit 0 = Drive Mode 1 1 = 0 Strong
Port Data Register Bit 1 = Drive Mode 0 0 = 1 Strong
Port Data Register Bit 1 = Drive Mode 0 1 = 1 Strong
Port Data Register Bit 1 = Drive Mode 1 0 = High Z
Port Data Register Bit 1 = Drive Mode 1 1 = 1 Resistive

Port 0 Drive Mode 0 Register (PRT0DM0, Address = Bank 1, 00h)

Port 1 Drive Mode 0 Register (PRT1DM0, Address = Bank 1, 04h)

Port 2 Drive Mode 0 Register (PRT2DM0, Address = Bank 1, 08h)

Port 3 Drive Mode 0 Register (PRT3DM0, Address = Bank 1, 0Ch)

Port 4 Drive Mode 0 Register (PRT4DM0, Address = Bank 1, 10h)

Port 5 Drive Mode 0 Register (PRT5DM0, Address = Bank 1, 14h) **Note:** Port 5 is 4-bits wide

6.3.2 Port Drive Mode 1 Registers

Table 32: Port Drive Mode 1 Registers

Bit #	7	6	5	4	3	2	1	0
POR	0	0	0	0	0	0	0	0
Read/Write	W	W	W	W	W	W	W	W
Bit Name	DM1 [7]	DM1 [6]	DM1 [5]	DM1 [4]	DM1 [3]	DM1 [2]	DM1 [1]	DM1 [0]

Bit [7:0]: DM1 [7:0] See truth table for Port Drive Mode 0 Registers, above

Port 0 Drive Mode 1 Register (PRT0DM1, Address = Bank 1, 01h)
 Port 1 Drive Mode 1 Register (PRT1DM1, Address = Bank 1, 05h)
 Port 2 Drive Mode 1 Register (PRT2DM1, Address = Bank 1, 09h)
 Port 3 Drive Mode 1 Register (PRT3DM1, Address = Bank 1, 0Dh)
 Port 4 Drive Mode 1 Register (PRT4DM1, Address = Bank 1, 11h)
 Port 5 Drive Mode 1 Register (PRT5DM1, Address = Bank 1, 15h) **Note:** Port 5 is 4-bits wide

6.3.3 Port Interrupt Control 0 Registers

Table 33: Port Interrupt Control 0 Registers

Bit #	7	6	5	4	3	2	1	0
POR	0	0	0	0	0	0	0	0
Read/Write	W	W	W	W	W	W	W	W
Bit Name	IC0 [7]	IC0 [6]	IC0 [5]	IC0 [4]	IC0 [3]	IC0 [2]	IC0 [1]	IC0 [0]

Bit [7:0]: IC0 [7:0] The two Interrupt Control bits that control a particular port pin are treated as a pair and are decoded as follows:
 IC1 [x], IC0 [x] = 0 0 = Disabled (Default)
 IC1 [x], IC0 [x] = 0 1 = Falling Edge (-)
 IC1 [x], IC0 [x] = 1 0 = Rising Edge (+)
 IC1 [x], IC0 [x] = 1 1 = Change from Last Direct Read

Port 0 Interrupt Control 0 Register (PRT0IC0, Address = Bank 1, 02h)
 Port 1 Interrupt Control 0 Register (PRT1IC0, Address = Bank 1, 06h)
 Port 2 Interrupt Control 0 Register (PRT2IC0, Address = Bank 1, 0Ah)
 Port 3 Interrupt Control 0 Register (PRT3IC0, Address = Bank 1, 0Eh)
 Port 4 Interrupt Control 0 Register (PRT4IC0, Address = Bank 1, 12h)
 Port 5 Interrupt Control 0 Register (PRT5IC0, Address = Bank 1, 16h) **Note:** Port 5 is 4-bits wide

6.3.4 Port Interrupt Control 1 Registers

Table 34: Port Interrupt Control 1 Registers

Bit #	7	6	5	4	3	2	1	0
POR	0	0	0	0	0	0	0	0
Read/ Write	W	W	W	W	W	W	W	W
Bit Name	IC1 [7]	IC1 [6]	IC1 [5]	IC1 [4]	IC1 [3]	IC1 [2]	IC1 [1]	IC1 [0]
Bit [7:0]: <u>IC1 [7:0]</u> See truth table for Port Interrupt Control 0 Registers, above								

Port 0 Interrupt Control 1 Register (PRT0IC1, Address = Bank 1, 03h)

Port 1 Interrupt Control 1 Register (PRT1IC1, Address = Bank 1, 07h)

Port 2 Interrupt Control 1 Register (PRT2IC1, Address = Bank 1, 0Bh)

Port 3 Interrupt Control 1 Register (PRT3IC1, Address = Bank 1, 0Fh)

Port 4 Interrupt Control 1 Register (PRT4IC1, Address = Bank 1, 13h)

Port 5 Interrupt Control 1 Register (PRT5IC1, Address = Bank 1, 17h) **Note:** Port 5 is 4-bits wide

7.0 Clocking

7.1 Oscillator Options

7.1.1 Internal Main Oscillator

The internal main oscillator outputs two frequencies, 48 MHz and 24 MHz. In the absence of a high-precision input source from the external oscillator, the accuracy of this circuit is +/- 2.5% (between 0°C and +85°C). No external components are required to achieve this level of accuracy. The Internal Main Oscillator Trim Register (IMO_TR) is used to calibrate this oscillator into specified tolerance. Factory-programmed trim values are available for 5.0V and 3.3V operation. The 5.0V value is loaded in the IMO_TR register upon reset. This register must be adjusted when the operating voltage is outside the range

for which factory calibration was set. The factory-programmed trim value is selected using the Table Read Supervisor Call, and is documented in 11.8.

There is an option to phase lock this oscillator to the External Crystal Oscillator. The choice of crystal and its inherent accuracy will determine the overall accuracy of the oscillator. The External Crystal Oscillator must be stable prior to locking the frequency of the Internal Main Oscillator to this reference source.

Table 35: Internal Main Oscillator Trim Register

Bit #	7	6	5	4	3	2	1	0
POR	FS ¹	FS ¹	FS ¹	FS ¹	FS ¹	FS ¹	FS ¹	FS ¹
Read/Write	W	W	W	W	W	W	W	W
Bit Name	IMO Trim [7]	IMO Trim [6]	IMO Trim [5]	IMO Trim [4]	IMO Trim [3]	IMO Trim [2]	IMO Trim [1]	IMO Trim [0]

Bit [7:0]: IMO Trim [7:0] Data value stored will alter the trimmed frequency of the Internal Main Oscillator. A larger value in this register will increase the speed of the Internal Main Oscillator

1. FS = Factory set trim value

Internal Main Oscillator Trim Register (IMO_TR, Address = Bank 1, E8h)

7.1.2 Internal Low Speed Oscillator

An internal low speed oscillator of nominally 32 kHz is available to generate sleep wake-up interrupts and Watchdog resets if the user does not want to attach a 32.768 kHz watch crystal. This oscillator can also be used as a clocking source for the digital PSoC blocks.

The oscillator operates in two different modes. A trim value is written to the Internal Low Speed Oscillator Trim Register (ILO_TR), shown below, upon reset. See section 13.0 for accuracy information. When the IC is put into sleep mode this oscillator drops into an ultra low current state and the accuracy is reduced.

This register sets the adjustment for the Internal Low Speed Oscillator. The value placed in this register is based on factory testing. It is recommended that the user not alter this value.

Table 36: Internal Low Speed Oscillator Trim Register

Bit #	7	6	5	4	3	2	1	0
POR	0	0	FS ¹	FS ¹	FS ¹	FS ¹	FS ¹	FS ¹
Read/Write	--	W	W	W	W	W	W	W
Bit Name	Reserved	Disable	ILO Trim [5]	ILO Trim [4]	ILO Trim [3]	ILO Trim [2]	ILO Trim [1]	ILO Trim [0]

Bit 7: Reserved

Bit 6: Disable
0 = Low Speed Oscillator is on
1 = Low Speed Oscillator is off (minimum power state)

Bit [5:0]: ILO Trim [5:0] Data value stored will alter the trimmed frequency of the Internal Low Speed Oscillator. (Not recommended for customer alteration)

1. FS = Factory set trim value

Internal Low Speed Oscillator Trim Register (ILO_TR, Address = Bank 1, E9h)

7.1.3 External Crystal Oscillator

The XtalIn and XtalOut pins support connection of a 32.768 kHz watch crystal to drive the 32K clock. To connect to the external crystal, the XtalIn and XtalOut pins' drive modes must be set to High Z. To enable the external crystal oscillator, bit 7 of the Oscillator Control 0 Register (OSC_CR0) must be set (default is off). Note that the Internal Low Speed Oscillator continues to run when this external function is selected. It runs until the oscillator is automatically switched over when the sleep timer reaches terminal count. External feedback capacitors to V_{CC} are required.

The firmware steps involved in switching between the Internal Low Speed Oscillator and External Crystal Oscillator are as follows:

1. At reset, the chip begins operation using the Internal Low Speed Oscillator.
2. User immediately selects a sleep interval of 1 second in the Oscillator Control 0 Register (OSC_CR0), as the oscillator stabilization interval.
3. User selects External Crystal Oscillator by setting bit [7] in Oscillator Control 0 Register (OSC_CR0) to 1.
4. The External Crystal Oscillator becomes the selected 32.768 kHz source at the end of the 1-second

interval, created by the Sleep Interrupt logic. The 1-second interval gives the oscillator time to stabilize before it becomes the active source. The Sleep Interrupt need not be enabled for the switch over to occur. The user may want to reset the sleep timer (if this does not interfere with any ongoing real-time clock operation), to guarantee the interval length.

5. The user must wait the 1-second stabilization period prior to engaging the PLL mode to lock the Internal Main Oscillator frequency to the External Crystal Oscillator frequency.

If the proper settings are selected in PSoC Designer, the above steps are automatically done in *boot.asm*.

Note: Transitions between oscillator domains may produce glitches on the 32K clock bus. Functions that require accuracy on the 32K clock should be enabled after the transition in oscillator domains.

The External Crystal Oscillator Trim Register (ECO_TR) sets the adjustment for the External Crystal Oscillator. The value placed in this register at reset is based on factory testing. This register does not adjust the frequency of the External Crystal Oscillator. It is recommended that the user not alter this value.

Table 37: External Crystal Oscillator Trim Register

Bit #	7	6	5	4	3	2	1	0
POR	FS ¹	FS ¹	0	0	FS ¹	FS ¹	FS ¹	FS ¹
Read/Write	W	W	--	--	W	W	W	W
Bit Name	PSSDC [1]	PSSDC [0]	Reserved	Reserved	Amp [1]	Amp [0]	Bias [1]	Bias [0]

Bit [7:6]: PSSDC [1:0] Power System Sleep Duty Cycle. (Not recommended for customer alteration)
 0 0 = 1/128
 0 1 = 1/512
 1 0 = 1/32
 1 1 = 1/8

Bit 5: Reserved
Bit 4: Reserved

Bit [3:2]: Amp [1:0] Sets the amplitude of the adjustment. (Not recommended for customer alteration)

Bit [1:0]: Bias [1:0] Sets the bias of the adjustment. (Not recommended for customer alteration)

1. FS = Factory set trim value

External Crystal Oscillator Trim Register (ECO_TR, Address = Bank 1, EBh)

7.1.4 External Crystal Oscillator Component Connections and Selections

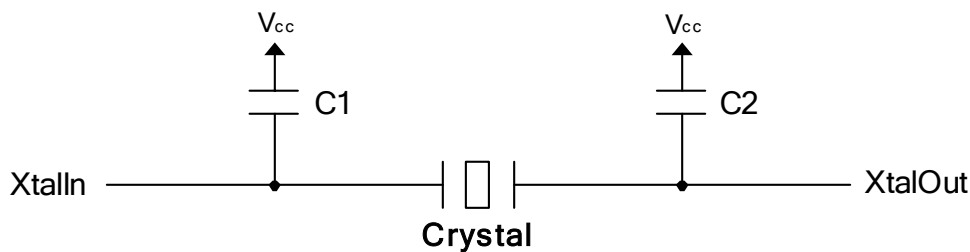

Figure 8: External Crystal Oscillator Connections

- Crystal – 32.768 kHz watch crystal such as EPSON C-002RX (12.5 pF load capacitance)
- Capacitors – C1, C2
 Use NPO-type ceramic caps
 C1 = C2 = 25 pF - (Package Cap) - (Board Parasitic Cap)

Note: Use this equation if you do not employ PLL mode. If you do employ PLL with the External Crystal Oscillator, see Application Note AN2027 under **Support** at <http://www.cypressmicro.com> for equation and details. An error of 1 pF in C1 and C2 gives about 3 ppm error in frequency.

Table 38: Typical Package Capacitances

Package	Package Capacitance
8 PDIP	0.9 pF
20 PDIP	2 pF
20 SOIC	1 pF
20 SSOP	0.5 pF
28 PDIP	2 pF
28 SOIC	1 pF
28 SSOP	0.5 pF
44 TQFP	0.5 pF
48 PDIP	5 pF
48 SSOP	0.6 pF

7.1.5 Phase-Locked Loop (PLL) Operation

The Phase-Locked Loop (PLL) function generates the system clock with crystal accuracy. It is designed to provide a 23.986 MHz oscillator when utilized with an external 32.768 kHz crystal. Although the PLL provides crystal accuracy it requires time to lock onto the reference frequency when first starting. After the External Crystal Oscillator has been selected and enabled, the following procedure should be followed to enable the PLL and allow for proper frequency lock:

1. Select a CPU frequency of 3 MHz or less.
2. Enable the PLL.
3. Wait at least 10 ms.
4. Set CPU to a faster frequency, if desired. To do this, write the bits CPU[2:0] in the OSC_CR0 register.

The CPU frequency will immediately change when these bits are set.

If the proper settings are selected in PSoC Designer, the above steps are automatically done in *boot.asm*.

7.2 System Clocking Signals

There are twelve system-clocking signals that are used throughout the device. Referenced frequencies are

based on use of 32.768 kHz crystal. The names of these signals and their definitions are as follows:

Table 39: System Clocking Signals and Definitions

Signal	Definition
48M	The direct 48 MHz output from the Internal Main Oscillator.
24M	The direct 24 MHz output from the Internal Main Oscillator.
24V1	The 24 MHz output from the Internal Main Oscillator that has been passed through a user-selectable 1 to 16 divider ($F = 24 \text{ MHz} / (1 \text{ to } 16) = 24 \text{ MHz to } 1.5 \text{ MHz}$). The divider value is found in the Oscillator Control 1 Register (OSC_CR1). Note that the divider will be N+1, based on a value of N written into the register bits.
24V2	The 24V1 signal that has been passed through an additional user-selectable 1 to 16 divider ($F = 24 \text{ MHz} / ((1 \text{ to } 16) * (1 \text{ to } 16)) = 24 \text{ MHz to } 93.7 \text{ kHz}$). The divider value is found in the Oscillator Control 1 Register (OSC_CR1). Note that the divider will be N+1, based on a value of N written into the register bits.
32K	The multiplexed output of either the Internal Low Speed Oscillator or the External Crystal Oscillator.
CPU	The output from the Internal Main Oscillator that has been passed through a divider that has 8 user selectable ratios ranging from 1:1 to 1:256, yielding frequencies ranging from 24 MHz to 93.7 kHz.
SLP	The 32K system-clocking signal that has been passed through a divider that has 4 user selectable ratios ranging from 1:2 ⁶ to 1:2 ¹⁵ , yielding frequencies ranging from 512 Hz to 1 Hz. This signal is used to clock the sleep timer period.

The following diagram shows the PSoC MCU Clock Tree of signals 48M through SLP:

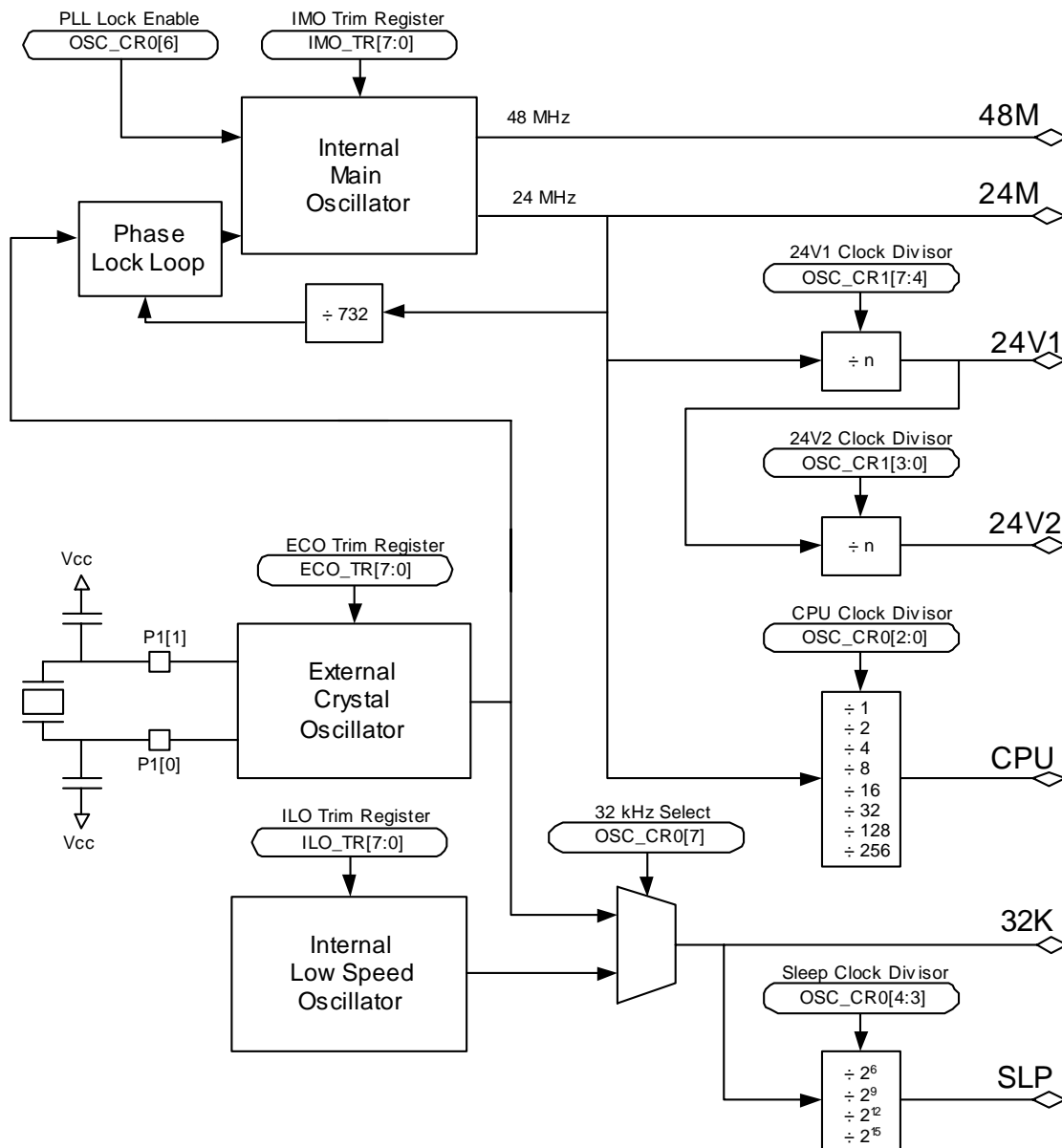

Figure 9: PSoC MCU Clock Tree of Signals

7.2.1 CPU and Sleep Timer Clock Options

The CPU is clocked off the **CPU** system-clocking signal, which can be configured to run at one of eight rates. This selection is independent from all other clock selection functions. It is completely safe for the CPU to change its clock rate without a timing hazard. The CPU clock period is determined by setting the CPU[2:0] bits in the Oscillator Control 0 Register (OSC_CR0).

The sleep timer is clocked off the **SLP** system-clocking signal. The SLEEP[1] and SLEEP[0] bits in the Oscillator Control 0 Register (OSC_CR0) allow the user to select from the four available periods.

Table 40: Oscillator Control 0 Register

Bit #	7	6	5	4	3	2	1	0
POR	0	0	0	0	0	0	0	0
Read/Write	RW	RW	RW	RW	RW	RW	RW	RW
Bit Name	32k Select	PLL Mode	Reserved	Sleep [1]	Sleep [0]	CPU [2]	CPU [1]	CPU [0]

Bit 7: 32k Select
0 = Internal low precision 32 kHz oscillator
1 = External Crystal Oscillator

Bit 6: PLL Mode
0 = Disabled
1 = Enabled, Internal Main Oscillator is locked to External Crystal Oscillator

Bit 5: Reserved

Bit [4:3]: Sleep [1:0]
0 0 = 512 Hz or 1.95 ms period
0 1 = 64 Hz or 15.6 ms period
1 0 = 8 Hz or 125 ms period
1 1 = 1 Hz or 1 s period

Bit [2:0]: CPU [2:0]
0 0 0 = 3 MHz
0 0 1 = 6 MHz
0 1 0 = 12 MHz
0 1 1 = 24 MHz
1 0 0 = 1.5 MHz
1 0 1 = 750 kHz
1 1 0 = 187.5 kHz
1 1 1 = 93.7 kHz

Oscillator Control 0 Register (OSC_CR0, Address = Bank 1, E0h)

Table 41: Oscillator Control 1 Register

Bit #	7	6	5	4	3	2	1	0
POR	0	0	0	0	0	0	0	0
Read/Write	RW	RW	RW	RW	RW	RW	RW	RW
Bit Name	24V1 [3]	24V1 [2]	24V1 [1]	24V1 [0]	24V2 [3]	24V2 [2]	24V2 [1]	24V2 [0]

Bit [7:4]: 24V1 [3:0] 4-bit data value determines the divider value for the **24V1** system-clocking signal. Note that the 4-bit data value equals n-1, where n is the desired divider value, as illustrated in [PSoC MCU Clock Tree of Signals](#). See [Table 42 on page 41](#).

Bit [3:0]: 24V2 [3:0] 4-bit data value determines the divider value for the **24V2** system-clocking signal. Note that the 4-bit data value equals n-1, where n is the desired divider value, as illustrated in the [PSoC MCU Clock Tree of Signals](#). See [Table 42 on page 41](#).

Oscillator Control 1 Register (OSC_CR1, Address = Bank 1, E1h)

7.2.2 24V1/24V2 Frequency Selection

24V1 and 24V2 based on the value written to the OSC_CR1 register.

The following table shows the resulting frequencies for

Table 42: 24V1/24V2 Frequency Selection

Reg. Value	24V1 MHz	24V2 kHz	Reg. Value	24V1 MHz	24V2 kHz	Reg. Value	24V1 MHz	24V2 kHz	Reg. Value	24V1 MHz	24V2 kHz
00	24.00	24000.00	40	4.80	4800.00	80	2.67	2666.67	C0	1.85	1846.15
01	24.00	12000.00	41	4.80	2400.00	81	2.67	1333.33	C1	1.85	923.08
02	24.00	8000.00	42	4.80	1600.00	82	2.67	888.89	C2	1.85	615.38
03	24.00	6000.00	43	4.80	1200.00	83	2.67	666.67	C3	1.85	461.54
04	24.00	4800.00	44	4.80	960.00	84	2.67	533.33	C4	1.85	369.23
05	24.00	4000.00	45	4.80	800.00	85	2.67	444.44	C5	1.85	307.69
06	24.00	3428.57	46	4.80	685.71	86	2.67	380.95	C6	1.85	263.74
07	24.00	3000.00	47	4.80	600.00	87	2.67	333.33	C7	1.85	230.77
08	24.00	2666.67	48	4.80	533.33	88	2.67	296.30	C8	1.85	205.13
09	24.00	2400.00	49	4.80	480.00	89	2.67	266.67	C9	1.85	184.62
0A	24.00	2181.82	4A	4.80	436.36	8A	2.67	242.42	CA	1.85	167.83
0B	24.00	2000.00	4B	4.80	400.00	8B	2.67	222.22	CB	1.85	153.85
0C	24.00	1846.15	4C	4.80	369.23	8C	2.67	205.13	CC	1.85	142.01
0D	24.00	1714.29	4D	4.80	342.86	8D	2.67	190.48	CD	1.85	131.87
0E	24.00	1600.00	4E	4.80	320.00	8E	2.67	177.78	CE	1.85	123.08
0F	24.00	1500.00	4F	4.80	300.00	8F	2.67	166.67	CF	1.85	115.38
10	12.00	12000.00	50	4.00	4000.00	90	2.40	2400.00	D0	1.71	1714.29
11	12.00	6000.00	51	4.00	2000.00	91	2.40	1200.00	D1	1.71	857.14
12	12.00	4000.00	52	4.00	1333.33	92	2.40	800.00	D2	1.71	571.43
13	12.00	3000.00	53	4.00	1000.00	93	2.40	600.00	D3	1.71	428.57
14	12.00	2400.00	54	4.00	800.00	94	2.40	480.00	D4	1.71	342.86
15	12.00	2000.00	55	4.00	666.67	95	2.40	400.00	D5	1.71	285.71
16	12.00	1714.29	56	4.00	571.43	96	2.40	342.86	D6	1.71	244.90
17	12.00	1500.00	57	4.00	500.00	97	2.40	300.00	D7	1.71	214.29
18	12.00	1333.33	58	4.00	444.44	98	2.40	266.67	D8	1.71	190.48
19	12.00	1200.00	59	4.00	400.00	99	2.40	240.00	D9	1.71	171.43
1A	12.00	1090.91	5A	4.00	363.64	9A	2.40	218.18	DA	1.71	155.84
1B	12.00	1000.00	5B	4.00	333.33	9B	2.40	200.00	DB	1.71	142.86
1C	12.00	923.08	5C	4.00	307.69	9C	2.40	184.62	DC	1.71	131.87
1D	12.00	857.14	5D	4.00	285.71	9D	2.40	171.43	DD	1.71	122.45
1E	12.00	800.00	5E	4.00	266.67	9E	2.40	160.00	DE	1.71	114.29
1F	12.00	750.00	5F	4.00	250.00	9F	2.40	150.00	DF	1.71	107.14
20	8.00	8000.00	60	3.43	3428.57	A0	2.18	2181.82	E0	1.60	1600.00
21	8.00	4000.00	61	3.43	1714.29	A1	2.18	1090.91	E1	1.60	800.00
22	8.00	2666.67	62	3.43	1142.86	A2	2.18	727.27	E2	1.60	533.33
23	8.00	2000.00	63	3.43	857.14	A3	2.18	545.45	E3	1.60	400.00
24	8.00	1600.00	64	3.43	685.71	A4	2.18	436.36	E4	1.60	320.00
25	8.00	1333.33	65	3.43	571.43	A5	2.18	363.64	E5	1.60	266.67
26	8.00	1142.86	66	3.43	489.80	A6	2.18	311.69	E6	1.60	228.57
27	8.00	1000.00	67	3.43	428.57	A7	2.18	272.73	E7	1.60	200.00
28	8.00	888.89	68	3.43	380.95	A8	2.18	242.42	E8	1.60	177.78
29	8.00	800.00	69	3.43	342.86	A9	2.18	218.18	E9	1.60	160.00
2A	8.00	727.27	6A	3.43	311.69	AA	2.18	198.35	EA	1.60	145.45
2B	8.00	666.67	6B	3.43	285.71	AB	2.18	181.82	EB	1.60	133.33
2C	8.00	615.38	6C	3.43	263.74	AC	2.18	167.83	EC	1.60	123.08
2D	8.00	571.43	6D	3.43	244.90	AD	2.18	155.84	ED	1.60	114.29
2E	8.00	533.33	6E	3.43	228.57	AE	2.18	145.45	EE	1.60	106.67
2F	8.00	500.00	6F	3.43	214.29	AF	2.18	136.36	EF	1.60	100.00
30	6.00	6000.00	70	3.00	3000.00	B0	2.00	2000.00	F0	1.50	1500.00
31	6.00	3000.00	71	3.00	1500.00	B1	2.00	1000.00	F1	1.50	750.00
32	6.00	2000.00	72	3.00	1000.00	B2	2.00	666.67	F2	1.50	500.00
33	6.00	1500.00	73	3.00	750.00	B3	2.00	500.00	F3	1.50	375.00
34	6.00	1200.00	74	3.00	600.00	B4	2.00	400.00	F4	1.50	300.00
35	6.00	1000.00	75	3.00	500.00	B5	2.00	333.33	F5	1.50	250.00
36	6.00	857.14	76	3.00	428.57	B6	2.00	285.71	F6	1.50	214.29
37	6.00	750.00	77	3.00	375.00	B7	2.00	250.00	F7	1.50	187.50
38	6.00	666.67	78	3.00	333.33	B8	2.00	222.22	F8	1.50	166.67
39	6.00	600.00	79	3.00	300.00	B9	2.00	200.00	F9	1.50	150.00
3A	6.00	545.45	7A	3.00	272.73	BA	2.00	181.82	FA	1.50	136.36
3B	6.00	500.00	7B	3.00	250.00	BB	2.00	166.67	FB	1.50	125.00
3C	6.00	461.54	7C	3.00	230.77	BC	2.00	153.85	FC	1.50	115.38
3D	6.00	428.57	7D	3.00	214.29	BD	2.00	142.86	FD	1.50	107.14
3E	6.00	400.00	7E	3.00	200.00	BE	2.00	133.33	FE	1.50	100.00
3F	6.00	375.00	7F	3.00	187.5	BF	2.00	125.00	FF	1.50	93.75

7.2.3 Digital PSoC Block Clocking Options

All digital PSoC block clocks are a user-selectable choice of **48M**, **24V1**, **24V2**, or **32K**, as well as clocking signals from other digital PSoC blocks or general pur-

pose I/O pins. There are a total of 16 possible clock options for each digital PSoC block. See the **Digital PSoC Block** section for details.

8.0 Interrupts

8.1 Overview

Interrupts can be generated by the General Purpose I/O lines, the Power monitor, the internal Sleep Timer, the eight Digital PSoC blocks, and the four analog columns. Every interrupt has a separate enable bit, which is contained in the General Interrupt Mask Register (INT_MSK0) and the Digital PSoC Block Interrupt Mask Register (INT_MSK1). When the user writes a "1" to a particular bit position, this enables the interrupt associated with that position. There is a single Global Interrupt Enable bit in the Flags Register (CPU_F), which can disable all interrupts, or enable those interrupts that also have their individual interrupt bit enabled. During a reset, the enable bits in the General Interrupt Mask Register (INT_MASK0), the enable bits in the Digital PSoC Block Interrupt Mask Register (INT_MSK1) and the Global Interrupt Enable bit in the Flags Register (CPU_F) are all cleared. The Interrupt Vector Register (INT_VC) holds the interrupt vector for the highest priority pending interrupt when read, and when written will clear all pending interrupts.

If there is only one interrupt pending and an instruction is executed that would mask that pending interrupt (by clearing the corresponding bit in either of the interrupt mask registers at address E0h or E1h in Bank 0), the CPU will take that interrupt. Since the pending interrupt has been cleared and there are no others, the resulting interrupt vector is 0000h and the CPU will jump to the user code at the beginning of Flash. To address this issue, use the macro defined in *m8c.inc* called "M8C_DisableIntMask" in PSoC Designer. This macro brackets the register write with a disable then an enable of global interrupts.

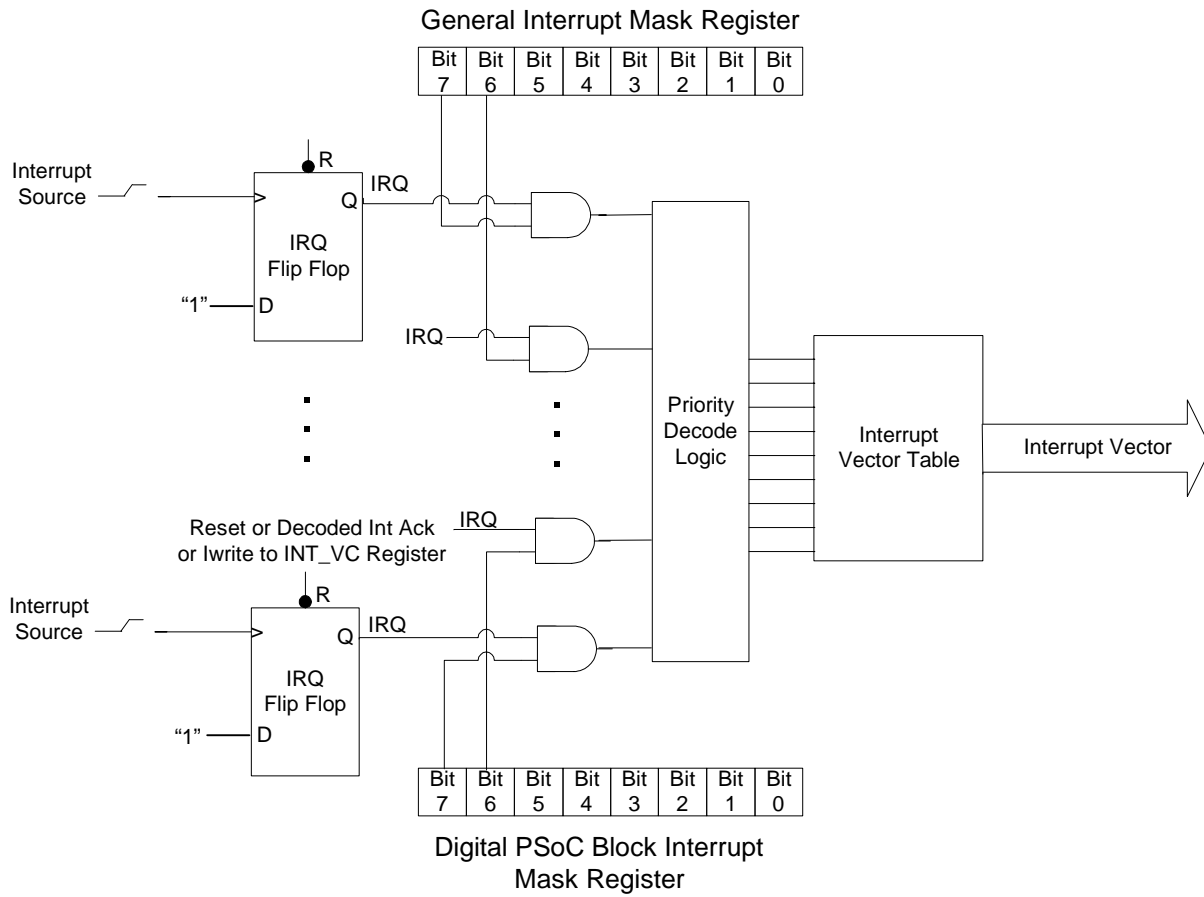

Figure 10: Interrupts Overview

8.2 Interrupt Control Architecture

The interrupt controller contains a separate flip-flop for each interrupt. When an interrupt is generated, it is registered as a pending interrupt. It will stay pending until it is serviced, a reset occurs, or there is a write to the INT_VC Register. A pending interrupt will only generate an interrupt request when enabled by the appropriate mask bit in the Digital PSoC Block Interrupt Mask Register (INT_MSK1) or General Interrupt Mask Register (INT_MSK0), and the Global IE bit in the CPU_F register is set.

Additionally, for GPIO Interrupts, the appropriate enable and interrupt-type bits for each I/O pin must be set (see section 6.0, Table 29 on page 31, Table 33 on page 33, and Table 34 on page 34). For Analog Column Interrupts, the interrupt source must be set (see section 10.10 and Table 77 on page 101).

During the servicing of any interrupt, the MSB and LSB of Program Counter and Flag registers (CPU_PC and CPU_F) are stored onto the program stack by an automatic CALL instruction (13 cycles) generated during the interrupt acknowledge process. The user firmware may preserve and restore processor state during an interrupt using the PUSH and POP instructions. The memory oriented CPU architecture requires minimal state saving during interrupts, providing very fast interrupt context switching. The Program Counter and Flag registers (CPU_PC and CPU_F) are restored when the RETI instruction is executed. If two or more interrupts are pending at the same time, the higher priority interrupt (lower priority number) will be serviced first.

After a copy of the Flag Register is stored on the stack, the Flag Register is automatically cleared. This disables all interrupts, since the Global IE flag bit is now cleared. Executing a RETI instruction restores the Flag register, and re-enables the Global Interrupt bit.

Nested interrupts can be accomplished by re-enabling interrupts inside an interrupt service routine. To do this, set the IE bit in the Flag Register. The user must store sufficient information to maintain machine state if this is done.

Each digital PSoC block has its own unique Interrupt Vector and Interrupt Enable bit. There are also individual interrupt vectors for each of the Analog columns, Supply Voltage Monitor, Sleep Timer and General Purpose I/Os.

8.3 Interrupt Vectors

Table 43: Interrupt Vector Table

Address	Interrupt Priority Number	Description
0x0004	1	Supply Monitor Interrupt Vector
0x0008	2	DBA00 PSoC Block Interrupt Vector
0x000C	3	DBA01 PSoC Block Interrupt Vector
0x0010	4	DBA02 PSoC Block Interrupt Vector
0x0014	5	DBA03 PSoC Block Interrupt Vector
0x0018	6	DCA04 PSoC Block Interrupt Vector
0x001C	7	DCA05 PSoC Block Interrupt Vector
0x0020	8	DCA06 PSoC Block Interrupt Vector
0x0024	9	DCA07 PSoC Block Interrupt Vector
0x0028	10	Acolumn 0 Interrupt Vector
0x002C	11	Acolumn 1 Interrupt Vector
0x0030	12	Acolumn 2 Interrupt Vector
0x0034	13	Acolumn 3 Interrupt Vector
0x0038	14	GPIO Interrupt Vector
0x003C	15	Sleep Timer Interrupt Vector
0x0040		On-Chip Program Memory Starts

The interrupt process vectors the Program Counter to the appropriate address in the Interrupt Vector Table. Typically, these addresses contain JMP instructions to the start of the interrupt handling routine for the interrupt.

8.4 Interrupt Masks

Table 44: General Interrupt Mask Register

Bit #	7	6	5	4	3	2	1	0
POR	0	0	0	0	0	0	0	0
Read/ Write	RW	RW	RW	RW	RW	RW	RW	RW
Bit Name	Reserved	Sleep	GPIO	Acolumn3	Acolumn2	Acolumn1	Acolumn0	Voltage Monitor

Bit 7: Reserved

Bit 6: Sleep Interrupt Enable Bit (see 11.4)

0 = Disabled

1 = Enabled

Bit 5: GPIO Interrupt Enable Bit (see 8.6)

0 = Disabled

1 = Enabled

Bit [4]: Acolumn 3 Interrupt Enable Bit (see 10.0)

0 = Disabled

1 = Enabled

Bit [3]: Acolumn 2 Interrupt Enable Bit (see 10.0)

0 = Disabled

1 = Enabled

Bit [2]: Acolumn 1 Interrupt Enable Bit (see 10.0)

0 = Disabled

1 = Enabled

Bit [1]: Acolumn 0 Interrupt Enable Bit (see 10.0)

0 = Disabled

1 = Enabled

Bit 0: Voltage Monitor Interrupt Enable Bit (see 11.5)

0 = Disabled

1 = Enabled

General Interrupt Mask Register (INT_MSK0, Address = Bank 0, E0h)

Table 45: Digital PSoC Block Interrupt Mask Register

Bit #	7	6	5	4	3	2	1	0
POR	0	0	0	0	0	0	0	0
Read/Write	RW	RW	RW	RW	RW	RW	RW	RW
Bit Name	DCA07	DCA06	DCA05	DCA04	DBA03	DBA02	DBA01	DBA00

Bit 7: DCA07 Interrupt Enable Bit
0 = Disabled
1 = Enabled

Bit 6: DCA06 Interrupt Enable Bit
0 = Disabled
1 = Enabled

Bit 5: DCA05 Interrupt Enable Bit
0 = Disabled
1 = Enabled

Bit 4: DCA04 Interrupt Enable Bit
0 = Disabled
1 = Enabled

Bit 3: DBA03 Interrupt Enable Bit
0 = Disabled
1 = Enabled

Bit 2: DBA02 Interrupt Enable Bit
0 = Disabled
1 = Enabled

Bit 1: DBA01 Interrupt Enable Bit
0 = Disabled
1 = Enabled

Bit 0: DBA00 Interrupt Enable Bit
0 = Disabled
1 = Enabled

Digital PSoC Block Interrupt Mask Register (INT_MSK1, Address = Bank 0, E1h)

8.5 Interrupt Vector Register

Table 46: Interrupt Vector Register

Bit #	7	6	5	4	3	2	1	0
POR	0	0	0	0	0	0	0	0
Read/Write	RW	RW	RW	RW	RW	RW	RW	RW
Bit Name	Data[7]	Data[6]	Data[5]	Data[4]	Data[3]	Data[2]	Data[1]	Data[0]

Bit [7:0]: Data [7:0]
8-bit data value holds the interrupt vector for the highest priority pending interrupt. Writing to this register will clear all pending interrupts

Interrupt Vector Register (INT_VC, Address = Bank 0, E2h)

8.6 GPIO Interrupt

GPIO Interrupts are polarity configurable and pin-wise maskable (within each Port's pin configuration registers). They all share the same interrupt priority and vector.

Any general purpose I/O can be used as an interrupt source. The GPIO bit in the General Interrupt Mask Register (INT_MSK0) must be set to enable pin interrupts, as well as the enable bits for each pin, which are located in

the Port x Interrupt Enable Registers (PRTxIE). There are user selectable options to generate an interrupt on 1) any change from the last read state, 2) rising edge, and 3) falling edge.

When Interrupt on Change is selected, the state of the GPIO pin is stored when the port is read. Changes from this state will then assert the interrupt, if enabled.

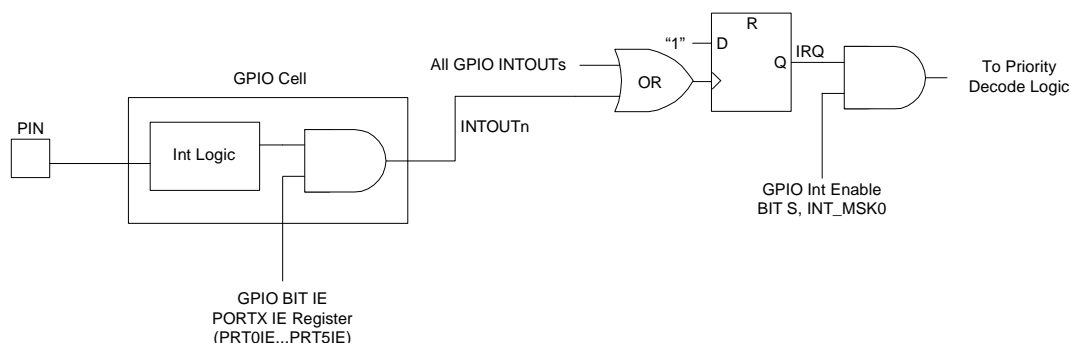

Figure 11: GPIO Interrupt Enable Diagram

For a GPIO interrupt to occur, the following steps must be taken:

1. The pin Drive Mode must be set so the pin can be an input.
2. The pin must be enabled to generate an interrupt by setting the appropriate bit in the Port interrupt Enable Register (PRTxIE).
3. The edge type for the interrupt must be set in the Port Interrupt Control 0 and Control 1 Registers (PRTxIC0 and PRTxIC1). Edge type must be set to a value other than 00.
4. The GPIO bit must be set in the General Interrupt Mask Register (INT_MSK0).
5. The Global Interrupt Enable bit must be set.
6. Because the GPIO interrupts all share the same interrupt vector, the source for the GPIO interrupt must be cleared before any other GPIO interrupt will occur (i.e., the **OR** gate in Figure 11: "ors" all of the INTOUTn signals together). If any of the INTOUTn signals are high, the flip-flop in Figure 11: will not see a rising edge and no IRQ will occur.

9.0 Digital PSoC Blocks

9.1 Introduction

PSoC blocks are user configurable system resources. On-chip digital PSoC blocks reduce the need for many MCU part types and external peripheral components. Digital PSoC blocks can be configured to provide a wide variety of peripheral functions. PSoC Designer Software Integrated Development Environment provides automated configuration of PSoC blocks by simply selecting the desired functions. PSoC Designer then generates the proper configuration information and can print a device data sheet unique to that configuration.

Digital PSoC blocks provide up to eight, 8-bit multipurpose timers/counters supporting multiple event timers, real-time clocks, Pulse Width Modulators (PWM), and CRCs. In addition to all PSoC block functions, communication PSoC blocks support full-duplex UARTs and SPI master or slave functions.

As shown in [Figure 12](#), there are a total of eight 8-bit digital PSoC blocks in this device family configured as a linear array. Four of these are the Digital Basic Type A blocks and four are the Digital Communications Type A blocks. Each of these digital PSoC blocks can be configured independently, or used in combination.

Each digital PSoC block has a unique Interrupt Vector and Interrupt Enable bit. Functions can be stopped or started with a user-accessible Enable bit.

The Timer/Counter/CRC/PRS/Deadband functions are available on the Digital Basic Type A blocks and also the Digital Communications Type A blocks. The UART and SPI communications functions are only available on the Digital Communications Type A blocks.

There are three configuration registers: the Function Register (DBA00FN-DCA07FN) to select the block function and mode, the Input Register (DBA00IN-DCA07IN) to select data input and clock selection, and the Output Register (DBA00OU-DCA07OU) to select and enable function outputs.

The three data registers are designated Data 0 (DBA00DR0-DCA07DR0), Data 1 (DBA00DR1-DCA07DR1), and Data 2 (DBA00DR2-DCA07DR2). The function of these registers and their bit mapping is

dependent on the overall block function selected by the user.

The one Control Register (DBA00CR0-DCA07CR0) is designated Control 0. The function of this register and its bit mapping is dependent on the overall block function selected by the user.

If the CPU frequency is 24 MHz and a PSoC timer/counter of 24-bits or longer is operating at 48 MHz, a write to the block Control Register to enable it (for example, a call to `Timer_1_Start`) may not start the block properly. In the failure case, the first count will typically be indeterminate as the upper bytes fail to make the first count correctly. However, on the first terminal count, the correct period will be loaded and counted thereafter.

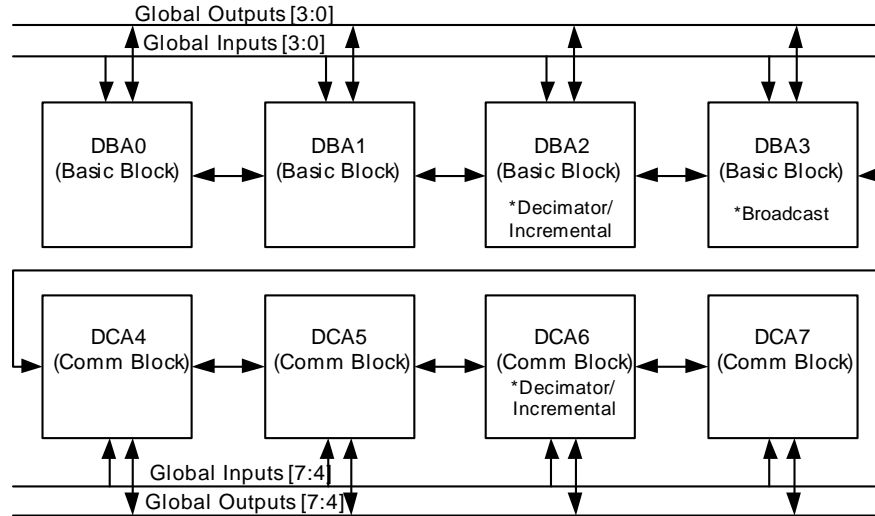

Figure 12: Digital Basic and Digital Communications PSoC Blocks

*Three of the digital blocks have special functions. DBA3 is a Broadcast block, with output directly available to all digital blocks as a clock or data input. Blocks DBA2 and DCA6 have selectable connections to support Delta Sigma and Incremental A/D converters.

9.2 Digital PSoC Block Bank 1 Registers

9.2.1 Digital Basic Type A / Communications Type A Block xx Function Register

The Digital Basic Type A / Communications Type A Block xx Function Register (DBA00FN-DCA07FN) consists of 3 bits [2:0] to select the block function, 2 bits [4:3] to select mode of operation, and 1 bit [5] to indicate the last block in a group of chained blocks.

Table 47: Digital Basic Type A/ Communications Type A Block xx Function Register

Bit #	7	6	5	4	3	2	1	0
POR	0	0	0	0	0	0	0	0
Read/Write	RW	RW	RW	RW	RW	RW	RW	RW
Bit Name	Reserved	Reserved	End	Mode 1	Mode 0	Function [2]	Function [1]	Function [0]

Bit 7: Reserved
Bit 6: Reserved

Bit 5: End
0 = PSoC block is not the end of a chained function (End should not be set to 0 in block DCA07)
1 = PSoC block is the end of a chained function, or is an unchained PSoC block

Bit 4: Mode 1 The definition of the Mode [1] bit depends on the block function selected
Timer: The Mode [1] bit signifies the Compare Type
0 = Less Than or Equal
1 = Less Than
Counter: The Mode [1] bit signifies the Compare Type
0 = Less Than or Equal
1 = Less Than
CRC/PRS: The Mode [1] bit is unused in this function
Deadband: The Mode [1] bit is unused in this function
UART: The Mode[1] bit signifies the Interrupt Type (Transmitter only)
0 = Transmit: Interrupt on TX_Reg Empty
1 = Transmit: Interrupt on TX Complete
SPI: The Mode[1] bit signifies the Interrupt Type
0 = Master: Interrupt on TX Reg Empty, Slave: Interrupt on RX Reg Full
1 = Master: Interrupt on SPI Complete, Slave: Interrupt on SPI Complete

Bit 3: Mode 0 The definition of the Mode [0] bit depends on the block function selected
Timer: The Mode [0] bit signifies Interrupt Type
0 = Terminal Count
1 = Compare True
Counter: The Mode [0] bit signifies Interrupt Type
0 = Terminal Count
1 = Compare True
CRC/PRS: The Mode [0] bit is unused in this function
Deadband: The Mode [0] bit is unused in this function
UART: The Mode [0] bit signifies the Direction
0 = Receive
1 = Transmit
SPI: The Mode [0] bit signifies the Type
0 = Master
1 = Slave

Bit [2:0]: Function [2:0] The Function [2:0] bits select the block function which determines the basic hardware configuration
0 0 0 = Timer (chainable)
0 0 1 = Counter (chainable)
0 1 0 = CRC/PRS (Cyclical Redundancy Checker or Pseudo Random Sequencer) (chainable)
0 1 1 = Reserved
1 0 0 = Deadband for Pulse Width Modulator
1 0 1 = UART (function only available on DCA type blocks)
1 1 0 = SPI (function only available on DCA type blocks)
1 1 1 = Reserved

Digital Basic Type A Block 00 Function Register	(DBA00FN, Address = Bank 1, 20h)
Digital Basic Type A Block 01 Function Register	(DBA01FN, Address = Bank 1, 24h)
Digital Basic Type A Block 02 Function Register	(DBA02FN, Address = Bank 1, 28h)
Digital Basic Type A Block 03 Function Register	(DBA03FN, Address = Bank 1, 2Ch)
Digital Communications Type A Block 04 Function Register	(DCA04FN, Address = Bank 1, 30h)

Digital Communications Type A Block 05 Function Register (DCA05FN, Address = Bank 1, 34h)
 Digital Communications Type A Block 06 Function Register (DCA06FN, Address = Bank 1, 38h)
 Digital Communications Type A Block 07 Function Register (DCA07FN, Address = Bank 1, 3Ch)

9.2.2 Digital Basic Type A / Communications Type A Block xx Input Register

The Digital Basic Type A / Communications Type A Block xx Input Register (DBA00IN-DCA07IN) consists of 4 bits [3:0] to select the block input clock and 4 bits [7:4] to select the primary data/enable input. The actual usage of the input data/enable is function dependent.

Table 48: Digital Basic Type A / Communications Type A Block xx Input Register

Bit #	7	6	5	4	3	2	1	0
POR	0	0	0	0	0	0	0	0
Read/Write	RW	RW	RW	RW	RW	RW	RW	RW
Bit Name	Data [3]	Data [2]	Data [1]	Data [0]	Clock [3]	Clock [2]	Clock [1]	Clock [0]
<p>Bit [7:4]: Data [3:0] Data Enable Source Select 0 0 0 0 = Data = 0 0 0 0 1 = Data = 1 0 0 1 0 = Digital Block 03 0 0 1 1 = Chain Function to Previous Block 0 1 0 0 = Analog Column Comparator 0 0 1 0 1 = Analog Column Comparator 1 0 1 1 0 = Analog Column Comparator 2 0 1 1 1 = Analog Column Comparator 3 1 0 0 0 = Global Output[0] (for Digital Blocks 00 to 03) or Global Output[4] (for Digital Blocks 04 to 07) 1 0 0 1 = Global Output[1] (for Digital Blocks 00 to 03) or Global Output[5] (for Digital Blocks 04 to 07) 1 0 1 0 = Global Output[2] (for Digital Blocks 00 to 03) or Global Output[6] (for Digital Blocks 04 to 07) 1 0 1 1 = Global Output[3] (for Digital Blocks 00 to 03) or Global Output[7] (for Digital Blocks 04 to 07) 1 1 0 0 = Global Input[0] (for Digital Blocks 00 to 03) or Global Input[4] (for Digital Blocks 04 to 07) 1 1 0 1 = Global Input[1] (for Digital Blocks 00 to 03) or Global Input[5] (for Digital Blocks 04 to 07) 1 1 1 0 = Global Input[2] (for Digital Blocks 00 to 03) or Global Input[6] (for Digital Blocks 04 to 07) 1 1 1 1 = Global Input[3] (for Digital Blocks 00 to 03) or Global Input[7] (for Digital Blocks 04 to 07)</p> <p>Bit [3:0]: Clock [3:0] Clock Source Select 0 0 0 0 = Clock Disabled 0 0 0 1 = Global Output[4] (for Digital Blocks 00 to 03) or Global Output[0] (for Digital Blocks 04 to 07) 0 0 1 0 = Digital Block 03 (Primary Output) 0 0 1 1 = Previous Digital PSoC block (Primary Output) 0 1 0 0 = 48M 0 1 0 1 = 24V1 0 1 1 0 = 24V2 0 1 1 1 = 32k 1 0 0 0 = Global Output[0] (for Digital Blocks 00 to 03) or Global Output[4] (for Digital Blocks 04 to 07) 1 0 0 1 = Global Output[1] (for Digital Blocks 00 to 03) or Global Output[5] (for Digital Blocks 04 to 07) 1 0 1 0 = Global Output[2] (for Digital Blocks 00 to 03) or Global Output[6] (for Digital Blocks 04 to 07) 1 0 1 1 = Global Output[3] (for Digital Blocks 00 to 03) or Global Output[7] (for Digital Blocks 04 to 07) 1 1 0 0 = Global Input[0] (for Digital Blocks 00 to 03) or Global Input[4] (for Digital Blocks 04 to 07) 1 1 0 1 = Global Input[1] (for Digital Blocks 00 to 03) or Global Input[5] (for Digital Blocks 04 to 07) 1 1 1 0 = Global Input[2] (for Digital Blocks 00 to 03) or Global Input[6] (for Digital Blocks 04 to 07) 1 1 1 1 = Global Input[3] (for Digital Blocks 00 to 03) or Global Input[7] (for Digital Blocks 04 to 07)</p>								

Digital Basic Type A Block 00 Input Register (DBA00IN, Address = Bank 1, 21h)
 Digital Basic Type A Block 01 Input Register (DBA01IN, Address = Bank 1, 25h)
 Digital Basic Type A Block 02 Input Register (DBA02IN, Address = Bank 1, 29h)
 Digital Basic Type A Block 03 Input Register (DBA03IN, Address = Bank 1, 2Dh)
 Digital Communications Type A Block 04 Input Register (DCA04IN, Address = Bank 1, 31h)
 Digital Communications Type A Block 05 Input Register (DCA05IN, Address = Bank 1, 35h)

Digital Communications Type A Block 06 Input Register
 Digital Communications Type A Block 07 Input Register

(DCA06IN, Address = Bank 1, 39h)
 (DCA07IN, Address = Bank 1, 3Dh)

The Data/Enable source select [3:0] bits select between multiple inputs to the Digital PSoC Blocks. These inputs serve as Clock Enables or Data Input depending on the Digital PSoC Block's programmed function. If "Chain Function to Previous" data input is selected for Data/Enable then the selected Digital PSoC block receives its Data, Enable, Zero Detect, and all chaining information from the previous digital PSoC block. The data inputs that are selected from the GPIO pins (through the Global Input Bus) are synchronized to the 24 MHz clock. The following table shows the function dependent meaning of the data input.

Table 49: Digital Function Data Input Definitions

Function	Data Input
Timer	Positive Edge Capture
Counter	Count Enable (Active High)
CRC	Data Input
PRS	N/A
Deadband	Kill Signal (Active High)
TX UART	N/A
RX UART	RX Data In
SPI Master	MISO (Master In/Slave Out)
SPI Slave	MOSI (Master Out/Slave In)

The Clock[3:0] bits select multiple sources for the clock for each digital PSoC block. The sources for each digital PSoC block clock are selected from the Global Input Bus, System Clocks, and other neighboring digital PSoC blocks. As shown in the table, Digital PSoC Blocks 0-3 can interface to Global I/Os 00-03, and Digital PSoC block 04-07 can interface to Global I/Os 4-7. It is important to note that clock inputs selected from the GPIO pins (through the Global Input Bus) are not synchronized. This may cause indeterminate results if the CPU reads a block register as it is changing in response to an external clock. CPU reads must be manually synchronized, either through the block interrupt, or through a multiple read and voting scheme.

9.2.3 Digital Basic Type A / Communications Type A Block xx Output Register

The digital PSoC block's outputs can be selected to drive associated Global Output Bus signals via the Output Select bits. In addition, the output drive can be selectively enabled in this register. The SPI Slave has an auxiliary input which is also controlled by selections in this register.

Table 50: Digital Basic Type A / Communications Type A Block xx Output Register

Bit #	7	6	5	4	3	2	1	0
POR	0	0	0	0	0	0	0	0
Read/ Write	RW	RW	RW	RW	RW	RW	RW	RW
Bit Name	Reserved	Reserved	AUX Out Enable	AUX IO Sel [1]	AUX IO Sel [0]	Out Enable	Out Sel [1]	Out Sel [0]

Bit 7: Reserved

Bit 6: Reserved

Bit 5: AUX Out Enable

0 = Disable Auxiliary Output

1 = Enable Auxiliary Output (function dependent)

Bit [4:3]: AUX IO Sel [1:0] Function-dependent selection of auxiliary input or output

0 0 = Drive Global Output[0] (for Digital Blocks 00 to 03) **or**
Input from Global Input[4] or Drive Global Output [4] (for Digital Blocks 04 to 07)

0 1 = Drive Global Output[1] (for Digital Blocks 00 to 03) **or**
Input from Global Input[5] or Drive Global Output[5] (for Digital Blocks 04 to 07)

1 0 = Drive Global Output[2] (for Digital Blocks 00 to 03) **or**
Input from Global Input[6] or Drive Global Output[6] (for Digital Blocks 04 to 07)

1 1 = Drive Global Output[3] (for Digital Blocks 00 to 03) **or**
Input from Global Input[7] or Drive Global Output[7] (for Digital Blocks 04 to 07)

Bit 2: Out Enable

0 = Disable Primary Output

1 = Enable Primary Output (function dependant)

Bit [1:0]: Out Sel [1:0] Primary Output

0 0 = Drive Global Output[0] (for Digital Blocks 00 to 03) **or** Drive Global Output[4] (for Digital Blocks 04 to 07)

0 1 = Drive Global Output[1] (for Digital Blocks 00 to 03) **or** Drive Global Output[5] (for Digital Blocks 04 to 07)

1 0 = Drive Global Output[2] (for Digital Blocks 00 to 03) **or** Drive Global Output[6] (for Digital Blocks 04 to 07)

1 1 = Drive Global Output[3] (for Digital Blocks 00 to 03) **or** Drive Global Output[7] (for Digital Blocks 04 to 07)

Digital Basic Type A Block 00 Output Register	(DBA00OU, Address = Bank 1, 22h)
Digital Basic Type A Block 01 Output Register	(DBA01OU, Address = Bank 1, 26h)
Digital Basic Type A Block 02 Output Register	(DBA02OU, Address = Bank 1, 2Ah)
Digital Basic Type A Block 03 Output Register	(DBA03OU, Address = Bank 1, 2Eh)
Digital Communications Type A Block 04 Output Register	(DCA04OU, Address = Bank 1, 32h)
Digital Communications Type A Block 05 Output Register	(DCA05OU, Address = Bank 1, 36h)
Digital Communications Type A Block 06 Output Register	(DCA06OU, Address = Bank 1, 3Ah)
Digital Communications Type A Block 07 Output Register	(DCA07OU, Address = Bank 1, 3Eh)

The Primary Output is the source for “Previous Digital PSoC Block” or “Digital Block 03,” selections for the “Clock Source Select” in the Digital Basic Type A/Communications Type A Block xx Input Register ([Table 48 on page 51](#)).

A digital PSoC block may have 0, 1, or 2 outputs depending on its function, as shown in the following table:

Table 51: Digital Function Outputs

Function	Primary Output	Auxiliary Output	Auxiliary Input
Timer	Terminal Count	Compare True	N/A
Counter	Compare True	Terminal Count	N/A
CRC	N/A	Compare True	N/A
PRS	Serial Data	Compare True	N/A
Deadband	F0	F1	N/A
TX UART	TX Data Out	N/A	N/A
RX UART	N/A	N/A	N/A
SPI Master	MOSI	SCLK	N/A
SPI Slave	MISO	N/A	SS_

9.3 Digital PSoC Block Bank 0 Registers

There are four user registers within each digital PSoC block: three data registers, and one status/control register. The three data registers are DR0, which is a shifter/counter, and DR1 and DR2 registers, which contain data

used during the operation. The status/control register (CR0) contains an enable bit that is used for all configurations. In addition, it contains function-specific status and control, which is outlined below.

9.3.1 Digital Basic Type A / Communications Type A Block xx Data Register 0,1,2

Table 52: Digital Basic Type A / Communications Type A Block xx Data Register 0,1,2

Bit #	7	6	5	4	3	2	1	0
POR	0	0	0	0	0	0	0	0
Read/Write	VF ¹	VF ¹	VF ¹	VF ¹	VF ¹	VF ¹	VF ¹	VF ¹
Bit Name	Data [7]	Data [6]	Data [5]	Data [4]	Data [3]	Data [2]	Data [1]	Data [0]
Bit [7:0]: Data [7:0]								

1. Varies by function/User Module selection. (See [Table 53 on page 55.](#))

Digital Basic Type A Block 00 Data Register 0	(DBA00DR0, Address = Bank 0, 20h)
Digital Basic Type A Block 00 Data Register 1	(DBA00DR1, Address = Bank 0, 21h)
Digital Basic Type A Block 00 Data Register 2	(DBA00DR2, Address = Bank 0, 22h)
Digital Basic Type A Block 01 Data Register 0	(DBA01DR0, Address = Bank 0, 24h)
Digital Basic Type A Block 01 Data Register 1	(DBA01DR1, Address = Bank 0, 25h)
Digital Basic Type A Block 01 Data Register 2	(DBA01DR2, Address = Bank 0, 26h)
Digital Basic Type A Block 02 Data Register 0	(DBA02DR0, Address = Bank 0, 28h)
Digital Basic Type A Block 02 Data Register 1	(DBA02DR1, Address = Bank 0, 29h)
Digital Basic Type A Block 02 Data Register 2	(DBA02DR2, Address = Bank 0, 2Ah)
Digital Basic Type A Block 03 Data Register 0	(DBA03DR0, Address = Bank 0, 2Ch)
Digital Basic Type A Block 03 Data Register 1	(DBA03DR1, Address = Bank 0, 2Dh)
Digital Basic Type A Block 03 Data Register 2	(DBA03DR2, Address = Bank 0, 2Eh)
Digital Communications Type A Block 04 Data Register 0	(DCA04DR0, Address = Bank 0, 30h)
Digital Communications Type A Block 04 Data Register 1	(DCA04DR1, Address = Bank 0, 31h)
Digital Communications Type A Block 04 Data Register 2	(DCA04DR2, Address = Bank 0, 32h)
Digital Communications Type A Block 05 Data Register 0	(DCA05DR0, Address = Bank 0, 34h)
Digital Communications Type A Block 05 Data Register 1	(DCA05DR1, Address = Bank 0, 35h)
Digital Communications Type A Block 05 Data Register 2	(DCA05DR2, Address = Bank 0, 36h)
Digital Communications Type A Block 06 Data Register 0	(DCA06DR0, Address = Bank 0, 38h)
Digital Communications Type A Block 06 Data Register 1	(DCA06DR1, Address = Bank 0, 39h)

Digital Communications Type A Block 06 Data Register 2 (DCA06DR2, Address = Bank 0, 3Ah)
 Digital Communications Type A Block 07 Data Register 0 (DCA07DR0, Address = Bank 0, 3Ch)
 Digital Communications Type A Block 07 Data Register 1 (DCA07DR1, Address = Bank 0, 3Dh)
 Digital Communications Type A Block 07 Data Register 2 (DCA07DR2, Address = Bank 0, 3Eh)

Table 53: R/W Variations per User Module Selection

Function	DR0	R/W	DR1	R/W	DR2	R/W
Timer	Count	R ¹	Period Value	W	Capture Value	RW
Counter	Count	R ¹	Period Value	W	Compare Value	RW
CRC	Current Value/CRC Residue	R ¹	Polynomial Mask Value	W	Seed Value	RW
PRS	Current Value	R ¹	Polynomial Mask Value	W	Seed Value	RW
Deadband	Count	R ¹	Period Value	W	Not Used	RW
RX UART	Shifter	NA	Not Used	NA	Data Register	R
TX UART	Shifter	NA	Data Register	W	Not Used	NA
SPI	Shifter	NA	TX Data Register		RX Data Register	R

1. Each time the register is read, its value is written to the DR2 register.

9.3.2 Digital Basic Type A / Communications Type A Block xx Control Register 0

Table 54: Digital Basic Type A / Communications Type A Block xx Control Register 0

Bit #	7	6	5	4	3	2	1	0
POR	0	0	0	0	0	0	0	0
Read/Write	VF ¹	VF ¹	VF ¹	VF ¹	VF ¹	VF ¹	VF ¹	VF ¹
Bit Name	Data [7]	Data [6]	Data [5]	Data [4]	Data [3]	Data [2]	Data [1]	Data [0]
Bit [7:0]: <u>Data [7:0]</u>								

1. Varies by function.

Digital Basic Type A Block 00 Control Register 0 (DBA00CR0, Address = Bank 0, 23h)
 Digital Basic Type A Block 01 Control Register 0 (DBA01CR0, Address = Bank 0, 27h)
 Digital Basic Type A Block 02 Control Register 0 (DBA02CR0, Address = Bank 0, 2Bh)
 Digital Basic Type A Block 03 Control Register 0 (DBA03CR0, Address = Bank 0, 2Fh)
 Digital Communications Type A Block 04 Control Register 0 (DCA04CR0, Address = Bank 0, 33h)
 Digital Communications Type A Block 05 Control Register 0 (DCA05CR0, Address = Bank 0, 37h)
 Digital Communications Type A Block 06 Control Register 0 (DCA06CR0, Address = Bank 0, 3Bh)
 Digital Communications Type A Block 07 Control Register 0 (DCA07CR0, Address = Bank 0, 3Fh)

9.3.3 Digital Basic Type A/Communications Type A Block xx Control Register 0 When Used as Timer, Counter, CRC, and Deadband

Note that the data in this register, as well as the following variables selected in the associated Digital Basic Type A/Communications Type A Block xx Control Register 0, are a mapping of the functions of the three registers, are a mapping of the functions of the

Table 55: Digital Basic Type A/Communications Type A Block xx Control Register 0...

Bit #	7	6	5	4	3	2	1	0
POR	--	--	--	--	--	--	--	0
Read/Write	--	--	--	--	--	--	--	RW
Bit Name	Reserved	Reserved	Reserved	Reserved	Reserved	Reserved	Reserved	Enable

Bit 7: Reserved
Bit 6: Reserved
Bit 5: Reserved
Bit 4: Reserved
Bit 3: Reserved
Bit 2: Reserved
Bit 1: Reserved

Bit 0: Enable
0 = Function Disabled
1 = Function Enabled

Digital Basic Type A Block 00 Control Register 0	(DBA00CR0, Address = Bank 0, 23h)
Digital Basic Type A Block 01 Control Register 0	(DBA01CR0, Address = Bank 0, 27h)
Digital Basic Type A Block 02 Control Register 0	(DBA02CR0, Address = Bank 0, 2Bh)
Digital Basic Type A Block 03 Control Register 0	(DBA03CR0, Address = Bank 0, 2Fh)
Digital Communications Type A Block 04 Control Register 0	(DCA04CR0, Address = Bank 0, 33h)
Digital Communications Type A Block 05 Control Register 0	(DCA05CR0, Address = Bank 0, 37h)
Digital Communications Type A Block 06 Control Register 0	(DCA06CR0, Address = Bank 0, 3Bh)
Digital Communications Type A Block 07 Control Register 0	(DCA07CR0, Address = Bank 0, 3Fh)

9.3.4 Digital Communications Type A Block xx Control Register 0 When Used as UART Transmitter

Table 56: Digital Communications Type A Block xx Control Register 0...

Bit #	7	6	5	4	3	2	1	0
POR	0	0	0	0	0	0	0	0
Read/Write	--	--	R	R	--	RW	RW	RW
Bit Name	Reserved	Reserved	TX Complete	TX Reg Empty	Reserved	Parity Type	Parity Enable	Enable

Bit 7: Reserved

Bit 6: Reserved

Bit 5: TX Complete

0 = Indicates that if a transmission has been initiated, it is still in progress

1 = Indicates that the current transmission is complete (including framing bits)

Optional interrupt source for TX UART. Reset when this register is read.

Bit 4: TX Reg Empty

0 = Indicates TX Data register is not available to accept another byte (writing to register will cause data to be lost)

1 = Indicates TX Data register is available to accept another byte

Note that the interrupt does not occur until at least 1 byte has been previously written to the TX Data Register
Default interrupt source for TX UART. Reset when the TX Data Register (Data Register 1) is written.

Bit 3: Reserved

Bit 2: Parity Type

0 = Even

1 = Odd

Bit 1: Parity Enable

0 = Parity Disabled

1 = Parity Enabled

Bit 0: Enable

0 = Function Disabled

1 = Function Enabled

Digital Communications Type A Block 04 Control Register 0

(DCA04CR0, Address = Bank 0, 33h)

Digital Communications Type A Block 05 Control Register 0

(DCA05CR0, Address = Bank 0, 37h)

Digital Communications Type A Block 06 Control Register 0

(DCA06CR0, Address = Bank 0, 3Bh)

Digital Communications Type A Block 07 Control Register 0

(DCA07CR0, Address = Bank 0, 3Fh)

9.3.5 Digital Communications Type A Block xx Control Register 0 When Used as UART Receiver

Table 57: Digital Communications Type A Block xx Control Register 0...

Bit #	7	6	5	4	3	2	1	0
POR	0	0	0	0	0	0	0	0
Read/Write	R	R	R	R	R	RW	RW	RW
Bit Name	Parity Error	Overrun	Framing Error	RX Active	RX Reg Full	Parity Type	Parity Enable	Enable

Bit 7: Parity Error

0 = Indicates no parity error detected in the last byte received

1 = Indicates a parity error detected in the last byte received

Reset when this register is read

Bit 6: Overrun

0 = Indicates that no overrun has taken place

1 = Indicates the RX Data register was overwritten with a new byte before the previous one had been read

Reset when this register is read

Bit 5: Framing Error

0 = Indicates correct stop bit

1 = Indicates a missing STOP bit

Reset when this register is read

Bit 4: RX Active

0 = Indicates no communication currently in progress

1 = Indicates a start bit has been received and a byte is currently being received

Bit 3: RX Reg Full

0 = Indicates the RX Data register is empty

1 = Indicates a byte has been loaded into the RX Data register

Interrupt source for RXUART. Reset when the RX Data register is read (Data Register 2)

Bit 2: Parity Type

0 = Even

1 = Odd

Bit 1: Parity Enable

0 = Parity Disabled

1 = Parity Enabled

Bit 0: Enable

0 = Function Disabled

1 = Function Enabled

Digital Communications Type A Block 04 Control Register 0

(DCA04CR0, Address = Bank 0, 33h)

Digital Communications Type A Block 05 Control Register 0

(DCA05CR0, Address = Bank 0, 37h)

Digital Communications Type A Block 06 Control Register 0

(DCA06CR0, Address = Bank 0, 3Bh)

Digital Communications Type A Block 07 Control Register 0

(DCA07CR0, Address = Bank 0, 3Fh)

9.3.6 Digital Communications Type A Block xx Control Register 0 When Used as SPI Transceiver

Table 58: Digital Communications Type A Block xx Control Register 0...

Bit #	7	6	5	4	3	2	1	0
POR	0	0	0	0	0	0	0	0
Read/Write	RW	R	R	R	R	RW	RW	RW
Bit Name	LSB First	Overrun	SPI Complete	TX Reg Empty	RX Reg Full	Clock Phase	Clock Polarity	Enable

Bit 7: LSB First

0 = MSB First
1 = LSB First

Bit 6: Overrun

0 = Indicates that no overrun has taken place
1 = Indicates the RX Data register was overwritten with a new byte before the previous one had been read
Reset when this register is read

Bit 5: SPI Complete

0 = Indicates the byte is in process of shifting out
1 = Indicates the byte has been shifted out (reset when register is read)
Optional interrupt source for both SPI Master and SPI Slave. Reset when this register is read

Bit 4: TX Reg Empty

0 = Indicates the TX Data register is not available to accept another byte
1 = Indicates the TX Data register is available to accept another byte
Default interrupt source for SPI Master. Reset when the TX Data Register (Data Register 1) is written.

Bit 3: RX Reg Full

0 = Indicates the RX Data register is empty
1 = Indicates a byte has been loaded into the RX Data register
Default interrupt source for SPI Slave. Reset when the RX Data Register (Data Register 2) is read

Bit 2: Clock Phase

0 = Data changes on leading edge and is latched on trailing edge
1 = Data is latched on leading edge and is changed on trailing edge

Bit 1: Clock Polarity

0 = Non-inverted (clock idle state is low)
1 = Inverted (clock idle state is high)

Bit 0: Enable

0 = Function Disabled
1 = Function Enabled

Digital Communications Type A Block 04 Control Register 0
Digital Communications Type A Block 05 Control Register 0
Digital Communications Type A Block 06 Control Register 0
Digital Communications Type A Block 07 Control Register 0

(DCA04CR0, Address = Bank 0, 33h)
(DCA05CR0, Address = Bank 0, 37h)
(DCA06CR0, Address = Bank 0, 3Bh)
(DCA07CR0, Address = Bank 0, 3Fh)

9.4 Global Inputs and Outputs

Global Inputs and Outputs provide additional capability to route clock and data signals to the digital PSoC blocks. Digital PSoC blocks are connected to the global input and output lines by configuring the PSoC block Input and Output registers (DBA00IN-DCA07IN, DBA00OU-DCA07OU). These global input and output lines form an 8-bit global input bus and an 8-bit global output bus. Four Digital PSoC blocks have access to the upper half of these buses, while the other four access the lower half, per the configuration register. These global input/output buses may be connected to the I/O pins on a per-pin basis using the pin configuration registers.

This allows digital PSoC blocks to route their inputs and outputs to pins using the global I/O buses.

9.4.1 Input Assignments

The PSoC block Input Register defines the selection of Global Inputs to digital PSoC blocks. Only 4 of the Global Inputs bus lines are available as selections to a given digital PSoC block as shown in the table below. Once the Global Input has been selected using the PSoC block Input Register selection bits, a GPIO pin must be configured to drive the selected Global Input. This configuration may be set in the Port Global Select Register. The GPIO direction must also be set to input mode by configuring the Port Drive Mode Registers to select High Z.

Table 59: Global Input Assignments

Global Input [7]	Global Input [6]	Global Input [5]	Global Input [4]	Global Input [3]	Global Input [2]	Global Input [1]	Global Input [0]
Port x[7]	Port x[6]	Port x[5]	Port x[4]	Port x[3]	Port x[2]	Port x[1]	Port x[0]
PSoC Block 04 PSoC Block 05 PSoC Block 06 PSoC Block 07	PSoC Block 04 PSoC Block 05 PSoC Block 06 PSoC Block 07	PSoC Block 04 PSoC Block 05 PSoC Block 06 PSoC Block 07	PSoC Block 04 PSoC Block 05 PSoC Block 06 PSoC Block 07	PSoC Block 00 PSoC Block 01 PSoC Block 02 PSoC Block 03	PSoC Block 00 PSoC Block 01 PSoC Block 02 PSoC Block 03	PSoC Block 00 PSoC Block 01 PSoC Block 02 PSoC Block 03	PSoC Block 00 PSoC Block 01 PSoC Block 02 PSoC Block 03

9.4.2 Output Assignments

The PSoC block Output Register defines the selection of the Global Output bus line to be driven by the digital PSoC blocks. Only 4 of the Global Output bus lines are available as selections to a given digital PSoC block as shown in the table below. The Global Output bus has two functions. Since Global Outputs are also selectable as inputs to digital PSoC blocks, signals can be routed between blocks using this bus. In addition, Global Out-

puts may drive out to GPIO pins. In this case, once the Global Output has been selected using the PSoC block Output Register selection bits, a GPIO pin must be configured to select the Global Output to drive to the pin. This configuration may be set in the Port Global Select Register. The GPIO direction must also be set to output mode (which is the default) by configuring the Port Drive Mode Registers to one of the available driving strengths.

Table 60: Global Output Assignments

Global Output [7]	Global Output [6]	Global Output [5]	Global Output [4]	Global Output [3]	Global Output [2]	Global Output [1]	Global Output [0]
Port x[7]	Port x[6]	Port x[5]	Port x[4]	Port x[3]	Port x[2]	Port x[1]	Port x[0]
PSoC Block 04 PSoC Block 05 PSoC Block 06 PSoC Block 07	PSoC Block 04 PSoC Block 05 PSoC Block 06 PSoC Block 07	PSoC Block 04 PSoC Block 05 PSoC Block 06 PSoC Block 07	PSoC Block 04 PSoC Block 05 PSoC Block 06 PSoC Block 07	PSoC Block 00 PSoC Block 01 PSoC Block 02 PSoC Block 03	PSoC Block 00 PSoC Block 01 PSoC Block 02 PSoC Block 03	PSoC Block 00 PSoC Block 01 PSoC Block 02 PSoC Block 03	PSoC Block 00 PSoC Block 01 PSoC Block 02 PSoC Block 03

9.5 Available Programmed Digital Functionality

9.5.1 Timer with Optional Capture

9.5.1.1 Summary

The timer function continuously measures the amount of time in “ticks” between two events, and provides a rate

generator. A down counter lies at the heart of the timer functions. Rate generators divide their clock source by an integer value. Hardware or software generated events

trigger capture operations that permit calculation of elapsed “ticks.” Timer-configured PSoC blocks may be chained to arbitrary lengths in 8 bit increments.

9.5.1.2 Registers

Data Register 1 establishes the period or integer clock division value. Data Register 0 holds the current state of the down counter. If the function is disabled, writing a period into Data Register 1, will automatically load Data Register 0. It is also automatically reloaded on the clock cycle after it reaches zero, the terminal count value. When a capture event occurs, the current value of Data Register 0 is transferred to Data Register 2. The captured value in Data Register 2 may then be read by the CPU. In addition to the hardware capture input, A CPU read of Data Register 0 generates a software capture event. This read will return 0 as data. A subsequent read of Data Register 2 will return the captured value. Control Register 0 contains one bit to enable/disable the function.

9.5.1.3 Inputs

There are two inputs, the Source Clock and the Hardware Capture signal. The down counter is decremented on the rising-edge of the Source Clock. A hardware capture event is signaled by a rising edge of the Hardware Capture signal. This is synchronized to the 24 MHz system clock and the data is synchronously transferred to Data Register 2. The Hardware Capture Signal is OR'ed with a software capture signal that is generated when Data Register 0 is read directly by the CPU. In order to use the software capture mechanism, the Hardware Capture signal input selection must be low. The multiplexers selecting these input sources are controlled by the PSoC block Input Register (DBA001N-DCA071N).

9.5.1.4 Outputs

The Terminal Count signal is the primary output and it exhibits a duty cycle that is the reciprocal of the period value contained in Data Register 1. In other words, it is high during the source clock cycle when the value in Data Register 0 is zero and low otherwise. The Terminal Count can be routed to additional analog or digital PSoC blocks or via Global Output lines. The auxiliary output is the Compare True signal. This output is high when the

current count is less than (or less than or equal to) the value in Data Register 2 (compare type controlled by Mode[1] in the PSoC block Function Register). The auxiliary output can be routed via Global Output lines. The PSoC block Output Register (DBA000OU-DCA070U) controls output options.

9.5.1.5 Interrupts

Interrupts may be generated in either of two ways. First, the PSoC block may optionally generate an interrupt on the rising edge of Terminal Count or the rising edge of the Compare True signal. The selection of interrupt source is determined by the MODE[0] bit of the PSoC block Function Register (DBA00FN-DCA07FN). The MODE[1] bit controls whether the comparison operation is “less than” or “less than or equal to.” If capture events are disabled, Data Register 2 can be used to create a periodic interrupt with a particular offset from the terminal count.

9.5.1.6 Usage Notes

1. Constraints

Hardware/software synchronous capture is only available with a clocking rate of 24 MHz and below.

2. Software Capture

When a capture event occurs, all bytes in a multi-byte timer transfer simultaneously from the current count (Data Register 0) to the capture register (Data Register 2). To generate a software capture event, only the least significant Data Register 0 byte needs to be read by the CPU. This causes the same simultaneous transfer as a hardware event.

3. Disabled State

When the Control Register Enable bit is set to '0', the internal block clock is turned off. A write to Data Register 1 (Period) is loaded directly into Data Register 0 (Counter) to initialize or reset the count. All outputs are low and the block interrupt is held low. Disabling a timer does not affect the current count value and it may be read by the CPU. However, since hardware/software capture is disabled in this state, two reads are required to read each byte of a multi-byte register. One to transfer each Data Register 0 count value to the associated Data Register 2 capture register, then one to read the result in Data Register 2.

4. Capture vs. Compare

A capture event will overwrite Data Register 2. This is also the register that holds the compare value. Therefore, using the capture function may not be compatible with using the timer compare function.

9.5.2 Counter with Optional Compare (Pulse-Width) Output

9.5.2.1 Summary

Conceptually, a counter measures the number of events between “ticks,” however, this distinction between counter and timer blurs because both functions provide a complete range of clock selections. The counter trades the timer’s hardware capture for a clock gate or “enable” and provides a means of adjusting the duty cycle of its output so that it can double as a pulse-width modulator. A down counter lies at the heart of the counter function. Counter-configured PSoC blocks may be chained to arbitrary lengths in 8 bit increments.

In a Counter User Module, the data input is an enable for counting. Normally, when the enable goes low, the counter will hold the current count. However, if the enable happens to go low in the same clock period as Terminal Count (count of all 0’s), one additional count will occur that will reload the counter from the Period Register. Once the counter is reloaded from the Period Register, counting will stop.

9.5.2.2 Registers

Data Register 1 establishes the period of the counter. Data Register 0 holds the current state of the down counter. If the function is disabled, writing a period into Data Register 1, will automatically load Data Register 0. It is also automatically reloaded on the clock cycle after it reaches zero, the terminal count value. The value in Data Register 2 (compare value) is continually compared to Data Register 0 (count value) to establish the output pulse-width (duty cycle). Reading Data Register 0 to obtain the current value of the down counter may occur only when the function is disabled. When read, this transfers the value from Data Register 0 to Data Register 2 and returns a 0 on the data bus. The value transferred to Data Register 2 can then be directly read by the CPU. However, reading the count value in this manner will overwrite any previously written compare value in Data

Register 2. Control Register 0 contains one bit to enable/disable the function.

9.5.2.3 Inputs

There are two primary inputs, the Source Clock and the Enable signal. When the Enable signal is high, the down counter is decremented on the rising-edge of the Source Clock. The multiplexers selecting these inputs are controlled by the PSoC block Input Register (DBA00IN-DCA07IN).

9.5.2.4 Outputs

The counter function drives its primary output signal, Compare True, high on the falling edge of the Source Clock when the value in Data Register 0 is less (or less than or equal to) the value in Data Register 2. The duty cycle of the pulse-width modulator formed in this way is the ratio of Data Register 2 (or Data Register 2 minus one) to Data Register 1. The choice of compare operators is determined by the MODE[1] bit. The Compare value can be routed to additional analog or digital PSoC blocks or via Global Output lines. The auxiliary output signal is the Terminal Count signal which can be routed via Global Output lines. The PSoC block Output Register (DBA00OU-DCA07OU) controls output options.

9.5.2.5 Interrupts

Interrupts may be generated in either of two ways. First, the PSoC block may optionally generate an interrupt on the rising edge of Terminal Count or the rising edge of the Compare signal. The selection of interrupt source is determined by the MODE[0] bit of the PSoC block Function Register (DBA00FN-DCA07FN). The MODE[1] bit controls whether the comparison operation is “less than” or “less than or equal to.”

9.5.2.6 Usage Notes

1. Enable Input

The enable input is synchronous and when low forces the counter into a ‘hold’ state. Outputs are unaffected by the state of the enable input. If an external source is selected as the enable input, it is synchronized to the 24 MHz clock.

2. Disabled State

When the Control Register Enable bit is set to '0', the internal block clock is turned off. A write to Data Register 1 (Period) is loaded directly into Data Register 0 (Counter) to initialize or reset the count. All outputs are low and the block interrupt is held low. Disabling a counter does not affect the current count value and it may be read by the CPU. Two reads are required to read each byte of a multi-byte register. One to transfer each Data Register 0 count value to the associated Data Register 2 capture register, then one to read the result in Data Register 2.

3. Reading the Count Value

A CPU read of Data Register 0 (count value) will overwrite Data Register 2 (compare value). Therefore, when reading the current count, a previously written compare value will be overwritten.

4. Extra Count

In a Counter User Module, the data input is an enable for counting. Normally, when the enable goes low, the counter will hold the current count. However, if the enable happens to go low in the same clock period as Terminal Count (count of all 0's), one additional count will occur that will reload the counter from the Period Register. Once the counter is reloaded from the Period Register, counting will stop.

9.5.3 Deadband Generator

9.5.3.1 Summary

The Deadband function produces two output waveforms, F0 and F1, with the same frequency as the input, but "under-lapped" so they are never both high at the same time. An 8-bit down counter controls the length of the "dead time" during which both output signals are low. When the deadband function detects a rising edge on the input waveform, the F1 output signal goes low and the counter decrements from its initial value to its terminal count. When the down counter reaches zero, the F0 output signal goes high. The process reverses on the falling edge of the input waveform so that after the same dead time, F1 goes high until the input signal transitions again. Dead-band generator PSoC blocks cannot be chained to increase the width of the down counter beyond 8 bits or 256 dead-time "ticks."

9.5.3.2 Registers

Data Register 1 stores the count that controls the elapsed dead time. Data Register 0 holds the current state of the dead-time down counter. If the function is disabled, writing a period into Data Register 1, will automatically load Data Register 0 with the deadband period. This period is automatically re-loaded into the counter on each edge of the input signal. Data Register 2 is unused. Control Register 0 contains one bit to enable/disable the function.

9.5.3.3 Inputs

The input controls the period and duty cycle of the dead-band generator outputs. This input is fixed to be derived from the primary output of the previous block. If this signal is pulse-width modulated, i.e., if a PWM block is configured as the previous block, the dead-band outputs will be similarly modulated. The F0 output corresponds to the duty cycle of the input (less the dead time) and F1 to the duty cycle of the inverted input (again, less the dead time). The clock input to the dead-band generator controls the rate at which the down counter is decremented. The primary data input is the "Kill" Signal. When this signal is asserted high, both F0 and F1 outputs will go low. The multiplexers selecting these input are controlled by the PSoC block Input Register (DBA00IN-DCA07IN).

9.5.3.4 Outputs

Both the F0 and F1 outputs can be driven onto the Global Output bus. If the next PSoC block selects "Previous PSoC block" for its clock input, it only "sees" the F0 output of the dead-band function. The PSoC block Output Register (DBA00OU-DCA07OU) controls output options.

9.5.3.5 Interrupts

The rising edge of the F0 signal provides the interrupt for this block.

9.5.3.6 Usage Notes

1. Constraints

The dead time must not exceed the minimum of the input signal's pulse-width high and pulse-width low time, less two CPU clocks. Dead time equals the period of the input clock times one plus the value written to Data Register 1.

2. Enabling

The data input to the Dead-Band function is hardware to the primary output of the previous block, which is typically programmed to be a PWM. The proper order for enabling these blocks (writing the Control Register 0) is PWM first, then Dead-Band.

3. Disabled State

When the Control Register Enable bit is set to '0', the internal block clock is turned off. A write to Data Register 1 (Period) is loaded directly into Data Register 0 (Counter) to initialize or reset the dead-band time. All outputs are low and the block interrupt is held low.

4. Asserting the Kill Signal

When the Kill signal is asserted high, both outputs FO and F1 are held low. When the Kill signal is selected from an external source through a Global Input, it is synchronized to the 24 MHz clock and therefore has up to 42 ns of latency.

5. Negating the Kill Signal

The Kill signal may be negated at any time. However, the output may be enabled at an arbitrary time with respect to the F0 and F1 generation. If exact timing is required when re-enabling the F0 and F1 outputs, the following procedure is recommended:

1. Kill is asserted.
2. Write to Control Register 0 to disable the block.
3. Write to Data Register 1 (Deadband time) to initialize the period.
4. Kill is eventually negated.
5. Write to Control Register 0 to enable the block.

9.5.4 PRS - Pseudo-Random Sequence Generator

9.5.4.1 Summary

The PRS function generates an output waveform corresponding to a sequence of pseudo-random numbers. A linear-feedback shift register generates the sequence according to a user-specified polynomial. The width of the numbers in the sequence is variable and the initial value is determined by a user-defined "seed" value. PRS

PSoC blocks can be chained to increase the width of the numbers and, hence, the length of the sequence. A chain of N PSoC blocks can generate numbers from 2- to 8N-bits wide and sequences of up to $2^{8N}-1$ distinct values.

9.5.4.2 Registers

Data Register 0 implements a linear-feedback shift register. Data Register 2 holds the "seed" value and when the block is disabled, a write to Data Register 2 is loaded directly into Data Register 0 (The block must be disabled when writing this value). Data Register 1 specifies the polynomial and width of the numbers in the sequence (see 9.5.4.6).

9.5.4.3 Inputs

The clock input determines the rate at which the output sequence is produced. The data input must be set to low for the block to function as a PRS. The multiplexer for selecting these inputs is controlled by the PSoC block Input Register (DBA00IN-DCA07IN).

9.5.4.4 Outputs

The PRS function drives the output serial data stream synchronous with the input clock. The output bits change on the rising edge of the input clock. The output may be driven on the Global Output bus or to the subsequent digital PSoC block. The PSoC block Output Register (DBA00OU-DCA07OU) controls output options.

9.5.4.5 Interrupts

The PRS function provides an interrupt based on the Compare signal between Data Register 0 and Data Register 2. Data Register 2 is initially loaded with the "seed" value, and therefore a periodic interrupt will be generated when the PRS count matches the seed value.

9.5.4.6 Determining the Polynomial

A simple linear-feedback shift register, or LFSR, uses an XOR gate to “add” the values of one or more bits and feed the result back into the least-significant bit. One possible realization of a 6-bit LFSR providing a maximal sequence of 63 six-bit values is shown here:

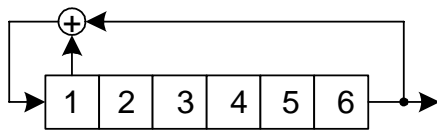

Figure 13: Polynomial LFSR

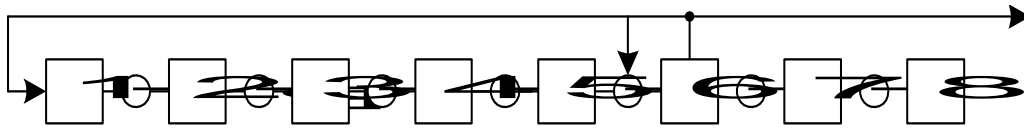

Figure 14: Polynomial PRS

Denote the first implementation as a (6, 1) LFSR, where 6 gives the length of the output codes and 1 indicates the tap which feeds the XOR gate along with the final bit. Then the modular form just shown is denoted as a [6, 5] LFSR. In general, the equivalent modular form of a simple N bit LFSR with M taps denoted by $(N, t_1, t_2, \dots, t_M)$ is given by the notation $[N, N-t_1, N-t_2, \dots, N-t_M]$. Once the form (and thus the notation) is determined, the value of Data Register 1 is easily determined. The bit corresponding to the length and all tap bits are turned on; the others are zero. Thus, the polynomial specification for Data Register 1 to implement a [6, 5] LFSR is 00110000b, or 30h. A maximal sequence PRS for 8-bits giving 255 codes is [8, 4, 3, 2] with polynomial 10001110b or 8Eh.

9.5.4.7 Usage Notes

1. Disabled State

When the Control Register Enable bit is set to ‘0’, the internal block clock is turned off. A write to Data Register 2 (Seed) is loaded directly into Data Register 0 (LFSR) to initialize or reset the seed value. All outputs are low and the block interrupt is held low.

2. Reading the LFSR

The PRS function utilizes a different “modular” architecture with one XOR gate between each bit of the shift register. A maximal sequence equivalent to that produced by the previous realization is generated by the following modular LFSR

The current LFSR value can only be read when the block is disabled by setting the Control Register bit 0 to low. Each byte of the current LFSR value (in the case of a multi-byte block) must be read individually. The Data Register 0 byte (LFSR), which returns 0, then the Data Register 1 byte, which returns the actual value.

9.5.5 CRC - Cyclic Redundancy Check

9.5.5.1 Summary

The CRC uses a shift register and XOR gates like the PRS function. However, instead of an output bit stream, the CRC function expects an input bit stream. Functionally the CRC block is identical to the PRS with the exception of the selected input data. Input data must be presented synchronously to the clock. A polynomial specification permits the length of the input sequence over which the cyclic redundancy check computes a result to be varied. CRC-configured PSoC blocks can be chained to form longer results.

9.5.5.2 Registers

Data Register 0 implements a linear-feedback shift register. Data Register 2 holds the “seed” value and when the block is disabled, a write to Data Register 2 is loaded

directly into Data Register 0 (The block must be disabled when writing this value). Data Register 1 specifies the polynomial and width of the numbers in the sequence (see “Specifying the Polynomial”, below). Once the input bit stream is complete, the result may be read by first reading Data Register 0, which returns 0, then reading Data Register 2, which returns the actual result.

9.5.5.3 Inputs

The clock input determines the rate at which the input sequence is processed. The data input selects the data stream to process. It is assumed that the data is valid on the positive edge of the clock input. The multiplexer for selecting these inputs is controlled by the PSoC block Input Register (DBA00IN-DCA07IN).

9.5.5.4 Outputs

Like the PRS, the CRC function drives the output serial data stream with the most significant bit of CRC processing synchronous with the input clock. Normally the CRC output is not used. The output may be driven on the Global Output bus or to the subsequent digital PSoC block. The PSoC block Output Register (DBA00OU-DCA07OU) controls output options.

9.5.5.5 Interrupts

The CRC function provides an interrupt based on the Compare signal between Data Register 0 and Data Register 2.

9.5.5.6 Specifying the Polynomial

Computation of an N-bit result is generally specified by a polynomial with N+1 terms, the last of which is the X^0 term, where $X^0=1$. For example, the widely used CRC-CCIT 16-bit polynomial is $X^{16}+X^{12}+X^5+1$. The PSoC block CRC function assumes the presence of the X^0 term so that the polynomial for an N-bit result can be expressed by an N-bit rather than N+1 bit specification. To obtain the PSoC block register specification, write an N+1 bit binary number corresponding to the full polynomial, with 1's for each term present. The CRC-CCIT polynomial would be 10001000000100001b. Simply drop the right-most bit (the X^0 term) to obtain the register specification for the PSoC block. To implement the CRC-

CCIT example, two PSoC blocks must be chained together. Data Register 1 in the high-order PSoC block would take the value 10001000b (88h) and the corresponding register in the low-order PSoC block would take 00010000b (10h).

9.5.5.7 Usage Notes

1. Disabled State

When the Control Register Enable bit is set to '0', the internal block clock is turned off. A write to Data Register 2 (Seed) is loaded directly into Data Register 0 (LFSR) to initialize or reset the seed value. All outputs are low and the block interrupt is held low.

2. Reading the CRC value

After the data stream has been processed by the LFSR, the residue is the CRC value. The current LFSR value can only be read when the block is disabled by setting the Control Register bit 0 to low. Each byte of the current LFSR value (in the case of a multi-byte block) must be read individually. The Data Register 0 byte (LFSR) must be read, which returns 0, then the Data Register 2 byte, which returns the actual value.

9.5.6 Universal Asynchronous Receiver

9.5.6.1 Summary

The Universal Asynchronous Receiver implements the input half of a basic 8-bit UART. Start and Stop bits are recognized and stripped. Parity type and parity validation are configurable features. This function requires a Digital Communications Type PSoC block and cannot be chained for longer data words.

9.5.6.2 Registers

The function shifts incoming data into Data Register 0. Once complete, the byte is transferred to Data Register 2 from which it may be read. Data Register 2 acts as a 1 byte receive buffer. Data Register 1 is not used by this function. Control Register 0 (DCA04CR0-DCA07CR0) enables the function, provides the means to configure parity checking, and a full set of status indications. See the register definition for full details.

9.5.6.3 Inputs

A baud-rate clock running at 8 times the desired input bit rate is selected by the clock-input multiplexer. The serial data input and clock input are controlled by the Input Register (DCA04IN-DCA07IN).

9.5.6.4 Outputs

None.

9.5.6.5 Interrupts

The function can be configured to generate an interrupt on RXREGFULL (Receive Register Full) status (Data Register 2 is full).

9.5.6.6 Usage Notes

1. Reading the Status

Reading Control Register 0, which contains the status bits, automatically resets all status bits to 0 with the exception of RX Reg Full. Reading Data Register 2 (Receive Data Register) clears the RX Reg Full status.

2. Using Interrupts

RX Reg Full status generates an interrupt but the Receive Data Register (Data Register 2) must be read to clear the RX Reg Full status. If this registers is not read in the interrupt routine, the status will not be cleared and further interrupts will be suppressed.

If the stop bit in a transmitted byte is missing, the receiver will declare a framing error. Once this occurs, this missing stop bit can be interpreted as the start bit of the next byte, which will produce another framing error.

9.5.7 Universal Asynchronous Transmitter

9.5.7.1 Summary

The Universal Asynchronous Transmitter implements the output half of a basic 8-bit UART. Start and Stop bits are generated. Parity bit generation and type are configurable features. This function requires a Digital Communications Type PSoC block. It cannot be chained for longer data words.

9.5.7.2 Registers

When Data Register 0 is empty and a new byte has been written to Data Register 1, the function transfers the byte to Data Register 0 and shifts it out along with a start bit, optionally a parity bit and a stop bit. Once Data Register 0 is loaded with the byte to shift out, Data Register 0 can be immediately loaded with the next byte to transmit, acting as a 1 byte transmit buffer. Data Register 2 is not used by this function. The PSoC block's Control Register 0 (DCA04CR0-DCA07CR0) configures the parity type and enable. It also provides status information to enable detection of transmission complete.

9.5.7.3 Inputs

A baud-rate clock running at 8 times the desired output bit rate is selected by the clock-input multiplexer controlled by the PSoC block Input Register (DCA04IN-DCA07IN). The Data Input multiplexer is ignored by this function.

9.5.7.4 Outputs

The transmitter's serial data output appears at the PSoC block output and may be driven onto one of the Global Output bus lines. The PSoC block Output Register (DCA04OU-DCA07OU) controls output options.

9.5.7.5 Interrupts

If enabled, the function will generate an interrupt when the TX Reg Empty status is set (Data Register 1 is empty). Optionally, the interrupt can be set to TX Complete status, which indicates all bits of a given byte have been sent, including framing bits. This option is selected based on the Mode[1] bit in the Function Register.

9.5.7.6 Usage Notes

1. TX Reg Empty Interrupt

An initial byte must be written to the TX Data Register (Data Register 1) to enable subsequent TX Reg Empty status interrupts. This does not apply if the TX Complete interrupt source is selected.

2. Reading the Status

Reading Control Register 0, which contains the status bits, automatically resets the status bits to 0,

except for TX Reg Empty. TX Reg Empty is automatically cleared when a byte is written to the TX Data Register (Data Register 1).

3. Using CPU Interrupts

TX Reg Empty status or optionally TX Complete status generates the block interrupt. Executing the interrupt routine does not automatically clear status. If TX Complete is selected as the interrupt source, Control Register 0 (status) must be read in the interrupt routine to clear the status. If TX Reg Empty is selected, a byte must be written to the TX Data Register (Data Register 1) to clear the status. If the status is not cleared, further interrupts will be suppressed.

9.5.8 SPI Master - Serial Peripheral Interface (SPIM)

9.5.8.1 Summary

The SPI Master function provides a full-duplex synchronous data transceiver that also generates a bit clock for the data. This function requires a Digital Communications Type PSoC block. It cannot be chained for longer data words. This Digital Communications Type PSoC block supports SPI modes for 0, 1, 2, and 3. See [Figure 15](#): for waveforms of the Clock Phase modes.

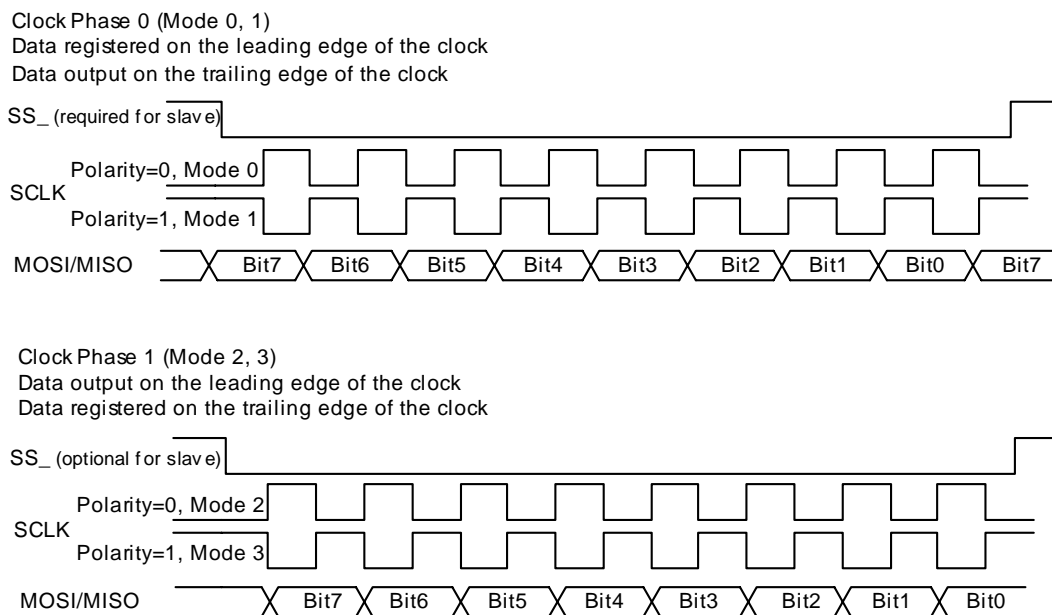

Figure 15: SPI Waveforms

9.5.8.2 Registers

Data Register 0 provides a shift register for both incoming and outgoing data. Output data is written to Data Register 1 (TX Data Register). When this block is idle, a write to the TX Data Register will initiate a transmission. Input data is read from Data Register 2 (RX Data Register). When Data Register 0 is empty, its value is updated from Data Register 1, if new data is available. As data bits are shifted in, the transmit bits are shifted out. After the 8 bits are transmitted and received by Data Register

0, the received byte is transferred into Data Register 2 from where it can be read. Simultaneously, the next byte to transmit, if available, is transferred from Data Register 1 into Data Register 0. Control Register 0 (DCA04CR0-DCA07CR0) provides status information and configures the function for one of the four standard modes, which configure the interface based on clock polarity and phase with respect to data.

If the SPI Master block is being used to receive data, “dummy” bytes must be written to the TX Data Register in order to initiate transmission/reception of each byte.

9.5.8.3 Inputs

MISO (master-in, slave-out) is selected by the input multiplexer. The clock input multiplexer selects a clock that runs at twice the desired data rate. The SPIM function divides the input clock by 2 to obtain the 50% duty-cycle required for proper timing. The input multiplexer is controlled by the PSoC block Input Register (DCA04IN-DCA07IN).

9.5.8.4 Outputs

There are two outputs, both of which can be enabled onto the Global Output bus. The MOSI (master-out, slave-in) data line provides the output serial data. The second output is the bit-clock derived by dividing the input clock by 2 to ensure a 50% duty-cycle. The PSoC block Output Register (DCA04OU-DCA07OU) controls output options.

Note: The SPIM function does not provide the SS_ signal that may be used by a corresponding SPI Slave. However, this can be implemented with a GPIO pin and supporting firmware if desired.

9.5.8.5 Interrupts

When enabled, the function generates an interrupt on TX Reg Empty status (Data Register 1 empty). If Mode[1] in the Function Register is set, the SPI Master will generate an interrupt on SPI Complete.

9.5.8.6 Usage Notes

1. Reading the Status

Reading Control Register 0, which contains the status bits, automatically resets the status bits to 0 with the exception of TX Reg Empty, which is cleared when a byte is written to the TX Data Register (Data Register 1), and the RX Reg Full, which is cleared when a byte is read from the RX Data Register (Data Register 2).

2. Using Interrupts

TX Reg Empty status or optionally SPI Complete status generates the block interrupt. Executing the

interrupt routine does not automatically clear status. If SPI Complete is selected as the interrupt source, Control Register 0 (status) must be read in the interrupt routine to clear the status. If TX Reg Empty status is selected, a byte must be written to the TX Data Register (Data Register 1) to clear the status. If the interrupting status is not cleared further interrupts will be suppressed.

9.5.9 SPI Slave - Serial Peripheral Interface (SPIS)

9.5.9.1 Summary

The SPI Slave function provides a full-duplex bi-directional synchronous data transceiver that requires an externally provided bit clock for the data. This function requires a Digital Communications Type PSoC block. It cannot be chained for longer data words. This Digital Communications Type PSoC block supports SPI modes for 0, 1, 2, and 3. See [Figure 15](#): for waveforms of the supported modes.

9.5.9.2 Registers

Data Register 0 provides a shift register for both incoming and outgoing data. Output data is written to Data Register 1 (TX Data Register). Input data is read from Data Register 2 (RX Data Register). When Data Register 0 is empty, its value is updated from Data Register 1. As new data bits are shifted in, the transmit bits are shifted out. After the 8 bits are transmitted and received by Data Register 0, the received byte is transferred into Data Register 2 from which it can be read. Simultaneously, the next byte to transmit, if available, is transferred from Data Register 1 into Data Register 0. Control Register 0 (DCA04CR0-DCA07CR0) provides status information and configures the function for one of the four standard modes, which configure the interface based on clock polarity and phase with respect to data.

9.5.9.3 Inputs

The SPIS function has three inputs. The Input Register (DCA04IN-DCA07IN) controls the input multiplexer, which selects the MOSI data stream. It also controls the clock selection multiplexer from which the function obtains the master’s bit clock. The AUX-IO bits of the Output Register (DCA04OU-DCA07OU) select a Global Input signal from which the SS_ (Slave Select) signal is obtained. It is important to note that the SS_ signal can

only be input from GPIO input pins (Global Input Bus). There is no way to enable the SS_ internally. In SPI modes 2 & 3, where SS is not required between each byte, the external pin may be grounded.

Important: The AUX Out Enable bit (bit 5) of the Output Register (DCA04OU-DCA07OU) must be set to 0 to disable it.

9.5.9.4 Outputs

The function output is the MISO (master-in, slave-out) signal, which may be driven on the Global Output bus and is selected by Output Register (DCA04OU-DCA07OU).

9.5.9.5 Interrupts

When enabled, the function generates an interrupt on RX Reg Full status (Data Register 2 full). If Mode[1] of the Function Register is set, the interrupt will be generated on SPI Complete status.

9.5.9.6 Usage Notes

1. Reading the Status

Reading Control Register 0, which contains the status bits, automatically resets the status bits to 0 with the exception of TX Reg Empty, which is cleared when a byte is written to the TX Data Register (Data Register 1), and the RX Reg Full, which is cleared when a byte is read from the RX Data Register (Data Register 2).

2. Multi-Slave Environment

The SS_ signal does not have any affect on the output from the slave. The output of the slave at the end of a reception/transmission is always the first bit sent (the MSB, unless LSBF option is selected, then it's the LSB). To implement a multi-slave environment, a GPIO interrupt may be configured on the SS_ input, and the Slave output strength may be toggled between driving and High Z in firmware.

3. Using Interrupts

RX Reg Full status or SPI Complete status generates an interrupt. Executing the interrupt routine does not automatically clear status. If SPI Complete is selected as the interrupt source, Control Register 0 (status) must be read in the interrupt routine to clear the status. If RX Reg Full status is selected, a byte must be read from the RX Data Register (Data

Register 2) to clear the status. If the interrupting status is not cleared further interrupts will be suppressed.

4. Synchronization of CPU Interaction

Because the SPI Slave is clocked asynchronously by the master SCLK, transfer of data between the TX Register to shifter and shifter to RX Register occurs asynchronously.

Either polling or interrupts can be used to detect that a byte has been received and is ready to read. However, on the TX side, the user is responsible for implementing a protocol that ensures there is enough set-up time from the TX Data Register write to the first clock (mode 2, 3) or SS_ (mode 0, 1) from the master.

10.0 Analog PSoC Blocks

10.1 Introduction

PSoC blocks are user configurable system resources. On-chip analog PSoC blocks reduce the need for many MCU part types and external peripheral components. Analog PSoC blocks can be configured to provide a wide variety of peripheral functions. PSoC Designer Software Integrated Development Environment provides automated configuration of PSoC blocks by simply selecting the desired functions. PSoC Designer then generates the proper configuration information and can print a device data sheet unique to that configuration.

Each of the analog blocks has many potential inputs and several outputs. The inputs to these blocks include analog signals from external sources, intrinsic analog signals driven from neighboring analog blocks or various voltage reference sources.

There are three discrete outputs from each analog block (there are an additional two discrete outputs in the Continuous Time blocks), 1) the analog output bus (ABUS), which is an analog bus resource that is shared by all of the analog blocks in a column, 2) the comparator bus (CBUS), which is a digital bus resource that is shared by all of the analog blocks in a column, and 3) the output bus (OUT, (plus GOUT and LOUT in the Continuous Time blocks)), which is an analog bus resource that is shared by all of the analog blocks in a column and connects to one of the analog output buffers, to send a signal externally to the device. There are also intrinsic outputs that connect to neighboring analog blocks.

Twelve analog PSoC blocks are available separately or combined with the digital PSoC blocks. A precision internal voltage reference provides accurate analog comparisons. A temperature sensor input is provided to the analog PSoC block array supporting applications like battery chargers and data acquisition without requiring external components.

There are three analog PSoC block types: Continuous Time (CT) blocks, and Type A and Type B Switch Capacitor (SC) blocks. CT blocks provide continuous time analog functions. SC blocks provide ADC and DAC analog functions. Currently, supported analog functions are 12-

bit Incremental and 11-bit Delta-Sigma ADC, successive approximation ADCs up to 6 bits, DACs up to 8 bits, programmable gain stages, sample and hold circuits, programmable filters, comparators, and a temperature sensor.

The analog functionality provided is as follows:

- A/D and D/A converters, programmable gain blocks, comparators, and switched capacitor filters.
- Single ended configuration is cost effective for reasonable speed / accuracy, and provides simple interface to most real-world analog inputs and outputs.
- Support is provided for sensor interfaces, audio codes, embedded modems, and general-purpose op amp circuits.
- Flexible, System on-a-Chip programmability, providing variations in functions.
- For a given function, easily selected trade-offs of accuracy and resolution with speed, resources (number of analog blocks), and power dissipated for that application.
- The analog section is an "Analog Computation Unit," providing programmed steering of signal flow and selecting functionality through register-based control of analog switches. It also sets coefficients in Switched Capacitor Filters and noise shaping (Delta-Sigma) modulators, as well as programs gain or attenuation settings in amplifier configurations.
- The architecture provides continuous time blocks and discrete time (Switched Capacitor) blocks. The continuous time blocks allow selection of precision amplifier or comparator circuitry using programmable resistors as passive configuration and parameter setting elements. The Switched Capacitor (SC) blocks allow configuration of DACs, Delta Sigma, incremental or Successive Approximation ADCs, or Switched Capacitor filters with programmable coefficients.

10.2 Analog System Clocking Signals

Table 61: Analog System Clocking Signals

Signal	Definition
ACLK0	A system-clocking signal that is driven by the clock output of a digital PSoC block and can be selected by the user to drive the clocking signal to an analog column. Any of the 8 digital PSoC blocks can be muxed into this line using the ACLK0[2:0] bits in the Analog Clock Select Register (CLK_CR1).
ACLK1	A system-clocking signal that is driven by the clock output of a digital PSoC block and can be selected by the user to drive the clocking signal to an analog column. Any of the 8 digital PSoC blocks can be muxed into this line using the ACLK1[2:0] bits in the Analog Clock Select Register (CLK_CR1).
Acolumn0	A system-clocking signal that can drive all analog PSoC blocks in Analog Column 0. This signal is derived from the muxed input of the 24V1 , 24V2 , ACLK0 , and ACLK1 system clock signals. The output of this mux is then passed through a 1:4 divider to reduce the frequency by a factor of 4. The Acolumn0[1:0] bits in the CLK_CR0 Register determine the selected Column Clock.
Acolumn1	A system-clocking signal that can drive all analog PSoC blocks in Analog Column 1. This signal is derived from the muxed input of the 24V1 , 24V2 , ACLK0 , and ACLK1 system clock signals. The output of this mux is then passed through a 1:4 divider to reduce the frequency by a factor of 4. The Acolumn1[1:0] bits in the CLK_CR0 Register determine the selected Column Clock.
Acolumn2	A system-clocking signal that can drive all analog PSoC blocks in Analog Column 2. This signal is derived from the muxed input of the 24V1 , 24V2 , ACLK0 , and ACLK1 system clock signals. The output of this mux is then passed through a 1:4 divider to reduce the frequency by a factor of 4. The Acolumn2[1:0] bits in the CLK_CR0 Register determine the selected Column Clock.
Acolumn3	A system-clocking signal that can drive all analog PSoC blocks in Analog Column 3. This signal is derived from the muxed input of the 24V1 , 24V2 , ACLK0 , and ACLK1 system clock signals. The output of this mux is then passed through a 1:4 divider to reduce the frequency by a factor of 4. The Acolumn3[1:0] bits in the CLK_CR0 Register determine the selected Column Clock.

10.3 Array of Analog PSoC Blocks

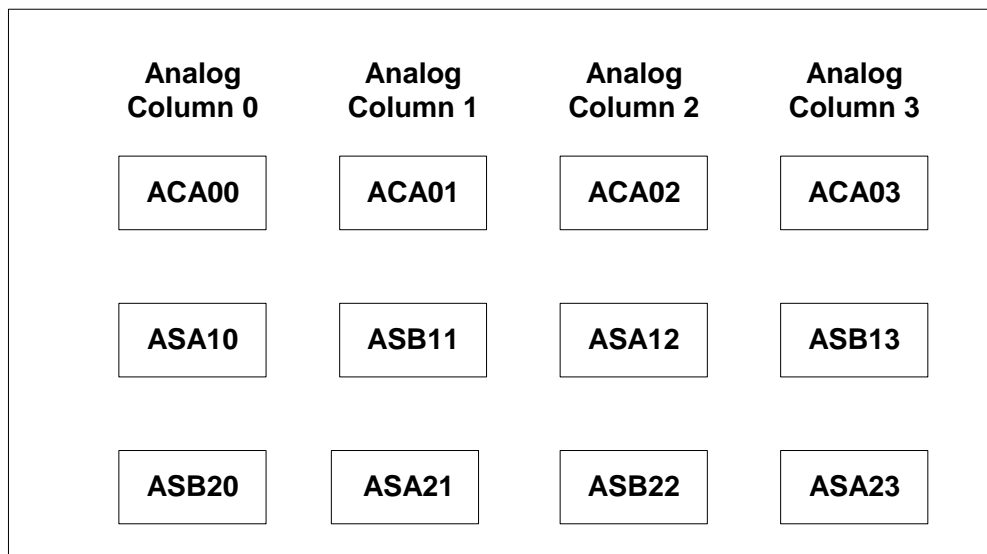

Figure 16: Array of Analog PSoC Blocks

10.4 Analog Reference Control

The reference generator establishes a set of three internally fixed reference voltages for the whole chip, AGND, RefHi and RefLo. The 8C26xxx is a single supply part, with no negative voltage available or applicable. Analog ground (AGND) is constructed near mid-supply. This ground is routed to all analog blocks and separately buffered within each block. There may be a small offset volt-

age between buffered analog grounds, as indicated in the AC/DC Characteristics section. RefHi and RefLo signals are generated, buffered and routed to the analog blocks. RefHi is used to set the conversion range (i.e., span) of analog to digital (ADC) and digital to analog (DAC) converters. RefHi and RefLo can be used to set thresholds in comparators.

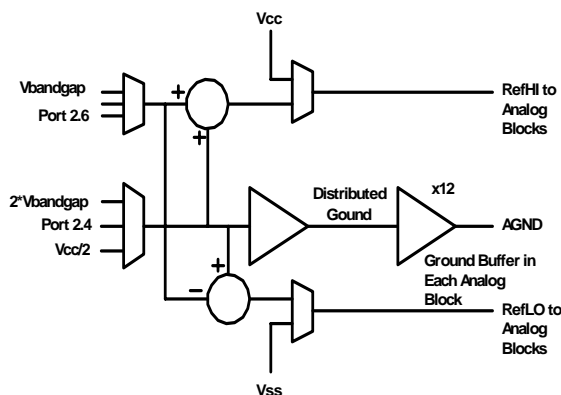

Figure 17: Analog Reference Control Schematic

10.4.1 Bandgap Test

BGT Bandgap Test is used for factory testing of the internal reference voltage testing.

10.4.2 Bias Level

HBE Controls the bias level for all analog functions. It operates with the power setting in each block to set the parameters of that block. Most applications will benefit most from the low bias level. At high bias, the analog block op-amps have faster slew rate but slightly less voltage swing and higher noise.

10.4.3 AGND, RefHI, RefLO

REF Sets Analog Array Reference Control, selecting specific combinations of voltage for analog ground and references. Many of these reference voltages are based on the precision internal reference, a Silicon band gap operating at 1.300 Volts. This reference has good thermal stability and power supply rejection.

Alternatively, the power supply can be scaled to provide analog ground and references; this is particularly useful for signals, which are ratiometric to the power supply voltage.

User supplied external precision references can be connected to Port 2 inputs (available on 28 pin and larger parts). This is useful in setting reference for specific customer applications such as a +/-1.000 V (from AGND) ADC scale. References derived from Port 2 inputs are limited to the same output voltage range as the op-amps in the analog blocks.

Table 62: AGND, RefHI, RefLO Operating Parameters

	AGND		RefHI		RefLO		Notes
	Source	Voltage	Source	Voltage	Source	Voltage	
000	$V_{cc}/2$	2.5 V 1.65 V	$V_{cc}+V_{bg}$	3.8 V 2.95 V	$V_{cc}-V_{bg}$	1.2 V 0.35 V	5.0 V System 3.3 V System
001	P2[4]	2.2 V ¹	P2[4]+P2[6]	3.2 V ¹	P2[4]-P2[6]	1.2 V ¹	User Adjustable
010	$V_{cc}/2$	2.5 V 1.65 V	V_{cc}	5.0 V 3.3 V	V_{ss}	0.0 V 0.0 V	5.0 V System 3.3 V System
011	2* V_{bg}	2.6 V	2* $V_{bg}+V_{bg}$	3.9 V	2* $V_{bg}-V_{bg}$	1.3 V	Not for 3.3 V Systems
100	2* V_{bg}	2.6 V	2* $V_{bg}+P2[6]$	3.6 V ¹	2* $V_{bg}-P2[6]$	1.6 V ¹	Not for 3.3 V Systems
101	P2[4]	2.2 V ¹	P2[4]+ V_{bg}	3.5 V ¹	P2[4]- V_{bg}	0.9 V ¹	User Adjustable
110	Reserved						
111	Reserved						

1. Example shown for AGND P2[4] = 2.2 V and Ref P2[6] = 1.0 V

10.4.4 Analog Array Power Control

PWR Sets Analog Array Power Control. Analog array power is controlled through the bias circuits in the Continuous Time blocks and separate bias circuits in the Switched Capacitor blocks. Continuous Time blocks (ACAxx) can be operated to make low power comparators independent of Switched Capacitor (ASAxx and ASBxx) blocks, without their power consumption.

The reference array supplies voltage to all blocks and current to the Switched Capacitor blocks. At higher block clock rates, there is increased reference current demand; the reference power should be set equal to the highest power level of the analog blocks used.

Table 63: Analog Reference Control Register

Bit #	7	6	5	4	3	2	1	0
POR	0	0	0	0	0	0	0	0
Read/Write	RW	RW	RW	RW	RW	RW	RW	RW
Bit Name	BGT	HBE	REF[2]	REF[1]	REF[0]	PWR[2]	PWR[1]	PWR[0]

Bit 7: BGT Bandgap Test used for internal reference voltage testing (customer should not alter; must be written as 0)

Bit 6: HBE Bias level control for op-amps

0 = Low bias mode for analog array

1 = High bias mode for analog array

Bit [5:3]: REF [2:0] Analog Array Reference Control

AGND **High/Low**

0 0 0 = Vcc/2 ± Bandgap

0 0 1 = P2[4] ± P2[6]

0 1 0 = Vcc/2 ± Vcc/2

0 1 1 = 2 Bandgap ± Bandgap

1 0 0 = 2 Bandgap ± P2[6]

1 0 1 = P2[4] ± Bandgap

1 1 0 = Reserved

1 1 1 = Reserved

Bit [2:0]: PWR [2:0] Analog Array Power Control

0 0 0 = All Analog Off

0 0 1 = SC Off, REFPWR Low

0 1 0 = SC Off, REFPWR Med

0 1 1 = SC Off, REFPWR High

1 0 0 = All Analog Off

1 0 1 = SC On, REFPWR Low

1 1 0 = SC On, REFPWR Med

1 1 1 = SC On, REFPWR High

Analog Reference Control Register (ARF_CR, Address = Bank 0, 63h)

10.5 Analog PSoC Block Clocking Options

All analog PSoC blocks in a particular Analog Column share the same clock signal. Choosing the clocking for an analog PSoC block is a two-step process.

1. First, if the user wants to use the **ACLK0** and **ACLK1** system-clocking signals, the digital PSoC blocks that serve as the source for these signals must be selected. This selection is made in the Analog Clock Select Register (CLK_CR1).
2. Next, the user must select the source for the **Acolumn0**, **Acolumn1**, **Acolumn2**, and **Acolumn3** system-clocking signals. The user will choose the clock for Acolumnx[1:0] bits in the Analog Column Clock Select Register (CLK_CR0). Each analog PSoC block in a particular Analog Column is clocked from the **Acolumn[x]** system-clocking signal for that column. (Note that the Acolumn[x] signals have a 1:4 divider on them.)

10.5.1 Analog Column Clock Select Register

Table 64: Analog Column Clock Select Register

Bit #	7	6	5	4	3	2	1	0
POR	0	0	0	0	0	0	0	0
Read/Write	RW	RW	RW	RW	RW	RW	RW	RW
Bit Name	Acolumn3 [1]	Acolumn3 [0]	Acolumn2 [1]	Acolumn2 [0]	Acolumn1 [1]	Acolumn1 [0]	Acolumn0 [1]	Acolumn0 [0]

Bit [7:6]: Acolumn3 [1:0]

0 0 = 24V1
 0 1 = 24V2
 1 0 = ACLK0
 1 1 = ACLK1

Bit [5:4]: Acolumn2 [1:0]

0 0 = 24V1
 0 1 = 24V2
 1 0 = ACLK0
 1 1 = ACLK1

Bit [3:2]: Acolumn1 [1:0]

0 0 = 24V1
 0 1 = 24V2
 1 0 = ACLK0
 1 1 = ACLK1

Bit [1:0]: Acolumn0 [1:0]

0 0 = 24V1
 0 1 = 24V2
 1 0 = ACLK0
 1 1 = ACLK1

Analog Column Clock Select Register (CLK_CR0, Address = Bank 1, 60h)

10.6 Analog Clock Select Register

Table 65: Analog Clock Select Register

Bit #	7	6	5	4	3	2	1	0
POR	0	0	0	0	0	0	0	0
Read/ Write	RW	RW	RW	RW	RW	RW	RW	RW
Bit Name	Reserved	SHDIS	ACLK1 [2]	ACLK1 [1]	ACLK1 [0]	ACLK0 [2]	ACLK0 [1]	ACLK0 [0]

Bit 7: Reserved

Bit 6: SHDIS During normal operation of an SC block for the amplifier of a column enabled to drive the output bus, the connection is only made for the last half of PHI2 (during PHI1 and for the first half of PHI2, the output bus floats at the last voltage to which it was driven). This forms a sample and hold operation using the output bus and its associated capacitance. This design prevents the output bus from being perturbed by the intermediate states of the SC operation (often a reset state for PHI1 and settling to the valid state during PHI2)

Following are the exceptions: 1) If the ClockPhase bit in CR0 (for the SC block in question) is set to 1, then the output is enabled for the whole of PHI2. 2) If the SHDIS signal is set in bit 6 of the Analog Clock Select Register, then sample and hold operation is disabled for all columns and all enabled outputs of SC blocks are connected to their respective output busses for the entire period of their respective PHI2s

0 = Sample and hold function enabled
1 = Sample and hold function disabled

Bit [5:3]: ACLK1 [2:0]

0 0 0 = Digital Basic Type A Block 00
0 0 1 = Digital Basic Type A Block 01
0 1 0 = Digital Basic Type A Block 02
0 1 1 = Digital Basic Type A Block 03
1 0 0 = Digital Communications Type A Block 04
1 0 1 = Digital Communications Type A Block 05
1 1 0 = Digital Communications Type A Block 06
1 1 1 = Digital Communications Type A Block 07

Bit [2:0]: ACLK0 [2:0] Same configurations as ACLK1 [2:0]

0 0 0 = Digital Basic Type A Block 00
0 0 1 = Digital Basic Type A Block 01
0 1 0 = Digital Basic Type A Block 02
0 1 1 = Digital Basic Type A Block 03
1 0 0 = Digital Communications Type A Block 04
1 0 1 = Digital Communications Type A Block 05
1 1 0 = Digital Communications Type A Block 06
1 1 1 = Digital Communications Type A Block 07

Analog Clock Select Register (CLK_CR1, Address = Bank 1, 61h)

There are a total of twelve analog PSoC blocks implemented for each of the following types; Analog Continuous Time Type A (ACAxx), Analog Switch Cap Type A (ASAxx), and Analog Switch Cap Type B (ASBxx). These blocks are arranged in an array of three rows by four columns. Each column has one of each type of PSoC block, and the individual PSoC blocks are identified by the row and column in which they reside.

There are two primary types of analog PSoC blocks. Both types contain one op-amp but their principles of operation are quite different. Continuous-time PSoC blocks employ three configuration registers and use resistors to condition amplifier response. Switched capacitor blocks have one comparator and four configuration registers and operate as discrete-time sampling operators. In both types, the configuration registers are

divided into distinct bit fields. Some bit fields set the PSoC block's resistor ratios or capacitor values. Others configure switches and multiplexers that form connections between internal block nodes. Additionally, a block may be connected via local interconnection resources to neighboring analog PSoC blocks, reference voltage sources, input multiplexers and output busses. Specific advantages and applications of each type are treated separately below.

10.6.1 Local Interconnect

Analog continuous-time PSoC blocks occupy the top row, (row 0) of the analog array. Designated ACA for analog continuous-time subtype "A," each connects to its

neighbors by means of three multiplexers. (Note that unlike the switched capacitor blocks, the continuous time blocks in the current family of parts only have one subtype.) The three are the non-inverting input multiplexer, "PMux," the inverting input multiplexer, "NMux," and the "RBotMux" which controls the node at the bottom of the resistor string. The bit fields, which control these multiplexers, are named PMux, NMux, and RBotMux, respectively. The following diagrams show how each multiplexer connects its ACA block connect to its neighbors. Each arrow points from an input source, either a PSoC block, bus or reference voltage to the block where it is used. Each arrow is labeled with the value to which the bit-field must be set to select that input source.

10.6.1.1 NMux

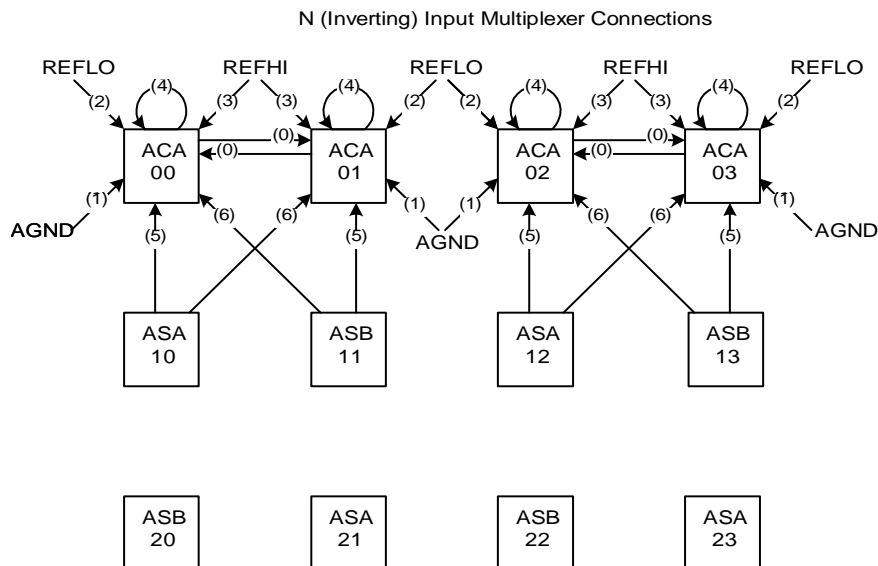

Figure 18: NMux Connections

10.6.1.2 PMux

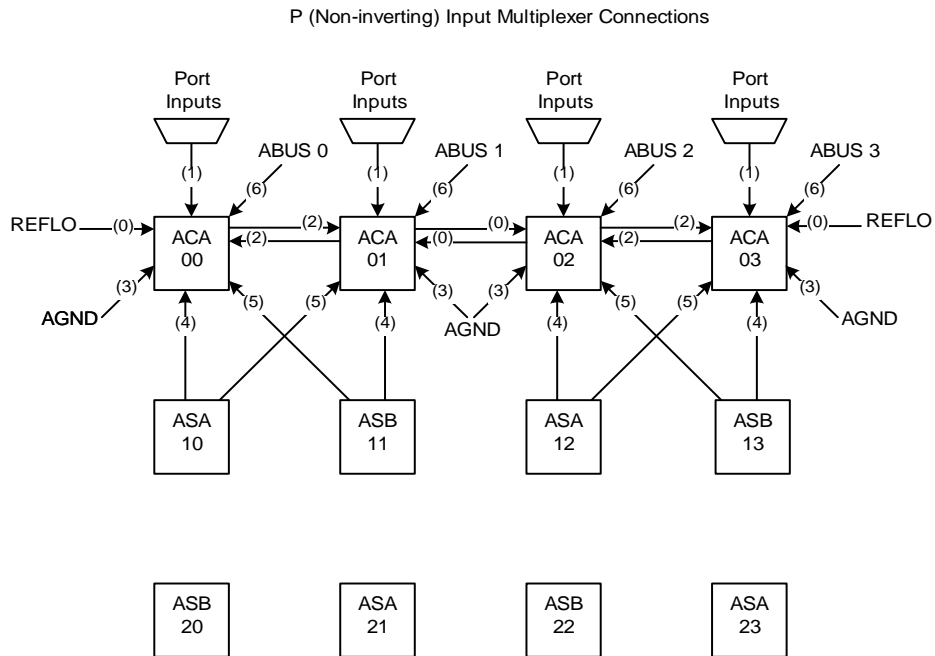

Figure 19: PMux Connections

10.6.1.3 RBotMux

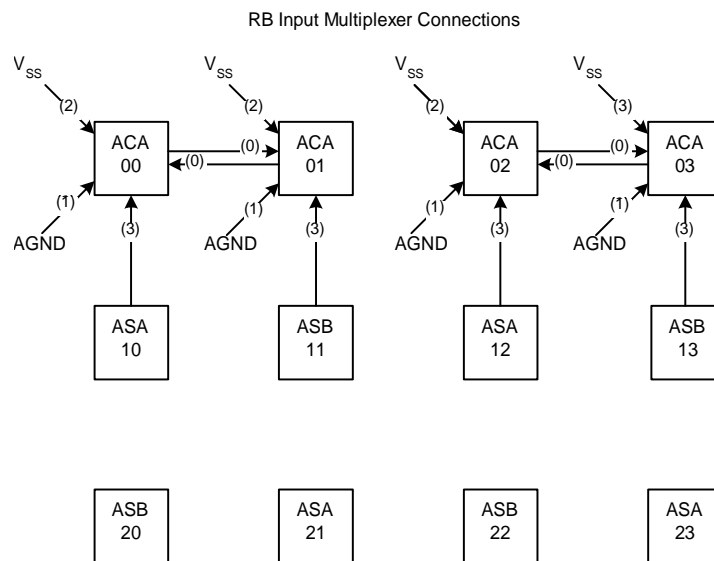

Figure 20: RBotMux Connections

10.7 Analog Continuous Time PSoC Blocks

10.7.1 Introduction

The Analog Continuous Time PSoC blocks are built around an operational amplifier. There are several analog muxes that are controlled by register-bit settings in the control registers that determine the signal topology inside the block. There is also a precision resistor matrix that is located in the feedback path for the op-amp, and is controlled by register-bit setting. There is also an analog comparator connected to the output OUT, which converts analog comparisons into digital signals.

There are five discrete outputs from this block. These outputs are:

1. The analog output bus (ABUS), which is an analog bus resource that is shared by all of the analog blocks in the analog column for that block.
2. The comparator bus (CBUS), which is a digital bus that is a resource that is shared by all of the analog blocks in a column for that block.
3. The output bus (OUT, GOUT and LOUT), which is an analog bus resource that is shared by all of the analog blocks in a column and connects to one of the analog output buffers, to send a signal externally to the device.

This block supports Programmable Gain or attenuation Op-Amp Circuits, (Differential Gain) Instrumentation Amplifiers (using two CT Blocks), Continuous time high frequency anti-aliasing filters, and modest response-time analog comparators.

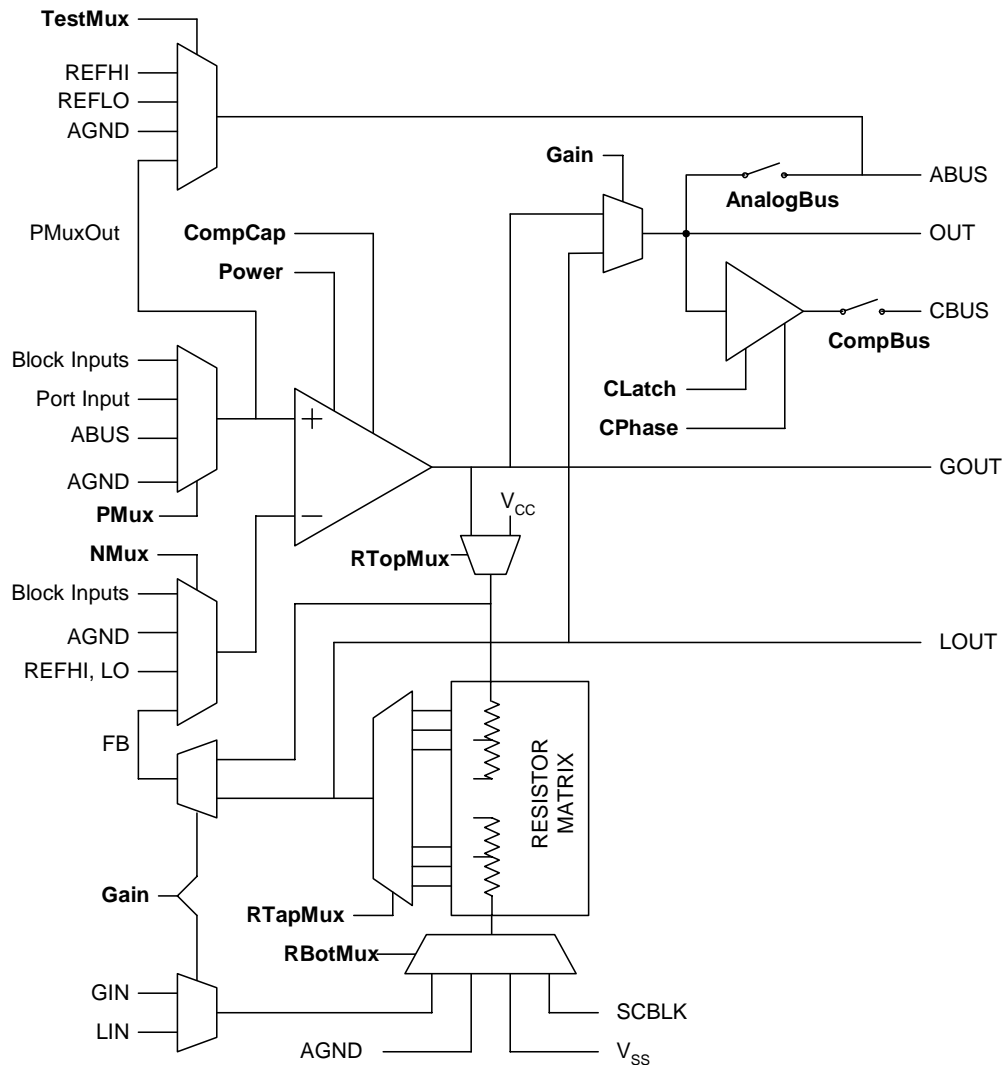

Figure 21: Analog Continuous Time PSoC Blocks

10.7.2 Registers

10.7.2.1 Analog Continuous Time Block xx Control 0 Register

The RTopMux and RBotMux bits control the connection of the two ends of the resistor string. The RTopMux bit controls the top end of the resistor string, which can either be connected to Vcc or to the op-amp output. The RBotMux bits control the connection of the bottom end of the resistor string.

The RTapMux bits control the center tap of the resistor string. Note that only relative weighting of units is given in the table.

The Gain and Loss columns correspond to the gain or loss obtained if the RTopMux and Gain bits are set so that the overall amplifier provides gain or loss.

The Gain bit controls whether the resistor string is connected around the op-amp as for gain (center tap to

inverting op-amp input) or for loss (center tap to output of the block). Note that setting Gain alone does not guarantee a gain or loss block. Routing of the other ends of the resistor determine this.

Note that connections between GIN and GOUT, and LIN and LOUT are automatically resolved by PSoC Designer when they are set in a differential configuration with an adjacent CT block.

Table 66: Analog Continuous Time Block xx Control 0 Register

Bit #	7	6	5	4	3	2	1	0
POR	0	0	0	0	0	0	0	0
Read/Write	RW	RW	RW	RW	RW	RW	RW	RW
Bit Name	RTap-Mux[3]	RTap-Mux[2]	RTap-Mux[1]	RTap-Mux[0]	Gain	RTopMux	RBotMux[1]	RBotMux[0]

Bit [7:4]: RTapMux [3:0] Encoding for selecting 1 of 16 resistor taps

0 0 0 0 = Rf 15 = Ri 01 = Loss .0625 / Gain 16.00
 0 0 0 1 = Rf 14 = Ri 02 = Loss .1250 / Gain 8.000
 0 0 1 0 = Rf 13 = Ri 03 = Loss .1875 / Gain 5.333
 0 0 1 1 = Rf 12 = Ri 04 = Loss .2500 / Gain 4.000
 0 1 0 0 = Rf 11 = Ri 05 = Loss .3125 / Gain 3.200
 0 1 0 1 = Rf 10 = Ri 06 = Loss .3750 / Gain 2.667
 0 1 1 0 = Rf 09 = Ri 07 = Loss .4375 / Gain 2.286
 0 1 1 1 = Rf 08 = Ri 08 = Loss .5000 / Gain 2.000
 1 0 0 0 = Rf 07 = Ri 09 = Loss .5625 / Gain 1.778
 1 0 0 1 = Rf 06 = Ri 10 = Loss .6250 / Gain 1.600
 1 0 1 0 = Rf 05 = Ri 11 = Loss .6875 / Gain 1.455
 1 0 1 1 = Rf 04 = Ri 12 = Loss .7500 / Gain 1.333
 1 1 0 0 = Rf 03 = Ri 13 = Loss .8125 / Gain 1.231
 1 1 0 1 = Rf 02 = Ri 14 = Loss .8750 / Gain 1.143
 1 1 1 0 = Rf 01 = Ri 15 = Loss .9375 / Gain 1.067
 1 1 1 1 = Rf 00 = Ri 16 = Loss 1.000 / Gain 1.000

Bit 3: Gain Select gain or loss configuration for output tap

0 = Loss
 1 = Gain

Bit 2: RTopMux Encoding for feedback resistor select

0 = Rtop to Vcc
 1 = Rtop to op-amp's output

Bit [1:0]: RBotMux [1:0] Encoding for feedback resistor select

	ACA00	ACA01	ACA02	ACA03
0 0 =	ACA01	ACA00	ACA03	ACA02
0 1 =	AGND	AGND	AGND	AGND
1 0 =	Vss	Vss	Vss	Vss
1 1 =	ASA10	ASB11	ASA12	ASB13

Analog Continuous Time Block 00 Control 0 Register (ACA00CR0, Address = Bank 0/1, 71h)
 Analog Continuous Time Block 01 Control 0 Register (ACA01CR0, Address = Bank 0/1, 75h)
 Analog Continuous Time Block 02 Control 0 Register (ACA02CR0, Address = Bank 0/1, 79h)
 Analog Continuous Time Block 03 Control 0 Register (ACA03CR0, Address = Bank 0/1, 7Dh)

10.7.2.2 Analog Continuous Time Block xx Control 1 Register

The PMux bits control the multiplexing of inputs to the non-inverting input of the op-amp. There are physically only 7 inputs.

The 8th code (111) will leave the input floating. This is not desirable, and should be avoided.

The NMux bits control the multiplexing of inputs to the inverting input of the op-amp. There are physically only 7 inputs.

CompBus controls a tri-state buffer that drives the comparator logic. If no PSoC block in the analog column is driving the comparator bus, it will be driven low externally to the blocks.

AnalogBus controls the analog output bus. A CMOS switch connects the op-amp output to the analog bus.

Table 67: Analog Continuous Time Block xx Control 1 Register

Bit #	7	6	5	4	3	2	1	0
POR	0	0	0	0	0	0	0	0
Read/Write	RW	RW	RW	RW	RW	RW	RW	RW
Bit Name	AnalogBus	CompBus	NMux2	NMux1	NMux0	PMux2	PMux1	PMux0

Bit 7: AnalogBus Enable output to the analog bus
0 = Disable analog bus driven by this block
1 = Enable analog bus driven by this block

Bit 6: CompBus Enable output to the comparator bus
0 = Disable comparator bus driven by this block
1 = Enable comparator bus driven by this block

Bit [5:3]: NMux [2:0] Encoding for negative input select

	<u>ACA00</u>	<u>ACA01</u>	<u>ACA02</u>	<u>ACA03</u>
0 0 0 =	ACA01	ACA00	ACA03	ACA02
0 0 1 =	AGND	AGND	AGND	AGND
0 1 0 =	REFLO	REFLO	REFLO	REFLO
0 1 1 =	REFHI	REFHI	REFHI	REFHI
1 0 0 ¹ =	ACA00	ACA01	ACA02	ACA03
1 0 1 =	ASA10	ASB11	ASA12	ASB13
1 1 0 =	ASB11	ASA10	ASB13	ASA12
1 1 1 =	Reserved	Reserved	Reserved	Reserved

Bit [2:0]: PMux [2:0] Encoding for positive input select

	<u>ACA00</u>	<u>ACA01</u>	<u>ACA02</u>	<u>ACA03</u>
0 0 0 =	REFLO	ACA02	ACA01	REFLO
0 0 1 =	Port Inputs	Port Inputs	Port Inputs	Port Inputs
0 1 0 =	ACA01	ACA00	ACA03	ACA02
0 1 1 =	AGND	AGND	AGND	AGND
1 0 0 =	ASA10	ASB11	ASA12	ASB13
1 0 1 =	ASB11	ASA10	ASB13	ASA12
1 1 0 =	ABUS0	ABUS1	ABUS2	ABUS3
1 1 1 =	Reserved	Reserved	Reserved	Reserved

1. This in fact is the feedback input of the MUX.

Analog Continuous Time Block 00 Control 1 Register (ACA00CR1, Address = Bank 0/1, 72h)
Analog Continuous Time Block 01 Control 1 Register (ACA01CR1, Address = Bank 0/1, 76h)
Analog Continuous Time Block 02 Control 1 Register (ACA02CR1, Address = Bank 0/1, 7Ah)
Analog Continuous Time Block 03 Control 1 Register (ACA03CR1, Address = Bank 0/1, 7Eh)

10.7.2.3 Analog Continuous Time Type A Block xx Control 2 Register

CPhase controls which internal clock phase the comparator data is latched on.

can be obtained if the amplifier is being used as a comparator.

CLatch controls whether the latch is active or if it is always transparent.

TestMux – selects block bypass mode for testing and characterization purposes.

CompCap controls whether the compensation capacitor is switched in or not in the op-amp. By not switching in the compensation capacitance, a much faster response

Power – encoding for selecting 1 of 4 power levels. The blocks always power up in the off state.

Table 68: Analog Continuous Time Type A Block xx Control 2 Register

Bit #	7	6	5	4	3	2	1	0
POR	0	0	0	0	0	0	0	0
Read/Write	RW	RW	RW	RW	RW	RW	RW	RW
Bit Name	CPhase	CLatch	CompCap	TestMux[2]	TestMux[1]	TestMux[0]	Power[1]	Power[0]

Bit 7: CPhase

0 = Comparator Control latch transparent on PHI1
1 = Comparator Control latch transparent on PHI2

Bit 6: CLatch

0 = Comparator Control latch is always transparent
1 = Comparator Control latch is active

Bit 5: CompCap

0 = Comparator Mode
1 = Op-amp Mode

Bit [4:2]: TestMux [2:0] Select block bypass mode for testing and characterization purposes

	<u>ACA00</u>	<u>ACA01</u>	<u>ACA02</u>	<u>ACA03</u>
1 0 0 = Positive Input to...	ABUS0	ABUS1	ABUS2	ABUS3
1 0 1 = AGND to...	ABUS0	ABUS1	ABUS2	ABUS3
1 1 0 = REFLO to...	ABUS0	ABUS1	ABUS2	ABUS3
1 1 1 = REFHI to...	ABUS0	ABUS1	ABUS2	ABUS3
0 x x = All Paths Off				

Bit [1:0]: Power [1:0] Encoding for selecting 1 of 4 power levels

0 0 = Off
0 1 = Low (60 μ A)
1 0 = Med (150 μ A)
1 1 = High (500 μ A)

Analog Continuous Time Block 00 Control 2 Register (ACA00CR2, Address = Bank 0/1, 73h)

Analog Continuous Time Block 01 Control 2 Register (ACA01CR2, Address = Bank 0/1, 77h)

Analog Continuous Time Block 02 Control 2 Register (ACA02CR2, Address = Bank 0/1, 7Bh)

Analog Continuous Time Block 03 Control 2 Register (ACA03CR2, Address = Bank 0/1, 7Fh)

10.8 Analog Switch Cap Type A PSoC Blocks

10.8.1 Introduction

The Analog Switch Cap Type A PSoC blocks are built around an operational amplifier. There are several analog muxes that are controlled by register-bit settings in the control registers that determine the signal topology inside the block. There are also four arrays of unit value capacitors that are located in the feedback path for the op-amp, and are switched by two phase clocks, PHI1 and PHI2. These four capacitor arrays are labeled A Cap Array, B Cap Array, C Cap Array, and F Cap Array. There is also an analog comparator connected to the output OUT, which converts analog comparisons into digital signals.

There are three discrete outputs from this block. These outputs are:

1. The analog output bus (ABUS), which is an analog bus resource that is shared by all of the analog blocks in the analog column for that block.
2. The comparator bus (CBUS), which is a digital bus that is a resource that is shared by all of the analog blocks in a column for that block.
3. The output bus (OUT), which is an analog bus resource that is shared by all of the analog blocks in a column and connects to one of the analog output buffers, to send a signal externally to the device.

SC Integrator Block A supports Delta-Sigma, Successive Approximation and Incremental A/D Conversion, Capacitor DACs, and SC filters. It has three input arrays of binarily-weighted switched capacitors, allowing user programmability of the capacitor weights. This provides summing capability of two (CDAC) scaled inputs, and a non-switched capacitor input. Since the input of SC Block A has this additional switched capacitor, it is configured for the input stage of such a switched capacitor biquad filter. When followed by an SC Block B Integrator, this combination of blocks can be used to provide a full Switched Capacitor Biquad.

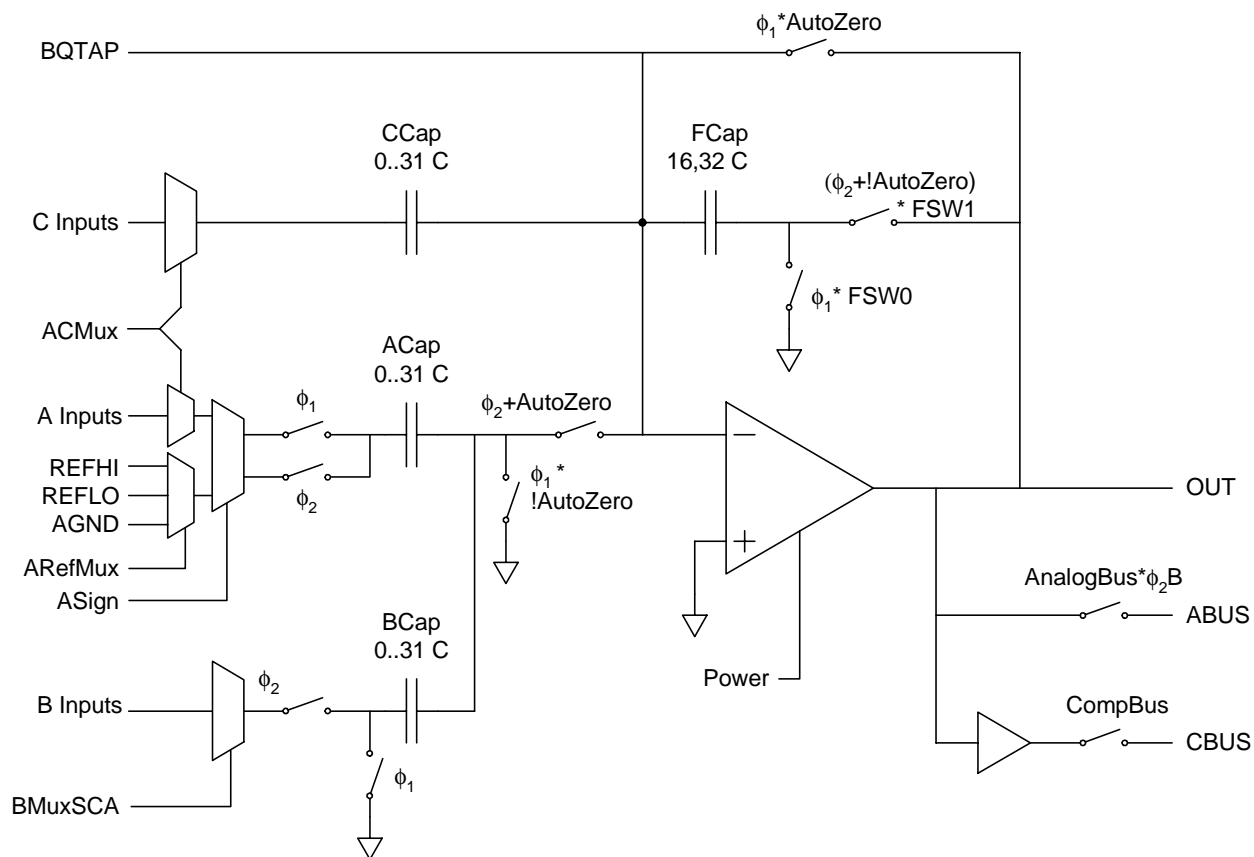

Figure 22: Analog Switch Cap Type A PSoC Blocks

10.8.2 Local Interconnect

10.8.2.1 AMux

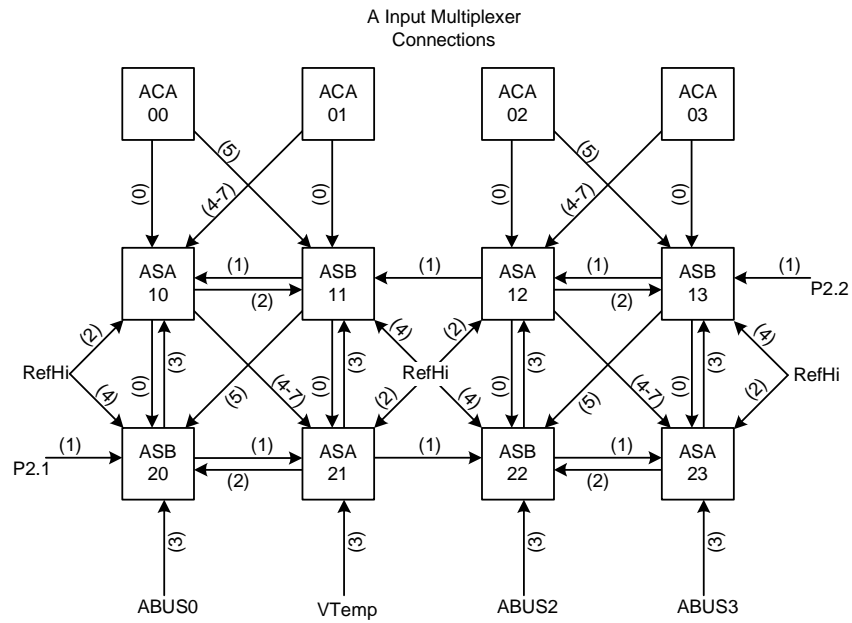

Figure 23: AMux Connections

10.8.2.2 CMux

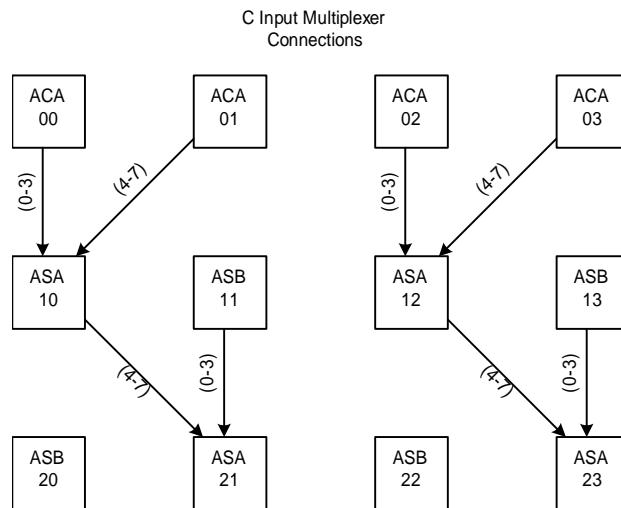

Figure 24: CMux Connections

10.8.2.3 ACMux

The ACMux, as shown in Analog Switch Cap Type A Block xx Control 1 Register, controls the input muxing for both the A and C capacitor branches. The high order bit, ACMux[2], selects one of two inputs for the C branch.

However, when the bit is high, it also overrides the two low order bits, forcing the A and C branches to the same source. The resulting condition is used to construct low pass biquad filters. See the individual AMux and CMux diagrams.

10.8.2.4 BMuxSCA/SCB

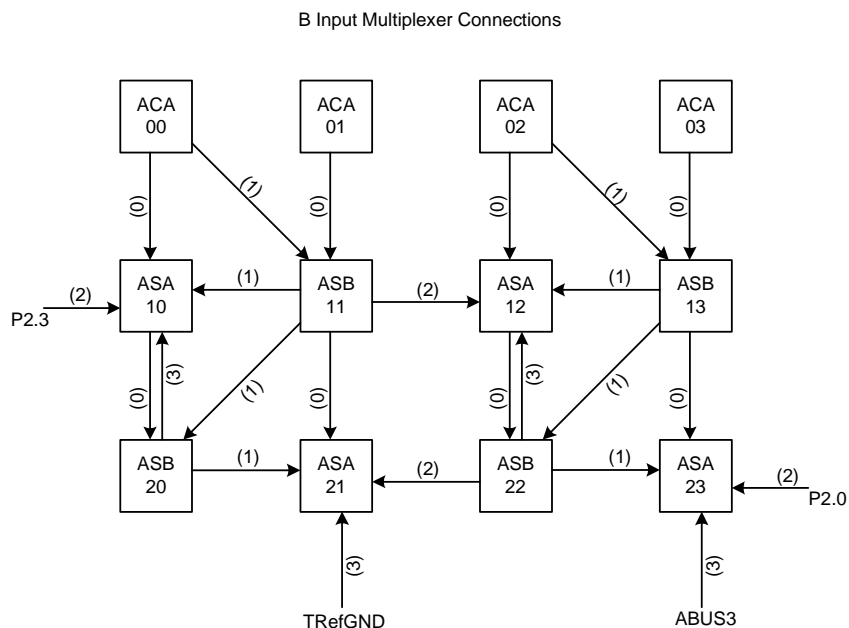

Figure 25: BMuxSCA/SCB Connections

10.8.3 Registers

10.8.3.1 Analog Switch Cap Type A Block xx Control 0 Register

FCap controls the size of the switched feedback capacitor in the integrator.

ClockPhase controls the internal clock phasing relative to the input clock phasing. ClockPhase affects the output of the analog column bus which is controlled by the

AnalogBus bit in Control 2 Register (ASA10CR2, ASA12CR2, ASA21CR2, ASA23CR2).

ASign controls the switch phasing of the switches on the bottom plate of the ACap capacitor. The bottom plate samples the input or the reference.

The ACap bits set the value of the capacitor in the A path.

Table 69: Analog Switch Cap Type A Block xx Control 0 Register

Bit #	7	6	5	4	3	2	1	0
POR	0	0	0	0	0	0	0	0
Read/Write	RW	RW	RW	RW	RW	RW	RW	RW
Bit Name	FCap	ClockPhase	ASign	ACap[4]	ACap[3]	ACap[2]	ACap[1]	ACap[0]

Table 69: Analog Switch Cap Type A Block xx Control 0 Register, continued**Bit 7: FCap** F Capacitor value selection bit

0 = 16 capacitor units
 1 = 32 capacitor units

Bit 6: ClockPhase Clock phase select, will invert clocks internal to the blocks. During normal operation of an SC block for the amplifier of a column enabled to drive the output bus, the connection is only made for the last half of PHI2 (during PHI1 and for the first half of PHI2, the output bus floats at the last voltage to which it was driven). This forms a sample and hold operation using the output bus and its associated capacitance. This design prevents the output bus from being perturbed by the intermediate states of the SC operation (often a reset state for PHI1 and settling to the valid state during PHI2)

Following are the exceptions: 1) If the ClockPhase bit in CR0 (for the SC block in question) is set to 1, then the output is enabled for the whole of PHI2. 2) If the SHDIS signal is set in bit 6 of the Analog Clock Select Register, then sample and hold operation is disabled for all columns and all enabled outputs of SC blocks are connected to their respective output busses for the entire period of their respective PHI2s

0 = Internal PHI1 = External PHI1
 1 = Internal PHI1 = External PHI2

This bit also affects the latching of the comparator output (CBUS). Both clock phases, PHI1 and PHI2, are involved in the output latching mechanism. The capture of the next value to be output from the latch (capture point event) happens during the falling edge of one clock phase, and the rising edge of the other clock phase will cause the value to come out (output point event). This bit determines which clock phase triggers the capture point event, and the other clock will trigger the output point event. The value output to the comparator bus will remain stable between output point events.

0 = Capture Point Event triggered by Falling PHI2, Output Point Event triggered by Rising PHI1
 1 = Capture Point Event triggered by Falling PHI1, Output Point Event triggered by Rising PHI2

Bit 5: ASign

0 = Input sampled on Internal PHI1, Reference Input sampled on internal PHI2
 1 = Input sampled on Internal PHI2, Reference Input sampled on internal PHI1

Bit [4:0]: ACap [4:0] Binary encoding for 32 possible capacitor sizes for A Capacitor:

0 0 0 0 0 = 0 Capacitor units in array	1 0 0 0 0 = 16 Capacitor units in array
0 0 0 0 1 = 1 Capacitor units in array	1 0 0 0 1 = 17 Capacitor units in array
0 0 0 1 0 = 2 Capacitor units in array	1 0 0 1 0 = 18 Capacitor units in array
0 0 0 1 1 = 3 Capacitor units in array	1 0 0 1 1 = 19 Capacitor units in array
0 0 1 0 0 = 4 Capacitor units in array	1 0 1 0 0 = 20 Capacitor units in array
0 0 1 0 1 = 5 Capacitor units in array	1 0 1 0 1 = 21 Capacitor units in array
0 0 1 1 0 = 6 Capacitor units in array	1 0 1 1 0 = 22 Capacitor units in array
0 0 1 1 1 = 7 Capacitor units in array	1 0 1 1 1 = 23 Capacitor units in array
0 1 0 0 0 = 8 Capacitor units in array	1 1 0 0 0 = 24 Capacitor units in array
0 1 0 0 1 = 9 Capacitor units in array	1 1 0 0 1 = 25 Capacitor units in array
0 1 0 1 0 = 10 Capacitor units in array	1 1 0 1 0 = 26 Capacitor units in array
0 1 0 1 1 = 11 Capacitor units in array	1 1 0 1 1 = 27 Capacitor units in array
0 1 1 0 0 = 12 Capacitor units in array	1 1 1 0 0 = 28 Capacitor units in array
0 1 1 0 1 = 13 Capacitor units in array	1 1 1 0 1 = 29 Capacitor units in array
0 1 1 1 0 = 14 Capacitor units in array	1 1 1 1 0 = 30 Capacitor units in array
0 1 1 1 1 = 15 Capacitor units in array	1 1 1 1 1 = 31 Capacitor units in array

Analog Switch Cap Type A Block 10 Control 0 Register (ASA10CR0, Address = Bank 0/1, 80h)

Analog Switch Cap Type A Block 12 Control 0 Register (ASA12CR0, Address = Bank 0/1, 88h)

Analog Switch Cap Type A Block 21 Control 0 Register (ASA21CR0, Address = Bank 0/1, 94h)

Analog Switch Cap Type A Block 23 Control 0 Register (ASA23CR0, Address = Bank 0/1, 9Ch)

10.8.3.2 Analog Switch Cap Type A Block xx Control 1 Register

ACMux controls the input muxing for both the A and C capacitor branches. The high order bit, ACMux[2], selects one of two inputs for the C branch. However, when the bit is high, it also overrides the two low order bits, forcing the A and C branches to the same source.

The resulting condition is used to construct low pass biquad filters.

The BCap bits set the value of the capacitor in the B path.

Table 70: Analog Switch Cap Type A Block xx Control 1 Register

Bit #	7	6	5	4	3	2	1	0
POR	0	0	0	0	0	0	0	0
Read/Write	RW	RW	RW	RW	RW	RW	RW	RW
Bit Name	ACMux[2]	ACMux[1]	ACMux[0]	BCap[4]	BCap[3]	BCap[2]	BCap[1]	BCap[0]

Bit [7:5] ACMux [2:0] Encoding for selecting A and C inputs. (Note that available mux inputs vary by individual PSoC block.)

ASA10		ASA21		ASA12		ASA23	
A Inputs	C Inputs	A Inputs	C Inputs	A Inputs	C Inputs	A Inputs	C Inputs
0 0 0	= ACA00 ACA00	ASB11	ASB11	ACA02	ACA02	ASB13	ASB13
0 0 1	= ASB11 ACA00	ASB20	ASB11	ASB13	ACA02	ASB22	ASB13
0 1 0	= REFHI ACA00	REFHI	ASB11	REFHI	ACA02	REFHI	ASB13
0 1 1	= ASB20 ACA00	Vtemp	ASB11	ASB22	ACA02	ABUS3	ASB13
1 0 0	= ACA01 Reserved	ASA10	Reserved	ACA03	Reserved	ASA12	Reserved
1 0 1	= Reserved Reserved	Reserved	Reserved	Reserved	Reserved	Reserved	Reserved
1 1 0	= Reserved Reserved	Reserved	Reserved	Reserved	Reserved	Reserved	Reserved
1 1 1	= Reserved Reserved	Reserved	Reserved	Reserved	Reserved	Reserved	Reserved

Bit [4:0]: BCap [4:0] Binary encoding for 32 possible capacitor sizes for B Capacitor:

0 0 0 0 0 = 0 Capacitor units in array	1 0 0 0 0 = 16 Capacitor units in array
0 0 0 0 1 = 1 Capacitor units in array	1 0 0 0 1 = 17 Capacitor units in array
0 0 0 1 0 = 2 Capacitor units in array	1 0 0 1 0 = 18 Capacitor units in array
0 0 0 1 1 = 3 Capacitor units in array	1 0 0 1 1 = 19 Capacitor units in array
0 0 1 0 0 = 4 Capacitor units in array	1 0 1 0 0 = 20 Capacitor units in array
0 0 1 0 1 = 5 Capacitor units in array	1 0 1 0 1 = 21 Capacitor units in array
0 0 1 1 0 = 6 Capacitor units in array	1 0 1 1 0 = 22 Capacitor units in array
0 0 1 1 1 = 7 Capacitor units in array	1 0 1 1 1 = 23 Capacitor units in array
0 1 0 0 0 = 8 Capacitor units in array	1 1 0 0 0 = 24 Capacitor units in array
0 1 0 0 1 = 9 Capacitor units in array	1 1 0 0 1 = 25 Capacitor units in array
0 1 0 1 0 = 10 Capacitor units in array	1 1 0 1 0 = 26 Capacitor units in array
0 1 0 1 1 = 11 Capacitor units in array	1 1 0 1 1 = 27 Capacitor units in array
0 1 1 0 0 = 12 Capacitor units in array	1 1 1 0 0 = 28 Capacitor units in array
0 1 1 0 1 = 13 Capacitor units in array	1 1 1 0 1 = 29 Capacitor units in array
0 1 1 1 0 = 14 Capacitor units in array	1 1 1 1 0 = 30 Capacitor units in array
0 1 1 1 1 = 15 Capacitor units in array	1 1 1 1 1 = 31 Capacitor units in array

Analog Switch Cap Type A Block 10 Control 1 Register (ASA10CR1, Address = Bank 0/1, 81h)

Analog Switch Cap Type A Block 12 Control 1 Register (ASA12CR1, Address = Bank 0/1, 89h)

Analog Switch Cap Type A Block 21 Control 1 Register (ASA21CR1, Address = Bank 0/1, 95h)

Analog Switch Cap Type A Block 23 Control 1 Register (ASA23CR1, Address = Bank 0/1, 9Dh)

10.8.3.3 Analog Switch Cap Type A Block xx Control 2 Register

AnalogBus gates the output to the analog column bus. The output on the analog column bus is affected by the state of the ClockPhase bit in Control 0 Register (ASA10CR0, ASA12CR0, ASA21CR0, ASA23CR0). If AnalogBus is set to 0, the output to the analog column bus is tri-stated. If AnalogBus is set to 1, the signal that is output to the analog column bus is selected by the ClockPhase bit. If the ClockPhase bit is 0, the block output is gated by sampling clock on last part of PHI2. If the ClockPhase bit is 1, the block output continuously drives the analog column bus.

CompBus controls the output to the column comparator bus. Note that if the comparator bus is not driven by anything in the column, it is pulled low. The comparator output is evaluated on the rising edge of internal PHI1 and is latched so it is available during internal PHI2.

AutoZero controls the shorting of the output to the inverting input of the op-amp. When shorted, the op-amp is basically a follower. The output is the op-amp offset. By using the feedback capacitor of the integrator, the block can memorize the offset and create an offset cancellation scheme. AutoZero also controls a pair of switches between the A and B branches and the summing node of the op-amp. If AutoZero is enabled, then the pair of switches is active. AutoZero also affects the function of the FSW1 bit in Control 3 Register.

The CCap bits set the value of the capacitor in the C path.

Table 71: Analog Switch Cap Type A Block xx Control 2 Register

Bit #	7	6	5	4	3	2	1	0
POR	0	0	0	0	0	0	0	0
Read/Write	RW	RW	RW	RW	RW	RW	RW	RW
Bit Name	AnalogBus	CompBus	AutoZero	CCap[4]	CCap[3]	CCap[2]	CCap[1]	CCap[0]

Bit 7: AnalogBus Enable output to the analog bus

0 = Disable output to analog column bus

1 = Enable output to analog column bus

(The output on the analog column bus is affected by the state of the ClockPhase bit in Control 0 Register (ASA10CR0, ASA12CR0, ASA21CR0, ASA23CR0). If AnalogBus is set to 0, the output to the analog column bus is tri-stated. If AnalogBus is set to 1, the signal that is output to the analog column bus is selected by the ClockPhase bit. If the ClockPhase bit is 0, the block output is gated by sampling clock on last part of PHI2. If the ClockPhase bit is 1, the block output continuously drives the analog column bus.)

Bit 6: CompBus Enable output to the comparator bus

0 = Disable output to comparator bus

1 = Enable output to comparator bus

Bit 5: AutoZero Bit for controlling gated switches

0 = Shorting switch is not active. Input cap branches shorted to op-amp input

1 = Shorting switch is enabled during internal PHI1. Input cap branches shorted to analog ground during internal PHI1 and to op-amp input during internal PHI2.

Bit [4:0]: CCap [4:0] Binary encoding for 32 possible capacitor sizes for C Capacitor:

0 0 0 0 0 = 0 Capacitor units in array	1 0 0 0 0 = 16 Capacitor units in array
0 0 0 0 1 = 1 Capacitor units in array	1 0 0 0 1 = 17 Capacitor units in array
0 0 0 1 0 = 2 Capacitor units in array	1 0 0 1 0 = 18 Capacitor units in array
0 0 0 1 1 = 3 Capacitor units in array	1 0 0 1 1 = 19 Capacitor units in array
0 0 1 0 0 = 4 Capacitor units in array	1 0 1 0 0 = 20 Capacitor units in array
0 0 1 0 1 = 5 Capacitor units in array	1 0 1 0 1 = 21 Capacitor units in array
0 0 1 1 0 = 6 Capacitor units in array	1 0 1 1 0 = 22 Capacitor units in array
0 0 1 1 1 = 7 Capacitor units in array	1 0 1 1 1 = 23 Capacitor units in array
0 1 0 0 0 = 8 Capacitor units in array	1 1 0 0 0 = 24 Capacitor units in array
0 1 0 0 1 = 9 Capacitor units in array	1 1 0 0 1 = 25 Capacitor units in array
0 1 0 1 0 = 10 Capacitor units in array	1 1 0 1 0 = 26 Capacitor units in array
0 1 0 1 1 = 11 Capacitor units in array	1 1 0 1 1 = 27 Capacitor units in array
0 1 1 0 0 = 12 Capacitor units in array	1 1 1 0 0 = 28 Capacitor units in array
0 1 1 0 1 = 13 Capacitor units in array	1 1 1 0 1 = 29 Capacitor units in array
0 1 1 1 0 = 14 Capacitor units in array	1 1 1 1 0 = 30 Capacitor units in array
0 1 1 1 1 = 15 Capacitor units in array	1 1 1 1 1 = 31 Capacitor units in array

Analog Switch Cap Type A Block 10 Control 2 Register (ASA10CR2, Address = Bank 0/1, 82h)

Analog Switch Cap Type A Block 12 Control 2 Register (ASA12CR2, Address = Bank 0/1, 8Ah)

Analog Switch Cap Type A Block 21 Control 2 Register (ASA21CR2, Address = Bank 0/1, 96h)

Analog Switch Cap Type A Block 23 Control 2 Register (ASA23CR2, Address = Bank 0/1, 9Eh)

10.8.3.4 Analog Switch Cap Type A Block xx Control 3 Register

ARefMux selects the reference input of the A capacitor branch.

FSW1 is used to control a switch in the integrator capacitor path. It connects the output of the op-amp to the integrating cap. The state of the switch is affected by the state of the AutoZero bit in Control 2 Register (ASA10CR2, ASA12CR2, ASA21CR2, ASA23CR2). If the FSW1 bit is set to 0, the switch is always disabled. If the FSW1 bit is set to 1, the AutoZero bit determines the state of the switch. If the AutoZero bit is 0, the switch is

enabled at all times. If the AutoZero bit is 1, the switch is enabled only when the internal PHI2 is high.

FSW0 is used to control a switch in the integrator capacitor path. It connects the output of the op-amp to analog ground.

BMuxSCA controls the muxing to the input of the B capacitor branch.

Power – encoding for selecting 1 of 4 power levels. The block always powers up in the off state.

Table 72: Analog Switch Cap Type A Block xx Control 3 Register

Bit #	7	6	5	4	3	2	1	0
POR	0	0	0	0	0	0	0	0
Read/Write	RW	RW	RW	RW	RW	RW	RW	RW
Bit Name	ARefMux[1]	ARefMux[0]	FSW[1]	FSW[0]	BMuxSCA[1]	BMuxSCA[0]	Power[1]	Power[0]

Bit [7:6]: ARefMux [1:0] Encoding for selecting reference input
 0 0 = Analog ground is selected
 0 1 = REFHI input selected (This is usually the high reference)
 1 0 = REFLO input selected (This is usually the low reference)
 1 1 = Reference selection is driven by the comparator (When output comparator node is set high, the input is set to REFHI. When set low, the input is set to REFLO)

Bit 5: FSW1 Bit for controlling gated switches
 0 = Switch is disabled
 1 = If the FSW1 bit is set to 1, the state of the switch is determined by the AutoZero bit. If the AutoZero bit is 0, the switch is enabled at all times. If the AutoZero bit is 1, the switch is enabled only when the internal PHI2 is high

Bit 4: FSW0 Bits for controlling gated switches
 0 = Switch is disabled
 1 = Switch is enabled when PHI1 is high

Bit [3:2] BMuxSCA [1:0] Encoding for selecting B inputs. (Note that the available mux inputs vary by individual PSoC block.)

	ASA10	ASA21	ASA12	ASA23
0 0 =	ACA00	ASB11	ACA02	ASB13
0 1 =	ASB11	ASB20	ASB13	ASB22
1 0 =	P2.3	ASB22	ASB11	P2.0
1 1 =	ASB20	T _{ref} GND	ASB22	ABUS3

Bit [1:0]: Power [1:0] Encoding for selecting 1 of 4 power levels
 0 0 = Off
 0 1 = 10 μ A, typical
 1 0 = 50 μ A, typical
 1 1 = 200 μ A, typical

Analog Switch Cap Type A Block 10 Control 3 Register (ASA10CR3, Address = Bank 0/1, 83h)

Analog Switch Cap Type A Block 12 Control 3 Register (ASA12CR3, Address = Bank 0/1, 8Bh)

Analog Switch Cap Type A Block 21 Control 3 Register (ASA21CR3, Address = Bank 0/1, 97h)

Analog Switch Cap Type A Block 23 Control 3 Register (ASA23CR3, Address = Bank 0/1, 9Fh)

10.9 Analog Switch Cap Type B PSoC Blocks

10.9.1 Introduction

The Analog Switch Cap Type B PSoC blocks are built around an operational amplifier. There are several analog muxes that are controlled by register-bit settings in the control registers that determine the signal topology inside the block. There are also four arrays of unit value capacitors that are located in the feedback path for the op-amp, and are switched by two phase clocks, PHI1 and PHI2. These four capacitor arrays are labeled A Cap Array, B Cap Array, C Cap Array, and F Cap Array. There is also an analog comparator connected to the output OUT, which converts analog comparisons into digital signals.

There are three discrete outputs from this block. These outputs are:

1. The analog output bus (ABUS), which is an analog bus resource that is shared by all of the analog blocks in the analog column for that block.
2. The comparator bus (CBUS), which is a digital bus that is a resource that is shared by all of the analog blocks in a column for that block.
3. The output bus (OUT), which is an analog bus resource that is shared by all of the analog blocks in a column and connects to one of the analog output buffers, to send a signal externally to the device.

The SCB block also supports Delta-Sigma, Successive Approximation and Incremental A/D Conversion, Capacitor DACs, and SC filters. It has two input arrays of switched capacitors, and a Non-Switched capacitor feedback array from the output. When preceded by an SC Block A Integrator, the combination can be used to provide a full Switched Capacitor Biquad.

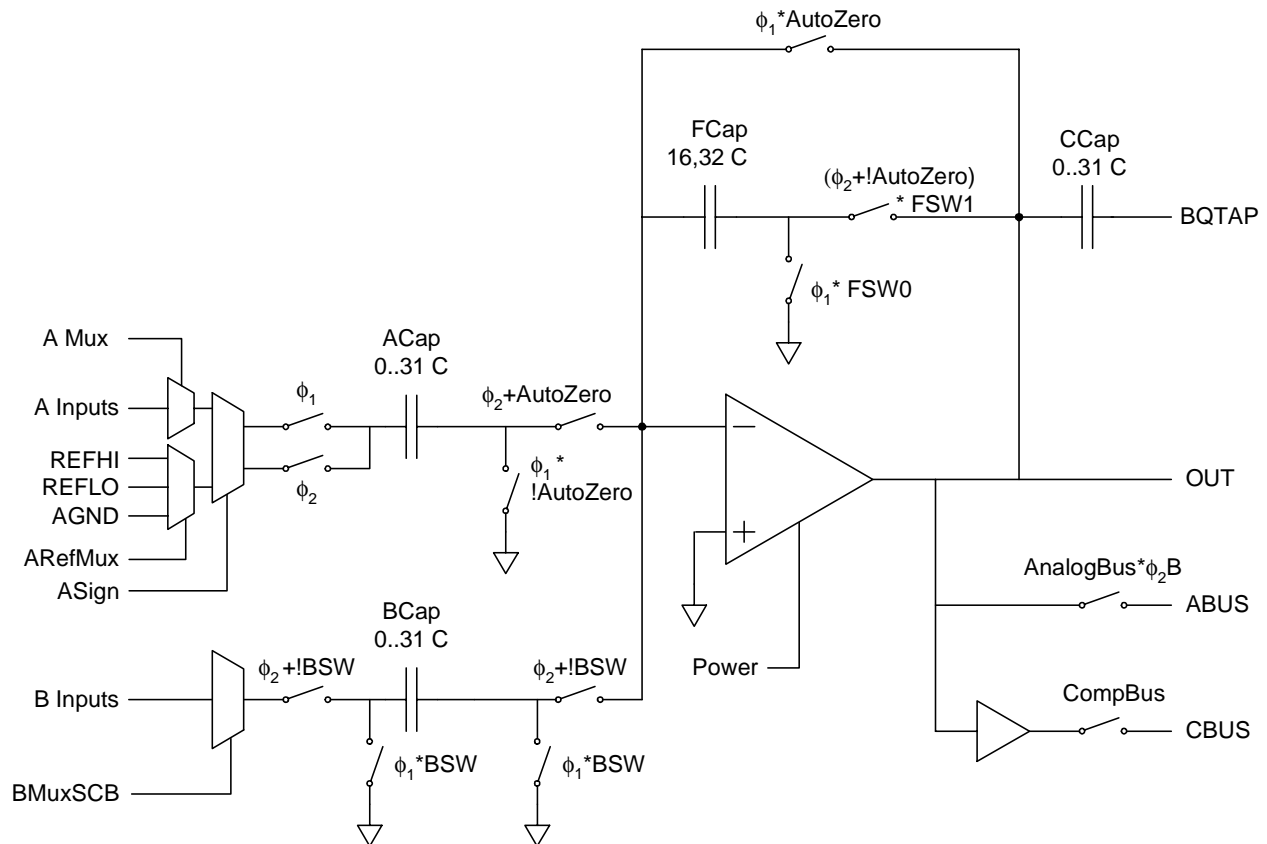

Figure 26: Analog Switch Cap Type B PSoC Blocks

10.9.2 Registers

10.9.2.1 Analog Switch Cap Type B Block xx Control 0 Register

FCap controls the size of the switched feedback capacitor in the integrator.

ClockPhase controls the internal clock phasing relative to the input clock phasing. ClockPhase affects the output of the analog column bus which is controlled by the AnalogBus bit in Control 2 Register (ASB11CR2, ASB13CR2, ASB20CR2, ASB22CR2).

ASign controls the switch phasing of the switches on the bottom plate of the A capacitor. The bottom plate samples the input or the reference.

The ACap bits set the value of the capacitor in the A path.

Table 73: Analog Switch Cap Type B Block xx Control 0 Register

Bit #	7	6	5	4	3	2	1	0
POR	0	0	0	0	0	0	0	0
Read/Write	RW	RW	RW	RW	RW	RW	RW	RW
Bit Name	FCap	ClockPhase	ASign	ACap[4]	ACap[3]	ACap[2]	ACap[1]	ACap[0]

Table 73: Analog Switch Cap Type B Block xx Control 0 Register, continued**Bit 7: FCap** F Capacitor value selection bit

0 = 16 capacitor units
1 = 32 capacitor units

Bit 6: ClockPhase Clock phase select, will invert clocks internal to the blocks. During normal operation of an SC block for the amplifier of a column enabled to drive the output bus, the connection is only made for the last half of PHI2 (during PHI1 and for the first half of PHI2, the output bus floats at the last voltage to which it was driven). This forms a sample and hold operation using the output bus and its associated capacitance. This design prevents the output bus from being perturbed by the intermediate states of the SC operation (often a reset state for PHI1 and settling to the valid state during PHI2)

Following are the exceptions: 1) If the ClockPhase bit in CR0 (for the SC block in question) is set to 1, then the output is enabled for the whole of PHI2. 2) If the SHDIS signal is set in bit 6 of the Analog Clock Select Register, then sample and hold operation is disabled for all columns and all enabled outputs of SC blocks are connected to their respective output busses for the entire period of their respective PHI2s

0 = Internal PHI1 = External PHI1
1 = Internal PHI1 = External PHI2

This bit also affects the latching of the comparator output (CBUS). Both clock phases, PHI1 and PHI2, are involved in the output latching mechanism. The capture of the next value to be output from the latch (capture point event) happens during the falling edge of one clock phase, and the rising edge of the other clock phase will cause the value to come out (output point event). This bit determines which clock phase triggers the capture point event, and the other clock will trigger the output point event. The value output to the comparator bus will remain stable between output point events.

0 = Capture Point Event triggered by Falling PHI2, Output Point Event triggered by Rising PHI1
1 = Capture Point Event triggered by Falling PHI1, Output Point Event triggered by Rising PHI2

Bit 5: ASign

0 = Input sampled on Internal PHI1, Reference Input sampled on internal PHI2
1 = Input sampled on Internal PHI2, Reference Input sampled on internal PHI1

Bit [4:0]: ACap [4:0] Binary encoding for 32 possible capacitor sizes for A Capacitor:

0 0 0 0 0 = 0 Capacitor units in array	1 0 0 0 0 = 16 Capacitor units in array
0 0 0 0 1 = 1 Capacitor units in array	1 0 0 0 1 = 17 Capacitor units in array
0 0 0 1 0 = 2 Capacitor units in array	1 0 0 1 0 = 18 Capacitor units in array
0 0 0 1 1 = 3 Capacitor units in array	1 0 0 1 1 = 19 Capacitor units in array
0 0 1 0 0 = 4 Capacitor units in array	1 0 1 0 0 = 20 Capacitor units in array
0 0 1 0 1 = 5 Capacitor units in array	1 0 1 0 1 = 21 Capacitor units in array
0 0 1 1 0 = 6 Capacitor units in array	1 0 1 1 0 = 22 Capacitor units in array
0 0 1 1 1 = 7 Capacitor units in array	1 0 1 1 1 = 23 Capacitor units in array
0 1 0 0 0 = 8 Capacitor units in array	1 1 0 0 0 = 24 Capacitor units in array
0 1 0 0 1 = 9 Capacitor units in array	1 1 0 0 1 = 25 Capacitor units in array
0 1 0 1 0 = 10 Capacitor units in array	1 1 0 1 0 = 26 Capacitor units in array
0 1 0 1 1 = 11 Capacitor units in array	1 1 0 1 1 = 27 Capacitor units in array
0 1 1 0 0 = 12 Capacitor units in array	1 1 1 0 0 = 28 Capacitor units in array
0 1 1 0 1 = 13 Capacitor units in array	1 1 1 0 1 = 29 Capacitor units in array
0 1 1 1 0 = 14 Capacitor units in array	1 1 1 1 0 = 30 Capacitor units in array
0 1 1 1 1 = 15 Capacitor units in array	1 1 1 1 1 = 31 Capacitor units in array

Analog Switch Cap Type B Block 11 Control 0 Register (ASB11CR0, Address = Bank 0/1, 84h)
Analog Switch Cap Type B Block 13 Control 0 Register (ASB13CR0, Address = Bank 0/1, 8Ch)
Analog Switch Cap Type B Block 20 Control 0 Register (ASB20CR0, Address = Bank 0/1, 90h)
Analog Switch Cap Type B Block 22 Control 0 Register (ASB22CR0, Address = Bank 0/1, 98h)

10.9.2.2 Analog Switch Cap Type B Block xx Control 1 Register

AMux controls the input muxing for the A capacitor branch. The BCap bits set the value of the capacitor in the B path.

Table 74: Analog Switch Cap Type B Block xx Control 1 Register

Bit #	7	6	5	4	3	2	1	0
POR	0	0	0	0	0	0	0	0
Read/Write	RW	RW	RW	RW	RW	RW	RW	RW
Bit Name	AMux[2]	AMux[1]	AMux[0]	BCap[4]	BCap[3]	BCap[2]	BCap[1]	BCap[0]

Bit [7:5]: AMux [2:0] Input muxing select for A capacitor branch. (Note that available mux inputs vary by individual PSoC block.)

<u>ASB11</u>	<u>ASB13</u>	<u>ASB20</u>	<u>ASB22</u>
0 0 0 = ACA01	ACA03	ASA10	ASA12
0 0 1 = ASA12	P2.2	P2.1	ASA21
0 1 0 = ASA10	ASA12	ASA21	ASA23
0 1 1 = ASA21	ASA23	ABUS0	ABUS2
1 0 0 = REFHI	REFHI	REFHI	REFHI
1 0 1 = ACA00	ACA02	ASB11	ASB13
1 1 0 = Reserved	Reserved	Reserved	Reserved
1 1 1 = Reserved	Reserved	Reserved	Reserved

Bit [4:0]: BCap [4:0] Binary encoding for 32 possible capacitor sizes for B Capacitor:

0 0 0 0 0 = 0 Capacitor units in array	1 0 0 0 0 = 16 Capacitor units in array
0 0 0 0 1 = 1 Capacitor units in array	1 0 0 0 1 = 17 Capacitor units in array
0 0 0 1 0 = 2 Capacitor units in array	1 0 0 1 0 = 18 Capacitor units in array
0 0 0 1 1 = 3 Capacitor units in array	1 0 0 1 1 = 19 Capacitor units in array
0 0 1 0 0 = 4 Capacitor units in array	1 0 1 0 0 = 20 Capacitor units in array
0 0 1 0 1 = 5 Capacitor units in array	1 0 1 0 1 = 21 Capacitor units in array
0 0 1 1 0 = 6 Capacitor units in array	1 0 1 1 0 = 22 Capacitor units in array
0 0 1 1 1 = 7 Capacitor units in array	1 0 1 1 1 = 23 Capacitor units in array
0 1 0 0 0 = 8 Capacitor units in array	1 1 0 0 0 = 24 Capacitor units in array
0 1 0 0 1 = 9 Capacitor units in array	1 1 0 0 1 = 25 Capacitor units in array
0 1 0 1 0 = 10 Capacitor units in array	1 1 0 1 0 = 26 Capacitor units in array
0 1 0 1 1 = 11 Capacitor units in array	1 1 0 1 1 = 27 Capacitor units in array
0 1 1 0 0 = 12 Capacitor units in array	1 1 1 0 0 = 28 Capacitor units in array
0 1 1 0 1 = 13 Capacitor units in array	1 1 1 0 1 = 29 Capacitor units in array
0 1 1 1 0 = 14 Capacitor units in array	1 1 1 1 0 = 30 Capacitor units in array
0 1 1 1 1 = 15 Capacitor units in array	1 1 1 1 1 = 31 Capacitor units in array

Analog Switch Cap Type B Block 11 Control 1 Register (ASB11CR1, Address = Bank 0/1, 85h)

Analog Switch Cap Type B Block 13 Control 1 Register (ASB13CR1, Address = Bank 0/1, 8Dh)

Analog Switch Cap Type B Block 20 Control 1 Register (ASB20CR1, Address = Bank 0/1, 91h)

Analog Switch Cap Type B Block 22 Control 1 Register (ASB22CR1, Address = Bank 0/1, 99h)

10.9.2.3 Analog Switch Cap Type B Block xx Control 2 Register

AnalogBus gates the output to the analog column bus. The output on the analog column bus is affected by the state of the ClockPhase bit in Control 0 Register (ASB11CR0, ASB13CR0, ASB20CR0, ASB22CR0). If AnalogBus is set to 0, the output to the analog column bus is tri-stated. If AnalogBus is set to 1, the ClockPhase bit selects the signal that is output to the analog-column bus. If the ClockPhase bit is 0, the block output is gated by sampling clock on last part of PHI2. If the ClockPhase bit is 1, the block ClockPhase continuously drives the analog column bus.

CompBus controls the output to the column comparator bus. Note that if the comparator bus is not driven by anything in the column, it is pulled low. The comparator output is evaluated on the rising edge of internal PHI1 and is latched so it is available during internal PHI2.

AutoZero controls the shorting of the output to the inverting input of the op-amp. When shorted, the op-amp is basically a follower. The output is the op-amp offset. By using the feedback capacitor of the integrator, the block can memorize the offset and create an offset cancellation scheme. AutoZero also controls a pair of switches between the A and B branches and the summing node of the op-amp. If AutoZero is enabled, then the pair of switches is active. AutoZero also affects the function of the FSW1 bit in Control 3 Register.

The CCap bits set the value of the capacitor in the C path.

Table 75: Analog Switch Cap Type B Block xx Control 2 Register

Bit #	7	6	5	4	3	2	1	0
POR	0	0	0	0	0	0	0	0
Read/ Write	RW	RW	RW	RW	RW	RW	RW	RW
Bit Name	AnalogBus	CompBus	AutoZero	CCap[4]	CCap[3]	CCap[2]	CCap[1]	CCap[0]

Bit 7: AnalogBus Enable output to the analog bus

0 = Disable output to analog column bus

1 = Enable output to analog column bus

(The output on the analog column bus is affected by the state of the ClockPhase bit in Control 0 Register (ASB11CR0, ASB13CR0, ASB20CR0, ASB22CR0). If AnalogBus is set to 0, the output to the analog column bus is tri-stated. If AnalogBus is set to 1, the ClockPhase bit selects the signal that is output to the analog column bus. If the ClockPhase bit is 0, the block output is gated by sampling clock on last part of PHI2. If the ClockPhase bit is 1, the block output continuously drives the analog column bus)

Bit 6: CompBus Enable output to the comparator bus

0 = Disable output to comparator bus

1 = Enable output to comparator bus

Bit 5: AutoZero Bit for controlling gated switches

0 = Shorting switch is not active. Input cap branches shorted to op-amp input

1 = Shorting switch is enabled during internal PHI1. Input cap branches shorted to analog ground during internal PHI1 and to op-amp input during internal PHI2.

Bit [4:0]: CCap [4:0] Binary encoding for 32 possible capacitor sizes for C Capacitor:

0 0 0 0 0 = 0 Capacitor units in array	1 0 0 0 0 = 16 Capacitor units in array
0 0 0 0 1 = 1 Capacitor units in array	1 0 0 0 1 = 17 Capacitor units in array
0 0 0 1 0 = 2 Capacitor units in array	1 0 0 1 0 = 18 Capacitor units in array
0 0 0 1 1 = 3 Capacitor units in array	1 0 0 1 1 = 19 Capacitor units in array
0 0 1 0 0 = 4 Capacitor units in array	1 0 1 0 0 = 20 Capacitor units in array
0 0 1 0 1 = 5 Capacitor units in array	1 0 1 0 1 = 21 Capacitor units in array
0 0 1 1 0 = 6 Capacitor units in array	1 0 1 1 0 = 22 Capacitor units in array
0 0 1 1 1 = 7 Capacitor units in array	1 0 1 1 1 = 23 Capacitor units in array
0 1 0 0 0 = 8 Capacitor units in array	1 1 0 0 0 = 24 Capacitor units in array
0 1 0 0 1 = 9 Capacitor units in array	1 1 0 0 1 = 25 Capacitor units in array
0 1 0 1 0 = 10 Capacitor units in array	1 1 0 1 0 = 26 Capacitor units in array
0 1 0 1 1 = 11 Capacitor units in array	1 1 0 1 1 = 27 Capacitor units in array
0 1 1 0 0 = 12 Capacitor units in array	1 1 1 0 0 = 28 Capacitor units in array
0 1 1 0 1 = 13 Capacitor units in array	1 1 1 0 1 = 29 Capacitor units in array
0 1 1 1 0 = 14 Capacitor units in array	1 1 1 1 0 = 30 Capacitor units in array
0 1 1 1 1 = 15 Capacitor units in array	1 1 1 1 1 = 31 Capacitor units in array

Analog Switch Cap Type B Block 11 Control 2 Register (ASB11CR2, Address = Bank 0/1, 86h)

Analog Switch Cap Type B Block 13 Control 2 Register (ASB13CR2, Address = Bank 0/1, 8Eh)

Analog Switch Cap Type B Block 20 Control 2 Register (ASB20CR2, Address = Bank 0/1, 92h)

Analog Switch Cap Type B Block 22 Control 2 Register (ASB22CR2, Address = Bank 0/1, 9Ah)

10.9.2.4 Analog Switch Cap Type B Block xx Control 3 Register

ARefMux selects the reference input of the A capacitor branch.

FSW1 is used to control a switch in the integrator capacitor path. It connects the output of the op-amp to the integrating cap. The state of the switch is affected by the state of the AutoZero bit in Control 2 Register (ASB11CR2, ASB13CR2, ASB20CR2, ASB22CR2). If the FSW1 bit is set to 0, the switch is always disabled. If the FSW1 bit is set to 1, the AutoZero bit determines the state of the switch. If the AutoZero bit is 0, the switch is enabled at all times. If the AutoZero bit is 1, the switch is enabled only when the internal PHI2 is high.

FSW0 is used to control a switch in the integrator capacitor path. It connects the output of the op-amp to analog ground.

BSW is used to control switching in the B branch. If disabled, the B capacitor branch is a continuous time branch like the C branch of the SC A Block. If enabled, then on internal PHI1, both ends of the cap are switched to analog ground. On internal PHI2, one end is switched to the B input and the other end is switched to the summing node.

BMuxSCB controls muxing to the input of the B capacitor branch. The B branch can be switched or unswitched.

Table 76: Analog Switch Cap Type B Block xx Control 3 Register

Bit #	7	6	5	4	3	2	1	0
POR	0	0	0	0	0	0	0	0
Read/Write	RW	RW	RW	RW	RW	RW	RW	RW
Bit Name	ARefMux[1]	ARefMux[0]	FSW[1]	FSW[0]	BSW	BMuxSCB	Power[1]	Power[0]

Bit [7:6]: ARefMux [1:0] Encoding for selecting reference input

0 0 = Analog ground is selected

0 1 = REFHI input selected (This is usually the high reference)

1 0 = REFLO input selected (This is usually the low reference)

1 1 = Reference selection is driven by the comparator (When output comparator node is set high, the input is set to REFHI. When set low, the input is set to REFLO)

Bit 5: FSW1 Bit for controlling gated switches

0 = Switch is disabled

FSW1 bit is set to 1; the state of the switch is determined by the AutoZero bit. If the AutoZero bit is 0, the switch is enabled at all times. If the AutoZero bit is 1, the switch is enabled only when the internal PHI2 is high

Bit 4: FSW0 Bits for controlling gated switches

0 = Switch is disabled

1 = Switch is enabled when PHI1 is high

Bit 3: BSW Enable switching in branch

0 = B branch is a continuous time path

1 = B branch is switched with internal PHI2 sampling

Bit 2: BMuxSCB Encoding for selecting B inputs. (Note that the available mux inputs vary by individual PSoC block)

ASB11 ASB13 ASB20 ASB22

0 = ACA00 ACA02 ASB11 ASB13

1 = ACA01 ACA03 ASA10 ASA12

Bit [1:0]: Power [1:0] Encoding for selecting 1 of 4 power levels

0 0 = Off

0 1 = 10 μ A, typical

1 0 = 50 μ A, typical

1 1 = 200 μ A, typical

Analog Switch Cap Type B Block 11 Control 3 Register (ASB11CR3, Address = Bank 0/1, 87h)

Analog Switch Cap Type B Block 13 Control 3 Register (ASB13CR3, Address = Bank 0/1, 8Fh)

Analog Switch Cap Type B Block 20 Control 3 Register (ASB20CR3, Address = Bank 0/1, 93h)

Analog Switch Cap Type B Block 22 Control 3 Register (ASB22CR3, Address = Bank 0/1, 9Bh)

10.10 Analog Comparator Bus

Each analog column has a dedicated comparator bus associated with it. Every analog PSoC block has a comparator output that can drive out on this bus, but the comparator output from only one analog block in a column can be actively driving the comparator bus for that column at any one time. The output on the comparator bus can drive into the digital blocks, and is also available to be read in the Analog Comparator Control Register (CMP_CR, Address = Bank 0,64H).

The comparator bus is latched before it is available to either drive the digital blocks, or be read in the Analog Comparator Control Register. The latch for each comparator bus is transparent (the output tracks the input) during the high period of PHI2. During the low period of PHI2 the latch retains the value on the comparator bus during the high to low transition of PHI2.

The output from the analog block that is actively driving the bus may also be latched internal to the analog block itself.

In the Continuous Time analog blocks, the CPhase and CLatch bits inside the Analog Continuous Time Type A Block xx Control Register 2 determine whether the output signal on the comparator bus is latched inside the block, and if it is, which clock phase it is latched on.

In the Switched Capacitor analog blocks, the output on the comparator bus is always latched. The ClockPhase bit in the Analog SwitchCap Type A Block xx Control Register 0 or the Analog SwitchCap Type B Block xx Control Register 0 determines the phase on which this data is latched and available.

Table 77: Analog Comparator Control Register

Bit #	7	6	5	4	3	2	1	0
POR	0	0	0	0	0	0	0	0
Read/Write	R	R	R	R	RW	RW	RW	RW
Bit Name	COMP 3	COMP 2	COMP 1	COMP 0	AINT 3	AINT 2	AINT 1	AINT 0
<p>Bit 7: COMP 3 COMP 3 bit [0] indicates the state of the analog comparator bus for the Analog Column x Bit 6: COMP 2 COMP 2 bit [0] indicates the state of the analog comparator bus for the Analog Column x Bit 5: COMP 1 COMP 1 bit [0] indicates the state of the analog comparator bus for the Analog Column x Bit 4: COMP 0 COMP 0 bit [0] indicates the state of the analog comparator bus for the Analog Column x</p> <p>Bit 3: AINT 3 AINT 3 bit [0] or [1] (as defined below) selects the Analog Interrupt Source for the Analog Column x Bit 2: AINT 2 AINT 2 bit [0] or [1] (as defined below) selects the Analog Interrupt Source for the Analog Column x Bit 1: AINT 1 AINT 1 bit [0] or [1] (as defined below) selects the Analog Interrupt Source for the Analog Column x Bit 0: AINT 0 AINT 0 bit [0] or [1] (as defined below) selects the Analog Interrupt Source for the Analog Column x</p> <p>0 = Comparator bus 1 = PHI2 (Falling edge of PHI2 causes an interrupt)</p>								

Analog Comparator Control Register (CMP_CR, Address = Bank 0, 64h)

10.11 Analog Synchronization

For high precision analog operation, it may be necessary to precisely time when updated register values are available to the analog PSoC blocks. The optimum time to update values in Switch Cap registers is at the beginning of the PHI1 active period. The SYNCEN bit in the Analog Synchronization Control Register is designed to address this. (The AINT bits of the Analog Comparator Register

(CMP_CR) are another way to address it with interrupts.) When the SYNCEN bit is set, a subsequent write instruction to any register in a Switch Cap block will cause the CPU to stall until the rising edge of PHI1. This mode is in effect until the SYNCEN bit is cleared.

The SAR hardware accelerator is a block of specialized hardware designed to sequence the SAR algorithm for efficient A/D conversion. A SAR ADC is implemented conceptually with a DAC of the desired precision, and a comparator. This functionality can be configured from one or more PSoC blocks. For each conversion, the firmware should initialize the ASY_CR register as defined below, and set the sign bit of the DAC as the first guess in the algorithm. A sequence of OR instructions (Read, Modify, Write) to the DAC (CR0) register is then executed. Each of these OR instructions causes the SAR hardware to read the current state of the comparator, checking the validity of the previous guess. It either clears it or leaves it set, accordingly. The next LSB in the DAC register is also set as the next guess. Six OR instructions will complete the conversion of a 6-bit DAC. The resulting DAC code, which matches the input voltage to within 1 LSB, is then read back from the DAC CR0 register.

10.11.1 Analog Stall and Analog Stall Lockup

Stall lockup affects the operation of stalled IO writes, such as DAC writes and the stalled IOR of the SAR hardware

accelerator. The DAC and SAR User Modules operate in this mode. The analog column clock frequency must not be a power of two multiple (2, 4, 8...) higher than the CPU clock frequency. Under this condition, the CPU will never recover from a stall.

See the list of relationships (in MHz) that will fail:

Table 78: Analog Frequency Relationships

Analog Column Clock	CPU Clock
3.	1.5, 0.75, .018, 0.093
1.5	0.75, 0.18, 0.093
0.75	0.18, 0.093
0.37	0.18, 0.093
0.18	0.093

You can still run the CPU clock slower than the column clock if the relationship is not a power of two multiple. For example, you can run at 0.6 MHz, which is not a power of two multiple of any CPU frequency and therefore any CPU frequency can be selected. If the CPU frequency is greater than or equal to the analog column clock, there is not a problem.

Table 79: Analog Synchronization Control Register

Bit #	7	6	5	4	3	2	1	0
POR	0	0	0	0	0	0	0	0
Read/Write	--	W	W	W	RW	RW	RW	RW
Bit Name	Reserved	SARCOUNT [2]	SARCOUNT [1]	SARCOUNT [0]	SAR-SIGN	SARCOL [1]	SARCOL [0]	SYNCEN

Bit 7: Reserved

Bit [6:4]: SARCOUNT [2:0] Initial SAR count. Load this field with the number of bits to process. In a typical 6-bit SAR, the value would be 6

Bit 3: SARSIGN Adjust the SAR comparator based on the type of block addressed. In a DAC configuration with more than one PSoC block (more than 6-bits), this bit would be 0 when processing the most significant block and 1 when processing the least significant block. This is because the least significant block of a DAC is an inverting input to the most significant block

Bit [2:1]: SARCOL [1:0] Column select for SAR comparator input. The DAC portion of the SAR can reside in any of the appropriate positions in the analog PSOC block array. However, once the comparator block is positioned (and it is possible to have the DAC and comparator in the same block), this should be the column selected

Bit 0: SYNCEN Set to 1, will stall the CPU until the rising edge of PHI1, if a write to a register within an analog Switch Cap block takes place

Analog Synchronization Control Register (ASY_CR, Address = Bank 0, 65h)

10.12 Analog I/O

10.12.1 Analog Input Muxing

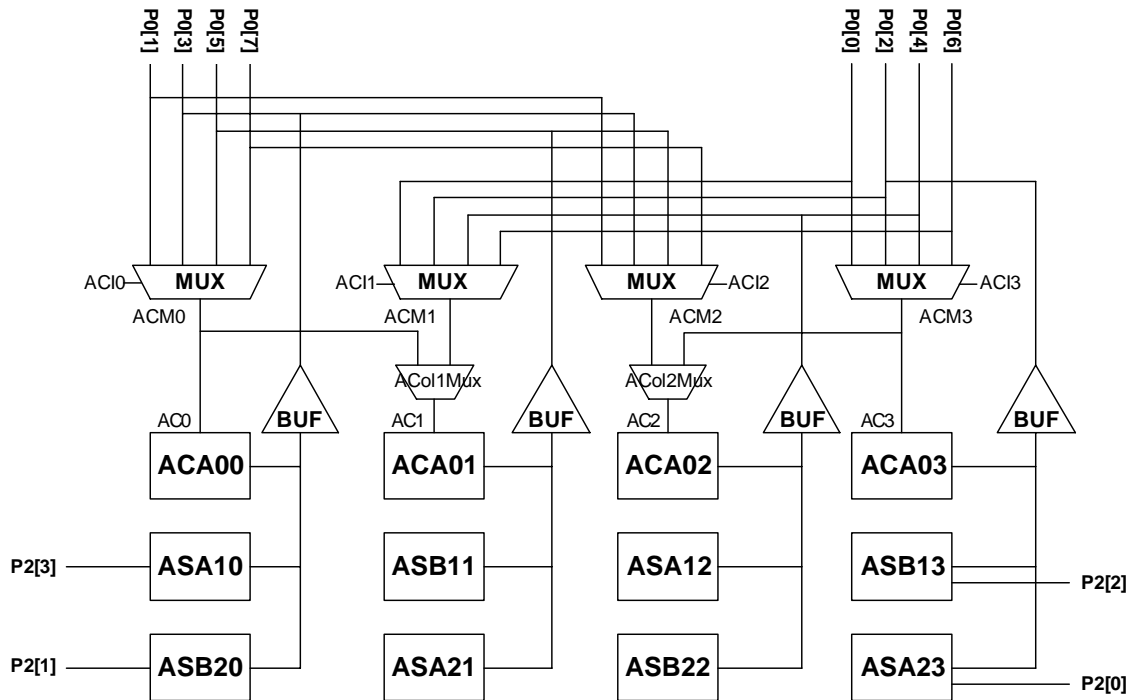

Figure 27: Analog Input Muxing

10.12.2 Analog Input Select Register

This register controls the analog muxes that feed signals in from port pins into each Analog Column. Each of the Analog Columns can have up to four port bits connected to its muxed input. Analog Columns 01 and 02 (ACI1 and ACI2) have additional muxes that allow selection between separate column multiplexers (see Analog Input Muxing diagram above). The AC1Mux and AC2Mux bit fields control the bits for those muxes and are located in the Analog Output Buffer Control Register (ABF_CR). There are four additional analog inputs that go directly into the Switch Capacitor PSoC blocks.

Table 80: Analog Input Select Register

Bit #	7	6	5	4	3	2	1	0
POR	0	0	0	0	0	0	0	0
Read/ Write	RW	RW	RW	RW	RW	RW	RW	RW
Bit Name	ACI3 [1]	ACI3 [0]	ACI2 [1]	ACI2 [0]	ACI1 [1]	ACI1 [0]	ACI0 [1]	ACI0 [0]
<p>Bit [7:6]: ACI3 [1:0] 0 0 = ACM3 P0[0] 0 1 = ACM3 P0[2] 1 0 = ACM3 P0[4] 1 1 = ACM3 P0[6]</p> <p>Bit [5:4]: ACI2 [1:0] 0 0 = ACM2 P0[1] 0 1 = ACM2 P0[3] 1 0 = ACM2 P0[5] 1 1 = ACM2 P0[7] ACol2Mux (ABF_CR, Address = Bank1, 62h) 0 = AC2 = ACM2 1 = AC2 = ACM3</p> <p>Bit [3:2]: ACI1 [1:0] 0 0 = ACM1 P0[0] 0 1 = ACM1 P0[2] 1 0 = ACM1 P0[4] 1 1 = ACM1 P0[6] ACol1Mux (ABF_CR, Address = Bank1, 62h) 0 = AC1 = ACM1 1 = AC1 = ACM0</p> <p>Bit [1:0]: ACI0 [1:0] 0 0 = ACM0 P0[1] 0 1 = ACM0 P0[3] 1 0 = ACM0 P0[5] 1 1 = ACM0 P0[7]</p>								

Analog Input Select Register (AMX_IN, Address = Bank 0, 60h)

10.12.3 Analog Output Buffers

The user has the option to output up to four analog signals on the pins of the device. This is done by enabling the analog output buffers associated with each Analog

Column. The enable bits for the analog output buffers are contained in the Analog Output Buffer Control Register (ABF_CR).

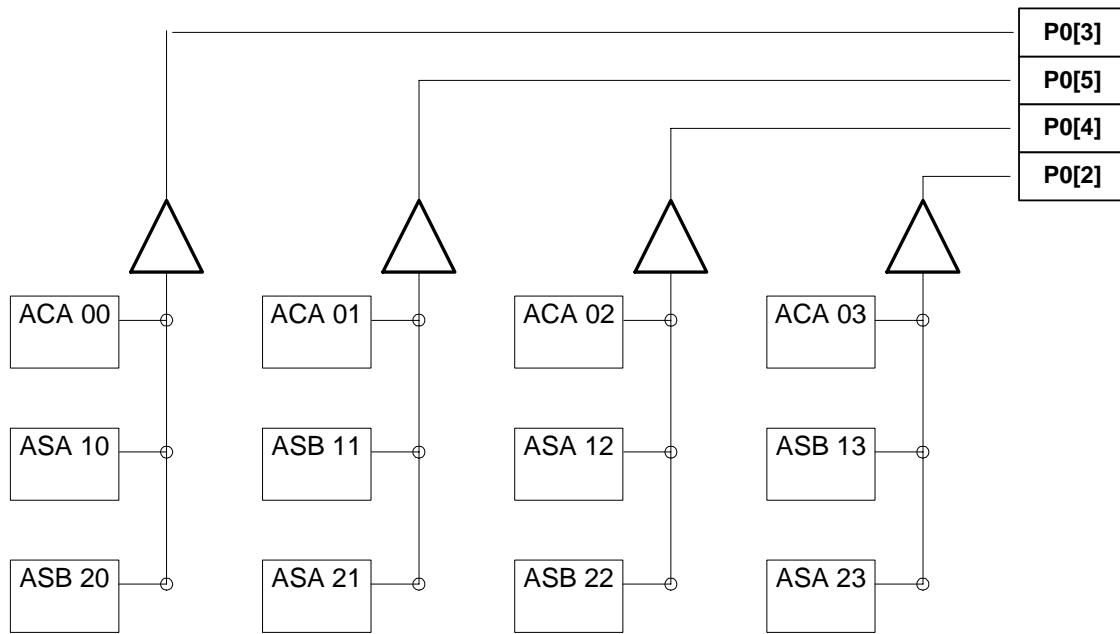

Figure 28: Analog Output Buffers

10.12.4 Analog Output Buffer Control Register

Table 81: Analog Output Buffer Control Register

Bit #	7	6	5	4	3	2	1	0
POR	0	0	0	0	0	0	0	0
Read/ Write	W	W	W	W	W	W	--	W
Bit Name	ACol1Mux	ACol2Mux	ABUF1EN	ABUF2EN	ABUF0EN	ABUF3EN	Reserved	PWR

Bit 7: ACol1Mux

0 = Set column 1 input to column 1 input mux output
1 = Set column 1 input to column 0 input mux output

Bit 6: ACol2Mux

0 = Set column 2 input to column 2 input mux output
1 = Set column 2 input to column 3 input mux output

Bit 5: ABUF1EN Enables the analog output buffer for Analog Column 1 (Pin P0[5])

0 = Disable analog output buffer
1 = Enable analog output buffer

Bit 4: ABUF2EN Enables the analog output buffer for Analog Column 2 (Pin P0[4])

0 = Disable analog output buffer
1 = Enable analog output buffer

Bit 3: ABUF0EN Enables the analog output buffer for Analog Column 0 (Pin P0[3])

0 = Disable analog output buffer
1 = Enable analog output buffer

Bit 2: ABUF3EN Enables the analog output buffer for Analog Column 3 (Pin P0[2])

0 = Disable analog output buffer
1 = Enable analog output buffer

Bit [1]: Reserved Must be left as 0

Bit [0]: PWR Determines power level of all output buffers

0 = Low output power
1 = High output power

Analog Output Buffer Control Register (ABF_CR, Address = Bank 1, 62h)

10.13 Analog Modulator

The user has the capability to use the Analog Switch Cap Type A PSoC Blocks in Columns 0 and 2 as amplitude modulators. The Analog Modulator Control Register (AMD_CR) allows the user to select the appropriate modulating signal. When the modulating signal is low, the polarity follows the setting of the ASign bit set in the Analog Switch Cap Type A Control 0 Register (ASAxCR0). When this signal is high, the normal gain polarity of the PSoC block is inverted.

Table 82: Analog Modulator Control Register

Bit #	7	6	5	4	3	2	1	0
POR	0	0	0	0	0	0	0	0
Read/Write	RW	RW	RW	RW	RW	RW	RW	RW
Bit Name	Reserved	Reserved	Reserved	Reserved	AMOD2[1]	AMOD2[0]	AMOD0[1]	AMOD0[0]

Bit 7: Reserved
Bit 6: Reserved
Bit 5: Reserved
Bit 4: Reserved

Bit [3:2]: AMOD2[1], AMOD2[0] Selects the modulation signal for Analog Column 2
0 0 = No Modulation
0 1 = Global Output [0]
1 0 = Global Output [4]
1 1 = Digital Basic Type A Block 03

Bit [1:0]: AMOD0[1], AMOD0[0] Selects the modulation signal for Analog Column 0
0 0 = No Modulation
0 1 = Global Output [0]
1 0 = Global Output [4]
1 1 = Digital Basic Type A Block 03

Analog Modulator Control Register (AMD_CR, Address = Bank 1, 63h)

10.14 Analog PSoC Block Functionality

The analog PSoC blocks can be used to implement a wide range of functions, limited only by the designer's imagination. The following functions operate within the capability of the analog PSoC blocks using one analog PSoC block, multiple analog blocks, a combination of more than one *type* of analog block, or a combination of analog and digital PSoC blocks. Most of these functions are currently available as User Modules in PSoC Designer. Others will be added in the future.

- Delta-Sigma A/D Converters
- Successive Approximation A/D Converters
- Incremental A/D Converters
- Programmable Gain/Loss Stage
- Analog Comparators
- Zero-Crossing Detectors
- Low-Pass Filter
- Band-Pass Filter
- Notch Filter

- Amplitude Modulators
- Amplitude Demodulators
- Sine-Wave Generators
- Sine-Wave Detectors
- Sideband Detection
- Sideband Stripping
- Audio Output Drive
- DTMF Generator
- FSK Modulator

By modifying registers, as described in this Data Sheet, users can configure PSoC blocks to perform these functions and more.

10.15 Temperature Sensing Capability

A temperature-sensitive voltage derived from the Band Gap sensing on the die is buffered and available as an analog input into the Analog Switch Cap Type A Block ASA21. Temperature sensing allows protection of device operating ranges for fail-safe applications. Temperature sensing combined with a long sleep timer interval (to allow the die to approximate ambient temperature) can give an approximate ambient temperature for data acquisition and battery charging applications. The user may also calibrate the internal temperature rise based on a known current consumption.

The temperature sensor input to the ASA21 block is labeled VTemp, and its associated ground reference is labeled TRefGND (see [Figure 22](#); [Figure 24](#)).

11.0 Special Features of the CPU

11.1 Multiplier/Accumulator

A fast, on-chip signed 2's complement MAC (Multiply/Accumulate) function is provided to assist the main CPU with digital signal processing applications. Multiply results, as well as the lower 2 bytes of the Accumulator, are available immediately after the input registers are written. The upper 2 bytes require a single instruction delay before reading. The MAC function is tied directly on the internal data bus, and is mapped into the register space. The following MAC block diagram provides data flow information. The user has the choice to either cause a multiply/accumulate function to take place, or a multiply only function. The user selects which operation is performed by the choice of input register. The multiply function occurs immediately whenever the MUL_X or the MUL_Y multiplier input registers are written, and the result is available in the MUL_DH and MUL_DL multiplier result registers. The Multiply/Accumulate function is executed whenever there is a write to the MAC_X or the MAC_Y Multiply/Accumulate input registers, and the result is available in the ACC_DR3, ACC_DR2, ACC_DR1, and ACC_DR0 accumulator result registers. A write to MUL_X or MAC_X is input as the X value to both the multiply and Multiply/Accumulate functions. A write to MUL_Y or MAC_Y is input as the Y value to both the multiply and Multiply/Accumulate functions. A write to the MAC_CL0 or MAC_CL1 registers will clear the value in the four accumulate registers.

Operation of the Multiply/Accumulate function relies on proper multiplicand input. The first value of each multiplicand must be placed into MUL_X (or MUL_Y) register to avoid causing a Multiply/Accumulate to occur. The second multiplicand must be placed into MAC_Y (or MAC_X) thereby triggering the Multiply/Accumulate function.

MUL_X, MUL_Y, MAC_X, and MAC_Y are 8-bit signed input registers. MUL_DL and MUL_DH form a 16-bit signed output. ACC_DR0, ACC_DR1, ACC_DR2 and ACC_DR3 form a 32-bit signed output.

An extra instruction must be inserted between the following sequences of MAC operations to provide extra delay. If this is not done, the Accumulator results will be inaccurate.

- a. Two MAC instructions in succession:

```
mov reg[MAC_X],a
nop //add nop or any other instruction
mov reg[MAC_X],a
```

For sequence a., there is no workaround, the nop or other instruction must be inserted.

- b. A MAC instruction followed by a read of the most significant Accumulator bytes:

```
mov reg[MAC_X],a
nop //add nop or any other instruction
mov a,[ACC_DR2] // or ACC_DR3
```

For sequence b., the least significant Accumulator bytes (ACC_DR0, ACC_DR1) may be reliably read directly after the MAC instruction.

Writing to the multiplier registers (MUL_X, MUL_Y), and reading the result back from the multiplier product registers (MUL_DH, MUL_DL), is not affected by this problem and does not have any restrictions.

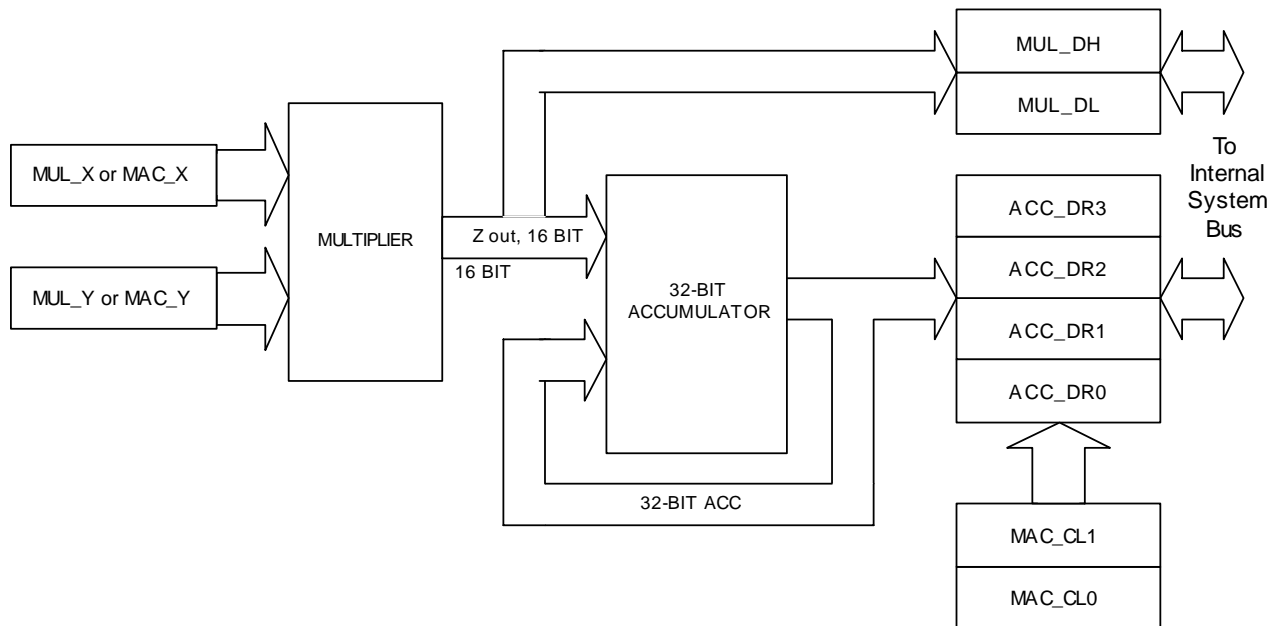

Figure 29: Multiply/Accumulate Block Diagram

Table 83: Multiply Input X Register

Bit #	7	6	5	4	3	2	1	0
POR	0	0	0	0	0	0	0	0
Read/Write	W	W	W	W	W	W	W	W
Name	Data [7]	Data [6]	Data [5]	Data [4]	Data [3]	Data [2]	Data [1]	Data [0]
Bit [7:0]: Data [7:0] 8-bit data is the input value for X multiplier								

Multiply Input X Register (MUL_X, Address = Bank 0, E8h)

Table 84: Multiply Input Y Register

Bit #	7	6	5	4	3	2	1	0
POR	0	0	0	0	0	0	0	0
Read/Write	W	W	W	W	W	W	W	W
Bit Name	Data [7]	Data [6]	Data [5]	Data [4]	Data [3]	Data [2]	Data [1]	Data [0]
Bit [7:0]: Data [7:0] 8-bit data is the input value for Y multiplier								

Multiply Input Y Register (MUL_Y, Address = Bank 0, E9h)

Table 85: Multiply Result High Register

Bit #	7	6	5	4	3	2	1	0
POR	0	0	0	0	0	0	0	0
Read/Write	R	R	R	R	R	R	R	R
Bit Name	Data [7]	Data [6]	Data [5]	Data [4]	Data [3]	Data [2]	Data [1]	Data [0]
Bit [7:0]: <u>Data [7:0]</u> 8-bit data value is the high order result of the multiply function								

Multiply Result High Register (MUL_DH, Address = Bank 0, EAh)

Table 86: Multiply Result Low Register

Bit #	7	6	5	4	3	2	1	0
POR	0	0	0	0	0	0	0	0
Read/Write	R	R	R	R	R	R	R	R
Bit Name	Data [7]	Data [6]	Data [5]	Data [4]	Data [3]	Data [2]	Data [1]	Data [0]
Bit [7:0]: <u>Data [7:0]</u> 8-bit data value is the low order result of the multiply function								

Multiply Result Low Register (MUL_DL, Address = Bank 0, EBh)

Table 87: Accumulator Result 1 / Multiply/Accumulator Input X Register

Bit #	7	6	5	4	3	2	1	0
POR	0	0	0	0	0	0	0	0
Read/Write	RW	RW	RW	RW	RW	RW	RW	RW
Bit Name	Data [7]	Data [6]	Data [5]	Data [4]	Data [3]	Data [2]	Data [1]	Data [0]
Bit [7:0]: <u>Data [7:0]</u> 8-bit data value when read is the next to lowest order result of the multiply/accumulate function 8-bit data value when written is the X multiplier input to the multiply/accumulate function								

Accumulator Result 1 / Multiply/Accumulator Input X Register (ACC_DR1 / MAC_X, Address = Bank 0, ECh)

Table 88: Accumulator Result 0 / Multiply/Accumulator Input Y Register

Bit #	7	6	5	4	3	2	1	0
POR	0	0	0	0	0	0	0	0
Read/Write	RW	RW	RW	RW	RW	RW	RW	RW
Bit Name	Data [7]	Data [6]	Data [5]	Data [4]	Data [3]	Data [2]	Data [1]	Data [0]
Bit [7:0]: <u>Data [7:0]</u> 8-bit data value when read is the lowest order result of the multiply/accumulate function 8-bit data value when written is the Y multiplier input to the multiply/accumulate function								

Accumulator Result 0 / Multiply/Accumulator Input Y Register (ACC_DR0 / MAC_Y, Address = Bank 0, EDh)

Table 89: Accumulator Result 3 / Multiply/Accumulator Clear 0 Register

Bit #	7	6	5	4	3	2	1	0
POR	0	0	0	0	0	0	0	0
Read/Write	RW	RW	RW	RW	RW	RW	RW	RW
Bit Name	Data [7]	Data [6]	Data [5]	Data [4]	Data [3]	Data [2]	Data [1]	Data [0]

Bit [7:0]: Data [7:0]
8-bit data value when read is the highest order result of the multiply/accumulate function
Any 8-bit data value when written will cause all four Accumulator result registers to clear

Accumulator Result 3 / Multiply/Accumulator Clear 0 Register (ACC_DR3 / MAC_CL0, Address = Bank 0, EEh)

Table 90: Accumulator Result 2 / Multiply/Accumulator Clear 1 Register

Bit #	7	6	5	4	3	2	1	0
POR	0	0	0	0	0	0	0	0
Read/Write	RW	RW	RW	RW	RW	RW	RW	RW
Bit Name	Data [7]	Data [6]	Data [5]	Data [4]	Data [3]	Data [2]	Data [1]	Data [0]

Bit [7:0]: Data [7:0]
8-bit data value when read is next to highest order result of the multiply/accumulate function
Any 8-bit data value when written will cause all four Accumulator result registers to clear

Accumulator Result 2 / Multiply/Accumulator Clear 1 Register (ACC_DR2 / MAC_CL1, Address = Bank 0, EFh)

11.2 Decimator

The output of a Δ - Σ modulator is a high-speed, single bit A/D converter. A single bit A/D converter is of little use to anyone and must be converted to a lower speed multiple bit output. Converting this high-speed single bit data stream to a lower speed multiple bit data stream requires a data decimator.

A “divide by n” decimator is a digital filter that takes the single bit data at a fast rate and outputs multiple bits at one n^{th} the speed. For a single stage Δ - Σ converter, the optimal filter has a sinc^2 response. This filter can be implemented as a finite impulse response (FIR) filter and for a “divide by n” implementation should have the following coefficients:

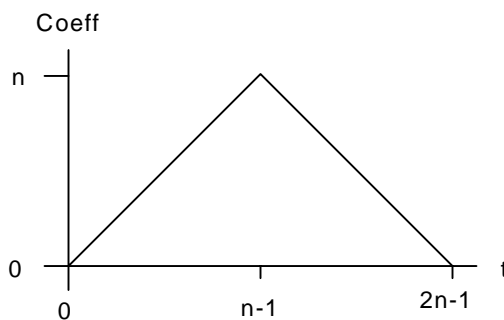
**Figure 30: Decimator Coefficients**

This filter is implemented using a combination of hardware and software resources. Hardware is used to accumulate the high-speed in-coming data while the software

is used to process the lower speed, enhanced resolution data for output.

Table 91: Decimator/Incremental Control Register

Bit #	7	6	5	4	3	2	1	0
POR	0	0	0	0	0	0	0	0
Read/Write	RW	RW	RW	RW	RW	RW	RW	RW
Bit Name	IGEN [3]	IGEN [2]	IGEN [1]	IGEN [0]	ICCKSEL	DCol [1]	DCol [0]	DCLKSEL

Bit [7:4]: IGEN [3:0] Individual enables for each analog column that gates the Analog Comparator based on the ICCKSEL input (Bit 3)

Bit 3: ICCKSEL Clock select for Incremental gate function
 0 = Digital Basic Type A Block 02
 1 = Digital Communications Type A Block 06

Bit [2:1]: DCol [1:0] Selects Analog Column Comparator source
 0 0 = Analog Column Comparator 0
 0 1 = Analog Column Comparator 1
 1 0 = Analog Column Comparator 2
 1 1 = Analog Column Comparator 3

Bit 0: DCLKSEL Clock select for Decimator latch
 0 = Digital Basic Type A Block 02
 1 = Digital Communications Type A Block 06

Decimator Incremental Register (DEC_CR, Address = Bank 0, E6h)

Table 92: Decimator Data High Register

Bit #	7	6	5	4	3	2	1	0
POR	0	0	0	0	0	0	0	0
Read/Write	RW	RW	RW	RW	RW	RW	RW	RW
Bit Name	Data [7]	Data [6]	Data [5]	Data [4]	Data [3]	Data [2]	Data [1]	Data [0]

Bit [7:0]: Data [7:0]
 8-bit data value when read is the high order byte within the 16-bit decimator data registers
 Any 8-bit data value when written will cause both the Decimator Data High (DEC_DH) and Decimator Data Low (DEC_DL) registers to be cleared

Decimator High Register (DEC_DH / DEC_CL, Address = Bank 0, E4h)

Table 93: Decimator Data Low Register

Bit #	7	6	5	4	3	2	1	0
POR	0	0	0	0	0	0	0	0
Read/Write	R	R	R	R	R	R	R	R
Bit Name	Data [7]	Data [6]	Data [5]	Data [4]	Data [3]	Data [2]	Data [1]	Data [0]

Bit [7:0]: Data [7:0]
 8-bit data value when read is the low order byte within the 16 bit decimator data registers

Decimator Data Low Register (DEC_DL, Address = Bank 0, E5h)

11.3 Reset

11.3.1 Overview

The microcontroller supports two types of resets. When reset is initiated, all registers are restored to their default states and all interrupts are disabled.

Reset Types: Power On Reset (POR), External Reset (X_{res}), and Watchdog Reset (WDR).

The occurrence of a reset is recorded in the Status and Control Register (CPU_SCR). Bits within this register record the occurrence of POR and WDR Reset respec-

tively. The firmware can interrogate these bits to determine the cause of a reset.

The microcontroller resumes execution from ROM address 0x0000 after a reset. The internal clocking mode is active after a reset, until changed by user firmware. In addition, the Sleep / Watchdog Timer is reset to its minimum interval count.

Important: The CPU clock defaults to divide by 8 mode at POR to guarantee operation at the low V_{cc} that might be present during the supply ramp.

Table 94: Processor Status and Control Register

Bit #	7	6	5	4	3	2	1	0
POR	0	0	0	1	0	0	0	0
Read/ Write	R	--	R/C ¹	R/C ¹	RW	--	--	RW
Bit Name	IES	Reserved	WDRS	PORS	Sleep	Reserved	Reserved	Stop

Bit 7: IES Global interrupt enable status from CPU Flag register

0 = Global interrupts disabled

1 = Global interrupts enabled

Bit 6: Reserved

Bit 5: WDRS

WDRS is set by the CPU to indicate that a Watchdog Reset event has occurred. The user can read this bit to determine the type of reset that has occurred. The user can clear but not set this bit

0 = No WDR

1 = A WDR event has occurred

Bit 4: PORS

PORS is set by the CPU to indicate that a Power On Reset event has occurred. The user can read this bit to determine the type of reset that has occurred. The user can clear but not set this bit

0 = No POR

1 = A POR event has occurred. (Note that WDR events will not occur until this bit is cleared)

Bit 3: Sleep Set by the user to enable CPU sleep state. CPU will remain in sleep mode until any interrupt is pending

0 = Normal operation

1 = Sleep

Bit 2: Reserved

Bit 1: Reserved

Bit 0: Stop Set by the user to halt the CPU. The CPU will remain halted until a reset (WDR or POR) has taken place

0 = Normal CPU operation

1 = CPU is halted (not recommended)

1. C = Clear

Status and Control Register (CPU_SCR, Address = Bank 0/1, FFh)

11.3.2 Power On Reset (POR)

Power On Reset (POR) occurs every time the power to the device is switched on. POR is released when the supply is typically 2.2V +/-12% for the upward supply transition, with typically 120mV of hysteresis during the power on transient. Bit 4 of the Status and Control Register (CPU_SCR) is set to record this event (the register contents are set to 00010000 by the POR). After a POR, the microprocessor is suspended for 64 ms. This provides time for the Vcc supply to stabilize after the POR

trip, before CPU operation begins. If the Vcc voltage drops below the POR downward supply trip point (2.1V +/-12%, once the internal reference is established), POR is reasserted.

Important: The PORS status bit is set at POR and can only be cleared by the user, and cannot be set by firmware.

11.3.3 Execution Reset

The following diagram illustrates the sequence of events (in time) for execution reset, from voltage stabilization on through execution of user's code. Once voltage trips POR and after 64 ms, the CPU starts boot calibration. Boot calibration takes 2,502 cycles, with the CPU running at 3 MHz. This results in approximately 800 μ s for

the time between beginning boot calibration and reset vector. At reset vector, the boot.asm must execute before user code begins running. (boot.asm contains device configurations from PSoC Designer. The time it takes boot.asm to execute varies depending on device configuration settings such as CPU speed.)

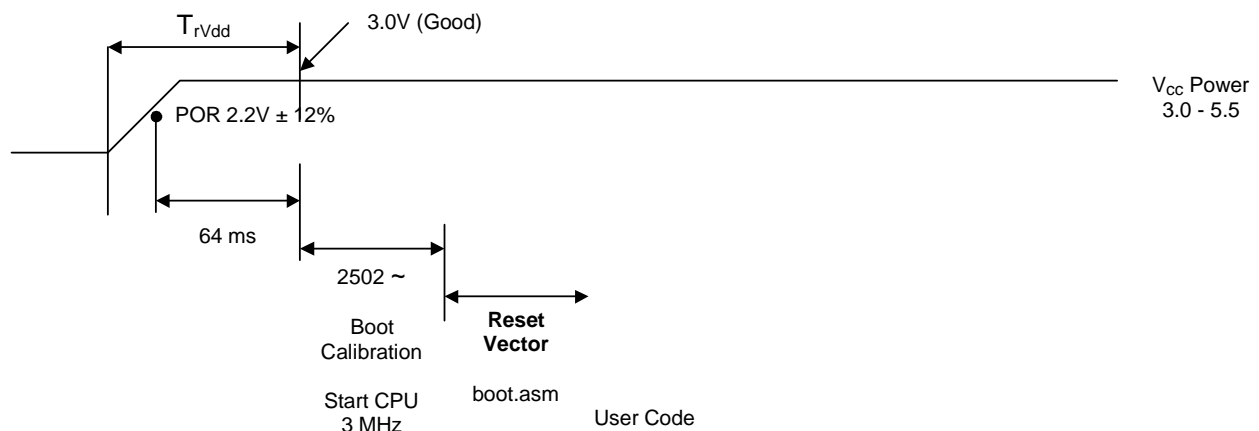

Figure 31: Execution Reset

11.3.4 External Reset (X_{res})

Pulling the X_{res} pin high for a minimum of 10 μ s forces the microcontroller to perform a Power On Reset (POR). The X_{res} pin does not require a pull-down resistor for operation and can be tied directly to ground, or left open.

The only exception to this is if a POR event takes place, which will disable the WDT.

11.3.5 Watchdog Timer Reset (WDR)

The user has the option to enable the WDT. The WDT is enabled by clearing the PORS bit. Once the PORS bit is cleared, the Watchdog Timer (WDT) cannot be disabled.

The sleep timer is used to generate the sleep time period and the watchdog time period. The sleep timer divides down the **32K** system clock, and thereby produces the sleep time period. The user can program the sleep time period to be one of 4 multiples of the period of the **32K** clock. When the sleep time elapses (sleep timer overflows), an interrupt to the Sleep Timer Interrupt Vector will be generated.

The Watchdog Timer period is automatically set to be 3 counts of the Sleep Timer overflows. This represents between two and three sleep intervals depending on the count in the Sleep Timer at the previous WDT clear. When this timer reaches 3, a WDR is generated.

The user can either clear the WDT, or the WDT and the Sleep Timer. Whenever the user writes to the Reset WDT Register (RES_WDT), the WDT will be cleared. If the data that is written is the hex value 38H, the Sleep Timer will also be cleared at the same time.

This timer chain is also used to time the startup for the external 32 kHz crystal oscillator. When selecting the external 32 kHz oscillator, a value of 1 second must be selected as the sleep interval. When the sleep interrupt occurs, the 32 kHz oscillator source will switch from internal to the crystal. The device does not have to be put into sleep for this event to occur. Note that if too short of a sleep interval is given, the crystal oscillator will not be stable prior to switch over and the results will be unpredictable.

Table 95: Reset WDT Register

Bit #	7	6	5	4	3	2	1	0
POR	0	0	0	0	0	0	0	0
Read/Write	W	W	W	W	W	W	W	W
Bit Name	Data [7]	Data [6]	Data [5]	Data [4]	Data [3]	Data [2]	Data [1]	Data [0]
Bit [7:0]: <u>Data [7:0]</u> Any write to this register will clear Watchdog Timer, a write of 38h will also clear the Sleep Timer								

Reset WDT Register (RES_WDT, Address = Bank 0, E3h)

11.4 Sleep States

There are three sleep states that can be used to lower the overall power consumption on the device. The three states are CPU Sleep, Analog Sleep, and Full Sleep.

The CPU can only be put to sleep by the firmware. This is accomplished by setting the Sleep Bit in the Status and Control Register (CPU_SCR). This stops the CPU from executing instructions, and the CPU will remain asleep until an interrupt comes pending, or there is a reset event (either a Power On Reset, or a Watchdog Timer Reset). While in the CPU Sleep state, all clocking signals derived from the Internal Main Oscillator are inactivated, including the **48M**, **24M**, **24V1**, and **24V2** system clocking signals. The Internal Low Speed Oscillator will continue to operate during the CPU Sleep state. The function of any analog or digital PSoC block that is clocked from these system-clocking signals will stop during the CPU Sleep state.

The user can also put all the analog PSoC block circuits to sleep. This is accomplished by resetting the Analog Array Power Control bits in the Analog Reference Control Register (ARF_CR), which overrides the individual

enable bits within each analog PSoC block. Setting the Analog Array Power Control bits will restore the function to those analog PSoC blocks that were previously in use. The user should take into account the required settling time after an analog PSoC block is enabled before it will provide the maximum precision.

For greatest power savings, the user should put the device in the Full Sleep state. This is accomplished by first transitioning to the Analog Sleep state, and then setting the Sleep Bit in the CPU_SCR Register to the Full Sleep state. The CPU will be stopped at this point, and either an interrupt or reset event is required to transition back to the Analog Sleep state.

The Voltage Reference and Supply Voltage Monitor drop into (fully functional) power-reduced states. All interrupts remain active. The Internal Low Speed Oscillator remains running (it will however drop into a less accurate, low-power state). If enabled, the External Crystal Oscillator will continue running throughout sleep (the Internal Low Speed Oscillator is disabled if the External Crystal Oscillator is selected). Only the occurrence of an

interrupt will wake the part from sleep. The Stop bit in the Status and Control Register (CPU_SCR) must be cleared for a part to resume out of sleep.

Any digital PSoC block that is clocked by a System Clock other than the **32K** system-clocking signal or external pins will be stopped, as these clocks do not run in sleep mode.

The Internal Main Oscillator restarts immediately on exiting either the Full Sleep or CPU Sleep modes. Analog functions must be re-enabled by firmware. If the External Crystal Oscillator is used and the internal PLL is enabled, the PLL will take many cycles to change from its initial 2.5% accuracy to track that of the External Crystal Oscillator. If the PLL is enabled, there will be a 30 μ s (one full **32K** cycle) delay hold-off time for the CPU to let the VCO and PLL stabilize. If the PLL is not enabled, the hold-off time is one half of the **32K** cycle. For further details on PLL, see 7.0.

The Sleep interrupt allows the microcontroller to wake up periodically and poll system components while maintaining very low average power consumption. The sleep interrupt may also be used to provide periodic interrupts during non-sleep modes.

In System Sleep State, GPIO Pins P2[4] and P2[6] should be held to a logic low or a false Low Voltage Detect interrupt may be triggered. The cause is in the System Sleep State, the internal Bandgap reference generator is turned off and the reference voltage is maintained on a capacitor.

The circumstances are that during sleep, the reference voltage on the capacitor is refreshed periodically at the sleep system duty cycle. Between refresh cycles, this voltage may leak slightly to either the positive supply or ground. If pins P2[4] or P2[6] are in a high state, the leakage to the positive supply is accelerated (especially at high temperature). Since the reference voltage is compared to the supply to detect a low voltage condition, this accelerated leakage to the positive supply voltage will cause that voltage to appear lower than it actually is, leading to the generation of a false Low Voltage Detect interrupt.

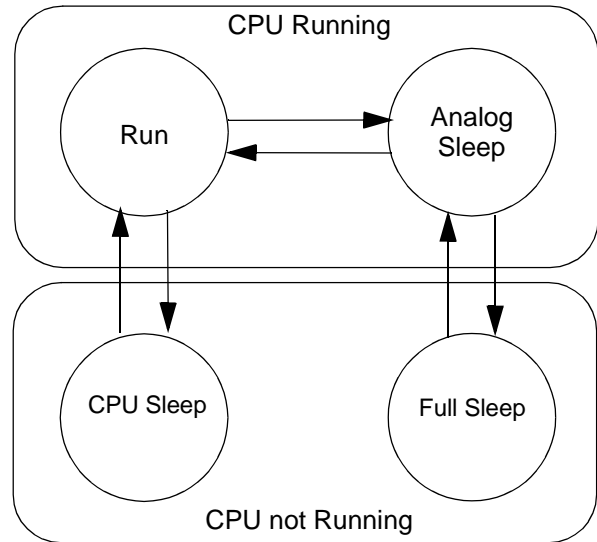

Figure 32: Three Sleep States

11.5 Supply Voltage Monitor

The Supply Voltage Monitor detector generates an interrupt whenever Vcc drops below a pre-programmed value. There are eight voltage trip points that are selectable by setting the VM [2:0] bit in the Voltage Monitor

Control Register (VLT_CR). These bits also select the Switch Mode Pump trip points. The Supply Voltage Monitor will remain active when the device enters sleep mode.

Table 96: Voltage Monitor Control Register

Bit #	7	6	5	4	3	2	1	0
POR	0	0	0	0	0	0	0	0
Read/Write	W	--	--	--	--	W	W	W
Bit Name	SMP	Reserved	Reserved	Reserved	Reserved	VM [2]	VM [1]	VM [0]

Bit 7: SMP Disables SMP function
0 = Switch Mode Pump enabled, default
1 = Switch Mode Pump disabled

Bit 6: Reserved
Bit 5: Reserved
Bit 4: Reserved
Bit 3: Reserved

Bit [2:0]: VM [2:0]

<u>Low Voltage Detection</u>	<u>Switch Mode Pump</u>
0 0 0 = 2.95 Trip Voltage ¹	0 0 0 = 3.17 Trip Voltage
0 0 1 = 3.02 Trip Voltage	0 0 1 = 3.25 Trip Voltage
0 1 0 = 3.17 Trip Voltage	0 1 0 = 3.42 Trip Voltage
0 1 1 = 3.71 Trip Voltage	0 1 1 = 3.94 Trip Voltage
1 0 0 = 4.00 Trip Voltage	1 0 0 = 4.19 Trip Voltage
1 0 1 = 4.48 Trip Voltage	1 0 1 = 4.64 Trip Voltage
1 1 0 = 4.56 Trip Voltage	1 1 0 = 4.82 Trip Voltage
1 1 1 = 4.64 Trip Voltage	1 1 1 = 5.00 Trip Voltage

1. Voltages are ideal typical values. Tolerances are in [Table 104 on page 129](#).

Voltage Monitor Control Register (VLT_CR, Address = Bank 1, E3h)

11.6 Switch Mode Pump

This feature is available on the CY8C26xxx versions within this family. During the time V_{CC} is ramping from 0 Volts to POR V_{trip} (2.2V +/- 12%), IC operation is held off by the POR circuit and the Switch Mode Pump is enabled. The pump is realized by connecting an external inductor between the battery voltage and SMP, with an external diode pointing from SMP to the V_{CC} pin (which must have a bypass capacitance of at least 0.1uF connected to V_{CC}). This circuitry will pump V_{CC} to the Switch Mode Pump value specified in the Voltage Monitor Control Register (VLT_CR), shown above. Battery voltage values down to 0.9 V during operation are supported, but this circuitry is not guaranteed to start for battery voltages below 1.2 V. Once the IC is enabled after its power

up and boot sequence, firmware can disable the SMP function by writing Voltage Monitor Control Register (VLT_CR) bit 7 to a 1.

When the IC is put into sleep mode, the power supply pump will remain running to maintain voltage. This may result in higher than specification sleep current depending upon application. If the user desires, the pump may be disabled during precision measurements (such as A/D conversions) and then re-enabled (writing B7 to 1 and then back to 0 again). The user, however, is responsible for making the operation happen quickly enough to guarantee supply holdup (by the bypass capacitor) sufficient for continued operation.

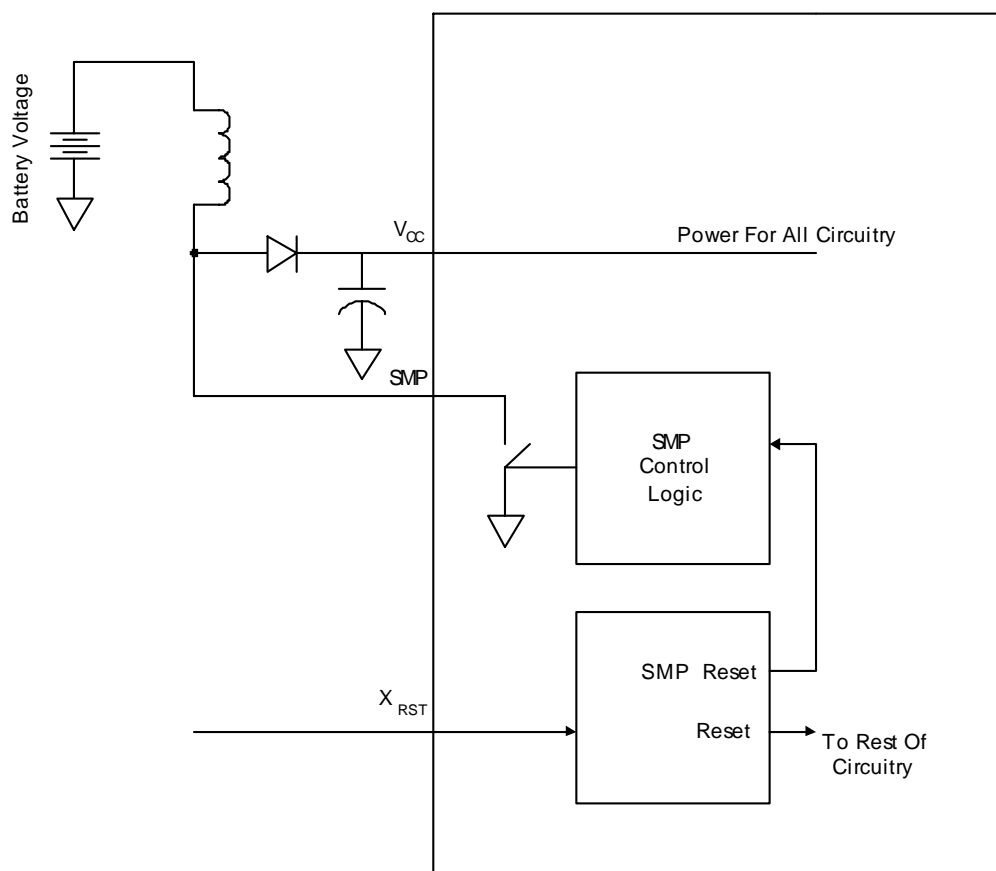

Figure 33: Switch Mode Pump

11.7 Internal Voltage Reference

An internal bandgap voltage reference source is provided on-chip. This reference is used for the Supply Voltage Monitor, and can also be accessed by the user as a reference voltage for analog operations. There is a Bandgap Oscillator Trim Register (BDG_TR) used to calibrate this reference into specified tolerance. Factory-programmed trim values are available for 5.0V and 3.3V

operation. The 5.0V value is loaded in the BDG_TR register upon reset. This register must be adjusted when operating voltage outside the range for which factory calibration was set. Changing the factory-programmed trim value is done using the Table Read Supervisor Call routine, and is documented in 11.8.

Table 97: Bandgap Trim Register

Bit #	7	6	5	4	3	2	1	0
POR	FS ¹	FS ¹	FS ¹	FS ¹	FS ¹	FS ¹	FS ¹	FS ¹
Read/Write	W	W	W	W	W	W	W	W
Bit Name	FMRD	BGT[2]	BGT[1]	BGT[0]	BGO[3]	BGO[2]	BGO[1]	BGO[0]

Bit 7: FMRD
 0 = Enable voltage divider between BG and Flash (User must not use other than this setting)
 1 = Disable voltage divider between BG and Flash (Test purposes only)

Bit [6:4]: BGT [2:0] Provides Temperature Curve compensation

Bit [3:0]: BGO [3:0] Provides +/- 5% Offset Trim to center V_{bg} to 1.30V

1. FS = Factory set trim value

Bandgap Trim Register (BDG_TR, Address = Bank 1, EAh)

11.8 Supervisor ROM/System Supervisor Call Instruction

The parts in this family have a Supervisor ROM to manage the programming, erasure, and protection of the on-chip Flash user program space. The Supervisor ROM also gives the user the capability to read the internal product ID, access factory trim values, as well as calculate checksums on blocks of the Flash memory space.

The System Supervisor Call instruction (SSC, opcode/byte 00h) provides the method for the user to access the pre-existing routines in the Supervisor ROM to implement these functions. This instruction sets the Flags Register (CPU_F) bit 3 to 1 and performs an interrupt to address 0000 into the Supervisory ROM. The flag and old PC are pushed onto the Stack. The fact that the flag pushed has F[3] = 1 is irrelevant as the RETI instruction always clears F[3]. The Supervisory code at 0000 does a JACC table lookup based on the Accumulator value, which is effectively another level of instruction encoding. This service table implements the vectors to the various supervisory functions. The user must set several param-

eters when utilizing these functions. The parameters are written to 5 bytes of an 8-byte block near the top of RAM memory space.

Access to these functions must be through the Flash APIs provided in PSoC Designer and described in Application Note AN2015.

The following table documents each function, as well as the required parameter values:

Table 98: CY8C25122, CY8C26233, CY8C26443, CY8C26643 (256 Bytes of SRAM)

Operation	Function	Accumulator	Input SRAM Data								Output SRAM Data							
			F8h	F9h	FAh	FBh	FCh	FDh	FEh	FFh	F8h	F9h	FAh	FBh	FCh	FDh	FEh	FFh
Reset ¹	Calibrates then sets PC and SP values to 0	00	NA	NA	NA	NA	NA	NA	NA	NA	*	*	*	*	*	*	*	
Read Block	Move block of 64 bytes of FLASH data into SRAM	01	3Ah	SP +3	Blk ID	Pointer	NA	0	0	0	0	0	*	*	*	*	*	
Write Block ²	Program block of FLASH with data from SRAM	02	3Ah	SP +3	Blk ID	Pointer	Clock	0	0	0	0	0	*	*	*	*	*	
Erase Block	Erase block of FLASH	03	3Ah	SP +3	Blk ID	NA	Clock	0	0	0	0	0	*	*	*	*	*	
Protect Block ³	Set memory protection bits ⁴	04	3Ah	SP +3	NA	NA	Clock	0	0	0	0	0	*	*	*	*	*	
Erase All ³	Erase all FLASH data	05	3Ah	SP +3	NA	NA	Clock	0	0	0	0	0	*	*	*	*	*	
Table Read	Read device type code	06	3Ah	SP +3	Tbl ID	NA	NA	NA	NA	NA	TV (0)	TV (1)	TV (2)	TV (3)	TV (4)	TV (5)	TV (6)	TV (7)
Checksum	Calculate FLASH checksum for data range specified	07	3Ah	SP +3	Blk Counter	NA	NA	0	0	0	CS H	CSL	*	*	*	*	*	
Calibrate ⁵	Sets user-writable registers to default	08	3Ah	SP +3	NA	NA	NA				0	0	*	*	*	*	*	

1. This is a software-only reset.
2. This operation should only be invoked by calling a function in the FlashBlock library. **Device specifications are no longer guaranteed if this function is directly called by the user's code.**
3. This function can only be invoked by the device programmer, not by user's code.
4. The address is hard coded by algorithm.
5. User-writeable registers include Main Oscillator Trim (IMO_TR), Internal Low Speed Oscillator Trim (ILO_TR), and Bandgap Trim (BDG_TR).

Notes:

NA: Not applicable

*: Indeterminate

Blk ID: Number of 64-byte block within FLASH memory space

Clock: CPU system clocking signal value

Pointer: Address of first byte of 64-byte block within SRAM memory space

TV: Table value

11.8.1 Additional Function for Table Read Supervisory Call

The Table Read supervisory operation will return the Version ID in the Accumulator. The value in the Accumulator is divided into a high and low nibble, indicating major and minor revisions, respectively. **Note:** The value in the X

register is modified during the Table Read Supervisory Call, and must be saved and restored if needed after the call completes.

- A[7:4]: Major silicon revisions.
- A[3:0]: Minor silicon revisions.

Table 99: Table Read for Supervisory Call Functions

Table ID	Function	TV(0)	TV(1)	TV(2)	TV(3)	TV(4)	TV(5)	TV(6)	TV(7)
00 ¹	Production Silicon ID	Silicon ID 1	Silicon ID 0	Reserved	Reserved	Reserved	Reserved	Reserved	Reserved
01	Provides trim value for Internal Main Oscillator and Internal Voltage Reference	Internal Voltage Reference trim value for 3.3V	Internal Main Oscillator trim value for 3.3V	Reserved	Reserved	Internal Voltage Reference trim value for 5.0V	Internal Main Oscillator trim value for 5.0V	Reserved	Reserved

1. Determines silicon revision values in Accumulator and X registers.

11.9 Flash Program Memory Protection

The user has the option to define the access to the Flash memory. A flexible system allows the user to select one of four protection modes for each 64-byte block within the Flash, based on the particular application. The protection mechanism is implemented by a device programmer using the System Supervisor Call. When this command is executed, two bits within the data programmed into the Flash will select the protection mode. It is not intended that the protection byte will be modified by the user's code. The following table lists the available protection options:

Table 100: Flash Program Memory Protection

Mode Bits	Mode Name	External Read	External Write	Internal Write
00	Unprotected	Enabled	Enabled	Enabled
01	Factory Upgrade	Disabled	Enabled	Enabled
10	Field Upgrade	Disabled	Disabled	Enabled
11	Full Protection	Disabled	Disabled	Disabled

Note: Mode 10 is the default.

11.10 Programming Requirements and Step Descriptions

The pins in the following table are critical for the programmer:

Table 101: Programmer Requirements

Pin Name	Function	Programmer HW Pin Requirements
SDATA	Serial Data In/Out	Drive TTL Levels, Read TTL, High Z
SCLK	Serial Clock	Drive TTL level Clock Signal
V _{SS}	Power Supply Ground Connection	Low Resistance Ground Connection
V _{CC}	Power Supply Positive Voltage	0V, 3.0V, 5V, & 5.4V. 0.1V Accuracy. 20mA Current Capability

11.10.1 Data File Read

The user's data file should be read into the programmer. The checksum should be calculated by the programmer for each record and compared to the record checksum stored in the file for each record. If there is an error, a message should be sent to the user explaining that the file has a checksum error and the programming should not be allowed to continue.

11.10.2 Programmer Flow

The following sequence (with descriptions) is the main flow used to program the devices: (Note that failure at any step will result in termination of the flow and an error message to the device programmer's operator.)

11.10.2.1 Verify Silicon ID

The silicon ID is read and verified against the expected value. If it is not the expected value, then the device is failed and an error message is sent to the device programmer's operator.

This test will detect a bad connection to the programmer or an incorrect device selection on the programmer.

The silicon ID test is required to be first in the flow and cannot be bypassed. The sequence is as follows:

```
Set Vcc=0V
Set SDATA=HighZ
Set SCLK=VILP
Set Vcc=Vccp
Start the programmer's SCLK driver
"free running"
WAIT-AND-POLL
ID-SETUP
WAIT-AND-POLL
READ-ID-WORD
```

Notes: See "DC Specifications" table in section 13 for value of Vccp and VILP. See "AC Specifications" table in section 13 for value of frequency for the SCLK driver (F_{sclk}).

11.10.2.2 Erase

The Flash memory is erased. This is accomplished by the following sequence:

```
SET-CLK-FREQ(num_MHz_times_5)
```

```
Erase All
WAIT-AND-POLL
```

11.10.2.3 Program

The Flash is programmed with the contents of the user's programming file. This is accomplished by the following sequence:

```
For num_block = 0 to max_data_block
For address =0 to 63
WRITE-BYTE(address,data) :
End for address loop
SET-CLK-FREQ(num_MHz_times_5)
SET-BLOCK-NUM(num_block)
PROGRAM-BLOCK
WAIT-AND-POLL
End for num_block loop
```

11.10.2.4 Verify (at Low Vcc and High Vcc)

The device data is read out to compare to the data in the user's programming file. This is accomplished by the following sequence:

```
For num_block = 0 to max_data_block
SET-BLOCK-NUM (num_block)
VERIFY-SETUP
Wait & POLL the SDATA for a high to
low transition
For address =0 to max_byte_per_block
READ-BYTE(address,data)
End for address loop
End for num_block loop
```

Note: This should be done 2 times; once at Vcc=Vcc_l and once at Vcc=Vcch_v.

11.10.2.5 Set Security

The security operation protects certain blocks from being read or changed. This is done at the end of the flow so that the security does not interfere with the verify step. Security is set with the following sequence:

```
For address =0 to 63
WRITE-SECURITY-BYTE(address,data) :
End for address loop
SET-CLK-FREQ(num_MHz_times_5)
SECURE
WAIT-AND-POLL
```

Note: This sequence is done at Vcc=Vcc_p.

11.10.2.6 Device Checksum (at Low Vcc and High Vcc)

The device checksum is retrieved from the device and compared to the “Device Checksum” from the user’s file (Note that this is NOT the same thing as the “Record Checksum.”) The checksum is retrieved from the device with the following sequence:

```
CHECKSUM-SETUP(max_data_block)
WAIT-AND-POLL
READ-CHECKSUM(data)
```

Note: This should be done 2 times; once at $V_{cc}=V_{cchv}$ and once at $V_{cc}=V_{cclv}$.

11.10.2.7 Power Down

The last step is to power down the device. This is accomplished by the following sequence:

```
Set SDATA=HighZ (float pin P1[0])
Set SCLK=0V (Vin on pin P1[1]=Vilp)
Set Vcc = 0V
```

11.11 Programming Wave Forms

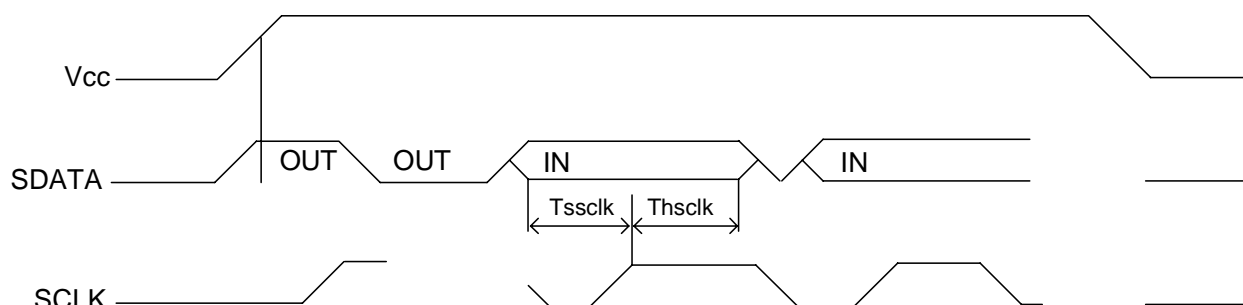

Figure 34: Programming Wave Forms

Notes:

- 1 Vcc is only turned off (0V) at the very beginning and the very end of the flow - not within the programming flow.
- 2 When the programmer puts the driver on SDATA in a High Z (floating) state, the SDATA pin will float to a low due to an internal device pull down circuit.
- 3 SCLK is set to VILP during the power up and power down; at other times the SCLK is “free running.” The frequency of the hardware’s SCLK signal must be known by the software because the value (entered in the number of MegaHertz multiplied by the number 5) must be passed into the device with the SET-CLK-FREQ() mnemonic.

11.12 Programming File Format

The programming file is created by PSoC Designer, the Cypress MicroSystems development tool. This tool generates the programming file in an Intel Hex format.

The programmer should assume the data is 30h/HALT if it is not specified in the user’s data file.

12.0 Development Tools

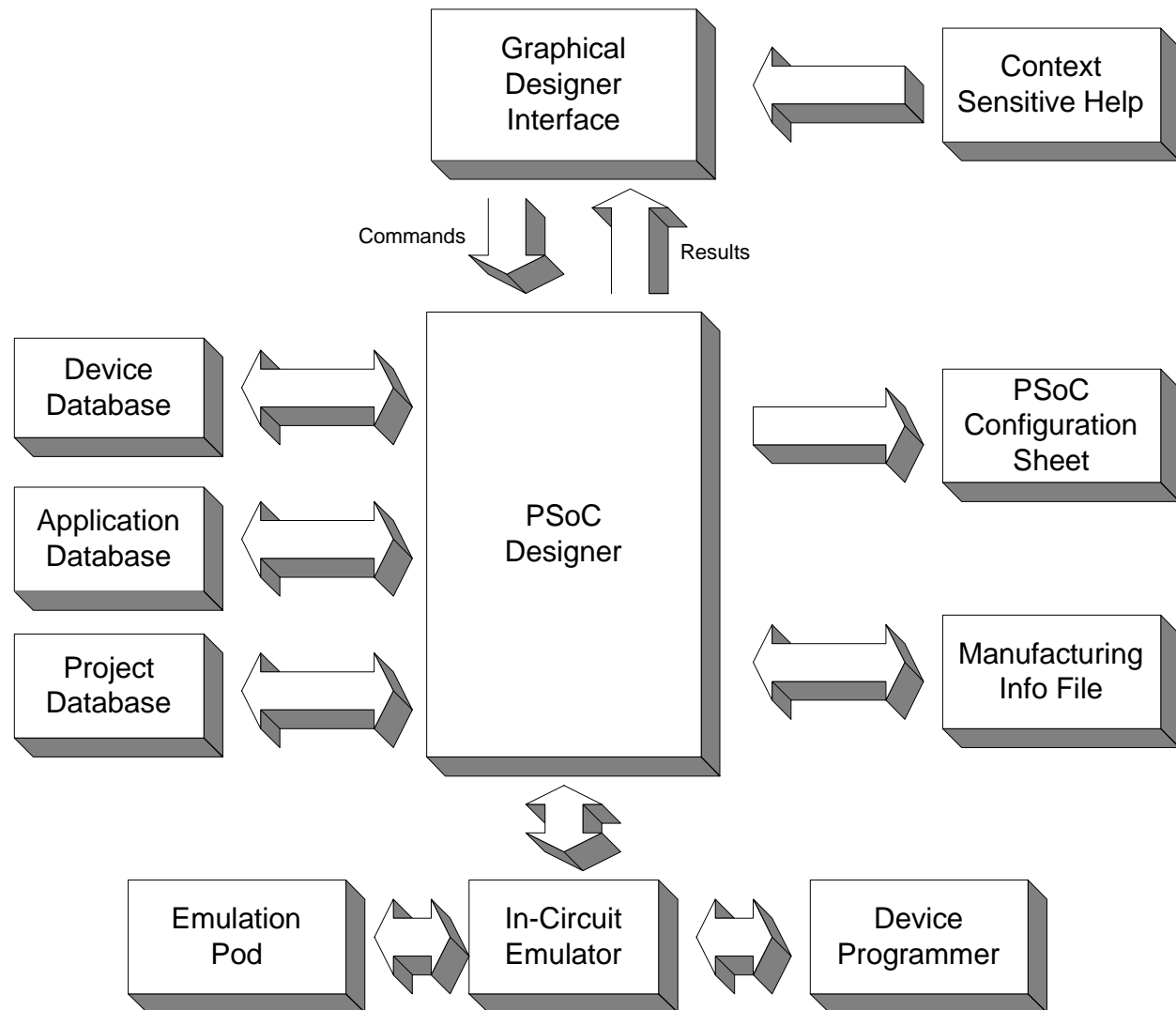

Figure 35: PSoC Designer Functional Flow

12.1 Overview

The Cypress MicroSystems PSoC Designer is a Microsoft® Windows-based, integrated development environment for the Programmable System-on-Chip (PSoC) devices. The PSoC Designer runs on Windows 98, Windows NT 4.0, Windows 2000, Windows Millennium (Me), or Windows XP.

PSoC Designer helps the customer to select an operating configuration for the microcontroller, write application code that uses the microcontroller, and debug the application. This system provides design database management by project, an integrated debugger with In-Circuit

Emulator, in-system programming support, and the CYASM macro assembler for the CPUs.

PSoC Designer also supports a high-level C language compiler developed specifically for the devices in the family.

12.2 Integrated Development Environment Subsystems

12.2.1 Online Help System

The online help system displays online, context-sensitive help for the user. Designed for procedural and quick reference, each functional subsystem has its own context-sensitive help. This system also provides tutorials and links to FAQs and an Online Support Forum to aid the designer in getting started.

12.2.2 Device Editor

PSoC Designer has several main functions. The Device Editor subsystem lets the user select different onboard analog and digital component configurations for the PSoC blocks. PSoC Designer sets up power-on initialization tables for selected PSoC block configurations and creates source code for an application framework. The framework contains software to operate the selected components and, if the project uses more than one operating configuration, contains routines to switch between different sets of PSoC block configurations at runtime. PSoC Designer can print out a configuration sheet for given project configuration for use during application programming in conjunction with the Device Data Sheet. Once the framework is generated, the user can add application-specific code to flesh out the framework. It's also possible to change the selected components and regenerate the framework.

12.2.3 Assembler

The included CYASM macro assembler supports the M8C microcontroller instruction set and generates a load file ready for device programming or system debugging using the ICE hardware.

12.2.4 C Language Software Development

A C language compiler supports Cypress MicroSystems' PSoC family devices. Even if you have never worked in the C language before, the product quickly allows you to create complete C programs for the PSoC family devices.

The embedded, optimizing C compiler provides all the features of C tailored to the PSoC architecture. It includes a built-in macro assembler allowing assembly

code to be merged seamlessly with C code. The link libraries automatically use absolute addressing or can be compiled in relative mode, and linked with other software modules to get absolute addressing.

The compiler comes complete with embedded libraries providing port and bus operations, standard keypad and display support, and extended math functionality.

12.2.5 Debugger

The PSoC Designer Debugger subsystem provides hardware in-circuit emulation, allowing the designer to test the program in a physical system while providing an internal view of the PSoC device. Debugger commands allow the designer to read and write program and data memory, read and write I/O registers, read and write CPU registers, set and clear breakpoints, and provide program run, halt, and step control. The debugger also allows the designer to create a trace buffer of registers and memory locations of interest.

12.3 Hardware Tools

12.3.1 In-Circuit Emulator

A low cost, high functionality ICE is available for development support. This hardware has the capability to program single devices.

13.0 DC and AC Characteristics

Specifications are valid for $-40\text{ }^{\circ}\text{C} \leq T_A \leq 85\text{ }^{\circ}\text{C}$ and $T_J \leq 100\text{ }^{\circ}\text{C}$ as specified, except where noted. Specifications for devices running at 24 MHz are valid at $-40\text{ }^{\circ}\text{C} \leq T_A \leq 70\text{ }^{\circ}\text{C}$ and $T_J \leq 82\text{ }^{\circ}\text{C}$.

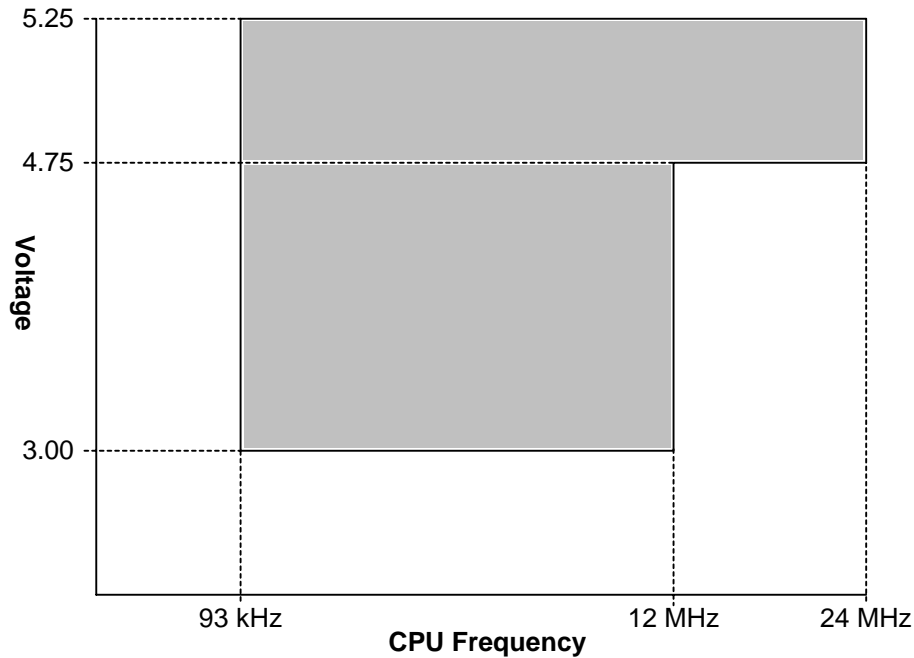

Figure 36: CY8C25xxx/CY8C26xxx Voltage Frequency Graph

13.1 Absolute Maximum Ratings

Table 102: Absolute Maximum Ratings

Symbol	Absolute Maximum Ratings	Minimum	Typical	Maximum	Unit
	Storage Temperature	-65	-	+100 ¹	$^{\circ}\text{C}$
	Ambient Temperature with Power Applied	-40	-	+85	$^{\circ}\text{C}$
	Supply Voltage on V_{CC} Relative to V_{SS}	-0.5	-	+6.0	V
	DC Input Voltage	-0.5	-	$V_{CC}+0.5$	V
	DC Voltage Applied to Tri-state	$V_{SS}-0.5$	-	$V_{CC}+0.5$	V
	Maximum Current into any Port Pin	-25	-	+50	mA
	Maximum Current into any Port Pin Configured as Analog Driver	-50	-	+50	mA
	Junction Temperature up to 12 MHz	-	-	100 ²	$^{\circ}\text{C}$
	Junction Temperature at 24 MHz	-	-	82	$^{\circ}\text{C}$
	Static Discharge Voltage	2000	-	-	V
	Latch-up Current	200	-	-	mA

1. Higher storage temperatures will reduce data retention time.

- The temperature rise from junction to ambient is package specific. (See [Table 122 on page 149](#) for thermal impedances of available packages.) User must limit power consumption to comply with this requirement.

Table 103: Temperature Specifications

Symbol	Temperature Specifications	Minimum	Typical	Maximum	Unit
T_A	Ambient Temperature	-40	24	+85	°C
T_J	Junction Temperature	-40		100	°C

13.2 DC Characteristics

Table 104: DC Operating Specifications

Symbol	DC Operating Specifications	Minimum	Typical	Maximum	Unit
V_{CC}	Supply Voltage	3.00	-	5.25	V
I_{CC}	Supply Current	-	5	8^1	mA
I_{sb}	Sleep (Mode) Current	-	-	5^2	μ A
I_{sbxtl}	Sleep (Mode) Current with Crystal Oscillator	-	3	5^3	μ A
V_{ref}	Reference Voltage (Bandgap)	1.275	1.3	1.325^4	V
V_{il}	Input Low Voltage	-	-	0.8	V
V_{ih}	Input High Voltage	2.2	-	-	V
V_h	Hysteresis Voltage	-	60	-	mV
V_{ol}	Output Low Voltage	-	-	$V_{SS}+0.75^5$	V
V_{oh}	Output High Voltage	$V_{CC}-1.0^6$	-	-	V
R_{pu}	Pull Up Resistor Value	4000	5600	8000	Ω
R_{pd}	Pull Down Resistor Value	4000	5600	8000	Ω
I_{il}	Input Leakage (Absolute Value)	-	0.1	5	μ A
C_{in}	Capacitive Load on Pins as Input	0.5	1.7	10^7	pF
C_{out}	Capacitive Load on Pins as Output	0.5	1.7	10^7	pF
V_{LVD}	LVD and SMP Tolerance ⁸	$0.95 \times \text{Ideal}^8$	Ideal	$1.05 \times \text{Ideal}^8$	V

1. Conditions are 5.0V, 25 °C, 3 MHz.
2. Without Crystal Oscillator, $V_{CC} = 3.3$ V, $T_A \leq 85$ °C.
3. Conditions are $3.0V \leq V_{CC} \leq 3.6V$, -40 °C $\leq T_A \leq 85$ °C. Correct operation assumes a properly loaded, 1 uW maximum drive level, 32.768 kHz crystal.
4. Trimmed for appropriate V_{CC} .
5. $I_{sink} = 25$ mA, $V_{CC} = 4.5$ V (maximum of 8 IO sinking, 4 on each side of the IC).
6. $I_{source} = 10$ mA, $V_{CC} = 4.5$ V (maximum of 8 IO sourcing, 4 on each side of the IC).
7. Package dependent.
8. Ideal values are +/- 5% absolute tolerance and +/- 1% tolerance relative to each other (for adjacent levels).

13.2.1 DC Operational Amplifier Specifications

13.2.1.1 5V Specifications

The following table lists guaranteed maximum and minimum specifications for the voltage and temperature ranges, 5V +/- 5% and $-40^{\circ}\text{C} \leq T_A \leq 85^{\circ}\text{C}$. The Operational Amplifier is a component of both the Analog Continuous Time PSoC blocks and the Analog Switch Cap

PSoC blocks. The guaranteed specifications are measured in the Analog Continuous Time PSoC block. Typical parameters apply to 5V at 25°C and are for design guidance only. For 3.3V operation, see [Table 106 on page 131](#).

Table 105: 5V DC Operational Amplifier Specifications

Symbol	5V DC Operational Amplifier Specifications	Minimum	Typical	Maximum	Unit
	Input Offset Voltage (Absolute Value)	-	7	30	mV
	Average Input Offset Voltage Drift	-	+24	-	$\mu\text{V}/^{\circ}\text{C}$
	Input Leakage Current ¹	-	3	1000	nA
	Input Capacitance ²	.30	.34	.40	pF
	Common Mode Voltage Range ³	.5	-	$V_{\text{CC}} - 1.0$	VDC
	Common Mode Rejection Ratio	80	-	-	dB
	Open Loop Gain	80	-	-	dB
	High Output Voltage Swing (Worst Case Internal Load)				
	Bias = Low	$V_{\text{CC}} - .4$	-	-	V
	Bias = Medium	$V_{\text{CC}} - .4$	-	-	V
	Bias = High	$V_{\text{CC}} - .4$	-	-	V
	Low Output Voltage Swing (Worst Case Internal Load)				
	Bias = Low	-	-	0.1	V
	Bias = Medium	-	-	0.1	V
	Bias = High	-	-	0.1	V
	Supply Current (Including Associated AGND Buffer)				
	Bias = Low	-	125	300	μA
	Bias = Medium	-	280	600	μA
	Bias = High	-	760	1500	μA
	Supply Voltage Rejection Ratio	60	-	-	dB

1. The leakage current includes the Analog Continuous Time PSoC block mux and the analog input mux. The leakage related to the General Purpose I/O pins is not included here.
2. The Input Capacitance includes the Analog Continuous Time PSoC block mux and the analog input mux. The capacitance of the General Purpose I/O pins is not included here.
3. The common-mode input voltage range is measured through an analog output buffer. The specification includes the limitations imposed by the characteristics of the analog output buffer.

13.2.1.2 3.3V Specifications

The following table lists guaranteed maximum and minimum specifications for the voltage and temperature ranges, 3.3V +/- 10% and $-40^{\circ}\text{C} \leq T_A \leq 85^{\circ}\text{C}$. The Operational Amplifier is a component of both the Analog Continuous Time PSoC blocks and the Analog Switch

Cap PSoC blocks. The guaranteed specifications are measured in the Analog Continuous Time PSoC block. Typical parameters apply to 5V at 25°C and are for design guidance only. For 5V operation, see [Table 105 on page 130](#).

Table 106: 3.3V DC Operational Amplifier Specifications

Symbol	3.3V DC Operational Amplifier Specifications	Minimum	Typical	Maximum	Unit
	Input Offset Voltage (Absolute Value)	-	7	30	mV
	Average Input Offset Voltage Drift	-	+24	-	$\mu\text{V}/^{\circ}\text{C}$
	Input Leakage Current ¹	-	2	700	nA
	Input Capacitance ²	.32	.36	.42	pF
	Common Mode Voltage Range ³	.5	-	$V_{\text{CC}} - 1.0$	VDC
	Common Mode Rejection Ratio	80	-	-	dB
	Open Loop Gain	80	-	-	dB
	High Output Voltage Swing (Worst Case Internal Load)				
	Bias = Low	$V_{\text{CC}} - .4$	-	-	V
	Bias = Medium	$V_{\text{CC}} - .4$	-	-	V
	Bias = High	$V_{\text{CC}} - .4$	-	-	V
	Low Output Voltage Swing (Worst Case Internal Load)				
	Bias = Low	-	-	0.1	V
	Bias = Medium	-	-	0.1	V
	Bias = High	-	-	0.1	V
	Supply Current (Including Associated AGND Buffer)				
	Bias = Low	-	80	200	μA
	Bias = Medium	-	112	300	μA
	Bias = High	-	320	800	μA
	Supply Voltage Rejection Ratio	60	-	-	dB

1. The leakage current includes the Analog Continuous Time PSoC block mux and the analog input mux. The leakage related to the General Purpose I/O pins is not included here.
2. The Input Capacitance includes the Analog Continuous Time PSoC block mux and the analog input mux. The capacitance of the General Purpose I/O pins is not included here.
3. The common-mode input voltage range is measured through an analog output buffer. The specification includes the limitations imposed by the characteristics of the analog output buffer

13.2.2 Analog Input Pin with Multiplexer Specifications

Table 107: DC Analog Input Pin with Multiplexer Specifications

Symbol	DC Analog Input Pin with Multiplexer Specifications	Minimum	Typical	Maximum	Unit
	Input Leakage (Absolute Value)	-	0.1	5	μA
	Input Capacitance	0.5	1.7	8	pF
	Bandwidth	-	10	-	MHz
	Input Voltage Range	0	-	V_{CC}	V

13.2.3 Analog Input Pin to Switch Cap Block Specifications

Table 108: DC Analog Input Pin to SC Block Specifications

Symbol	DC Analog Input Pin to SC Block Specifications	Minimum	Typical	Maximum	Unit
	Effective input resistance = $1/(f \times c)$	-	5^1	-	$\text{M}\Omega$
	Input Capacitance	0.5	-	10	pF
	Bandwidth	-	-	100^2	kHz
	Input Voltage Range	0	-	V_{CC}	V

1. Assumes 2 pF cap selected and 100 kHz sample frequency.
2. This is a sampled input. Recommendation is $F_s/F_{in} > 10$ and for $F_s = 1 \text{ MHz}$ $F_{in} < 100 \text{ kHz}$.

13.2.4 DC Analog Output Buffer Specifications

The following table lists guaranteed maximum and minimum specifications for the voltage and temperature ranges, $5\text{V} \pm 5\%$ and $-40^\circ\text{C} \leq T_A \leq 85^\circ\text{C}$. Typical parameters apply to 5V at 25°C and are for design guidance only. For 3.3V operation, see [Table 110 on page 133](#).

Table 109: 5V DC Analog Output Buffer Specifications

Symbol	5V DC Analog Output Buffer Specifications	Minimum	Typical	Maximum	Unit
	Input Offset Voltage (Absolute Value)	-	3	12	mV
	Average Input Offset Voltage Drift	-	+6	-	$\mu\text{V}/^\circ\text{C}$
	Common-Mode Input Voltage Range	.5	-	$V_{CC} - 1.0$	V
	Output Resistance Bias = Low Bias = High	- -	1 1	- -	Ω Ω
	High Output Voltage Swing (Load = 32 ohms to $V_{CC}/2$) Bias = Low Bias = High	$.5 \times V_{CC} + 1.3$ $.5 \times V_{CC} + 1.3$	- -	- -	V V
	Low Output Voltage Swing (Load = 32 ohms to $V_{CC}/2$) Bias = Low Bias = High	- -	- -	$.5 \times V_{CC} - 1.3$ $.5 \times V_{CC} - 1.3$	V V
	Supply Current Including Bias Cell (No Load) Bias = Low Bias = High	- -	1.1 2.6	5.1 8.8	mA mA
	Supply Voltage Rejection Ratio	80	-	-	dB

The following table lists guaranteed maximum and minimum specifications for the voltage and temperature ranges, 3.3V +/- 10% and $-40^{\circ}\text{C} \leq T_A \leq 85^{\circ}\text{C}$. Typical parameters apply to 5V at 25°C and are for design guidance only. For 5V operation, see [Table 109 on page 132](#).

Table 110: 3.3V DC Analog Output Buffer Specifications

Symbol	3.3V DC Analog Output Buffer Specifications	Minimum	Typical	Maximum	Unit
	Input Offset Voltage (Absolute Value)	-	3	12	mV
	Average Input Offset Voltage Drift	-	+6	-	$\mu\text{V}/^{\circ}\text{C}$
	Common-Mode Input Voltage Range	.5	-	$V_{\text{CC}} - 1.0$	V
	Output Resistance				
	Bias = Low	-	1	-	Ω
	Bias = High	-	1	-	Ω
	High Output Voltage Swing (Load = 32 ohms to $V_{\text{CC}}/2$)				
	Bias = Low	$.5 \times V_{\text{CC}} + 1.3$	-	-	V
	Bias = High	$.5 \times V_{\text{CC}} + 1.3$	-	-	V
	Low Output Voltage Swing (Load = 32 ohms to $V_{\text{CC}}/2$)				
	Bias = Low	-	-	$.5 \times V_{\text{CC}} - 1.3$	V
	Bias = High	-	-	$.5 \times V_{\text{CC}} - 1.3$	V
	Supply Current Including Bias Cell (No Load)				
	Bias = Low	-	0.8	2.0	mA
	Bias = High	-	2.0	4.3	mA
	Supply Voltage Rejection Ratio	80	-	-	dB

13.2.5 Switch Mode Pump Specifications

Table 111: DC Switch Mode Pump Specifications

Symbol	DC Switch Mode Pump Specifications	Minimum	Typical	Maximum	Unit
	Output Voltage ¹	3.07	-	5.15	V
	Available Output Current $V_i = 1.5\text{ V}, V_o = 3.25\text{ V}$ $V_i = 1.5\text{ V}, V_o = 5.0\text{ V}$	8 ² 5	- -	- -	mA mA
	Short Circuit Current ($V_i = 3.3\text{ V}$)	-	12	-	mA
	Input Voltage Range (During sustained operation)	1.0	-	3.3	V
	Minimum Input Voltage to Start Pump	1.1	1.2	-	
	Output Voltage Tolerance (Over V_i Range)	-	5	-	% V_o
	Line Regulation (Over V_i Range)	-	5	-	% V_o
	Load Regulation	-	5	-	% V_o
	Output Voltage Ripple (Depends on capacitor and load)	-	25 ³	-	mV _{pp}
	Transient Response 50% Load Change to 5% error envelope V_o Over/Undershoot for 50% Load Change	- -	1 1	- -	μs % V_o
	Efficiency	35 ⁴	50	-	%
	Switching Frequency	-	1.3	-	MHz
	Switching Duty Cycle	-	50	-	%

1. Average, neglecting ripple.
2. For implementation, which includes 2 μH inductor, 1 μF capacitor, and Schottkey diode. Performance is significantly a function of external components. Specifications guaranteed for inductors with series resistance less than 0.1 W, with a current rating of > 250 mA, a capacitor with less than 1 μA leakage at 5V, and Schottkey diode with less than 0.6V of drop at 50 mA.
3. Configuration of note 2. Load is 5 mA.
4. Configuration of note 2. Load is 5 mA. V_{out} is 3.25V.

13.2.6 DC Analog Reference Specifications

The following table lists guaranteed maximum and minimum specifications for the voltage and temperature ranges, 5V +/- 5% and -40°C <= TA <= 85°C. The guaranteed specifications are measured through the Analog Continuous Time PSoC blocks. The bias levels for AGND refer to the bias of the Analog Continuous Time PSoC block. The bias levels for RefHi and RefLo refer to

the Analog Reference Control Register. The limits stated for AGND include the offset error of the AGND buffer local to the Analog Continuous Time PSoC block. Typical parameters apply to 5V at 25C and are for design guidance only. (3.3V replaces 5V for the 3.3V DC Analog Reference Specifications.)

Table 112: 5V DC Analog Reference Specifications

Symbol	5V DC Analog Reference Specifications	Minimum	Typical	Maximum	Unit
	AGND = $V_{CC}/2$ ¹ CT Block Bias = High	$V_{CC}/2 - 0.010$	$V_{CC}/2 - 0.004$	$V_{CC}/2 + 0.003$	V
	AGND = $2 * \text{BandGap}$ ¹ CT Block Bias = High	$2 * \text{BG} - 0.043$	$2 * \text{BG} - 0.010$	$2 * \text{BG} + 0.024$	V
	AGND = P2[4] (P2[4] = $V_{CC}/2$) ¹ CT Block Bias = High	P24 - 0.013	P24 0.001	P24 + 0.014	V
	AGND Column to Column Variation (AGND= $V_{CC}/2$) ¹ CT Block Bias = High	-0.034	0.000	0.034	mV
	REFHI = $V_{CC}/2 + \text{BandGap}$ Ref Control Bias = High	$V_{CC}/2 + \text{BG} - 0.140$	$V_{CC}/2 + \text{BG} - 0.018$	$V_{CC}/2 + \text{BG} + 0.103$	V
	REFHI = $3 * \text{BandGap}$ Ref Control Bias = High	$3 * \text{BG} - 0.112$	$3 * \text{BG} - 0.018$	$3 * \text{BG} + 0.076$	V
	REFHI = $2 * \text{BandGap} + \text{P2}[6]$ (P2[6] = 1.3V) Ref Control Bias = High	$2 * \text{BG} + \text{P2}[6] - 0.113$	$2 * \text{BG} + \text{P2}[6] - 0.018$	$2 * \text{BG} + \text{P2}[6] + 0.077$	V
	REFHI = P2[4] + BandGap (P2[4] = $V_{CC}/2$) Ref Control Bias = High	P2[4]+BG - 0.130	P2[4]+BG - 0.016	P2[4]+BG + 0.098	V
	REFHI = P2[4] + P2[6] (P2[4] = $V_{CC}/2$, P2[6] = 1.3V) Ref Control Bias = High	P2[4]+P2[6] - 0.133	P2[4]+P2[6] - 0.016	P2[4]+P2[6] + 0.100	V
	REFLO = $V_{CC}/2 - \text{BandGap}$ Ref Control Bias = High	$V_{CC}/2 - \text{BG} - 0.051$	$V_{CC}/2 - \text{BG} + 0.024$	$V_{CC}/2 - \text{BG} + 0.098$	V
	REFLO = BandGap Ref Control Bias = High	BG - 0.082	BG + 0.023	BG + 0.129	V
	REFLO = $2 * \text{BandGap} - \text{P2}[6]$ (P2[6] = 1.3V) Ref Control Bias = High	$2 * \text{BG} - \text{P2}[6] - 0.084$	$2 * \text{BG} - \text{P2}[6] + 0.025$	$2 * \text{BG} - \text{P2}[6] + 0.134$	V
	REFLO = P2[4] - BandGap (P2[4] = $V_{CC}/2$) Ref Control Bias = High	P2[4]-BG - 0.056	P2[4]-BG + 0.026	P2[4]-BG + 0.107	V
	REFLO = P2[4]-P2[6] (P2[4] = $V_{CC}/2$, P2[6] = 1.3V) Ref Control Bias = High	P2[4]-P2[6] - 0.057	P24-P26 + 0.026	P2[4]-P2[6] + 0.110	V

Table 113: 3.3V DC Analog Reference Specifications

Symbol	3.3V DC Analog Reference Specifications	Minimum	Typical	Maximum	Unit
	AGND = $V_{cc}/2$ ¹ CT Block Bias = High	$V_{cc}/2 - 0.007$	$V_{cc}/2 - 0.003$	$V_{cc}/2 + 0.002$	V
	AGND = $2 * \text{BandGap}$ ¹ CT Block Bias = High	Not Allowed			
	AGND = P2[4] (P2[4] = $V_{cc}/2$) CT Block Bias = High	$P24 - 0.008$	$P24 + 0.001$	$P24 + 0.009$	V
	AGND Column to Column Variation (AGND= $V_{cc}/2$) ¹ CT Block Bias = High	-0.034	0.000	0.034	mV
	REFHI = $V_{cc}/2 + \text{BandGap}$ Ref Control Bias = High	Not Allowed			
	REFHI = $3 * \text{BandGap}$ Ref Control Bias = High	Not Allowed			
	REFHI = $2 * \text{BandGap} + P2[6]$ (P2[6] = 0.5V) Ref Control Bias = High	Not Allowed			
	REFHI = P2[4] + BandGap (P2[4] = $V_{cc}/2$) Ref Control Bias = High	Not Allowed			
	REFHI = P2[4] + P2[6] (P2[4] = $V_{cc}/2$, P2[6] = 0.5V) Ref Control Bias = High	$P2[4]+P2[6] - 0.075$	$P2[4]+P2[6] - 0.009$	$P2[4]+P2[6]+ 0.057$	V
	REFLO = $V_{cc}/2 - \text{BandGap}$ Ref Control Bias = High	Not Allowed			
	REFLO = BandGap Ref Control Bias = High	Not Allowed			
	REFLO = $2 * \text{BandGap} - P2[6]$ (P2[6] = 0.5V) Ref Control Bias = High	Not Allowed			
	REFLO = P2[4] - BandGap (P2[4] = $V_{cc}/2$) Ref Control Bias = High	Not Allowed			
	REFLO = P2[4]-P2[6] (P2[4] = $V_{cc}/2$, P2[6] = 0.5V) Ref Control Bias = High	$P2[4]-P2[6] - 0.048$	$P24-P26 + 0.022$	$P2[4]-P2[6] + 0.092$	V

1. AGND tolerance includes the offsets of the local buffer in the PSoC block. Bandgap voltage is $1.3V \pm 2\%$

13.2.7 DC Analog PSoC Block Specifications

The following table lists guaranteed maximum and minimum specifications include both voltage ranges, 5V +/- 5% and 3.3V +/- 10% and the temperature range -40°C

$\leq T_A \leq 85^\circ\text{C}$. Typical parameters apply to 3.3V and 5V at 25°C and are for design guidance only.

Table 114: DC Analog PSoC Block Specifications

Symbol	DC Analog PSoC Block Specifications	Minimum	Typical	Maximum	Unit
	Resistor Unit Value (Continuous Time)	-	45	-	k Ω
	Capacitor Unit Value (Switch Cap)	-	70	-	fF

13.2.8 DC Programming Specifications

Table 115: DC Programming Specifications

Symbol	DC Programming Specifications	Minimum	Typical	Maximum	Unit
I_{ccp}	Supply Current During Programming or Verify	-	5	20	mA
V_{ilp}	Input Low Voltage During Programming or Verify	-	-	0.8	V
V_{ihp}	Input High Voltage During Programming or Verify	2.2	-	-	V
I_{ilp}	Input Current when Applying V_{ilp} to P1[0] or P1[1] During Programming or Verify	-	-	0.2	mA
I_{ihp}	Input Current when Applying V_{ihp} to P1[0] or P1[1] During Programming or Verify	-	-	1.5 ¹	mA
V_{olv}	Output Low Voltage During Programming or Verify	-	-	$V_{ss} + 0.75$	V
V_{ohv}	Output High Voltage During Programming or Verify	$V_{cc} - 1.0$	-	V_{cc}	V
Flash _{enpb}	Flash Endurance (Per Block)	50,000	-	-	E/W Cycles per Block
Flash _{ent}	Flash Endurance (Total) ²	1,800,000	-	-	E/W Cycles
Flash _{dr}	Flash Data Retention (After Cycling)	10	-	-	Years

1. Driving internal pull-down resistor.
2. A maximum of 36 x 50,000 block endurance cycles is allowed. This may be balanced between operations on 36x1 blocks of 50,000 maximum cycles each, 36x2 blocks of 25,000 maximum cycles each, or 36x4 blocks of 12,500 maximum cycles each (and so forth to limit the total number of cycles to 36x50,000 and that no single block ever sees more than 50,000 cycles).

The CY8C25xxx/26xxx family of PSoC devices uses an adaptive algorithm to enhance endurance over the industrial temperature range (-40°C to +85°C ambient). Any temperature range within a 50°C span between 0°C and 85°C is considered constant with respect to endurance enhancements. For instance, if room temperature (25°C) is the nominal operating temperature, then the range from 0°C to 50°C can be approximated by the constant value 25 and a temperature sensor is not needed.

For the full industrial range, the user must employ a temperature sensor User Module (FlashTemp) and feed the result to the temperature argument before writing. Refer to the Flash APIs Application Note AN2015 at <http://www.cypressmicro.com> under Support or Active Design Support for more information.

13.3 AC Characteristics

Table 116: AC Operating Specifications

Symbol	AC Operating Specifications	Minimum	Typical	Maximum	Unit
F _{CPU1}	CPU Frequency (5 V Nominal) ^{1,2,3}	91.35	2,400	2,460	kHz
F _{CPU2}	CPU Frequency (3.3V Nominal) ^{4,3}	91.35	1,200	1,230	kHz
F _{48M}	Digital PSoC Block Frequency		48	49.2 ^{1,5}	MHz
F _{24M}	Digital PSoC Block Frequency		24	24.6 ^{2,4}	MHz
F _{GPIO}	GPIO Operating Frequency		12		MHz
F _{IMO}	Internal Main Oscillator Frequency (0°C to +85°C)	23.4	24	24.6	MHz
F _{IMOC}	Internal Main Oscillator Frequency Cold (-40°C to 0°C)	22.44	24	24.6	MHz
F _{32K1}	Internal Low Speed Oscillator Frequency (Non Sleep)	15 ⁶	32	50	kHz
F _{32K2}	Internal Low Speed Oscillator Frequency (Sleep or Halt)	15 ⁷	32	64	kHz
F _{32K3}	External Crystal Oscillator	-	32.768 ⁸	-	kHz
F _{pll}	PLL Frequency	-	23.986 ⁹	-	MHz
T _f	Output Fall Time	2 ¹⁰	-	12	ns
T _r	Output Rise Time	3 ¹⁰	-	18	ns
T _{pllslew}	PLL Lock Time	0.5	-	10	ms
SV _{dd}	V _{dd} Rise Rate at Power Up	80 ¹¹	-	-	mV/ms
T _{os}	External Crystal Oscillator Startup to 1%	-	100	500 ¹²	ms
T _{osacc}	External Crystal Oscillator Startup to 100 ppm	-	150	600 ¹³	ms
T _{xrst}	External Reset Pulse Width	10	-	-	μs

1. 4.75V < V_{cc} < 5.25V.
2. Accuracy derived from Internal Main Oscillator with appropriate trim for V_{cc} range.
3. 0°C to +85°C.
4. 3.0V < V_{cc} < 3.6V.
5. See Application Note AN2012 "Adjusting PSoC Microcontroller Trims for Dual Voltage-Range Operation" for information on maximum frequency for User Modules.
6. Limits are valid only when *not* in sleep mode.
7. Limits are valid only when in sleep mode.
8. Accuracy is capacitor and crystal dependent.
9. Is a multiple (x732) of crystal frequency.
10. Load capacitance = 50 pF.
11. To minimum allowable voltage for desired frequency.
12. The crystal oscillator frequency is guaranteed to be within 1% of its final value by the end of the 1s startup timer period. Timer period may be as short as 640 ms for the case where F_{32K1} is 50 kHz. Correct operation assumes a properly loaded 1uW maximum drive level 32.768 kHz crystal.
13. The crystal oscillator frequency is within 100 ppm of its final value by the end of the T_{osacc} period. Correct operation assumes a properly loaded 1 uW maximum drive level 32.768 kHz crystal. 3.0V ≤ V_{cc} ≤ 5.5V, -40 °C ≤ T_A ≤ 85 °C.

13.3.1 AC Operational Amplifier Specifications

The following table lists guaranteed maximum and minimum specifications for the voltage and temperature ranges, 5V +/- 5% and $-40^{\circ}\text{C} \leq T_A \leq 85^{\circ}\text{C}$. Typical parameters are provided for design guidance only. Typical parameters apply to 5V and 25°C. Settling times and slew rates are based on the Analog Switch Cap PSoC

block. The block is configured as an auto zeroed, gain of 0.5, output sampled amplifier. All 32-feedback caps are on, 16 input caps are used (divide by 2), and the output steps of 0.625V. Gain bandwidth is based on Analog Continuous Time PSoC blocks. For 3.3V operation, see [Table 118 on page 140](#).

Table 117: 5V AC Operational Amplifier Specifications

Symbol	5V AC Operational Amplifier Specifications	Minimum	Typical	Maximum	Unit
	Rising Settling Time to 0.1%				
	Bias = Low	-	-	2.7	μs
	Bias = Medium	-	-	1.4	μs
	Bias = High	-	-	0.6	μs
	Falling Settling Time to 0.1%				
	Bias = Low	-	-	1.7	μs
	Bias = Medium	-	-	0.9	μs
	Bias = High	-	-	0.5	μs
	Rising Slew Rate (20% to 80%)				
	Bias = Low	0.4	-	-	V/ μs
	Bias = Medium	0.7	-	-	V/ μs
	Bias = High	2.0	-	-	V/ μs
	Falling Slew Rate (80% to 20%)				
	Bias = Low	0.7	-	-	V/ μs
	Bias = Medium	1.7	-	-	V/ μs
	Bias = High	2.5	-	-	V/ μs
	Gain Bandwidth Product				
	Bias = Low	1.7	-	-	MHz
	Bias = Medium	4.6	-	-	MHz
	Bias = High	8.9	-	-	MHz

Table 118: 3.3V AC Operational Amplifier Specifications

Symbol	3.3V AC Operational Amplifier Specifications	Minimum	Typical	Maximum	Unit
	Rising Settling Time to 0.1%				
	Bias = Low	-	-	3.0	μs
	Bias = Medium	-	-	1.6	μs
	Bias = High	-	-	1.5	μs
	Falling Settling Time to 0.1%				
	Bias = Low	-	-	2.6	μs
	Bias = Medium	-	-	1.7	μs
	Bias = High	-	-	1.6	μs
	Rising Slew Rate (20% to 80%)				
	Bias = Low	0.2	-	-	V/ μs
	Bias = Medium	0.3	-	-	V/ μs
	Bias = High	0.3	-	-	V/ μs
	Falling Slew Rate (80% to 20%)				
	Bias = Low	0.3	-	-	V/ μs
	Bias = Medium	0.3	-	-	V/ μs
	Bias = High	0.3	-	-	V/ μs
	Gain Bandwidth Product				
	Bias = Low	1.5	-	-	MHz
	Bias = Medium	4.4	-	-	MHz
	Bias = High	8.7	-	-	MHz

13.3.2 AC Analog Output Buffer Specifications

The following table lists guaranteed maximum and minimum specifications for the voltage and temperature ranges, 5V +/- 5% and $-40^{\circ}\text{C} \leq T_A \leq 85^{\circ}\text{C}$. Typical parameters are provided for design guidance only. Typical parameters apply to 5V and 25°C. For 3.3V operation, see [Table 120 on page 142](#).

Table 119: 5V AC Analog Output Buffer Specifications

Symbol	5V AC Analog Output Buffer Specifications	Minimum	Typical	Maximum	Unit
	Rising Settling Time to 0.1%, 1V Step, 100pF Load Bias = Low	-	-	2.5	μs
	Bias = High	-	-	2.5	μs
	Falling Settling Time to 0.1%, 1V Step, 100pF Load Bias = Low	-	-	2.2	μs
	Bias = High	-	-	2.2	μs
	Rising Slew Rate (20% to 80%), 1V Step, 100pF Load Bias = Low	.9	-	-	V/ μs
	Bias = High	.9	-	-	V/ μs
	Falling Slew Rate (80% to 20%), 1V Step, 100pF Load Bias = Low	.9	-	-	V/ μs
	Bias = High	.9	-	-	V/ μs
	Small Signal Bandwidth, 20mV _{pp} , 3dB BW, 100pF Load Bias = Low	1.5	-	-	MHz
	Bias = High	1.5	-	-	MHz
	Large Signal Bandwidth, 1V _{pp} , 3dB BW, 100pF Load Bias = Low	600	-	-	kHz
	Bias = High	600	-	-	kHz

Table 120: 3.3V AC Analog Output Buffer Specifications

Symbol	3.3V AC Analog Output Buffer Specifications	Minimum	Typical	Maximum	Unit
	Rising Settling Time to 0.1%, 1V Step, 100pF Load Bias = Low	-	-	3.2	μs
	Bias = High	-	-	3.2	μs
	Falling Settling Time to 0.1%, 1V Step, 100pF Load Bias = Low	-	-	2.6	μs
	Bias = High	-	-	2.6	μs
	Rising Slew Rate (20% to 80%), 1V Step, 100pF Load Bias = Low	.5	-	-	V/ μs
	Bias = High	.5	-	-	V/ μs
	Falling Slew Rate (80% to 20%), 1V Step, 100pF Load Bias = Low	.5	-	-	V/ μs
	Bias = High	.5	-	-	V/ μs
	Small Signal Bandwidth, 20mV _{pp} , 3dB BW, 100pF Load Bias = Low	1.3	-	-	MHz
	Bias = High	1.3	-	-	MHz
	Large Signal Bandwidth, 1V _{pp} , 3dB BW, 100pF Load Bias = Low	360	-	-	kHz
	Bias = High	360	-	-	kHz

13.3.3 AC Programming Specifications

Table 121: AC Programming Specifications

Symbol	AC Programming Specifications	Minimum	Typical	Maximum	Unit
T _{rsclk}	Rise Time of SCLK	1	-	20	ns
T _{fsclk}	Fall Time of SCLK	1	-	20	ns
T _{ssclk}	Data Set up Time to Rising Edge of SCLK	25	-	-	ns
T _{hsclk}	Data Hold Time from Rising Edge of SCLK	25	-	-	ns
F _{sclk}	Frequency of SCLK	2	-	20	MHz
T _{eraseb}	Flash Erase Time (Block)	-	10	-	ms
T _{erasesf}	Flash Erase Time (Full)	-	40	-	ms
T _{write}	Flash Block Write Time	2	10	20	ms

14.0 Packaging Information

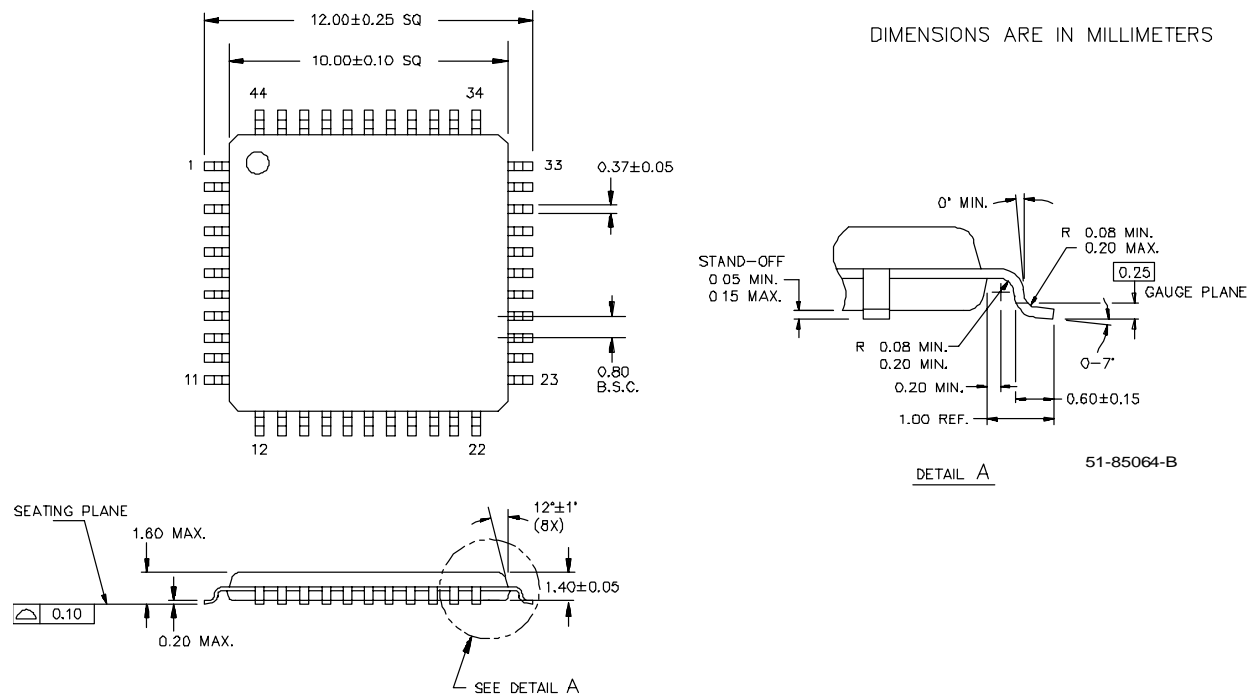

Figure 37: 44-Lead Thin Plastic Quad Flat Pack A44

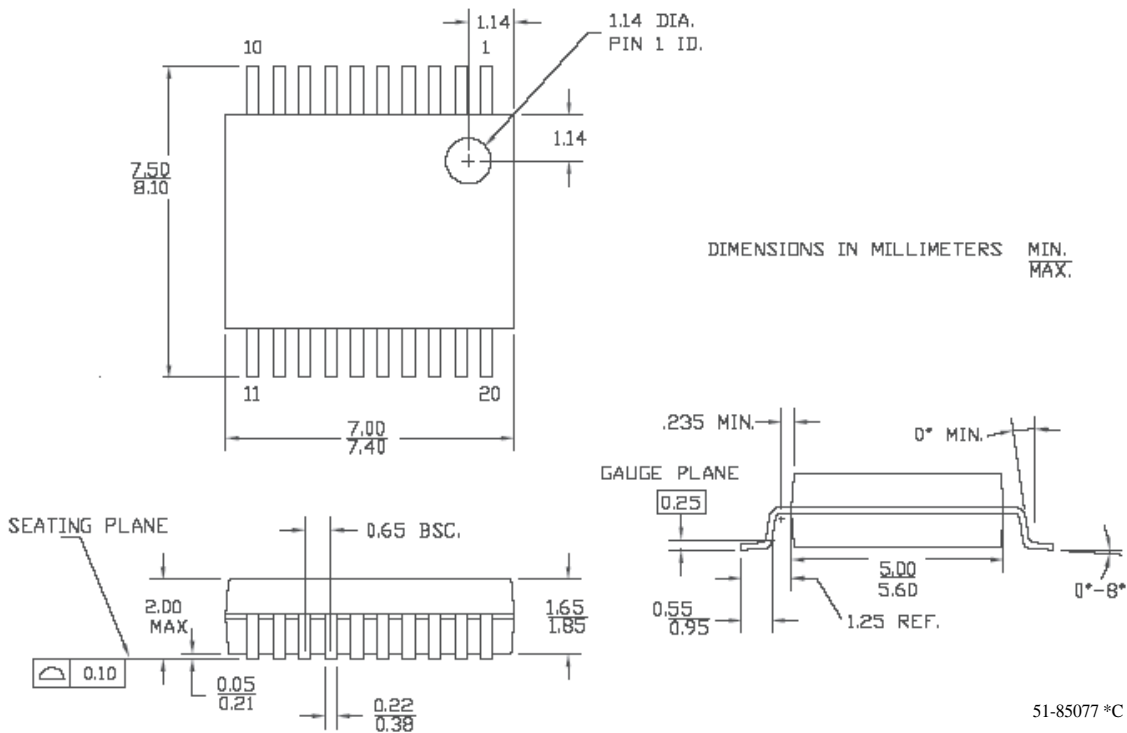
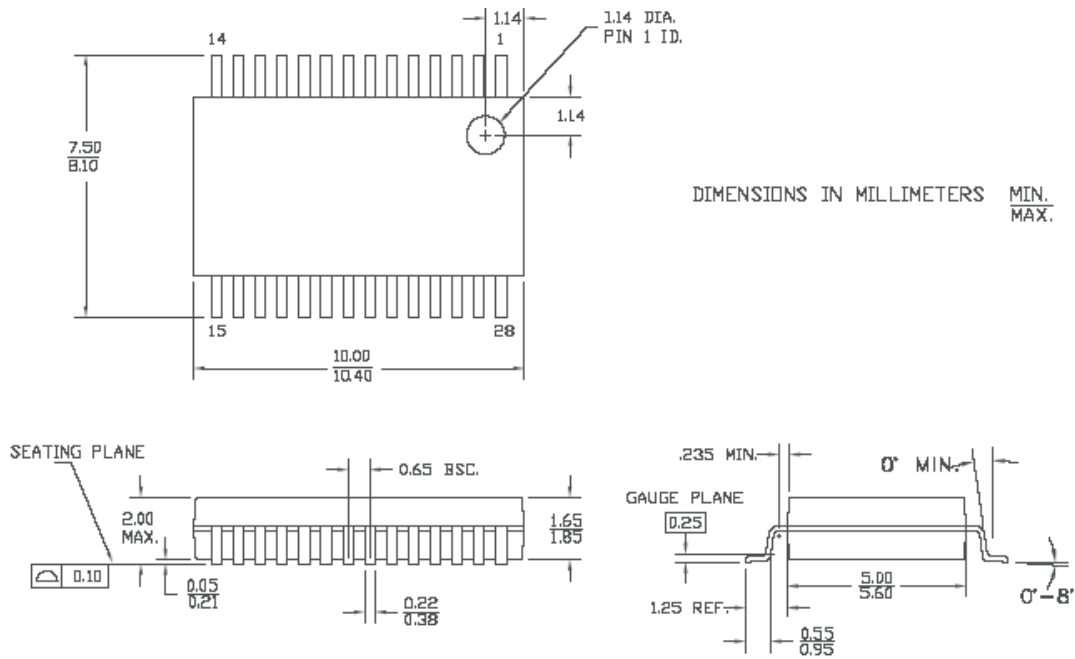
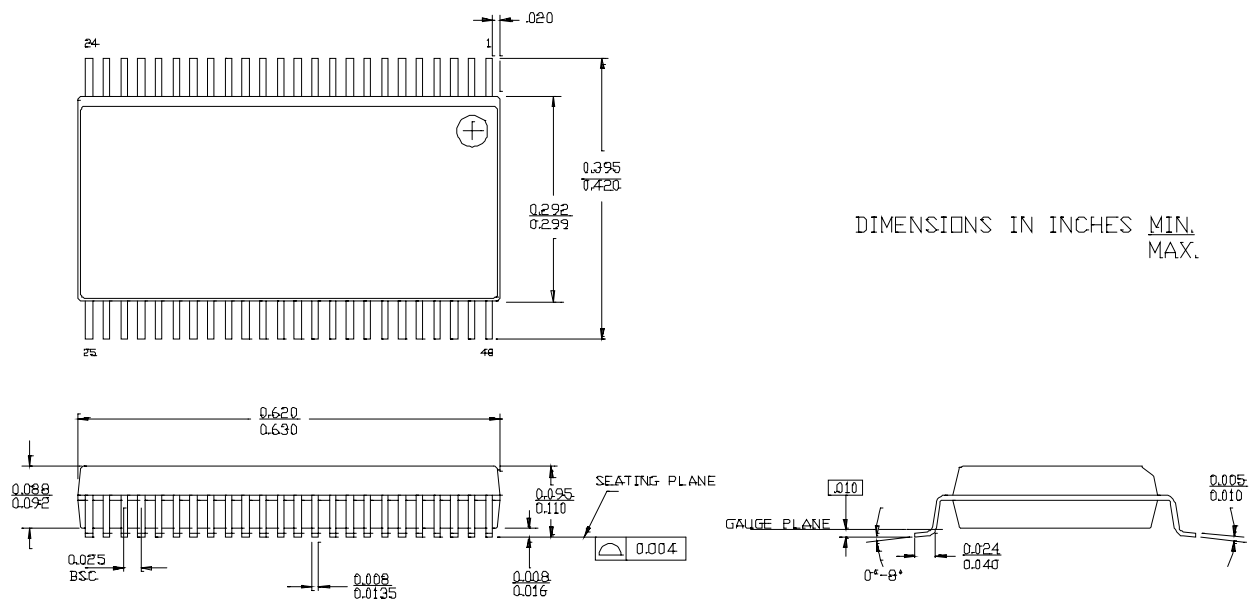

Figure 38: 20-Pin Shrunk Small Outline Package O20



51-85079 *C

Figure 39: 28-Lead (210-Mil) Shrunk Small Outline Package O28



51-85061-C

Figure 40: 48-Lead Shrunk Small Outline Package O48

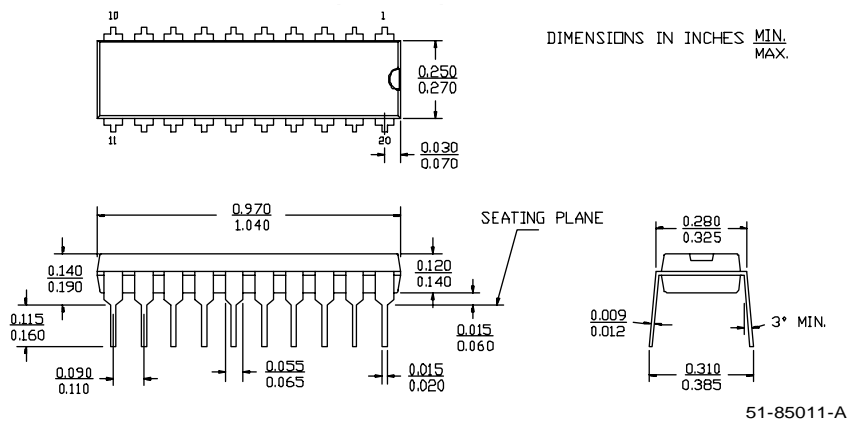

Figure 41: 20-Lead (300-Mil) Molded DIP P5

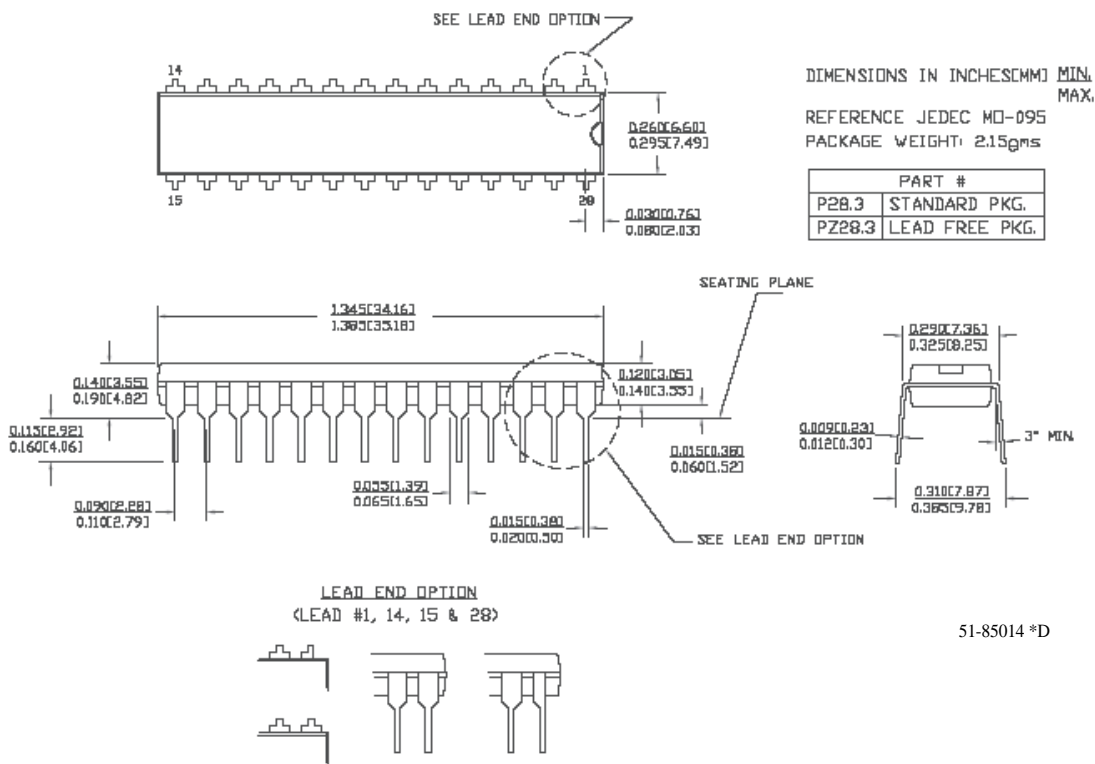

Figure 42: 28-Lead (300-Mil) Molded DIP P21

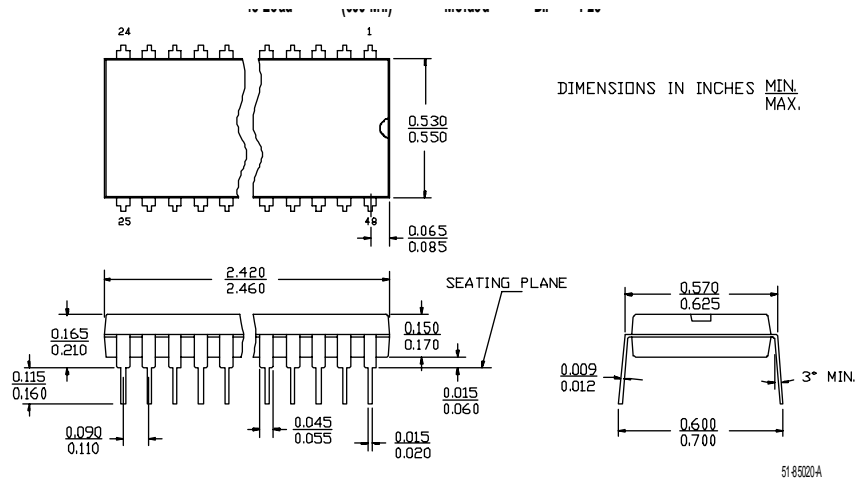

Figure 43: 48-Lead (600-Mil) Molded DIP P25

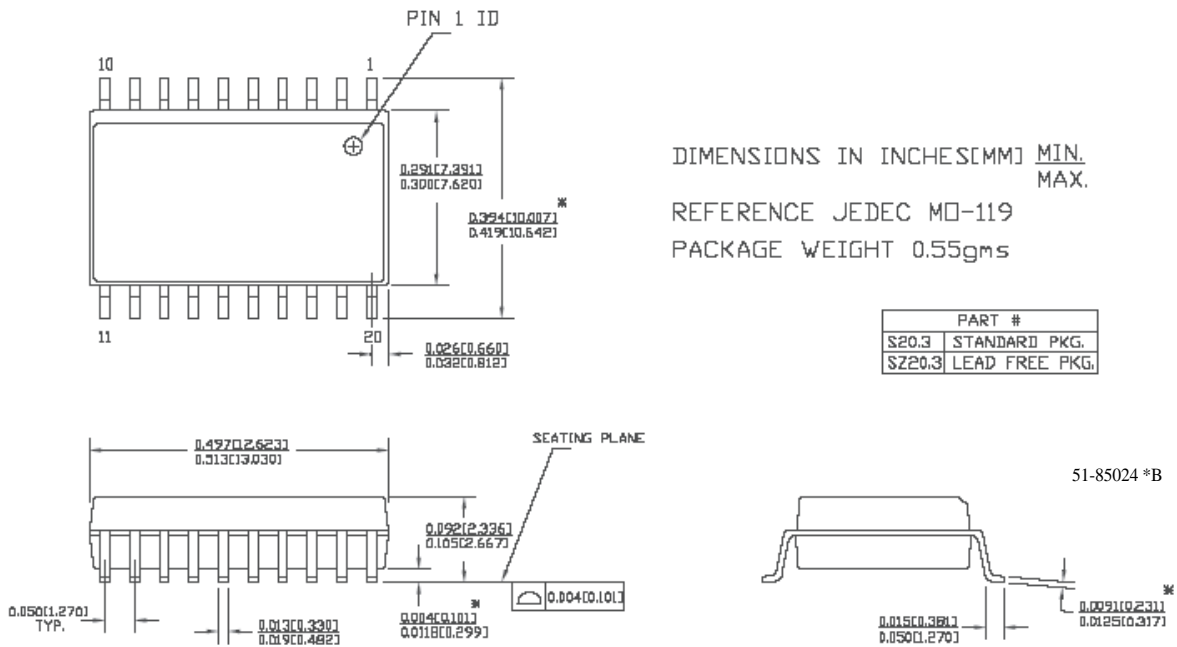

Figure 44: 20-Lead (300-Mil) Molded SOIC S5

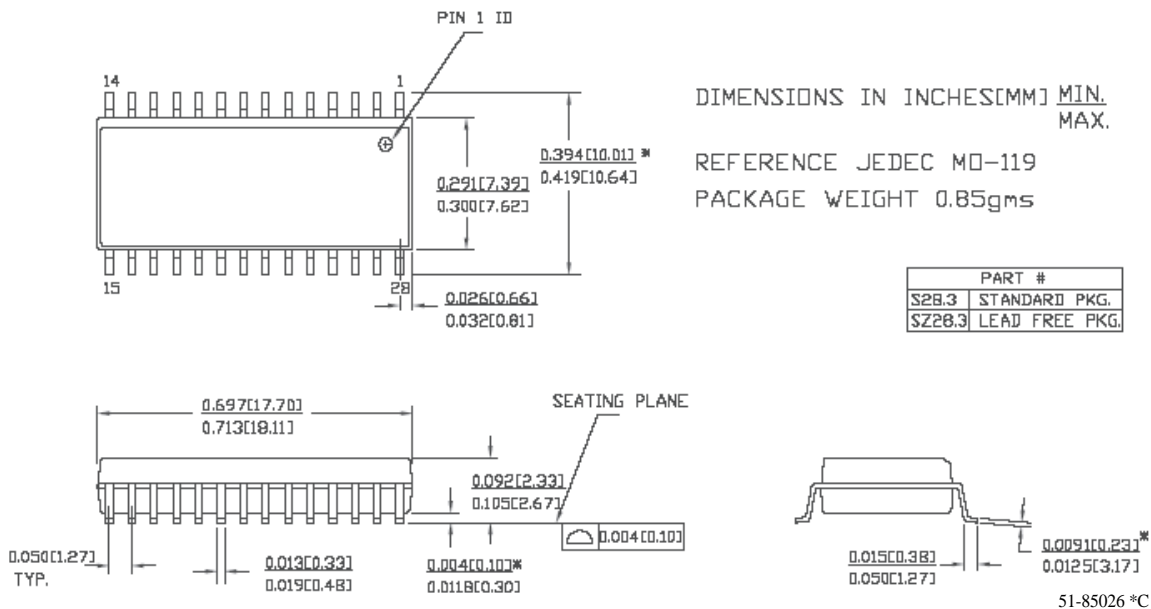

Figure 45: 28-Lead (300-Mil) Molded SOIC S21

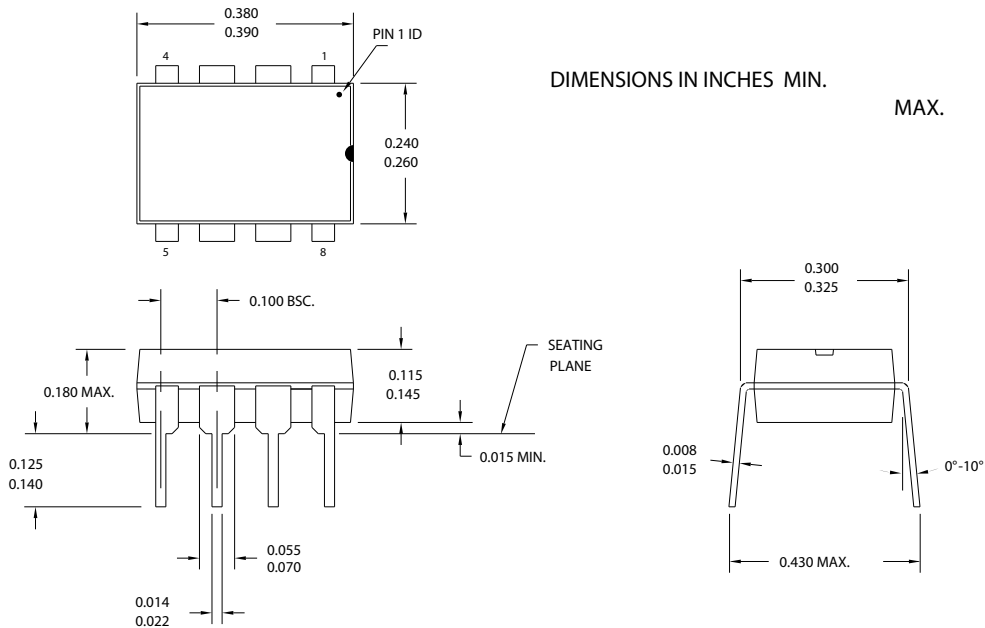

Figure 46: 8-Lead (300-Mil) Molded DIP

14.1 Thermal Impedances per Package

Table 122: Thermal Impedances

Package	Typical Θ_{JA}
8 PDIP	121 C/W
20 PDIP	107 C/W
20 SOIC	80 C/W
20 SSOP	116 C/W
28 PDIP	68 C/W
28 SOIC	72 C/W
28 SSOP	95 C/W
48 PDIP	70 C/W
48 SSOP	69 C/W
44 TQFP	58 C/W

15.0 Ordering Guide

Table 123: Ordering Guide (Leaded)¹

Type	Ordering Code	Flash (KBytes)	RAM (Bytes)	SMP	Temperature Range
8 Pin (300 Mil) Molded DIP	CY8C25122-24PI	4	256	No	Ind. -40C to +85C
20 Pin (300 Mil) Molded DIP	CY8C26233-24PI	8	256	Yes	Ind. -40C to +85C
20 Pin (300 Mil) Molded SOIC	CY8C26233-24SI	8	256	Yes	Ind. -40C to +85C
20 Pin (210 Mil) SSOP	CY8C26233-24PVI	8	256	Yes	Ind. -40C to +85C
28 Pin (300 Mil) Molded DIP	CY8C26443-24PI	16	256	Yes	Ind. -40C to +85C
28 Pin (300 Mil) Molded SOIC	CY8C26443-24SI	16	256	Yes	Ind. -40C to +85C
28 Pin (210 Mil) SSOP	CY8C26443-24PVI	16	256	Yes	Ind. -40C to +85C
48 Pin (600 Mil) Molded DIP	CY8C26643-24PI ²	16	256	Yes	Ind. -40C to +85C
48 Pin (300 Mil) SSOP	CY8C26643-24PVI	16	256	Yes	Ind. -40C to +85C
44 Pin Thin Plastic Quad Flatpack	CY8C26643-24AI	16	256	Yes	Ind. -40C to +85C

- Orders for leaded devices will not be accepted after July 2005.
- 48-PDIP package not offered Pb-Free.

Table 124: Ordering Guide (Pb-Free Denoted with an "X" in Ordering Code)

Type	Ordering Code	Flash (KBytes)	RAM (Bytes)	SMP	Temperature Range
8 Pin (300 Mil) Molded DIP	CY8C25122-24PXI	4	256	No	Ind. -40C to +85C
20 Pin (300 Mil) Molded DIP	CY8C26233-24PXI	8	256	Yes	Ind. -40C to +85C
20 Pin (300 Mil) Molded SOIC	CY8C26233-24SXI	8	256	Yes	Ind. -40C to +85C
20 Pin (300 Mil) Molded SOIC Tape and Reel	CY8C26233-24SXIT	8	256	Yes	Ind. -40C to +85C
20 Pin (210 Mil) SSOP	CY8C26233-24PVXI	8	256	Yes	Ind. -40C to +85C
20 Pin (210 Mil) SSOP Tape and Reel	CY8C26233-24PVXIT	8	256	Yes	Ind. -40C to +85C
28 Pin (300 Mil) Molded DIP	CY8C26443-24PXI	16	256	Yes	Ind. -40C to +85C
28 Pin (300 Mil) Molded SOIC	CY8C26443-24SXI	16	256	Yes	Ind. -40C to +85C
28 Pin (300 Mil) Molded SOIC Tape and Reel	CY8C26443-24SXIT	16	256	Yes	Ind. -40C to +85C
28 Pin (210 Mil) SSOP	CY8C26443-24PVXI	16	256	Yes	Ind. -40C to +85C
28 Pin (210 Mil) SSOP Tape and Reel	CY8C26443-24PVXIT	16	256	Yes	Ind. -40C to +85C
48 Pin (300 Mil) SSOP	CY8C26643-24PVXI	16	256	Yes	Ind. -40C to +85C
48 Pin (300 Mil) SSOP Tape and Reel	CY8C26643-24PVXIT	16	256	Yes	Ind. -40C to +85C
44 Pin Thin Plastic Quad Flatpack	CY8C26643-24AXI	16	256	Yes	Ind. -40C to +85C
44 Pin Thin Plastic Quad Flatpack Tape and Reel	CY8C26643-24AXIT	16	256	Yes	Ind. -40C to +85C



16.0 Document Revision History

Table 125: Document Revision History

Document Title: CY8C25122, CY8C26233, CY8C26443, CY8C26643 Device Data Sheet for Silicon Revision D				
Document Number: 38-12010				
Revision	ECN #	Issue Date	Origin of Change	Description of Change
**	116628	6/17/2002	CMS Cypress Management. New Silicon Revision.	New document to CY Document Control (Revision **). Revision 3.20 for CMS customers.
*A	127231	5/22/2003	HMT.	Implementing new error tracking and document release procedure. Changes in red for Document #: 38-12010 CY Rev. *A CMS Rev. 3.20a. Changes include: --Bit 6 of the VLT_CR register is RW. Should be changed from "RW" to "--." --Analog Output Buffer Control Register ABF_CR Read/Write in Bank 1 table was corrected to Write Only. --Rewrite of section 10.4 Analog Reference Control . --AC Char. Spec. table changed .080 to 80 in "Vdd Rise Rate at Power Up." On features pg. 2, changed "Up to 10 bit DAC" to "Up to 8 bit DAC." --Adding temp. spec. for 24 MHz at beginning of AC/DC Characteristics section and Absolute Maximum Value table. --In AC Operating Spec. table fixed footnote for Output Rise Time minimum. --In AC Operating Spec. table fixed value for External Reset Pulse Width. --Changed uS to us units in tables. --New intro. --In the Analog Reference Control Register, ARF_CR, state 100 for bits 2:0 should be described as "All Analog Off." --Rework title pgs.
*B	127231	5/22/2003	HMT.	Several updates including Thermal Impedances table, 8 PDIP diagram and company address. OSC_CR0 register name.
*C	362598	See ECN	HMT.	Add Pb-Free table. Add "Not Recommended for New Designs" banner. Update package revisions. Fix register typo's.
Distribution: External/Public				
Posting: None				

Looking for pricing, stock, or lifecycle information?

Click below to explore more details on WIN SOURCE:

-  [View CY8C26443-24PVXI on WIN SOURCE](#)
-  [Cypress Semiconductor Corp Information](#)

Optimize Your Supply Chain with WIN SOURCE Solutions

-  Global Sourcing Solution
-  Obsolete Management
-  Cost Control Management
-  Shortage Management
-  Alternative Solution
-  Excess Inventory Management