



**THE DATASHEET OF
MSP430FG4619IPZR**



MSP430FG461x, MSP430CG461x Mixed-Signal Microcontrollers

1 Device Overview

1.1 Features

- Low Supply-Voltage Range: 1.8 V to 3.6 V
- Ultra-Low Power Consumption
 - Active Mode: 400 μ A at 1 MHz, 2.2 V
 - Standby Mode: 1.3 μ A
 - Off Mode (RAM Retention): 0.22 μ A
- Five Power-Saving Modes
- Wakeup From Standby Mode in Less Than 6 μ s
- 16-Bit RISC Architecture, Extended Memory, 125-ns Instruction Cycle Time
- Three-Channel Internal DMA
- 12-Bit Analog-to-Digital Converter (ADC) With Internal Reference, Sample-and-Hold and Autoscan Feature
- Three Configurable Operational Amplifiers
- Dual 12-Bit Digital-to-Analog Converters (DACs) With Synchronization
- 16-Bit Timer_A With Three Capture/Compare Registers
- 16-Bit Timer_B With Seven Capture/Compare-With-Shadow Registers
- On-Chip Comparator
- Supply Voltage Supervisor and Monitor With Programmable Level Detection
- Serial Communication Interface (USART1), Select Asynchronous UART or Synchronous SPI by Software
- Universal Serial Communication Interface
 - Enhanced UART Supports Automatic Baud-Rate Detection
 - IrDA Encoder and Decoder
 - Synchronous SPI
 - I²C
- Serial Onboard Programming, Programmable Code Protection by Security Fuse
- Brownout Detector
- Basic Timer With Real-Time Clock (RTC) Feature
- Integrated LCD Driver up to 160 Segments With Regulated Charge Pump
- [Section 3](#) Summarizes the Available Family Members
 - MSP430FG4616, MSP430FG4616 92KB+256B of Flash or ROM 4KB of RAM
 - MSP430FG4617, MSP430CG4617 92KB+256B of Flash or ROM 8KB of RAM
 - MSP430FG4618, MSP430CG4618 116KB+256B of Flash or ROM 8KB of RAM
 - MSP430FG4619, MSP430CG4619 120KB+256B of Flash or ROM 4KB of RAM
- For Complete Module Descriptions, see the *MSP430x4xx Family User's Guide* ([SLAU056](#))

1.2 Applications

- Portable Medical Applications
- E-Meter Applications

1.3 Description

The TI MSP430™ family of ultra-low-power microcontrollers consists of several devices featuring different sets of peripherals targeted for various applications. The architecture, combined with five low-power modes, is optimized to achieve extended battery life in portable measurement applications. The device features a powerful 16-bit RISC CPU, 16-bit registers, and constant generators that contribute to maximum code efficiency. The digitally controlled oscillator (DCO) allows the device to wake up from low-power modes to active mode in less than 6 μ s.

The MSP430xG461x series are microcontroller configurations with two 16-bit timers, a high-performance 12-bit ADC, dual 12-bit DACs, three configurable operational amplifiers, one universal serial communication interface (USCI), one universal synchronous/asynchronous communication interface (USART), DMA, 80 I/O pins, and a segment liquid crystal display (LCD) driver with regulated charge pump.



Device Information⁽¹⁾

PART NUMBER	PACKAGE	BODY SIZE ⁽²⁾
MSP430FG4619IPZ	LQFP (100)	14 mm x 14 mm
MSP430FG4619IZQW	MicroStar Junior™ BGA (113)	7 mm x 7 mm

(1) For the most current part, package, and ordering information for all available devices, see the *Package Option Addendum* in [Section 8](#), or see the TI website at www.ti.com.

(2) The sizes shown here are approximations. For the package dimensions with tolerances, see the *Mechanical Data* in [Section 8](#).

1.4 Functional Block Diagram

Figure 1-1 shows the functional block diagram.

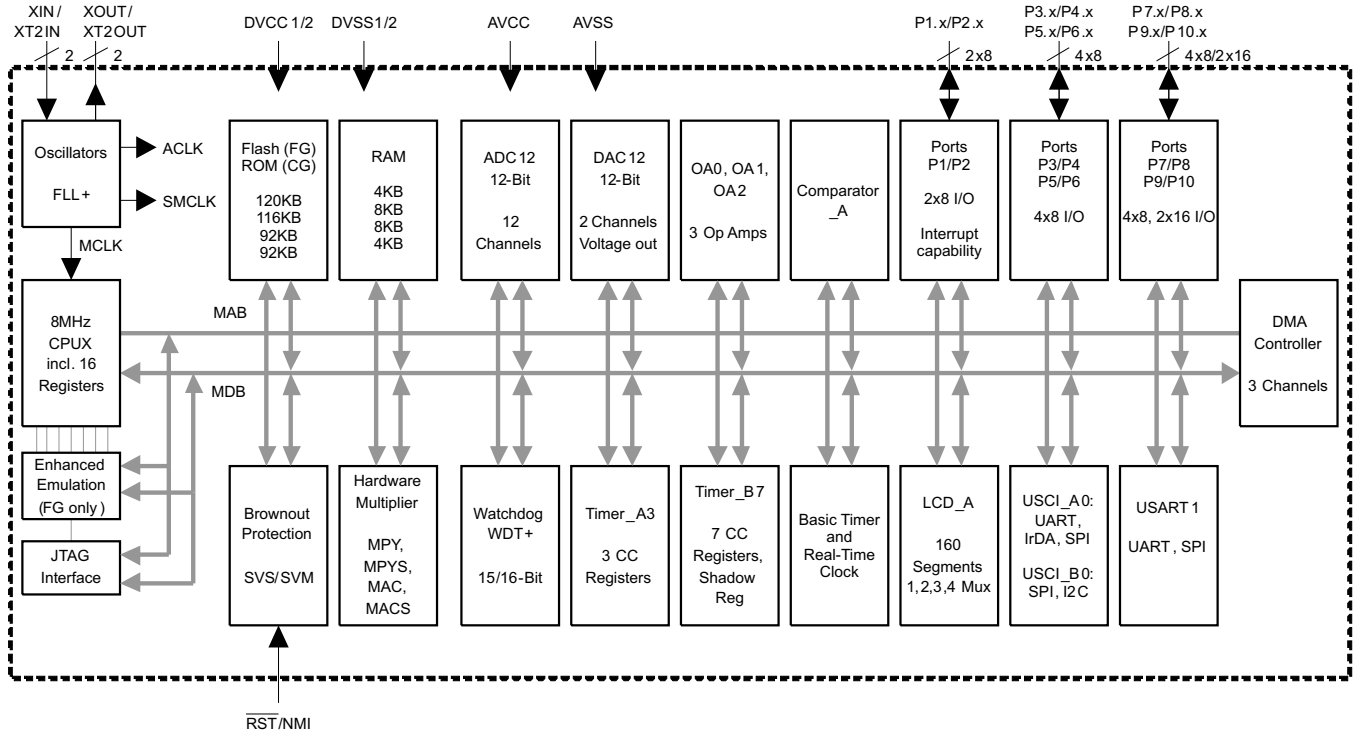

Figure 1-1. Functional Block Diagram

Table of Contents

1	Device Overview	1	5.30	12-Bit ADC, Timing Parameters	37
1.1	Features	1	5.31	12-Bit ADC, Linearity Parameters	37
1.2	Applications	1	5.32	12-Bit ADC, Temperature Sensor and Built-In V_{MID}	38
1.3	Description	1			38
1.4	Functional Block Diagram	2	5.33	12-Bit DAC, Supply Specifications	38
2	Revision History	4	5.34	12-Bit DAC, Linearity Specifications	39
3	Device Comparison	5	5.35	12-Bit DAC, Output Specifications	41
4	Terminal Configuration and Functions	6	5.36	12-Bit DAC, Reference Input Specifications	41
4.1	Pin Diagrams	6	5.37	12-Bit DAC, Dynamic Specifications	42
4.2	Signal Descriptions	8	5.38	12-Bit DAC, Dynamic Specifications Continued	43
5	Specifications	14	5.39	Operational Amplifier OA, Supply Specifications	44
5.1	Absolute Maximum Ratings	14	5.40	Operational Amplifier OA, Input/Output Specifications	44
5.2	ESD Ratings	14	5.41	Operational Amplifier OA, Dynamic Specifications	45
5.3	Recommended Operating Conditions	14	5.42	Operational Amplifier OA, Typical Characteristics	45
5.4	Supply Current Into AV_{CC} + DV_{CC} Excluding External Current	16	5.43	Operational Amplifier OA Feedback Network, Noninverting Amplifier Mode (OAF _{Cx} = 4)	46
5.5	Thermal Characteristics	17	5.44	Operational Amplifier OA Feedback Network, Inverting Amplifier Mode (OAF _{Cx} = 6)	46
5.6	Schmitt-Trigger Inputs – Ports P1 to P10, \overline{RST}/NMI , JTAG (TCK, TMS, TDI/TCLK, TDO/TDI)	18	5.45	Flash Memory (FG461x Devices Only)	47
5.7	Inputs P _{x.x} , TAx, TBX	18	5.46	JTAG Interface	47
5.8	Leakage Current – Ports P1 to P10	18	5.47	JTAG Fuse	47
5.9	Outputs – Ports P1 to P10	18	6	Detailed Description	48
5.10	Output Frequency	19	6.1	CPU	48
5.11	Typical Characteristics – Outputs	20	6.2	Instruction Set	49
5.12	Wake-up Timing From LPM3	21	6.3	Operating Modes	50
5.13	RAM	21	6.4	Interrupt Vector Addresses	51
5.14	LCD_A	21	6.5	Special Function Registers (SFRs)	52
5.15	Comparator_A	22	6.6	Memory Organization	54
5.16	Typical Characteristics – Comparator_A	23	6.7	Bootstrap Loader (BSL)	55
5.17	POR, BOR	24	6.8	Flash Memory	55
5.18	SVS (Supply Voltage Supervisor and Monitor)	25	6.9	Peripherals	55
5.19	DCO	27	6.10	Input/Output Schematics	65
5.20	Crystal Oscillator, LFXT1 Oscillator	29	7	Device and Documentation Support	100
5.21	Crystal Oscillator, XT2 Oscillator	29	7.1	Device Support	100
5.22	USCI (UART Mode)	29	7.2	Documentation Support	103
5.23	USCI (SPI Master Mode)	30	7.3	Related Links	103
5.24	USCI (SPI Slave Mode)	30	7.4	Community Resources	104
5.25	USCI (I ² C Mode)	33	7.5	Trademarks	104
5.26	USART1	33	7.6	Electrostatic Discharge Caution	104
5.27	12-Bit ADC, Power Supply and Input Range Conditions	34	7.7	Export Control Notice	104
5.28	12-Bit ADC, External Reference	34	7.8	Glossary	104
5.29	12-Bit ADC, Built-In Reference	35	8	Mechanical, Packaging, and Orderable Information	105

2 Revision History

NOTE: Page numbers for previous revisions may differ from page numbers in the current version.

Changes from March 2, 2011 to June 19, 2015	Page
• Document format and organization changes throughout, including the addition of section numbering	1
• Added <i>Device Information</i> table	2
• Moved functional block diagram to Section 1.4	2
• Added Section 3, Device Comparison	5
• Added signal names to ZQW pinout figure	7
• Changed table note that starts "Segments S0 through S3 are disabled when..."	8
• Added row for unassigned ball locations on ZQW package	13
• Added Section 5 and moved all electrical specifications to it	14
• Added Section 5.2, ESD Ratings	14
• In <i>Recommended Operating Conditions</i> , added test conditions for TYP values	14
• Added Section 5.5, Thermal Characteristics	17
• Changed table note that starts "Segments S0 through S3 are disabled when..."	21
• Changed the value of DAC12_xDAT from 7F7h to F7Fh in Figure 5-33	43
• Added Table 6-19 and moved P4.6 and P4.7 from Table 6-18 to insert correct LCDS32 control bit name	75
• Added Table 6-29 and moved P7.2 and P7.3 from Table 6-28 to insert correct LCDS28 control bit name	88
• Added Table 6-31 and moved P7.6 and P7.7 from Table 6-30 to insert correct LCDS24 control bit name	89
• Added Table 6-33 and moved P8.2 to P8.5 from Table 6-32 to insert correct LCDS20 control bit name	90
• Added Table 6-36 and moved P9.2 to P9.5 from Table 6-35 to insert correct LCDS12 control bit name	92
• Corrected LCD segment numbers in PIN NAME column of Table 6-36	92
• Added Table 6-37 and moved P9.6 and P9.7 from Table 6-35 to insert correct LCDS8 control bit name	93
• Corrected LCD segment numbers in PIN NAME column of Table 6-37	93
• Corrected LCD segment numbers in PIN NAME and FUNCTION columns of Table 6-38	94
• Added Table 6-39 and moved P10.2 to P10.5 from Table 6-38 to insert correct LCDS4 control bit name	94
• Added Section 7 and moved Trademarks and ESD Caution sections to it	100
• Added Section 8	105

3 Device Comparison

Table 3-1 summarizes the available family members.

Table 3-1. Device Comparison⁽¹⁾⁽²⁾

DEVICE	FLASH (KB)	ROM (KB)	RAM (KB)	EEM	Timer_A	Timer_B	ADC12 (Channels)	OP AMP	DAC12 (Channels)	COMP_A (Channels)	USART	USCI	I/O	PACKAGE
MSP430FG4619	120	–	4	1	TA3	TB7	12	3	2	2	1	A0, B0	80	PZ 100 ZQW 113
MSP430FG4618	116	–	8	1	TA3	TB7	12	3	2	2	1	A0, B0	80	PZ 100 ZQW 113
MSP430FG4617	92	–	8	1	TA3	TB7	12	3	2	2	1	A0, B0	80	PZ 100 ZQW 113
MSP430FG4616	92	–	4	1	TA3	TB7	12	3	2	2	1	A0, B0	80	PZ 100 ZQW 113
MSP430CG4619	–	120	4	–	TA3	TB7	12	3	2	2	1	A0, B0	80	PZ 100 ZQW 113
MSP430CG4618	–	116	8	–	TA3	TB7	12	3	2	2	1	A0, B0	80	PZ 100 ZQW 113
MSP430CG4617	–	92	8	–	TA3	TB7	12	3	2	2	1	A0, B0	80	PZ 100 ZQW 113
MSP430CG4616	–	92	4	–	TA3	TB7	12	3	2	2	1	A0, B0	80	PZ 100 ZQW 113

- (1) For the most current device, package, and ordering information for all available devices, see the *Package Option Addendum* in Section 8, or see the TI website at www.ti.com.
(2) Package drawings, thermal data, and symbolization are available at www.ti.com/packaging.

4 Terminal Configuration and Functions

4.1 Pin Diagrams

Figure 4-1 shows the pinout for the 100-pin PZ package.

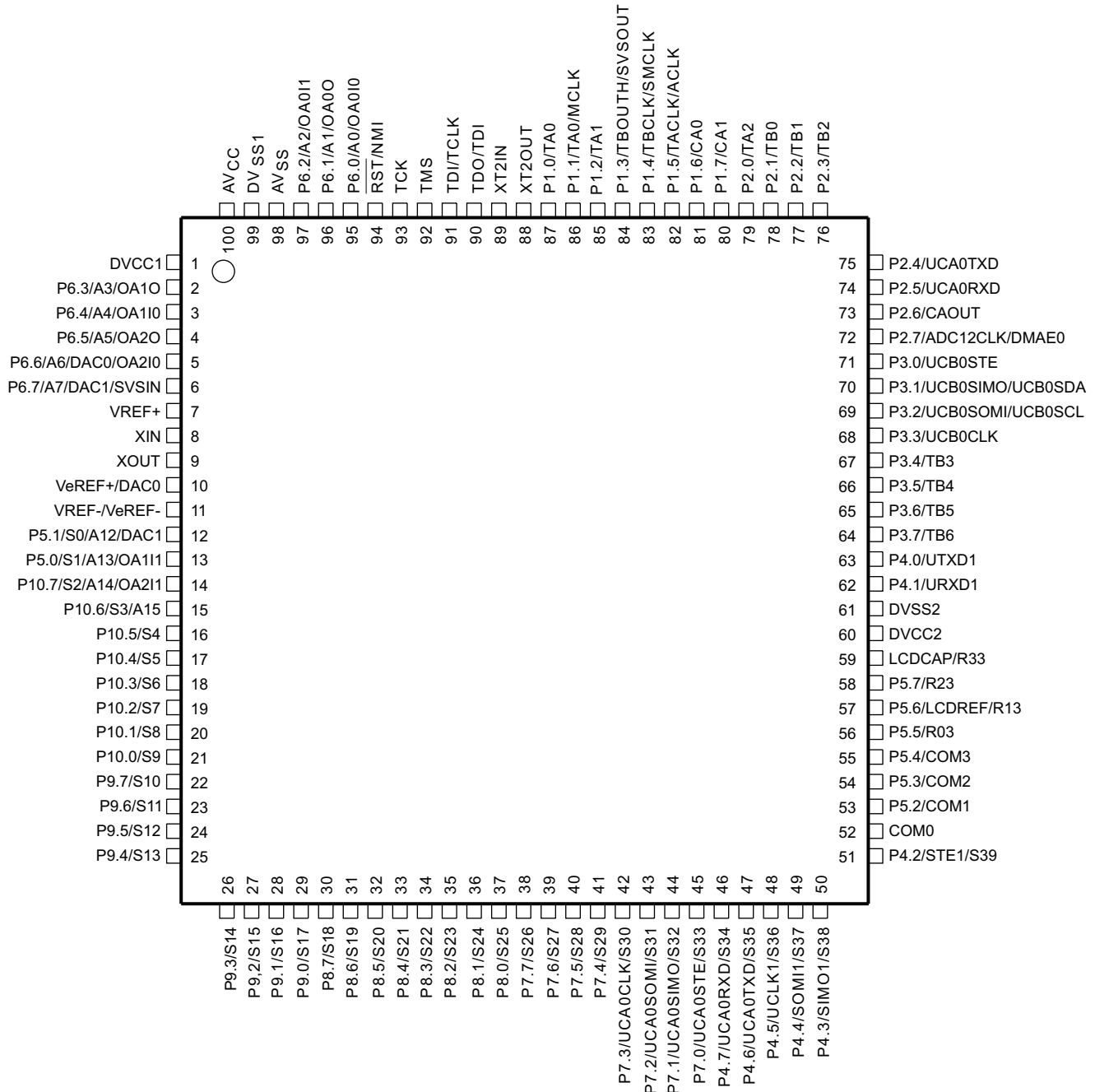
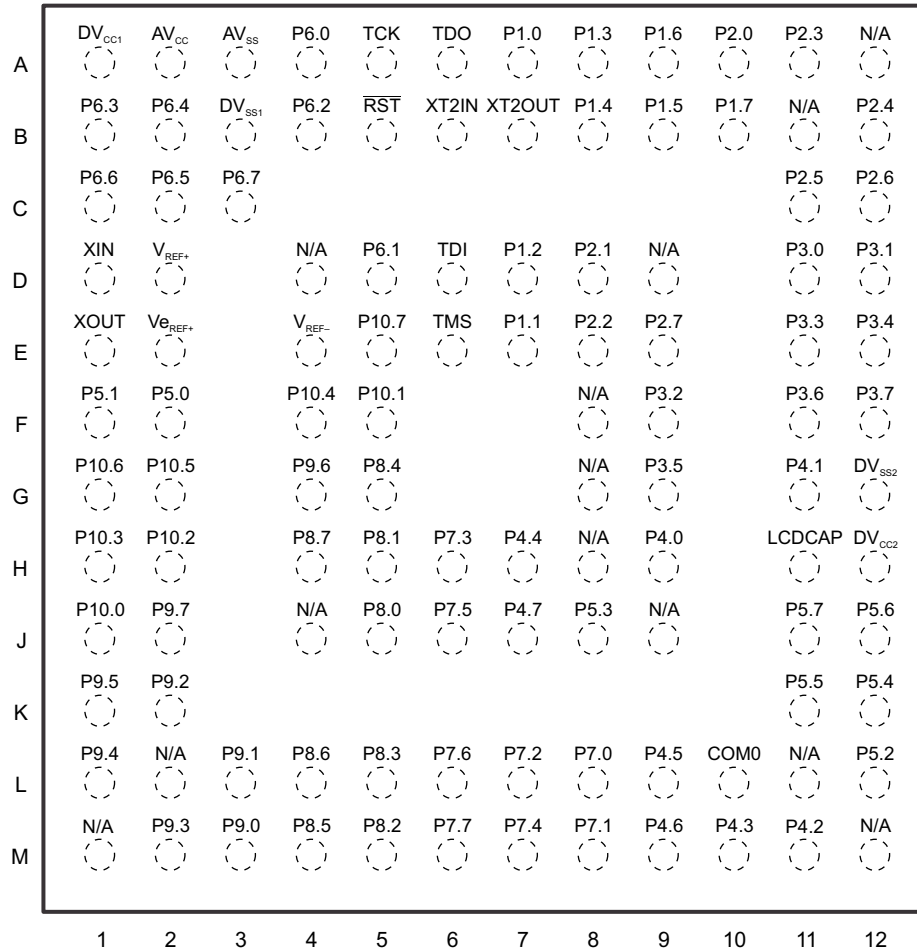

Figure 4-1. 100-Pin PZ Package (Top View)

Figure 4-2 shows the pinout for the 113-pin ZQW package. This figure shows only the default pin assignments; for all pin assignments, see Table 4-1.



N/A = Not Assigned. All unassigned ball locations on the ZQW package should be electrically tied to the ground supply. The shortest ground return path to the device should be established to ball location B3, DV_{SS1}.

Figure 4-2. 113-Pin ZQW Package (Top View)

4.2 Signal Descriptions

Table 4-1 describes the signals for all device variants and package options.

Table 4-1. Signal Descriptions

SIGNAL NAME	PIN NO.		I/O	DESCRIPTION
	PZ	ZQW		
DV _{CC1}	1	A1		Digital supply voltage, positive terminal
P6.3 A3 OA1O	2	B1	I/O	General-purpose digital I/O Analog input A3 for 12-bit ADC OA1 output
P6.4 A4 OA1I0	3	B2	I/O	General-purpose digital I/O Analog input A4 for 12-bit ADC OA1 input multiplexer on + terminal and – terminal
P6.5 A5 OA2O	4	C2	I/O	General-purpose digital I/O Analog input A5 for 12-bit ADC OA2 output
P6.6 A6 DAC0 OA2I0	5	C1	I/O	General-purpose digital I/O Analog input A6 for 12-bit ADC DAC12.0 output OA2 input multiplexer on + terminal and – terminal
P6.7 A7 DAC1 SVSIN	6	C3	I/O	General-purpose digital I/O Analog input A7 for 12-bit ADC DAC12.1 output Analog input to brownout, supply voltage supervisor
V _{REF+}	7	D2	O	Output of positive terminal of the reference voltage in the ADC
XIN	8	D1	I	Input port for crystal oscillator XT1. Standard or watch crystals can be connected.
XOUT	9	E1	O	Output terminal of crystal oscillator XT1
V _{REF+} DAC0	10	E2	I/O	Input for an external reference voltage to the ADC DAC12.0 output
V _{REF} V _{REF-}	11	E4	I	Internal reference voltage, negative terminal for the ADC reference voltage External applied reference voltage, negative terminal for the ADC reference voltage
P5.1 S0 ⁽¹⁾ A12 DAC1	12	F1	I/O	General-purpose digital I/O LCD segment output 0 Analog input A12 for 12-bit ADC DAC12.1 output
P5.0 S1 ⁽¹⁾ A13 OA1I1	13	F2	I/O	General-purpose digital I/O LCD segment output 1 Analog input A13 for 12-bit ADC OA1 input multiplexer on + terminal and – terminal
P10.7 S2 ⁽¹⁾ A14 OA2I1	14	E5	I/O	General-purpose digital I/O LCD segment output 2 Analog input A14 for 12-bit ADC OA2 input multiplexer on + terminal and – terminal
P10.6 S3 ⁽¹⁾ A15	15	G1	I/O	General-purpose digital I/O LCD segment output 3 Analog input A15 to 12-bit ADC

(1) Segments S0 through S3 are disabled when the LCD charge pump feature is enabled (LCDPEN = 1) and, therefore, cannot be used together with the LCD charge pump. On the MSP430xG461x devices only, S0 through S3 are also disabled if VLCDEXT = 1. This setting is typically used to apply an external LCD voltage supply to the LCDCAP terminal. For these devices, set LCDPEN = 0, VLCDEXT = 0, and VLCDEXT > 0 to enable an external LCD voltage supply to be applied to the LCDCAP terminal.

Table 4-1. Signal Descriptions (continued)

SIGNAL NAME	PIN NO.		I/O	DESCRIPTION
	PZ	ZQW		
P10.5 S4	16	G2	I/O	General-purpose digital I/O LCD segment output 4
P10.4 S5	17	F4	I/O	General-purpose digital I/O LCD segment output 5
P10.3 S6	18	H1	I/O	General-purpose digital I/O LCD segment output 6
P10.2 S7	19	H2	I/O	General-purpose digital I/O LCD segment output 7
P10.1 S8	20	F5	I/O	General-purpose digital I/O LCD segment output 8
P10.0 S9	21	J1	I/O	General-purpose digital I/O LCD segment output 9
P9.7 S10	22	J2	I/O	General-purpose digital I/O LCD segment output 10
P9.6 S11	23	G4	I/O	General-purpose digital I/O LCD segment output 11
P9.5 S12	24	K1	I/O	General-purpose digital I/O LCD segment output 12
P9.4 S13	25	L1	I/O	General-purpose digital I/O LCD segment output 13
P9.3 S14	26	M2	I/O	General-purpose digital I/O LCD segment output 14
P9.2 S15	27	K2	I/O	General-purpose digital I/O LCD segment output 15
P9.1 S16	28	L3	I/O	General-purpose digital I/O LCD segment output 16
P9.0 S17	29	M3	I/O	General-purpose digital I/O LCD segment output 17
P8.7 S18	30	H4	I/O	General-purpose digital I/O LCD segment output 18
P8.6 S19	31	L4	I/O	General-purpose digital I/O LCD segment output 19
P8.5 S20	32	M4	I/O	General-purpose digital I/O LCD segment output 20
P8.4 S21	33	G5	I/O	General-purpose digital I/O LCD segment output 21
P8.3 S22	34	L5	I/O	General-purpose digital I/O LCD segment output 22
P8.2 S23	35	M5	I/O	General-purpose digital I/O LCD segment output 23
P8.1 S24	36	H5	I/O	General-purpose digital I/O LCD segment output 24
P8.0 S25	37	J5	I/O	General-purpose digital I/O LCD segment output 25
P7.7 S26	38	M6	I/O	General-purpose digital I/O LCD segment output 26

Table 4-1. Signal Descriptions (continued)

SIGNAL NAME	PIN NO.		I/O	DESCRIPTION
	PZ	ZQW		
P7.6 S27	39	L6	I/O	General-purpose digital I/O LCD segment output 27
P7.5 S28	40	J6	I/O	General-purpose digital I/O LCD segment output 28
P7.4 S29	41	M7	I/O	General-purpose digital I/O LCD segment output 29
P7.3 UCA0CLK S30	42	H6	I/O	General-purpose digital I/O External clock input – USCI_A0 in UART or SPI mode, Clock output – USCI_A0 in SPI mode LCD segment 30
P7.2 UCA0SOMI S31	43	L7	I/O	General-purpose digital I/O Slave out/master in of USCI_A0 in SPI mode LCD segment output 31
P7.1 UCA0SIMO S32	44	M8	I/O	General-purpose digital I/O Slave in/master out of USCI_A0 in SPI mode LCD segment output 32
P7.0 UCA0STE S33	45	L8	I/O	General-purpose digital I/O Slave transmit enable – USCI_A0 in SPI mode LCD segment output 33
P4.7 UCA0RXD S34	46	J7	I/O	General-purpose digital I/O Receive data in – USCI_A0 in UART or IrDA mode LCD segment output 34
P4.6 UCA0TXD S35	47	M9	I/O	General-purpose digital I/O Transmit data out – USCI_A0 in UART or IrDA mode LCD segment output 35
P4.5 UCLK1 S36	48	L9	I/O	General-purpose digital I/O External clock input – USART1 in UART or SPI mode, Clock output – USART1 in SPI MODE LCD segment output 36
P4.4 SOMI1 S37	49	H7	I/O	General-purpose digital I/O Slave out/master in of USART1 in SPI mode LCD segment output 37
P4.3 SIMO1 S38	50	M10	I/O	General-purpose digital I/O Slave in/master out of USART1 in SPI mode LCD segment output 38
P4.2 STE1 S39	51	M11	I/O	General-purpose digital I/O Slave transmit enable – USART1 in SPI mode LCD segment output 39
COM0	52	L10	O	Common output, COM0 for LCD backplanes
P5.2 COM1	53	L12	I/O	General-purpose digital I/O Common output, COM1 for LCD backplanes
P5.3 COM2	54	J8	I/O	General-purpose digital I/O Common output, COM2 for LCD backplanes
P5.4 COM3	55	K12	I/O	General-purpose digital I/O Common output, COM3 for LCD backplanes
P5.5 R03	56	K11	I/O	General-purpose digital I/O Input port of lowest analog LCD level (V5)

Table 4-1. Signal Descriptions (continued)

SIGNAL NAME	PIN NO.		I/O	DESCRIPTION
	PZ	ZQW		
P5.6 LCDREF R13	57	J12	I/O	General-purpose digital I/O External reference voltage input for regulated LCD voltage Input port of third most positive analog LCD level (V4 or V3)
P5.7 R23	58	J11	I/O	General-purpose digital I/O Input port of second most positive analog LCD level (V2)
LDCAP R33	59	H11	I	LCD capacitor connection Input/output port of most positive analog LCD level (V1)
DV _{CC2}	60	H12		Digital supply voltage, positive terminal
DV _{SS2}	61	G12		Digital supply voltage, negative terminal
P4.1 URXD1	62	G11	I/O	General-purpose digital I/O Receive data in – USART1 in UART mode
P4.0 UTXD1	63	H9	I/O	General-purpose digital I/O Transmit data out – USART1 in UART mode
P3.7 TB6	64	F12	I/O	General-purpose digital I/O Timer_B7 CCR6. Capture: CCI6A/CCI6B input, compare: Out6 output
P3.6 TB5	65	F11	I/O	General-purpose digital I/O Timer_B7 CCR5. Capture: CCI5A/CCI5B input, compare: Out5 output
P3.5 TB4	66	G9	I/O	General-purpose digital I/O Timer_B7 CCR4. Capture: CCI4A/CCI4B input, compare: Out4 output
P3.4 TB3	67	E12	I/O	General-purpose digital I/O Timer_B7 CCR3. Capture: CCI3A/CCI3B input, compare: Out3 output
P3.3 UCB0CLK	68	E11	I/O	General-purpose digital I/O External clock input – USCI_B0 in UART or SPI mode, Clock output – USCI_B0 in SPI mode
P3.2 UCB0SOMI UCB0SCL	69	F9	I/O	General-purpose digital I/O Slave out/master in of USCI_B0 in SPI mode I ² C clock – USCI_B0 in I ² C mode
P3.1 UCB0SIMO UCB0SDA	70	D12	I/O	General-purpose digital I/O Slave in/master out of USCI_B0 in SPI mode I ² C data – USCI_B0 in I ² C mode
P3.0 UCB0STE	71	D11	I/O	General-purpose digital I/O Slave transmit enable – USCI_B0 in SPI mode
P2.7 ADC12CLK DMAE0	72	E9	I/O	General-purpose digital I/O Conversion clock for 12-bit ADC DMA channel 0 external trigger
P2.6 CAOUT	73	C12	I/O	General-purpose digital I/O Comparator_A output
P2.5 UCA0RXD	74	C11	I/O	General-purpose digital I/O Receive data in – USCI_A0 in UART or IrDA mode
P2.4 UCA0TXD	75	B12	I/O	General-purpose digital I/O Transmit data out – USCI_A0 in UART or IrDA mode
P2.3 TB2	76	A11	I/O	General-purpose digital I/O Timer_B7 CCR2. Capture: CCI2A/CCI2B input, compare: Out2 output
P2.2 TB1	77	E8	I/O	General-purpose digital I/O Timer_B7 CCR1. Capture: CCI1A/CCI1B input, compare: Out1 output
P2.1 TB0	78	D8	I/O	General-purpose digital I/O Timer_B7 CCR0. Capture: CCI0A/CCI0B input, compare: Out0 output

Table 4-1. Signal Descriptions (continued)

SIGNAL NAME	PIN NO.		I/O	DESCRIPTION
	PZ	ZQW		
P2.0 TA2	79	A10	I/O	General-purpose digital I/O Timer_A Capture: CCI2A input, compare: Out2 output
P1.7 CA1	80	B10	I/O	General-purpose digital I/O Comparator_A input
P1.6 CA0	81	A9	I/O	General-purpose digital I/O Comparator_A input
P1.5 TACLK ACLK	82	B9	I/O	General-purpose digital I/O Timer_A, clock signal TACLK input ACLK output (divided by 1, 2, 4, or 8)
P1.4 TBCLK SMCLK	83	B8	I/O	General-purpose digital I/O Input clock TBCLK – Timer_B7 Submain system clock SMCLK output
P1.3 TBOUTH SVSOUT	84	A8	I/O	General-purpose digital I/O Switch all PWM digital output ports to high impedance – Timer_B7 TB0 to TB6 SVS: output of SVS comparator
P1.2 TA1	85	D7	I/O	General-purpose digital I/O Timer_A, Capture: CCI1A input, compare: Out1 output
P1.1 TA0 MCLK	86	E7	I/O	General-purpose digital I/O Timer_A. Capture: CCI0B input. Note: TA0 is only an input on this pin. BSL receive. MCLK output
P1.0 TA0	87	A7	I/O	General-purpose digital I/O Timer_A. Capture: CCI0A input, compare: Out0 output. BSL transmit.
XT2OUT	88	B7	O	Output terminal of crystal oscillator XT2
XT2IN	89	B6	I	Input port for crystal oscillator XT2. Only standard crystals can be connected.
TDO TDI	90	A6	I/O	Test data output port. TDO/TDI data output. Programming data input terminal
TDI TCLK	91	D6	I	Test data input Test clock input. The device protection fuse is connected to TDI/TCLK.
TMS	92	E6	I	Test mode select. TMS is used as an input port for device programming and test.
TCK	93	A5	I	Test clock. TCK is the clock input port for device programming and test.
RST NMI	94	B5	I	Reset input Nonmaskable interrupt input port
P6.0 A0 OA0I0	95	A4	I/O	General-purpose digital I/O Analog input A0 for 12-bit ADC OA0 input multiplexer on + terminal and – terminal
P6.1 A1 OA0O	96	D5	I/O	General-purpose digital I/O Analog input A1 for 12-bit ADC OA0 output
P6.2 A2 OA0I1	97	B4	I/O	General-purpose digital I/O Analog input A2 for 12-bit ADC OA0 input multiplexer on + terminal and – terminal
AVSS	98	A3		Analog supply voltage, negative terminal. Supplies SVS, brownout, oscillator, Comparator_A, port 1
DV _{SS1}	99	B3		Digital supply voltage, negative terminal
AV _{CC}	100	A2		Analog supply voltage, positive terminal. Supplies SVS, brownout, oscillator, Comparator_A, port 1. Do not power up before powering DV _{CC1} and DV _{CC2} .

Table 4-1. Signal Descriptions (continued)

SIGNAL NAME	PIN NO.		I/O	DESCRIPTION
	PZ	ZQW		
Not Assigned	–	A12, B11, D4, D9, F8, G8, H8, J4, J9, L2, L11, M1, M12	–	All unassigned ball locations on the ZQW package should be electrically tied to the ground supply. The shortest ground return path to the device should be established to ball location B3, DV _{SS1} .

5 Specifications

5.1 Absolute Maximum Ratings⁽¹⁾

over operating free-air temperature range (unless otherwise noted)

		MIN	MAX	UNIT
Voltage applied at V_{CC} to V_{SS}		-0.3	4.1	V
Voltage applied to any pin ⁽²⁾		-0.3	$V_{CC} + 0.3$	V
Diode current at any device terminal			± 2	mA
Storage temperature, T_{stg}	Unprogrammed device	-55	105	°C
	Programmed device	-40	85	

- (1) Stresses beyond those listed under *Absolute Maximum Ratings* may cause permanent damage to the device. These are stress ratings only, and functional operation of the device at these or any other conditions beyond those indicated under *Recommended Operating Conditions* is not implied. Exposure to absolute-maximum-rated conditions for extended periods may affect device reliability.
- (2) All voltages are referenced to V_{SS} . The JTAG fuse-blow voltage, V_{FB} , is allowed to exceed the absolute maximum rating. The voltage is applied to the TDI/TCLK pin when blowing the JTAG fuse.

5.2 ESD Ratings

		VALUE	UNIT
$V_{(ESD)}$ Electrostatic discharge	Human-body model (HBM), per ANSI/ESDA/JEDEC JS-001 ⁽¹⁾	± 1000	V
	Charged-device model (CDM), per JEDEC specification JESD22-C101 ⁽²⁾	± 250	

- (1) JEDEC document JEP155 states that 500-V HBM allows safe manufacturing with a standard ESD control process. Pins listed as ± 1000 V may actually have higher performance.
- (2) JEDEC document JEP157 states that 250-V CDM allows safe manufacturing with a standard ESD control process. Pins listed as ± 250 V may actually have higher performance.

5.3 Recommended Operating Conditions

Typical values are specified at $V_{CC} = 3.3$ V and $T_A = 25^\circ\text{C}$ (unless otherwise noted)

		MIN	NOM	MAX	UNIT
V_{CC} Supply voltage	During program execution ⁽¹⁾ ($AV_{CC} = DV_{CC1/2} = V_{CC}$)	1.8		3.6	V
	During flash memory programming (FG461x) ($AV_{CC} = DV_{CC1/2} = V_{CC}$) ⁽¹⁾	2.7		3.6	
	During program execution, SVS enabled and PORON = 1 ⁽¹⁾ ($AV_{CC} = DV_{CC1/2} = V_{CC}$) ⁽²⁾	2		3.6	
V_{SS} Supply voltage ($AV_{SS} = DV_{SS1/2} = V_{SS}$)		0		0	V
T_A Operating free-air temperature range		-40		85	°C
$f_{(LFXT1)}$ Crystal frequency ⁽³⁾	LF selected, XTS_FLL = 0 ⁽³⁾		32.768		kHz
	XT1 selected, XTS_FLL = 1	450		8000	
	XT1 selected, XTS_FLL = 1	1000		8000	
$f_{(XT2)}$ Crystal frequency	Ceramic resonator	450		8000	kHz
	Crystal	1000		8000	
$f_{(System)}$ Processor frequency (signal MCLK)	$V_{CC} = 1.8$ V	DC		3	MHz
	$V_{CC} = 2.0$ V	DC		4.6	
	$V_{CC} = 3.6$ V	DC		8	

- (1) TI recommends powering AV_{CC} and DV_{CC} from the same source. A maximum difference of 0.3 V between AV_{CC} and DV_{CC} can be tolerated during power up and operation.
- (2) The minimum operating supply voltage is defined according to the trip point where POR is going active by decreasing the supply voltage. POR is going inactive when the supply voltage is raised above the minimum supply voltage plus the hysteresis of the SVS circuitry.
- (3) In LF mode, the LFXT1 oscillator requires a watch crystal. In XT1 mode, LFXT1 accepts a ceramic resonator or a crystal.

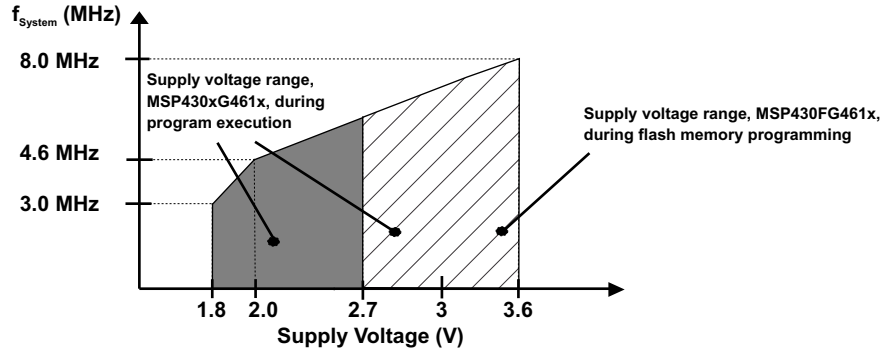

Figure 5-1. Frequency vs Supply Voltage

5.4 Supply Current Into AV_{CC} + DV_{CC} Excluding External Current

over recommended ranges of supply voltage and operating free-air temperature (unless otherwise noted)

PARAMETER		TEST CONDITION		MIN	TYP	MAX	UNIT	
I _(AM)	Active mode ^{(1) (2)} f _(MCLK) = f _(SMCLK) = 1 MHz, f _(ACLK) = 32768 Hz, XTS = 0, SELM = (0, 1), (FG461x: program executes from flash)	CG461x	T _A = -40°C to 85°C	V _{CC} = 2.2 V	280	370	μA	
				V _{CC} = 3 V	470	580		
		FG461x	T _A = -40°C to 85°C	V _{CC} = 2.2 V	400	480		
				V _{CC} = 3 V	600	740		
I _(LPM0)	Low power mode (LPM0) ^{(1) (2)}		T _A = -40°C to 85°C	V _{CC} = 2.2 V	45	70	μA	
				V _{CC} = 3 V	75	110		
I _(LPM2)	Low-power mode (LPM2), f _(MCLK) = f _(SMCLK) = 0 MHz, f _(ACLK) = 32768 Hz, SCG0 = 0 ^{(3) (2)}		T _A = -40°C to 85°C	V _{CC} = 2.2 V	11	20	μA	
				V _{CC} = 3 V	17	24		
I _(LPM3)	Low-power mode (LPM3), f _(MCLK) = f _(SMCLK) = 0 MHz, f _(ACLK) = 32768 Hz, SCG0 = 1, Basic Timer1 enabled, ACLK selected, LCD_A enabled, LCDCPEN = 0, (static mode, f _{LCD} = f _{(ACLK)/32)^{(3) (4) (2)}}		T _A = -40°C	V _{CC} = 2.2 V	1.3	4.0	μA	
					T _A = 25°C	1.3		4.0
					T _A = 60°C	2.22		6.5
					T _A = 85°C	6.5		15.0
			T _A = -40°C	V _{CC} = 3 V	1.9	5.0		
					T _A = 25°C	1.9		5.0
					T _A = 60°C	2.5		7.5
					T _A = 85°C	7.5		18.0
I _(LPM3)	Low-power mode (LPM3), f _(MCLK) = f _(SMCLK) = 0 MHz, f _(ACLK) = 32768 Hz, SCG0 = 1, Basic Timer1 enabled, ACLK selected, LCD_A enabled, LCDCPEN = 0, (4-mux mode; f _{LCD} = f _{(ACLK)/32)^{(3) (4) (2)}}		T _A = -40°C	V _{CC} = 2.2 V	1.5	5.5	μA	
					T _A = 25°C	1.5		5.5
					T _A = 60°C	2.8		7.0
					T _A = 85°C	7.2		17.0
			T _A = -40°C	V _{CC} = 3 V	2.5	6.5		
					T _A = 25°C	2.5		6.5
					T _A = 60°C	3.2		8.0
					T _A = 85°C	8.5		20.0
I _(LPM4)	Low-power mode (LPM4), f _(MCLK) = 0 MHz, f _(SMCLK) = 0 MHz, f _(ACLK) = 0 Hz, SCG0 = 1 ^{(3) (2)}		T _A = -40°C	V _{CC} = 2.2 V	0.13	1.0	μA	
					T _A = 25°C	0.22		1.0
					T _A = 60°C	0.9		2.5
					T _A = 85°C	4.3		12.5
			T _A = -40°C	V _{CC} = 3 V	0.13	1.6		
					T _A = 25°C	0.3		1.6
					T _A = 60°C	1.1		3.0
					T _A = 85°C	5.0		15.0

(1) Timer_B is clocked by f_(DCOCLK) = f_(DCO) = 1 MHz. All inputs are tied to 0 V or to V_{CC}. Outputs do not source or sink any current.

(2) Current for brownout included.

(3) All inputs are tied to 0 V or to V_{CC}. Outputs do not source or sink any current.

(4) The LPM3 currents are characterized with a Micro Crystal CC4V-T1A (9 pF) crystal and OSCCAPx = 1h.

Current consumption of active mode versus system frequency, FG version:

$$I_{(AM)} = I_{(AM)} [1 \text{ MHz}] \times f_{(\text{System})} [\text{MHz}]$$

Current consumption of active mode versus supply voltage, FG version:

$$I_{(AM)} = I_{(AM)} [3 \text{ V}] + 200 \mu\text{A/V} \times (V_{\text{CC}} - 3 \text{ V})$$

5.5 Thermal Characteristics

PARAMETER		PACKAGE	VALUE	UNIT
θ_{JA}	Junction-to-ambient thermal resistance, still air ⁽¹⁾	ZQW (S-PBGA-N113)	42	°C/W
$\theta_{JC, TOP}$	Junction-to-case (top) thermal resistance ⁽²⁾		10	°C/W
θ_{JB}	Junction-to-board thermal resistance ⁽³⁾		12	°C/W
Ψ_{JB}	Junction-to-board thermal characterization parameter		12	°C/W
Ψ_{JT}	Junction-to-top thermal characterization parameter		0.3	°C/W
θ_{JA}	Junction-to-ambient thermal resistance, still air ⁽¹⁾	PZ (S-PQFP-G100)	43.5	°C/W
$\theta_{JC, TOP}$	Junction-to-case (top) thermal resistance ⁽²⁾		6.2	°C/W
θ_{JB}	Junction-to-board thermal resistance ⁽³⁾		21.8	°C/W
Ψ_{JB}	Junction-to-board thermal characterization parameter		21.2	°C/W
Ψ_{JT}	Junction-to-top thermal characterization parameter		0.2	°C/W

- (1) The junction-to-ambient thermal resistance under natural convection is obtained in a simulation on a JEDEC-standard, High-K board, as specified in JESD51-7, in an environment described in JESD51-2a.
- (2) The junction-to-case (top) thermal resistance is obtained by simulating a cold plate test on the package top. No specific JEDEC standard test exists, but a close description can be found in the ANSI SEMI standard G30-88.
- (3) The junction-to-board thermal resistance is obtained by simulating in an environment with a ring cold plate fixture to control the PCB temperature, as described in JESD51-8.

5.6 Schmitt-Trigger Inputs – Ports P1 to P10, \overline{RST}/NMI , JTAG (TCK, TMS, TDI/TCLK, TDO/TDI)

over recommended ranges of supply voltage and operating free-air temperature (unless otherwise noted)

PARAMETER		TEST CONDITIONS	MIN	MAX	UNIT
V_{IT+}	Positive-going input threshold voltage	$V_{CC} = 2.2\text{ V}$	1.1	1.55	V
		$V_{CC} = 3\text{ V}$	1.5	1.98	
V_{IT-}	Negative-going input threshold voltage	$V_{CC} = 2.2\text{ V}$	0.4	0.9	V
		$V_{CC} = 3\text{ V}$	0.9	1.3	
V_{hys}	Input voltage hysteresis ($V_{IT+} - V_{IT-}$)	$V_{CC} = 2.2\text{ V}$	0.3	1.1	V
		$V_{CC} = 3\text{ V}$	0.5	1	

5.7 Inputs Px.x, TA_x, TB_x

over recommended ranges of supply voltage and operating free-air temperature (unless otherwise noted)

PARAMETER		TEST CONDITIONS	V_{CC}	MIN	MAX	UNIT
$t_{(int)}$	External interrupt timing	Port P1, P2: P1.x to P2.x, external trigger signal for the interrupt flag ⁽¹⁾	2.2 V	62	ns	
			3 V	50		
$t_{(cap)}$	Timer_A, Timer_B capture timing	TA0, TA1, TA2 TB0, TB1, TB2, TB3, TB4, TB5, TB6	2.2 V	62	ns	
			3 V	50		
$f_{(TAext)}$	Timer_A or Timer_B clock frequency externally applied to pin	TACLK, TBCLK INCLK $t_{(H)} = t_{(L)}$	2.2 V	8	MHz	
$f_{(TBext)}$			3 V	10		
$f_{(TAint)}$	Timer A or Timer B clock frequency	SMCLK or ACLK signal selected	2.2 V	8	MHz	
$f_{(TBint)}$			3 V	10		

(1) The external signal sets the interrupt flag every time the minimum $t_{(int)}$ parameters are met. It may be set even with trigger signals shorter than $t_{(int)}$.

5.8 Leakage Current – Ports P1 to P10⁽¹⁾

over recommended ranges of supply voltage and operating free-air temperature (unless otherwise noted)

PARAMETER		TEST CONDITIONS	MIN	MAX	UNIT
$I_{lkg}(Px.y)$	Leakage current, Port Px	$V(Px.y)$ ⁽²⁾ ($1 \leq x \leq 10, 0 \leq y \leq 7$)	$V_{CC} = 2.2\text{ V}, 3\text{ V}$	± 50	nA

(1) The leakage current is measured with V_{SS} or V_{CC} applied to the corresponding pins, unless otherwise noted.

(2) The port pin must be selected as input.

5.9 Outputs – Ports P1 to P10

over recommended ranges of supply voltage and operating free-air temperature (unless otherwise noted)

PARAMETER		TEST CONDITIONS	MIN	MAX	UNIT
V_{OH}	High-level output voltage	$I_{OH(max)} = -1.5\text{ mA}, V_{CC} = 2.2\text{ V}$ ⁽¹⁾	$V_{CC} - 0.25$	V_{CC}	V
		$I_{OH(max)} = -6\text{ mA}, V_{CC} = 2.2\text{ V}$ ⁽²⁾	$V_{CC} - 0.6$	V_{CC}	
		$I_{OH(max)} = -1.5\text{ mA}, V_{CC} = 3\text{ V}$ ⁽¹⁾	$V_{CC} - 0.25$	V_{CC}	
		$I_{OH(max)} = -6\text{ mA}, V_{CC} = 3\text{ V}$ ⁽²⁾	$V_{CC} - 0.6$	V_{CC}	
V_{OL}	Low-level output voltage	$I_{OL(max)} = 1.5\text{ mA}, V_{CC} = 2.2\text{ V}$ ⁽¹⁾	V_{SS}	$V_{SS} + 0.25$	V
		$I_{OL(max)} = 6\text{ mA}, V_{CC} = 2.2\text{ V}$ ⁽²⁾	V_{SS}	$V_{SS} + 0.6$	
		$I_{OL(max)} = 1.5\text{ mA}, V_{CC} = 3\text{ V}$ ⁽¹⁾	V_{SS}	$V_{SS} + 0.25$	
		$I_{OL(max)} = 6\text{ mA}, V_{CC} = 3\text{ V}$ ⁽²⁾	V_{SS}	$V_{SS} + 0.6$	

(1) The maximum total current, $I_{OH(max)}$ and $I_{OL(max)}$, for all outputs combined, should not exceed $\pm 12\text{ mA}$ to satisfy the maximum specified voltage drop.

(2) The maximum total current, $I_{OH(max)}$ and $I_{OL(max)}$, for all outputs combined, should not exceed $\pm 48\text{ mA}$ to satisfy the maximum specified voltage drop.

5.10 Output Frequency

over recommended ranges of supply voltage and operating free-air temperature (unless otherwise noted)

PARAMETER		TEST CONDITIONS	MIN	TYP	MAX	UNIT	
$f_{(P_{x,y})}$	$(1 \leq x \leq 10, 0 \leq y \leq 7)$	$C_L = 20 \text{ F}, I_L = \pm 1.5 \text{ mA}$	$V_{CC} = 2.2 \text{ V}$	DC		10	MHz
			$V_{CC} = 3 \text{ V}$	DC		12	
$f_{(MCLK)}$	P1.1/TA0/MCLK	$C_L = 20 \text{ pF}$	$V_{CC} = 2.2 \text{ V}$			10	MHz
$f_{(SMCLK)}$	P1.4/TBCLK/SMCLK						
$f_{(ACLK)}$	P1.5/TACLK/ACLK			$V_{CC} = 3 \text{ V}$	DC		
$t_{(Xdc)}$	Duty cycle of output frequency	P1.5/TACLK/ACLK, $C_L = 20 \text{ pF}, V_{CC} = 2.2 \text{ V}, 3 \text{ V}$	$f_{(ACLK)} = f_{(LFXT1)} = f_{(XT1)}$	40%		60%	
			$f_{(ACLK)} = f_{(LFXT1)} = f_{(LF)}$	30%		70%	
			$f_{(ACLK)} = f_{(LFXT1)}$		50%		
		P1.1/TA0/MCLK, $C_L = 20 \text{ pF}, V_{CC} = 2.2 \text{ V}, 3 \text{ V}$	$f_{(MCLK)} = f_{(XT1)}$	40%		60%	
			$f_{(MCLK)} = f_{(DCOCLK)}$	50% – 15 ns	50%	50%+ 15 ns	
		P1.4/TBCLK/SMCLK, $C_L = 20 \text{ pF}, V_{CC} = 2.2 \text{ V}, 3 \text{ V}$	$f_{(SMCLK)} = f_{(XT2)}$	40%		60%	
$f_{(SMCLK)} = f_{(DCOCLK)}$	50% – 15 ns		50%	50% + 15 ns			

5.11 Typical Characteristics – Outputs

over recommended ranges of supply voltage and operating free-air temperature (unless otherwise noted)

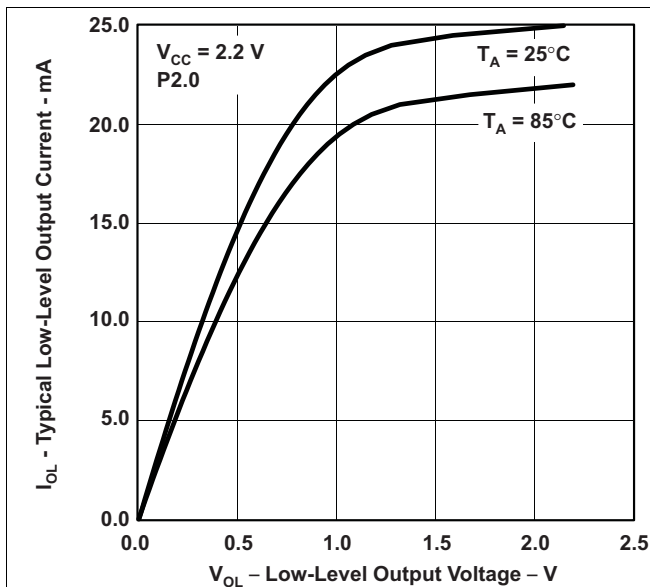

Figure 5-2. Typical Low-Level Output Current vs Typical Low-Level Output Current

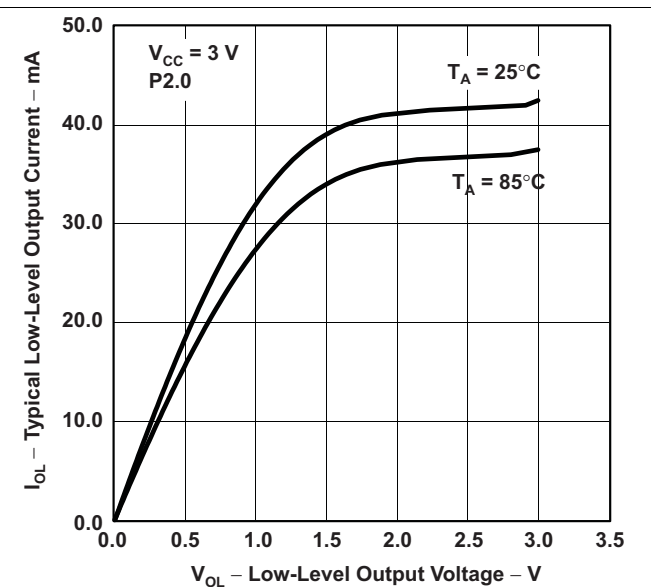

Figure 5-3. Typical Low-Level Output Current vs Typical Low-Level Output Current

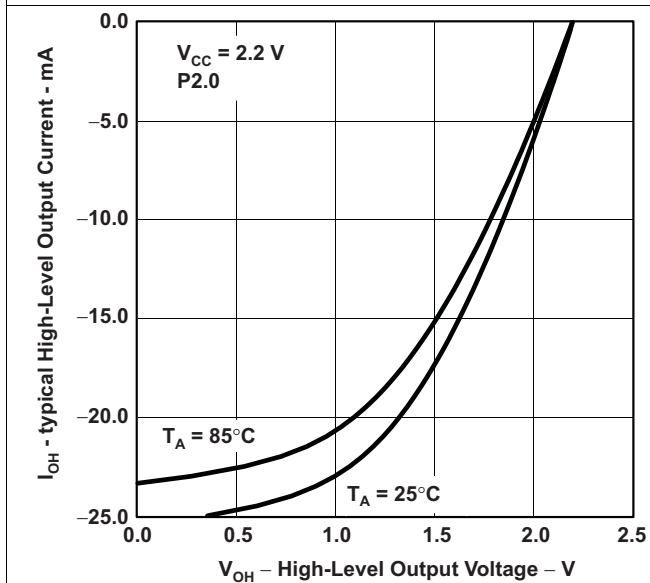

Figure 5-4. Typical High-Level Output Current vs Typical High-Level Output Current

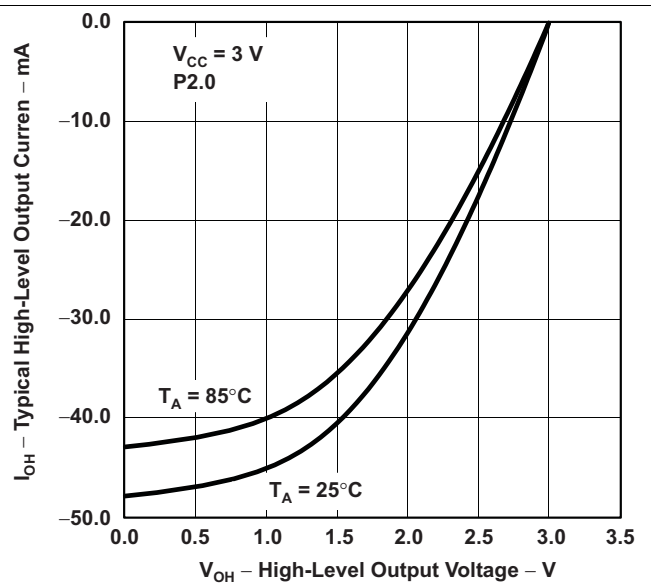

Figure 5-5. Typical High-Level Output Current vs Typical High-Level Output Current

5.12 Wake-up Timing From LPM3

over recommended ranges of supply voltage and operating free-air temperature (unless otherwise noted)

PARAMETER		TEST CONDITIONS		MIN	MAX	UNIT
$t_{d(LPM3)}$	Delay time	$f = 1$ MHz	$V_{CC} = 2.2$ V, 3 V		6	μ s
		$f = 2$ MHz		6		
		$f = 3$ MHz		6		

5.13 RAM

over recommended ranges of supply voltage and operating free-air temperature (unless otherwise noted)

PARAMETER	TEST CONDITIONS	MIN	MAX	UNIT
VRAMh	CPU halted ⁽¹⁾	1.6		V

(1) This parameter defines the minimum supply voltage when the data in program memory RAM remain unchanged. No program execution should take place during this supply voltage condition.

5.14 LCD_A

over recommended ranges of supply voltage and operating free-air temperature (unless otherwise noted)

PARAMETER		TEST CONDITIONS	V_{CC}	MIN	TYP	MAX	UNIT
$V_{CC(LCD)}$	Supply voltage ⁽¹⁾	Charge pump enabled (LCDCPEN = 1, VLCDx > 0000)		2.2		3.6	V
$I_{CC(LCD)}$	Supply current ⁽¹⁾	$V_{LCD(typ)} = 3$ V, LCDCPEN = 1, VLCDx = 1000, all segments on, $f_{LCD} = f_{ACLK}/32$, no LCD connected ⁽²⁾ , $T_A = 25^\circ$ C	2.2 V		3		μ A
C_{LCD}	Capacitor on LCDCAP ⁽³⁾ (4)	Charge pump enabled (LCDCPEN = 1, VLCDx > 0000)		4.7			μ F
f_{LCD}	LCD frequency					1.1	kHz
V_{LCD}	LCD voltage ⁽⁴⁾	VLCDx = 0000	2.2 V		V_{CC}		V
		VLCDx = 0001		2.60			
		VLCDx = 0010		2.66			
		VLCDx = 0011		2.72			
		VLCDx = 0100		2.78			
		VLCDx = 0101		2.84			
		VLCDx = 0110		2.90			
		VLCDx = 0111		2.96			
		VLCDx = 1000		3.02			
		VLCDx = 1001		3.08			
		VLCDx = 1010		3.14			
		VLCDx = 1011		3.20			
		VLCDx = 1100		3.26			
		VLCDx = 1101		3.32			
VLCDx = 1110	3.38						
VLCDx = 1111	3.44	3.60					
R_{LCD}	LCD driver output impedance	$V_{LCD} = 3$ V, CPEN = 1, VLCDx = 1000, $I_{LOAD} = \pm 10$ μ A	2.2 V			10	k Ω

(1) Refer to the supply current specifications $I_{(LPM3)}$ for additional current specifications with the LCD_A module active.

(2) Connecting an actual display increases the current consumption depending on the size of the LCD.

(3) Enabling the internal charge pump with an external capacitor smaller than the minimum specified might damage the device.

(4) Segments S0 through S3 are disabled when the LCD charge pump feature is enabled (LCDCPEN = 1) and, therefore, cannot be used together with the LCD charge pump. On the MSP430xG461x devices only, S0 through S3 are also disabled if VLCDxEXT = 1. This setting is typically used to apply an external LCD voltage supply to the LCDCAP terminal. For these devices, set LCDCPEN = 0, VLCDxEXT = 0, and VLCDx > 0 to enable an external LCD voltage supply to be applied to the LCDCAP terminal.

5.15 Comparator_A⁽¹⁾

over recommended ranges of supply voltage and operating free-air temperature (unless otherwise noted)

PARAMETER		TEST CONDITIONS	V _{CC}	MIN	TYP	MAX	UNIT
I _(CC)		CAON = 1, CARSEL = 0, CAREF = 0	2.2 V		25	40	μA
			3 V		45	60	
I _(Refladder/RefDiode)		CAON = 1, CARSEL = 0, CAREF = (1, 2, 3), No load at P1.6/CA0 and P1.7/CA1	2.2 V		30	50	μA
			3 V		45	71	
V _(Ref025)	Voltage @ 0.25 V _{CC} node V _{CC}	PCA0 = 1, CARSEL = 1, CAREF = 1, No load at P1.6/CA0 and P1.7/CA1	2.2 V, 3 V	0.23	0.24	0.25	
V _(Ref050)	Voltage @ 0.5 V _{CC} node V _{CC}	PCA0 = 1, CARSEL = 1, CAREF = 2, No load at P1.6/CA0 and P1.7/CA1	2.2 V, 3 V	0.47	0.48	0.5	
V _(RefVT)		PCA0 = 1, CARSEL = 1, CAREF = 3, No load at P1.6/CA0 and P1.7/CA1, T _A = 85°C	2.2 V	390	480	540	mV
			3 V	400	490	550	
V _{IC}	Common-mode input voltage range	CAON = 1	2.2 V, 3 V	0		V _{CC} – 1	V
V _p – V _s	Offset voltage ⁽²⁾		2.2 V, 3 V	–30		30	mV
V _{hys}	Input hysteresis	CAON = 1	2.2 V, 3 V	0	0.7	1.4	mV
t _(response LH)		T _A = 25°C, Overdrive 10 mV, without filter: CAF = 0	2.2 V	160	210	300	ns
			3 V	80	150	240	
		T _A = 25°C, Overdrive 10 mV, without filter: CAF = 1	2.2 V	1.4	1.9	3.4	μs
			3 V	0.9	1.5	2.6	
t _(response HL)		T _A = 25°C, Overdrive 10 mV, without filter: CAF = 0	2.2 V	130	210	300	ns
			3 V	80	150	240	
		T _A = 25°C, Overdrive 10 mV, without filter: CAF = 1	2.2 V	1.4	1.9	3.4	μs
			3 V	0.9	1.5	2.6	

(1) The leakage current for the Comparator_A terminals is identical to I_{(kg(Px.x))} specification.

(2) The input offset voltage can be cancelled by using the CAEX bit to invert the Comparator_A inputs on successive measurements. The two successive measurements are then summed together.

5.16 Typical Characteristics – Comparator_A

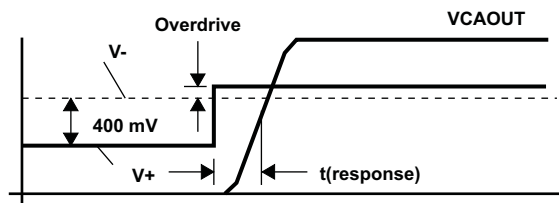
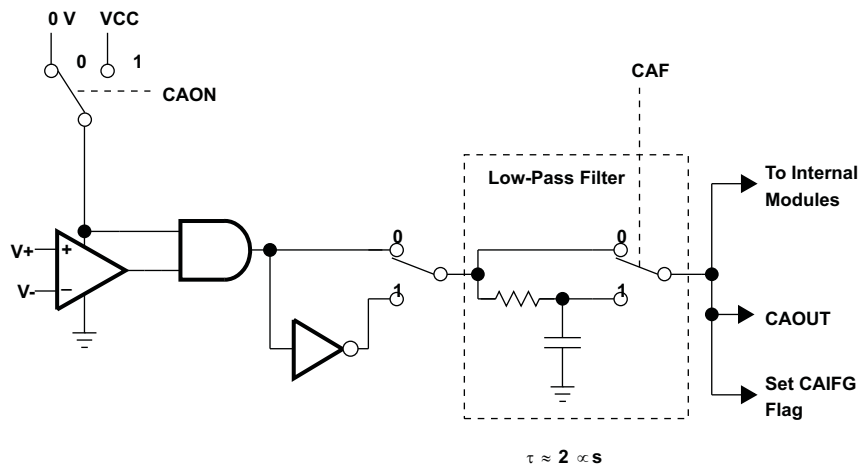
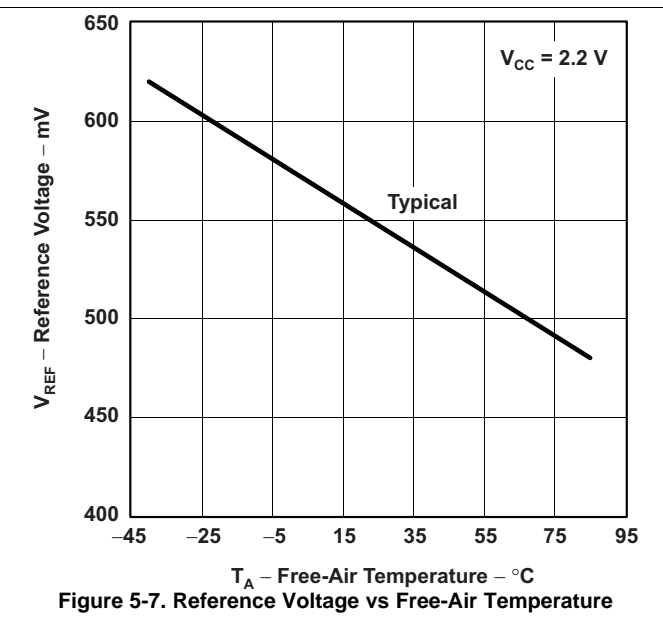
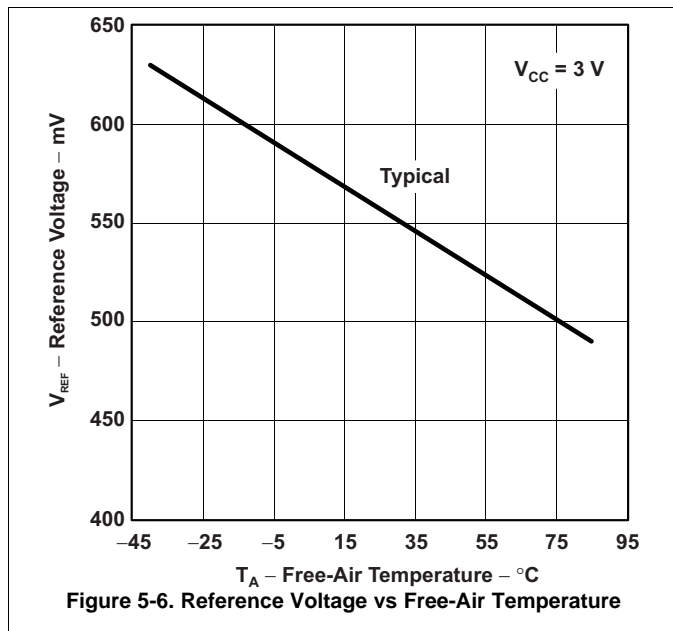

5.17 POR, BOR

over recommended ranges of supply voltage and operating free-air temperature (unless otherwise noted)⁽¹⁾

PARAMETER	TEST CONDITIONS	MIN	TYP	MAX	UNIT
$t_{d(BOR)}$				2000	μs
$V_{CC(start)}$	$dV_{CC}/dt \leq 3 \text{ V/s}$ (see Figure 5-10)		$0.7 \times V_{(B_IT-)}$		V
$V_{(B_IT-)}$	$dV_{CC}/dt \leq 3 \text{ V/s}$ (see Figure 5-10 through Figure 5-12)			1.79	V
$V_{hys(B_IT-)}$	$dV_{CC}/dt \leq 3 \text{ V/s}$ (see Figure 5-10)	70	130	210	mV
$t_{(reset)}$	Pulse duration needed at RST/NMI pin to accepted reset internally, $V_{CC} = 2.2 \text{ V}, 3 \text{ V}$	2			μs

(1) The current consumption of the brownout module is already included in the I_{CC} current consumption data.

(2) The voltage level $V_{(B_IT-)} + V_{hys(B_IT-)} \leq 1.89 \text{ V}$.

(3) During power up, the CPU begins code execution following a period of $t_{d(BOR)}$ after $V_{CC} = V_{(B_IT-)} + V_{hys(B_IT-)}$. The default FLL+ settings must not be changed until $V_{CC} \geq V_{CC(min)}$, where $V_{CC(min)}$ is the minimum supply voltage for the desired operating frequency. See the MSP430x4xx Family User's Guide (SLAU056) for more information on the brownout and SVS circuit.

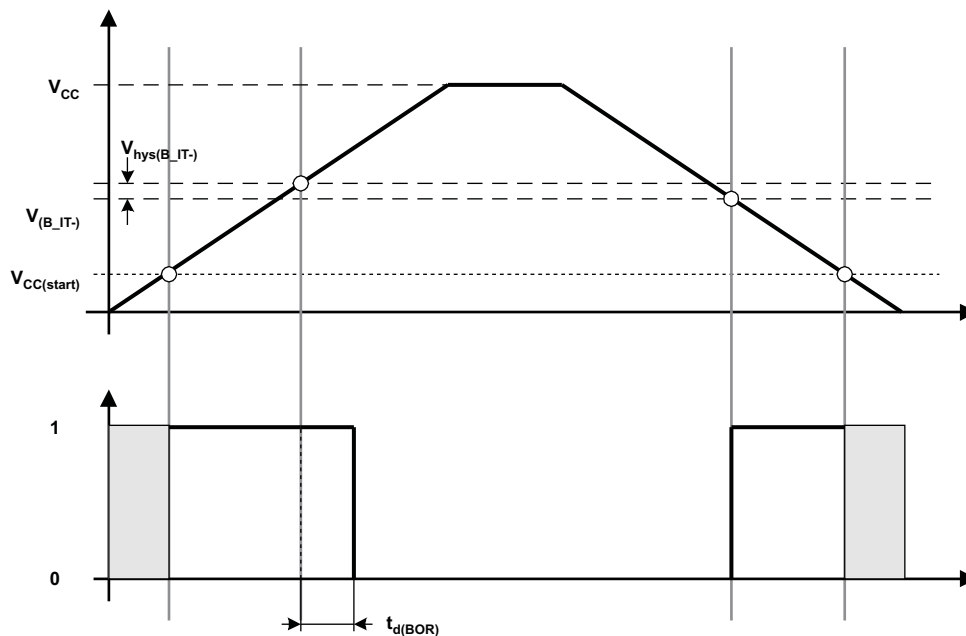

Figure 5-10. POR, BOR vs Supply Voltage

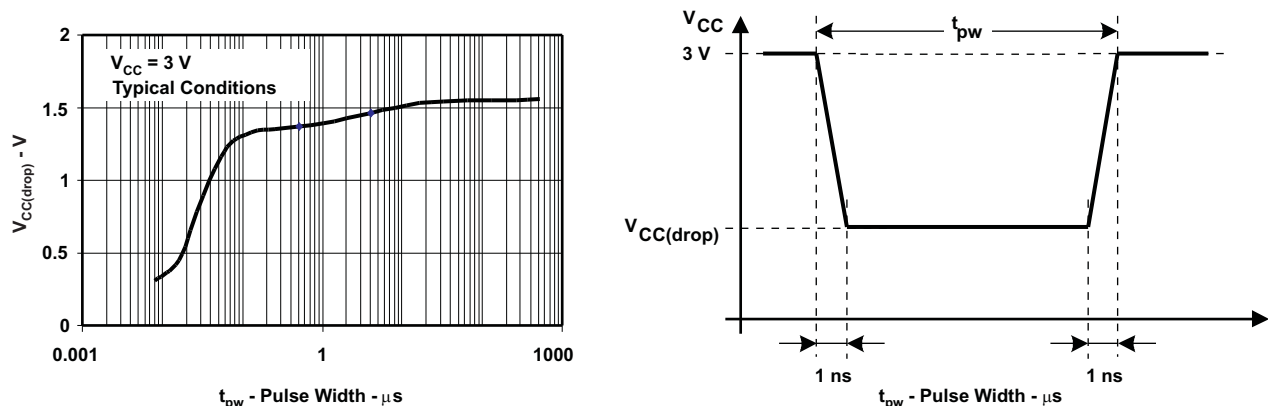

Figure 5-11. $V_{CC(drop)}$ Level with a Square Voltage Drop to Generate a POR or BOR Signal

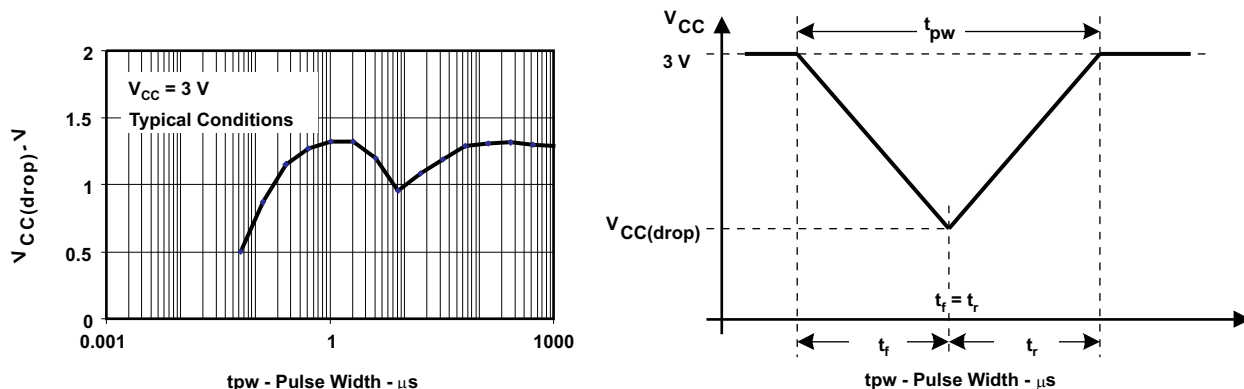

Figure 5-12. $V_{CC(drop)}$ Level With a Triangle Voltage Drop to Generate a POR or BOR Signal

5.18 SVS (Supply Voltage Supervisor and Monitor)

over recommended ranges of supply voltage and operating free-air temperature (unless otherwise noted)

PARAMETER	TEST CONDITIONS		MIN	TYP	MAX	UNIT
$t_{(SVSR)}$	$dV_{CC}/dt > 30 \text{ V/ms}$ (see Figure 5-13)		5		150	μs
	$dV_{CC}/dt \leq 30 \text{ V/ms}$				2000	
$t_{d(SV\text{Son})}$	SVS on, switch from VLD = 0 to VLD \neq 0, $V_{CC} = 3 \text{ V}$			150	300	μs
t_{settle}	VLD \neq 0 ⁽¹⁾				12	μs
$V_{(SV\text{Sstart})}$	VLD \neq 0, $V_{CC}/dt \leq 3 \text{ V/s}$ (see Figure 5-13)			1.55	1.7	V
$V_{\text{hys}(SV\text{S_IT-})}$	$V_{CC}/dt \leq 3 \text{ V/s}$ (see Figure 5-13)	VLD = 1	70	120	155	mV
		VLD = 2 to 14	$V_{(SV\text{S_IT-})} \times 0.001$		$V_{(SV\text{S_IT-})} \times 0.016$	
	$V_{CC}/dt \leq 3 \text{ V/s}$ (see Figure 5-13), external voltage applied on A7	VLD = 15	4.4		20	mV
$V_{(SV\text{S_IT-})}$	$V_{CC}/dt \leq 3 \text{ V/s}$ (see Figure 5-13)	VLD = 1	1.8	1.9	2.05	V
		VLD = 2	1.94	2.1	2.23	
		VLD = 3	2.05	2.2	2.35	
		VLD = 4	2.14	2.3	2.46	
		VLD = 5	2.24	2.4	2.58	
		VLD = 6	2.33	2.5	2.69	
		VLD = 7	2.46	2.65	2.84	
		VLD = 8	2.58	2.8	2.97	
		VLD = 9	2.69	2.9	3.10	
		VLD = 10	2.83	3.05	3.26	
		VLD = 11	2.94	3.2	3.39	
		VLD = 12	3.11	3.35	3.58 ⁽²⁾	
		VLD = 13	3.24	3.5	3.73 ⁽²⁾	
		VLD = 14	3.43	3.7 ⁽²⁾	3.96 ⁽²⁾	
	$V_{CC}/dt \leq 3 \text{ V/s}$ (see Figure 5-13), external voltage applied on A7	VLD = 15	1.1	1.2	1.3	
$I_{CC(SVS)}$ ⁽³⁾	VLD \neq 0, $V_{CC} = 2.2 \text{ V}, 3 \text{ V}$			10	15	μA

- (1) t_{settle} is the settling time that the comparator output needs to have a stable level after VLD is switched from VLD \neq 0 to a different VLD value from 2 to 15. The overdrive is assumed to be $> 50 \text{ mV}$.
- (2) The recommended operating voltage range is limited to 3.6 V.
- (3) The current consumption of the SVS module is not included in the I_{CC} current consumption data.

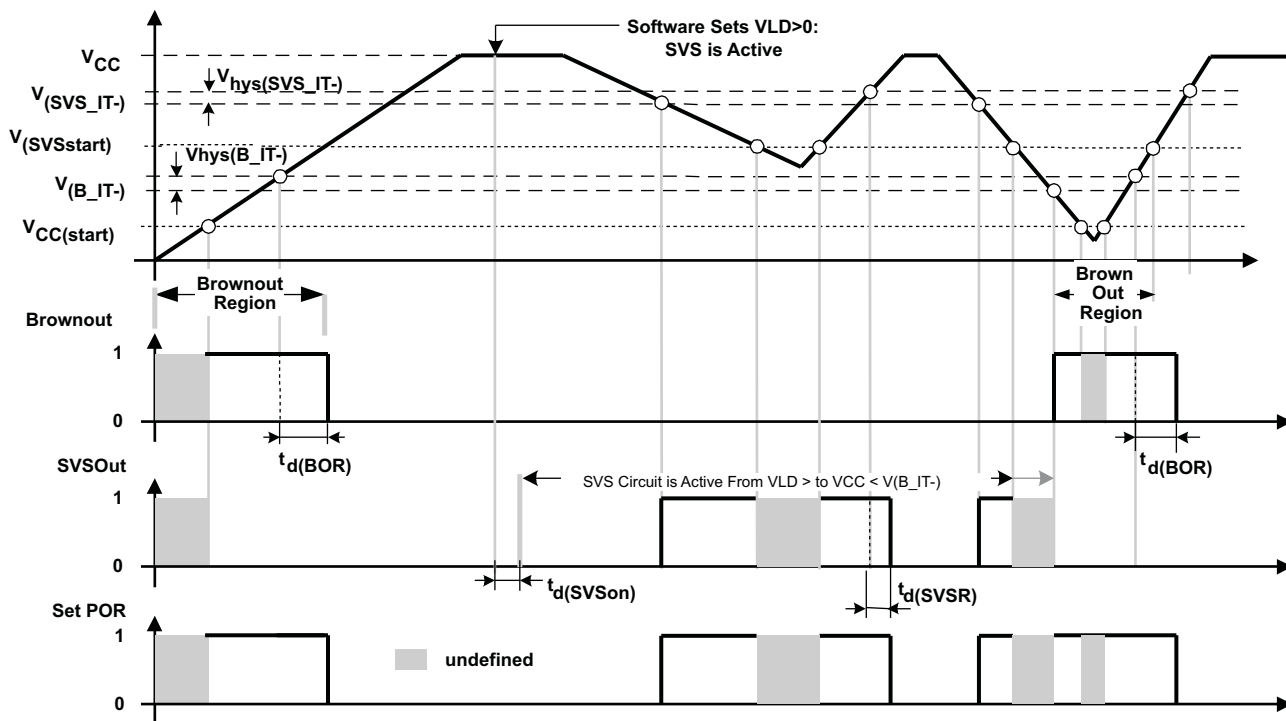

Figure 5-13. SVS Reset (SVSR) vs Supply Voltage

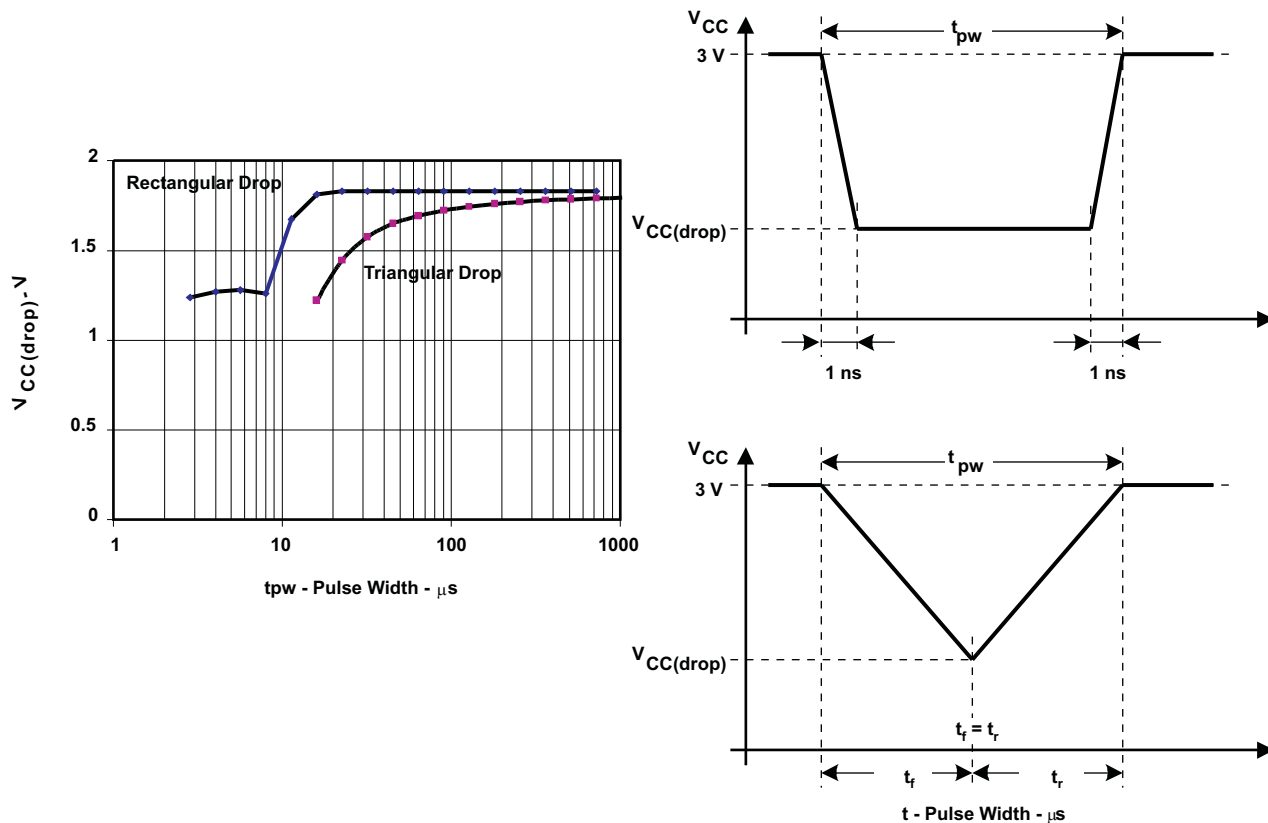

Figure 5-14. $V_{CC(drop)}$ with a Square Voltage Drop and a Triangle Voltage Drop to Generate an SVS Signal

5.19 DCO

over recommended ranges of supply voltage and operating free-air temperature (unless otherwise noted)

PARAMETER	TEST CONDITIONS	V _{CC}	MIN	TYP	MAX	UNIT
f _(DCOCLK)	N _(DCO) = 01Eh, FN ₈ = FN ₄ = FN ₃ = FN ₂ = 0, D = 2, DCOPLUS = 0	2.2 V, 3 V		1		MHz
f _(DCO = 2)	FN ₈ = FN ₄ = FN ₃ = FN ₂ = 0, DCOPLUS = 1	2.2 V	0.3	0.65	1.25	MHz
		3 V	0.3	0.7	1.3	
f _(DCO = 27)	FN ₈ = FN ₄ = FN ₃ = FN ₂ = 0, DCOPLUS = 1	2.2 V	2.5	5.6	10.5	MHz
		3 V	2.7	6.1	11.3	
f _(DCO = 2)	FN ₈ = FN ₄ = FN ₃ = FN ₂ = 1, DCOPLUS = 1	2.2 V	0.7	1.3	2.3	MHz
		3 V	0.8	1.5	2.5	
f _(DCO = 27)	FN ₈ = FN ₄ = FN ₃ = FN ₂ = 1, DCOPLUS = 1	2.2 V	5.7	10.8	18	MHz
		3 V	6.5	12.1	20	
f _(DCO = 2)	FN ₈ = FN ₄ = 0, FN ₃ = 1, FN ₂ = x, DCOPLUS = 1	2.2 V	1.2	2	3	MHz
		3 V	1.3	2.2	3.5	
f _(DCO = 27)	FN ₈ = FN ₄ = 0, FN ₃ = 1, FN ₂ = x, DCOPLUS = 1	2.2 V	9	15.5	25	MHz
		3 V	10.3	17.9	28.5	
f _(DCO = 2)	FN ₈ = 0, FN ₄ = 1, FN ₃ = FN ₂ = x, DCOPLUS = 1	2.2 V	1.8	2.8	4.2	MHz
		3 V	2.1	3.4	5.2	
f _(DCO = 27)	FN ₈ = 0, FN ₄ = 1, FN ₃ = FN ₂ = x, DCOPLUS = 1	2.2 V	13.5	21.5	33	MHz
		3 V	16	26.6	41	
f _(DCO = 2)	FN ₈ = 1, FN ₄ = 1 = FN ₃ = FN ₂ = x, DCOPLUS = 1	2.2 V	2.8	4.2	6.2	MHz
		3 V	4.2	6.3	9.2	
f _(DCO = 27)	FN ₈ = 1, FN ₄ = 1 = FN ₃ = FN ₂ = x, DCOPLUS = 1	2.2 V	21	32	46	MHz
		3 V	30	46	70	
S _n	Step size between adjacent DCO taps: S _n = f _{(DCO(Tap n+1))} / f _{(DCO(Tap n))} (see Figure 5-16 for taps 21 to 27)	1 < TAP ≤ 20	1.06		1.11	
		TAP = 27	1.07		1.17	
D _t	Temperature drift, N _(DCO) = 01Eh, FN ₈ = FN ₄ = FN ₃ = FN ₂ = 0, D = 2, DCOPLUS = 0	2.2 V	-0.2	-0.3	-0.4	%°C
		3 V	-0.2	-0.3	-0.4	
D _V	Drift with V _{CC} variation, N _(DCO) = 01Eh, FN ₈ = FN ₄ = FN ₃ = FN ₂ = 0, D = 2, DCOPLUS = 0		0	5	15	%/V

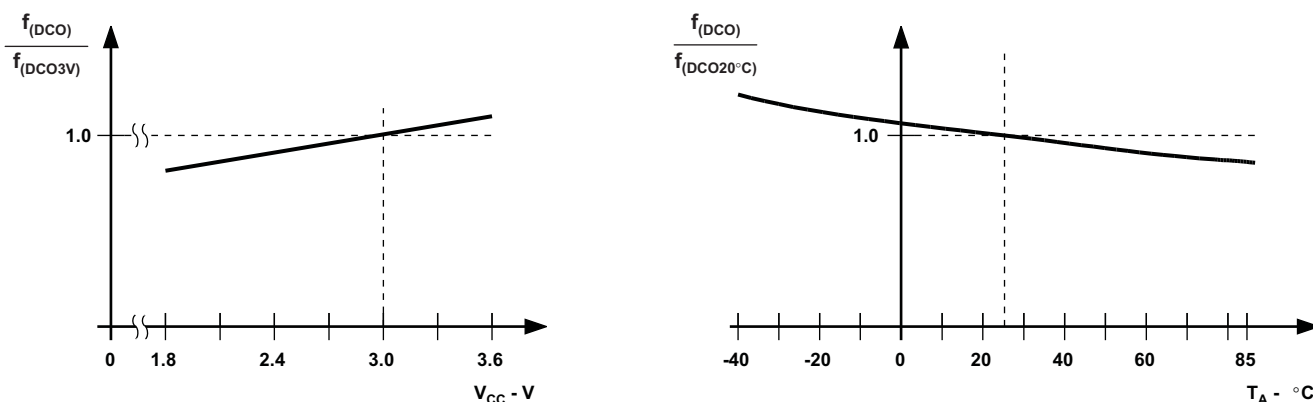

Figure 5-15. DCO Frequency vs Supply Voltage V_{CC} and vs Ambient Temperature

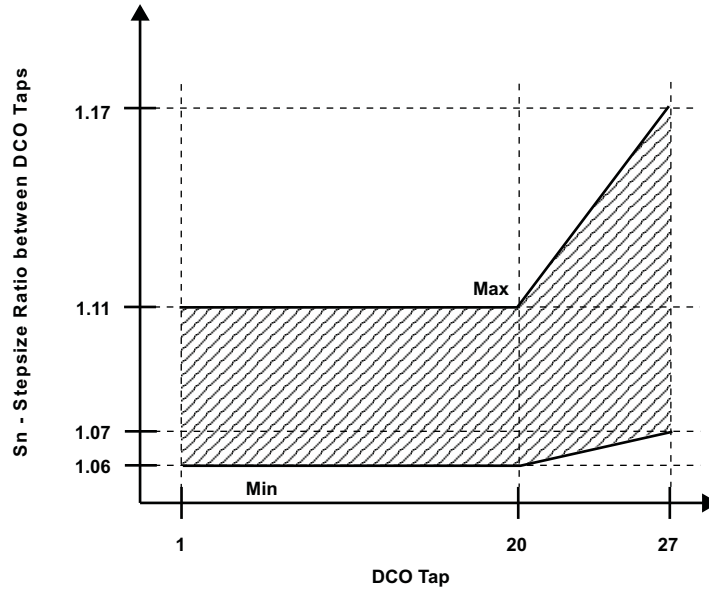

Figure 5-16. DCO Tap Step Size

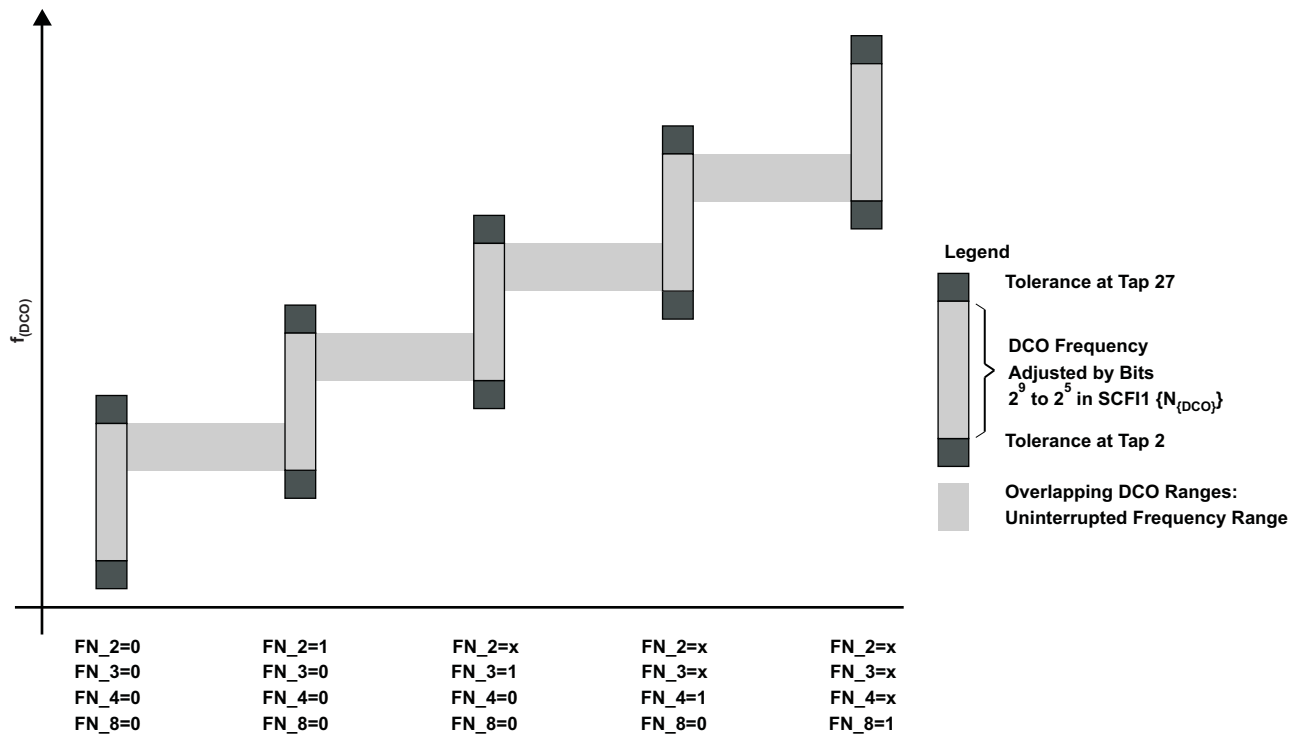

Figure 5-17. Five Overlapping DCO Ranges Controlled by FN_x Bits

5.20 Crystal Oscillator, LFXT1 Oscillator

over recommended ranges of supply voltage and operating free-air temperature (unless otherwise noted)^{(1) (2)}

PARAMETER		TEST CONDITIONS	MIN	TYP	MAX	UNIT
C _{XIN}	Integrated input capacitance ⁽³⁾	OSCCAPx = 0h, V _{CC} = 2.2 V, 3 V		0		pF
		OSCCAPx = 1h, V _{CC} = 2.2 V, 3 V		10		
		OSCCAPx = 2h, V _{CC} = 2.2 V, 3 V		14		
		OSCCAPx = 3h, V _{CC} = 2.2 V, 3 V		18		
C _{XOUT}	Integrated output capacitance ⁽³⁾	OSCCAPx = 0h, V _{CC} = 2.2 V, 3 V		0		pF
		OSCCAPx = 1h, V _{CC} = 2.2 V, 3 V		10		
		OSCCAPx = 2h, V _{CC} = 2.2 V, 3 V		14		
		OSCCAPx = 3h, V _{CC} = 2.2 V, 3 V		18		
V _{IL}	Low-level input voltage at XIN	V _{CC} = 2.2 V, 3 V ⁽⁴⁾	V _{SS}		0.2 × V _{CC}	V
V _{IH}	High-level input voltage at XIN	V _{CC} = 2.2 V, 3 V ⁽⁴⁾	0.8 × V _{CC}		V _{CC}	V

- (1) The parasitic capacitance from the package and board may be estimated to be 2 pF. The effective load capacitor for the crystal is $(C_{XIN} \times C_{XOUT}) / (C_{XIN} + C_{XOUT})$. This is independent of XTS_FLL.
- (2) To improve EMI on the low-power LFXT1 oscillator, particularly in the LF mode (32 kHz), the following guidelines should be observed.
- Keep the trace between the MCU and the crystal as short as possible.
 - Design a good ground plane around the oscillator pins.
 - Prevent crosstalk from other clock or data lines into oscillator pins XIN and XOUT.
 - Avoid running PCB traces underneath or adjacent to the XIN and XOUT pins.
 - Use assembly materials and processes that avoid any parasitic load on the oscillator XIN and XOUT pins.
 - If conformal coating is used, ensure that it does not induce capacitive or resistive leakage between the oscillator pins.
 - Do not route the XOUT line to the JTAG header to support the serial programming adapter as shown in other documentation. This signal is no longer required for the serial programming adapter.
- (3) TI recommends external capacitance for precision real-time clock applications; OSCCAPx = 0h.
- (4) Applies only when using an external logic-level clock source. XTS_FLL must be set. Not applicable when using a crystal or resonator.

5.21 Crystal Oscillator, XT2 Oscillator

over recommended ranges of supply voltage and operating free-air temperature (unless otherwise noted)⁽¹⁾

PARAMETER		TEST CONDITIONS	MIN	TYP	MAX	UNIT
C _{XT2IN}	Integrated input capacitance	V _{CC} = 2.2 V, 3 V		2		pF
C _{XT2OUT}	Integrated output capacitance	V _{CC} = 2.2 V, 3 V		2		pF
V _{IL}	Input levels at XT2IN		V _{SS}		0.2 × V _{CC}	V
V _{IH}		V _{CC} = 2.2 V, 3 V ⁽²⁾	0.8 × V _{CC}		V _{CC}	V

- (1) The oscillator needs capacitors at both terminals, with values specified by the crystal manufacturer.
- (2) Applies only when using an external logic-level clock source. Not applicable when using a crystal or resonator.

5.22 USCI (UART Mode)

over recommended ranges of supply voltage and operating free-air temperature (unless otherwise noted)

PARAMETER		TEST CONDITIONS	V _{CC}	MIN	TYP	MAX	UNIT
f _{USCI}	USCI input clock frequency	Internal: SMCLK, ACLK External: UCLK Duty cycle = 50% ±10%				f _{SYSTEM}	MHz
f _{BITCLK}	BITCLK clock frequency (equals baud rate in Mbaud)		2.2 V, 3 V			1	MHz
t _r	UART receive deglitch time UART ⁽¹⁾		2.2 V	50	150	600	ns
			3 V	50	100	600	

- (1) Pulses on the UART receive input (UCxRX) shorter than the UART receive deglitch time are suppressed. To ensure that pulses are correctly recognized, their duration should exceed the maximum specification of the deglitch time.

5.23 USCI (SPI Master Mode)

over recommended ranges of supply voltage and operating free-air temperature (unless otherwise noted) (see [Figure 5-18](#) and [Figure 5-19](#))

PARAMETER		TEST CONDITIONS	V _{CC}	MIN	MAX	UNIT
f _{USCI}	USCI input clock frequency	SMCLK, ACLK Duty cycle = 50% ±10%		f _{SYSTEM}		MHz
t _{SU,MI}	SOMI input data setup time		2.2 V	110		ns
			3 V	75		
t _{HD,MI}	iSOMI input data hold time		2.2 V	0		ns
			3 V	0		
t _{VALID,MO}	SIMO output data valid time	UCLK edge to SIMO valid, C _L = 20 pF	2.2 V		30	ns
			3 V		20	

5.24 USCI (SPI Slave Mode)

over recommended ranges of supply voltage and operating free-air temperature (unless otherwise noted) (see [Figure 5-20](#) and [Figure 5-21](#))

PARAMETER		TEST CONDITIONS	V _{CC}	MIN	TYP	MAX	UNIT
t _{STE,LEAD}	STE lead time STE low to clock		2.2 V, 3 V	50			ns
t _{STE,LAG}	STE lag time Last clock to STE high		2.2 V, 3 V	10			ns
t _{STE,ACC}	STE access time STE low to SOMI data out		2.2 V, 3 V	50			ns
t _{STE,DIS}	STE disable time STE high to SOMI high impedance		2.2 V, 3 V	50			ns
t _{SU,SI}	SIMO input data setup time		2.2 V	20			ns
			3 V	15			
t _{HD,SI}	SIMO input data hold time		2.2 V	10			ns
			3 V	10			
t _{VALID,SO}	SOMI output data valid time	UCLK edge to SOMI valid, C _L = 20 pF	2.2 V	75	110		ns
			3 V	50	75		

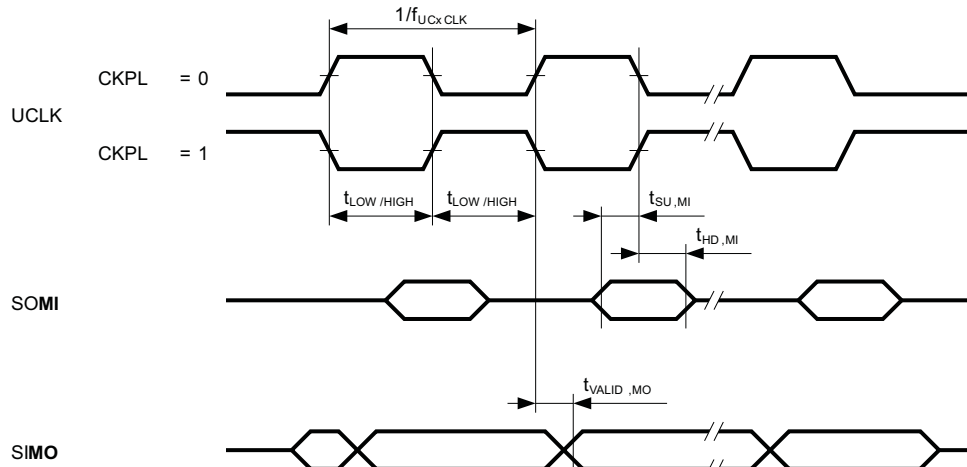

Figure 5-18. SPI Master Mode, CKPH = 0

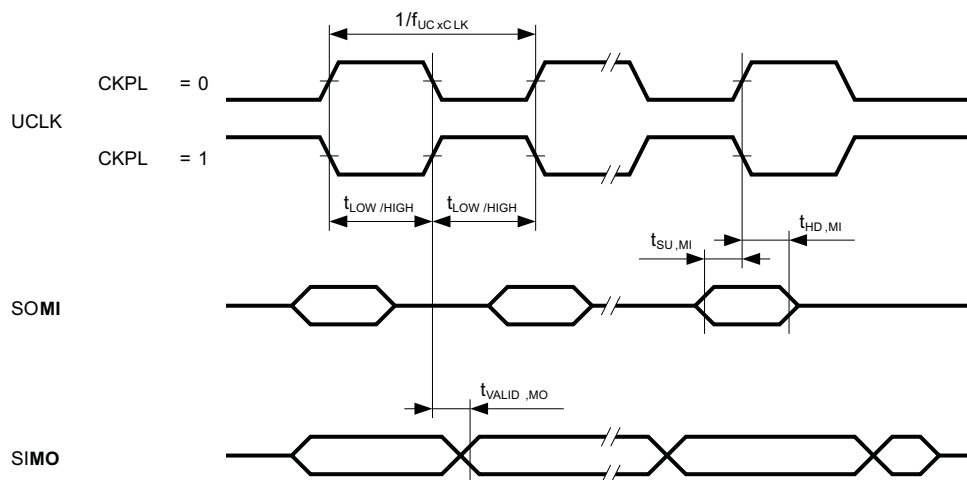

Figure 5-19. SPI Master Mode, CKPH = 1

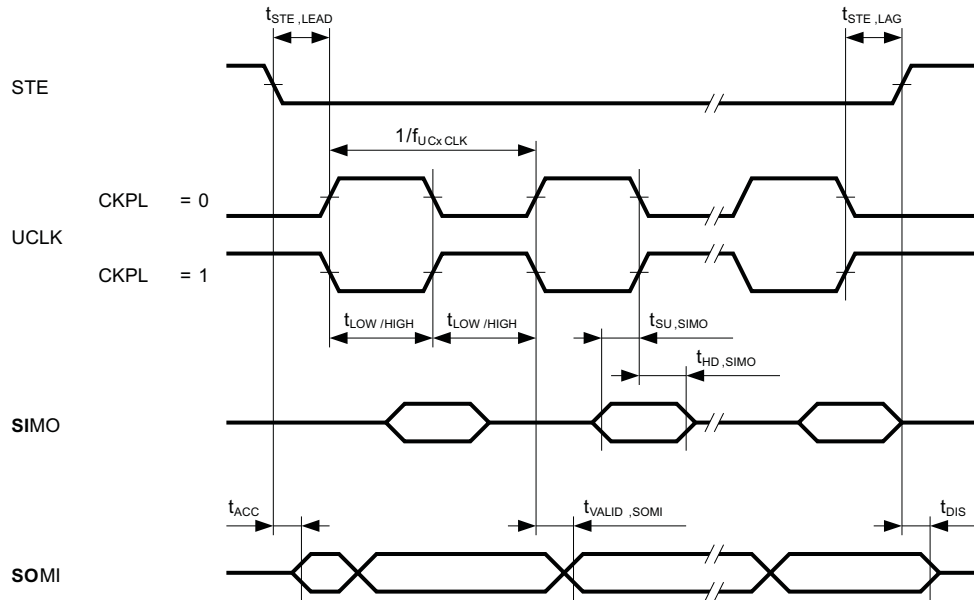

Figure 5-20. SPI Slave Mode, CKPH = 0

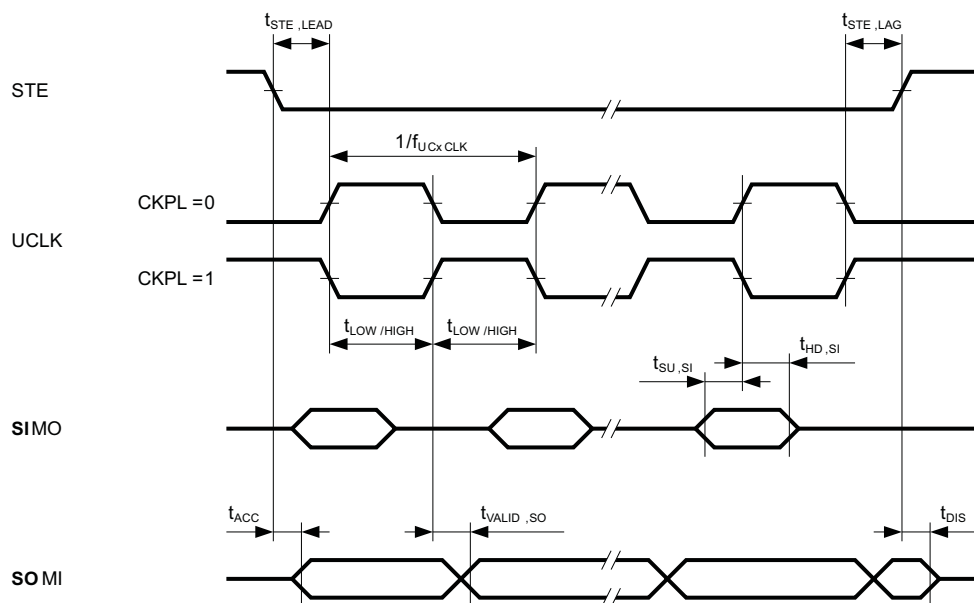

Figure 5-21. SPI Slave Mode, CKPH = 1

5.25 USCI (I²C Mode)

over recommended ranges of supply voltage and operating free-air temperature (unless otherwise noted) (see Figure 5-22)

PARAMETER	TEST CONDITIONS	V _{CC}	MIN	TYP	MAX	UNIT
f _{USCI}	USCI input clock frequency				f _{SYSTEM}	MHz
f _{SCL}	SCL clock frequency	2.2 V, 3 V	0		400	kHz
t _{HD,STA}	Hold time (repeated) START	f _{SCL} ≤ 100 kHz	2.2 V, 3 V	4		μs
		f _{SCL} > 100 kHz	2.2 V, 3 V	0.6		
t _{SU,STA}	Setup time for a repeated START	f _{SCL} ≤ 100 kHz	2.2 V, 3 V	4.7		μs
		f _{SCL} > 100 kHz	2.2 V, 3 V	0.6		
t _{HD,DAT}	Data hold time		2.2 V, 3 V	0		ns
t _{SU,DAT}	Data setup time		2.2 V, 3 V	250		ns
t _{SU,STO}	Setup time for STOP		2.2 V, 3 V	4		μs
t _{SP}	Pulse duration of spikes suppressed by input filter	2.2 V	50	150	600	ns
		3 V	50	100	600	

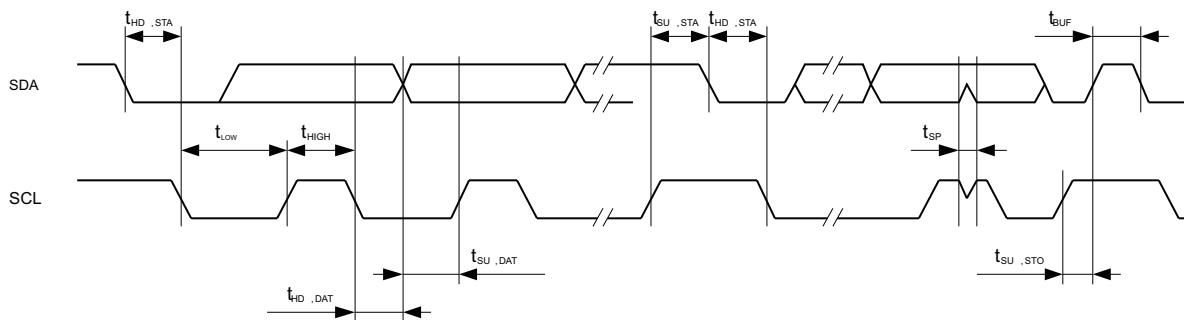

Figure 5-22. I²C Mode Timing

5.26 USART1

over recommended ranges of supply voltage and operating free-air temperature (unless otherwise noted)⁽¹⁾

PARAMETER	TEST CONDITIONS	MIN	TYP	MAX	UNIT
t _(T)	V _{CC} = 2.2 V, SYNC = 0, UART mode	200	430	800	ns
	V _{CC} = 3 V, SYNC = 0, UART mode	150	280	500	

(1) The signal applied to the USART1 receive signal (terminal) (URXD1) must meet the timing requirements of t_(T) to ensure that the URXS flip-flop is set. The URXS flip-flop is set with negative pulses that meet the minimum-timing condition of t_(T). The operating conditions to set the flag must be met independently from this timing constraint. The deglitch circuitry is active only on negative transitions on the URXD1 line.

5.27 12-Bit ADC, Power Supply and Input Range Conditions

over recommended ranges of supply voltage and operating free-air temperature (unless otherwise noted)⁽¹⁾

PARAMETER		TEST CONDITIONS	MIN	TYP	MAX	UNIT
V_{CC}	Analog supply voltage	V_{CC} and DV_{CC} are connected together, V_{SS} and DV_{SS} are connected together, $V_{(AVSS)} = V_{(DVSS)} = 0\text{ V}$	2.2		3.6	V
$V_{(P6.x/Ax)}$	Analog input voltage range ⁽²⁾	All external Ax terminals, Analog inputs selected in ADC12MCTLx register, P6Sel.x = 1, $V_{(AVSS)} \leq V_{Ax} \leq V_{(AVCC)}$	0		V_{AVCC}	V
I_{ADC12}	Operating supply current into V_{CC} terminal ⁽³⁾	$f_{ADC12CLK} = 5.0\text{ MHz}$, ADC12ON = 1, REFON = 0, SHT0 = 0, SHT1 = 0, ADC12DIV = 0	$V_{CC} = 2.2\text{ V}$	0.65	1.3	mA
			$V_{CC} = 3\text{ V}$	0.8	1.6	
I_{REF+}	Operating supply current into V_{CC} terminal ⁽⁴⁾	$f_{ADC12CLK} = 5.0\text{ MHz}$, ADC12ON = 0, REFON = 1, REF2_5V = 1	$V_{CC} = 3\text{ V}$	0.5	0.8	mA
		$f_{ADC12CLK} = 5.0\text{ MHz}$, ADC12ON = 0, REFON = 1, REF2_5V = 0	$V_{CC} = 2.2\text{ V}$	0.5	0.8	
C_i	Input capacitance	Only one terminal can be selected at one time, Ax	$V_{CC} = 2.2\text{ V}$		40	pF
R_i	Input MUX ON resistance	$0\text{ V} \leq V_{Ax} \leq V_{AVCC}$	$V_{CC} = 3\text{ V}$		2000	Ω

- (1) The leakage current is defined in the leakage current table with Ax parameter.
- (2) The analog input voltage range must be within the selected reference voltage range V_{R+} to V_{R-} for valid conversion results.
- (3) The internal reference supply current is not included in current consumption parameter I_{ADC12} .
- (4) The internal reference current is supplied from terminal V_{CC} . Consumption is independent of the ADC12ON control bit, unless a conversion is active. The REFON bit enables to settle the built-in reference before starting an A/D conversion.

5.28 12-Bit ADC, External Reference

over recommended ranges of supply voltage and operating free-air temperature (unless otherwise noted)⁽¹⁾

PARAMETER		TEST CONDITIONS	MIN	TYP	MAX	UNIT
V_{REF+}	Positive external reference voltage input	$V_{REF+} > V_{REF-}/V_{REF-}$ ⁽²⁾	1.4		V_{AVCC}	V
V_{REF-}/V_{REF-}	Negative external reference voltage input	$V_{REF+} > V_{REF-}/V_{REF-}$ ⁽³⁾	0		1.2	V
$(V_{REF+} - V_{REF-}/V_{REF-})$	Differential external reference voltage input	$V_{REF+} > V_{REF-}/V_{REF-}$ ⁽⁴⁾	1.4		V_{AVCC}	V
I_{VREF+}	Input leakage current	$0\text{ V} \leq V_{REF+} \leq V_{AVCC}$	$V_{CC} = 2.2\text{ V}, 3\text{ V}$		± 1	μA
I_{VREF-}/V_{REF-}	Input leakage current	$0\text{ V} \leq V_{REF-} \leq V_{AVCC}$	$V_{CC} = 2.2\text{ V}, 3\text{ V}$		± 1	μA

- (1) The external reference is used during conversion to charge and discharge the capacitance array. The input capacitance, C_i , is also the dynamic load for an external reference during conversion. The dynamic impedance of the reference supply should follow the recommendations on analog-source impedance to allow the charge to settle for 12-bit accuracy.
- (2) The accuracy limits the minimum positive external reference voltage. Lower reference voltage levels may be applied with reduced accuracy requirements.
- (3) The accuracy limits the maximum negative external reference voltage. Higher reference voltage levels may be applied with reduced accuracy requirements.
- (4) The accuracy limits minimum external differential reference voltage. Lower differential reference voltage levels may be applied with reduced accuracy requirements.

5.29 12-Bit ADC, Built-In Reference

over recommended ranges of supply voltage and operating free-air temperature (unless otherwise noted)

PARAMETER	TEST CONDITIONS	MIN	TYP	MAX	UNIT	
V_{REF+}	Positive built in reference voltage output REF2_5V = 1 for 2.5 V, $I_{VREF+max} \leq I_{VREF+} \leq I_{VREF+min}$	$V_{CC} = 3\text{ V}$	2.4	2.5	2.6	V
	REF2_5V = 0 for 1.5 V, $I_{VREF+max} \leq I_{VREF+} \leq I_{VREF+min}$	$V_{CC} = 2.2\text{ V}, 3\text{ V}$	1.44	1.5	1.56	
$AV_{CC(min)}$	AV_{CC} minimum voltage, Positive built in reference active REF2_5V = 0, $I_{VREF+max} \leq I_{VREF+} \leq I_{VREF+min}$		2.2			V
	REF2_5V = 1, $I_{VREF+min} \geq I_{VREF+} \geq -0.5\text{ mA}$		2.8			
	REF2_5V = 1, $I_{VREF+min} \geq I_{VREF+} \geq -1\text{ mA}$		2.9			
I_{VREF+}	Load current out of V_{REF+} terminal	$V_{CC} = 2.2\text{ V}$	0.01		-0.5	mA
		$V_{CC} = 3\text{ V}$	0.01		-1	
$I_{L(VREF+)}$	Load-current regulation, V_{REF+} terminal $I_{VREF+} = 500\text{ }\mu\text{A} \pm 100\text{ }\mu\text{A}$, Analog input voltage $\approx 0.75\text{ V}$, REF2_5V = 0	$V_{CC} = 2.2\text{ V}$			± 2	LSB
	$I_{VREF+} = 500\text{ }\mu\text{A} \pm 100\text{ }\mu\text{A}$, Analog input voltage $\approx 1.25\text{ V}$, REF2_5V = 1	$V_{CC} = 3\text{ V}$			± 2	
$I_{DL(VREF+)}$	Load current regulation, V_{REF+} terminal $I_{VREF+} = 100\text{ }\mu\text{A} \rightarrow 900\text{ }\mu\text{A}$, $C_{VREF+} = 5\text{ }\mu\text{F}$, $Ax \approx 0.5 \times V_{REF+}$, Error of conversion result $\leq 1\text{ LSB}$	$V_{CC} = 3\text{ V}$			20	ns
C_{VREF+}	Capacitance at pin V_{REF+} ⁽¹⁾ REFON = 1, $0\text{ mA} \leq I_{VREF+} \leq I_{VREF+max}$	$V_{CC} = 2.2\text{ V}, 3\text{ V}$	5	10		μF
T_{REF+}	Temperature coefficient of built-in reference I_{VREF+} is a constant in the range of $0\text{ mA} \leq I_{VREF+} \leq 1\text{ mA}$	$V_{CC} = 2.2\text{ V}, 3\text{ V}$			± 100	ppm/ $^{\circ}\text{C}$
t_{REFON}	Settling time of internal reference voltage (see Figure 5-23) ⁽²⁾ $I_{VREF+} = 0.5\text{ mA}$, $C_{VREF+} = 10\text{ }\mu\text{F}$, $V_{REF+} = 1.5\text{ V}$, $V_{AVCC} = 2.2\text{ V}$				17	ms

- (1) The internal buffer operational amplifier and the accuracy specifications require an external capacitor. All INL and DNL tests uses two capacitors between pins V_{REF+} and AV_{SS} and V_{REF-}/V_{eREF-} and AV_{SS} : 10- μF tantalum and 100-nF ceramic.
- (2) The condition is that the error in a conversion started after t_{REFON} is less than $\pm 0.5\text{ LSB}$. The settling time depends on the external capacitive load.

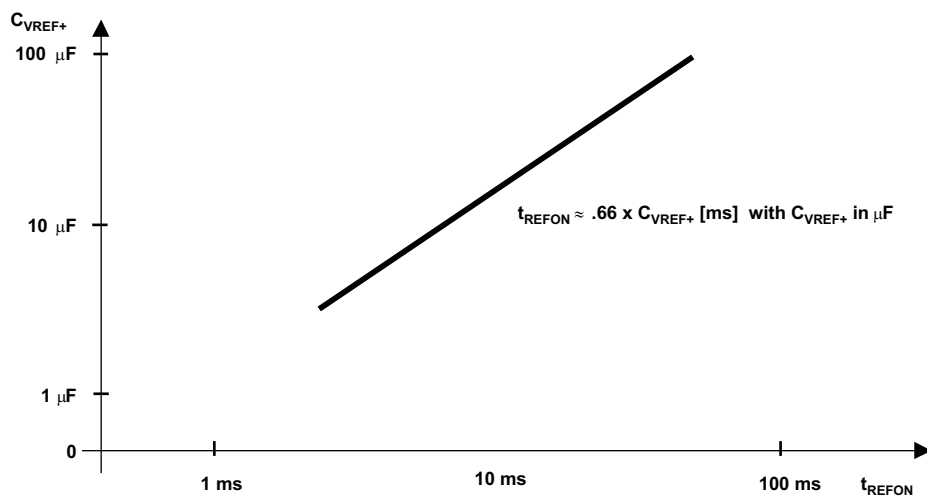

Figure 5-23. Typical Settling Time of Internal Reference t_{REFON} vs External Capacitor on V_{REF+}

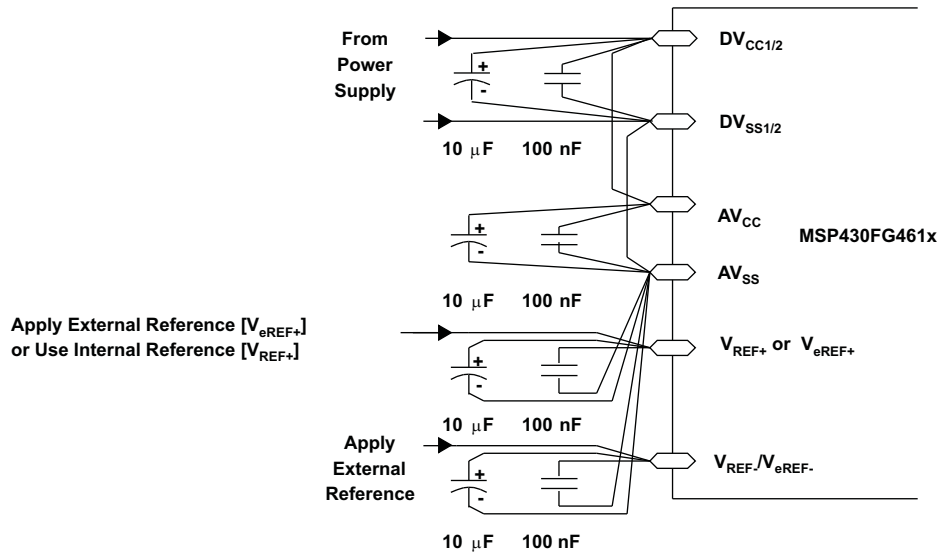

Figure 5-24. Supply Voltage and Reference Voltage Design V_{REF-}/V_{REF-} External Supply

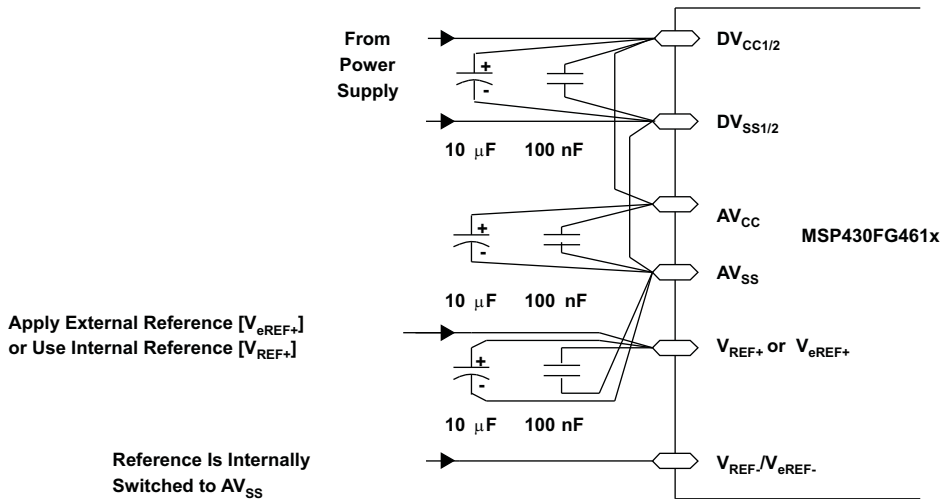

Figure 5-25. Supply Voltage and Reference Voltage Design $V_{REF-}/V_{REF-} = AV_{SS}$, Internally Connected

5.30 12-Bit ADC, Timing Parameters

over recommended ranges of supply voltage and operating free-air temperature (unless otherwise noted)

PARAMETER		TEST CONDITIONS	V _{CC}	MIN	TYP	MAX	UNIT
f _{ADC12CLK}		For specified performance of ADC12 linearity parameters	2.2 V, 3 V	0.45	5	6.3	MHz
f _{ADC12OSC}	Internal ADC12 oscillator	ADC12DIV = 0, f _{ADC12CLK} = f _{ADC12OSC}	2.2 V, 3 V	3.7	5	6.3	MHz
t _{CONVERT}	Conversion time	C _{VREF+} ≥ 5 μF, Internal oscillator, f _{ADC12OSC} = 3.7 MHz to 6.3 MHz External f _{ADC12CLK} from ACLK, MCLK, or SMCLK, ADC12SSEL ≠ 0	2.2 V, 3 V	2.06		3.51	μs
				13 × ADC12DIV × 1/f _{ADC12CLK}			
t _{ADC12ON}	Turnon settling time of the ADC	(1)				100	ns
t _{Sample}	Sampling time	R _S = 400 Ω, R _I = 1000 Ω, C _I = 30pF, τ = [R _S + R _I] × C _I (2)	3 V	1220			ns
			2.2 V	1400			

(1) The condition is that the error in a conversion started after t_{ADC12ON} is less than ±0.5 LSB. The reference and input signal are already settled.

(2) Approximately ten Tau (τ) are needed to get an error of less than ±0.5 LSB:

$$t_{\text{Sample}} = \ln(2^{n+1}) \times (R_S + R_I) \times C_I + 800 \text{ ns where } n = \text{ADC resolution} = 12, R_S = \text{external source resistance.}$$

5.31 12-Bit ADC, Linearity Parameters

over recommended ranges of supply voltage and operating free-air temperature (unless otherwise noted)

PARAMETER		TEST CONDITIONS	V _{CC}	MIN	TYP	MAX	UNIT
E _I	Integral linearity error	1.4 V ≤ (V _{REF+} - V _{REF-/V_{REF-}}) min ≤ 1.6 V 1.6 V < (V _{REF+} - V _{REF-/V_{REF-}}) min ≤ [V _{AVCC}]	2.2 V, 3 V			±2 ±1.7	LSB
E _D	Differential linearity error	(V _{REF+} - V _{REF-/V_{REF-}}) min ≤ (V _{REF+} - V _{REF-/V_{REF-}}), C _{VREF+} = 10 μF (tantalum) and 100 nF (ceramic)	2.2 V, 3 V			±1	LSB
E _O	Offset error	(V _{REF+} - V _{REF-/V_{REF-}}) min ≤ (V _{REF+} - V _{REF-/V_{REF-}}), Internal impedance of source R _S < 100 Ω, C _{VREF+} = 10 μF (tantalum) and 100 nF (ceramic)	2.2 V, 3 V		±2	±4	LSB
E _G	Gain error	(V _{REF+} - V _{REF-/V_{REF-}}) min ≤ (V _{REF+} - V _{REF-/V_{REF-}}), C _{VREF+} = 10 μF (tantalum) and 100 nF (ceramic)	2.2 V, 3 V		±1.1	±2	LSB
E _T	Total unadjusted error	(V _{REF+} - V _{REF-/V_{REF-}}) min ≤ (V _{REF+} - V _{REF-/V_{REF-}}), C _{VREF+} = 10 μF (tantalum) and 100 nF (ceramic)	2.2 V, 3 V		±2	±5	LSB

5.32 12-Bit ADC, Temperature Sensor and Built-In V_{MID}

over recommended ranges of supply voltage and operating free-air temperature (unless otherwise noted)

PARAMETER		TEST CONDITIONS	V_{CC}	MIN	TYP	MAX	UNIT
I_{SENSOR}	Operating supply current into AV_{CC} terminal ⁽¹⁾	REFON = 0, INCH = 0Ah, ADC12ON = N/A, $T_A = 25^\circ C$	2.2 V		40	120	μA
			3 V		60	160	
V_{SENSOR}	⁽²⁾	ADC12ON = 1, INCH = 0Ah, $T_A = 0^\circ C$	2.2 V, 3 V		986		mV
TC_{SENSOR}		ADC12ON = 1, INCH = 0Ah	2.2 V, 3 V		3.55 \pm 3%		mV/ $^\circ C$
$t_{SENSOR(sample)}$	Sample time required if channel 10 is selected ⁽³⁾	ADC12ON = 1, INCH = 0Ah, Error of conversion result \leq 1 LSB	2.2 V	30			μs
			3 V	30			
I_{VMID}	Current into divider at channel 11 ⁽⁴⁾	ADC12ON = 1, INCH = 0Bh	2.2 V			N/A ⁽⁴⁾	μA
			3 V			N/A ⁽⁴⁾	
V_{MID}	AV_{CC} divider at channel 11	ADC12ON = 1, INCH = 0Bh, $V_{MID} \approx 0.5 \times V_{AVCC}$	2.2 V		1.1	1.1 \pm 0.04	V
			3 V		1.5	1.50 \pm 0.04	
$t_{VMID(sample)}$	Sample time required if channel 11 is selected ⁽⁵⁾	ADC12ON = 1, INCH = 0Bh, Error of conversion result \leq 1 LSB	2.2 V	1400			ns
			3 V	1220			

- (1) The sensor current I_{SENSOR} is consumed if (ADC12ON = 1 and REFON = 1), or (ADC12ON = 1 AND INCH = 0Ah and sample signal is high). When REFON = 1, I_{SENSOR} is already included in I_{REF+} .
- (2) The temperature sensor offset can be as much as $\pm 20^\circ C$. TI recommends a single-point calibration to minimize the offset error of the built-in temperature sensor.
- (3) The typical equivalent impedance of the sensor is 51 k Ω . The sample time required includes the sensor-on time $t_{SENSOR(on)}$.
- (4) No additional current is needed. The V_{MID} is used during sampling.
- (5) The on-time $t_{VMID(on)}$ is included in the sampling time $t_{VMID(sample)}$; no additional on time is needed.

5.33 12-Bit DAC, Supply Specifications

over recommended ranges of supply voltage and operating free-air temperature (unless otherwise noted)

PARAMETER		TEST CONDITIONS	V_{CC}	MIN	TYP	MAX	UNIT
AV_{CC}	Analog supply voltage	$AV_{CC} = DV_{CC}$, $AV_{SS} = DV_{SS} = 0 V$		2.20		3.60	V
I_{DD}	Supply current, single DAC channel ^{(1) (2)}	DAC12AMPx = 2, DAC12IR = 0, DAC12_xDAT = 0800h	2.2 V, 3 V		50	110	μA
		DAC12AMPx = 2, DAC12IR = 1, DAC12_xDAT = 0800h, $V_{REF+} = V_{REF+} = AV_{CC}$			50	110	
		DAC12AMPx = 5, DAC12IR = 1, DAC12_xDAT = 0800h, $V_{REF+} = V_{REF+} = AV_{CC}$			200	440	
		DAC12AMPx = 7, DAC12IR = 1, DAC12_xDAT = 0800h, $V_{REF+} = V_{REF+} = AV_{CC}$			700	1500	
PSRR	Power-supply rejection ratio ⁽³⁾⁽⁴⁾	DAC12_xDAT = 800h, $V_{REF} = 1.5 V$, $\Delta AV_{CC} = 100 mV$	2.2 V		70		dB
		DAC12_xDAT = 800h, $V_{REF} = 1.5 V$ or 2.5 V, $\Delta AV_{CC} = 100 mV$	3 V				

- (1) No load at the output pin, DAC12_0 or DAC12_1, assuming that the control bits for the shared pins are set properly.
- (2) Current into reference terminals not included. If DAC12IR = 1 current flows through the input divider; see Reference Input specifications.
- (3) $PSRR = 20 \times \log\{\Delta AV_{CC}/\Delta V_{DAC12_xOUT}\}$.
- (4) V_{REF} is applied externally. The internal reference is not used.

5.34 12-Bit DAC, Linearity Specifications

over recommended ranges of supply voltage and operating free-air temperature (unless otherwise noted) (see Figure 5-26)

PARAMETER		TEST CONDITIONS	V _{CC}	MIN	TYP	MAX	UNIT
Resolution		12-bit monotonic		12			bits
INL	Integral nonlinearity ⁽¹⁾	V _{ref} = 1.5 V, DAC12AMP _x = 7, DAC12IR = 1	2.2 V	±2.0		±8.0	LSB
		V _{ref} = 2.5 V, DAC12AMP _x = 7, DAC12IR = 1	3 V				
DNL	Differential nonlinearity ⁽¹⁾	V _{ref} = 1.5 V, DAC12AMP _x = 7, DAC12IR = 1	2.2 V	±0.4		±1.0	LSB
		V _{ref} = 2.5 V, DAC12AMP _x = 7, DAC12IR = 1	3 V				
E _O	Offset voltage without calibration ^{(1) (2)}	V _{ref} = 1.5 V, DAC12AMP _x = 7, DAC12IR = 1	2.2 V	±30		±21	mV
		V _{ref} = 2.5 V, DAC12AMP _x = 7, DAC12IR = 1	3 V				
	Offset voltage with calibration ^{(1) (2)}	V _{ref} = 1.5 V, DAC12AMP _x = 7, DAC12IR = 1	2.2 V				
		V _{ref} = 2.5 V, DAC12AMP _x = 7, DAC12IR = 1	3 V				
d _{E(O)/dT}	Offset error temperature coefficient ⁽¹⁾		2.2 V, 3 V				µV/°C
E _G	Gain error ⁽¹⁾	V _{REF} = 1.5 V	2.2 V	±3.5			%FSR
		V _{REF} = 2.5 V	3 V				
d _{E(G)/dT}	Gain temperature coefficient ⁽¹⁾		2.2 V, 3 V		10		ppm of FSR/°C
t _{Offset_Cal}	Time for offset calibration ⁽³⁾	DAC12AMP _x = 2	2.2 V, 3 V			100	ms
		DAC12AMP _x = 3, 5				32	
		DAC12AMP _x = 4, 6, 7				6	

- (1) Parameters calculated from the best-fit curve from 0x0A to 0xFFF. The best-fit curve method is used to deliver coefficients “a” and “b” of the first order equation: $y = a + b \times x$. $V_{DAC12_xOUT} = E_O + (1 + E_G) \times (V_{REF}/4095) \times DAC12_xDAT$, DAC12IR = 1.
- (2) The offset calibration works on the output operational amplifier. Offset calibration is triggered by setting bit DAC12CALON.
- (3) The offset calibration can be done if DAC12AMP_x = {2, 3, 4, 5, 6, 7}. The output operational amplifier is switched off with DAC12AMP_x = {0, 1}. TI recommends that the DAC12 module be configured before initiating calibration. Port activity during calibration may effect accuracy and is not recommended.

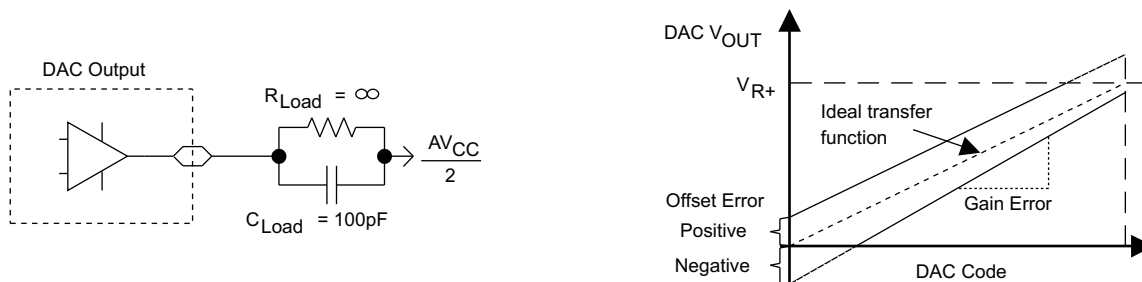

Figure 5-26. Linearity Test Load Conditions and Gain and Offset Definition

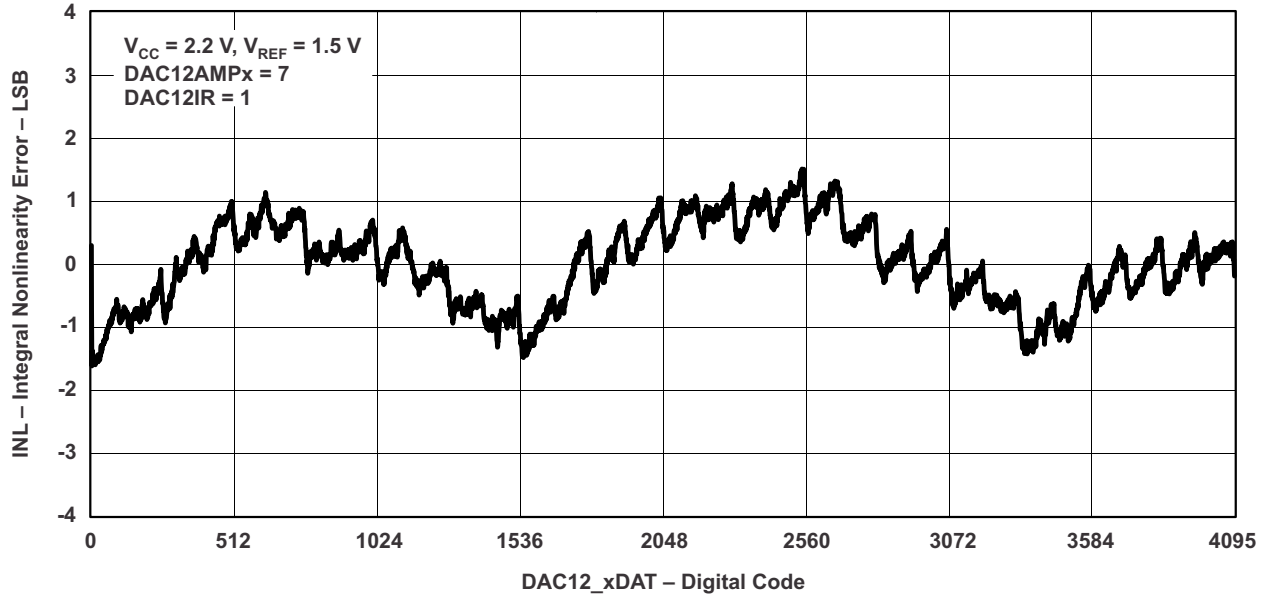

Figure 5-27. Typical INL Error vs Digital Input Data

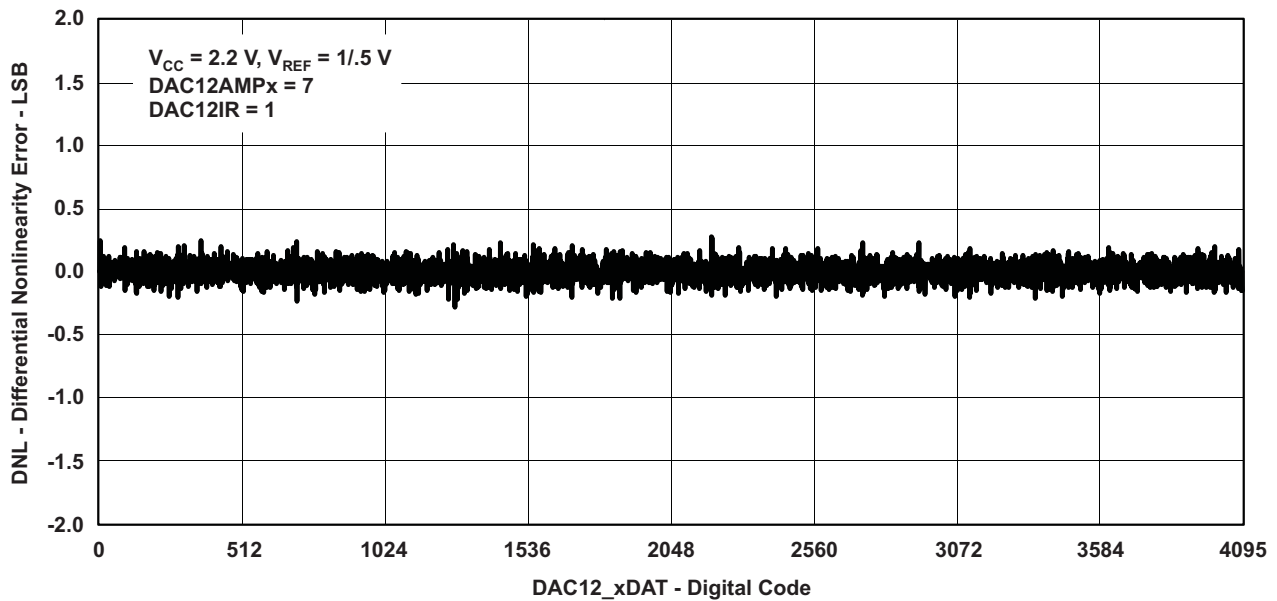

Figure 5-28. Typical DNL Error vs Digital Input Data

5.35 12-Bit DAC, Output Specifications

over recommended ranges of supply voltage and operating free-air temperature (unless otherwise noted)

PARAMETER		TEST CONDITIONS	V _{CC}	MIN	TYP	MAX	UNIT
V _O	Output voltage range (see Figure 5-29) ⁽¹⁾	No load, V _{REF+} = AV _{CC} , DAC12_xDAT = 0h, DAC12IR = 1, DAC12AMPx = 7	2.2 V, 3 V	0		0.005	V
		No load, V _{REF+} = AV _{CC} , DAC12_xDAT = 0FFFh, DAC12IR = 1, DAC12AMPx = 7		AV _{CC} - 0.05		AV _{CC}	
		R _{Load} = 3 kΩ, V _{REF+} = AV _{CC} , DAC12_xDAT = 0h, DAC12IR = 1, DAC12AMPx = 7		0		0.1	
		R _{Load} = 3 kΩ, V _{REF+} = AV _{CC} , DAC12_xDAT = 0FFFh, DAC12IR = 1, DAC12AMPx = 7		AV _{CC} - 0.13		AV _{CC}	
C _{L(DAC12)}	Max DAC12 load capacitance		2.2 V, 3 V			100	pF
I _{L(DAC12)}	Max DAC12 load current		2.2 V	-0.5		+0.5	mA
			3 V	-1.0		+1.0	
R _{O/P(DAC12)}	Output resistance (see Figure 5-29)	R _{Load} = 3 kΩ, V _{O/P(DAC12)} < 0.3 V, DAC12AMPx = 2, DAC12_xDAT = 0h	2.2 V, 3 V		150	250	Ω
		R _{Load} = 3 kΩ, V _{O/P(DAC12)} > AV _{CC} - 0.3 V, DAC12_xDAT = 0FFFh			150	250	
		R _{Load} = 3 kΩ, 0.3 V ≤ V _{O/P(DAC12)} ≤ AV _{CC} - 0.3 V			1	4	

(1) Data is valid after the offset calibration of the output amplifier.

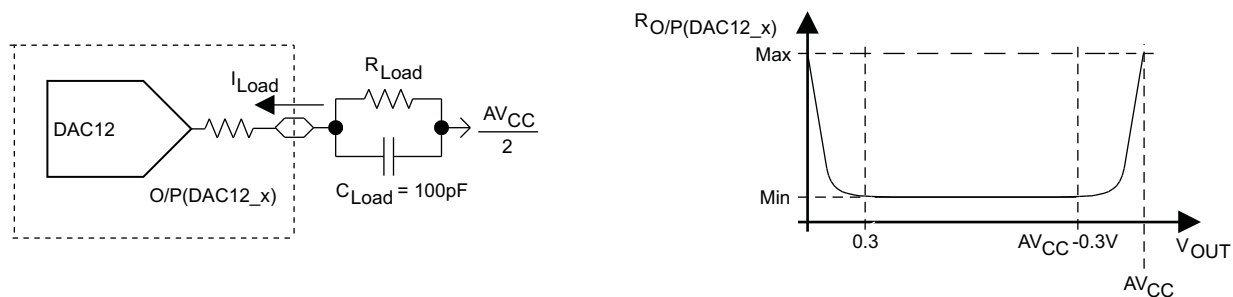

Figure 5-29. DAC12_x Output Resistance Tests

5.36 12-Bit DAC, Reference Input Specifications

over recommended ranges of supply voltage and operating free-air temperature (unless otherwise noted)

PARAMETER		TEST CONDITIONS	V _{CC}	MIN	TYP	MAX	UNIT
V _{REF+}	Reference input voltage range	DAC12IR = 0 ^{(1) (2)}	2.2 V, 3 V		AV _{CC} /3	AV _{CC} + 0.2	V
		DAC12IR = 1 ^{(3) (4)}			AV _{CC}	AV _{CC} + 0.2	
R _{i(VREF+)} , (R _{i(VREF+)})	Reference input resistance	DAC12_0 IR = DAC12_1 IR = 0	2.2 V, 3 V	20			MΩ
		DAC12_0 IR = 1, DAC12_1 IR = 0		40	48	56	kΩ
		DAC12_0 IR = 0, DAC12_1 IR = 1					
		DAC12_0 IR = DAC12_1 IR = 1, DAC12_0 SREFx = DAC12_1 SREFx ⁽⁵⁾		20	24	28	

(1) For a full-scale output, the reference input voltage can be as high as 1/3 of the maximum output voltage swing (AV_{CC}).

(2) The maximum voltage applied at reference input voltage terminal V_{REF+} = [AV_{CC} - V_{E(O)}] / [3 × (1 + E_G)].

(3) For a full-scale output, the reference input voltage can be as high as the maximum output voltage swing (AV_{CC}).

(4) The maximum voltage applied at reference input voltage terminal V_{REF+} = [AV_{CC} - V_{E(O)}] / (1 + E_G).

(5) When DAC12IR = 1 and DAC12SREFx = 0 or 1 for both channels, the reference input resistive dividers for each DAC are in parallel reducing the reference input resistance.

5.37 12-Bit DAC, Dynamic Specifications

$V_{ref} = V_{CC}$, DAC12IR = 1, over recommended ranges of supply voltage and operating free-air temperature (unless otherwise noted) (see Figure 5-30 and Figure 5-31)

PARAMETER		TEST CONDITIONS		V_{CC}	MIN	TYP	MAX	UNIT
t_{ON}	DAC12 on time	DAC12_xDAT = 800h, Error $_{V(O)}$ < ± 0.5 LSB ⁽¹⁾ (see Figure 5-30)	DAC12AMPx = 0 \rightarrow {2, 3, 4}	2.2 V, 3 V	60	120	μ s	
			DAC12AMPx = 0 \rightarrow {5, 6}		15	30		
			DAC12AMPx = 0 \rightarrow 7		6	12		
$t_{S(FS)}$	Settling time, full scale	DAC12_xDAT = 80h \rightarrow F7Fh \rightarrow 80h	DAC12AMPx = 2	2.2 V, 3 V	100	200	μ s	
			DAC12AMPx = 3, 5		40	80		
			DAC12AMPx = 4, 6, 7		15	30		
$t_{S(C-C)}$	Settling time, code to code	DAC12_xDAT = 3F8h \rightarrow 408h \rightarrow 3F8h BF8h \rightarrow C08h \rightarrow BF8h	DAC12AMPx = 2	2.2 V, 3 V	5	μ s		
			DAC12AMPx = 3, 5		2			
			DAC12AMPx = 4, 6, 7		1			
SR	Slew rate	DAC12_xDAT = 80h \rightarrow F7Fh \rightarrow 80h ⁽²⁾	DAC12AMPx = 2	2.2 V, 3 V	0.05	0.12	V/ μ s	
			DAC12AMPx = 3, 5		0.35	0.7		
			DAC12AMPx = 4, 6, 7		1.5	2.7		
	Glitch energy, full-scale	DAC12_xDAT = 80h \rightarrow F7Fh \rightarrow 80h	DAC12AMPx = 2	2.2 V, 3 V	600	nV-s		
			DAC12AMPx = 3, 5		150			
			DAC12AMPx = 4, 6, 7		30			

- (1) R_{Load} and C_{Load} connected to AV_{SS} (not $AV_{CC}/2$) in Figure 5-30.
(2) Slew rate applies to output voltage steps ≥ 200 mV.

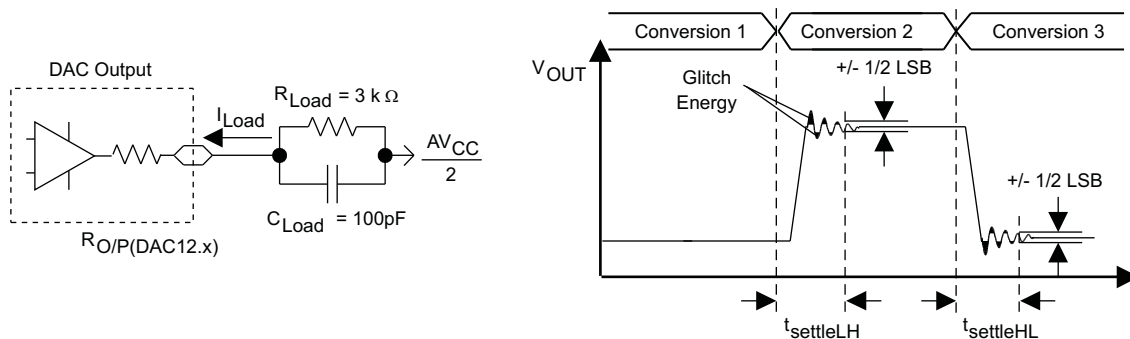

Figure 5-30. Settling Time and Glitch Energy Testing

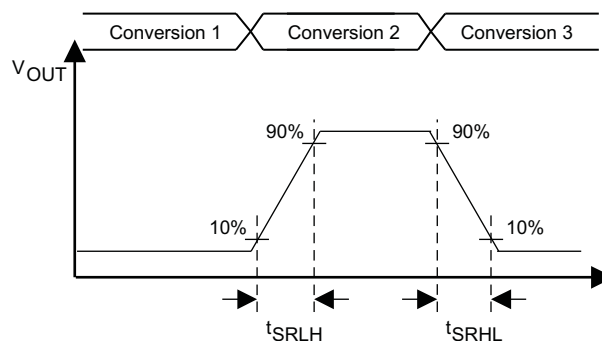

Figure 5-31. Slew Rate Testing

5.38 12-Bit DAC, Dynamic Specifications Continued

T_A = 25°C (unless otherwise noted)

PARAMETER	TEST CONDITIONS	V _{CC}	MIN	TYP	MAX	UNIT
BW _{-3dB} 3-dB bandwidth, V _{DC} = 1.5 V, V _{AC} = 0.1 VPP (see Figure 5-32)	DAC12AMP _x = {2, 3, 4}, DAC12SREF _x = 2, DAC12IR = 1, DAC12_xDAT = 800h	2.2 V, 3 V	40			kHz
	DAC12AMP _x = {5, 6}, DAC12SREF _x = 2, DAC12IR = 1, DAC12_xDAT = 800h		180			
	DAC12AMP _x = 7, DAC12SREF _x = 2, DAC12IR = 1, DAC12_xDAT = 800h		550			
Channel-to-channel crosstalk (see Figure 5-33) ⁽¹⁾	DAC12_0DAT = 800h, No Load, DAC12_1DAT = 80h ↔ F7Fh, R _{Load} = 3 kΩ f _{DAC12_1OUT} = 10 kHz at 50/50 duty cycle	2.2 V, 3 V		-80		dB
	DAC12_0DAT = 80h ↔ F7Fh, R _{Load} = 3 kΩ, DAC12_1DAT = 800h, No Load, f _{DAC12_0OUT} = 10 kHz at 50/50 duty cycle			-80		

(1) R_{LOAD} = 3 kΩ, C_{LOAD} = 100 pF

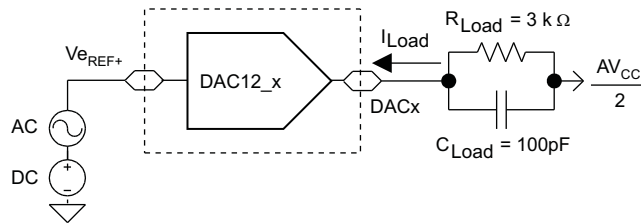

Figure 5-32. Test Conditions for 3-dB Bandwidth Specification

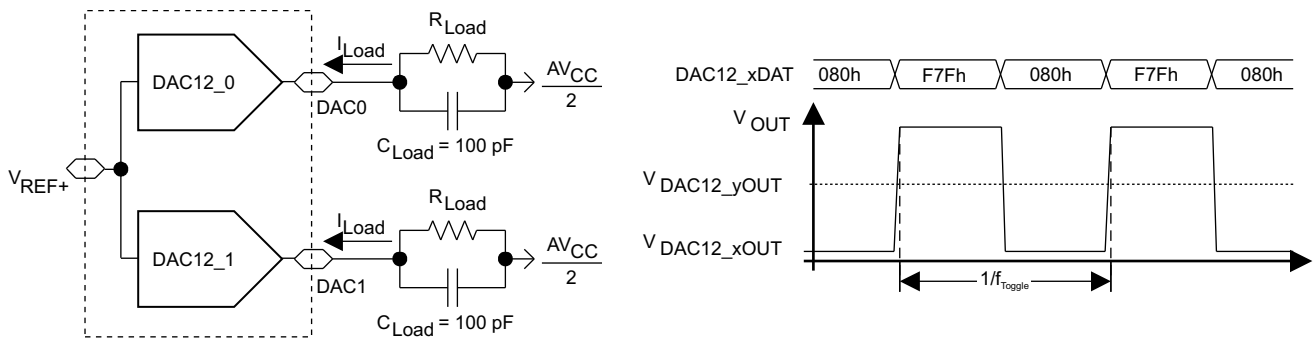

Figure 5-33. Crosstalk Test Conditions

5.39 Operational Amplifier OA, Supply Specifications

over recommended ranges of supply voltage and operating free-air temperature (unless otherwise noted)

PARAMETER		TEST CONDITIONS	V _{CC}	MIN	TYP	MAX	UNIT
V _{CC}	Supply voltage			2.2		3.6	V
I _{CC}	Supply current ⁽¹⁾	Fast Mode, OARRIP = 1 (rail-to-rail mode off)	2.2 V, 3 V		180	290	μA
		Medium Mode, OARRIP = 1 (rail-to-rail mode off)			110	190	
		Slow Mode, OARRIP = 1 (rail-to-rail mode off)			50	80	
		Fast Mode, OARRIP = 0 (rail-to-rail mode on)			300	490	
		Medium Mode, OARRIP = 0 (rail-to-rail mode on)			190	350	
		Slow Mode, OARRIP = 0 (rail-to-rail mode on)			90	190	
PSRR	Power supply rejection ratio	Noninverting	2.2 V, 3 V		70		dB

(1) P6SEL.x = 1 for each corresponding pin when used in OA input or OA output mode.

5.40 Operational Amplifier OA, Input/Output Specifications

over recommended ranges of supply voltage and operating free-air temperature (unless otherwise noted)

PARAMETER		TEST CONDITIONS	V _{CC}	MIN	TYP	MAX	UNIT	
V _{I/P}	Voltage supply, I/P	OARRIP = 1 (rail-to-rail mode off)		-0.1	V _{CC} - 1.2		V	
		OARRIP = 0 (rail-to-rail mode on)		-0.1	V _{CC} + 0.1			
I _{lkg}	Input leakage current, I/P ^{(1) (2)}	T _A = -40 to +55°C		-5	±0.5	5	nA	
		T _A = +55 to +85°C		-20	±5	20		
V _n	Voltage noise density, I/P	Fast Mode			50		nV/√Hz	
		Medium Mode		f _{V(I/P)} = 1 kHz		80		
		Slow Mode				140		
		Fast Mode		f _{V(I/P)} = 10 kHz		30		
		Medium Mode				50		
		Slow Mode				65		
V _{IO}	Offset voltage, I/P		2.2 V, 3 V			±10	mV	
	Offset temperature drift, I/P	⁽³⁾	2.2 V, 3 V		±10		μV/°C	
	Offset voltage drift with supply, I/P	0.3 V ≤ V _{IN} ≤ V _{CC} - 0.3 V ΔV _{CC} ≤ ±10%, T _A = 25°C	2.2 V, 3 V			±1.5	mV/V	
V _{OH}	High-level output voltage, O/P	Fast Mode, I _{SOURCE} ≤ -500 μA	2.2 V	V _{CC} - 0.2		V _{CC}	V	
		Slow Mode, I _{SOURCE} ≤ -150 μA	3 V	V _{CC} - 0.1		V _{CC}		
V _{OL}	Low-level output voltage, O/P	Fast Mode, I _{SOURCE} ≤ +500 μA	2.2 V	V _{SS}		0.2	V	
		Slow Mode, I _{SOURCE} ≤ +150 μA	3 V	V _{SS}		0.1		
R _{O/P (OAx)}	Output resistance (see Figure 5-34) ⁽⁴⁾	R _{Load} = 3 kΩ, C _{Load} = 50 pF, OARRIP = 0 (rail-to-rail mode on), V _{O/P(OAx)} < 0.2 V	2.2 V, 3 V		150	250	Ω	
		R _{Load} = 3 kΩ, C _{Load} = 50 pF, OARRIP = 0 (rail-to-rail mode on), V _{O/P(OAx)} > AV _{CC} - 0.2 V			150	250		
		R _{Load} = 3 kΩ, C _{Load} = 50 pF, OARRIP = 0 (rail-to-rail mode on), 0.2 V ≤ V _{O/P(OAx)} ≤ AV _{CC} - 0.2 V			0.1	4		
CMRR	Common-mode rejection ratio	Noninverting	2.2 V, 3 V		70		dB	

(1) ESD damage can degrade input current leakage.

(2) The input bias current is overridden by the input leakage current.

(3) Calculated using the box method.

(4) Specification valid for voltage-follower OAx configuration.

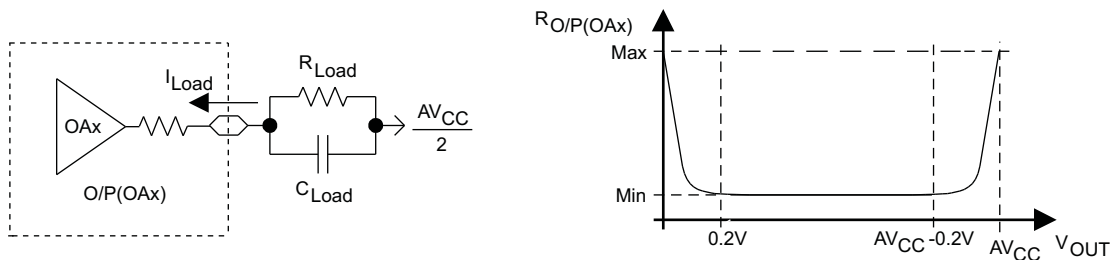

Figure 5-34. OAx Output Resistance Tests

5.41 Operational Amplifier OA, Dynamic Specifications

over recommended ranges of supply voltage and operating free-air temperature (unless otherwise noted)

PARAMETER		TEST CONDITIONS	V _{CC}	MIN	TYP	MAX	UNIT
SR	Slew rate	Fast Mode	2.2 V, 3 V		1.2		V/μs
		Medium Mode			0.8		
		Slow Mode			0.3		
	Open-loop voltage gain				100		dB
φ _m	Phase margin	C _L = 50 pF			60		deg
	Gain margin	C _L = 50 pF			20		dB
GBW	Gain-bandwidth product (see Figure 5-35 and Figure 5-36)	Noninverting, Fast Mode, R _L = 47 kΩ, C _L = 50 pF	2.2 V, 3 V		2.2		MHz
		Noninverting, Medium Mode, R _L = 300 kΩ, C _L = 50 pF			1.4		
		Noninverting, Slow Mode, R _L = 300 kΩ, C _L = 50 pF			0.5		
t _{en(on)}	Enable time on	t _{on} , Noninverting, Gain = 1	2.2 V, 3 V		10	20	μs
t _{en(off)}	Enable time off		2.2 V, 3 V			1	μs

5.42 Operational Amplifier OA, Typical Characteristics

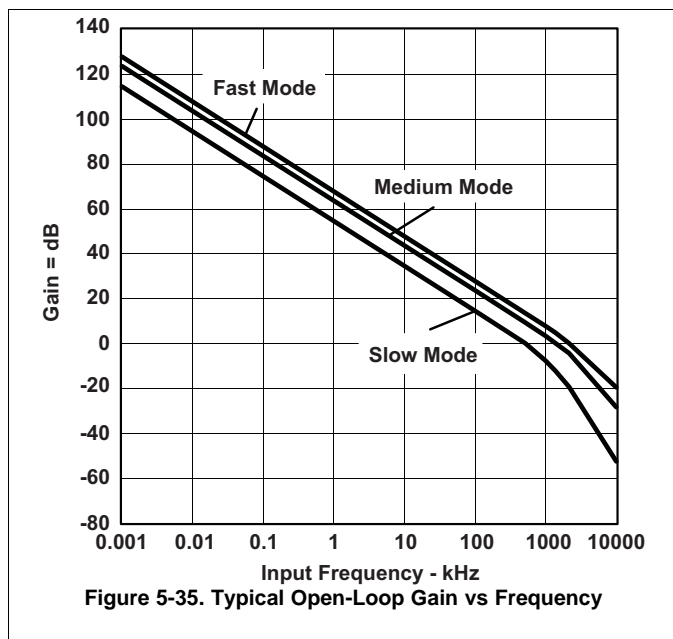

Figure 5-35. Typical Open-Loop Gain vs Frequency

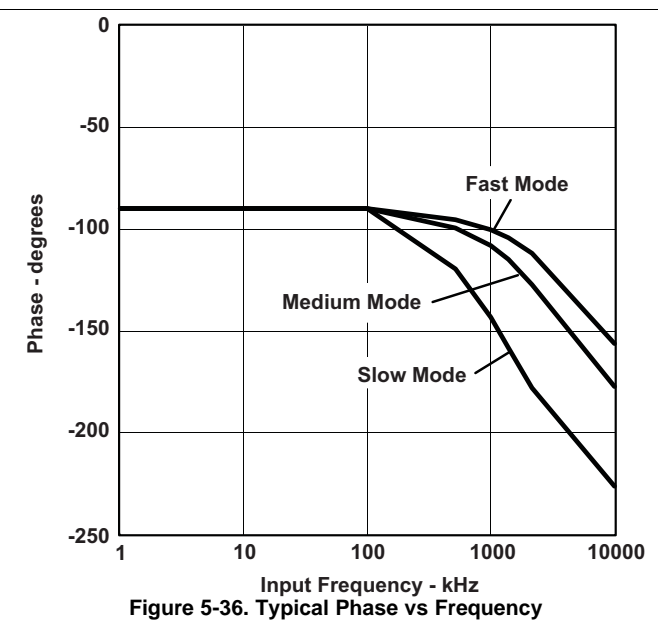

Figure 5-36. Typical Phase vs Frequency

5.43 Operational Amplifier OA Feedback Network, Noninverting Amplifier Mode (OAF_{Cx} = 4)

over recommended operating free-air temperature (unless otherwise noted)

PARAMETER		TEST CONDITIONS	V _{CC}	MIN	TYP	MAX	UNIT
G	Gain	OAFBR _x = 0	2.2 V, 3 V	0.996	1.00	1.002	
		OAFBR _x = 1		1.329	1.334	1.340	
		OAFBR _x = 2		1.987	2.001	2.016	
		OAFBR _x = 3		2.64	2.667	2.70	
		OAFBR _x = 4		3.93	4.00	4.06	
		OAFBR _x = 5		5.22	5.33	5.43	
		OAFBR _x = 6		7.76	7.97	8.18	
		OAFBR _x = 7		15.0	15.8	16.6	
THD	Total harmonic distortion and nonlinearity	All gains	2.2 V	-60		dB	
			3 V	-70			
t _{Settle}	Settling time ⁽¹⁾	All power modes	2.2 V, 3 V	7	12	μs	

(1) The settling time specifies the time until an ADC result is stable. This includes the minimum required sampling time of the ADC. The settling time of the amplifier itself might be faster.

5.44 Operational Amplifier OA Feedback Network, Inverting Amplifier Mode (OAF_{Cx} = 6)⁽¹⁾

over recommended operating free-air temperature (unless otherwise noted)

PARAMETER		TEST CONDITIONS	V _{CC}	MIN	TYP	MAX	UNIT
G	Gain	OAFBR _x = 1	2.2 V, 3 V	-0.371	-0.335	-0.298	
		OAFBR _x = 2		-1.031	-1.002	-0.972	
		OAFBR _x = 3		-1.727	-1.668	-1.609	
		OAFBR _x = 4		-3.142	-3.00	-2.856	
		OAFBR _x = 5		-4.581	-4.33	-4.073	
		OAFBR _x = 6		-7.529	-6.97	-6.379	
		OAFBR _x = 7		-17.040	-14.8	-12.279	
THD	Total harmonic distortion and nonlinearity	All gains	2.2 V	-60		dB	
			3 V	-70			
t _{Settle}	Settling time ⁽²⁾	All power modes	2.2 V, 3 V	7	12	μs	

(1) This includes the two OA configuration "inverting amplifier with input buffer". Both OAs need to be set to the same power mode, OAPM_x.

(2) The settling time specifies the time until an ADC result is stable. This includes the minimum required sampling time of the ADC. The settling time of the amplifier itself might be faster.

5.45 Flash Memory (FG461x Devices Only)

over recommended ranges of supply voltage and operating free-air temperature (unless otherwise noted)

PARAMETER		TEST CONDITIONS	V _{CC}	MIN	TYP	MAX	UNIT
V _{CC(PGM/ERASE)}	Program and erase supply voltage			2.7		3.6	V
f _{FTG}	Flash timing generator frequency			257		476	kHz
I _{PGM}	Supply current from DVCC during program		2.7 V, 3.6 V		3	5	mA
I _{ERASE}	Supply current from DVCC during erase	(1)	2.7 V, 3.6 V		3	7	mA
I _{GMERASE}	Supply current from DVCC during global mass erase	(2)	2.7 V, 3.6 V		6	14	mA
t _{CPT}	Cumulative program time	(3)	2.7 V, 3.6 V			10	ms
t _{CMErase}	Cumulative mass erase time		2.7 V, 3.6 V	20			ms
	Program and erase endurance			10 ⁴	10 ⁵		cycles
t _{Retention}	Data retention duration	T _J = 25°C		100			years
t _{Word}	Word or byte program time	(4)			30		t _{FTG}
t _{Block, 0}	Block program time for 1st byte or word				25		
t _{Block, 1-63}	Block program time for each additional byte or word				18		
t _{Block, End}	Block program end-sequence wait time				6		
t _{Mass Erase}	Mass erase time				10593		
t _{Global Mass Erase}	Global mass erase time				10593		
t _{Seg Erase}	Segment erase time				4819		

(1) Lower 64KB or upper 64KB flash memory erased.

(2) All flash memory erased.

(3) The cumulative program time must not be exceeded during a block-write operation. This parameter is only relevant if the block write feature is used.

(4) These values are hardwired into the flash controller state machine (t_{FTG} = 1/f_{FTG}).

5.46 JTAG Interface

over recommended ranges of supply voltage and operating free-air temperature (unless otherwise noted)

PARAMETER		TEST CONDITIONS	V _{CC}	MIN	TYP	MAX	UNIT
f _{TCK}	TCK input frequency	(1)	2.2 V	0		5	MHz
			3 V	0		10	
R _{Internal}	Internal pullup resistance on TMS, TCK, TDI/TCLK	(2)	2.2 V, 3 V	25	60	90	kΩ

(1) f_{TCK} may be restricted to meet the timing requirements of the module selected.

(2) TMS, TDI/TCLK, and TCK pullup resistors are implemented in all versions.

5.47 JTAG Fuse⁽¹⁾

over recommended operating free-air temperature range (unless otherwise noted)

PARAMETER		TEST CONDITIONS	MIN	MAX	UNIT
V _{CC(FB)}	Supply voltage during fuse-blow condition	T _A = 25°C	2.5		V
V _{FB}	Voltage level on TDI/TCLK for fuse-blow (FG461x)		6	7	V
I _{FB}	Supply current into TDI/TCLK during fuse blow			100	mA
t _{FB}	Time to blow fuse			1	ms

(1) After the fuse is blown, no further access to the MSP430 JTAG/Test and emulation features is possible. The JTAG block is switched to bypass mode.

6 Detailed Description

6.1 CPU

The MSP430 CPU has a 16-bit RISC architecture that is highly transparent to the application. All operations, other than program-flow instructions, are performed as register operations in conjunction with seven addressing modes for source operand and four addressing modes for destination operand.

The CPU is integrated with 16 registers that provide reduced instruction execution time. The register-to-register operation execution time is one cycle of the CPU clock.

Four of the registers, R0 to R3, are dedicated as program counter, stack pointer, status register, and constant generator, respectively. The remaining registers are general-purpose registers.

Peripherals are connected to the CPU using data, address, and control buses, and can be handled with all instructions.

The MSP430xG461x device family uses the MSP430X CPU and is completely backwards compatible with the MSP430 CPU. For a complete description of the MSP430X CPU, refer to the *MSP430x4xx Family User's Guide* ([SLAU056](#)).

Program Counter	PC/R0
Stack Pointer	SP/R1
Status Register	SR/CG1/R2
Constant Generator	CG2/R3
General-Purpose Register	R4
General-Purpose Register	R5
General-Purpose Register	R6
General-Purpose Register	R7
General-Purpose Register	R8
General-Purpose Register	R9
General-Purpose Register	R10
General-Purpose Register	R11
General-Purpose Register	R12
General-Purpose Register	R13
General-Purpose Register	R14
General-Purpose Register	R15

6.2 Instruction Set

The instruction set consists of the original 51 instructions with three formats and seven address modes and additional instructions for the expanded address range. Each instruction can operate on word and byte data. [Table 6-1](#) shows examples of the three types of instruction formats; the address modes are listed in [Table 6-2](#).

Table 6-1. Instruction Word Formats

FORMAT	EXAMPLE	OPERATION
Dual operands, source-destination	ADD R4,R5	R4 + R5 → R5
Single operands, destination only	CALL R8	PC → (TOS), R8 → PC
Relative jump, un/conditional	JNE	Jump-on-equal bit = 0

Table 6-2. Address Mode Descriptions

ADDRESS MODE	S ⁽¹⁾	D ⁽¹⁾	SYNTAX	EXAMPLE	OPERATION
Register	•	•	MOV Rs,Rd	MOV R10,R11	R10 → R11
Indexed	•	•	MOV X(Rn),Y(Rm)	MOV 2(R5),6(R6)	M(2+R5) → M(6+R6)
Symbolic (PC relative)	•	•	MOV EDE,TONI		M(EDE) → M(TONI)
Absolute	•	•	MOV & MEM, & TCDAT		M(MEM) → M(TCDAT)
Indirect	•		MOV @Rn,Y(Rm)	MOV @R10,Tab(R6)	M(R10) → M(Tab+R6)
Indirect autoincrement	•		MOV @Rn+,Rm	MOV @R10+,R11	M(R10) → R11 R10 + 2 → R10
Immediate	•		MOV #X,TONI	MOV #45,TONI	#45 → M(TONI)

(1) NOTE: S = source D = destination

6.3 Operating Modes

These devices have one active mode and five software-selectable low-power modes of operation. An interrupt event can wake up the device from any of the five low-power modes, service the request, and restore back to the low-power mode on return from the interrupt program.

The following six operating modes can be configured by software:

- Active mode (AM)
 - All clocks are active
- Low-power mode 0 (LPM0)
 - CPU is disabled
 - ACLK and SMCLK remain active. MCLK is disabled
 - FLL+ loop control remains active
- Low-power mode 1 (LPM1)
 - CPU is disabled
 - FLL+ loop control is disabled
 - ACLK and SMCLK remain active. MCLK is disabled
- Low-power mode 2 (LPM2)
 - CPU is disabled
 - MCLK, FLL+ loop control and DCOCLK are disabled
 - DCO DC generator remains enabled
 - ACLK remains active
- Low-power mode 3 (LPM3)
 - CPU is disabled
 - MCLK, FLL+ loop control, and DCOCLK are disabled
 - DCO DC generator is disabled
 - ACLK remains active
- Low-power mode 4 (LPM4)
 - CPU is disabled
 - ACLK is disabled
 - MCLK, FLL+ loop control, and DCOCLK are disabled
 - DCO DC generator is disabled
 - Crystal oscillator is stopped

6.4 Interrupt Vector Addresses

The interrupt vectors and the power-up start address are in the address range 0FFFFh to 0FFC0h. The vector contains the 16-bit address of the appropriate interrupt-handler instruction sequence.

Table 6-3. Interrupt Sources, Flags, and Vectors

INTERRUPT SOURCE	INTERRUPT FLAG	SYSTEM INTERRUPT	WORD ADDRESS	PRIORITY
Power-Up External Reset Watchdog Flash Memory	WDTIFG KEYV ^{(1) (2)}	Reset	0FFFEh	31, highest
NMI Oscillator Fault Flash Memory Access Violation	NMIIFG ^{(1) (3)} OFIFG ^{(1) (3)} ACCVIFG ^{(1) (4)(2)}	(Non)maskable (Non)maskable (Non)maskable	0FFFCh	30
Timer_B7	TBCCR0 CCIFG0 ⁽⁴⁾	Maskable	0FFFAh	29
Timer_B7	TBCCR1 CCIFG1 to TBCCR6 CCIFG6, TBIFG ⁽¹⁾⁽⁴⁾	Maskable	0FFF8h	28
Comparator_A	CAIFG	Maskable	0FFF6h	27
Watchdog Timer+	WDTIFG	Maskable	0FFF4h	26
USCI_A0, USCI_B0 Receive	UCA0RXIFG, UCB0RXIFG ⁽¹⁾	Maskable	0FFF2h	25
USCI_A0, USCI_B0 Transmit	UCA0TXIFG, UCB0TXIFG ⁽¹⁾	Maskable	0FFF0h	24
ADC12	ADC12IFG ^{(1) (4)}	Maskable	0FFEEh	23
Timer_A3	TACCR0 CCIFG0 ⁽⁴⁾	Maskable	0FFECCh	22
Timer_A3	TACCR1 CCIFG1 and TACCR2 CCIFG2, TAIFG ^{(1) (4)}	Maskable	0FFEAh	21
I/O Port P1 (Eight Flags)	P1IFG.0 to P1IFG.7 ^{(1) (4)}	Maskable	0FFE8h	20
USART1 Receive	URXIFG1	Maskable	0FFE6h	19
USART1 Transmit	UTXIFG1	Maskable	0FFE4h	18
I/O Port P2 (Eight Flags)	P2IFG.0 to P2IFG.7 ^{(1) (4)}	Maskable	0FFE2h	17
Basic Timer 1, RTC	BTIFG	Maskable	0FFE0h	16
DMA	DMA0IFG, DMA1IFG, DMA2IFG ^{(1) (4)}	Maskable	0FFDEh	15
DAC12	DAC12.0IFG, DAC12.1IFG ^{(1) (4)}	Maskable	0FFDCh	14
Reserved	Reserved ⁽⁵⁾		0FFDAh	13
			:	:
			0FFC0h	0, lowest

(1) Multiple source flags

(2) Access and key violations, KEYV and ACCVIFG, only applicable to FG devices.

(3) A reset is generated if the CPU tries to fetch instructions from within the module register memory address range (0h to 01FFh). (Non)maskable: the individual interrupt-enable bit can disable an interrupt event, but the general-interrupt enable cannot disable it.

(4) Interrupt flags are located in the module.

(5) The interrupt vectors at addresses 0FFDAh to 0FFC0h are not used in this device and can be used for regular program code if necessary.

6.5 Special Function Registers (SFRs)

The MSP430 SFRs are in the lowest address space and are organized as byte mode registers. SFRs should be accessed with byte instructions.

Legend

rw	Bit can be read and written.
rw-0, rw-1	Bit can be read and written. It is Reset or Set by PUC.
rw-(0), rw-(1)	Bit can be read and written. It is Reset or Set by POR.
	SFR bit is not present in device

6.5.1 Interrupt Enable 1 and 2

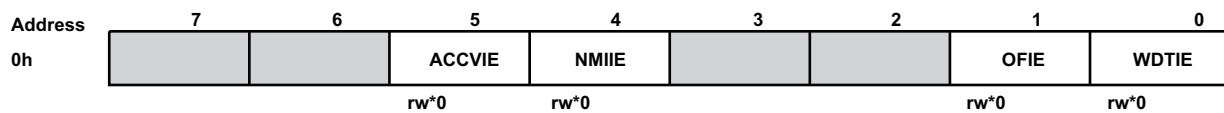

WDTIE Watchdog timer interrupt enable. Inactive if watchdog mode is selected.
Active if watchdog timer is configured as a general-purpose timer.

OFIE Oscillator fault-interrupt enable

NMIIE Nonmaskable interrupt enable

ACCVIE Flash access violation interrupt enable

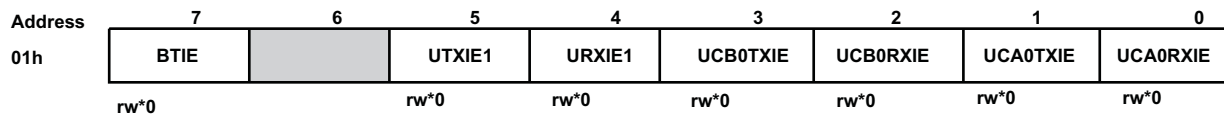

UCA0RXIE USCI_A0 receive-interrupt enable

UCA0TXIE USCI_A0 transmit-interrupt enable

UCB0RXIE USCI_B0 receive-interrupt enable

UCB0TXIE USCI_B0 transmit-interrupt enable

URXIE1 USART1 UART and SPI receive-interrupt enable

UTXIE1 USART1 UART and SPI transmit-interrupt enable

BTIE Basic timer interrupt enable

6.5.2 Interrupt Flag Register 1 and 2

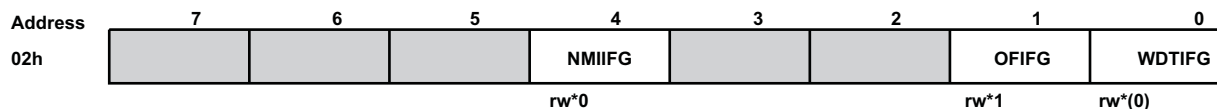

WDTIFG Set on watchdog timer overflow (in watchdog mode) or security key violation
Reset on V_{CC} power-on or a reset condition at the $\overline{\text{RST}}$ /NMI pin in reset mode

OFIFG Flag set on oscillator fault

NMIIFG Set by the $\overline{\text{RST}}$ /NMI pin

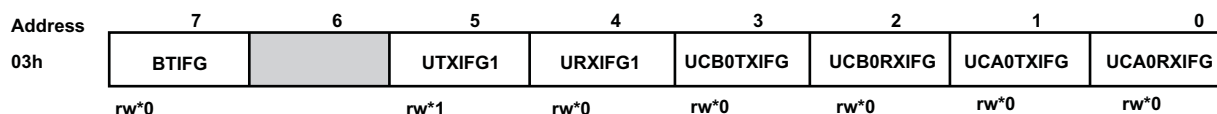

UCA0RXIFG USCI_A0 receive-interrupt flag

UCA0TXIFG USCI_A0 transmit-interrupt flag

UCB0RXIFG USCI_B0 receive-interrupt flag

UCB0TXIFG USCI_B0 transmit-interrupt flag

URXIFG0 USART1: UART and SPI receive flag

UTXIFG0 USART1: UART and SPI transmit flag

BTIFG Basic timer flag

6.5.3 Module Enable Registers 1 and 2

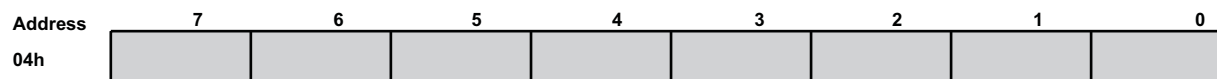

URXE1 USART1: UART mode receive enable

UTXE1 USART1: UART mode transmit enable

USPIE1 USART1: SPI mode transmit and receive enable

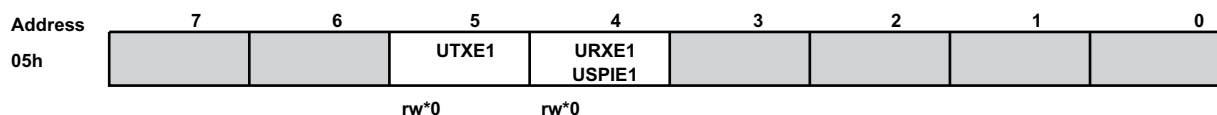

URXE1 USART1: UART mode receive enable

UTXE1 USART1: UART mode transmit enable

USPIE1 USART1: SPI mode transmit and receive enable

6.6 Memory Organization

Table 6-4 summarizes the memory organization for the FG461x devices, and Table 6-5 summarizes the memory organization for the CG461x devices.

Table 6-4. MSP430FG461x Memory Organization

			MSP430FG4616	MSP430FG4617	MSP430FG4618	MSP430FG4619
Memory Main: interrupt vector Main: code memory	Size		92KB	92KB	116KB	120KB
	Flash		0FFFFh-0FFC0h	0FFFFh-0FFC0h	0FFFFh-0FFC0h	0FFFFh-0FFC0h
	Flash		018FFFh-002100h	019FFFh-003100h	01FFFFh-003100h	01FFFFh-002100h
RAM	Total	Size	4KB	8KB	8KB	4KB
			020FFh-01100h	030FFh-01100h	030FFh-01100h	020FFh-01100h
	Extended	Size	2KB	6KB	6KB	2KB
			020FFh-01900h	030FFh-01900h	030FFh-01900h	020FFh-01900h
	Mirrored	Size	2KB	2KB	2KB	2KB
			018FFh-01100h	018FFh-01100h	018FFh-01100h	018FFh-01100h
Information memory	Size		256 Byte	256 Byte	256 Byte	256 Byte
	Flash		010FFh-01000h	010FFh-01000h	010FFh-01000h	010FFh-01000h
Boot memory	Size		1KB	1KB	1KB	1KB
	ROM		0FFFh-0C00h	0FFFh-0C00h	0FFFh-0C00h	0FFFh-0C00h
RAM (Mirrored at 018FFh-01100h)	Size		2KB	2KB	2KB	2KB
			09FFh-0200h	09FFh-0200h	09FFh-0200h	09FFh-0200h
Peripherals	16 bit		01FFh-0100h	01FFh-0100h	01FFh-0100h	01FFh-0100h
	8 bit		0FFh-010h	0FFh-010h	0FFh-010h	0FFh-010h
	8-bit SFR		0Fh-00h	0Fh-00h	0Fh-00h	0Fh-00h

Table 6-5. MSP430CG461x Memory Organization

			MSP430CG4616	MSP430CG4617	MSP430CG4618	MSP430CG4619
Memory Main: interrupt vector Main: code memory	Size		92KB	92KB	116KB	120KB
	ROM		0FFFFh-0FFC0h	0FFFFh-0FFC0h	0FFFFh-0FFC0h	0FFFFh-0FFC0h
	ROM		018FFFh-002100h	019FFFh-003100h	01FFFFh-003100h	01FFFFh-002100h
RAM	Total	Size	4KB	8KB	8KB	4KB
			020FFh-01100h	030FFh-01100h	030FFh-01100h	020FFh-01100h
	Extended	Size	2KB	6KB	6KB	2KB
			020FFh-01900h	030FFh-01900h	030FFh-01900h	020FFh-01900h
	Mirrored	Size	2KB	2KB	2KB	2KB
			018FFh-01100h	018FFh-01100h	018FFh-01100h	018FFh-01100h
Information memory	Size		256 Byte	256 Byte	256 Byte	256 Byte
	ROM		010FFh-01000h	010FFh-01000h	010FFh-01000h	010FFh-01000h
Boot memory (Optional on CG)	Size		1KB	1KB	1KB	1KB
	ROM		0FFFh-0C00h	0FFFh-0C00h	0FFFh-0C00h	0FFFh-0C00h
RAM (Mirrored at 018FFh-01100h)	Size		2KB	2KB	2KB	2KB
			09FFh-0200h	09FFh-0200h	09FFh-0200h	09FFh-0200h
Peripherals	16 bit		01FFh-0100h	01FFh-0100h	01FFh-0100h	01FFh-0100h
	8 bit		0FFh-010h	0FFh-010h	0FFh-010h	0FFh-010h
	8-bit SFR		0Fh-00h	0Fh-00h	0Fh-00h	0Fh-00h

6.7 Bootstrap Loader (BSL)

The BSL lets users program the flash memory or RAM using a UART serial interface. Access to the MCU memory through the BSL is protected by user-defined password. A bootstrap loader security key is provided at address 0FFBEh to disable the BSL completely or to disable the erasure of the flash if an invalid password is supplied. The BSL is optional for ROM-based devices. For complete description of the features of the BSL and its implementation, see the application report *Features of the MSP430 Bootstrap Loader* ([SLAA089](#)).

BSLKEY	DESCRIPTION
00000h	Erase of flash disabled if an invalid password is supplied
0AA55h	BSL disabled
any other value	BSL enabled

BSL FUNCTION	PZ/ZQW PACKAGE PINS
Data Transmit	87/A7 – P1.0
Data Receiver	86/E7 – P1.1

6.8 Flash Memory

The flash memory can be programmed by the JTAG port, the bootstrap loader, or in system by the CPU. The CPU can perform single-byte and single-word writes to the flash memory. Features of the flash memory include:

- Flash memory has n segments of main memory and two segments of information memory (A and B) of 128 bytes each. Each segment in main memory is 512 bytes in size.
- Segments 0 to n may be erased in one step, or each segment may be individually erased.
- Segments A and B can be erased individually, or as a group with segments 0-n. Segments A and B are also called information memory.
- New devices may have some bytes programmed in the information memory (needed for test during manufacturing). The user should perform an erase of the information memory before the first use.

6.9 Peripherals

Peripherals are connected to the CPU through data, address, and control buses. Peripherals can be handled using all instructions. For complete module descriptions, refer to the *MSP430x4xx Family User's Guide*.

6.9.1 DMA Controller

The DMA controller allows movement of data from one memory address to another without CPU intervention. For example, the DMA controller can be used to move data from the ADC12 conversion memory to RAM. Using the DMA controller can increase the throughput of peripheral modules. The DMA controller reduces system power consumption by allowing the CPU to remain in sleep mode without having to awaken to move data to or from a peripheral.

6.9.2 Oscillator and System Clock

The clock system in the MSP430xG461x family of devices is supported by the FLL+ module, which includes support for a 32768-Hz watch crystal oscillator, an internal digitally controlled oscillator (DCO), and a high-frequency crystal oscillator. The FLL+ clock module is designed to meet the requirements of both low system cost and low power consumption. The FLL+ features digital frequency locked loop (FLL) hardware that, in conjunction with a digital modulator, stabilizes the DCO frequency to a programmable multiple of the watch crystal frequency. The internal DCO provides a fast turnon clock source and stabilizes in less than 6 μ s. The FLL+ module provides the following clock signals:

- Auxiliary clock (ACLK), sourced from a 32768-Hz watch crystal or a high-frequency crystal
- Main clock (MCLK), the system clock used by the CPU
- Submain clock (SMCLK), the subsystem clock used by the peripheral modules
- ACLK/n, the buffered output of ACLK, ACLK/2, ACLK/4, or ACLK/8

6.9.3 Brownout, Supply Voltage Supervisor (SVS)

The brownout circuit provides the proper internal reset signal to the device during power-on and power-off. The SVS circuitry detects if the supply voltage drops below a user-selectable level and supports both supply voltage supervision (the device is automatically reset) and supply voltage monitoring (the device is not automatically reset).

The CPU begins code execution after the brownout circuit releases the device reset. However, V_{CC} may not have ramped to $V_{CC(\min)}$ at that time. The user must make sure the default FLL+ settings are not changed until V_{CC} reaches $V_{CC(\min)}$. If desired, the SVS circuit can be used to determine when V_{CC} reaches $V_{CC(\min)}$.

6.9.4 Digital I/O

There are ten 8-bit I/O ports implemented—ports P1 through P10:

- All individual I/O bits are independently programmable.
- Any combination of input, output, and interrupt conditions is possible.
- Edge-selectable interrupt input capability for all the eight bits of ports P1 and P2.
- Read and write access to port-control registers is supported by all instructions
- Ports P7/P8 and P9/P10 can be accessed word-wise as ports PA and PB, respectively.

6.9.5 Basic Timer1 and Real-Time Clock

The Basic Timer1 has two independent 8-bit timers that can be cascaded to form a 16-bit timer/counter. Both timers can be read and written by software. Basic Timer1 is extended to provide an integrated real-time clock (RTC). An internal calendar compensates for months with less than 31 days and includes leap-year correction.

6.9.6 LCD_A Drive With Regulated Charge Pump

The LCD_A driver generates the segment and common signals required to drive a segment LCD display. The LCD_A controller has dedicated data memory to hold segment drive information. Common and segment signals are generated as defined by the mode. Static, 2-MUX, 3-MUX, and 4-MUX LCDs are supported by this peripheral. The module can provide a LCD voltage independent of the supply voltage with its integrated charge pump. Furthermore it is possible to control the level of the LCD voltage and, thus, contrast by software.

6.9.7 Watchdog Timer (WDT+)

The primary function of the WDT+ module is to perform a controlled system restart after a software problem occurs. If the selected time interval expires, a system reset is generated. If the watchdog function is not needed in an application, the module can be configured as an interval timer and can generate interrupts at selected time intervals.

6.9.8 Universal Serial Communication Interface (USCI)

The USCI modules are used for serial data communication. The USCI module supports synchronous communication protocols like SPI (3-pin or 4-pin), I²C, and asynchronous communication protocols like UART, enhanced UART with automatic baudrate detection, and IrDA.

The USCI_A0 module provides support for SPI (3-pin or 4-pin), UART, enhanced UART and IrDA.

The USCI_B0 module provides support for SPI (3-pin or 4-pin) and I²C.

6.9.9 USART1

The hardware universal synchronous/asynchronous receive transmit (USART) peripheral module is used for serial data communication. The USART supports synchronous SPI (3-pin or 4-pin) and asynchronous UART communication protocols, using double-buffered transmit and receive channels.

6.9.10 Hardware Multiplier

The multiplication operation is supported by a dedicated peripheral module. The module performs 16×16, 16×8, 8×16, and 8×8 bit operations. The module supports signed and unsigned multiplication as well as signed and unsigned multiply-and-accumulate operations. The result of an operation can be accessed immediately after the operands have been loaded into the peripheral registers. No additional clock cycles are required.

6.9.11 Timer_A3

Timer_A3 is a 16-bit timer/counter with three capture/compare registers. Timer_A3 can support multiple capture/compares, PWM outputs, and interval timing. Timer_A3 also has extensive interrupt capabilities. Interrupts may be generated from the counter on overflow conditions and from each of the capture/compare registers.

Table 6-6. Timer_A3 Signal Connections

INPUT PIN NUMBER	DEVICE INPUT SIGNAL	MODULE INPUT NAME	MODULE BLOCK	MODULE OUT SIGNAL	OUTPUT PIN NUMBER
PZ/QZW					PZ/QZW
82/B9 - P1.5	TACLK	TACLK	Timer	NA	
	ACLK	ACLK			
	SMCLK	SMCLK			
82/B9 - P1.5	$\overline{\text{TACLK}}$	INCLK			
87/A7 - P1.0	TA0	CCI0A	CCR0	TA0	87/A7 - P1.0
86/E7 - P1.1	TA0	CCI0B			
	DV _{SS}	GND			
	DV _{CC}	V _{CC}			
85/D7 - P1.2	TA1	CCI1A	CCR1	TA1	85/D7 - P1.2
	CAOUT (internal)	CCI1B			ADC12 (internal)
	DV _{SS}	GND			
	DV _{CC}	V _{CC}			
79/A10 - P2.0	TA2	CCI2A	CCR2	TA2	79/A10 - P2.0
	ACLK (internal)	CCI2B			
	DV _{SS}	GND			
	DV _{CC}	V _{CC}			

6.9.12 Timer_B7

Timer_B7 is a 16-bit timer/counter with seven capture/compare registers. Timer_B7 can support multiple capture/comparers, PWM outputs, and interval timing. Timer_B7 also has extensive interrupt capabilities. Interrupts may be generated from the counter on overflow conditions and from each of the capture/compare registers.

Table 6-7. Timer_B7 Signal Connections

INPUT PIN NUMBER	DEVICE INPUT SIGNAL	MODULE INPUT NAME	MODULE BLOCK	MODULE OUT SIGNAL	OUTPUT PIN NUMBER
PZ/QZW					PZ/QZW
83/B8 - P1.4	TBCLK	TBCLK	Timer	NA	
	ACLK	ACLK			
	SMCLK	SMCLK			
83/B8 - P1.4	TBCLK	INCLK	CCR0CCR0	TB0TB0	
78/D8 - P2.1	TB0	CCI0A			
78/D8 - P2.1	TB0	CCI0B			
	DV _{SS}	GND			
	DV _{CC}	V _{CC}			
77/E8 - P2.2	TB1	CCI1A	CCR1	TB1	77/E8 - P2.2
77/E8 - P2.2	TB1	CCI1B			ADC12 (internal)
	DV _{SS}	GND			
	DV _{CC}	V _{CC}			
76/A11 - P2.3	TB2	CCI2A	CCR2	TB2	76/A11 - P2.3
76/A11 - P2.3	TB2	CCI2B			
	DV _{SS}	GND			
	DV _{CC}	V _{CC}			
67/E12 - P3.4	TB3	CCI3A	CCR3	TB3	67/E12 - P3.4
67/E12 - P3.4	TB3	CCI3B			
	DV _{SS}	GND			
	DV _{CC}	V _{CC}			
66/G9 - P3.5	TB4	CCI4A	CCR4	TB4	66/G9 - P3.5
66/G9 - P3.5	TB4	CCI4B			
	DV _{SS}	GND			
	DV _{CC}	V _{CC}			
65/F11 - P3.6	TB5	CCI5A	CCR5	TB5	65/F11 - P3.6
65/F11 - P3.6	TB5	CCI5B			
	DV _{SS}	GND			
	DV _{CC}	V _{CC}			
64/F12 - P3.7	TB6	CCI6A	CCR6	TB6	64/F12 - P3.7
	ACLK (internal)	CCI6B			
	DV _{SS}	GND			
	DV _{CC}	V _{CC}			

6.9.13 Comparator_A

The primary function of the comparator_A module is to support precision slope analog-to-digital conversions, battery-voltage supervision, and monitoring of external analog signals.

6.9.14 ADC12

The ADC12 module supports fast, 12-bit analog-to-digital conversions. The module implements a 12-bit SAR core, sample select control, reference generator and a 16 word conversion-and-control buffer. The conversion-and-control buffer allows up to 16 independent ADC samples to be converted and stored without any CPU intervention.

6.9.15 DAC12

The DAC12 module is a 12-bit R-ladder voltage-output DAC. The DAC12 can be used in 8-bit or 12-bit mode and can be used in conjunction with the DMA controller. When multiple DAC12 modules are present, they may be grouped together for synchronous operation.

6.9.16 OA

The MSP430xG461x has three configurable low-current general-purpose operational amplifiers. Each OA input and output terminal is software-selectable and offer a flexible choice of connections for various applications. The OA op amps primarily support front-end analog signal conditioning before analog-to-digital conversion.

Table 6-8. OA Signal Connections

INPUT PIN NUMBER	DEVICE INPUT SIGNAL	MODULE INPUT NAME	MODULE BLOCK	MODULE OUTPUT SIGNAL	DEVICE OUTPUT SIGNAL	OUTPUT PIN NUMBER
PZ						PZ
95 - P6.0	OA0I0	OA0I0	OA0	OA0OUT	OA0O	96 - P6.1
97 - P6.2	OA0I1	OA0I1			OA0O	ADC12 (internal)
	DAC12_0OUT (internal)	DAC12_0OUT				
	DAC12_1OUT (internal)	DAC12_1OUT				
3- P6.4	OA1I0	OA1I0	OA1	OA1OUT	OA1O	2- P6.3
13 - P5.0	OA1I1	OA1I1			OA1O	13- P5.0
	DAC12_0OUT (internal)	DAC12_0OUT			OA1O	ADC12 (internal)
	DAC12_1OUT (internal)	DAC12_1OUT				
5- P6.6	OA2I0	OA2I0	OA2	OA2OUT	OA2O	4- P6.5
14 - P10.7	OA2I1	OA2I1			OA2O	14 - P10.7
	DAC12_0OUT (internal)	DAC12_0OUT			OA2O	ADC12 (internal)
	DAC12_1OUT (internal)	DAC12_1OUT				

6.9.17 Peripheral File Map

Table 6-9 lists the registers and addresses for peripherals with word access. Table 6-10 lists the registers and addresses for peripherals with byte access.

Table 6-9. Peripherals With Word Access

MODULE	REGISTER NAME	ACRONYM	ADDRESS
Watchdog+	Watchdog timer control	WDTCTL	0120h
Timer_B7	Capture/compare register 6 Capture/compare register 5 Capture/compare register 4 Capture/compare register 3 Capture/compare register 2 Capture/compare register 1 Capture/compare register 0 Timer_B register Capture/compare control 6 Capture/compare control 5 Capture/compare control 4 Capture/compare control 3 Capture/compare control 2 Capture/compare control 1 Capture/compare control 0 Timer_B control Timer_B interrupt vector	TBCCR6 TBCCR5 TBCCR4 TBCCR3 TBCCR2 TBCCR1 TBCCR0 TBR TBCCTL6 TBCCTL5 TBCCTL4 TBCCTL3 TBCCTL2 TBCCTL1 TBCCTL0 TBCTL TBIV	019Eh 019Ch 019Ah 0198h 0196h 0194h 0192h 0190h 018Eh 018Ch 018Ah 0188h 0186h 0184h 0182h 0180h 011Eh
Timer_A3	Capture/compare register 2 Capture/compare register 1 Capture/compare register 0 Timer_A register Capture/compare control 2 Capture/compare control 1 Capture/compare control 0 Timer_A control Timer_A interrupt vector	TACCR2 TACCR1 TACCR0 TAR TACCTL2 TACCTL1 TACCTL0 TACTL TAIV	0176h 0174h 0172h 0170h 0166h 0164h 0162h 0160h 012Eh
Hardware Multiplier	Sum extend Result high word Result low word Second operand Multiply signed + accumulate/operand1 Multiply + accumulate/operand1 Multiply signed/operand1 Multiply unsigned/operand1	SUMEXT RESHI RESLO OP2 MACS MAC MPYS MPY	013Eh 013Ch 013Ah 0138h 0136h 0134h 0132h 0130h
Flash (FG devices only)	Flash control 3 Flash control 2 Flash control 1	FCTL3 FCTL2 FCTL1	012Ch 012Ah 0128h
DMA	DMA module control 0 DMA module control 1 DMA interrupt vector	DMACTL0 DMACTL1 DMAIV	0122h 0124h 0126h
DMA Channel 0	DMA channel 0 control DMA channel 0 source address DMA channel 0 destination address DMA channel 0 transfer size	DMA0CTL DMA0SA DMA0DA DMA0SZ	01D0h 01D2h 01D6h 01DAh
DMA Channel 1	DMA channel 1 control DMA channel 1 source address DMA channel 1 destination address DMA channel 1 transfer size	DMA1CTL DMA1SA DMA1DA DMA1SZ	01DCh 01DEh 01E2h 01E6h
DMA Channel 2	DMA channel 2 control DMA channel 2 source address DMA channel 2 destination address DMA channel 2 transfer size	DMA2CTL DMA2SA DMA2DA DMA2SZ	01E8h 01EAh 01EEh 01F2h

Table 6-9. Peripherals With Word Access (continued)

MODULE	REGISTER NAME	ACRONYM	ADDRESS
ADC12 See also Table 6-10	Conversion memory 15	ADC12MEM15	015Eh
	Conversion memory 14	ADC12MEM14	015Ch
	Conversion memory 13	ADC12MEM13	015Ah
	Conversion memory 12	ADC12MEM12	0158h
	Conversion memory 11	ADC12MEM11	0156h
	Conversion memory 10	ADC12MEM10	0154h
	Conversion memory 9	ADC12MEM9	0152h
	Conversion memory 8	ADC12MEM8	0150h
	Conversion memory 7	ADC12MEM7	014Eh
	Conversion memory 6	ADC12MEM6	014Ch
	Conversion memory 5	ADC12MEM5	014Ah
	Conversion memory 4	ADC12MEM4	0148h
	Conversion memory 3	ADC12MEM3	0146h
	Conversion memory 2	ADC12MEM2	0144h
	Conversion memory 1	ADC12MEM1	0142h
	Conversion memory 0	ADC12MEM0	0140h
	Interrupt-vector-word register	ADC12IV	01A8h
	Inerrupt-enable register	ADC12IE	01A6h
Inerrupt-flag register	ADC12IFG	01A4h	
Control register 1	ADC12CTL1	01A2h	
Control register 0	ADC12CTL0	01A0h	
DAC12	DAC12_1 data	DAC12_1DAT	01CAh
	DAC12_1 control	DAC12_1CTL	01C2h
	DAC12_0 data	DAC12_0DAT	01C8h
	DAC12_0 control	DAC12_0CTL	01C0h
Port PA	Port PA selection	PASEL	03Eh
	Port PA direction	PADIR	03Ch
	Port PA output	PAOUT	03Ah
	Port PA input	PAIN	038h
Port PB	Port PB selection	PBSEL	00Eh
	Port PB direction	PBDIR	00Ch
	Port PB output	PBOUT	00Ah
	Port PB input	PBIN	008h

Table 6-10. Peripherals With Byte Access

MODULE	REGISTER NAME	ACRONYM	ADDRESS
OA2	Operational Amplifier 2 control register 1	OA2CTL1	0C5h
	Operational Amplifier 2 control register 0	OA2CTL0	0C4h
OA1	Operational Amplifier 1 control register 1	OA1CTL1	0C3h
	Operational Amplifier 1 control register 0	OA1CTL0	0C2h
OA0	Operational Amplifier 0 control register 1	OA0CTL1	0C1h
	Operational Amplifier 0 control register 0	OA0CTL0	0C0h
LCD_A	LCD Voltage Control 1	LCDVAVCTL1	0AFh
	LCD Voltage Control 0	LCDVAVCTL0	0AEh
	LCD Voltage Port Control 1	LCDVAPCTL1	0ADh
	LCD Voltage Port Control 0	LCDVAPCTL0	0ACh
	LCD memory 20	LCDM20	0A4h
	:	:	:
	LCD memory 16	LCDM16	0A0h
	LCD memory 15	LCDM15	09Fh
	:	:	:
	LCD memory 1	LCDM1	091h
	LCD control and mode	LCDCTL	090h
ADC12 (Memory control registers require byte access)	ADC memory-control register 15	ADC12MCTL15	08Fh
	ADC memory-control register 14	ADC12MCTL14	08Eh
	ADC memory-control register 13	ADC12MCTL13	08Dh
	ADC memory-control register 12	ADC12MCTL12	08Ch
	ADC memory-control register 11	ADC12MCTL11	08Bh
	ADC memory-control register 10	ADC12MCTL10	08Ah
	ADC memory-control register 9	ADC12MCTL9	089h
	ADC memory-control register 8	ADC12MCTL8	088h
	ADC memory-control register 7	ADC12MCTL7	087h
	ADC memory-control register 6	ADC12MCTL6	086h
	ADC memory-control register 5	ADC12MCTL5	085h
	ADC memory-control register 4	ADC12MCTL4	084h
	ADC memory-control register 3	ADC12MCTL3	083h
	ADC memory-control register 2	ADC12MCTL2	082h
	ADC memory-control register 1	ADC12MCTL1	081h
ADC memory-control register 0	ADC12MCTL0	080h	
USART1	Transmit buffer	U1TXBUF	07Fh
	Receive buffer	U1RXBUF	07Eh
	Baud rate	U1BR1	07Dh
	Baud rate	U1BR0	07Ch
	Modulation control	U1MCTL	07Bh
	Receive control	U1RCTL	07Ah
	Transmit control	U1TCTL	079h
	USART control	U1CTL	078h
USCI	USCI I2C Slave Address	UCBI2CSA	011Ah
	USCI I2C Own Address	UCBI2COA	0118h
	USCI Synchronous Transmit Buffer	UCBTXBUF	06Fh
	USCI Synchronous Receive Buffer	UCBRXBUF	06Eh
	USCI Synchronous Status	UCBSTAT	06Dh
	USCI I2C Interrupt Enable	UCBI2CIE	06Ch
	USCI Synchronous Bit Rate 1	UCBBR1	06Bh
	USCI Synchronous Bit Rate 0	UCBBR0	06Ah
	USCI Synchronous Control 1	UCBCTL1	069h
	USCI Synchronous Control 0	UCBCTL0	068h
	USCI Transmit Buffer	UCATXBUF	067h
	USCI Receive Buffer	UCARXBUF	066h
	USCI Status	UCASTAT	065h
	USCI Modulation Control	UCAMCTL	064h
	USCI Baud Rate 1	UCABR1	063h
	USCI Baud Rate 0	UCABR0	062h
	USCI Control 1	UCACTL1	061h
	USCI Control 0	UCACTL0	060h
	USCI IrDA Receive Control	UCAIRRCTL	05Fh
	USCI IrDA Transmit Control	UCAIRTCTL	05Eh
USCI LIN Control	UCAABCTL	05Dh	
Comparator_A	Comparator_A port disable	CAPD	05Bh
	Comparator_A control 2	CACTL2	05Ah
	Comparator_A control 1	CACTL1	059h

Table 6-10. Peripherals With Byte Access (continued)

MODULE	REGISTER NAME	ACRONYM	ADDRESS
BrownOUT, SVS	SVS control register (Reset by brownout signal)	SVSCTL	056h
FLL+Clock	FLL+ Control 1 FLL+ Control 0 System clock frequency control System clock frequency integrator System clock frequency integrator	FLL_CTL1 FLL_CTL0 SCFQCTL SCFI1 SCFI0	054h 053h 052h 051h 050h
RTC (Basic Timer 1)	Real Time Clock Year High Byte Real Time Clock Year Low Byte Real Time Clock Month Real Time Clock Day of Month Basic Timer1 Counter 2 Basic Timer1 Counter 1 Real Time Counter 4 (Real Time Clock Day of Week) Real Time Counter 3 (Real Time Clock Hour) Real Time Counter 2 (Real Time Clock Minute) Real Time Counter 1 (Real Time Clock Second) Real Time Clock Control Basic Timer1 Control	RTCYEARH RTCYEARL RTCMON RTCDAV BTCNT2 BTCNT1 RTCNT4 (RTCDOW) RTCNT3 (RTCHOUR) RTCNT2 (RTCMIN) RTCNT1 (RTCSEC) RTCCTL BTCTL	04Fh 04Eh 04Dh 04Ch 047h 046h 045h 044h 043h 042h 041h 040h
Port P10	Port P10 selection Port P10 direction Port P10 output Port P10 input	P10SEL P10DIR P10OUT P10IN	00Fh 00Dh 00Bh 009h
Port P9	Port P9 selection Port P9 direction Port P9 output Port P9 input	P9SEL P9DIR P9OUT P9IN	00Eh 00Ch 00Ah 008h
Port P8	Port P8 selection Port P8 direction Port P8 output Port P8 input	P8SEL P8DIR P8OUT P8IN	03Fh 03Dh 03Bh 039h
Port P7	Port P7 selection Port P7 direction Port P7 output Port P7 input	P7SEL P7DIR P7OUT P7IN	03Eh 03Ch 03Ah 038h
Port P6	Port P6 selection Port P6 direction Port P6 output Port P6 input	P6SEL P6DIR P6OUT P6IN	037h 036h 035h 034h
Port P5	Port P5 selection Port P5 direction Port P5 output Port P5 input	P5SEL P5DIR P5OUT P5IN	033h 032h 031h 030h
Port P4	Port P4 selection Port P4 direction Port P4 output Port P4 input	P4SEL P4DIR P4OUT P4IN	01Fh 01Eh 01Dh 01Ch
Port P3	Port P3 selection Port P3 direction Port P3 output Port P3 input	P3SEL P3DIR P3OUT P3IN	01Bh 01Ah 019h 018h
Port P2	Port P2 selection Port P2 interrupt enable Port P2 interrupt-edge select Port P2 interrupt flag Port P2 direction Port P2 output Port P2 input	P2SEL P2IE P2IES P2IFG P2DIR P2OUT P2IN	02Eh 02Dh 02Ch 02Bh 02Ah 029h 028h

Table 6-10. Peripherals With Byte Access (continued)

MODULE	REGISTER NAME	ACRONYM	ADDRESS
Port P1	Port P1 selection	P1SEL	026h
	Port P1 interrupt enable	P1IE	025h
	Port P1 interrupt-edge select	P1IES	024h
	Port P1 interrupt flag	P1IFG	023h
	Port P1 direction	P1DIR	022h
	Port P1 output	P1OUT	021h
	Port P1 input	P1IN	020h
Special functions	SFR module enable 2	ME2	005h
	SFR module enable 1	ME1	004h
	SFR interrupt flag 2	IFG2	003h
	SFR interrupt flag 1	IFG1	002h
	SFR interrupt enable 2	IE2	001h
	SFR interrupt enable 1	IE1	000h

6.10 Input/Output Schematics

6.10.1 Port P1, P1.0 to P1.5, Input/Output With Schmitt Trigger

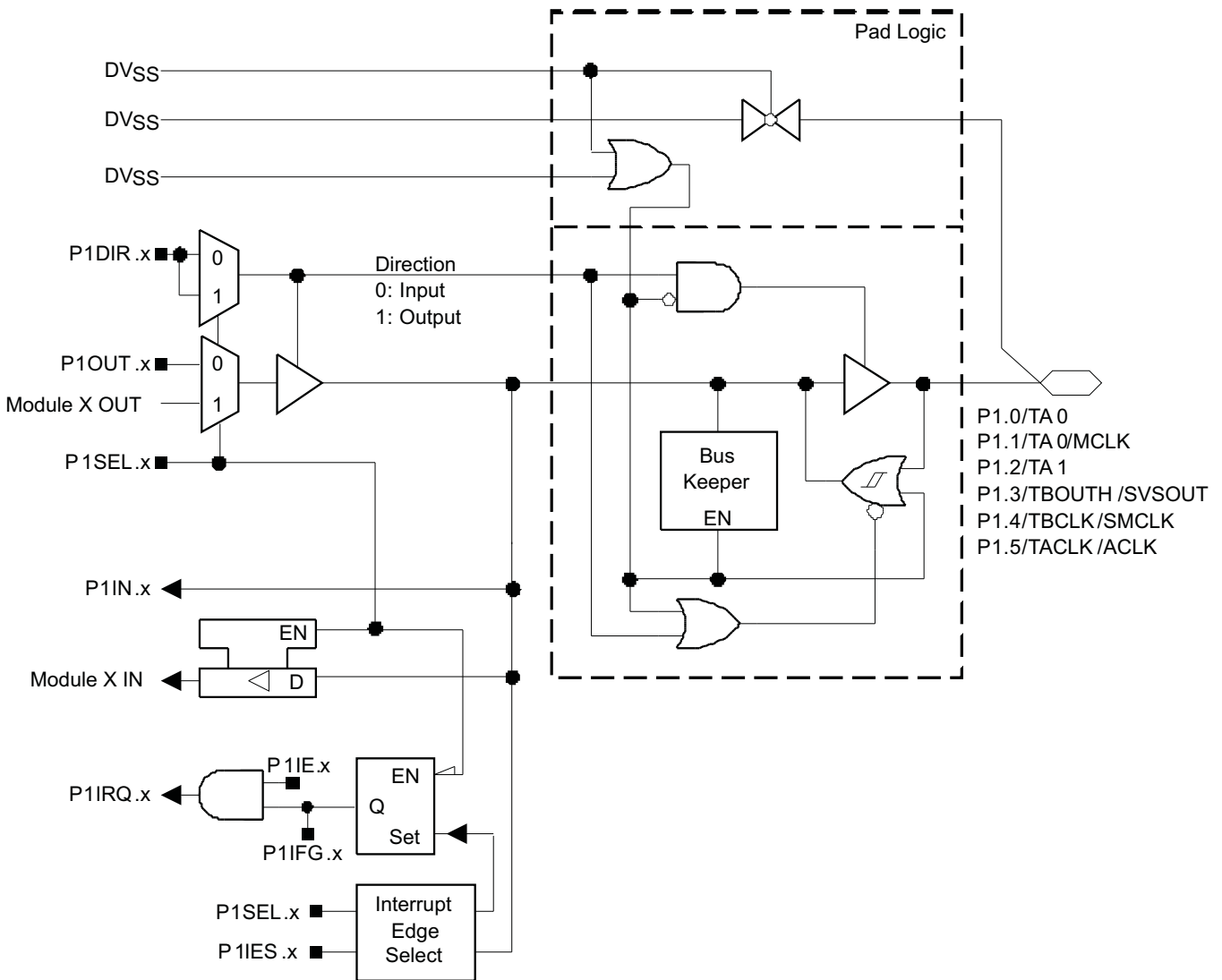

Note : x = 0,1,2,3,4,5

Table 6-11. Port P1 (P1.0 to P1.5) Pin Functions

PIN NAME (P1.x)	x	FUNCTION	CONTROL BITS OR SIGNALS	
			P1DIR.x	P1SEL.x
P1.0/TA0	0	P1.0 (I/O)	I: 0; O: 1	0
		Timer_A3.CCI0A	0	1
		Timer_A3.TA0	1	1
P1.1/TA0/MCLK	1	P1.1 (I/O)	I: 0; O: 1	0
		Timer_A3.CCI0B	0	1
		MCLK	1	1
P1.2/TA1	2	P1.2 (I/O)	I: 0; O: 1	0
		Timer_A3.CCI1A	0	1
		Timer_A3.TA1	1	1
P1.3/TBOUTH/SVSOUT	3	P1.3 (I/O)	I: 0; O: 1	0
		Timer_B7.TBOUTH	0	1
		SVSOUT	1	1
P1.4/TBCLK/SMCLK	4	P1.4 (I/O)	I: 0; O: 1	0
		Timer_B7.TBCLK	0	1
		SMCLK	1	1
P1.5/TACLK/ACLK	5	P1.5 (I/O)	I: 0; O: 1	0
		Timer_A3.TACLK	0	1
		ACLK	1	1

6.10.2 Port P1, P1.6, P1.7, Input/Output With Schmitt Trigger

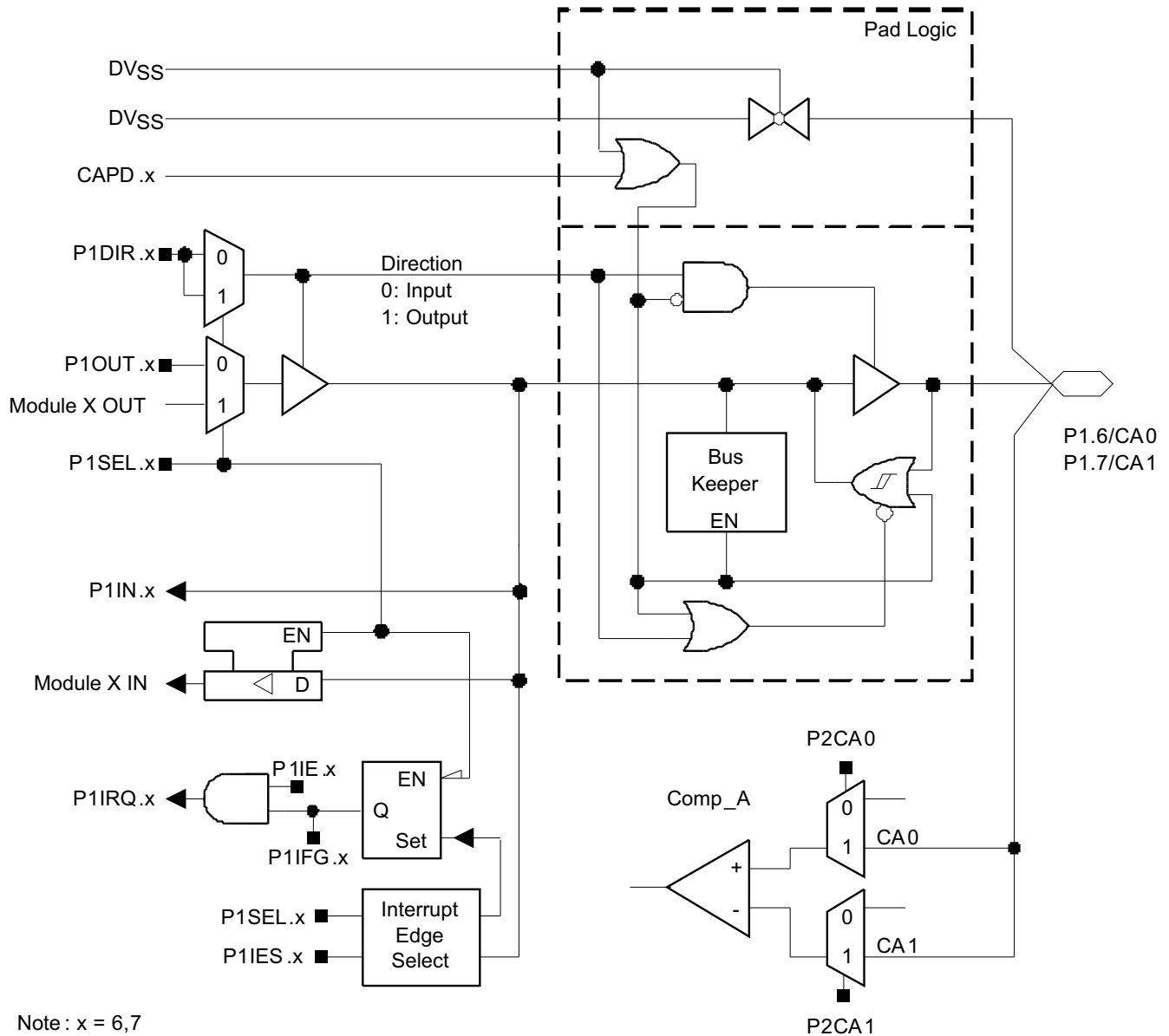

Note : x = 6,7

Table 6-12. Port P1 (P1.6 and P1.7) Pin Functions

PIN NAME (P1.x)	x	FUNCTION	CONTROL BITS OR SIGNALS ⁽¹⁾		
			CAPD.x	P1DIR.x	P1SEL.x
P1.6/CA0	6	P1.6 (I/O)	0	I: 0; O: 1	0
		CA0	1	X	X
P1.7/CA1	7	P1.7 (I/O)	0	I: 0; O: 1	0
		CA1	1	X	X

(1) X = don't care

6.10.3 Port P2, P2.0 to P2.3, P2.6 to P2.7, Input/Output With Schmitt Trigger

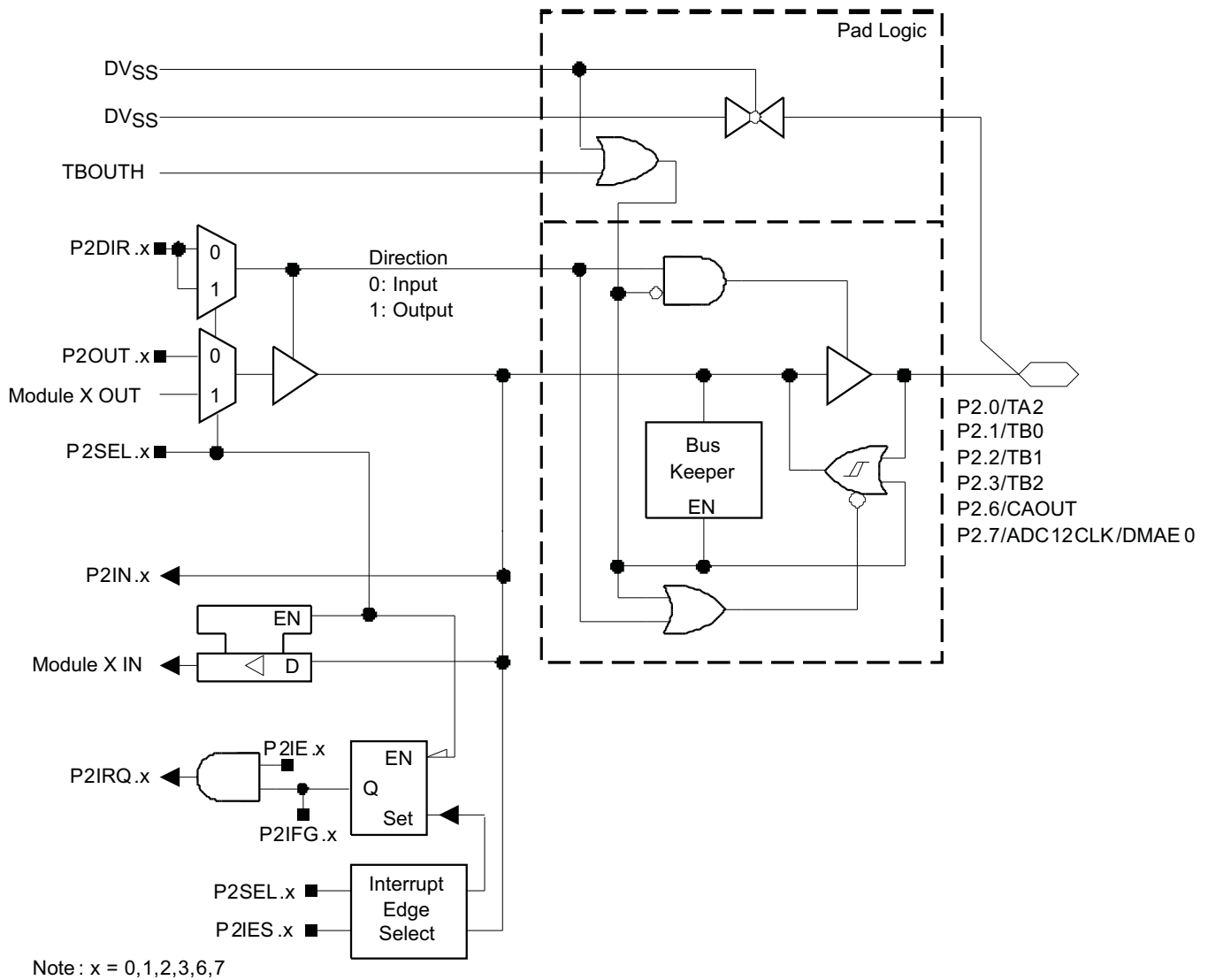
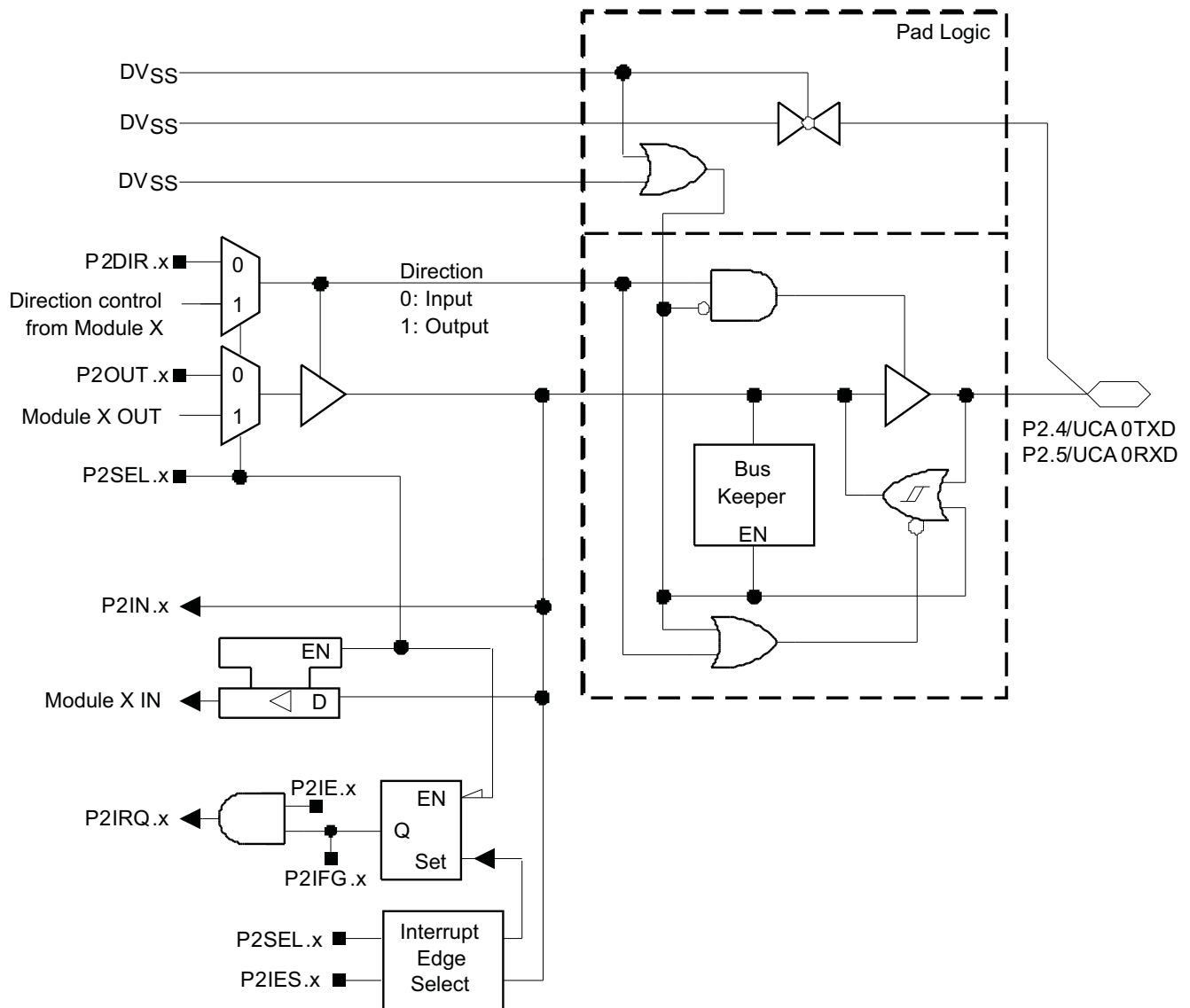

Table 6-13. Port P2 (P2.0, P2.1, P2.2, P2.3, P2.6 and P2.7) Pin Functions

PIN NAME (P2.x)	x	FUNCTION	CONTROL BITS OR SIGNALS	
			P2DIR.x	P2SEL.x
P2.0/TA2	0	P2.0 (I/O)	I: 0; O: 1	0
		Timer_A3.CCI2A	0	1
		Timer_A3.TA2	1	1
P2.1/TB0	1	P2.1 (I/O)	I: 0; O: 1	0
		Timer_B7.CCI0A and Timer_B7.CCI0B	0	1
		Timer_B7.TB0 ⁽¹⁾	1	1
P2.2/TB1	2	P2.2 (I/O)	I: 0; O: 1	0
		Timer_B7.CCI1A and Timer_B7.CCI1B	0	1
		Timer_B7.TB1 ⁽¹⁾	1	1
P2.3/TB3	3	P2.3 (I/O)	I: 0; O: 1	0
		Timer_B7.CCI2A and Timer_B7.CCI2B	0	1
		Timer_B7.TB3 ⁽¹⁾	1	1
P2.6/CAOUT	6	P2.6 (I/O)	I: 0; O: 1	0
		CAOUT	1	1
P2.7/ADC12CLK/DMAE0	7	P2.7 (I/O)	I: 0; O: 1	0
		ADC12CLK	1	1
		DMAE0	0	1

(1) Setting TBOUTH causes all Timer_B outputs to be set to high impedance.

6.10.4 Port P2, P2.4 to P2.5, Input/Output With Schmitt Trigger



Note: x = 4,5

Table 6-14. Port P2 (P2.4 and P2.5) Pin Functions

PIN NAME (P2.x)	x	FUNCTION	CONTROL BITS OR SIGNALS ⁽¹⁾	
			P2DIR.x	P2SEL.x
P2.4/UCA0TXD	4	P2.4 (I/O)	I: 0; O: 1	0
		USCI_A0.UCA0TXD ⁽²⁾	X	1
P2.5/UCA0RXD	5	P2.5 (I/O)	I: 0; O: 1	0
		USCI_A0.UCA0RXD ⁽²⁾	X	1

(1) X = don't care

(2) When in USCI mode, P2.4 is set to output, P2.5 is set to input.

6.10.5 Port P3, P3.0 to P3.3, Input/Output With Schmitt Trigger

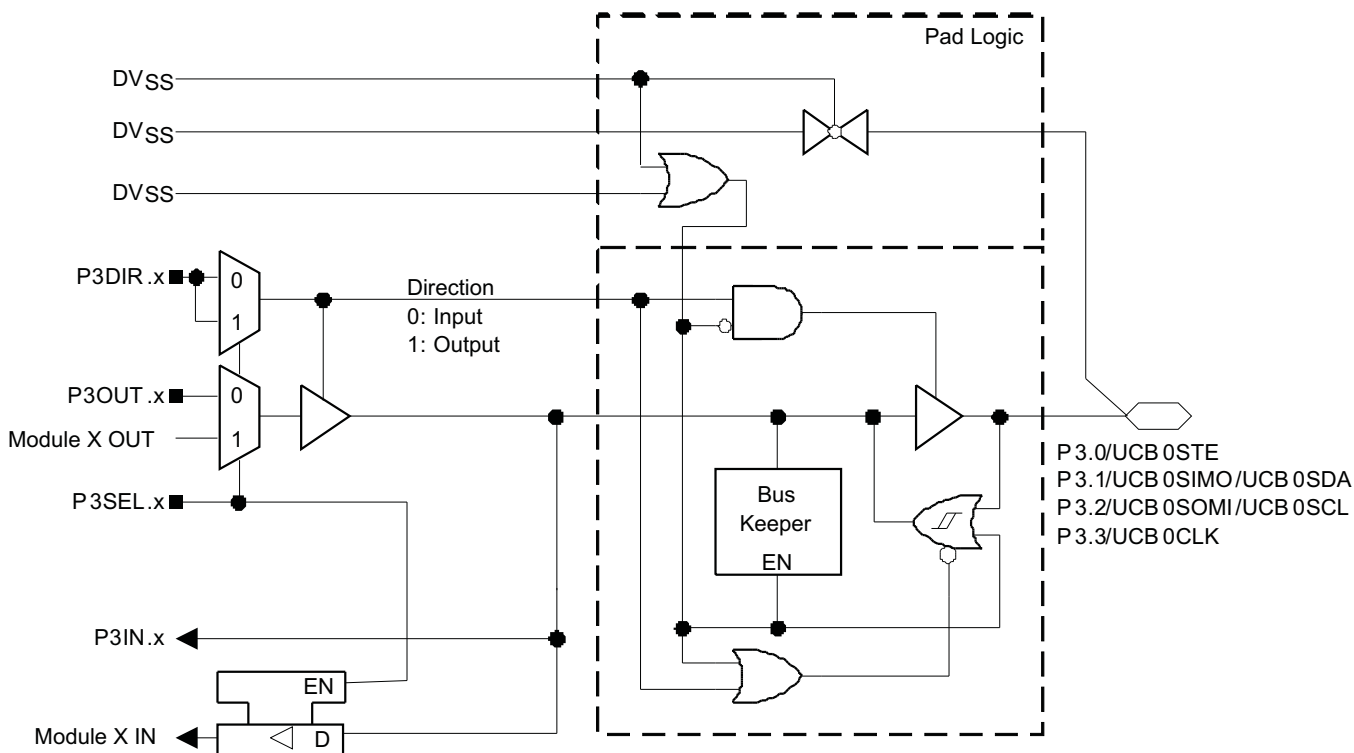

Note: x = 0,1,2,3

Table 6-15. Port P3 (P3.0 to P3.3) Pin Functions

PIN NAME (P3.x)	x	FUNCTION	CONTROL BITS OR SIGNALS ⁽¹⁾	
			P3DIR.x	P3SEL.x
P3.0/UCB0STE	0	P3.0 (I/O)	I: 0; O: 1	0
		UCB0STE ⁽²⁾	X	1
P3.1/UCB0SIMO/UCB0SDA	1	P3.1 (I/O)	I: 0; O: 1	0
		UCB0SIMO/UCB0SDA ^{(2) (3)}	X	1
P3.2/UCB0SOMI/UCB0SCL	2	P3.2 (I/O)	I: 0; O: 1	0
		UCB0SOMI/UCB0SCL ^{(2) (3)}	X	1
P3.3/UCB0CLK	3	P3.3 (I/O)	I: 0; O: 1	0
		UCB0CLK ⁽²⁾	X	1

- (1) X = don't care
- (2) The pin direction is controlled by the USCI module.
- (3) If the I²C functionality is selected the output drives only the logical 0 to V_{SS} level.

6.10.6 Port P3, P3.4 to P3.7, Input/Output With Schmitt Trigger

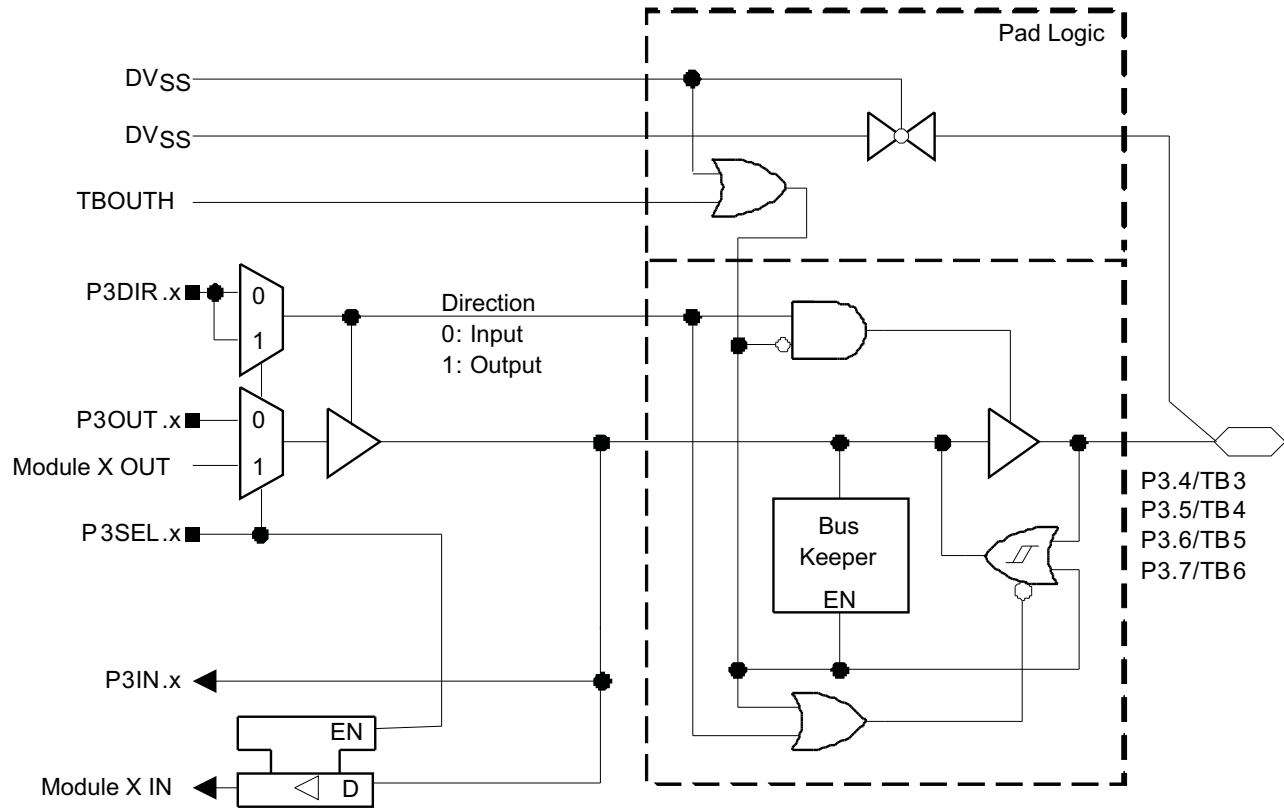

Note: x = 4,5,6,7

Table 6-16. Port P3 (P3.4 to P3.7) Pin Functions

PIN NAME (P3.x)	x	FUNCTION	CONTROL BITS OR SIGNALS	
			P3DIR.x	P3SEL.x
P3.4/TB3	4	P3.4 (I/O)	I: 0; O: 1	0
		Timer_B7.CCI3A and Timer_B7.CCI3B	0	1
		Timer_B7.TB3 ⁽¹⁾	1	1
P3.5/TB4	5	P3.5 (I/O)	I: 0; O: 1	0
		Timer_B7.CCI4A and Timer_B7.CCI4B	0	1
		Timer_B7.TB4 ⁽¹⁾	1	1
P3.6/TB5	6	P3.6 (I/O)	I: 0; O: 1	0
		Timer_B7.CCI5A and Timer_B7.CCI5B	0	1
		Timer_B7.TB5 ⁽¹⁾	1	1
P3.7/TB6	7	P3.7 (I/O)	I: 0; O: 1	0
		Timer_B7.CCI6A and Timer_B7.CCI6B	0	1
		Timer_B7.TB6 ⁽¹⁾	1	1

(1) Setting TBOUTH causes all Timer_B outputs to be set to high impedance.

6.10.7 Port P4, P4.0 to P4.1, Input/Output With Schmitt Trigger

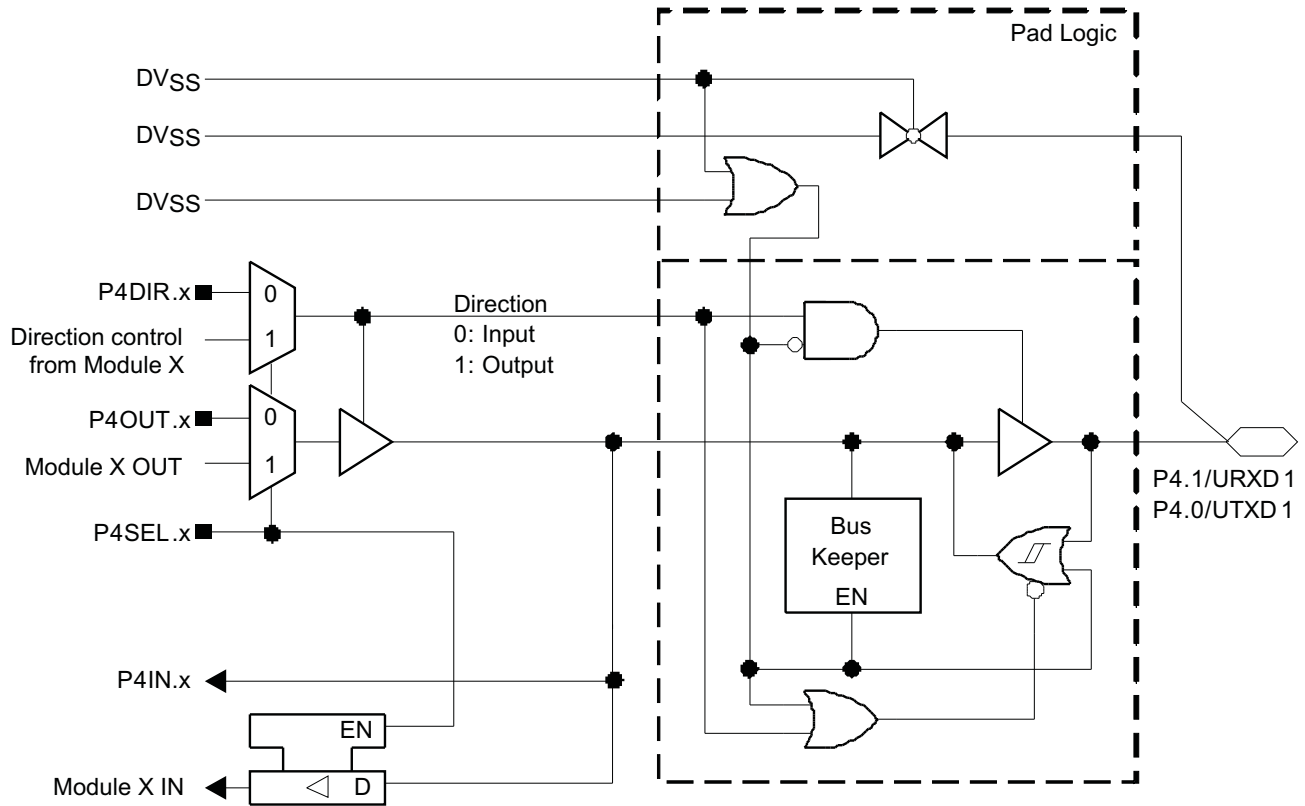

Note: x = 0,1

Table 6-17. Port P4 (P4.0 to P4.1) Pin Functions

PIN NAME (P4.x)	x	FUNCTION	CONTROL BITS OR SIGNALS ⁽¹⁾	
			P4DIR.x	P4SEL.x
P4.0/UTXD1	0	P4.0 (I/O)	I: 0; O: 1	0
		USART1.UTXD1 ⁽²⁾	X	1
P4.1/URXD1	1	P4.1 (I/O)	I: 0; O: 1	0
		USART1.URXD1 ⁽²⁾	X	1

(1) X = don't care

(2) When in USART1 mode, P4.0 is set to output, P4.1 is set to input.

6.10.8 Port P4, P4.2 to P4.7, Input/Output With Schmitt Trigger

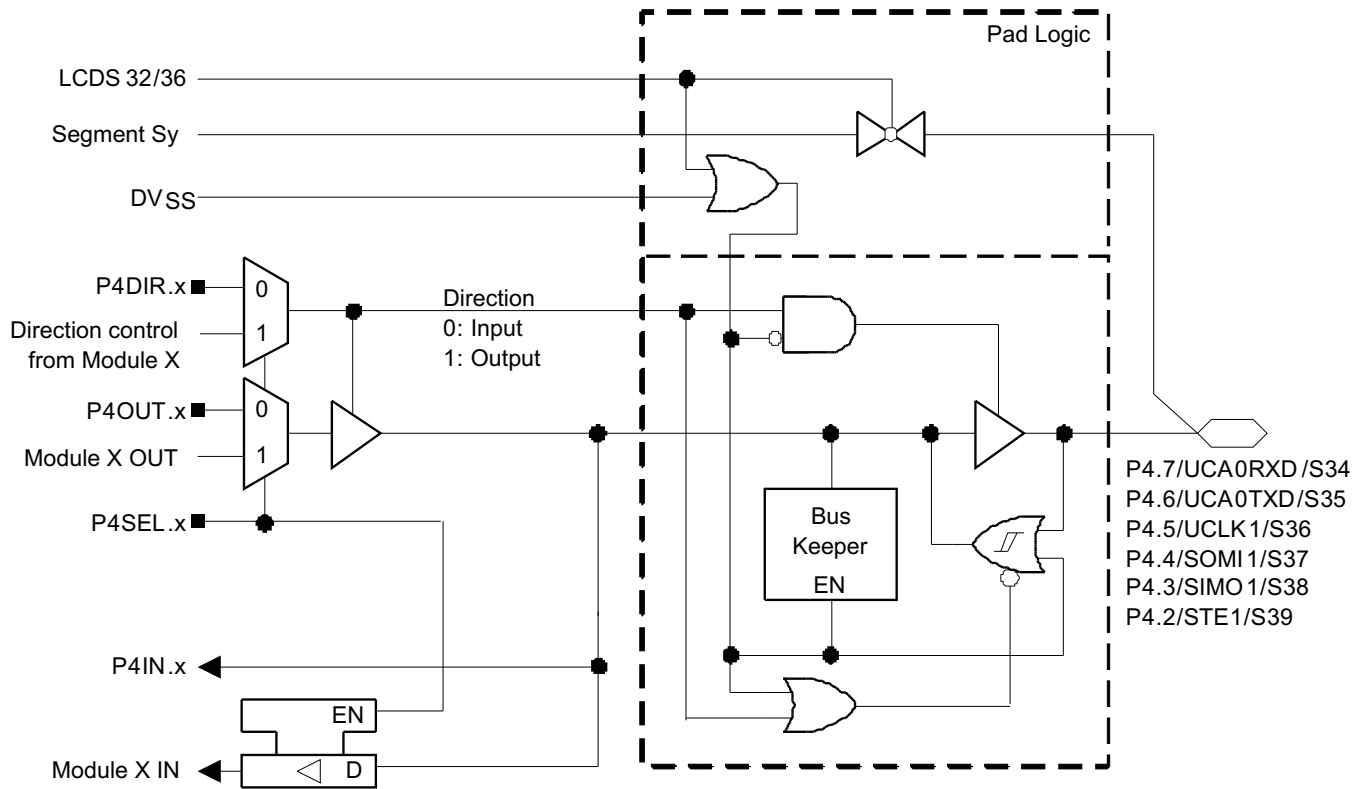

Note : x = 2,3,4,5,6,7
y = 34,35,36,37,38,39

Table 6-18. Port P4 (P4.2 to P4.5) Pin Functions

PIN NAME (P4.x)	x	FUNCTION	CONTROL BITS OR SIGNALS ⁽¹⁾		
			P4DIR.x	P4SEL.x	LCDS36
P4.2/STE1/S39	2	P4.2 (I/O)	I: 0; O: 1	0	0
		USART1.STE1	X	1	0
		S39	X	X	1
P4.3/SIMO/S38	3	P4.3 (I/O)	I: 0; O: 1	0	0
		USART1.SIMO1 ⁽²⁾	X	1	0
		S38	X	X	1
P4.4/SOMI/S37	4	P4.4 (I/O)	I: 0; O: 1	0	0
		USART1.SOMI1 ⁽²⁾	X	1	0
		S37	X	X	1
P4.5/SOMI/S36	5	P4.5 (I/O)	I: 0; O: 1	0	0
		USART1.UCLK1 ⁽²⁾	X	1	0
		S36	X	X	1

(1) X = don't care

(2) The pin direction is controlled by the USART1 module.

Table 6-19. Port P4 (P4.6 and P4.7) Pin Functions

PIN NAME (P4.x)	x	FUNCTION	CONTROL BITS OR SIGNALS ⁽¹⁾		
			P4DIR.x	P4SEL.x	LCDS32
P4.6/UCA0TXD/S35	6	P4.6 (I/O)	I: 0; O: 1	0	0
		USCI_A0.UCA0TXD ⁽²⁾	X	1	0
		S35	X	X	1
P4.7/UCA0RXD/S34	7	P4.7 (I/O)	I: 0; O: 1	0	0
		USCI_A0.UCA0RXD ⁽²⁾	X	1	0
		S34	X	X	1

(1) X = don't care

(2) When in USCI mode, P4.6 is set to output, P4.7 is set to input.

6.10.9 Port P5, P5.0, Input/Output With Schmitt Trigger

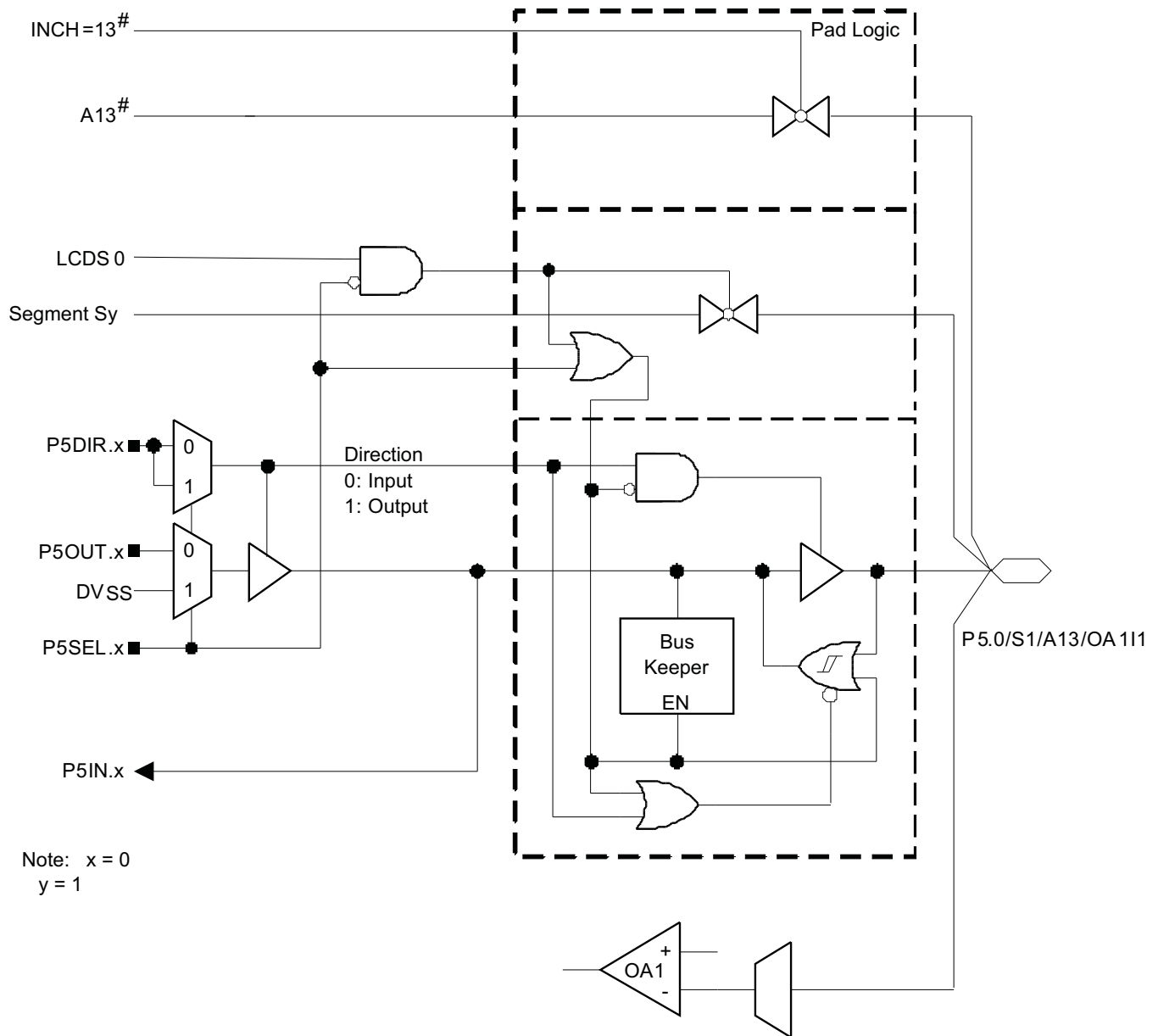

Table 6-20. Port P5 (P5.0) Pin Functions

PIN NAME (P5.x)	x	FUNCTION	CONTROL BITS OR SIGNALS ⁽¹⁾				
			P5DIR.x	P5SEL.x	INCHx	OAPx (OA1) OANx (OA1)	LCDS0
P5.0/S1/A13/OA111	0	P5.0 (I/O)	I: 0; O: 1	0	X	X	0
		OAI11	0	X	X	1	0
		A13 ⁽²⁾	X	1	13	X	X
		S1 enabled	X	0	X	X	1
		S1 disabled	X	1	X	X	1

(1) X = don't care

(2) Setting the P5SEL.x bit disables the output driver and the input Schmitt trigger to prevent parasitic cross currents when applying analog signals.

6.10.10 Port P5, P5.1, Input/Output With Schmitt Trigger

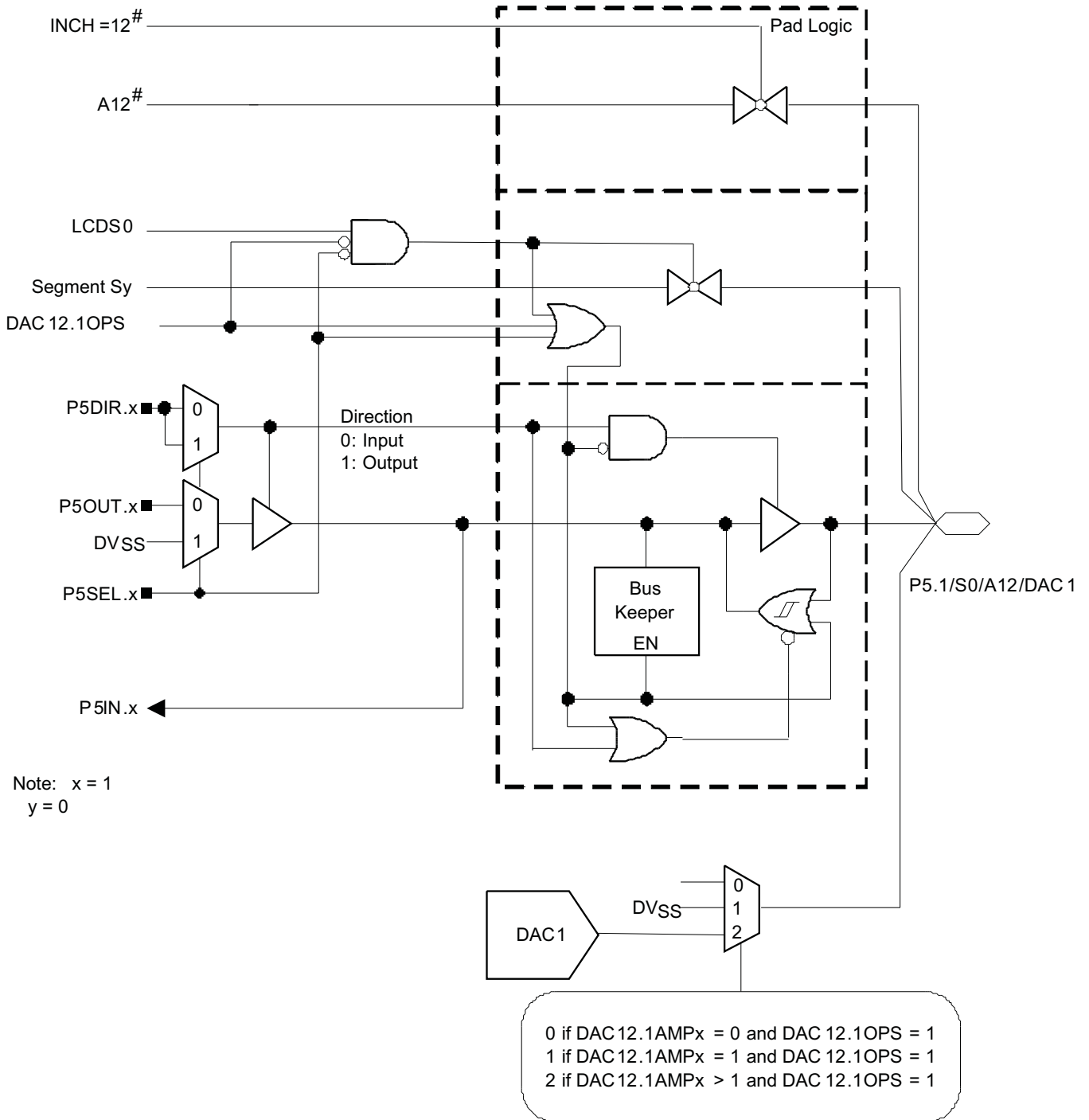

Table 6-21. Port P5 (P5.1) Pin Functions

PIN NAME (P5.x)	x	FUNCTION	CONTROL BITS OR SIGNALS ⁽¹⁾					
			P5DIR.x	P5SEL.x	INCHx	DAC12.1OPS	DAC12.1AMPx	LCDS0
P5.1/S0/A12/DAC1	1	P5.1 (I/O)	I: 0; O: 1	0	X	0	X	0
		DAC1 high impedance	X	X	X	1	0	X
		DVSS	X	X	X	1	1	X
		DAC1 output	X	X	X	1	>1	X
		A12 ⁽²⁾	X	1	12	0	X	0
		S0 enabled	X	0	X	0	X	1
		S0 disabled	X	1	X	0	X	1

(1) X = don't care

(2) Setting the P5SEL.x bit disables the output driver and the input Schmitt trigger to prevent parasitic cross currents when applying analog signals.

6.10.11 Port P5, P5.2 to P5.4, Input/Output With Schmitt Trigger

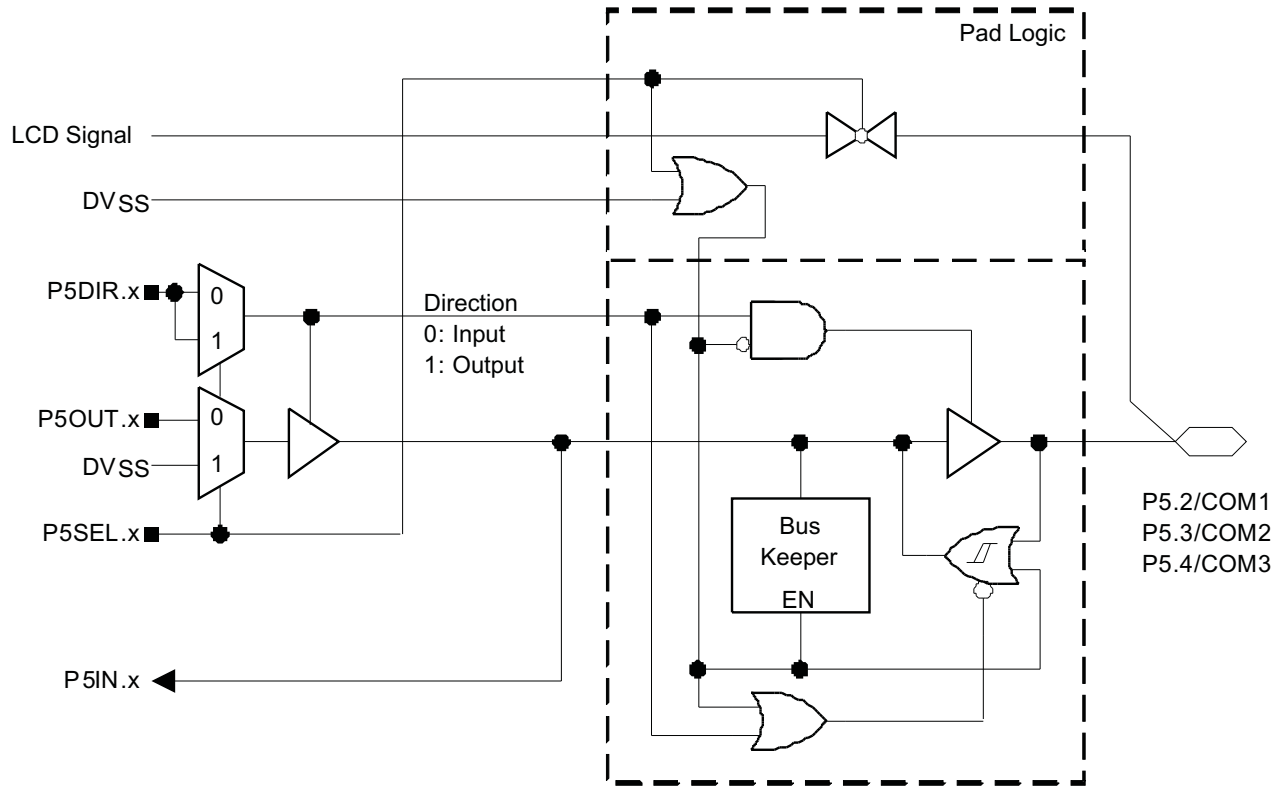

Note : x = 2,3,4

Table 6-22. Port P5 (P5.2 to P5.4) Pin Functions

PIN NAME (P5.x)	x	FUNCTION	CONTROL BITS OR SIGNALS ⁽¹⁾	
			P5DIR.x	P5SEL.x
P5.2/COM1	2	P5.2 (I/O)	I: 0; O: 1	0
		COM1	X	1
P5.3/COM2	3	P5.3 (I/O)	I: 0; O: 1	0
		COM2	X	1
P5.4/COM3	4	P5.4 (I/O)	I: 0; O: 1	0
		COM3	X	1

(1) X = don't care

6.10.12 Port P5, P5.5 to P5.7, Input/Output With Schmitt Trigger

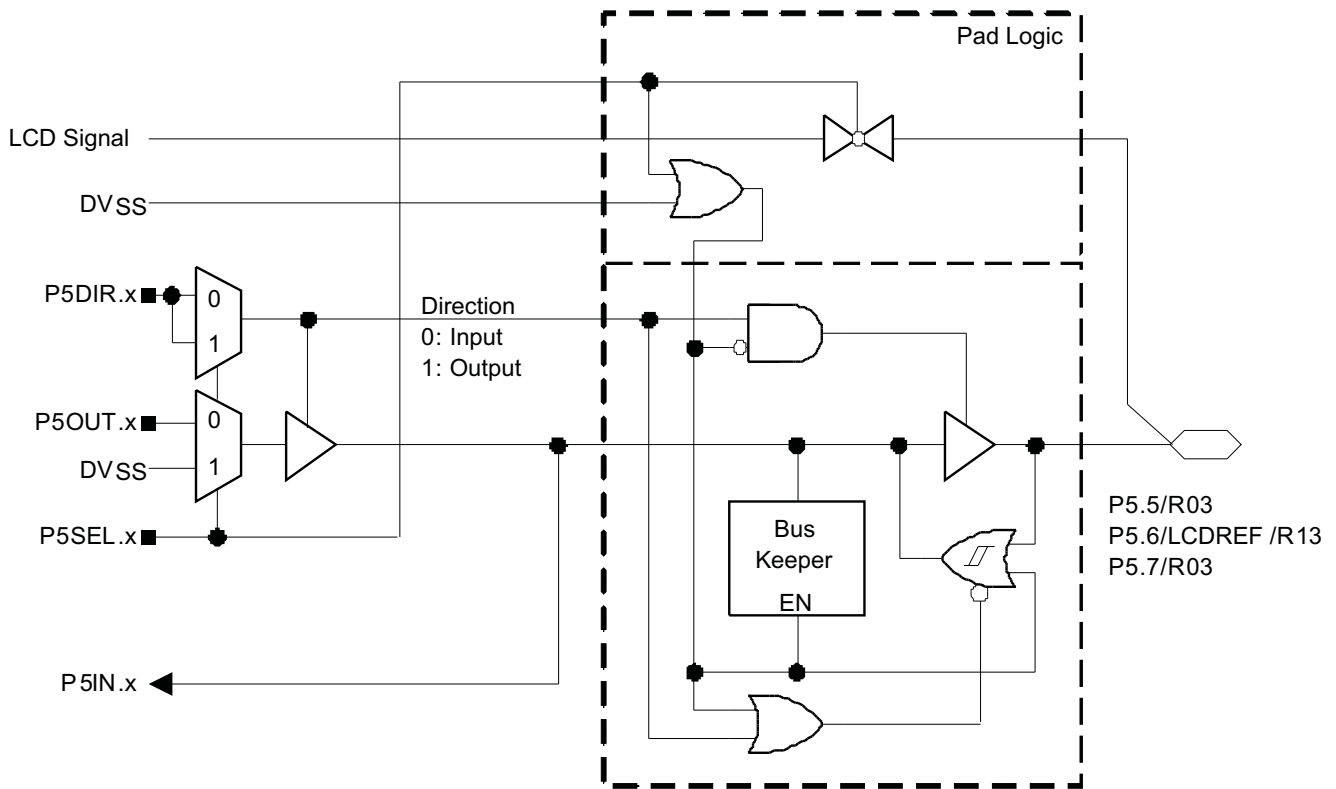

Note: x = 5,6,7

Table 6-23. Port P5 (P5.5 to P5.7) Pin Functions

PIN NAME (P5.x)	x	FUNCTION	CONTROL BITS OR SIGNALS ⁽¹⁾	
			P5DIR.x	P5SEL.x
P5.5/R03	5	P5.5 (I/O)	I: 0; O: 1	0
		R03	X	1
P5.6/LCDREF/R13	6	P5.6 (I/O)	I: 0; O: 1	0
		R13 or LCDREF ⁽²⁾	X	1
P5.7/R03	7	P5.7 (I/O)	I: 0; O: 1	0
		R03	X	1

(1) X = don't care

(2) External reference for the LCD_A charge pump is applied when VLCDREFx = 01. Otherwise R13 is selected.

6.10.13 Port P6, P6.0, P6.2, and P6.4, Input/Output With Schmitt Trigger

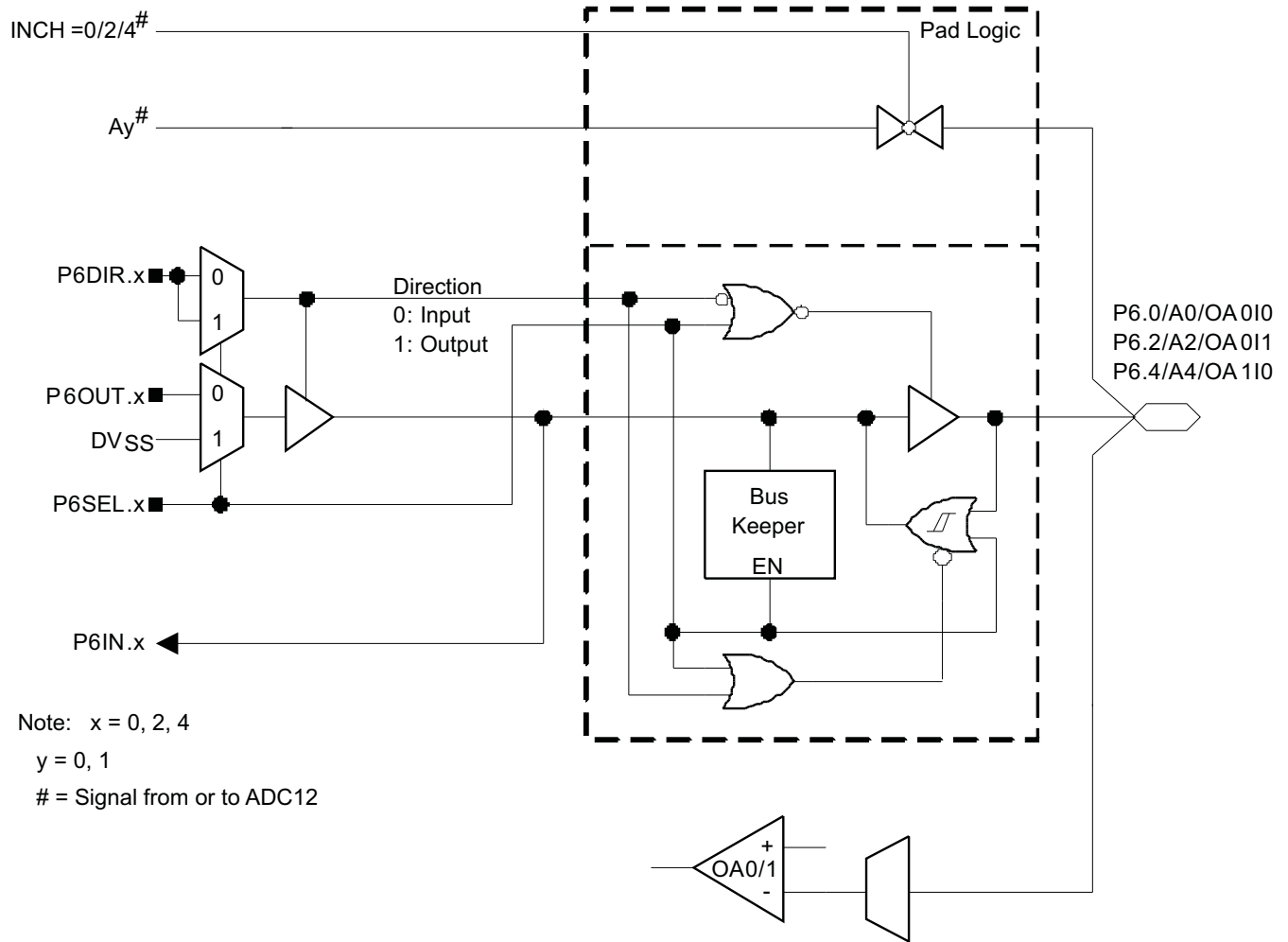

Table 6-24. Port P6 (P6.0, P6.2, and P6.4) Pin Functions

PIN NAME (P6.x)	x	FUNCTION	CONTROL BITS OR SIGNALS ⁽¹⁾				
			P6DIR.x	P6SEL.x	OAPx (OA0) OANx (OA0)	OAPx (OA1) OANx (OA1)	INCHx
P6.0/A0/OA0I0	0	P6.0 (I/O)	I: 0; O: 1	0	X	X	X
		OA0I0	0	X	0	X	X
		A0 ⁽²⁾	X	1	X	X	0
P6.2/A2/OA0I1	2	P6.2 (I/O)	I: 0; O: 1	0	X	X	X
		OA0I1	0	X	1	X	X
		A2 ⁽²⁾	X	1	X	X	2
P6.4/A4/OA1I0	4	P6.4 (I/O)	I: 0; O: 1	0	X	X	X
		OA1I0	0	X	X	0	X
		A4 ⁽²⁾	X	1	X	X	4

(1) X = don't care

(2) Setting the P6SEL.x bit disables the output driver and the input Schmitt trigger to prevent parasitic cross currents when applying analog signals.

6.10.14 Port P6, P6.1, P6.3, and P6.5 Input/Output With Schmitt Trigger

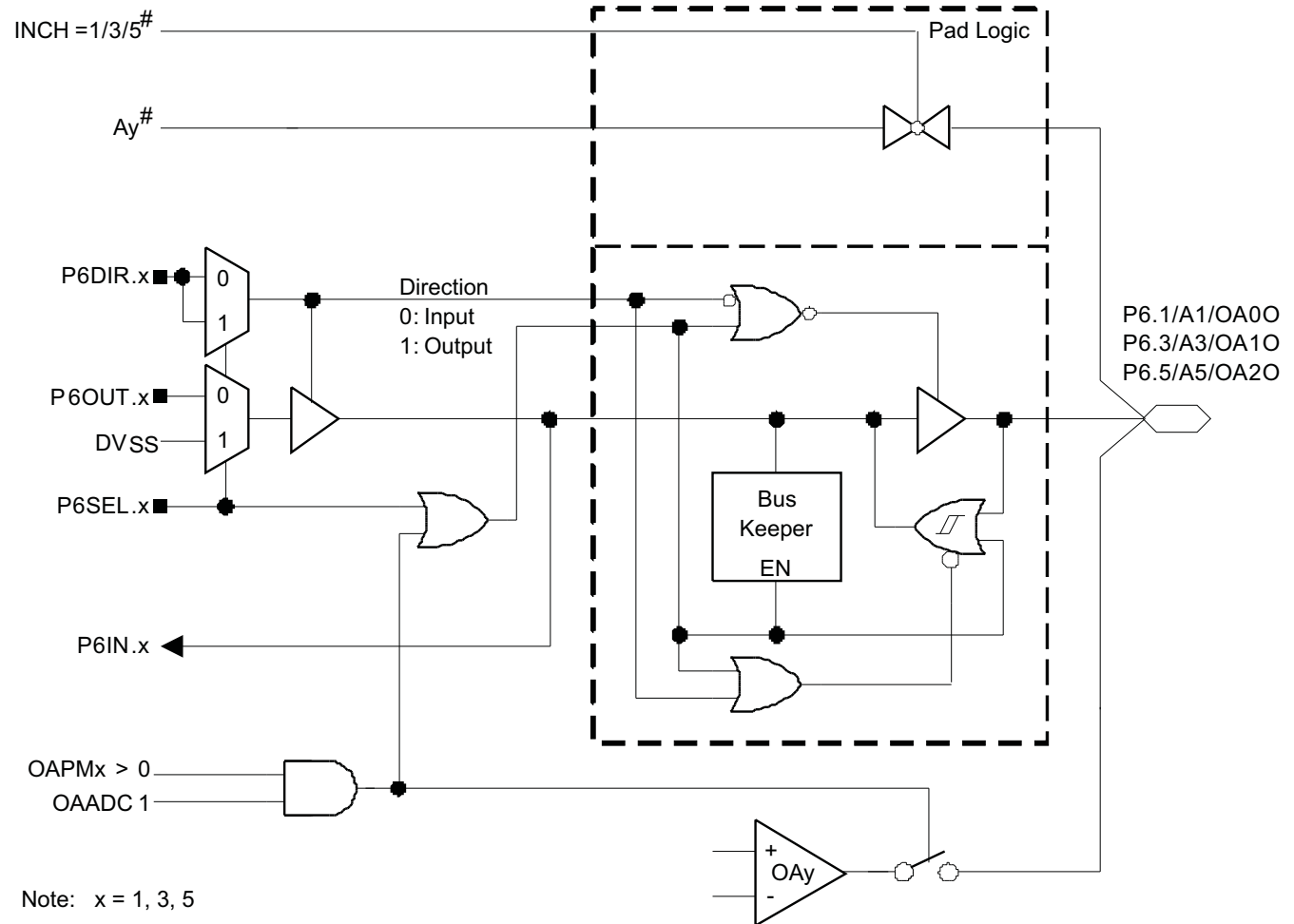

Note: x = 1, 3, 5
y = 0, 1, 2
= Signal from or to ADC12

Table 6-25. Port P6 (P6.1, P6.3, and P6.5) Pin Functions

PIN NAME (P6.x)	x	FUNCTION	CONTROL BITS OR SIGNALS ⁽¹⁾				
			P6DIR.x	P6SEL.x	OAADC1	OAPMx	INCHx
P6.1/A1/OA00	1	P6.1 (I/O)	I: 0; O: 1	0	X	0	X
		OA00 ⁽²⁾	X	X	1	>0	X
		A1 ⁽³⁾	X	1	X	0	1
P6.3/A3/OA10	3	P6.3 (I/O)	I: 0; O: 1	0	X	0	X
		OA10 ⁽²⁾	X	X	1	>0	X
		A3 ⁽³⁾	X	1	X	0	3
P6.5/A5/OA20	5	P6.5 (I/O)	I: 0; O: 1	0	X	0	X
		OA20 ⁽²⁾	X	X	1	>0	X
		A5 ⁽³⁾	X	1	X	0	5

- (1) X = don't care
- (2) Setting the OAADC1 bit or setting OAFcx = 00 will cause the operational amplifier to be present at the pin as well as internally connected to the corresponding ADC12 input.
- (3) Setting the P6SEL.x bit disables the output driver and the input Schmitt trigger to prevent parasitic cross currents when applying analog signals.

6.10.15 Port P6, P6.6, Input/Output With Schmitt Trigger

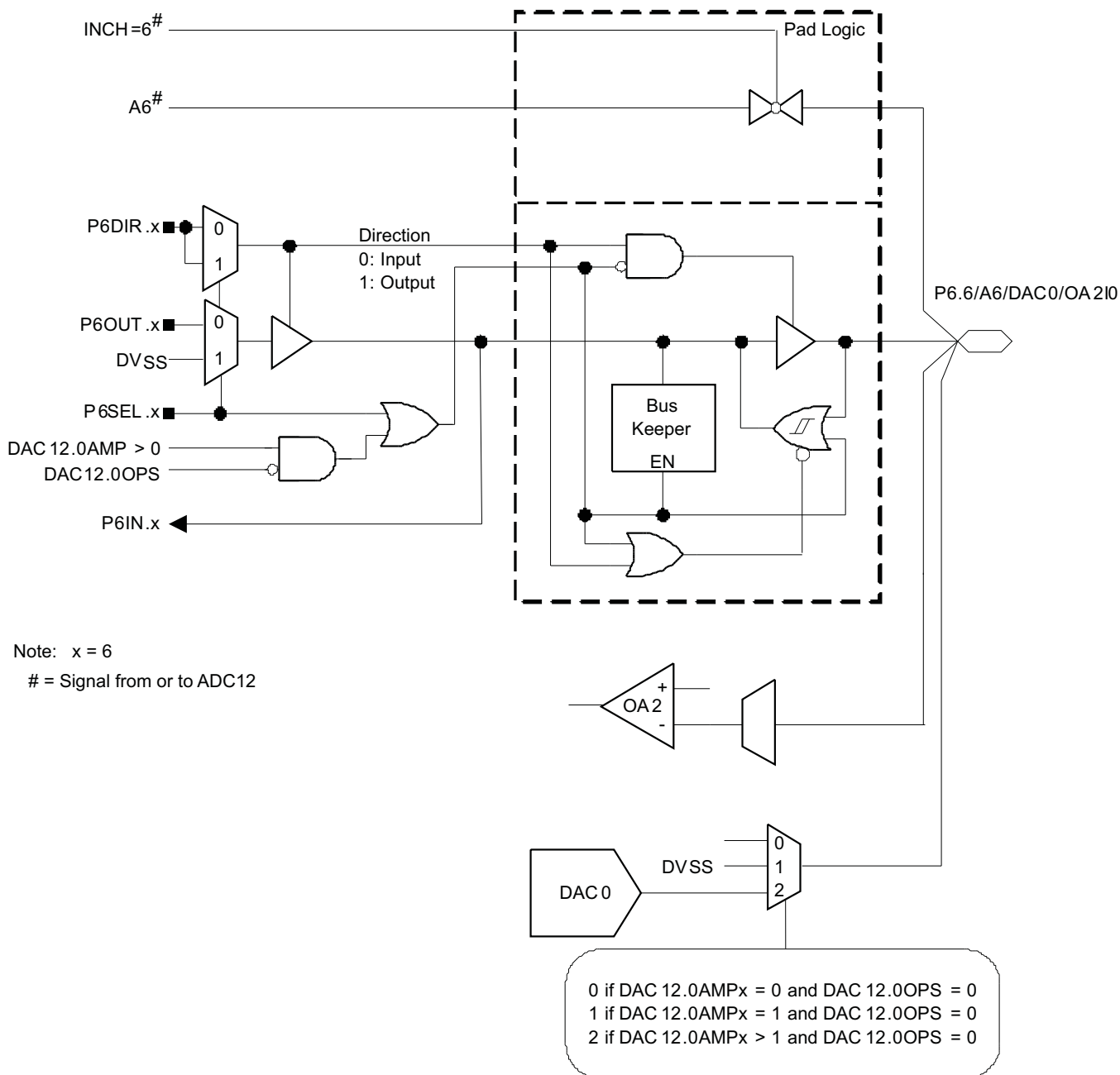

Table 6-26. Port P6 (P6.6) Pin Functions

PIN NAME (P6.x)	x	FUNCTION	CONTROL BITS OR SIGNALS ⁽¹⁾					
			P6DIR.x	P6SEL.x	INCHx	DAC12.0OPS	DAC12.0AMPx	OAPx (OA2) OANx (OA2)
P6.6/A6/DAC0/OA2I0	6	P6.6 (I/O)	I: 0; O: 1	0	X	1	X	X
		DAC0 high impedance	X	X	X	0	0	X
		DVSS	X	X	X	0	1	X
		DAC0 output	X	X	X	0	>1	X
		A6 ⁽²⁾	X	1	6	X	X	X
		OA2I0	0	X	0	X	X	0

(1) X = don't care

(2) Setting the P6SEL.x bit disables the output driver and the input Schmitt trigger to prevent parasitic cross currents when applying analog signals.

6.10.16 Port P6, P6.7, Input/Output With Schmitt Trigger

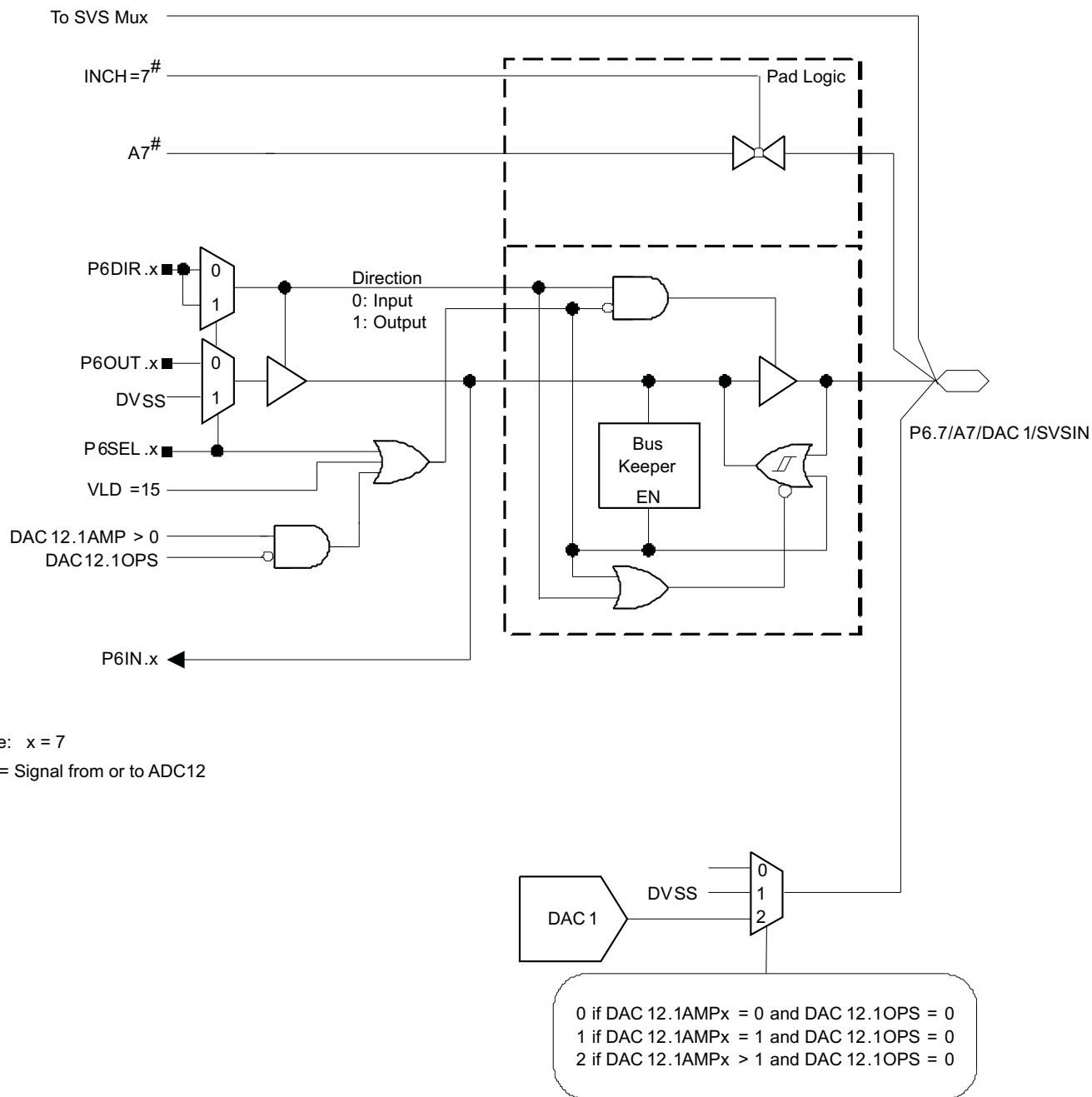

Table 6-27. Port P6 (P6.7) Pin Functions

PIN NAME (P6.x)	x	FUNCTION	CONTROL BITS OR SIGNALS ⁽¹⁾				
			P6DIR.x	P6SEL.x	INCHx	DAC12.1OPS	DAC12.1AMPx
P6.7/A7/DAC1/SVSIN	7	P6.7 (I/O)	I: 0; O: 1	0	X	1	X
		DAC1 high impedance	X	X	X	0	0
		DVSS	X	X	X	0	1
		DAC1 output	X	X	X	0	>1
		A7 ⁽²⁾	X	1	7	X	X
		SVSIN ⁽²⁾	0	1	0	1	X

(1) X = don't care

(2) Setting the P6SEL.x bit disables the output driver and the input Schmitt trigger to prevent parasitic cross currents when applying analog signals.

6.10.17 Port P7, P7.0 to P7.3, Input/Output With Schmitt Trigger

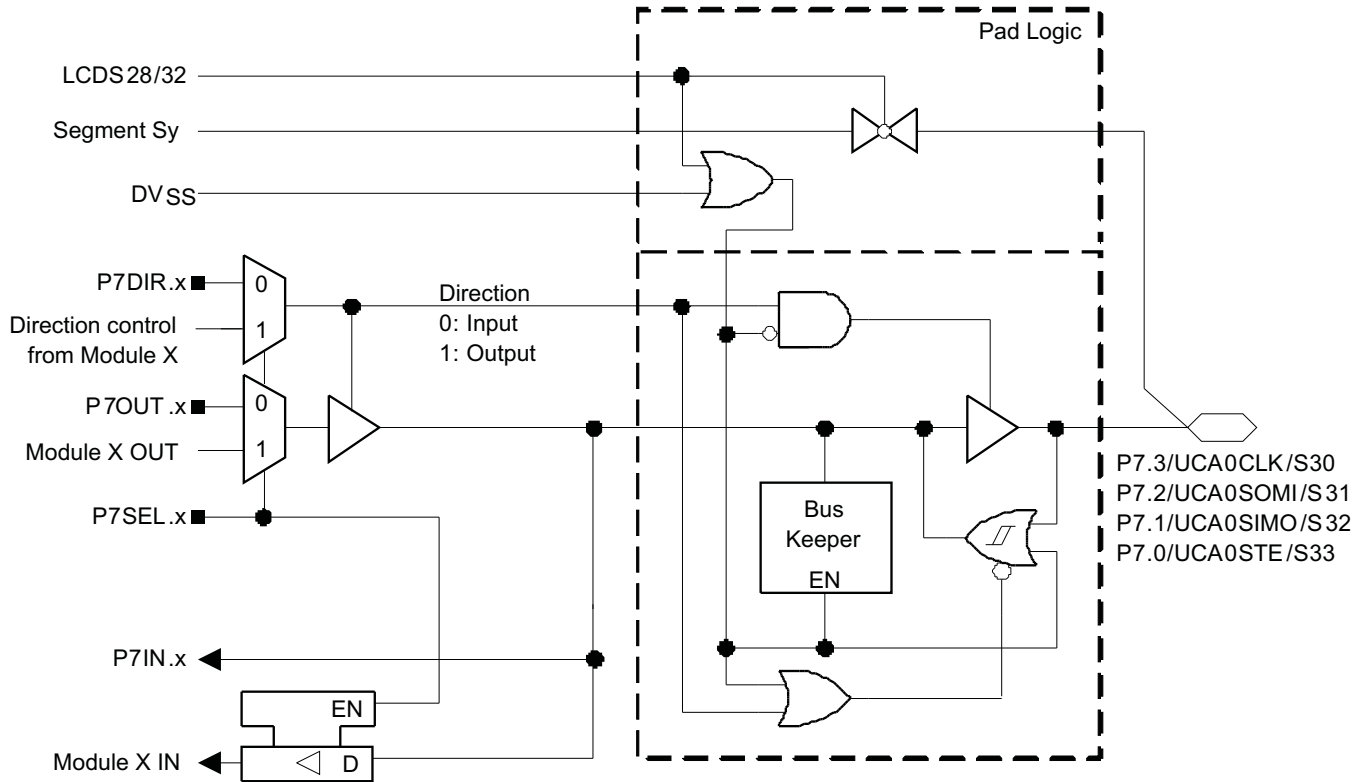

Note: x = 0, 1, 2, 3
y = 30, 31, 32, 33

Table 6-28. Port P7 (P7.0 and P7.1) Pin Functions

PIN NAME (P7.x)	x	FUNCTION	CONTROL BITS OR SIGNALS ⁽¹⁾		
			P7DIR.x	P7SEL.x	LCDS32
P7.0/UCA0STE/S33	0	P7.0 (I/O)	I: 0; O: 1	0	0
		USCI_A0.UCA0STE ⁽²⁾	X	1	0
		S33 ⁽¹⁾	X	X	1
P7.1/UCA0SIMO/S32	1	P7.1 (I/O)	I: 0; O: 1	0	0
		USCI_A0.UCA0SIMO ⁽²⁾	X	1	0
		S32	X	X	1

(1) X = don't care

(2) The pin direction is controlled by the USCI module.

Table 6-29. Port P7 (P7.2 and P7.3) Pin Functions

PIN NAME (P7.x)	x	FUNCTION	CONTROL BITS OR SIGNALS ⁽¹⁾		
			P7DIR.x	P7SEL.x	LCDS28
P7.2/UCA0SOMI/S31	2	P7.2 (I/O)	I: 0; O: 1	0	0
		USCI_A0.UCA0SOMI ⁽²⁾	X	1	0
		S31	X	X	1
P7.3/UCA0CLK/S30	3	P7.3 (I/O)	I: 0; O: 1	0	0
		USCI_A0.UCA0CLK ⁽²⁾	X	1	0
		S30	X	X	1

(1) X = don't care

(2) The pin direction is controlled by the USCI module.

6.10.18 Port P7, P7.4 to P7.7, Input/Output With Schmitt Trigger

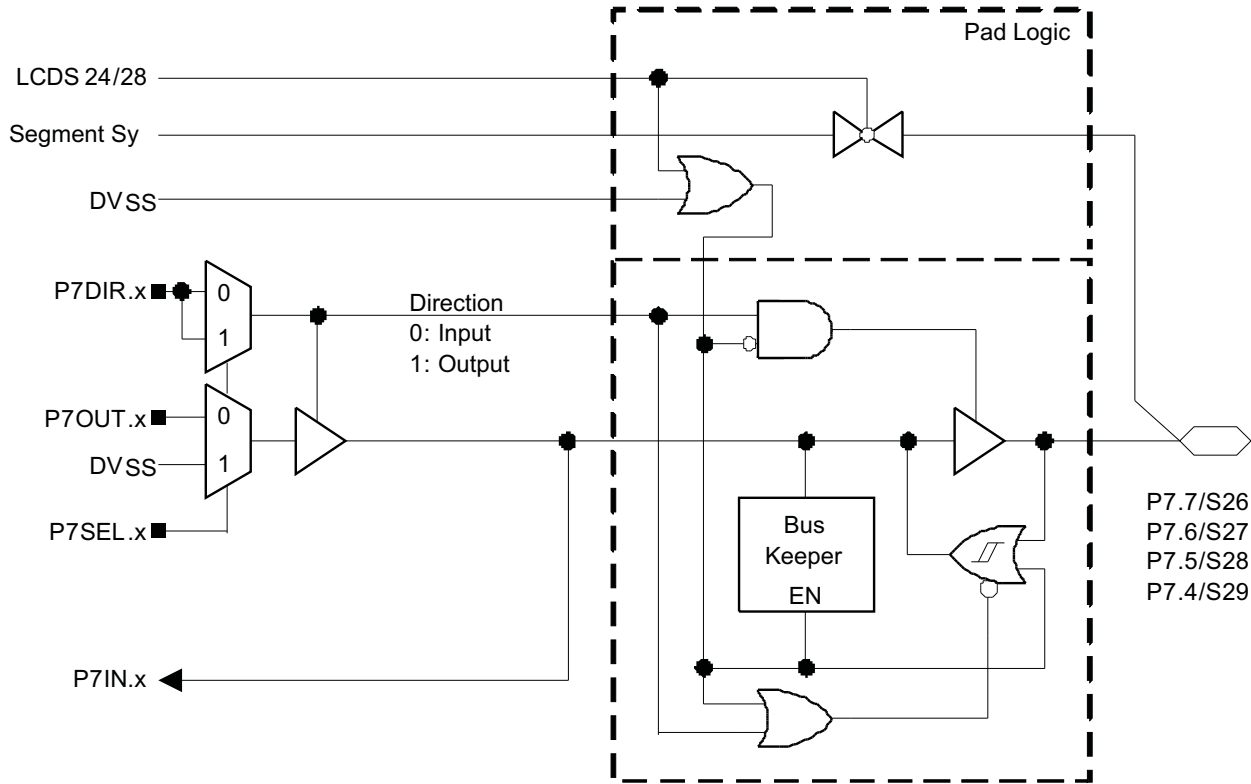

Note: x = 4, 5, 6, 7
y = 26, 27, 28, 29

Table 6-30. Port P7 (P7.4 and P7.5) Pin Functions

PIN NAME (P7.x)	x	FUNCTION	CONTROL BITS OR SIGNALS ⁽¹⁾		
			P7DIR.x	P7SEL.x	LCDS28
P7.4/S29	4	P7.4 (I/O)	I: 0; O: 1	0	0
		S29	X	X	1
P7.5/S28	5	P7.5 (I/O)	I: 0; O: 1	0	0
		S28	X	X	1

(1) X = don't care

Table 6-31. Port P7 (P7.6 and P7.7) Pin Functions

PIN NAME (P7.x)	x	FUNCTION	CONTROL BITS OR SIGNALS ⁽¹⁾		
			P7DIR.x	P7SEL.x	LCDS24
P7.6/S27	6	P7.6 (I/O)	I: 0; O: 1	0	0
		S27	X	X	1
P7.7/S26	7	P7.7 (I/O)	I: 0; O: 1	0	0
		S26	X	X	1

(1) X = don't care

6.10.19 Port P8, P8.0 to P8.7, Input/Output With Schmitt Trigger

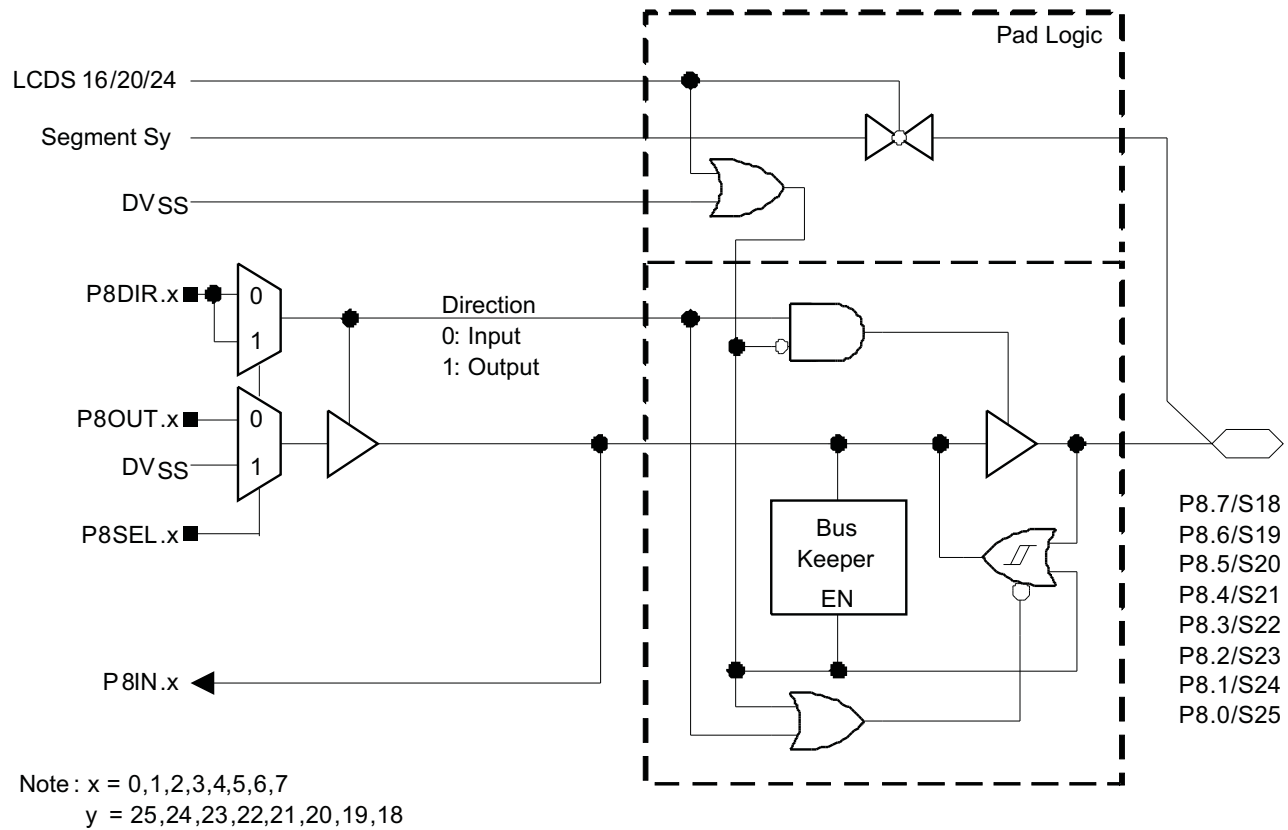

Table 6-32. Port P8 (P8.0 and P8.1) Pin Functions

PIN NAME (P8.x)	x	FUNCTION	CONTROL BITS OR SIGNALS ⁽¹⁾		
			P8DIR.x	P8SEL.x	LCDS16
P8.0/S18	0	P8.0 (I/O)	I: 0; O: 1	0	0
		S18	X	X	1
P8.1/S19	0	P8.0 (I/O)	I: 0; O: 1	0	0
		S19	X	X	1

(1) X = don't care

Table 6-33. Port P8 (P8.2 to P8.5) Pin Functions

PIN NAME (P8.x)	x	FUNCTION	CONTROL BITS OR SIGNALS ⁽¹⁾		
			P8DIR.x	P8SEL.x	LCDS20
P8.2/S20	2	P8.2 (I/O)	I: 0; O: 1	0	0
		S20	X	X	1
P8.3/S21	3	P8.3 (I/O)	I: 0; O: 1	0	0
		S21	X	X	1
P8.4/S22	4	P8.4 (I/O)	I: 0; O: 1	0	0
		S22	X	X	1
P8.5/S23	5	P8.5 (I/O)	I: 0; O: 1	0	0
		S23	X	X	1

(1) X = don't care

Table 6-34. Port P8 (P8.6 and P8.7) Pin Functions

PIN NAME (P8.x)	X	FUNCTION	CONTROL BITS OR SIGNALS ⁽¹⁾		
			P8DIR.x	P8SEL.x	LCDS24
P8.6/S24	6	P8.6 (I/O)	I: 0; O: 1	0	0
		S24	X	X	1
P8.7/S25	7	P8.7 (I/O)	I: 0; O: 1	0	0
		S25	X	X	1

(1) X = don't care

6.10.20 Port P9, P9.0 to P9.7, Input/Output With Schmitt Trigger

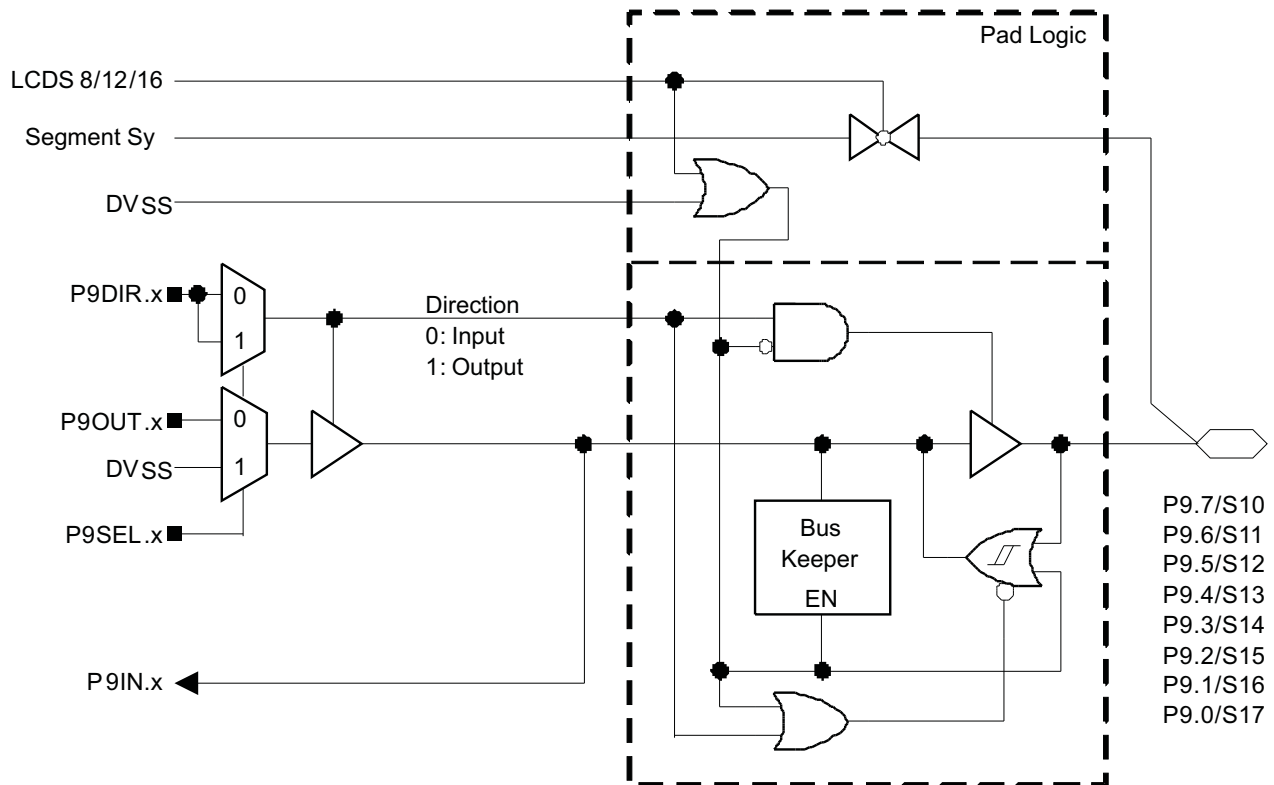

Note : x = 0,1,2,3,4,5,6,7
y = 17,16,15,14,13,12,11,10

Table 6-35. Port P9 (P9.0 and P9.1) Pin Functions

PIN NAME (P9.x)	x	FUNCTION	CONTROL BITS OR SIGNALS ⁽¹⁾		
			P9DIR.x	P9SEL.x	LCDS16
P9.0/S17	0	P9.0 (I/O)	I: 0; O: 1	0	0
		S17	X	X	1
P9.1/S16	1	P9.1 (I/O)	I: 0; O: 1	0	0
		S16	X	X	1

(1) X = don't care

Table 6-36. Port P9 (P9.2 to P9.5) Pin Functions

PIN NAME (P9.x)	x	FUNCTION	CONTROL BITS OR SIGNALS ⁽¹⁾		
			P9DIR.x	P9SEL.x	LCDS12
P9.2/S15	2	P9.2 (I/O)	I: 0; O: 1	0	0
		S15	X	X	1
P9.3/S14	3	P9.3 (I/O)	I: 0; O: 1	0	0
		S14	X	X	1
P9.4/S13	4	P9.4 (I/O)	I: 0; O: 1	0	0
		S13	X	X	1
P9.5/S12	5	P9.5 (I/O)	I: 0; O: 1	0	0
		S12	X	X	1

(1) X = don't care

Table 6-37. Port P9 (P9.6 and P9.7) Pin Functions

PIN NAME (P9.x)	x	FUNCTION	CONTROL BITS OR SIGNALS ⁽¹⁾		
			P9DIR.x	P9SEL.x	LCDS8
P9.6/S11	6	P9.6 (I/O)	I: 0; O: 1	0	0
		S11	X	X	1
P9.7/S10	7	P9.7 (I/O)	I: 0; O: 1	0	0
		S10	X	X	1

(1) X = don't care

6.10.21 Port P10, P10.0 to P10.5, Input/Output With Schmitt Trigger

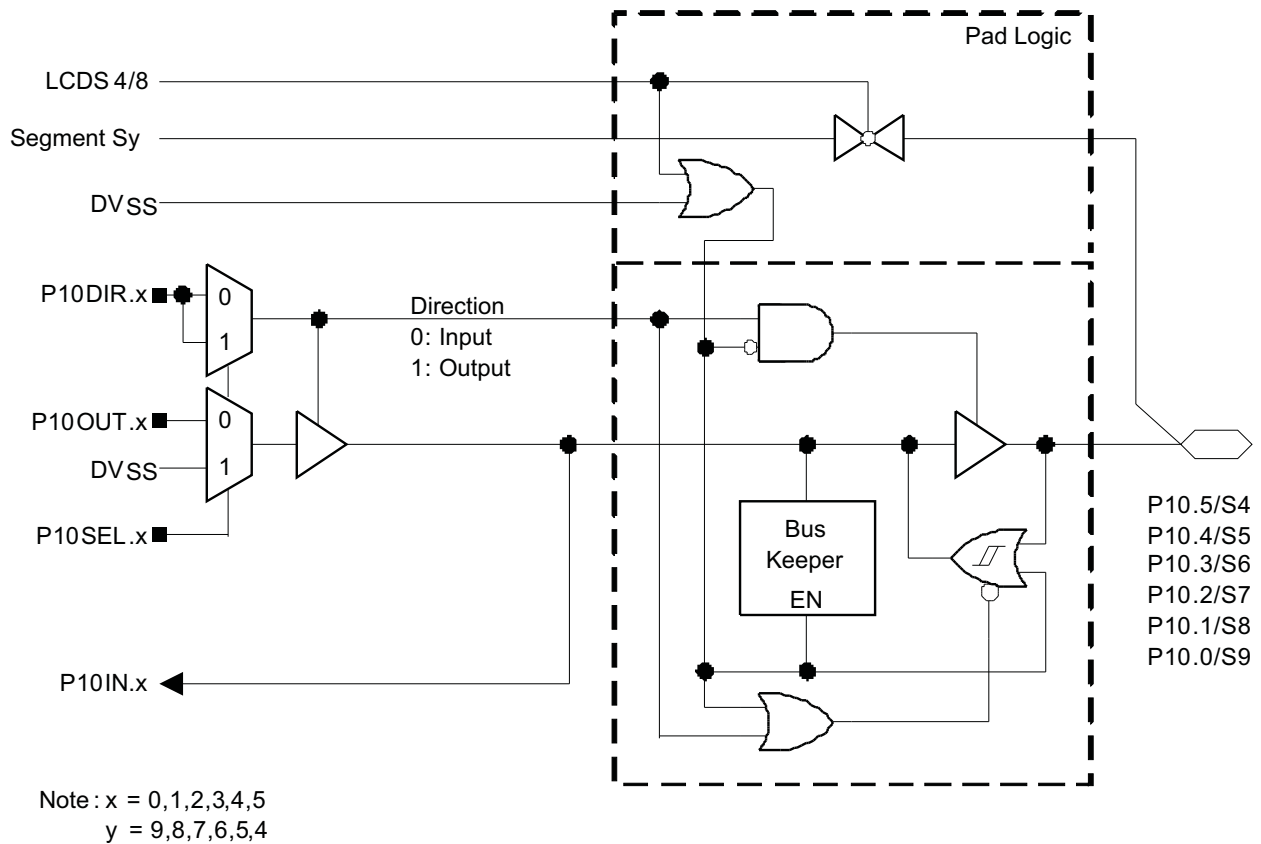

Table 6-38. Port P10 (P10.0 and P10.1) Pin Functions

PIN NAME (P10.x)	x	FUNCTION	CONTROL BITS OR SIGNALS ⁽¹⁾		
			P10DIR.x	P10SEL.x	LCDS8
P10.0/S9	0	P10.0 (I/O)	I: 0; O: 1	0	0
		S9	X	X	1
P10.1/S8	1	P10.1 (I/O)	I: 0; O: 1	0	0
		S8	X	X	1

(1) X = don't care

Table 6-39. Port P10 (P10.2 to P10.5) Pin Functions

PIN NAME (P10.x)	x	FUNCTION	CONTROL BITS OR SIGNALS ⁽¹⁾		
			P10DIR.x	P10SEL.x	LCDS4
P10.2/S7	2	P10.2 (I/O)	I: 0; O: 1	0	0
		S7	X	X	1
P10.3/S6	3	P10.3 (I/O)	I: 0; O: 1	0	0
		S6	X	X	1
P10.4/S5	4	P10.4 (I/O)	I: 0; O: 1	0	0
		S5	X	X	1
P10.5/S4	5	P10.5 (I/O)	I: 0; O: 1	0	0
		S4	X	X	1

(1) X = don't care

6.10.22 Port P10, P10.6, Input/Output With Schmitt Trigger

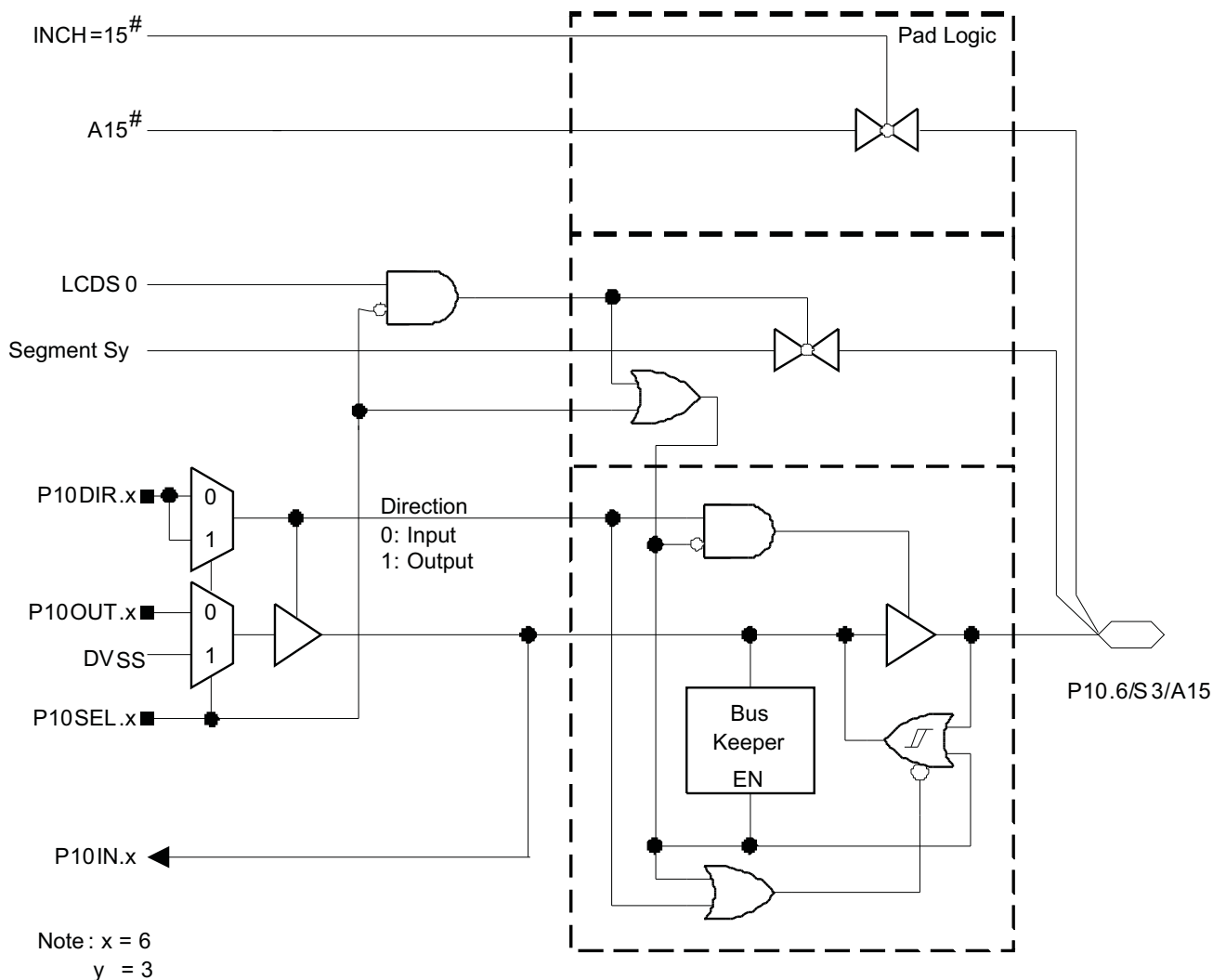

Table 6-40. Port P10 (P10.6) Pin Functions

PIN NAME (P10.x)	x	FUNCTION	CONTROL BITS OR SIGNALS ⁽¹⁾			
			P10DIR.x	P10SEL.x	INCHx	LCDS0
P10.6/S3/A15	6	P5.0 (I/O)	I: 0; O: 1	0	X	0
		A15 ⁽²⁾	X	1	15	0
		S3 enabled	X	0	X	1
		S3 disabled	X	1	X	1

(1) X = don't care

(2) Setting the P10SEL.x bit disables the output driver and the input Schmitt trigger to prevent parasitic cross currents when applying analog signals.

6.10.23 Port P10, P10.7, Input/Output With Schmitt Trigger

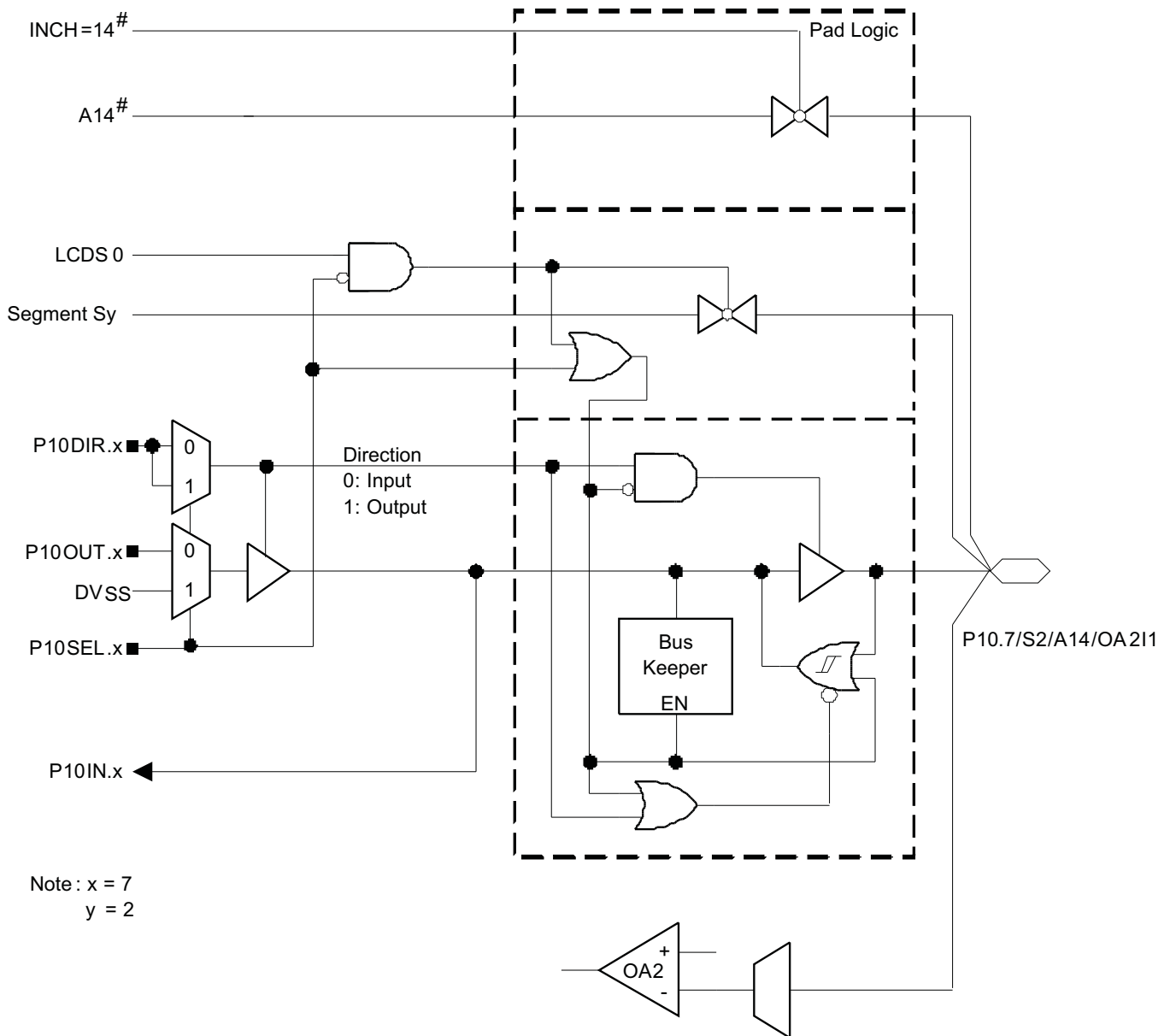

Table 6-41. Port P10 (P10.7) Pin Functions

PIN NAME (P10.x)	x	FUNCTION	CONTROL BITS OR SIGNALS ⁽¹⁾				
			P10DIR.x	P10SEL.x	INCHx	OAPx (OA1) OANx (OA1)	LCDS0
P10.7/S2/A14/OA211	7	P10.7(I/O)	I: 0; O: 1	0	X	X	0
		A14 ⁽²⁾	X	1	14	X	0
		OA211 ⁽²⁾	0	X	X	1	0
		S2 enabled	X	0	X	X	1
		S2 disabled	X	1	X	X	1

(1) X = don't care

(2) Setting the P10SEL.x bit disables the output driver and the input Schmitt trigger to prevent parasitic cross currents when applying analog signals.

6.10.24 $V_{e_{REF+}/DAC0}$

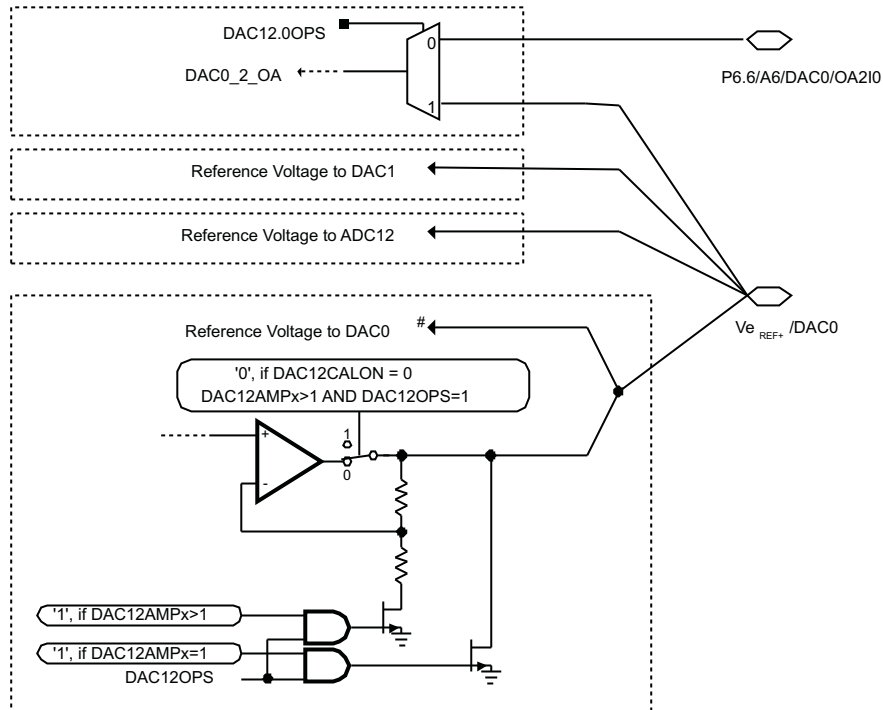

If the reference of DAC0 is taken from pin $V_{e_{REF+}/DAC0}$, unpredictable voltage levels will be on pin. In this situation, the DAC0 output is fed back to its own reference input.

6.10.25 JTAG Pins TMS, TCK, TDI/TCLK, TDO/TDI, Input/Output With Schmitt Trigger or Output

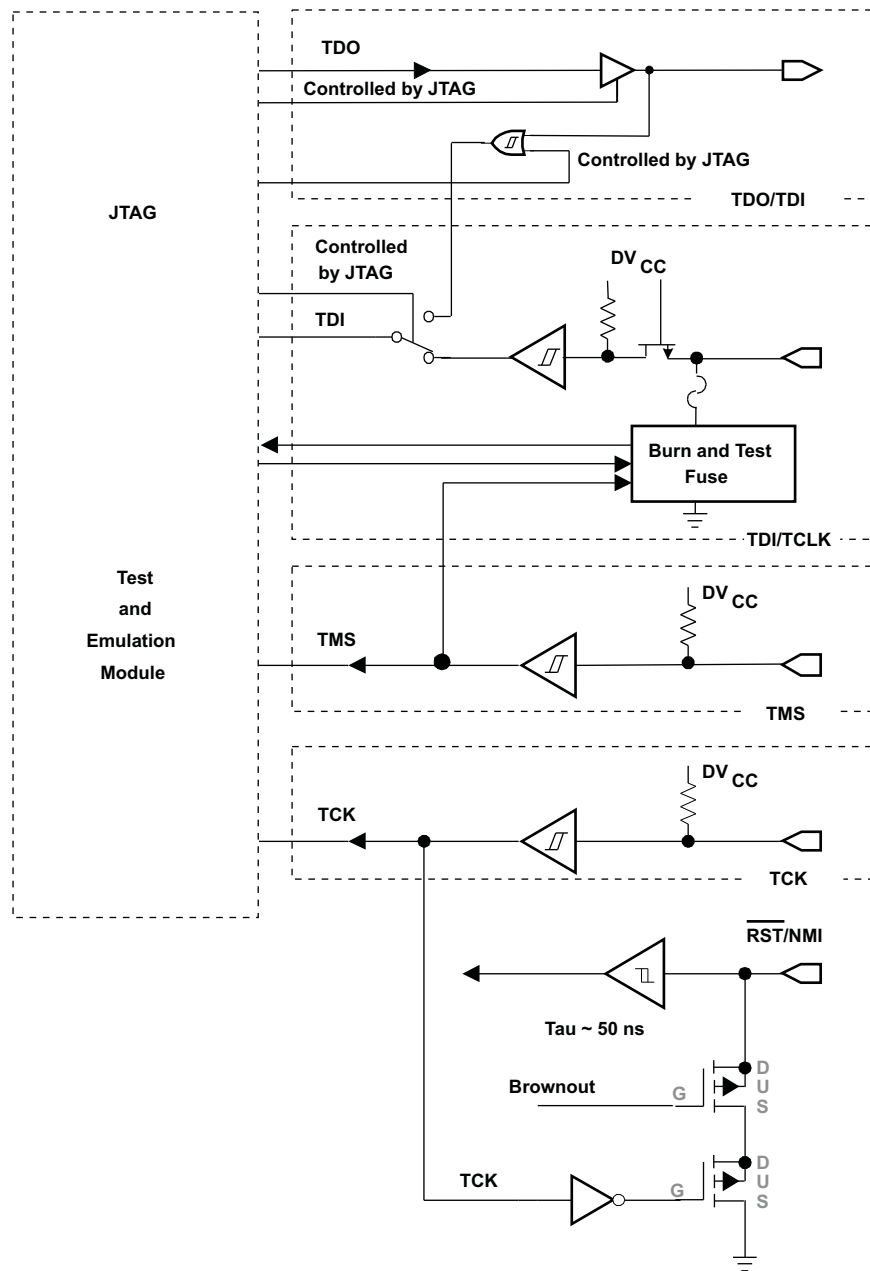

6.10.26 JTAG Fuse Check Mode

Devices that have the fuse on the TDI/TCLK terminal have a fuse check mode that tests the continuity of the fuse the first time the JTAG port is accessed after a power-on reset (POR). When activated, a fuse check current ($I_{(TF)}$) of 1 mA at 3 V can flow from the TDI/TCLK pin to ground if the fuse is not burned. Care must be taken to avoid accidentally activating the fuse check mode and increasing overall system power consumption.

Activation of the fuse check mode occurs with the first negative edge on the TMS pin after power up or if the TMS is being held low during power up. The second positive edge on the TMS pin deactivates the fuse check mode. After deactivation, the fuse check mode remains inactive until another POR occurs. After each POR the fuse check mode has the potential to be activated.

The fuse check current only flows when the fuse check mode is active and the TMS pin is in a low state (see Figure 6-1). Therefore, the additional current flow can be prevented by holding the TMS pin high (default condition). The JTAG pins are terminated internally and therefore do not require external termination.

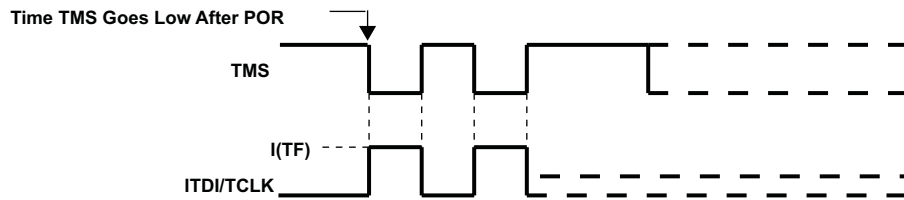

Figure 6-1. Fuse Check Mode Current

7 Device and Documentation Support

7.1 Device Support

7.1.1 Getting Started and Next Steps

For more information on the MSP430F4x family of devices and the tools and libraries that are available to help with your development, visit the [Getting Started](#) page.

7.1.2 Development Tools Support

All MSP430™ microcontrollers are supported by a wide variety of software and hardware development tools. Tools are available from TI and various third parties. See them all at www.ti.com/msp430tools.

7.1.2.1 Hardware Features

See the *Composer Studio for MSP430 User's Guide* ([SLAU157](#)) for details on the available features.

MSP430 Architecture	4-Wire JTAG	2-Wire JTAG	Break-points (N)	Range Break-points	Clock Control	State Sequencer	Trace Buffer	LPMx.5 Debugging Support
MSP430	Yes	No	2	No	Yes	No	No	No

7.1.2.2 Recommended Hardware Options

7.1.2.2.1 Target Socket Boards

The target socket boards allow easy programming and debugging of the device using JTAG. They also feature header pin outs for prototyping. Target socket boards are orderable individually or as a kit with the JTAG programmer and debugger included. The following table shows the compatible target boards and the supported packages.

Package	Target Board and Programmer Bundle	Target Board Only
100-pin LQFP (PZ)	MSP-FET430U100	MSP-TS430PZ100

7.1.2.2.2 Experimenter Boards

Experimenter Boards and Evaluation kits are available for some MSP430 devices. These kits feature additional hardware components and connectivity for full system evaluation and prototyping. See www.ti.com/msp430tools for details.

7.1.2.2.3 Debugging and Programming Tools

Hardware programming and debugging tools are available from TI and from its third party suppliers. See the full list of available tools at www.ti.com/msp430tools.

7.1.2.2.4 Production Programmers

The production programmers expedite loading firmware to devices by programming several devices simultaneously.

Part Number	PC Port	Features	Provider
MSP-GANG	Serial and USB	Program up to eight devices at a time. Works with PC or standalone.	Texas Instruments

7.1.2.3 Recommended Software Options

7.1.2.3.1 Integrated Development Environments

Software development tools are available from TI or from third parties. Open source solutions are also available.

This device is supported by Code Composer Studio™ IDE (CCS).

7.1.2.3.2 *MSP430Ware*

[MSP430Ware](#) is a collection of code examples, data sheets, and other design resources for all MSP430 devices delivered in a convenient package. In addition to providing a complete collection of existing MSP430 design resources, MSP430Ware also includes a high-level API called MSP430 Driver Library. This library makes it easy to program MSP430 hardware. MSP430Ware is available as a component of CCS or as a standalone package.

7.1.2.3.3 *Command-Line Programmer*

[MSP430 Flasher](#) is an open-source shell-based interface for programming MSP430 microcontrollers through a FET programmer or eZ430 using JTAG or Spy-Bi-Wire (SBW) communication. MSP430 Flasher can be used to download binary files (.txt or .hex) files directly to the MSP430 microcontroller without the need for an IDE.

7.1.3 *Device and Development Tool Nomenclature*

To designate the stages in the product development cycle, TI assigns prefixes to the part numbers of all MSP430 MCU devices and support tools. Each MSP430 MCU commercial family member has one of three prefixes: MSP, PMS, or XMS (for example, MSP430F5438A). TI recommends two of three possible prefix designators for its support tools: MSP and MSPX. These prefixes represent evolutionary stages of product development from engineering prototypes (with XMS for devices and MSPX for tools) through fully qualified production devices and tools (with MSP for devices and MSP for tools).

Device development evolutionary flow:

XMS – Experimental device that is not necessarily representative of the electrical specifications for the final device

PMS – Final silicon die that conforms to the electrical specifications for the device but has not completed quality and reliability verification

MSP – Fully qualified production device

Support tool development evolutionary flow:

MSPX – Development-support product that has not yet completed TI's internal qualification testing.

MSP – Fully-qualified development-support product

XMS and PMS devices and MSPX development-support tools are shipped against the following disclaimer:

"Developmental product is intended for internal evaluation purposes."

MSP devices and MSP development-support tools have been characterized fully, and the quality and reliability of the device have been demonstrated fully. TI's standard warranty applies.

Predictions show that prototype devices (XMS and PMS) have a greater failure rate than the standard production devices. TI recommends that these devices not be used in any production system because their expected end-use failure rate still is undefined. Only qualified production devices are to be used.

TI device nomenclature also includes a suffix with the device family name. This suffix indicates the package type (for example, PZP) and temperature range (for example, T). [Figure 7-1](#) provides a legend for reading the complete device name for any family member.

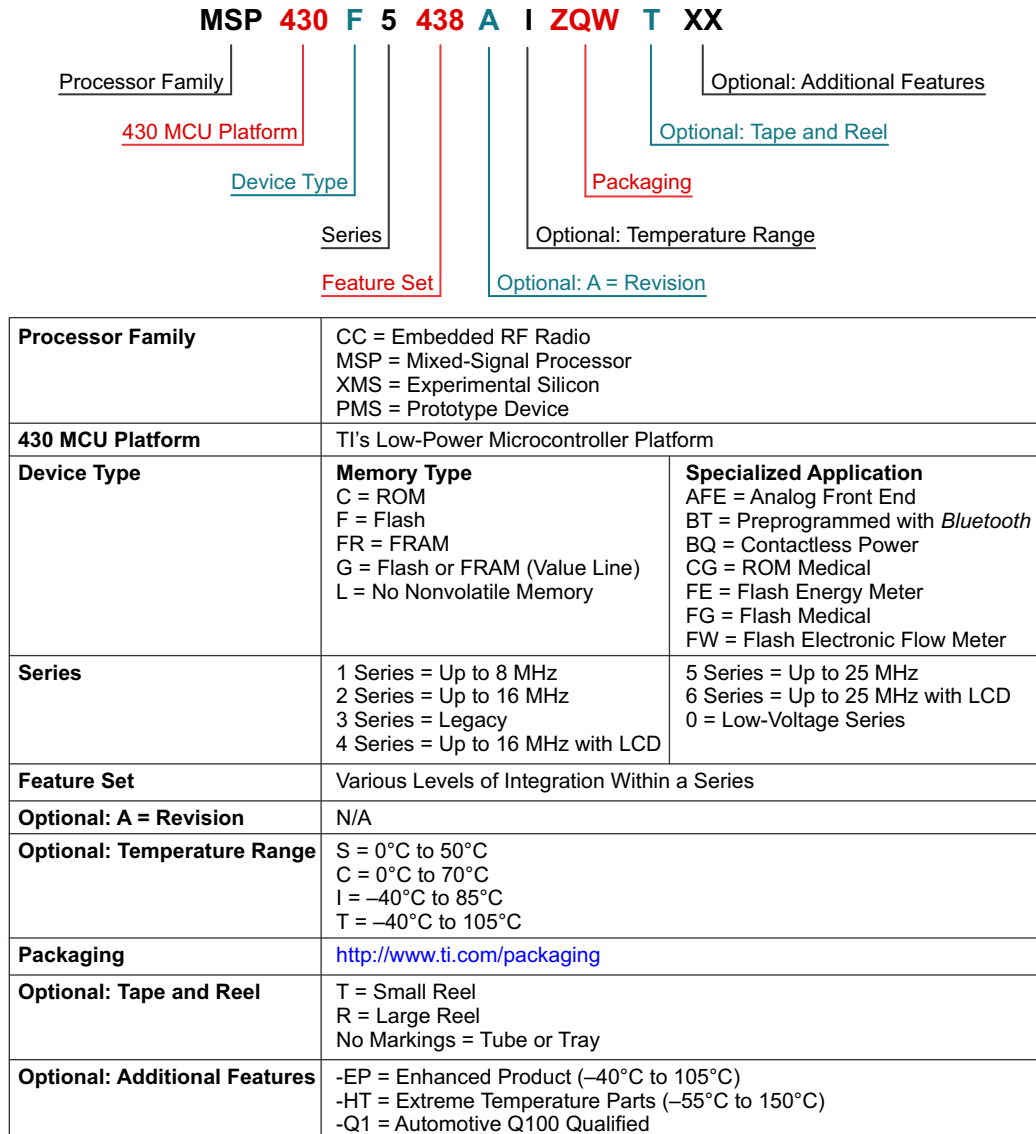

Figure 7-1. Device Nomenclature

7.2 Documentation Support

The following documents describe the MSP430FG461x and MSP430CG461x devices. Copies of these documents are available on the Internet at www.ti.com.

- [SLAU056](#) **MSP430F4xx Family User's Guide.** Detailed information on the modules and peripherals available in this device family.
- [SLAZ369](#) **MSP430FG4619 Device Erratasheet.** Describes the known exceptions to the functional specifications for all silicon revisions of the device.
- [SLAZ368](#) **MSP430FG4618 Device Erratasheet.** Describes the known exceptions to the functional specifications for all silicon revisions of the device.
- [SLAZ367](#) **MSP430FG4617 Device Erratasheet.** Describes the known exceptions to the functional specifications for all silicon revisions of the device.
- [SLAZ366](#) **MSP430FG4616 Device Erratasheet.** Describes the known exceptions to the functional specifications for all silicon revisions of the device.
- [SLAZ123](#) **MSP430CG4619 Device Erratasheet.** Describes the known exceptions to the functional specifications for all silicon revisions of the device.
- [SLAZ122](#) **MSP430CG4618 Device Erratasheet.** Describes the known exceptions to the functional specifications for all silicon revisions of the device.
- [SLAZ121](#) **MSP430CG4617 Device Erratasheet.** Describes the known exceptions to the functional specifications for all silicon revisions of the device.
- [SLAZ120](#) **MSP430CG4616 Device Erratasheet.** Describes the known exceptions to the functional specifications for all silicon revisions of the device.

7.3 Related Links

[Table 7-1](#) lists quick access links. Categories include technical documents, support and community resources, tools and software, and quick access to sample or buy.

Table 7-1. Related Links

PARTS	PRODUCT FOLDER	SAMPLE & BUY	TECHNICAL DOCUMENTS	TOOLS & SOFTWARE	SUPPORT & COMMUNITY
MSP430FG4619	Click here	Click here	Click here	Click here	Click here
MSP430FG4618	Click here	Click here	Click here	Click here	Click here
MSP430FG4617	Click here	Click here	Click here	Click here	Click here
MSP430FG4616	Click here	Click here	Click here	Click here	Click here
MSP430CG4619	Click here	Click here	Click here	Click here	Click here
MSP430CG4618	Click here	Click here	Click here	Click here	Click here
MSP430CG4617	Click here	Click here	Click here	Click here	Click here
MSP430CG4616	Click here	Click here	Click here	Click here	Click here

7.4 Community Resources

The following links connect to TI community resources. Linked contents are provided "AS IS" by the respective contributors. They do not constitute TI specifications and do not necessarily reflect TI's views; see TI's [Terms of Use](#).

[TI E2E™ Community](#)

TI's Engineer-to-Engineer (E2E) Community. Created to foster collaboration among engineers. At e2e.ti.com, you can ask questions, share knowledge, explore ideas, and help solve problems with fellow engineers.

[TI Embedded Processors Wiki](#)

Texas Instruments Embedded Processors Wiki. Established to help developers get started with embedded processors from Texas Instruments and to foster innovation and growth of general knowledge about the hardware and software surrounding these devices.

7.5 Trademarks

MSP430, MicroStar Junior, Code Composer Studio, E2E are trademarks of Texas Instruments.

7.6 Electrostatic Discharge Caution



This integrated circuit can be damaged by ESD. Texas Instruments recommends that all integrated circuits be handled with appropriate precautions. Failure to observe proper handling and installation procedures can cause damage.

ESD damage can range from subtle performance degradation to complete device failure. Precision integrated circuits may be more susceptible to damage because very small parametric changes could cause the device not to meet its published specifications.

7.7 Export Control Notice

Recipient agrees to not knowingly export or re-export, directly or indirectly, any product or technical data (as defined by the U.S., EU, and other Export Administration Regulations) including software, or any controlled product restricted by other applicable national regulations, received from disclosing party under nondisclosure obligations (if any), or any direct product of such technology, to any destination to which such export or re-export is restricted or prohibited by U.S. or other applicable laws, without obtaining prior authorization from U.S. Department of Commerce and other competent Government authorities to the extent required by those laws.

7.8 Glossary

[SLYZ022](#) — *TI Glossary*.

This glossary lists and explains terms, acronyms, and definitions.

8 Mechanical, Packaging, and Orderable Information

The following pages include mechanical, packaging, and orderable information. This information is the most current data available for the designated devices. This data is subject to change without notice and revision of this document. For browser-based versions of this data sheet, refer to the left-hand navigation.

PACKAGING INFORMATION

Orderable Device	Status (1)	Package Type	Package Drawing	Pins	Package Qty	Eco Plan (2)	Lead/Ball Finish (6)	MSL Peak Temp (3)	Op Temp (°C)	Device Marking (4/5)	Samples
MSP430FG4616IPZ	ACTIVE	LQFP	PZ	100	90	Green (RoHS & no Sb/Br)	CU NIPDAU	Level-3-260C-168 HR	-40 to 85	M430FG4616	Samples
MSP430FG4616IPZR	ACTIVE	LQFP	PZ	100	1000	Green (RoHS & no Sb/Br)	CU NIPDAU	Level-3-260C-168 HR	-40 to 85	M430FG4616	Samples
MSP430FG4616IZQW	LIFEBUY	BGA MICROSTAR JUNIOR	ZQW	113	260	Green (RoHS & no Sb/Br)	SNAGCU	Level-3-260C-168 HR	-40 to 85	M430FG4616	
MSP430FG4616IZQWR	LIFEBUY	BGA MICROSTAR JUNIOR	ZQW	113	2500	Green (RoHS & no Sb/Br)	SNAGCU	Level-3-260C-168 HR	-40 to 85	M430FG4616	
MSP430FG4617IPZ	ACTIVE	LQFP	PZ	100	90	Green (RoHS & no Sb/Br)	CU NIPDAU	Level-3-260C-168 HR	-40 to 85	M430FG4617	Samples
MSP430FG4617IZQWR	ACTIVE	BGA MICROSTAR JUNIOR	ZQW	113	2500	Green (RoHS & no Sb/Br)	SNAGCU	Level-3-260C-168 HR	-40 to 85	M430FG4617	Samples
MSP430FG4618IPZ	ACTIVE	LQFP	PZ	100	90	Green (RoHS & no Sb/Br)	CU NIPDAU	Level-3-260C-168 HR	-40 to 85	M430FG4618	Samples
MSP430FG4618IPZR	ACTIVE	LQFP	PZ	100	1000	Green (RoHS & no Sb/Br)	CU NIPDAU	Level-3-260C-168 HR	-40 to 85	M430FG4618	Samples
MSP430FG4618IZQW	LIFEBUY	BGA MICROSTAR JUNIOR	ZQW	113	260	Green (RoHS & no Sb/Br)	SNAGCU	Level-3-260C-168 HR	-40 to 85	M430FG4618	
MSP430FG4618IZQWR	LIFEBUY	BGA MICROSTAR JUNIOR	ZQW	113	2500	Green (RoHS & no Sb/Br)	SNAGCU	Level-3-260C-168 HR	-40 to 85	M430FG4618	
MSP430FG4618IZQWT	LIFEBUY	BGA MICROSTAR JUNIOR	ZQW	113	250	Green (RoHS & no Sb/Br)	SNAGCU	Level-3-260C-168 HR		M430FG4618	
MSP430FG4619IPZ	ACTIVE	LQFP	PZ	100	90	Green (RoHS & no Sb/Br)	CU NIPDAU	Level-3-260C-168 HR	-40 to 85	M430FG4619 REV #	Samples
MSP430FG4619IPZR	ACTIVE	LQFP	PZ	100	1000	Green (RoHS & no Sb/Br)	CU NIPDAU	Level-3-260C-168 HR	-40 to 85	M430FG4619	Samples
MSP430FG4619IZQWR	LIFEBUY	BGA MICROSTAR JUNIOR	ZQW	113	2500	Green (RoHS & no Sb/Br)	SNAGCU	Level-3-260C-168 HR	-40 to 85	M430FG4619	

(1) The marketing status values are defined as follows:

ACTIVE: Product device recommended for new designs.

LIFEBUY: TI has announced that the device will be discontinued, and a lifetime-buy period is in effect.

NRND: Not recommended for new designs. Device is in production to support existing customers, but TI does not recommend using this part in a new design.

PREVIEW: Device has been announced but is not in production. Samples may or may not be available.

OBSOLETE: TI has discontinued the production of the device.

(2) **RoHS:** TI defines "RoHS" to mean semiconductor products that are compliant with the current EU RoHS requirements for all 10 RoHS substances, including the requirement that RoHS substance do not exceed 0.1% by weight in homogeneous materials. Where designed to be soldered at high temperatures, "RoHS" products are suitable for use in specified lead-free processes. TI may reference these types of products as "Pb-Free".

RoHS Exempt: TI defines "RoHS Exempt" to mean products that contain lead but are compliant with EU RoHS pursuant to a specific EU RoHS exemption.

Green: TI defines "Green" to mean the content of Chlorine (Cl) and Bromine (Br) based flame retardants meet JS709B low halogen requirements of ≤ 1000 ppm threshold. Antimony trioxide based flame retardants must also meet the ≤ 1000 ppm threshold requirement.

(3) MSL, Peak Temp. - The Moisture Sensitivity Level rating according to the JEDEC industry standard classifications, and peak solder temperature.

(4) There may be additional marking, which relates to the logo, the lot trace code information, or the environmental category on the device.

(5) Multiple Device Markings will be inside parentheses. Only one Device Marking contained in parentheses and separated by a "~" will appear on a device. If a line is indented then it is a continuation of the previous line and the two combined represent the entire Device Marking for that device.

(6) Lead/Ball Finish - Orderable Devices may have multiple material finish options. Finish options are separated by a vertical ruled line. Lead/Ball Finish values may wrap to two lines if the finish value exceeds the maximum column width.

Important Information and Disclaimer: The information provided on this page represents TI's knowledge and belief as of the date that it is provided. TI bases its knowledge and belief on information provided by third parties, and makes no representation or warranty as to the accuracy of such information. Efforts are underway to better integrate information from third parties. TI has taken and continues to take reasonable steps to provide representative and accurate information but may not have conducted destructive testing or chemical analysis on incoming materials and chemicals. TI and TI suppliers consider certain information to be proprietary, and thus CAS numbers and other limited information may not be available for release.

In no event shall TI's liability arising out of such information exceed the total purchase price of the TI part(s) at issue in this document sold by TI to Customer on an annual basis.

TAPE AND REEL INFORMATION

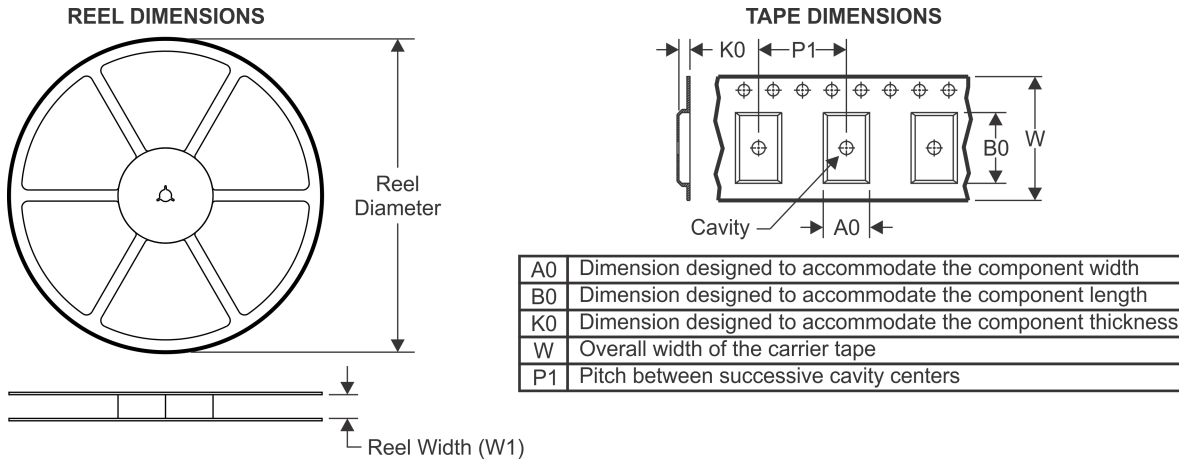

QUADRANT ASSIGNMENTS FOR PIN 1 ORIENTATION IN TAPE

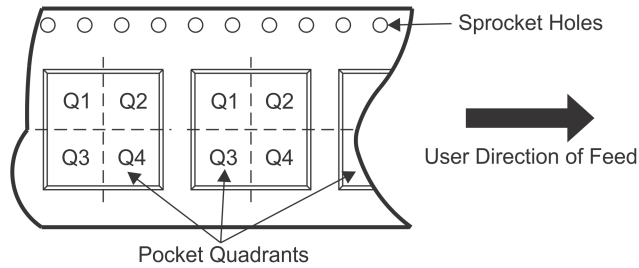

*All dimensions are nominal

Device	Package Type	Package Drawing	Pins	SPQ	Reel Diameter (mm)	Reel Width W1 (mm)	A0 (mm)	B0 (mm)	K0 (mm)	P1 (mm)	W (mm)	Pin1 Quadrant
MSP430FG4616IPZR	LQFP	PZ	100	1000	330.0	24.4	17.0	17.0	2.1	20.0	24.0	Q2
MSP430FG4616IZQWR	BGA MICROSTAR JUNIOR	ZQW	113	2500	330.0	16.4	7.3	7.3	1.5	12.0	16.0	Q1
MSP430FG4617IZQWR	BGA MICROSTAR JUNIOR	ZQW	113	2500	330.0	16.4	7.3	7.3	1.5	12.0	16.0	Q1
MSP430FG4618IPZR	LQFP	PZ	100	1000	330.0	24.4	17.0	17.0	2.1	20.0	24.0	Q2
MSP430FG4618IZQWR	BGA MICROSTAR JUNIOR	ZQW	113	2500	330.0	16.4	7.3	7.3	1.5	12.0	16.0	Q1
MSP430FG4618IZQWT	BGA MICROSTAR JUNIOR	ZQW	113	250	180.0	16.4	7.3	7.3	1.5	12.0	16.0	Q1
MSP430FG4619IPZR	LQFP	PZ	100	1000	330.0	24.4	17.0	17.0	2.1	20.0	24.0	Q2
MSP430FG4619IZQWR	BGA MICROSTAR JUNIOR	ZQW	113	2500	330.0	16.4	7.3	7.3	1.5	12.0	16.0	Q1

Device	Package Type	Package Drawing	Pins	SPQ	Reel Diameter (mm)	Reel Width W1 (mm)	A0 (mm)	B0 (mm)	K0 (mm)	P1 (mm)	W (mm)	Pin1 Quadrant
	OR											

TAPE AND REEL BOX DIMENSIONS

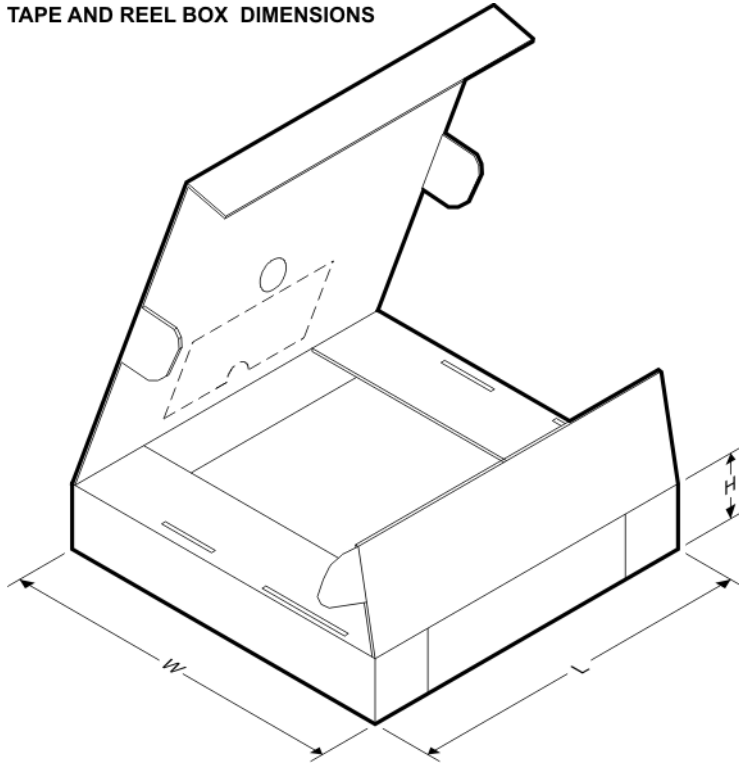

*All dimensions are nominal

Device	Package Type	Package Drawing	Pins	SPQ	Length (mm)	Width (mm)	Height (mm)
MSP430FG4616IPZR	LQFP	PZ	100	1000	367.0	367.0	45.0
MSP430FG4616IZQWR	BGA MICROSTAR JUNIOR	ZQW	113	2500	350.0	350.0	43.0
MSP430FG4617IZQWR	BGA MICROSTAR JUNIOR	ZQW	113	2500	350.0	350.0	43.0
MSP430FG4618IPZR	LQFP	PZ	100	1000	367.0	367.0	45.0
MSP430FG4618IZQWR	BGA MICROSTAR JUNIOR	ZQW	113	2500	350.0	350.0	43.0
MSP430FG4618IZQWT	BGA MICROSTAR JUNIOR	ZQW	113	250	213.0	191.0	55.0
MSP430FG4619IPZR	LQFP	PZ	100	1000	367.0	367.0	45.0
MSP430FG4619IZQWR	BGA MICROSTAR JUNIOR	ZQW	113	2500	350.0	350.0	43.0

PZ (S-PQFP-G100)

PLASTIC QUAD FLATPACK

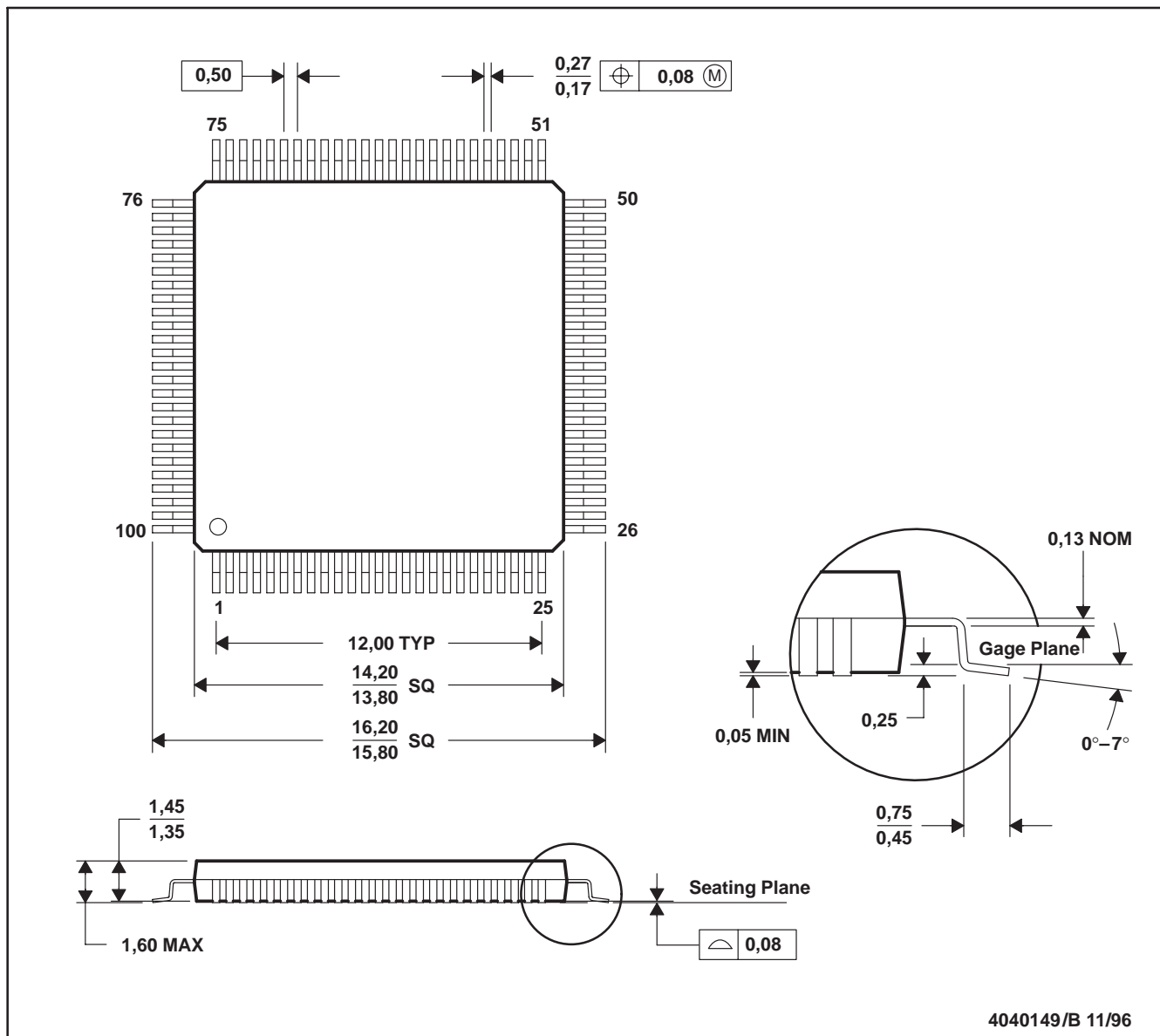

4040149/B 11/96

- NOTES: A. All linear dimensions are in millimeters.
 B. This drawing is subject to change without notice.
 C. Falls within JEDEC MS-026

PZ (S-PQFP-G100)

PLASTIC QUAD FLAT PACK

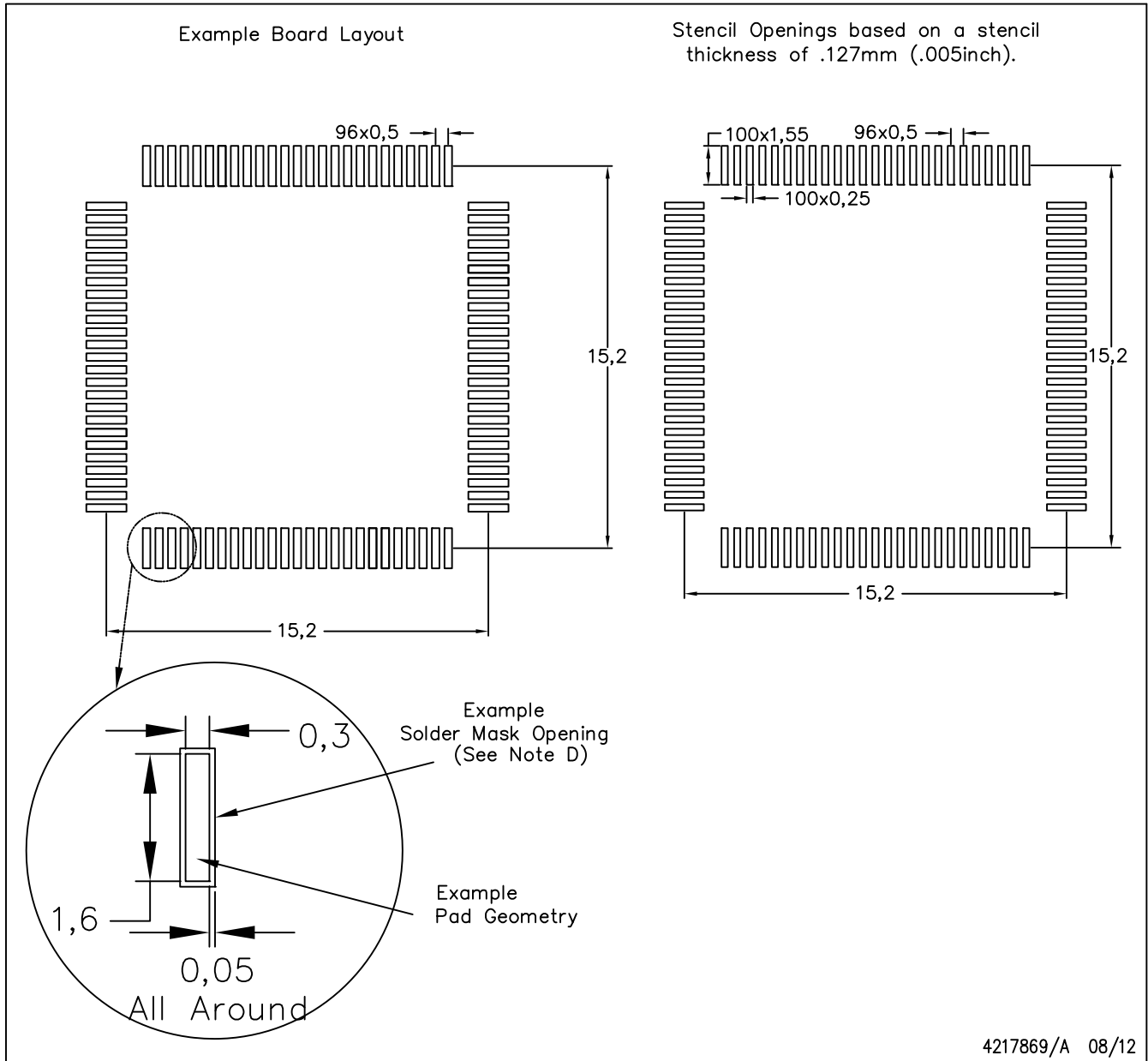

NOTES:

- All linear dimensions are in millimeters.
- This drawing is subject to change without notice.
- Laser cutting apertures with trapezoidal walls and also rounding corners will offer better paste release. Customers should contact their board assembly site for stencil design recommendations. Example stencil design based on a 50% volumetric metal load solder paste. Refer to IPC-7525 for other stencil recommendations.
- Customers should contact their board fabrication site for solder mask tolerances between and around signal pads.

ZQW (S-PBGA-N113)

PLASTIC BALL GRID ARRAY

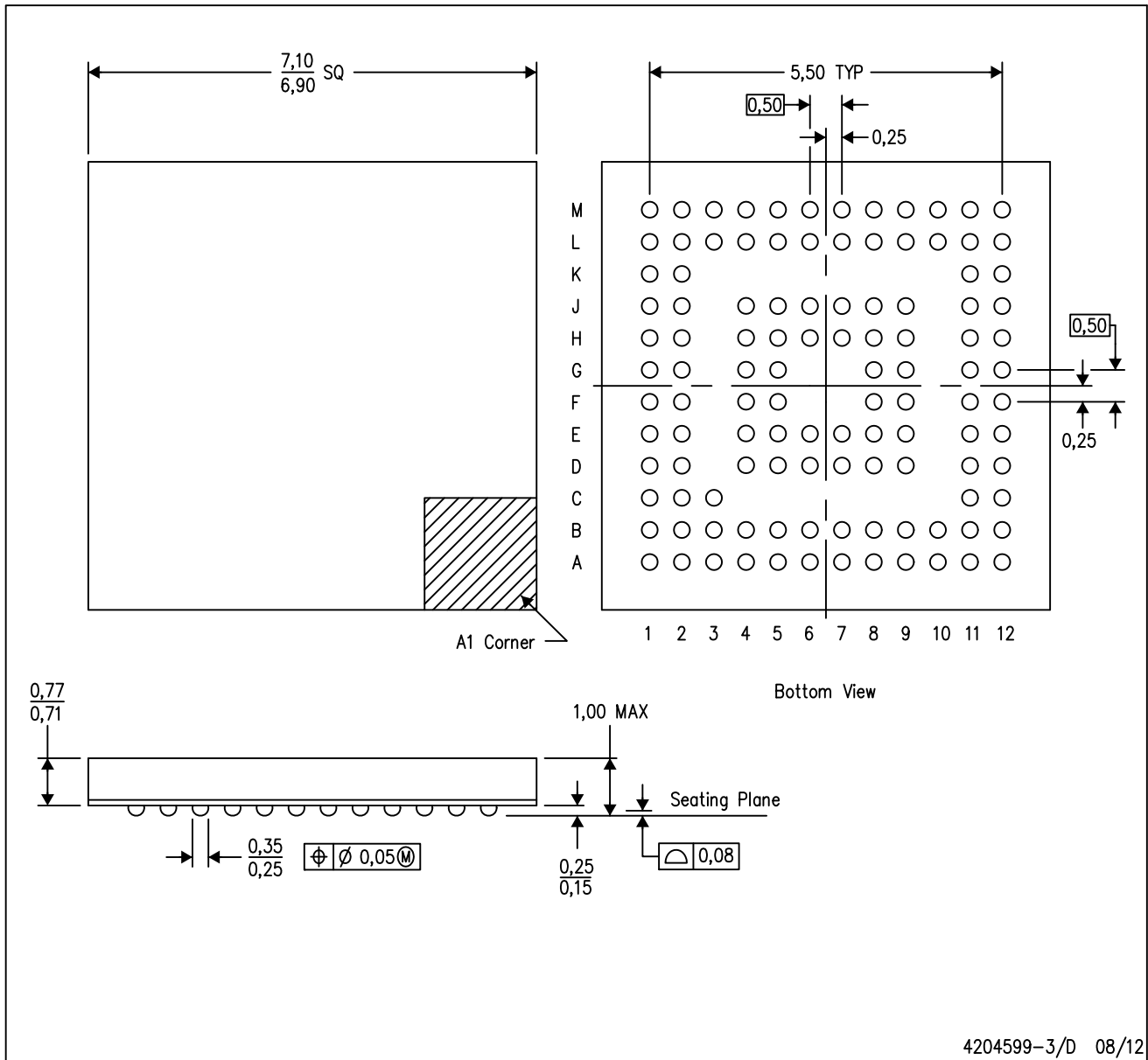

- NOTES:
- A. All linear dimensions are in millimeters.
 - B. This drawing is subject to change without notice.
 - C. Falls within JEDEC MO-225
 - D. This is a Pb-free solder ball design.

MicroStar Junior is a trademark of Texas Instruments.

IMPORTANT NOTICE AND DISCLAIMER

TI PROVIDES TECHNICAL AND RELIABILITY DATA (INCLUDING DATASHEETS), DESIGN RESOURCES (INCLUDING REFERENCE DESIGNS), APPLICATION OR OTHER DESIGN ADVICE, WEB TOOLS, SAFETY INFORMATION, AND OTHER RESOURCES "AS IS" AND WITH ALL FAULTS, AND DISCLAIMS ALL WARRANTIES, EXPRESS AND IMPLIED, INCLUDING WITHOUT LIMITATION ANY IMPLIED WARRANTIES OF MERCHANTABILITY, FITNESS FOR A PARTICULAR PURPOSE OR NON-INFRINGEMENT OF THIRD PARTY INTELLECTUAL PROPERTY RIGHTS.

These resources are intended for skilled developers designing with TI products. You are solely responsible for (1) selecting the appropriate TI products for your application, (2) designing, validating and testing your application, and (3) ensuring your application meets applicable standards, and any other safety, security, or other requirements. These resources are subject to change without notice. TI grants you permission to use these resources only for development of an application that uses the TI products described in the resource. Other reproduction and display of these resources is prohibited. No license is granted to any other TI intellectual property right or to any third party intellectual property right. TI disclaims responsibility for, and you will fully indemnify TI and its representatives against, any claims, damages, costs, losses, and liabilities arising out of your use of these resources.

TI's products are provided subject to TI's Terms of Sale (www.ti.com/legal/termsofsale.html) or other applicable terms available either on ti.com or provided in conjunction with such TI products. TI's provision of these resources does not expand or otherwise alter TI's applicable warranties or warranty disclaimers for TI products.

Mailing Address: Texas Instruments, Post Office Box 655303, Dallas, Texas 75265
Copyright © 2019, Texas Instruments Incorporated

Looking for pricing, stock, or lifecycle information?

Click below to explore more details on WIN SOURCE:

 [View MSP430FG4619IPZR on WIN SOURCE](#)

 [Texas Instruments](#) Information

Optimize Your Supply Chain with WIN SOURCE Solutions

-  Global Sourcing Solution
-  Obsolete Management
-  Cost Control Management
-  Shortage Management
-  Alternative Solution
-  Excess Inventory Management