



**THE DATASHEET OF  
SNJ54LS193J**



# SN54192, SN54193, SN54LS192, SN54LS193, SN74192, SN74193, SN74LS192, SN74LS193 SYNCHRONOUS 4-BIT UP/DOWN COUNTERS (DUAL CLOCK WITH CLEAR)

SDLS074 - DECEMBER 1972 - REVISED MARCH 1988

- Cascading Circuitry Provided Internally
- Synchronous Operation
- Individual Preset to Each Flip-Flop
- Fully Independent Clear Input

SN54192, SN54193, SN54LS192,  
SN54LS193 . . . J OR W PACKAGE  
SN74192, SN74193 . . . N PACKAGE  
SN74LS192, SN74LS193 . . . D OR N PACKAGE

TYPES	TYPICAL MAXIMUM COUNT FREQUENCY	TYPICAL POWER DISSIPATION
'192, '193	32 MHz	325 mW
'LS192, 'LS193	32 MHz	95 mW

(TOP VIEW)

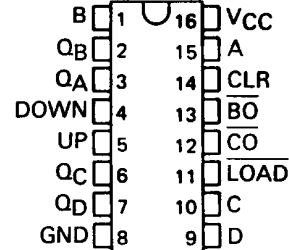

## description

These monolithic circuits are synchronous reversible (up/down) counters having a complexity of 55 equivalent gates. The '192 and 'LS192 circuits are BCD counters and the '193 and 'LS193 are 4-bit binary counters. Synchronous operation is provided by having all flip-flops clocked simultaneously so that the outputs change coincidentally with each other when so instructed by the steering logic. This mode of operation eliminates the output counting spikes which are normally associated with asynchronous (ripple-clock) counters.

The outputs of the four master-slave flip-flops are triggered by a low-to-high-level transition of either count (clock) input. The direction of counting is determined by which count input is pulsed while the other count input is high.

All four counters are fully programmable; that is, each output may be preset to either level by entering the desired data at the data inputs while the load input is low. The output will change to agree with the data inputs independently of the count pulses. This feature allows the counters to be used as modulo-N dividers by simply modifying the count length with the preset inputs.

A clear input has been provided which forces all outputs to the low level when a high level is applied. The clear function is independent of the count and load inputs. The clear, count, and load inputs are buffered to lower the drive requirements. This reduces the number of clock drivers, etc., required for long words.

These counters were designed to be cascaded without the need for external circuitry. Both borrow and carry outputs are available to cascade both the up- and down-counting functions. The borrow output produces a pulse equal in width to the count-down input when the counter underflows. Similarly, the carry output produces a pulse equal in width to the count-up input when an overflow condition exists. The counters can then be easily cascaded by feeding the borrow and carry outputs to the count-down and count-up inputs respectively of the succeeding counter.

SN54LS192, SN54LS193 . . . FK PACKAGE  
(TOP VIEW)

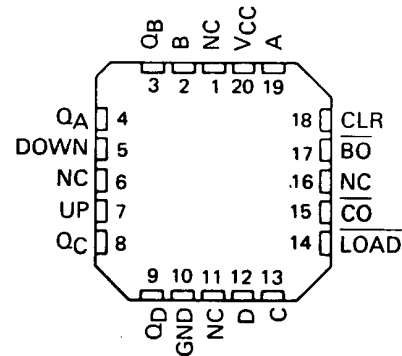

NC - No internal connection

## absolute maximum ratings over operating free-air temperature range (unless otherwise noted)

	SN54'	SN54LS'	SN74'	SN74LS'	UNIT
Supply voltage, $V_{CC}$ (see Note 1)	7	7	7	7	V
Input voltage	5.5	7	5.5	7	V
Operating free-air temperature range	-55 to 125		0 to 70		°C
Storage temperature range	-65 to 150		-65 to 150		°C

NOTE 1: Voltage values are with respect to network ground terminal.

PRODUCTION DATA information is current as of publication date. Products conform to specifications per the terms of Texas Instruments standard warranty. Production processing does not necessarily include testing of all parameters.



POST OFFICE BOX 655303 • DALLAS, TEXAS 75265

Copyright © 1988, Texas Instruments Incorporated

# SN54192, SN54LS192, SN74192, SN74LS192 SYNCHRONOUS 4-BIT UP/DOWN COUNTERS (DUAL CLOCK WITH CLEAR)

SDLS074 – DECEMBER 1972 – REVISED MARCH 1988

logic diagram (positive logic)

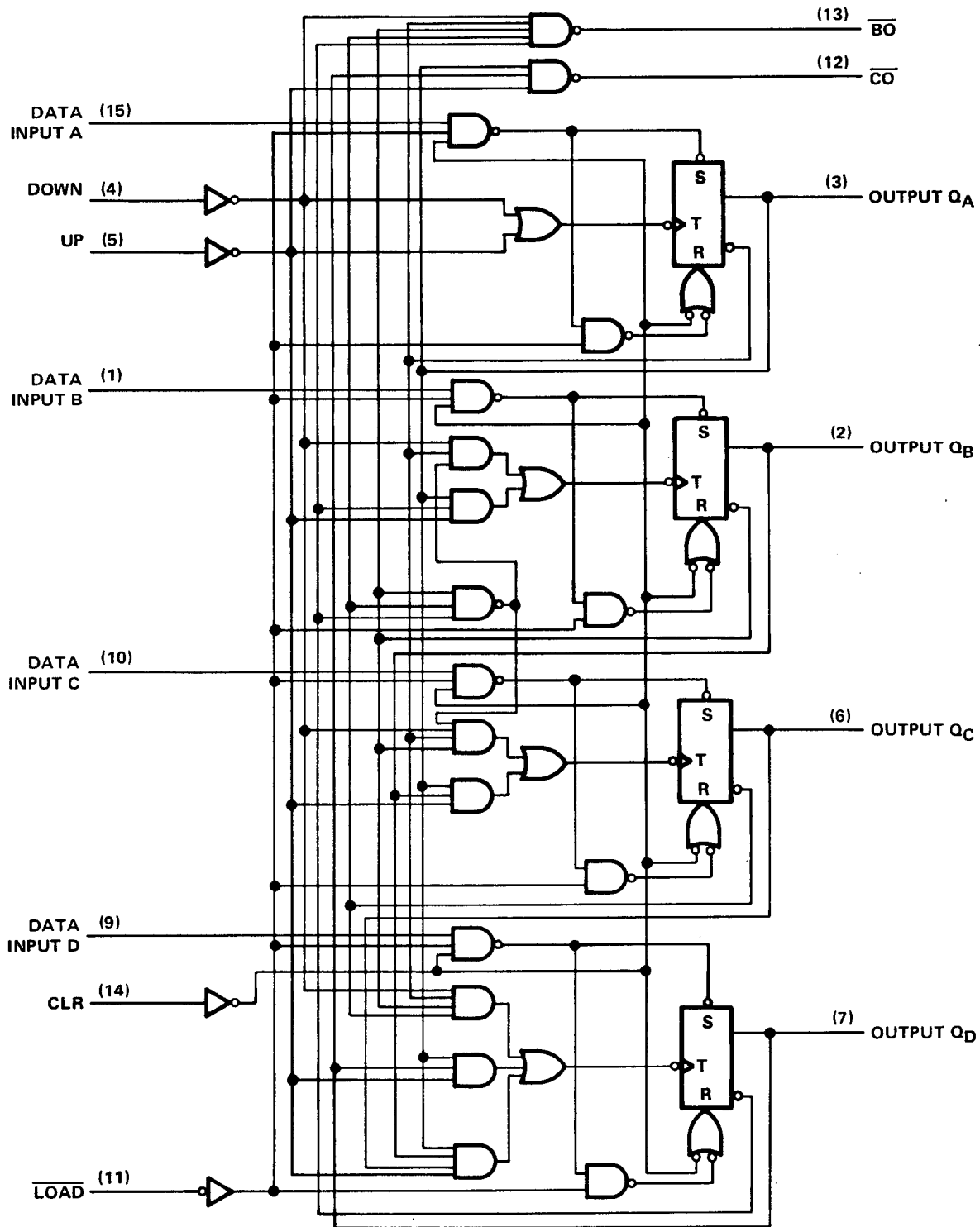

Pin numbers shown are for D, J, N, and W packages.



POST OFFICE BOX 655303 • DALLAS, TEXAS 75265

# SN54193, SN54LS193, SN74193, SN74LS193 SYNCHRONOUS 4-BIT UP/DOWN COUNTERS (DUAL CLOCK WITH CLEAR)

SDLS074 - DECEMBER 1972 - REVISED MARCH 1988

logic diagram (positive logic)

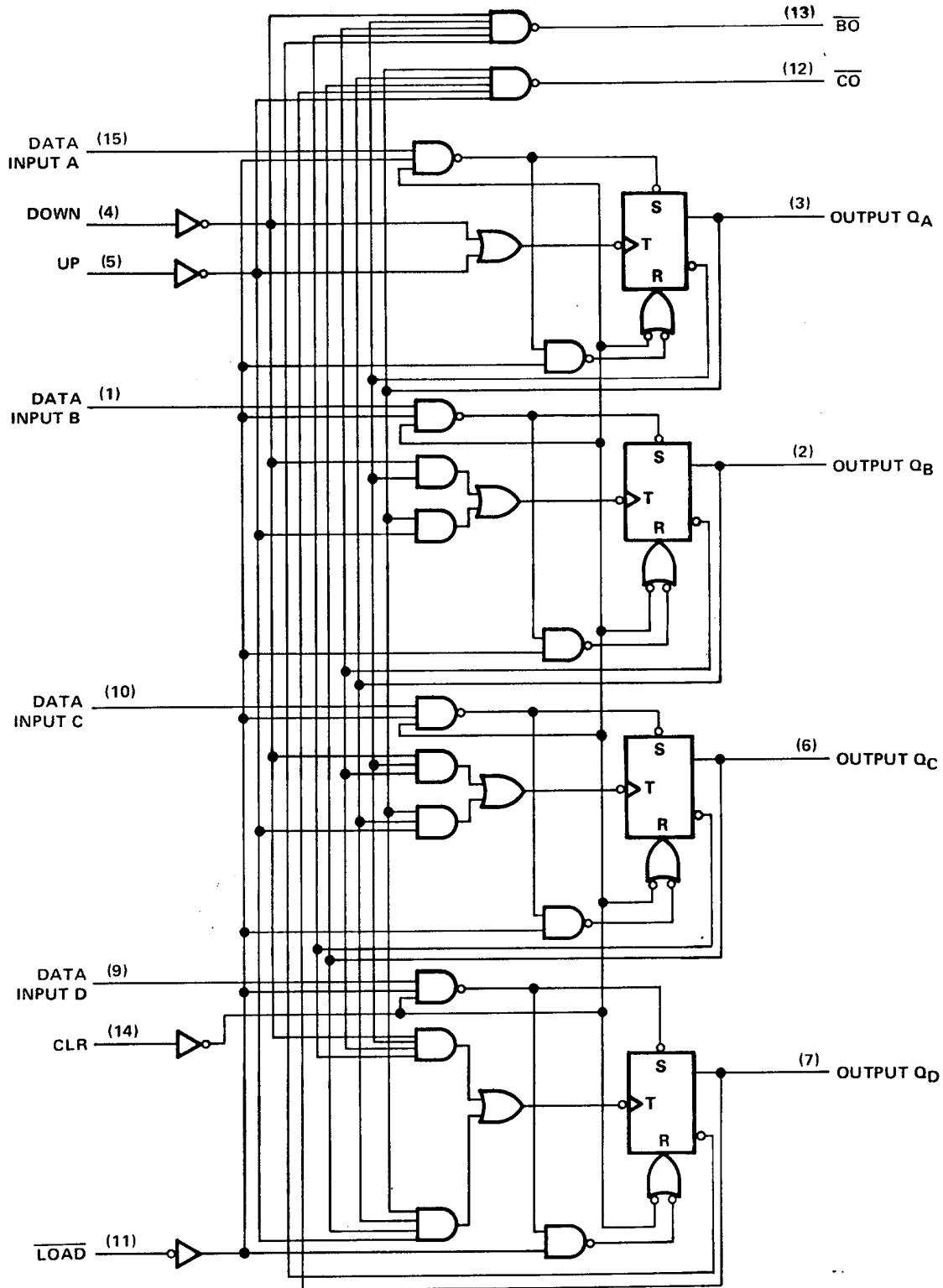

Pin numbers shown are for D, J, N, and W packages.



POST OFFICE BOX 655303 • DALLAS, TEXAS 75265

**SN54192, SN54193, SN54LS192, SN54LS193,  
SN74192, SN74193, SN74LS192, SN74LS193  
SYNCHRONOUS 4-BIT UP/DOWN COUNTERS (DUAL CLOCK WITH CLEAR)**

SDLS074 - DECEMBER 1972 - REVISED MARCH 1988

logic symbols†

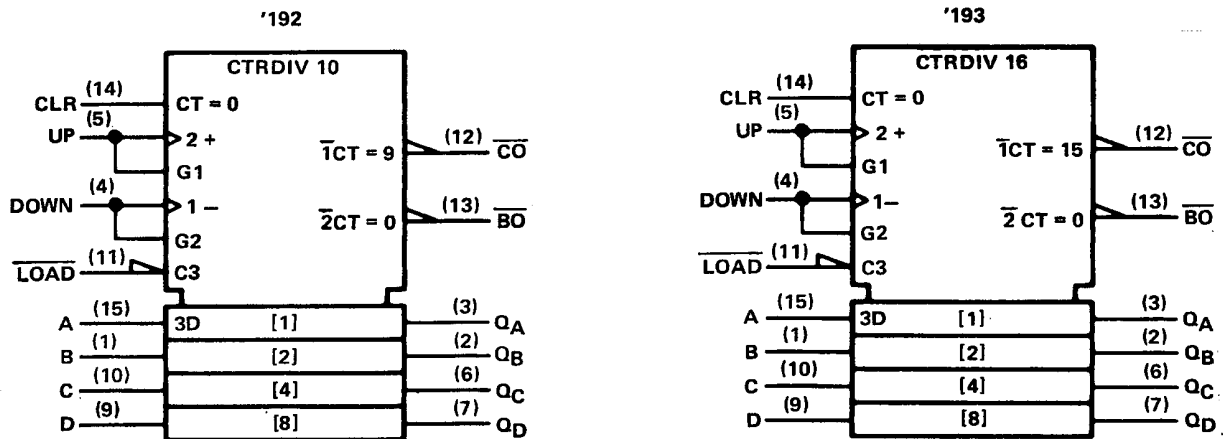

†These symbols are in accordance with ANSI/IEEE Std. 91-1984 and IEC Publication 617-12.

Pin numbers shown are for D, J, N, and W packages.

schematics of inputs and outputs

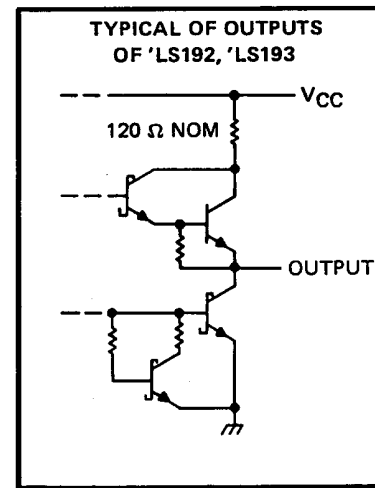
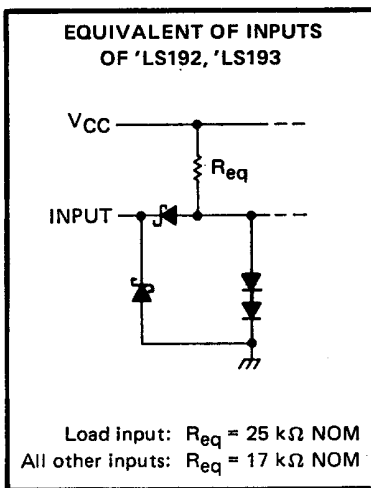
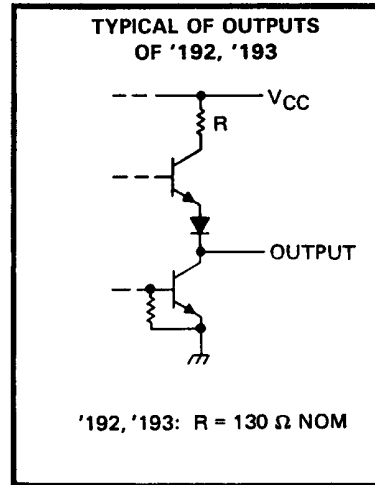
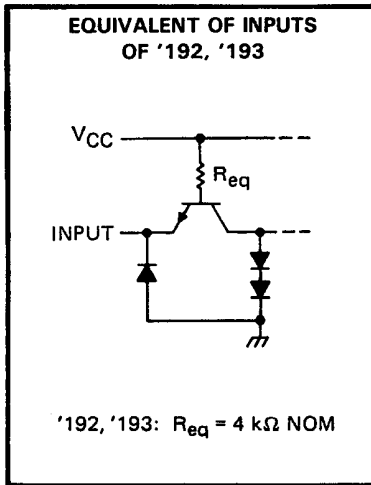

# SN54192, SN54LS192, SN74192, SN74LS192 SYNCHRONOUS 4-BIT UP/DOWN COUNTERS (DUAL CLOCK WITH CLEAR)

SDLS074 - DECEMBER 1972 - REVISED MARCH 1988

## '192, 'LS192 DECADE COUNTERS

### typical clear, load, and count sequences

Illustrated below is the following sequence:

1. Clear outputs to zero.
2. Load (preset) to BCD seven.
3. Count up to eight, nine, carry, zero, one, and two.
4. Count down to one, zero, borrow, nine, eight, and seven.

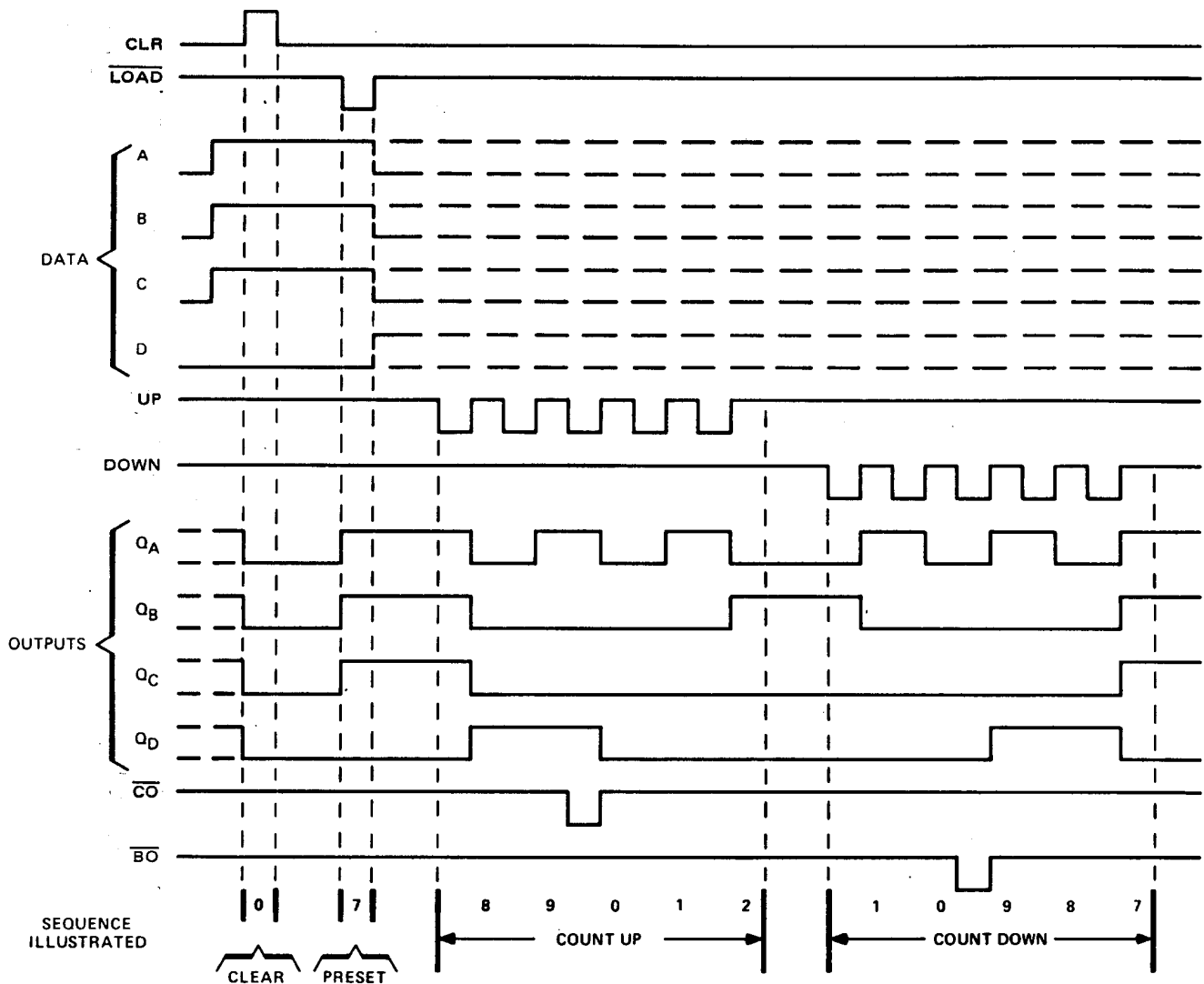

NOTES: A. Clear overrides load, data, and count inputs.

B. When counting up, count-down input must be high; when counting down, count-up input must be high.



# SN54193, SN54LS193, SN74193, SN74LS193 SYNCHRONOUS 4-BIT UP/DOWN COUNTERS (DUAL CLOCK WITH CLEAR)

SDLS074 – DECEMBER 1972 – REVISED MARCH 1988

## '193, 'LS193 BINARY COUNTERS

### typical clear, load, and count sequences

Illustrated below is the following sequence:

1. Clear outputs to zero.
2. Load (preset) to binary thirteen.
3. Count up to fourteen, fifteen, carry, zero, one, and two.
4. Count down to one, zero, borrow, fifteen, fourteen, and thirteen.

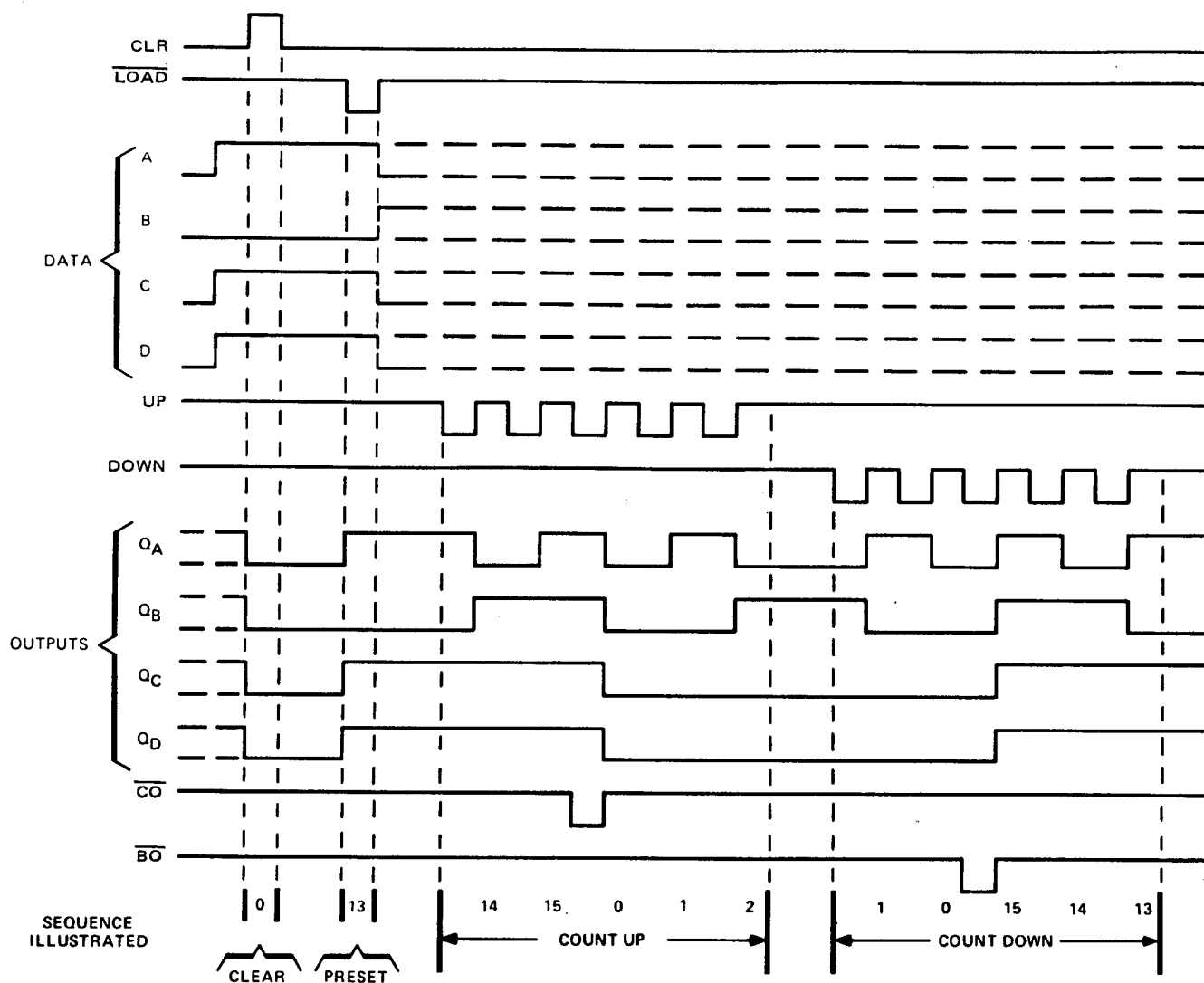

NOTES: A. Clear overrides load, data, and count inputs.

B. When counting up, count-down input must be high; when counting down, count-up input must be high.



POST OFFICE BOX 655303 • DALLAS, TEXAS 75265

# SN54192, SN54193, SN74192, SN74193 SYNCHRONOUS 4-BIT UP/DOWN COUNTERS (DUAL CLOCK WITH CLEAR)

SDLS074 - DECEMBER 1972 - REVISED MARCH 1988

## recommended operating conditions

		SN54192 SN54193			SN74192 SN74193			UNIT
		MIN	NOM	MAX	MIN	NOM	MAX	
V <sub>CC</sub>	Supply voltage	4.5	5	5.5	4.75	5	5.25	V
I <sub>OH</sub>	High-level output current			-0.4			-0.4	mA
I <sub>OL</sub>	Low-level output current			16			16	mA
f <sub>clock</sub>	Clock frequency	0		25	0		25	MHz
t <sub>w</sub>	Width of any input pulse	20			20			ns
t <sub>su</sub>	Data setup time, (see Figure 1)	20			20			ns
t <sub>h</sub>	Hold time	Data, high or low			0			ns
		LOAD			3			
T <sub>A</sub>	Operating free-air temperature	-55		125	0		70	°C

## electrical characteristics over recommended operating free-air temperature range (unless otherwise noted)

PARAMETER	TEST CONDITIONS†	SN54192 SN54193			SN74192 SN74193			UNIT	
		MIN	TYP‡	MAX	MIN	TYP‡	MAX		
V <sub>IH</sub>	High-level input voltage		2			2		V	
V <sub>IL</sub>	Low-level input voltage			0.8			0.8	V	
V <sub>IK</sub>	Input clamp voltage	V <sub>CC</sub> = MIN, I <sub>I</sub> = -12 mA					-1.5	V	
V <sub>OH</sub>	High-level output voltage	V <sub>CC</sub> = MIN, V <sub>IH</sub> = 2 V, V <sub>IL</sub> = 0.8 V, I <sub>OH</sub> = -0.4 mA			2.4	3.4		2.4 3.4	V
V <sub>OL</sub>	Low-level output voltage	V <sub>CC</sub> = MIN, V <sub>IH</sub> = 2 V, V <sub>IL</sub> = 0.8 V, I <sub>OL</sub> = 16 mA				0.2 0.4		0.2 0.4	V
I <sub>I</sub>	Input current at maximum input voltage	V <sub>CC</sub> = MAX, V <sub>I</sub> = 5.5 V					1	1	mA
I <sub>IH</sub>	High-level input current	V <sub>CC</sub> = MAX, V <sub>I</sub> = 2.4 V					40	40	μA
I <sub>IL</sub>	Low-level input current	V <sub>CC</sub> = MAX, V <sub>I</sub> = 0.4 V					-1.6	-1.6	mA
I <sub>OS</sub>	Short-circuit output current§	V <sub>CC</sub> = MAX			-20		-65	-18 -65	mA
I <sub>CC</sub>	Supply current	V <sub>CC</sub> = MAX, See Note 2				65 89		65 102	mA

† For conditions shown as MIN or MAX, use the appropriate value specified under recommended operating conditions for the applicable type.

‡ All typical values are at V<sub>CC</sub> = 5 V, T<sub>A</sub> = 25°C.

§ Not more than one output should be shorted at a time.

NOTE 2: I<sub>CC</sub> is measured with all outputs open, clear and load inputs grounded, and all other inputs at 4.5 V.

## switching characteristics, V<sub>CC</sub> = 5 V, T<sub>A</sub> = 25°C

PARAMETER¶	FROM INPUT	TO OUTPUT	TEST CONDITIONS	MIN	TYP	MAX	UNIT
f <sub>max</sub>			C <sub>L</sub> = 15 pF, R <sub>L</sub> = 400 Ω, See Figures 1 and 2	25	32		MHz
t <sub>PLH</sub>	UP	$\overline{CO}$			17	26	ns
t <sub>PHL</sub>					16	24	
t <sub>PLH</sub>	DOWN	$\overline{BO}$			16	24	ns
t <sub>PHL</sub>					16	24	
t <sub>PLH</sub>	UP OR DOWN	Q			25	38	ns
t <sub>PHL</sub>					31	47	
t <sub>PLH</sub>	$\overline{LOAD}$	Q			27	40	ns
t <sub>PHL</sub>					29	40	
t <sub>PHL</sub>	CLR	Q			22	35	ns

¶ f<sub>max</sub> ≡ maximum clock frequency

t<sub>PLH</sub> ≡ propagation delay time, low-to-high-level output

t<sub>PHL</sub> ≡ propagation delay time, high-to-low-level output



# SN54LS192, SN54LS193, SN74LS192, SN74LS193 SYNCHRONOUS 4-BIT UP/DOWN COUNTERS (DUAL CLOCK WITH CLEAR)

SDLS074 – DECEMBER 1972 – REVISED MARCH 1988

## recommended operating conditions

		SN54LS192 SN54LS193			SN74LS192 SN74LS193			UNIT
		MIN	NOM	MAX	MIN	NOM	MAX	
V <sub>CC</sub>	Supply voltage	4.5	5	5.5	4.75	5	5.25	V
I <sub>OH</sub>	High-level output current			-400			-400	μA
I <sub>OL</sub>	Low-level output current			4			8	mA
f <sub>clock</sub>	Clock frequency	0		25	0		25	MHz
t <sub>w</sub>	Width of any input pulse	20			20			ns
t <sub>su</sub>	Clear inactive-state setup time	15			15			ns
	Load inactive-state setup time	15			15			ns
	Data setup time (see Figure 1)	20			20			ns
t <sub>h</sub>	Data hold time	5			5			ns
T <sub>A</sub>	Operating free-air temperature range	-55		125	0		70	°C

## electrical characteristics over recommended operating free-air temperature range (unless otherwise noted)

PARAMETER	TEST CONDITIONS†	SN54LS192 SN54LS193			SN74LS192 SN74LS193			UNIT	
		MIN	TYP‡	MAX	MIN	TYP‡	MAX		
V <sub>IH</sub>	High-level input voltage	2			2			V	
V <sub>IL</sub>	Low-level input voltage			0.7			0.8	V	
V <sub>IK</sub>	Input clamp voltage	V <sub>CC</sub> = MIN, I <sub>I</sub> = -18 mA		-1.5			-1.5	V	
V <sub>OH</sub>	High-level output voltage	V <sub>CC</sub> = MIN, V <sub>IH</sub> = 2 V, V <sub>IL</sub> = V <sub>IL max</sub> , I <sub>OH</sub> = -400 μA		2.5	3.4		2.7	3.4	V
V <sub>OL</sub>	Low-level output voltage	V <sub>CC</sub> = MIN, V <sub>IH</sub> = 2 V, V <sub>IL</sub> = V <sub>IL max</sub>		I <sub>OL</sub> = 4 mA	0.25	0.4	0.15	0.4	V
		I <sub>OL</sub> = 8 mA			0.35	0.5			
I <sub>I</sub>	Input current at maximum input voltage	V <sub>CC</sub> = MAX, V <sub>I</sub> = 7 V		0.1		0.1		mA	
I <sub>IH</sub>	High-level input current	V <sub>CC</sub> = MAX, V <sub>I</sub> = 2.7 V		20		20		μA	
I <sub>IL</sub>	Low-level input current	V <sub>CC</sub> = MAX, V <sub>I</sub> = 0.4 V		-0.4		-0.4		mA	
I <sub>OS</sub>	Short-circuit output current§	V <sub>CC</sub> = MAX		-20	-100	-20	-100	mA	
I <sub>CC</sub>	Supply current	V <sub>CC</sub> = MAX, See Note 2		19	34	19	34	mA	

† For conditions shown as MIN or MAX, use the appropriate value specified under recommended operating conditions for the applicable type.

‡ All typical values are at V<sub>CC</sub> = 5 V, T<sub>A</sub> = 25°C.

§ Not more than one output should be shorted at a time, and duration of the short-circuit should not exceed one second.

NOTE 2: I<sub>CC</sub> is measured with all outputs open, clear and load inputs grounded, and all other inputs at 4.5 V.

## switching characteristics, V<sub>CC</sub> = 5 V, T<sub>A</sub> = 25°C

PARAMETER	FROM INPUT	TO OUTPUT	TEST CONDITIONS	MIN	TYP	MAX	UNIT
f <sub>max</sub>			C <sub>L</sub> = 15 pF, R <sub>L</sub> = 2 kΩ, See Figures 1 and 2	25	32		MHz
t <sub>PLH</sub>	UP	$\overline{CO}$			17	26	ns
t <sub>PHL</sub>					18	24	
t <sub>PLH</sub>	DOWN	$\overline{BO}$			16	24	ns
t <sub>PHL</sub>					15	24	
t <sub>PLH</sub>	UP OR DOWN	Q			27	38	ns
t <sub>PHL</sub>					30	47	
t <sub>PLH</sub>	$\overline{LOAD}$	Q			24	40	ns
t <sub>PHL</sub>					25	40	
t <sub>PHL</sub>	CLR	Q			23	35	ns



**SN54192, SN54193, SN54LS192, SN54LS193,  
SN74192, SN74193, SN74LS192, SN74LS193**  
**SYNCHRONOUS 4-BIT UP/DOWN COUNTERS (DUAL CLOCK WITH CLEAR)**

SDLS074 - DECEMBER 1972 - REVISED MARCH 1988

**PARAMETER MEASUREMENT INFORMATION**

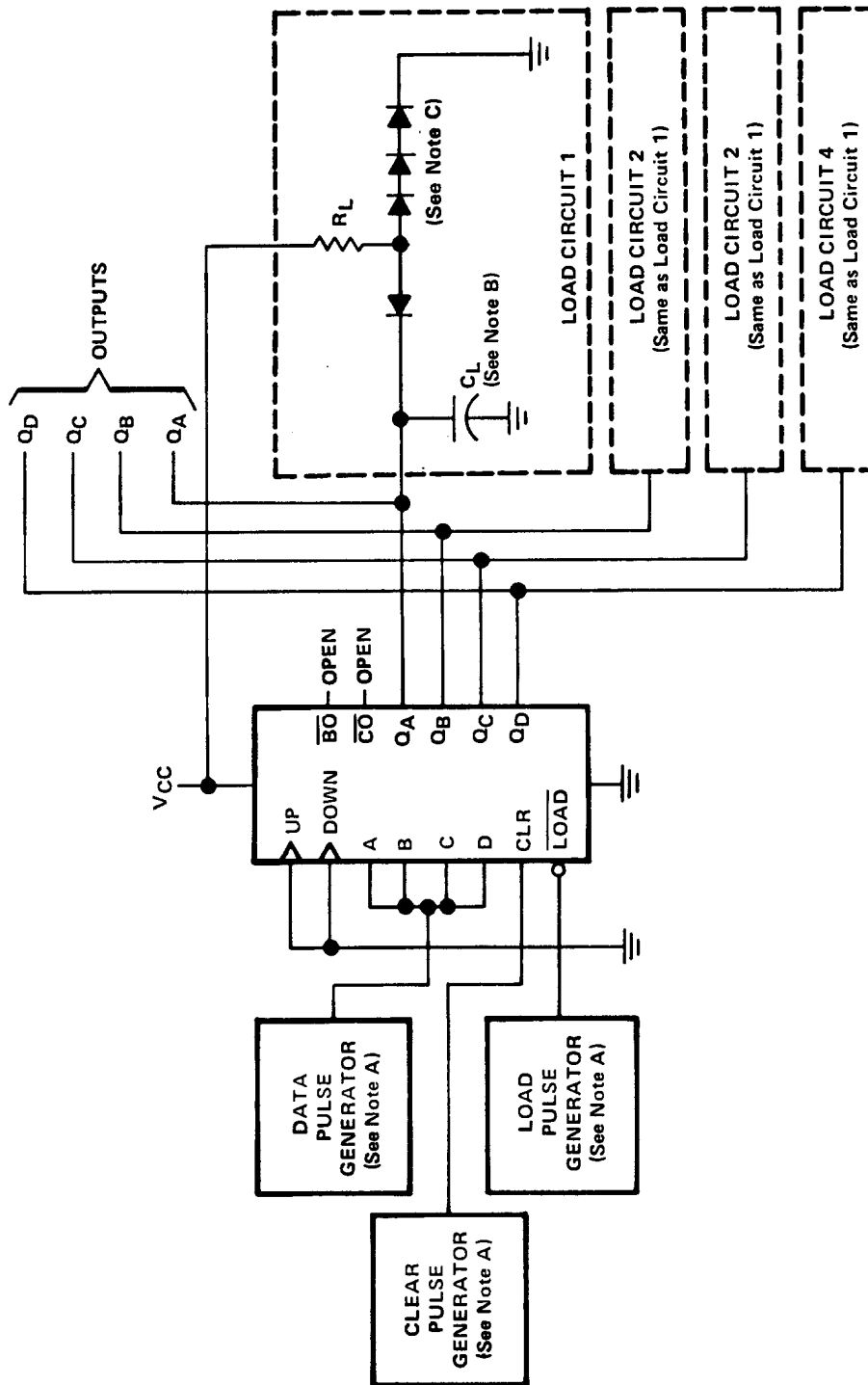

**TEST CIRCUIT**

- NOTES:**
- A. The pulse generators have the following characteristics:  $Z_{out} \approx 50 \Omega$  and for the data pulse generator  $PRR \leq 500 \text{ kHz}$ , duty cycle = 50%; for the load pulse generator  $PRR$  is two times data  $PRR$ , duty cycle = 50%.
  - B.  $C_L$  includes probe and jig capacitance.
  - C. Diodes are 1N3064 or equivalent.
  - D.  $t_r$  and  $t_f \leq 7 \text{ ns}$ .
  - E.  $V_{ref}$  is 1.5 V for '192 and '193, 1.3 V for 'LS192 and 'LS193.

**FIGURE 1A - CLEAR, SETUP AND LOAD TIMES**

**SN54192, SN54193, SN54LS192, SN54LS193,  
SN74192, SN74193, SN74LS192, SN74LS193  
SYNCHRONOUS 4-BIT UP/DOWN COUNTERS (DUAL CLOCK WITH CLEAR)**  
SDLS074 - DECEMBER 1972 - REVISED MARCH 1988

**PARAMETER MEASUREMENT INFORMATION**

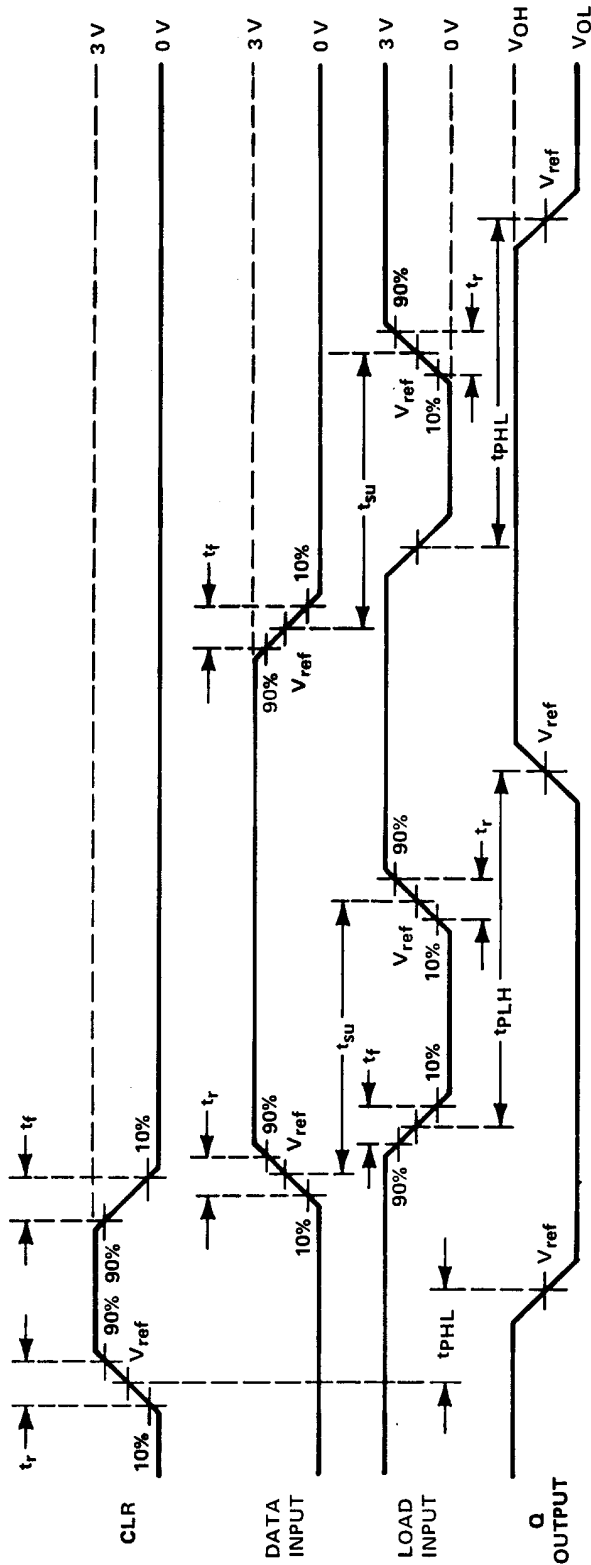

**VOLTAGE WAVEFORMS**

- NOTES:**
- A. The pulse generators have the following characteristics:  $Z_{out} \approx 50 \Omega$  and for the data pulse generator PRR  $\leq 500$  kHz, duty cycle = 50%; for the load pulse generator PRR is two times data PRR, duty cycle = 50%
  - B.  $C_L$  includes probe and jig capacitance.
  - C. Diodes are 1N3064 or equivalent.
  - D.  $t_r$  and  $t_f \leq 7$  ns.
  - E.  $V_{ref}$  is 1.5 V for '192 and '193, 1.3 V for 'LS192 and 'LS193.

**FIGURE 1B - CLEAR, SETUP, AND LOAD TIMES**

**SN54192, SN54193, SN54LS192, SN54LS193,  
SN74192, SN74193, SN74LS192, SN74LS193**  
**SYNCHRONOUS 4-BIT UP/DOWN COUNTERS (DUAL CLOCK WITH CLEAR)**

SDLS074 - DECEMBER 1972 - REVISED MARCH 1988

**PARAMETER MEASUREMENT INFORMATION**

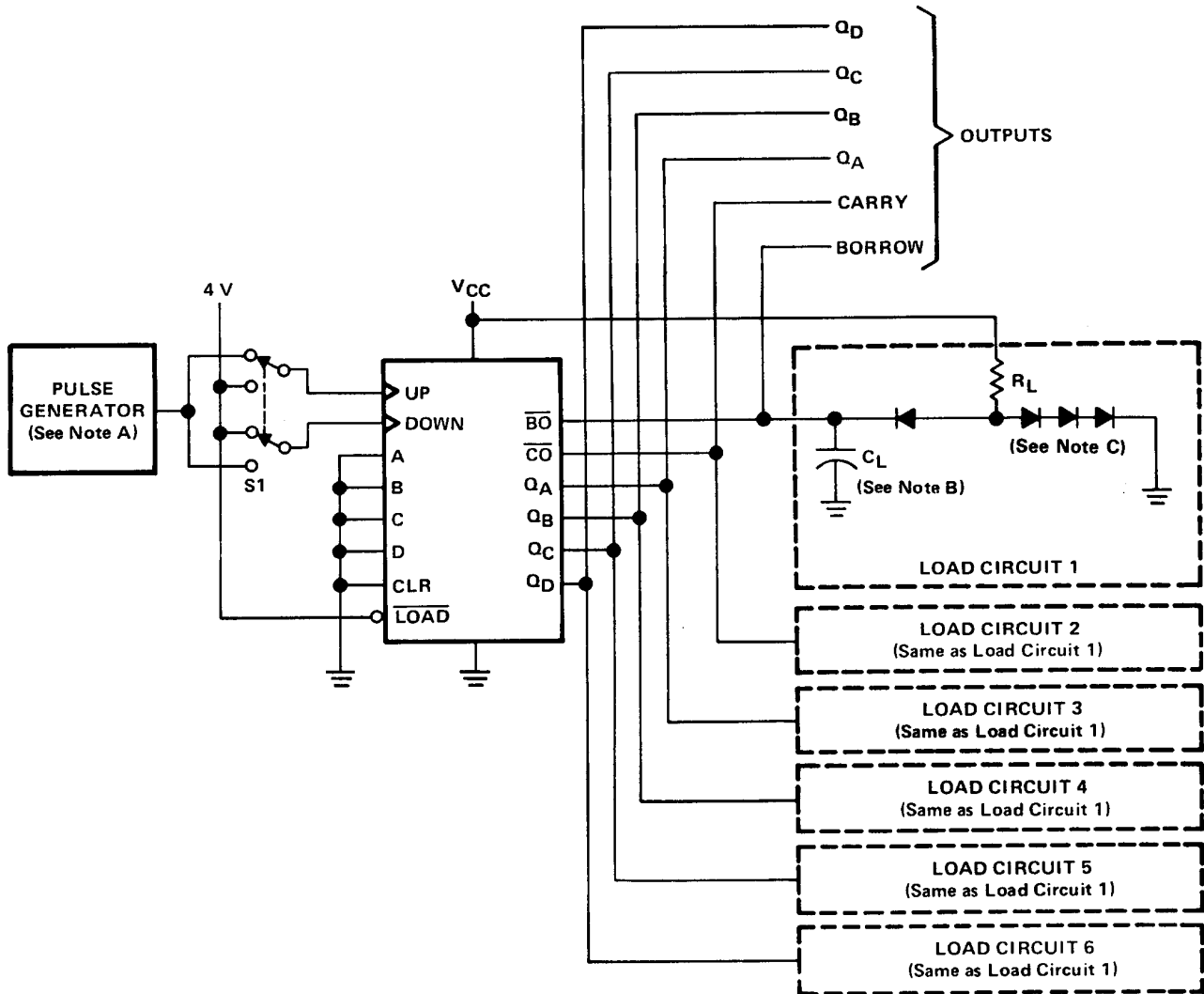

**TEST CIRCUIT**

- NOTES:**
- A. The pulse generators have the following characteristics:  $PRR \approx 1 \text{ MHz}$ ,  $Z_{out} \approx 50 \Omega$ , duty cycle = 50%.
  - B.  $C_L$  includes probe and jig capacitance.
  - C. Diodes are 1N3064 or equivalent.
  - D. Count-up and count-down pulse shown are for the '193 and 'LS193 binary counters. Count cycle for '192 and 'LS192 decade counters is 1 through 10.
  - E. Waveforms for outputs  $Q_A$ ,  $Q_B$ , and  $Q_C$  are omitted to simplify the drawing.
  - F.  $t_r$  and  $t_f \leq 7 \text{ ns}$ .
  - G.  $V_{ref}$  is 1.5 V for '192 and '193, 1.3 V for 'LS192 and 'LS193.

**FIGURE 2A - PROPAGATION DELAY TIMES**

**SN54192, SN54193, SN54LS192, SN54LS193,  
SN74192, SN74193, SN74LS192, SN74LS193  
SYNCHRONOUS 4-BIT UP/DOWN COUNTERS (DUAL CLOCK WITH CLEAR)**

SDLS074 - DECEMBER 1972 - REVISED MARCH 1988

**PARAMETER MEASUREMENT INFORMATION**

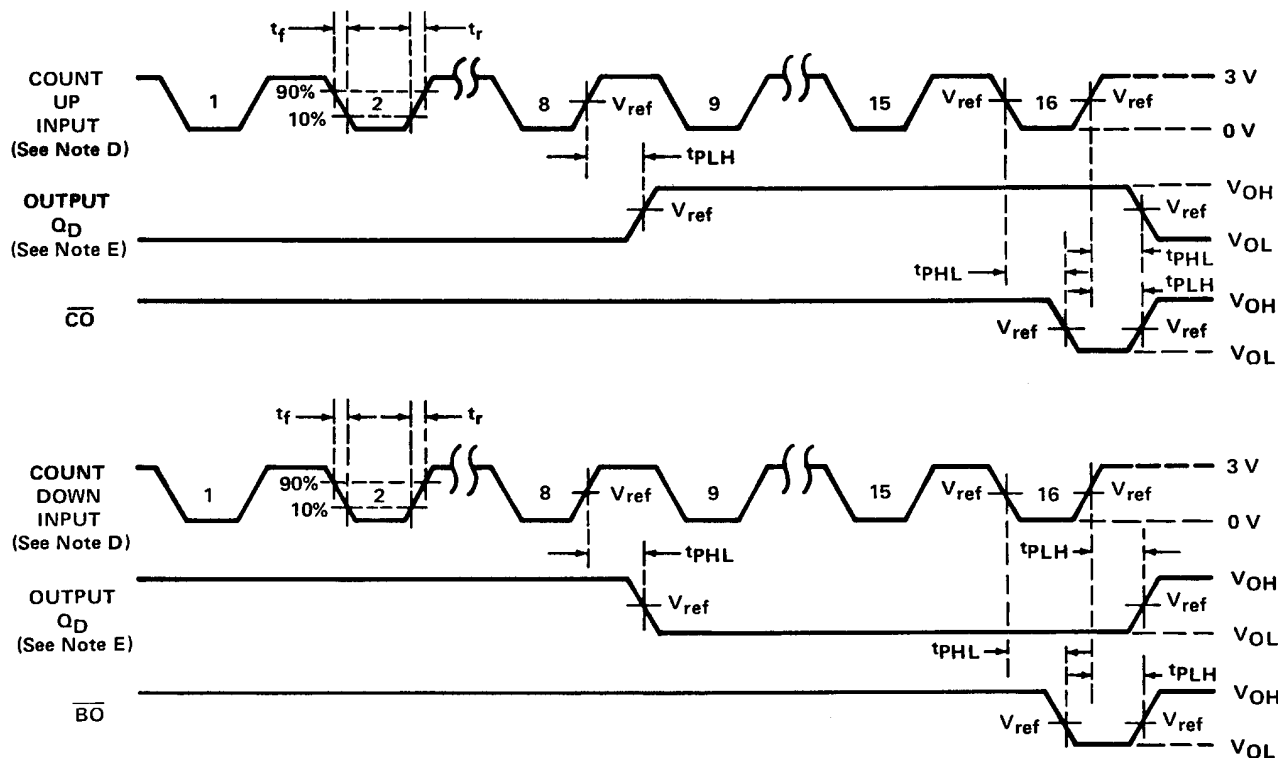

**VOLTAGE WAVEFORMS**

- NOTES: A. The pulse generators have the following characteristics: PRR  $\approx$  1 MHz,  $Z_{out} \approx 50 \Omega$ , duty cycle = 50%.  
 B.  $C_L$  includes probe and jig capacitance.  
 C. Diodes are 1N3064 or equivalent.  
 D. Count-up and count-down pulse shown are for the '193 and 'LS193 binary counters. Count cycle for '192 and 'LS192 decade counters is 1 through 10.  
 E. Waveforms for outputs  $Q_A$ ,  $Q_B$ , and  $Q_C$  are omitted to simplify the drawing.  
 F.  $t_r$  and  $t_f \leq 7$  ns.  
 G.  $V_{ref}$  is 1.5 V for '192 and '193, 1.3 V for 'LS192 and 'LS193.

**FIGURE 2B - PROPAGATION DELAY TIMES**

**PACKAGING INFORMATION**

Orderable Device	Status (1)	Package Type	Package Drawing	Pins	Package Qty	Eco Plan (2)	Lead finish/ Ball material (6)	MSL Peak Temp (3)	Op Temp (°C)	Device Marking (4/5)	Samples
5962-9558401QEA	ACTIVE	CDIP	J	16	25	Non-RoHS & Green	SNPB	N / A for Pkg Type	-55 to 125	5962-9558401QE A SNJ54192J	<a href="#">Samples</a>
5962-9558401QFA	ACTIVE	CFP	W	16	25	Non-RoHS & Green	SNPB	N / A for Pkg Type	-55 to 125	5962-9558401QF A SNJ54192W	<a href="#">Samples</a>
5962-9558401QFA	ACTIVE	CFP	W	16	25	Non-RoHS & Green	SNPB	N / A for Pkg Type	-55 to 125	5962-9558401QF A SNJ54192W	<a href="#">Samples</a>
76006012A	ACTIVE	LCCC	FK	20	55	Non-RoHS & Green	SNPB	N / A for Pkg Type	-55 to 125	76006012A SNJ54LS 193FK	<a href="#">Samples</a>
76006012A	ACTIVE	LCCC	FK	20	55	Non-RoHS & Green	SNPB	N / A for Pkg Type	-55 to 125	76006012A SNJ54LS 193FK	<a href="#">Samples</a>
7600601EA	ACTIVE	CDIP	J	16	25	Non-RoHS & Green	SNPB	N / A for Pkg Type	-55 to 125	7600601EA SNJ54LS193J	<a href="#">Samples</a>
7600601EA	ACTIVE	CDIP	J	16	25	Non-RoHS & Green	SNPB	N / A for Pkg Type	-55 to 125	7600601EA SNJ54LS193J	<a href="#">Samples</a>
7600601FA	ACTIVE	CFP	W	16	25	Non-RoHS & Green	SNPB	N / A for Pkg Type	-55 to 125	7600601FA SNJ54LS193W	<a href="#">Samples</a>
7600601FA	ACTIVE	CFP	W	16	25	Non-RoHS & Green	SNPB	N / A for Pkg Type	-55 to 125	7600601FA SNJ54LS193W	<a href="#">Samples</a>
JM38510/31508B2A	ACTIVE	LCCC	FK	20	55	Non-RoHS & Green	SNPB	N / A for Pkg Type	-55 to 125	JM38510/ 31508B2A	<a href="#">Samples</a>
JM38510/31508B2A	ACTIVE	LCCC	FK	20	55	Non-RoHS & Green	SNPB	N / A for Pkg Type	-55 to 125	JM38510/ 31508B2A	<a href="#">Samples</a>
JM38510/31508BEA	ACTIVE	CDIP	J	16	25	Non-RoHS & Green	SNPB	N / A for Pkg Type	-55 to 125	JM38510/ 31508BEA	<a href="#">Samples</a>
JM38510/31508BEA	ACTIVE	CDIP	J	16	25	Non-RoHS & Green	SNPB	N / A for Pkg Type	-55 to 125	JM38510/ 31508BEA	<a href="#">Samples</a>
JM38510/31508BFA	ACTIVE	CFP	W	16	25	Non-RoHS & Green	SNPB	N / A for Pkg Type	-55 to 125	JM38510/ 31508BFA	<a href="#">Samples</a>

Orderable Device	Status (1)	Package Type	Package Drawing	Pins	Package Qty	Eco Plan (2)	Lead finish/ Ball material (6)	MSL Peak Temp (3)	Op Temp (°C)	Device Marking (4/5)	Samples
JM38510/31508BFA	ACTIVE	CFP	W	16	25	Non-RoHS & Green	SNPB	N / A for Pkg Type	-55 to 125	JM38510/ 31508BFA	<a href="#">Samples</a>
JM38510/31508SFA	ACTIVE	CFP	W	16	25	Non-RoHS & Green	SNPB	N / A for Pkg Type	-55 to 125	JM38510/ 31508SFA	<a href="#">Samples</a>
JM38510/31508SFA	ACTIVE	CFP	W	16	25	Non-RoHS & Green	SNPB	N / A for Pkg Type	-55 to 125	JM38510/ 31508SFA	<a href="#">Samples</a>
M38510/31508B2A	ACTIVE	LCCC	FK	20	55	Non-RoHS & Green	SNPB	N / A for Pkg Type	-55 to 125	JM38510/ 31508B2A	<a href="#">Samples</a>
M38510/31508B2A	ACTIVE	LCCC	FK	20	55	Non-RoHS & Green	SNPB	N / A for Pkg Type	-55 to 125	JM38510/ 31508B2A	<a href="#">Samples</a>
M38510/31508BEA	ACTIVE	CDIP	J	16	25	Non-RoHS & Green	SNPB	N / A for Pkg Type	-55 to 125	JM38510/ 31508BEA	<a href="#">Samples</a>
M38510/31508BEA	ACTIVE	CDIP	J	16	25	Non-RoHS & Green	SNPB	N / A for Pkg Type	-55 to 125	JM38510/ 31508BEA	<a href="#">Samples</a>
M38510/31508BFA	ACTIVE	CFP	W	16	25	Non-RoHS & Green	SNPB	N / A for Pkg Type	-55 to 125	JM38510/ 31508BFA	<a href="#">Samples</a>
M38510/31508BFA	ACTIVE	CFP	W	16	25	Non-RoHS & Green	SNPB	N / A for Pkg Type	-55 to 125	JM38510/ 31508BFA	<a href="#">Samples</a>
M38510/31508SFA	ACTIVE	CFP	W	16	25	Non-RoHS & Green	SNPB	N / A for Pkg Type	-55 to 125	JM38510/ 31508SFA	<a href="#">Samples</a>
M38510/31508SFA	ACTIVE	CFP	W	16	25	Non-RoHS & Green	SNPB	N / A for Pkg Type	-55 to 125	JM38510/ 31508SFA	<a href="#">Samples</a>
SN54192J	ACTIVE	CDIP	J	16	25	Non-RoHS & Green	SNPB	N / A for Pkg Type	-55 to 125	SN54192J	<a href="#">Samples</a>
SN54192J	ACTIVE	CDIP	J	16	25	Non-RoHS & Green	SNPB	N / A for Pkg Type	-55 to 125	SN54192J	<a href="#">Samples</a>
SN54LS193J	ACTIVE	CDIP	J	16	25	Non-RoHS & Green	SNPB	N / A for Pkg Type	-55 to 125	SN54LS193J	<a href="#">Samples</a>
SN54LS193J	ACTIVE	CDIP	J	16	25	Non-RoHS & Green	SNPB	N / A for Pkg Type	-55 to 125	SN54LS193J	<a href="#">Samples</a>
SN74LS193DR	ACTIVE	SOIC	D	16	2500	RoHS & Green	NIPDAU	Level-1-260C-UNLIM	0 to 70	LS193	<a href="#">Samples</a>
SN74LS193DR	ACTIVE	SOIC	D	16	2500	RoHS & Green	NIPDAU	Level-1-260C-UNLIM	0 to 70	LS193	<a href="#">Samples</a>
SN74LS193N	ACTIVE	PDIP	N	16	25	RoHS & Green	NIPDAU	N / A for Pkg Type	0 to 70	SN74LS193N	<a href="#">Samples</a>

Orderable Device	Status (1)	Package Type	Package Drawing	Pins	Package Qty	Eco Plan (2)	Lead finish/ Ball material (6)	MSL Peak Temp (3)	Op Temp (°C)	Device Marking (4/5)	Samples
SN74LS193N	ACTIVE	PDIP	N	16	25	RoHS & Green	NIPDAU	N / A for Pkg Type	0 to 70	SN74LS193N	<a href="#">Samples</a>
SN74LS193NE4	ACTIVE	PDIP	N	16	25	RoHS & Green	NIPDAU	N / A for Pkg Type	0 to 70	SN74LS193N	<a href="#">Samples</a>
SN74LS193NE4	ACTIVE	PDIP	N	16	25	RoHS & Green	NIPDAU	N / A for Pkg Type	0 to 70	SN74LS193N	<a href="#">Samples</a>
SN74LS193NSR	ACTIVE	SO	NS	16	2000	RoHS & Green	NIPDAU	Level-1-260C-UNLIM	0 to 70	74LS193	<a href="#">Samples</a>
SN74LS193NSR	ACTIVE	SO	NS	16	2000	RoHS & Green	NIPDAU	Level-1-260C-UNLIM	0 to 70	74LS193	<a href="#">Samples</a>
SNJ54192J	ACTIVE	CDIP	J	16	25	Non-RoHS & Green	SNPB	N / A for Pkg Type	-55 to 125	5962-9558401QE A SNJ54192J	<a href="#">Samples</a>
SNJ54192J	ACTIVE	CDIP	J	16	25	Non-RoHS & Green	SNPB	N / A for Pkg Type	-55 to 125	5962-9558401QE A SNJ54192J	<a href="#">Samples</a>
SNJ54192W	ACTIVE	CFP	W	16	25	Non-RoHS & Green	SNPB	N / A for Pkg Type	-55 to 125	5962-9558401QF A SNJ54192W	<a href="#">Samples</a>
SNJ54192W	ACTIVE	CFP	W	16	25	Non-RoHS & Green	SNPB	N / A for Pkg Type	-55 to 125	5962-9558401QF A SNJ54192W	<a href="#">Samples</a>
SNJ54LS193FK	ACTIVE	LCCC	FK	20	55	Non-RoHS & Green	SNPB	N / A for Pkg Type	-55 to 125	76006012A SNJ54LS 193FK	<a href="#">Samples</a>
SNJ54LS193FK	ACTIVE	LCCC	FK	20	55	Non-RoHS & Green	SNPB	N / A for Pkg Type	-55 to 125	76006012A SNJ54LS 193FK	<a href="#">Samples</a>
SNJ54LS193J	ACTIVE	CDIP	J	16	25	Non-RoHS & Green	SNPB	N / A for Pkg Type	-55 to 125	7600601EA SNJ54LS193J	<a href="#">Samples</a>
SNJ54LS193J	ACTIVE	CDIP	J	16	25	Non-RoHS & Green	SNPB	N / A for Pkg Type	-55 to 125	7600601EA SNJ54LS193J	<a href="#">Samples</a>
SNJ54LS193W	ACTIVE	CFP	W	16	25	Non-RoHS & Green	SNPB	N / A for Pkg Type	-55 to 125	7600601FA SNJ54LS193W	<a href="#">Samples</a>
SNJ54LS193W	ACTIVE	CFP	W	16	25	Non-RoHS & Green	SNPB	N / A for Pkg Type	-55 to 125	7600601FA SNJ54LS193W	<a href="#">Samples</a>

<sup>(1)</sup> The marketing status values are defined as follows:

**ACTIVE:** Product device recommended for new designs.

**LIFEBUY:** TI has announced that the device will be discontinued, and a lifetime-buy period is in effect.

**NRND:** Not recommended for new designs. Device is in production to support existing customers, but TI does not recommend using this part in a new design.

**PREVIEW:** Device has been announced but is not in production. Samples may or may not be available.

**OBSOLETE:** TI has discontinued the production of the device.

<sup>(2)</sup> **RoHS:** TI defines "RoHS" to mean semiconductor products that are compliant with the current EU RoHS requirements for all 10 RoHS substances, including the requirement that RoHS substance do not exceed 0.1% by weight in homogeneous materials. Where designed to be soldered at high temperatures, "RoHS" products are suitable for use in specified lead-free processes. TI may reference these types of products as "Pb-Free".

**RoHS Exempt:** TI defines "RoHS Exempt" to mean products that contain lead but are compliant with EU RoHS pursuant to a specific EU RoHS exemption.

**Green:** TI defines "Green" to mean the content of Chlorine (Cl) and Bromine (Br) based flame retardants meet JS709B low halogen requirements of <=1000ppm threshold. Antimony trioxide based flame retardants must also meet the <=1000ppm threshold requirement.

<sup>(3)</sup> MSL, Peak Temp. - The Moisture Sensitivity Level rating according to the JEDEC industry standard classifications, and peak solder temperature.

<sup>(4)</sup> There may be additional marking, which relates to the logo, the lot trace code information, or the environmental category on the device.

<sup>(5)</sup> Multiple Device Markings will be inside parentheses. Only one Device Marking contained in parentheses and separated by a "~" will appear on a device. If a line is indented then it is a continuation of the previous line and the two combined represent the entire Device Marking for that device.

<sup>(6)</sup> Lead finish/Ball material - Orderable Devices may have multiple material finish options. Finish options are separated by a vertical ruled line. Lead finish/Ball material values may wrap to two lines if the finish value exceeds the maximum column width.

**Important Information and Disclaimer:**The information provided on this page represents TI's knowledge and belief as of the date that it is provided. TI bases its knowledge and belief on information provided by third parties, and makes no representation or warranty as to the accuracy of such information. Efforts are underway to better integrate information from third parties. TI has taken and continues to take reasonable steps to provide representative and accurate information but may not have conducted destructive testing or chemical analysis on incoming materials and chemicals. TI and TI suppliers consider certain information to be proprietary, and thus CAS numbers and other limited information may not be available for release.

In no event shall TI's liability arising out of such information exceed the total purchase price of the TI part(s) at issue in this document sold by TI to Customer on an annual basis.

**OTHER QUALIFIED VERSIONS OF SN54LS193, SN54LS193-SP, SN74LS193 :**

● Catalog : [SN74LS193](#), [SN54LS193](#)

● Military : [SN54LS193](#)

● Space : [SN54LS193-SP](#)

NOTE: Qualified Version Definitions:

- Catalog - TI's standard catalog product
- Military - QML certified for Military and Defense Applications
- Space - Radiation tolerant, ceramic packaging and qualified for use in Space-based application

**TAPE AND REEL INFORMATION**

**QUADRANT ASSIGNMENTS FOR PIN 1 ORIENTATION IN TAPE**



\*All dimensions are nominal

Device	Package Type	Package Drawing	Pins	SPQ	Reel Diameter (mm)	Reel Width W1 (mm)	A0 (mm)	B0 (mm)	K0 (mm)	P1 (mm)	W (mm)	Pin1 Quadrant
SN74LS193DR	SOIC	D	16	2500	330.0	16.4	6.5	10.3	2.1	8.0	16.0	Q1
SN74LS193NSR	SO	NS	16	2000	330.0	16.4	8.2	10.5	2.5	12.0	16.0	Q1
SN74LS193NSR	SO	NS	16	2000	330.0	16.4	8.2	10.5	2.5	12.0	16.0	Q1

**TAPE AND REEL BOX DIMENSIONS**

\*All dimensions are nominal

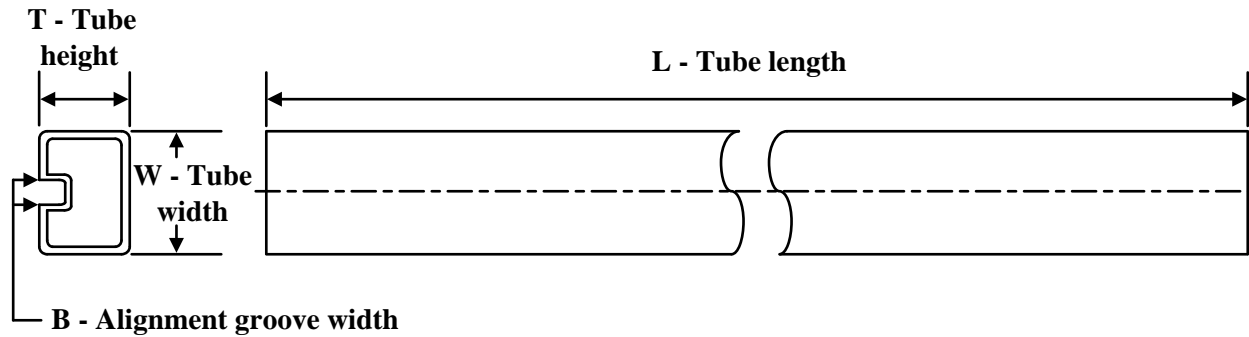
Device	Package Type	Package Drawing	Pins	SPQ	Length (mm)	Width (mm)	Height (mm)
SN74LS193DR	SOIC	D	16	2500	340.5	336.1	32.0
SN74LS193NSR	SO	NS	16	2000	356.0	356.0	35.0
SN74LS193NSR	SO	NS	16	2000	356.0	356.0	35.0

**TUBE**

\*All dimensions are nominal

Device	Package Name	Package Type	Pins	SPQ	L (mm)	W (mm)	T (µm)	B (mm)
5962-9558401QFA	W	CFP	16	25	506.98	26.16	6220	NA
76006012A	FK	LCCC	20	55	506.98	12.06	2030	NA
76006012A	FK	LCCC	20	55	506.98	12.06	2030	NA
7600601FA	W	CFP	16	25	506.98	26.16	6220	NA
7600601FA	W	CFP	16	25	506.98	26.16	6220	NA
JM38510/31508B2A	FK	LCCC	20	55	506.98	12.06	2030	NA
JM38510/31508B2A	FK	LCCC	20	55	506.98	12.06	2030	NA
JM38510/31508BFA	W	CFP	16	25	506.98	26.16	6220	NA
JM38510/31508BFA	W	CFP	16	25	506.98	26.16	6220	NA
JM38510/31508SFA	W	CFP	16	25	506.98	26.16	6220	NA
JM38510/31508SFA	W	CFP	16	25	506.98	26.16	6220	NA
M38510/31508B2A	FK	LCCC	20	55	506.98	12.06	2030	NA
M38510/31508B2A	FK	LCCC	20	55	506.98	12.06	2030	NA
M38510/31508BFA	W	CFP	16	25	506.98	26.16	6220	NA
M38510/31508BFA	W	CFP	16	25	506.98	26.16	6220	NA
M38510/31508SFA	W	CFP	16	25	506.98	26.16	6220	NA
M38510/31508SFA	W	CFP	16	25	506.98	26.16	6220	NA
SN74LS193N	N	PDIP	16	25	506	13.97	11230	4.32
SN74LS193N	N	PDIP	16	25	506	13.97	11230	4.32
SN74LS193N	N	PDIP	16	25	506	13.97	11230	4.32
SN74LS193N	N	PDIP	16	25	506	13.97	11230	4.32
SN74LS193NE4	N	PDIP	16	25	506	13.97	11230	4.32
SN74LS193NE4	N	PDIP	16	25	506	13.97	11230	4.32
SN74LS193NE4	N	PDIP	16	25	506	13.97	11230	4.32
SN74LS193NE4	N	PDIP	16	25	506	13.97	11230	4.32
SNJ54192W	W	CFP	16	25	506.98	26.16	6220	NA
SNJ54192W	W	CFP	16	25	506.98	26.16	6220	NA
SNJ54LS193FK	FK	LCCC	20	55	506.98	12.06	2030	NA
SNJ54LS193FK	FK	LCCC	20	55	506.98	12.06	2030	NA

---

Device	Package Name	Package Type	Pins	SPQ	L (mm)	W (mm)	T (μm)	B (mm)
SNJ54LS193W	W	CFP	16	25	506.98	26.16	6220	NA
SNJ54LS193W	W	CFP	16	25	506.98	26.16	6220	NA



# PACKAGE OUTLINE

## NS0016A

### SOP - 2.00 mm max height

SOP

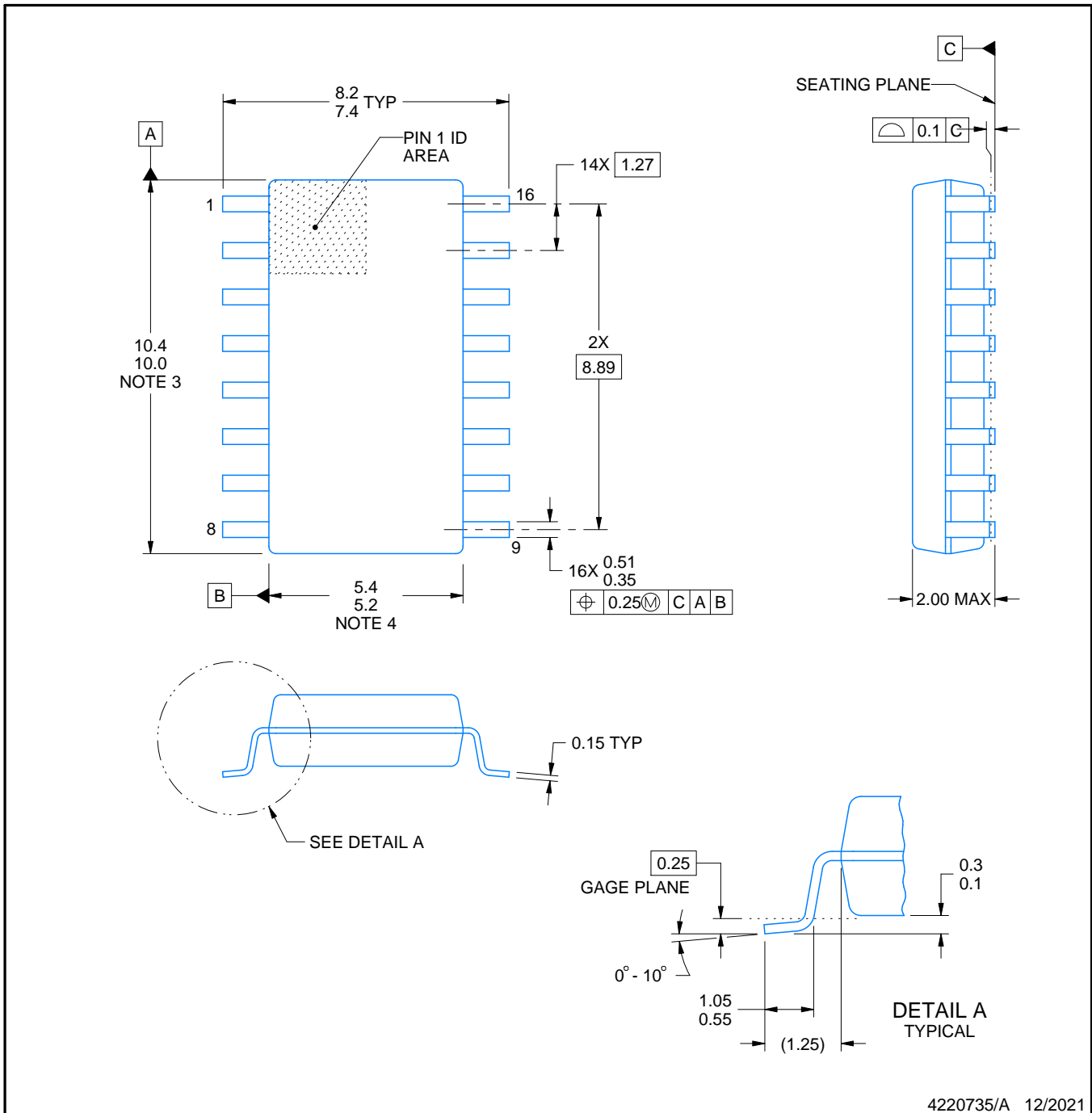

4220735/A 12/2021

#### NOTES:

1. All linear dimensions are in millimeters. Dimensions in parenthesis are for reference only. Dimensioning and tolerancing per ASME Y14.5M.
2. This drawing is subject to change without notice.
3. This dimension does not include mold flash, protrusions, or gate burrs. Mold flash, protrusions, or gate burrs shall not exceed 0.15 mm, per side.
4. This dimension does not include interlead flash. Interlead flash shall not exceed 0.25 mm, per side.

# EXAMPLE BOARD LAYOUT

NS0016A

SOP - 2.00 mm max height

SOP



4220735/A 12/2021

NOTES: (continued)

5. Publication IPC-7351 may have alternate designs.

6. Solder mask tolerances between and around signal pads can vary based on board fabrication site.

# EXAMPLE STENCIL DESIGN

NS0016A

SOP - 2.00 mm max height

SOP

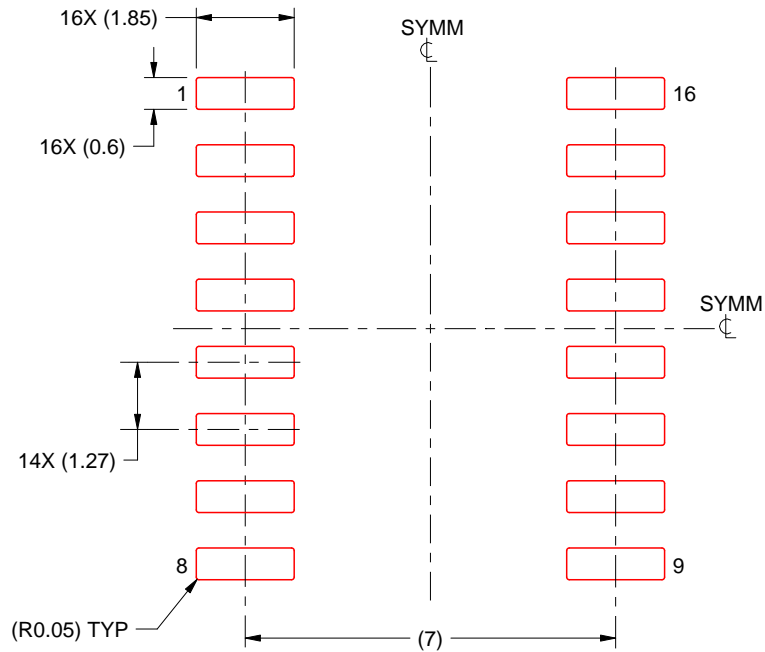

SOLDER PASTE EXAMPLE  
BASED ON 0.125 mm THICK STENCIL  
SCALE:7X

4220735/A 12/2021

NOTES: (continued)

7. Laser cutting apertures with trapezoidal walls and rounded corners may offer better paste release. IPC-7525 may have alternate design recommendations.
8. Board assembly site may have different recommendations for stencil design.

D (R-PDSO-G16)

PLASTIC SMALL OUTLINE

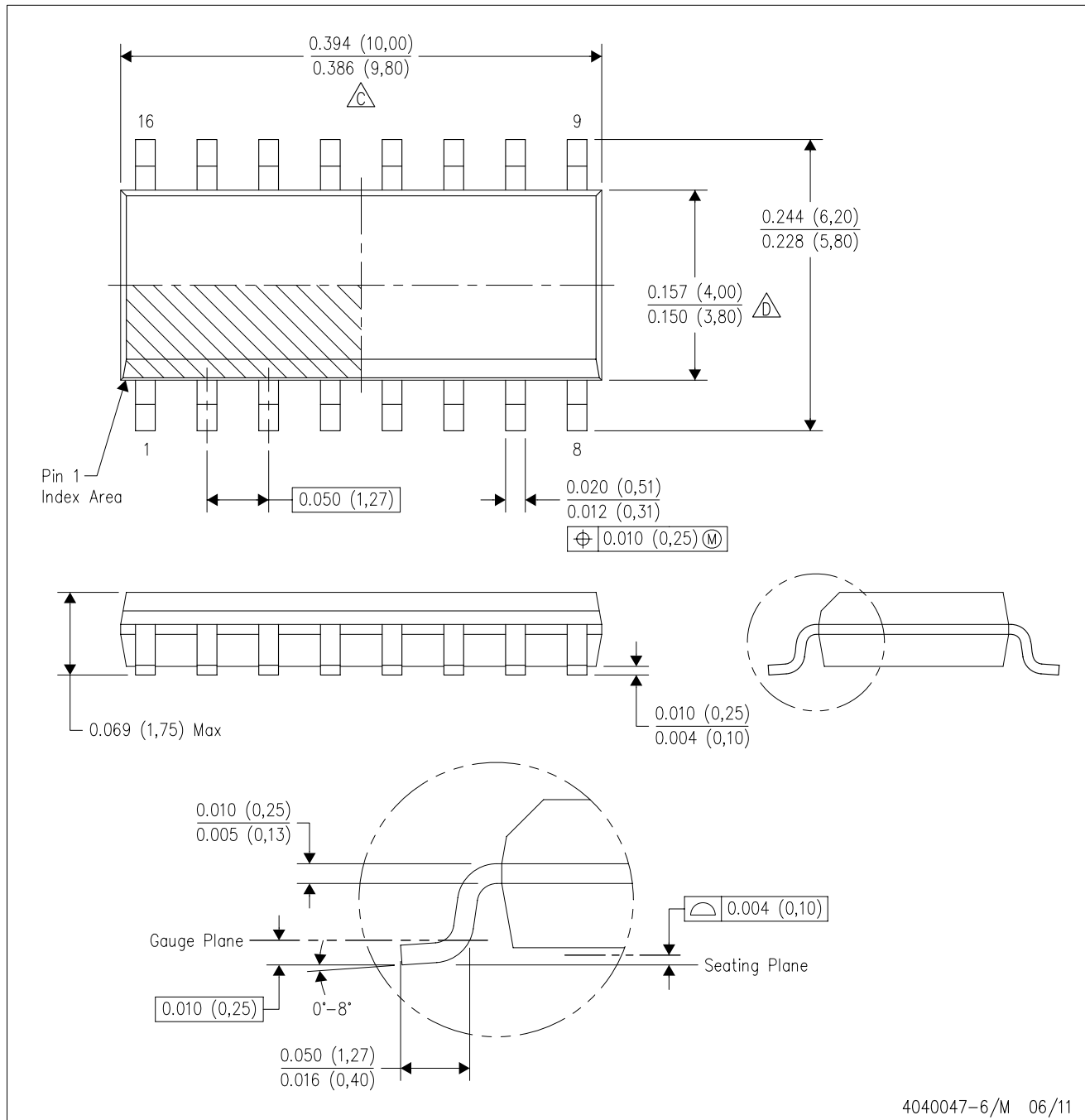

- NOTES:
- A. All linear dimensions are in inches (millimeters).
  - B. This drawing is subject to change without notice.
  - C. Body length does not include mold flash, protrusions, or gate burrs. Mold flash, protrusions, or gate burrs shall not exceed 0.006 (0,15) each side.
  - D. Body width does not include interlead flash. Interlead flash shall not exceed 0.017 (0,43) each side.
  - E. Reference JEDEC MS-012 variation AC.

D (R-PDSO-G16)

PLASTIC SMALL OUTLINE



- NOTES:
- All linear dimensions are in millimeters.
  - This drawing is subject to change without notice.
  - Publication IPC-7351 is recommended for alternate designs.
  - Laser cutting apertures with trapezoidal walls and also rounding corners will offer better paste release. Customers should contact their board assembly site for stencil design recommendations. Refer to IPC-7525 for other stencil recommendations.
  - Customers should contact their board fabrication site for solder mask tolerances between and around signal pads.

## MECHANICAL DATA

NS (R-PDSO-G\*\*)

PLASTIC SMALL-OUTLINE PACKAGE

14-PINS SHOWN



- NOTES:
- A. All linear dimensions are in millimeters.
  - B. This drawing is subject to change without notice.
  - C. Body dimensions do not include mold flash or protrusion, not to exceed 0,15.

W (R-GDFP-F16)

CERAMIC DUAL FLATPACK

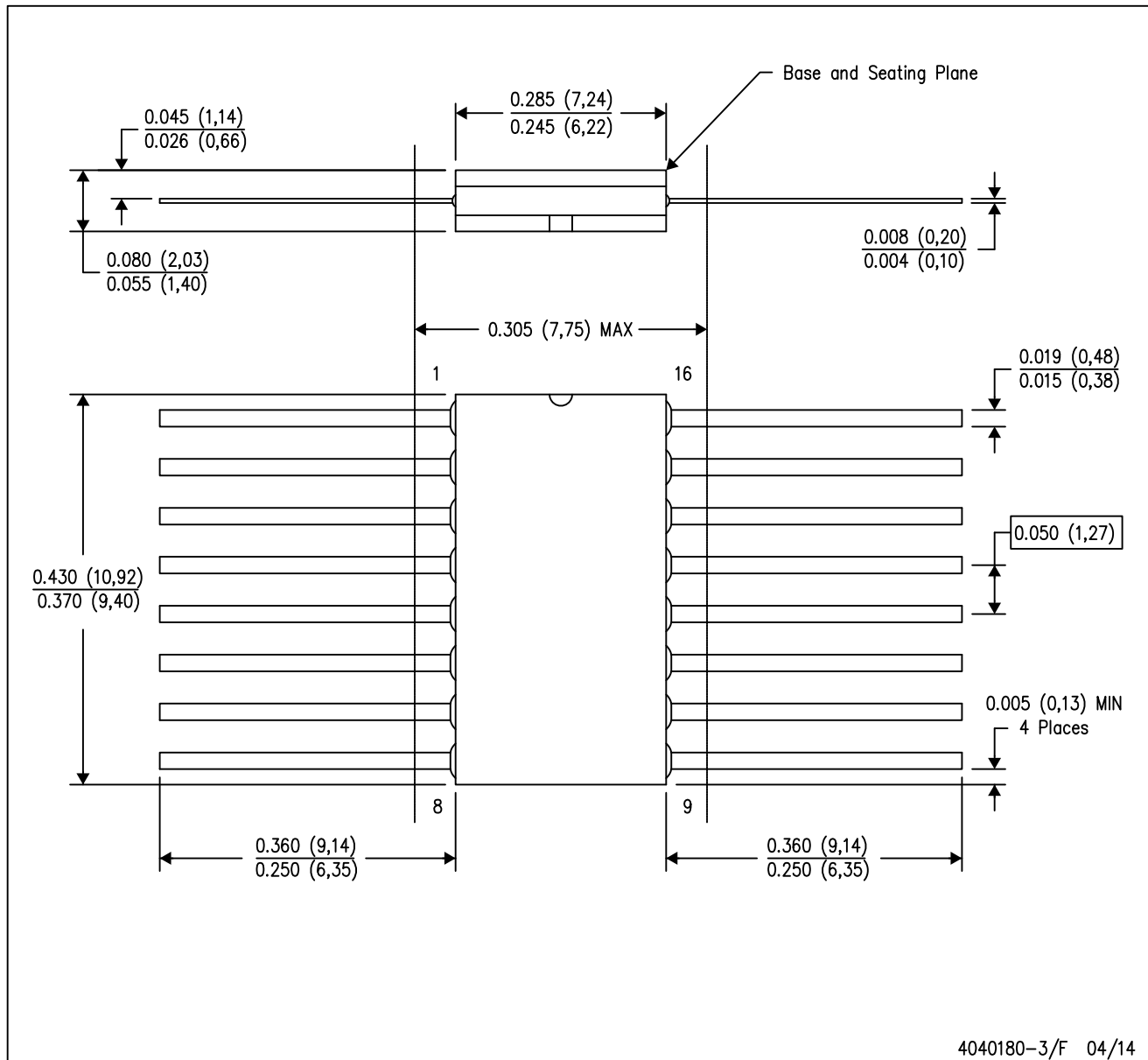

- NOTES:
- A. All linear dimensions are in inches (millimeters).
  - B. This drawing is subject to change without notice.
  - C. This package can be hermetically sealed with a ceramic lid using glass frit.
  - D. Index point is provided on cap for terminal identification only.
  - E. Falls within MIL STD 1835 GDFP2-F16

## GENERIC PACKAGE VIEW

**FK 20**

**LCCC - 2.03 mm max height**

8.89 x 8.89, 1.27 mm pitch

LEADLESS CERAMIC CHIP CARRIER

This image is a representation of the package family, actual package may vary.  
Refer to the product data sheet for package details.

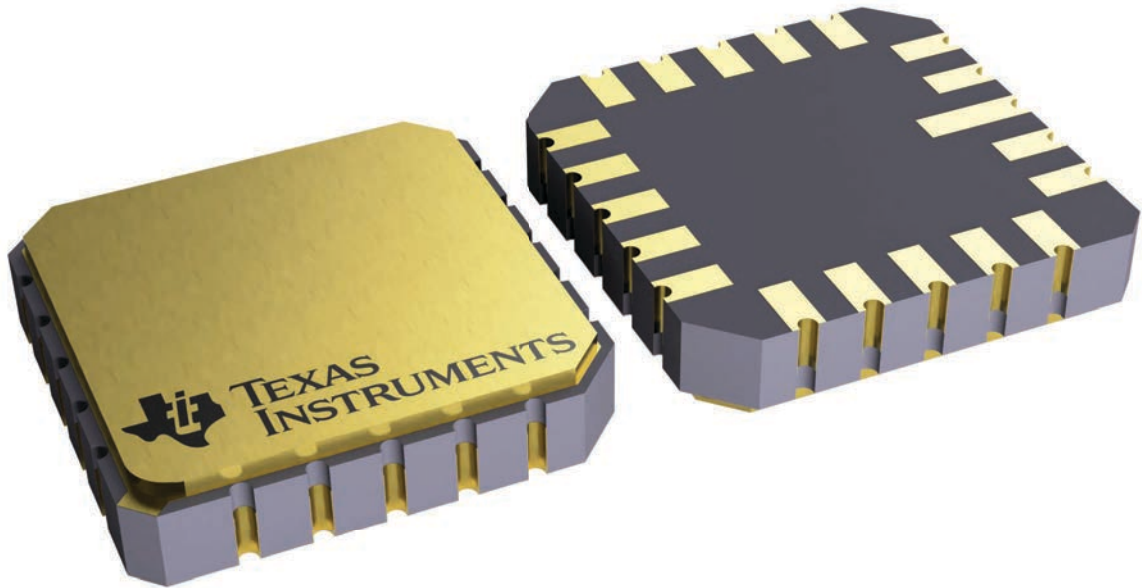

4229370VA\

# J (R-GDIP-T\*\*)

14 LEADS SHOWN

# CERAMIC DUAL IN-LINE PACKAGE



DIM \ PINS **	14	16	18	20
A	0.300 (7,62) BSC	0.300 (7,62) BSC	0.300 (7,62) BSC	0.300 (7,62) BSC
B MAX	0.785 (19,94)	.840 (21,34)	0.960 (24,38)	1.060 (26,92)
B MIN	—	—	—	—
C MAX	0.300 (7,62)	0.300 (7,62)	0.310 (7,87)	0.300 (7,62)
C MIN	0.245 (6,22)	0.245 (6,22)	0.220 (5,59)	0.245 (6,22)



4040083/F 03/03

- NOTES:
- All linear dimensions are in inches (millimeters).
  - This drawing is subject to change without notice.
  - This package is hermetically sealed with a ceramic lid using glass frit.
  - Index point is provided on cap for terminal identification only on press ceramic glass frit seal only.
  - Falls within MIL STD 1835 GDIP1-T14, GDIP1-T16, GDIP1-T18 and GDIP1-T20.

N (R-PDIP-T\*\*)

PLASTIC DUAL-IN-LINE PACKAGE

16 PINS SHOWN



4040049/E 12/2002

- NOTES:
- A. All linear dimensions are in inches (millimeters).
  - B. This drawing is subject to change without notice.
  - (C) Falls within JEDEC MS-001, except 18 and 20 pin minimum body length (Dim A).
  - (D) The 20 pin end lead shoulder width is a vendor option, either half or full width.

## IMPORTANT NOTICE AND DISCLAIMER

TI PROVIDES TECHNICAL AND RELIABILITY DATA (INCLUDING DATA SHEETS), DESIGN RESOURCES (INCLUDING REFERENCE DESIGNS), APPLICATION OR OTHER DESIGN ADVICE, WEB TOOLS, SAFETY INFORMATION, AND OTHER RESOURCES "AS IS" AND WITH ALL FAULTS, AND DISCLAIMS ALL WARRANTIES, EXPRESS AND IMPLIED, INCLUDING WITHOUT LIMITATION ANY IMPLIED WARRANTIES OF MERCHANTABILITY, FITNESS FOR A PARTICULAR PURPOSE OR NON-INFRINGEMENT OF THIRD PARTY INTELLECTUAL PROPERTY RIGHTS.

These resources are intended for skilled developers designing with TI products. You are solely responsible for (1) selecting the appropriate TI products for your application, (2) designing, validating and testing your application, and (3) ensuring your application meets applicable standards, and any other safety, security, regulatory or other requirements.

These resources are subject to change without notice. TI grants you permission to use these resources only for development of an application that uses the TI products described in the resource. Other reproduction and display of these resources is prohibited. No license is granted to any other TI intellectual property right or to any third party intellectual property right. TI disclaims responsibility for, and you will fully indemnify TI and its representatives against, any claims, damages, costs, losses, and liabilities arising out of your use of these resources.

TI's products are provided subject to [TI's Terms of Sale](#) or other applicable terms available either on [ti.com](https://www.ti.com) or provided in conjunction with such TI products. TI's provision of these resources does not expand or otherwise alter TI's applicable warranties or warranty disclaimers for TI products.

TI objects to and rejects any additional or different terms you may have proposed.

Mailing Address: Texas Instruments, Post Office Box 655303, Dallas, Texas 75265  
Copyright © 2024, Texas Instruments Incorporated

## Looking for pricing, stock, or lifecycle information?

Click below to explore more details on WIN SOURCE:

 [View SNJ54LS193J on WIN SOURCE](#)

 [Texas Instruments](#) Information

## Optimize Your Supply Chain with WIN SOURCE Solutions

-  Global Sourcing Solution
-  Obsolete Management
-  Cost Control Management
-  Shortage Management
-  Alternative Solution
-  Excess Inventory Management