



THE DATASHEET OF PCA9543ADG4



PCA9543A 2-Channel I²C Bus Switch With Interrupt Logic and Reset

1 Features

- 1-of-2 Bidirectional Translating Switches
- I²C Bus and SMBus Compatible
- Two Active-Low Interrupt Inputs
- Active-Low Interrupt Output
- Active-Low Reset Input
- Two Address Pins Allowing up to Four PCA9543A Devices on the I²C Bus
- Channel Selection Via I²C Bus, in Any Combination
- Power-up With All Switch Channels Deselected
- Low R_{ON} Switches
- Allows Voltage-Level Translation Between 1.8-V, 2.5-V, 3.3-V, and 5-V Buses
- No Glitch on Power-up
- Supports Hot Insertion
- Low Standby Current
- Operating Power-Supply Voltage Range of 2.3 V to 5.5 V
- 5.5-V Tolerant Inputs
- 0 to 400-kHz Clock Frequency
- Latch-Up Performance Exceeds 100-mA Per JESD78
- ESD Protection Exceeds JESD 22
 - 2000-V Human-Body Model (A114-A)
 - 1000-V Charged-Device Model (C101)

2 Applications

- Servers
- Routers (Telecom Switching Equipment)
- Factory Automation
- Products With I²C Slave Address Conflicts (For Example, Multiple, Identical Temp Sensors)

3 Description

The PCA9543A is a dual bidirectional translating switch controlled by the I²C bus. The SCL/SDA upstream pair fans out to two downstream pairs, or channels. Either individual SC_n/SD_n channel or both channels can be selected, determined by the contents of the programmable control register. Two interrupt inputs ($\overline{\text{INT}}1$ – $\overline{\text{INT}}0$), one for each of the downstream pairs, are provided. One interrupt output ($\overline{\text{INT}}$) acts as an AND of the two interrupt inputs.

An active-low reset ($\overline{\text{RESET}}$) input allows the PCA9543A to recover from a situation where one of the downstream I²C buses is stuck in a low state. Pulling $\overline{\text{RESET}}$ low resets the I²C state machine and causes both of the channels to be deselected, as does the internal power-on reset function.

The pass gates of the switches are constructed such that the VCC pin can be used to limit the maximum high voltage, which will be passed by the PCA9543A. This allows the use of different bus voltages on each pair, so that 1.8-V, 2.5-V, or 3.3-V parts can communicate with 5-V parts without any additional protection. External pull-up resistors pull the bus up to the desired voltage level for each channel. All I/O pins are 5.5-V tolerant.

Device Information

PART NUMBER	PACKAGE ⁽¹⁾	BODY SIZE (NOM)
PCA9543	TSSOP (14)	5.00 mm × 4.40 mm
	SOIC (14)	8.65 mm × 3.91 mm

(1) For all available packages, see the orderable addendum at the end of the datasheet.

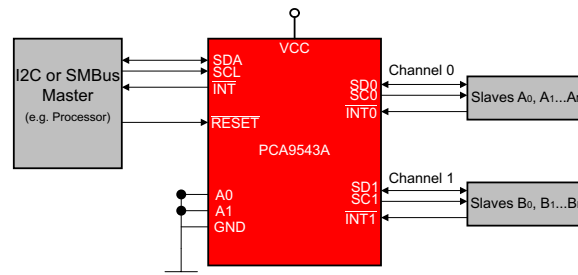

Simplified Application Diagram



Table of Contents

1 Features	1	8.4 Device Functional Modes.....	12
2 Applications	1	8.5 Programming.....	12
3 Description	1	8.6 Control Register.....	14
4 Revision History	2	9 Application and Implementation	17
5 Pin Configuration and Functions	3	9.1 Application Information.....	17
6 Specifications	4	9.2 Typical Application.....	17
6.1 Absolute Maximum Ratings.....	4	10 Power Supply Recommendations	20
6.2 ESD Ratings.....	4	10.1 Power-On Reset Requirements.....	20
6.3 Recommended Operating Conditions.....	4	11 Layout	22
6.4 Thermal Information.....	5	11.1 Layout Guidelines.....	22
6.5 Electrical Characteristics.....	5	11.2 Layout Example.....	22
6.6 I ² C Interface Timing Requirements.....	7	12 Device and Documentation Support	23
6.7 Switching Characteristics.....	8	12.1 Receiving Notification of Documentation Updates.....	23
6.8 Interrupt and Reset Timing Requirements.....	8	12.2 Support Resources.....	23
7 Parameter Measurement Information	9	12.3 Trademarks.....	23
8 Detailed Description	11	12.4 Electrostatic Discharge Caution.....	23
8.1 Overview.....	11	12.5 Glossary.....	23
8.2 Functional Block Diagram.....	11	13 Mechanical, Packaging, and Orderable Information	23
8.3 Feature Description.....	12		

4 Revision History

Changes from Revision A (April 2014) to Revision B (march 2021)	Page
• Added the SOIC package to the <i>Device Information</i> table.....	1
• Deleted Package thermal impedance from the <i>Absolute Maximum Ratings</i>	4
• Moved the "Storage temperature range" to the <i>Absolute Maximum Ratings</i>	4
• Changed the PW package values in the <i>Thermal Information</i>	5
• Added D package values to the <i>Thermal Information</i>	5
• Changed the V _{PORR} row in the <i>Electrical Characteristics</i>	5
• Added V _{PORF} row to the <i>Electrical Characteristics</i>	5
• Changed the I _{CC} Low inputs and High inputs values in the <i>Electrical Characteristics</i>	5
• Changed the C _i SCL values in the <i>Electrical Characteristics</i>	5
• Changed the R _{on} (4.5 V to 5.5 V) TYP value From: 9 Ω To: 10 Ω in the <i>Electrical Characteristics</i>	5
• Changed the R _{on} (3 V to 3.6 V) TYP value From: 11 Ω To: 13 Ω in the <i>Electrical Characteristics</i>	5
• Changed Figure 9-2	19
• Changed the <i>Power Supply Recommendations</i>	20

Changes from Revision * (September 2007) to Revision A (April 2014)	Page
• Removed Ordering Information table.....	1

5 Pin Configuration and Functions

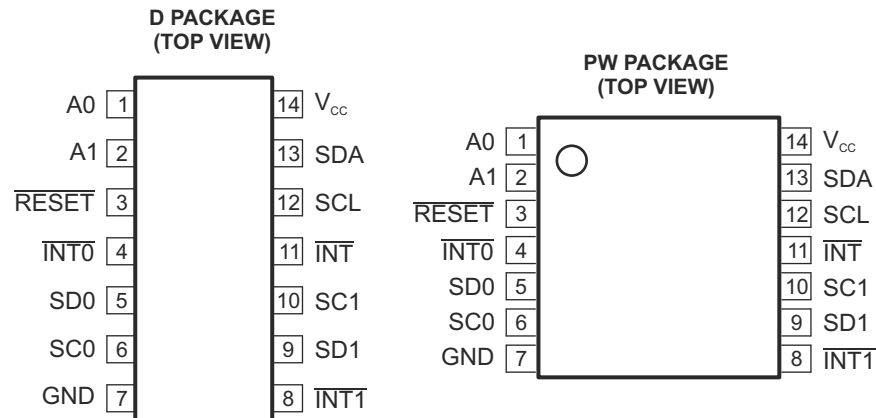

Table 5-1. Pin Functions

PIN		DESCRIPTION
NAME	D, PW	
A0	1	Address input 0. Connect directly to V_{CC} or ground.
A1	2	Address input 1. Connect directly to V_{CC} or ground.
RESET	3	Active-low reset input. Connect to V_{CC} or V_{DPUM} ⁽¹⁾ through a pull-up resistor, if not used.
INT0	4	Active-low interrupt input 0. Connect to V_{DPU0} ⁽¹⁾ through a pull-up resistor.
SD0	5	Serial data 0. Connect to V_{DPU0} ⁽¹⁾ through a pull-up resistor.
SC0	6	Serial clock 0. Connect to aV_{DPU0} ⁽¹⁾ through a pull-up resistor.
GND	7	Ground
INT1	8	Active-low interrupt input 1. Connect to V_{DPU1} ⁽¹⁾ through a pull-up resistor.
SD1	9	Serial data 1. Connect to V_{DPU1} ⁽¹⁾ through a pull-up resistor.
SC1	10	Serial clock 1. Connect to V_{DPU1} ⁽¹⁾ through a pull-up resistor.
INT	11	Active-low interrupt output. Connect to V_{DPUM} ⁽¹⁾ through a pull-up resistor.
SCL	12	Serial clock line. Connect to V_{DPUM} ⁽¹⁾ through a pull-up resistor.
SDA	13	Serial data line. Connect to V_{DPUM} ⁽¹⁾ through a pull-up resistor.
VCC	14	Supply power

(1) V_{DPUX} is the pull-up reference voltage for the associated data line. V_{DPUM} is the master I²C reference voltage while V_{DPU0} and V_{DPU1} are the slave channel reference voltages.

6 Specifications

6.1 Absolute Maximum Ratings

over operating free-air temperature range (unless otherwise noted) ⁽¹⁾

		MIN	MAX	UNIT
V _{CC}	Supply voltage range	-0.5	7	V
V _I	Input voltage range ⁽²⁾	-0.5	7	V
I _I	Input current		±20	mA
I _O	Output current		±25	mA
	Continuous current through V _{CC}		±100	mA
	Continuous current through GND		±100	mA
P _{tot}	Total power dissipation		400	mW
T _A	Operating free-air temperature range	-40	85	°C
T _{stg}	Storage temperature range	-60	150	°C

- (1) Stresses beyond those listed under “absolute maximum ratings” may cause permanent damage to the device. These are stress ratings only, and functional operation of the device at these or any other conditions beyond those indicated under “recommended operating conditions” is not implied. Exposure to absolute-maximum-rated conditions for extended periods may affect device reliability.
- (2) The input negative-voltage and output voltage ratings may be exceeded if the input and output current ratings are observed.

6.2 ESD Ratings

			MIN	MAX	UNIT
V _(ESD)	Electrostatic discharge	Human body model (HBM), per ANSI/ESDA/JEDEC JS-001, all pins ⁽¹⁾	0	2000	V
		Charged device model (CDM), per JEDEC specification JESD22-C101, all pins ⁽²⁾	0	1000	

- (1) JEDEC document JEP155 states that 500-V HBM allows safe manufacturing with a standard ESD control process.
- (2) JEDEC document JEP157 states that 250-V CDM allows safe manufacturing with a standard ESD control process.

6.3 Recommended Operating Conditions

See ⁽¹⁾

			MIN	MAX	UNIT	
V _{CC}	Supply voltage		2.3	5.5	V	
V _{IH}	High-level input voltage	SCL, SDA	0.7 × V _{CC}	6	V	
		A1, A0, $\overline{\text{INT1}}$, $\overline{\text{INT0}}$, $\overline{\text{RESET}}$	V _{CC} = 2.3 V to 3.6 V	0.7 × V _{CC}		V _{CC} + 0.5
			V _{CC} = 3.6 V to 4.5 V	0.7 × V _{CC}		V _{CC} + 0.5
		V _{CC} = 4.5 V to 5.5 V	0.7 × V _{CC}	V _{CC} + 0.5		
V _{IL}	Low-level input voltage	SCL, SDA	-0.5	0.3 × V _{CC}	V	
		A1, A0, $\overline{\text{INT1}}$, $\overline{\text{INT0}}$, $\overline{\text{RESET}}$	-0.5	0.3 × V _{CC}		
T _A	Operating free-air temperature		-40	85	°C	

- (1) All unused inputs of the device must be held at V_{CC} or GND to ensure proper device operation. Refer to the TI application report, *Implications of Slow or Floating CMOS Inputs*, literature number SCBA004.

6.4 Thermal Information

THERMAL METRIC ⁽¹⁾		PCA9543A	PCA9543A	UNIT
		PW (TSSOP)	D (SOIC)	
		14 PINS	14 PINS	
R _{θJA}	Junction-to-ambient thermal resistance	130.1	102.8	°C/W
R _{θJCTop}	Junction-to-case (top) thermal resistance	59.2	63.9	
R _{θJB}	Junction-to-board thermal resistance	73.1	57.1	
ψ _{JT}	Junction-to-top characterization parameter	11.7	26.7	
ψ _{JB}	Junction-to-board characterization parameter	72.5	56.8	

(1) For more information about traditional and new thermal metrics, see the *IC Package Thermal Metrics* application report, [SPRA953](#).

6.5 Electrical Characteristics

over recommended operating free-air temperature range (unless otherwise noted) ⁽¹⁾

PARAMETER		TEST CONDITIONS	V _{CC}	MIN	TYP	MAX	UNIT
V _{PORR}	Power-on reset voltage, V _{CC} rising	No load: V _I = V _{CC} or GND ⁽²⁾			1.2	1.5	V
V _{PORF}	Power-on reset voltage, V _{CC} falling	No load: V _I = V _{CC} or GND ⁽²⁾		0.8	1		V
V _{pass}	Switch output voltage	V _{SWin} = V _{CC} , I _{SWout} = -100 μA	5 V		3.6		V
			4.5 V to 5.5 V	2.6		4.5	
			3.3 V		1.9		
			3 V to 3.6 V	1.6		2.8	
			2.5 V		1.5		
			2.3 V to 2.7 V	1.1		2	
I _{OH}	INT [¯]	V _O = V _{CC}	2.3 V to 5.5 V			100	μA
I _{OL}	SDA	V _{OL} = 0.4 V	2.3 V to 5.5 V	3	7		mA
		V _{OL} = 0.6 V		6	10		
	INT [¯]	V _{OL} = 0.4 V		3			
I _I	SCL, SDA	V _I = V _{CC} or GND	2.3 V to 5.5 V	-1		1	μA
	SC1–SC0, SD1–SD0	V _I = V _{CC} or GND	2.3 V to 3.6 V	-1		1	
			4.5 V to 5.5 V	-1		100	
	A1, A0	V _I = V _{CC} or GND	2.3 V to 3.6 V	-1		1	
			4.5 V to 5.5 V	-1		50	
	INT1– INT0	V _I = V _{CC} or GND	2.3 V to 3.6 V	-1		1	
			4.5 V to 5.5 V	-1		50	
	RESET	V _I = V _{CC} or GND	2.3 V to 3.6 V	-1		1	
4.5 V to 5.5 V			-1		50		

6.5 Electrical Characteristics (continued)

over recommended operating free-air temperature range (unless otherwise noted) ⁽¹⁾

PARAMETER		TEST CONDITIONS	V _{CC}	MIN	TYP	MAX	UNIT
I _{CC}	Operating mode	f _{SCL} = 100 kHz V _I = V _{CC} or GND, I _O = 0	5.5 V		17	50	μA
			3.6 V		6	20	
			2.7 V		3	16	
	Standby mode	Low inputs V _I = GND, I _O = 0	5.5 V		1.6	2	
			3.6 V		1	1.3	
			2.7 V		0.7	1.1	
		High inputs V _I = V _{CC} , I _O = 0	5.5 V		1.6	2	
			3.6 V		1	1.3	
			2.7 V		0.7	1.1	
ΔI _{CC}	Supply-current change	INT1–INT0 One INT1–INT0 input at 0.6 V, Other inputs at V _{CC} or GND	2.3 V to 5.5 V		8	20	μA
				One INT1–INT0 input at V _{CC} – 0.6 V, Other inputs at V _{CC} or GND		8	
		SCL, SDA SCL or SDA input at 0.6 V, Other inputs at V _{CC} or GND			8	20	
				SCL or SDA input at V _{CC} – 0.6 V, Other inputs at V _{CC} or GND		8	
C _i	A1, A0	V _I = V _{CC} or GND	2.3 V to 3.6 V		4	5	pF
			4.5 V to 5.5 V		4	5	
	INT1–INT0	V _I = V _{CC} or GND	2.3 V to 3.6 V		4	6	
			4.5 V to 5.5 V		4	6	
	RESET	V _I = V _{CC} or GND	2.3 V to 3.6 V		4	5	
			4.5 V to 5.5 V		4	5	
	SCL	V _I = V _{CC} or GND	2.3 V to 5.5 V		15	19	
					15	19	
C _{i o(OFF)} ⁽³⁾	SDA	V _I = V _{CC} or GND, Switch OFF	2.3 V to 5.5 V		6	8	pF
	SC1–SC0, SD1–SD0						
R _{on}	Switch on-state resistance	V _O = 0.4 V, I _O = 15 mA	4.5 V to 5.5 V	4	10	20	Ω
			3 V to 3.6 V	5	13	25	
		V _O = 0.4 V, I _O = 10 mA	2.3 V to 2.7 V	7	16	50	

(1) For operation between published voltage ranges, refer to the worst-case parameter in both ranges.

(2) To reset the part, either RESET must be low or V_{CC} must be lowered to 0.2 V.

(3) C_{i o(ON)} depends on the device capacitance and load that is downstream from the device.

6.6 I²C Interface Timing Requirements

over recommended operating free-air temperature range (unless otherwise noted) (see [Figure 7-1](#))

		STANDARD MODE I ² C BUS		FAST MODE I ² C BUS		UNIT
		MIN	MAX	MIN	MAX	
f_{scl}	I ² C clock frequency	0	100	0	400	kHz
t_{sch}	I ² C clock high time	4		0.6		μs
t_{scl}	I ² C clock low time	4.7		1.3		μs
t_{sp}	I ² C spike time		50		50	ns
t_{sds}	I ² C serial-data setup time	250		100		ns
t_{sdh}	I ² C serial-data hold time	0 ⁽¹⁾		0 ⁽¹⁾		μs
t_{icr}	I ² C input rise time		1000	$20 + 0.1C_b$ ⁽²⁾	300	ns
t_{icf}	I ² C input fall time		300	$20 + 0.1C_b$ ⁽²⁾	300	ns
t_{ocf}	I ² C output fall time	10-pF to 400-pF bus	300	$20 + 0.1C_b$ ⁽²⁾	300	ns
t_{buf}	I ² C bus free time between stop and start	4.7		1.3		μs
t_{sts}	I ² C start or repeated start condition setup	4.7		0.6		μs
t_{sth}	I ² C start or repeated start condition hold	4		0.6		μs
t_{sps}	I ² C stop condition setup	4		0.6		μs
$t_{vdL(Data)}$	Valid-data time (high to low) ⁽³⁾	SCL low to SDA output low valid	1		1	μs
$t_{vdH(Data)}$	Valid-data time (low to high) ⁽³⁾	SCL low to SDA output high valid	0.6		0.6	μs
$t_{vd(ack)}$	Valid-data time of ACK condition	ACK signal from SCL low to SDA output low	1		1	μs
C_b	I ² C bus capacitive load		400		400	pF

- (1) A device internally must provide a hold time of at least 300 ns for the SDA signal (referred to as the V_{IH} min of the SCL signal), in order to bridge the undefined region of the falling edge of SCL.
- (2) C_b = total bus capacitance of one bus line in pF
- (3) Data taken using a 1-kΩ pull-up resistor and 50-pF load (see [Figure 7-1](#))

6.7 Switching Characteristics

over recommended operating free-air temperature range, $C_L \leq 100$ pF (unless otherwise noted) (see [Figure 7-3](#))

PARAMETER		FROM (INPUT)	TO (OUTPUT)	MIN	MAX	UNIT
$t_{pd}^{(1)}$	Propagation delay time	SDA or SCL	SDn or SCn		0.3	ns
				$R_{ON} = 20 \Omega, C_L = 15$ pF	1	
t_{iv}	Interrupt valid time ⁽²⁾	\overline{INTn}	\overline{INT}		4	μ s
t_{ir}	Interrupt reset delay time ⁽²⁾	\overline{INTn}	\overline{INT}		2	μ s

- (1) The propagation delay is the calculated RC time constant of the typical ON-state resistance of the switch and the specified load capacitance, when driven by an ideal voltage source (zero output impedance).
- (2) Data taken using a 4.7-k Ω pull-up resistor and 100-pF load (see [Figure 7-3](#))

6.8 Interrupt and Reset Timing Requirements

over recommended operating free-air temperature range (unless otherwise noted) (see [Figure 7-3](#))

PARAMETER		MIN	MAX	UNIT
t_{PWRL}	Required low-level pulse duration of \overline{INTn} inputs ⁽²⁾	1		μ s
t_{PWRH}	Required high-level pulse duration of \overline{INTn} inputs ⁽²⁾	0.5		μ s
t_{WL}	Pulse duration, \overline{RESET} low	4		ns
$t_{rst}^{(1)}$	\overline{RESET} time (SDA clear)		500	ns
t_{REC}	Recovery time from \overline{RESET} to start	0		ns

- (1) t_{rst} is the propagation delay measured from the time the \overline{RESET} pin is first asserted low to the time the SDA pin is asserted high, signaling a stop condition. It must be a minimum of t_{WL} .
- (2) The device has interrupt input rejection circuitry for pulses less than the listed minimum.

7 Parameter Measurement Information

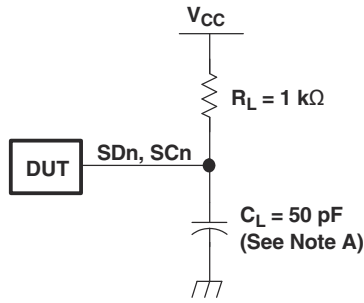

I²C PORT LOAD CONFIGURATION

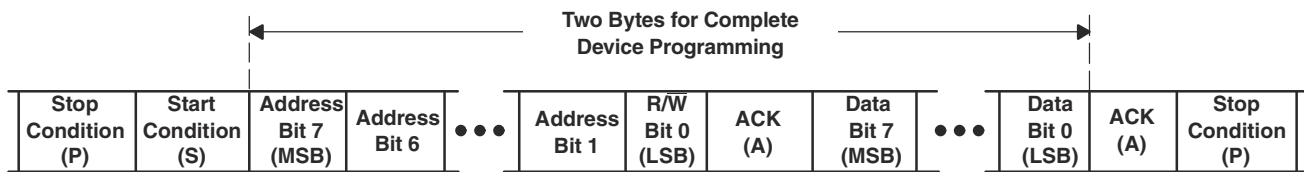

BYTE	DESCRIPTION
1	I ² C address + R/W
2	Control register data

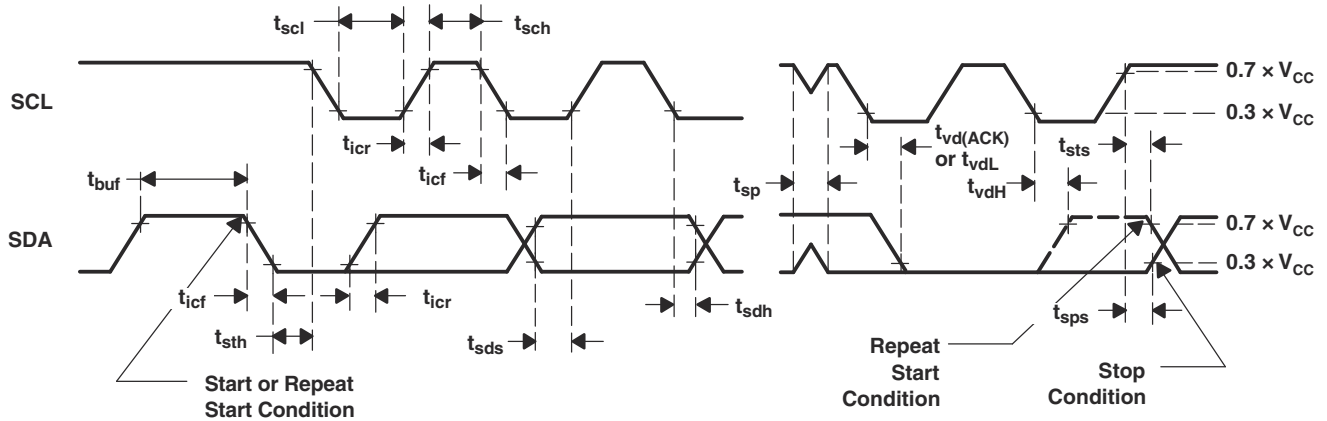

VOLTAGE WAVEFORMS

- A. C_L includes probe and jig capacitance.
- B. All input pulses are supplied by generators having the following characteristics: $PRR \leq 10$ MHz, $Z_O = 50 \Omega$, $t_r/t_f = 30$ ns.
- C. The outputs are measured one at a time, with one transition per measurement.

Figure 7-1. I²C Interface Load Circuit, Byte Descriptions, and Voltage Waveforms

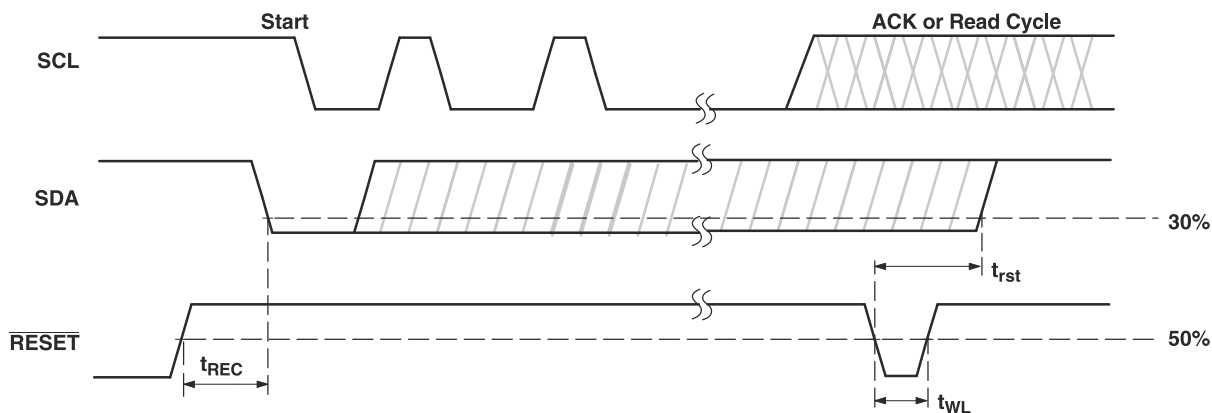
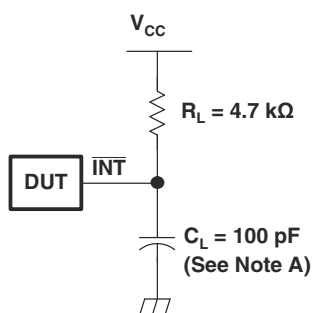
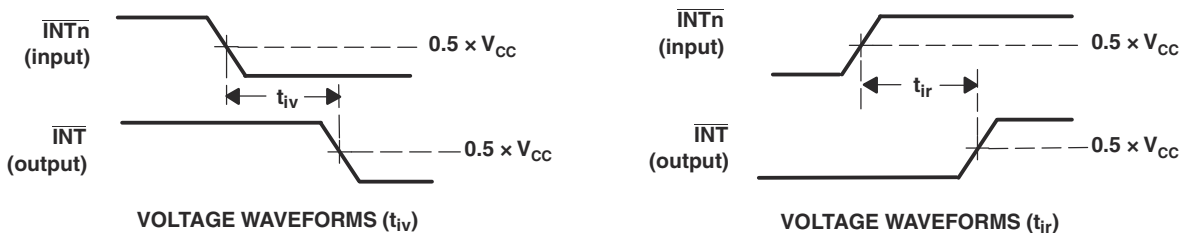

Figure 7-2. Reset Timing



INTERRUPT LOAD CONFIGURATION



- A. C_L includes probe and jig capacitance.
- B. All input pulses are supplied by generators having the following characteristics: $PRR \leq 10 \text{ MHz}$, $Z_O = 50 \Omega$, $t_r/t_f = 30 \text{ ns}$.

Figure 7-3. Interrupt Load Circuit and Voltage Waveforms

8 Detailed Description

8.1 Overview

The PCA9543A is a 2-channel, bidirectional translating I²C switch. The master SCL/SDA signal pair is directed to two channels of slave devices, SC0/SD0-SC1/SD1. Either individual downstream channel can be selected as well as both channels. The PCA9543A also supports interrupt signals in order for the master to detect an interrupt on the $\overline{\text{INT}}$ output pin that can result from any of the slave devices connected to the $\overline{\text{INT1}}$ - $\overline{\text{INT0}}$ input pins.

The device offers an active-low $\overline{\text{RESET}}$ input which resets the state machine and allows the PCA9543A to recover should one of the downstream I²C buses get stuck in a low state. The state machine of the device can also be reset by cycling the power supply, V_{CC}, also known as a power-on reset (POR). Either using the $\overline{\text{RESET}}$ function or causing a POR will cause both channels to be deselected.

The connections of the I²C data path are controlled by the same I²C master device that is switched to communicate with multiple I²C slaves. After the successful acknowledgment of the slave address (hardware selectable by A0 and A1 pins), a single 8-bit control register is written to or read from to determine the selected channels and state of the interrupts.

The PCA9543A may also be used for voltage translation, allowing the use of different bus voltages on each SC_n/SD_n pair such that 1.8-V, 2.5-V, or 3.3-V parts can communicate with 5-V parts. This is achieved by using external pull-up resistors to pull the bus up to the desired voltage for the master and each slave channel.

8.2 Functional Block Diagram

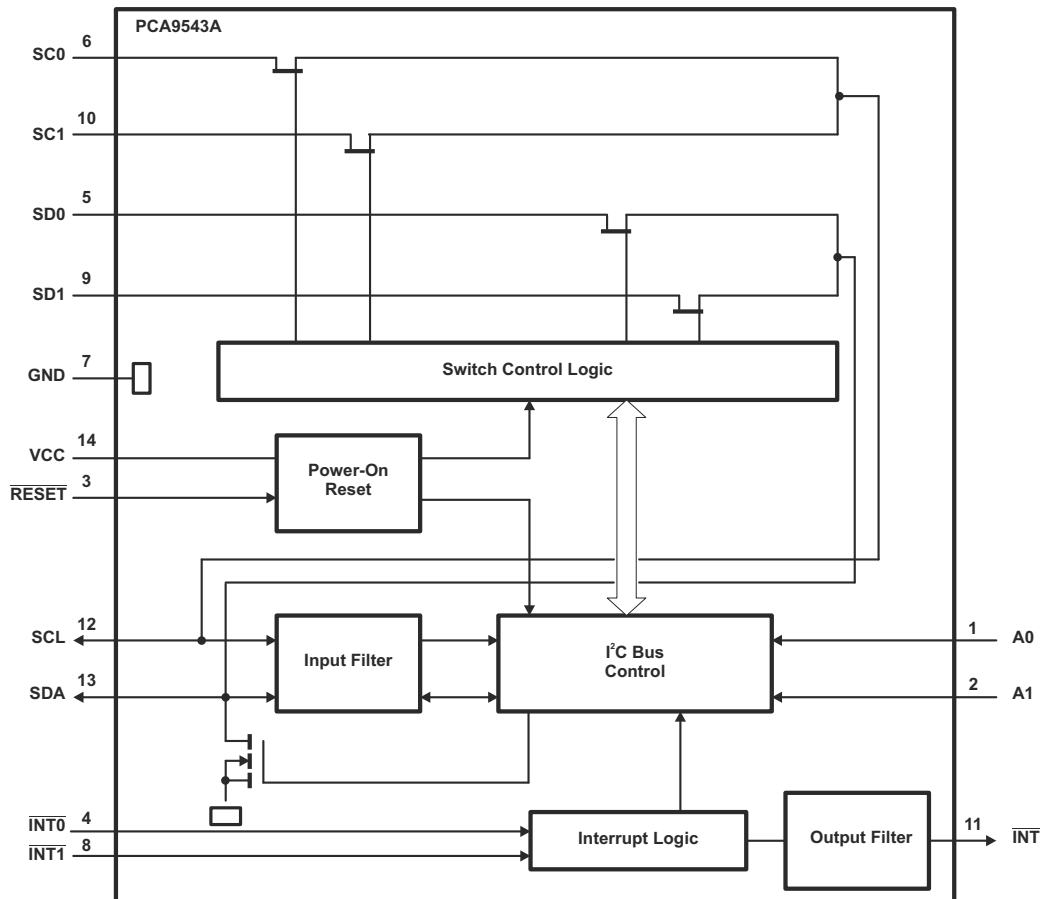

8.3 Feature Description

The PCA9543A is a dual channel bidirectional translating switch for I²C buses that supports Standard-Mode (100 kHz) and Fast-Mode (400 kHz) operation. The PCA9543A features I²C control using a single 8-bit control register in which bits 1 and 0 control the enabling and disabling of the two switch channels of I²C data flow. The PCA9543A also supports interrupt signals for each slave channel and this data is held in bits 5 and 4 of the control register. Depending on the application, voltage translation of the I²C bus can also be achieved using the PCA9543A to allow 1.8-V, 2.5-V, or 3.3-V parts to communicate with 5-V parts. Additionally, in the event that communication on the I²C bus enters a fault state, the PCA9543A can be reset to resume normal operation using the $\overline{\text{RESET}}$ pin feature or by a power-on reset which results from cycling power to the device.

8.4 Device Functional Modes

8.4.1 $\overline{\text{RESET}}$ Input

The $\overline{\text{RESET}}$ input can be used to recover the PCA9543A from a bus-fault condition. The registers and the I²C state machine within this device initialize to their default states if this signal is asserted low for a minimum of t_{WL} . Both channels also are deselected in this case. $\overline{\text{RESET}}$ must be connected to V_{CC} through a pull-up resistor.

8.4.2 Power-On Reset

When power (from 0 V) is applied to V_{CC} , an internal power-on reset holds the PCA9543A in a reset condition until V_{CC} has reached V_{POR} . At that point, the reset condition is released and the PCA9543A registers and I²C/SMBus state machine initialize to their default states. After that, V_{CC} must be lowered to below 0.2 V and then back up to the operating voltage for a power-reset cycle.

8.5 Programming

8.5.1 I²C Interface

The I²C bus is for two-way, two-line communication between different ICs or modules. The two lines are a serial data line (SDA) and a serial clock line (SCL). Both lines must be connected to a positive supply via a pull-up resistor when connected to the output stages of a device. Data transfer may be initiated only when the bus is not busy.

One data bit is transferred during each clock pulse. The data on the SDA line must remain stable during the high period of the clock pulse as changes in the data line at this time is interpreted as control signals (see [Figure 8-1](#)).

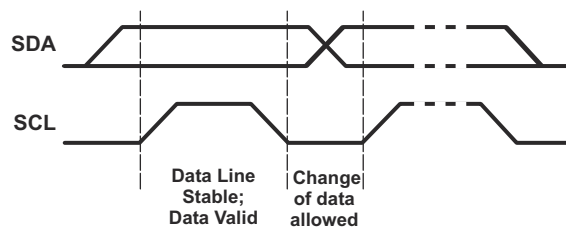

Figure 8-1. Bit Transfer

Both data and clock lines remain high when the bus is not busy. A high-to-low transition of the data line while the clock is high is defined as the start condition (S). A low-to-high transition of the data line while the clock is high is defined as the stop condition (P) (see [Figure 8-2](#)).

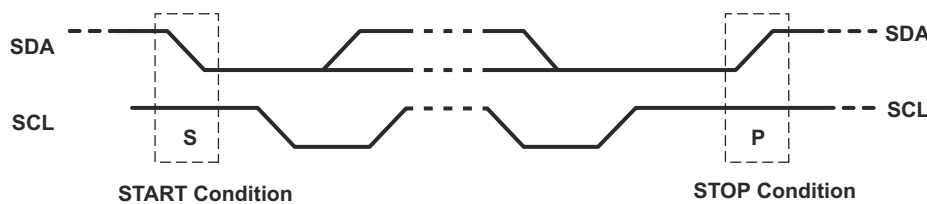

Figure 8-2. Definition of Start and Stop Conditions

A device generating a message is a transmitter; a device receiving a message is the receiver. The device that controls the message is the master and the devices that are controlled by the master are the slaves (see [Figure 8-3](#)).

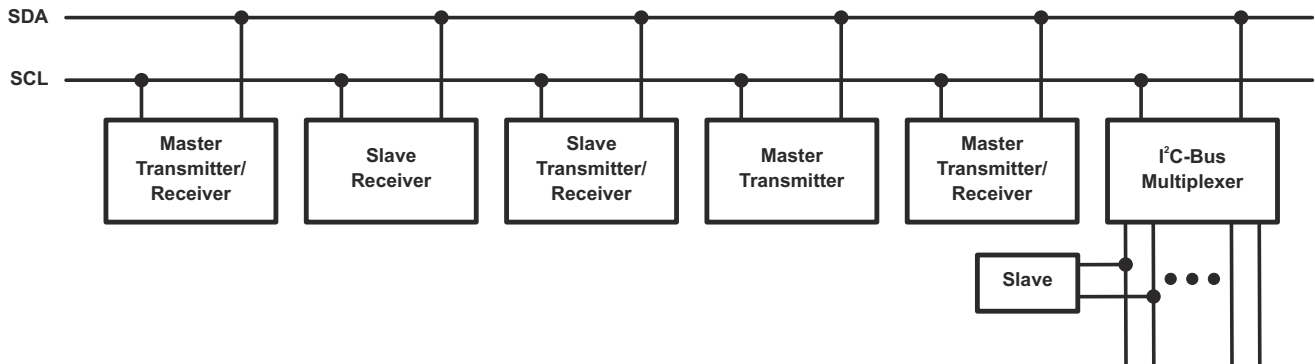

Figure 8-3. System Configuration

The number of data bytes transferred between the start and the stop conditions from transmitter to receiver is not limited. Each byte of eight bits is followed by one acknowledge (ACK) bit. The transmitter must release the SDA line before the receiver can send an ACK bit.

When a slave receiver is addressed, it must generate an ACK after the reception of each byte. Also, a master must generate an ACK after the reception of each byte that has been clocked out of the slave transmitter. The device that acknowledges must pull down the SDA line during the ACK clock pulse, so that the SDA line is stable low during the high pulse of the ACK-related clock period (see [Figure 8-4](#)). Setup and hold times must be taken into account.

A master receiver must signal an end of data to the transmitter by not generating an acknowledge (NACK) after the last byte has been clocked out of the slave. This is done by the master receiver by holding the SDA line high. In this event, the transmitter must release the data line to enable the master to generate a stop condition.

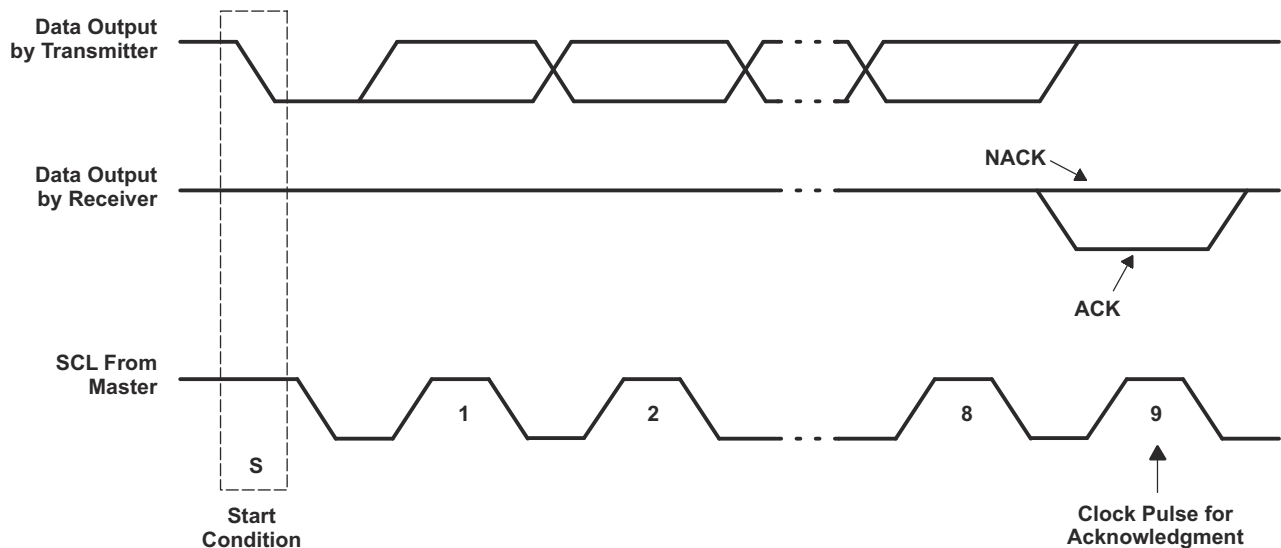

Figure 8-4. Acknowledgment on I²C Bus

Data is transmitted to the PCA9543A control register using the write mode shown in [Figure 8-5](#).

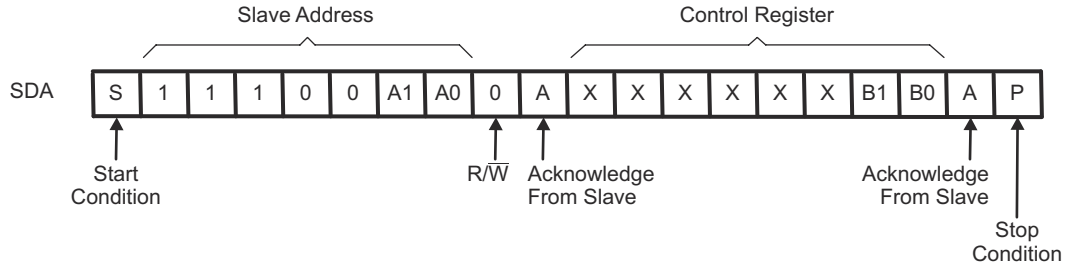

Figure 8-5. Write Control Register

Data is read from the PCA9543A control register using the read mode shown in [Figure 8-6](#).

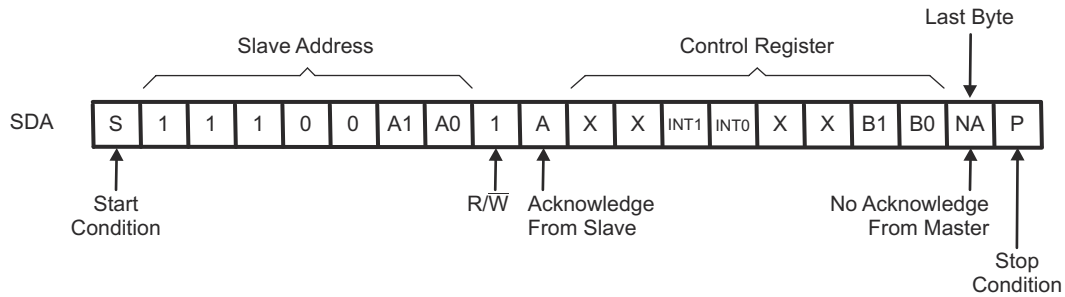

Figure 8-6. Read Control Register

8.6 Control Register

8.6.1 Device Address

Following a start condition, the bus master must output the address of the slave it is accessing. The address of the PCA9543A is shown in [Figure 8-7](#). To conserve power, no internal pull-up resistors are incorporated on the hardware-selectable address pins and they must be pulled high or low.

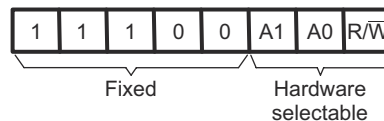

Figure 8-7. Slave Address PCA9543A

The last bit of the slave address defines the operation to be performed. When set to a logic 1, a read is selected, while a logic 0 selects a write operation.

8.6.2 Control Register Description

Following the successful acknowledgment of the slave address, the bus master sends a byte to the PCA9543A, which is stored in the control register (see [Figure 8-8](#)). If multiple bytes are received by the PCA9543A, it saves the last byte received. This register can be written and read via the I²C bus.

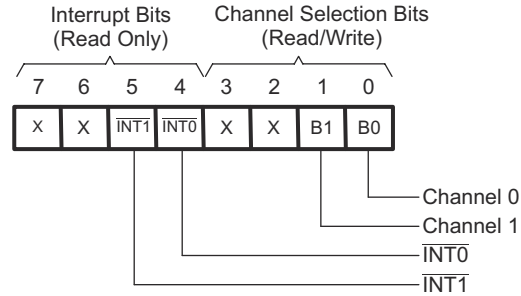

Figure 8-8. Control Register

8.6.3 Control Register Definition

One or both SCn/SDn downstream pairs, or channels, are selected by the contents of the control register (see [Table 8-1](#)). After the PCA9543A has been addressed, the control register is written. The two LSBs of the control byte are used to determine which channel or channels are to be selected. When a channel is selected, the channel becomes active after a stop condition has been placed on the I²C bus. This ensures that all SCn/SDn lines are in a high state when the channel is made active, so that no false conditions are generated at the time of connection. A stop condition must occur always right after the acknowledge cycle.

Table 8-1. Control Register Write (Channel Selection), Control Register Read (Channel Status) ⁽¹⁾

D7	D6	INT1	INT0	D3	D2	B1	B0	COMMAND
X	X	X	X	X	X	X	0	Channel 0 disabled
							1	Channel 0 enabled
X	X	X	X	X	X	0	X	Channel 1 disabled
								1
0	0	0	0	0	0	0	0	No channel selected; power-up/reset default state

(1) Channel 0 and channel 1 can be enabled at the same time. Care should be taken not to exceed the maximum bus capacitance.

8.6.4 Interrupt Handling

The PCA9543A provides two interrupt inputs (one for each channel) and one open-drain interrupt output (see [Table 8-2](#)). When an interrupt is generated by any device, it is detected by the PCA9543A and the interrupt output is driven low. The channel does not need to be active for detection of the interrupt. A bit also is set in the control register.

Bit 4 and Bit 5 of the control register correspond to the $\overline{\text{INT0}}$ and $\overline{\text{INT1}}$ inputs of the PCA9543A, respectively. Therefore, if an interrupt is generated by any device connected to channel 1, the state of the interrupt inputs is loaded into the control register when a read is accomplished. Likewise, an interrupt on any device connected to channel 0 would cause bit 4 of the control register to be set on the read. The master then can address the PCA9543A and read the contents of the control register to determine which channel contains the device generating the interrupt. The master then can reconfigure the PCA9543A to select this channel, and locate the device generating the interrupt and clear it.

It should be noted that more than one device can provide an interrupt on a channel, so it is up to the master to ensure that all devices on a channel are interrogated for an interrupt.

The interrupt inputs may be used as general-purpose inputs if the interrupt function is not required.

If unused, interrupt input(s) must be connected to V_{CC} through a pull-up resistor.

Table 8-2. Control Register Read (Interrupt) ⁽¹⁾

D7	D6	INT1	INT0	D3	D2	B1	B0	COMMAND
X	X	X	0	X	X	X	X	No interrupt on channel 0
			1					Interrupt on channel 0
X	X	0	X	X	X	X	X	No interrupt on channel 1
		1						Interrupt on channel 1
0	0	0	0	0	0	0	0	No channel selected; power-up/reset default state

(1) Two interrupts can be active at the same time.

9 Application and Implementation

Note

Information in the following applications sections is not part of the TI component specification, and TI does not warrant its accuracy or completeness. TI's customers are responsible for determining suitability of components for their purposes. Customers should validate and test their design implementation to confirm system functionality.

9.1 Application Information

Applications of the PCA9543A will contain an I²C (or SMBus) master device and up to two I²C slave devices. The downstream channels are ideally used to resolve I²C slave address conflicts. For example, if two identical digital temperature sensors are needed in the application, one sensor can be connected at each channel: 0 and 1. When the temperature at a specific location needs to be read, the appropriate channel can be enabled and the other channel switched off, the data can be retrieved, and the I²C master can move on and read the next channel.

In an application where the I²C bus will contain many additional slave devices that do not result in I²C slave address conflicts, these slave devices can be connected to any desired channel to distribute the total bus capacitance across both channels. If both switches will be enabled simultaneously, additional design requirements must be considered (See [Design Requirements](#) and [Detailed Design Procedure](#)).

9.2 Typical Application

A typical application of the PCA9543A will contain anywhere from 1 to 3 separate data pull-up voltages, V_{DPUX} , one for the master device (V_{DPUM}) and one for each of the selectable slave channels (V_{DPU0} and V_{DPU1}). In the event where the master device and both slave devices operate at the same voltage, then the pass voltage, $V_{pass} = V_{DPUX}$. Once the maximum V_{pass} is known, V_{CC} can be selected using [Figure 9-2](#). In an application where voltage translation is necessary, additional design requirements must be considered (See [Design Requirements](#)).

[Figure 9-1](#) shows an application in which the PCA9543A can be used.

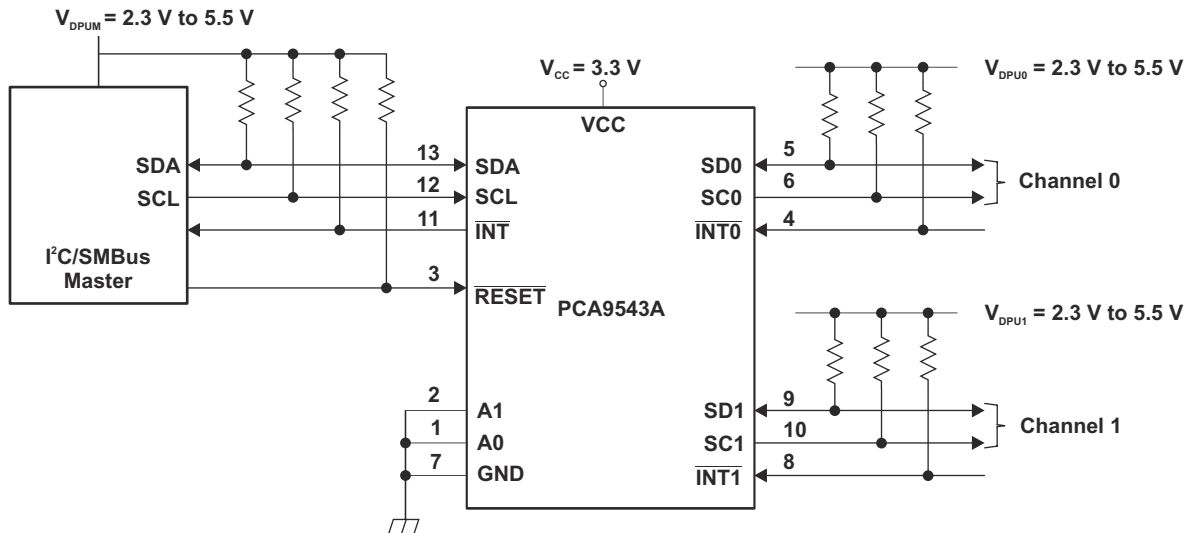

Figure 9-1. Typical Application

9.2.1 Design Requirements

The pull-up resistors on the $\overline{\text{INT1}}$ - $\overline{\text{INT0}}$ pins in the application schematic are not required in all applications. If the device generating the interrupt has an open-drain output structure or can be tri-stated, a pull-up resistor is required. If the device generating the interrupt has a push-pull output structure and cannot be tri-stated, a pull-up resistor is not required. The interrupt inputs should not be left floating in the application.

The A0 and A1 pins are hardware selectable to control the slave address of the PCA9543A. These pins may be tied directly to GND or V_{CC} in the application.

If both slave channels will be activated simultaneously in the application, then the total I_{OL} from SCL/SDA to GND on the master side will be the sum of the currents through all pull-up resistors, R_p .

The pass-gate transistors of the PCA9543A are constructed such that the V_{CC} voltage can be used to limit the maximum voltage that is passed from one I²C bus to another.

Figure 9-2 shows the voltage characteristics of the pass-gate transistors (note that the graph was generated using data specified in the [Electrical Characteristics](#) section of this data sheet). In order for the PCA9543A to act as a voltage translator, the V_{pass} voltage must be equal to or lower than the lowest bus voltage. For example, if the main bus is running at 5 V and the downstream buses are 3.3 V and 2.7 V, V_{pass} must be equal to or below 2.7 V to effectively clamp the downstream bus voltages. As shown in Figure 9-2, $V_{pass(max)}$ is 2.7 V when the PCA9543A supply voltage is 4 V or lower, so the PCA9543A supply voltage could be set to 3.3 V. Pull-up resistors then can be used to bring the bus voltages to their appropriate levels (see Figure 9-1).

9.2.2 Detailed Design Procedure

Once all the slaves are assigned to the appropriate slave channels and bus voltages are identified, the pull-up resistors, R_p , for each of the buses need to be selected appropriately. The minimum pull-up resistance is a function of V_{DPUX} , $V_{OL(max)}$, and I_{OL} :

$$R_{p(min)} = \frac{V_{DPUX} - V_{OL(max)}}{I_{OL}} \quad (1)$$

The maximum pull-up resistance is a function of the maximum rise time, t_r (300 ns for fast-mode operation, $f_{SCL} = 400$ kHz) and bus capacitance, C_b :

$$R_{p(max)} = \frac{t_r}{0.8473 \times C_b} \quad (2)$$

The maximum bus capacitance for an I²C bus must not exceed 400 pF for fast-mode operation. The bus capacitance can be approximated by adding the capacitance of the PCA9543A, $C_{iO(OFF)}$, the capacitance of wires/connections/traces, and the capacitance of each individual slave on a given channel. If both channels will be activated simultaneously, each of the slaves on both channels will contribute to total bus capacitance.

9.2.3 Application Curves

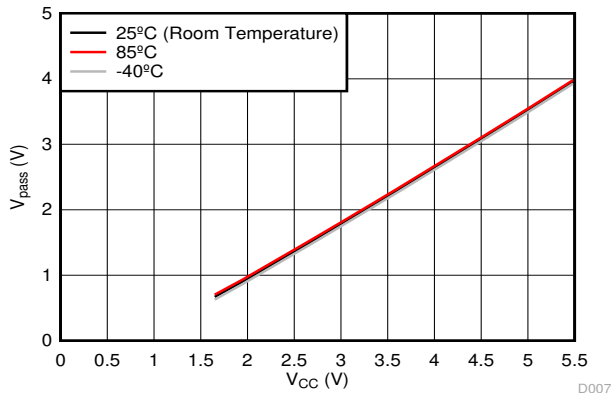
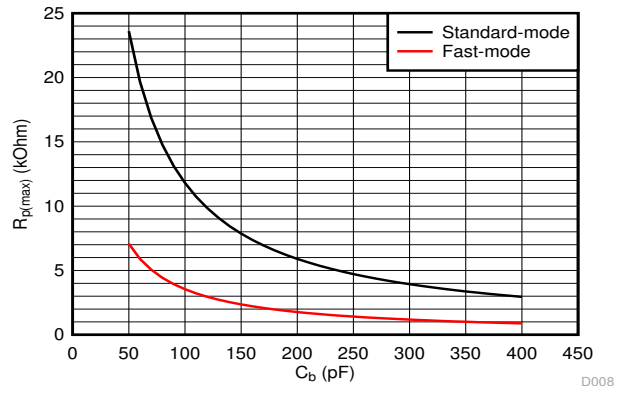
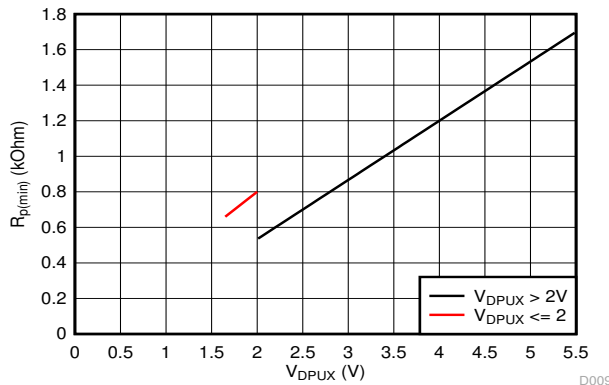

Figure 9-2. Pass-Gate Voltage (V_{pass}) vs Supply Voltage (V_{CC}) at Three Temperature Points



Standard-mode ($f_{SCL} = 100$ kHz, $t_r = 1$ μ s) Fast-mode ($f_{SCL} = 400$ kHz, $t_r = 300$ ns)

Figure 9-3. Maximum Pull-Up Resistance ($R_{p(max)}$) vs Bus Capacitance (C_b)



A.

$V_{OL} = 0.2 \cdot V_{DPUX}$, $I_{OL} = 2$ mA when $V_{DPUX} \leq 2$ V
 $V_{OL} = 0.4$ V, $I_{OL} = 3$ mA when $V_{DPUX} > 2$ V

Figure 9-4. Minimum Pull-Up Resistance ($R_{p(min)}$) vs Pull-Up Reference Voltage (V_{DPUX})

10 Power Supply Recommendations

10.1 Power-On Reset Requirements

In the event of a glitch or data corruption, PCA9543A can be reset to its default conditions by using the power-on reset feature. Power-on reset requires that the device go through a power application cycle to be completely reset. This reset also happens when the device is powered on for the first time in an application.

The two types of power-on reset are shown in [Figure 10-1](#) and [Figure 10-2](#).

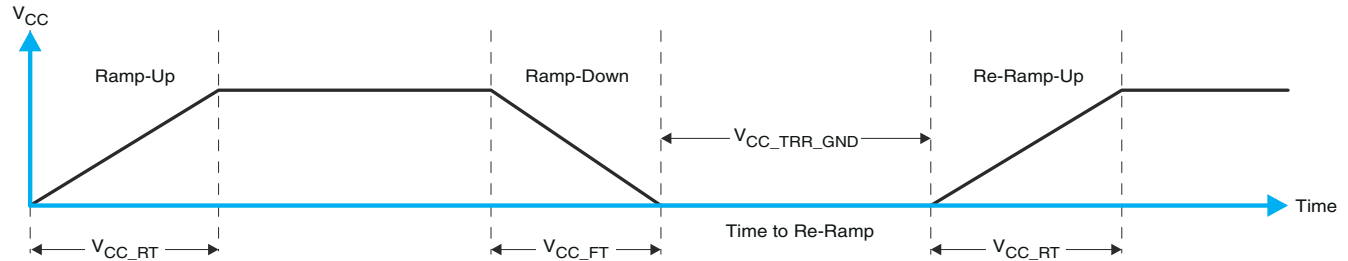

Figure 10-1. V_{CC} Is Lowered Below 0.2 V Or 0 V And Then Ramped Up To V_{CC}

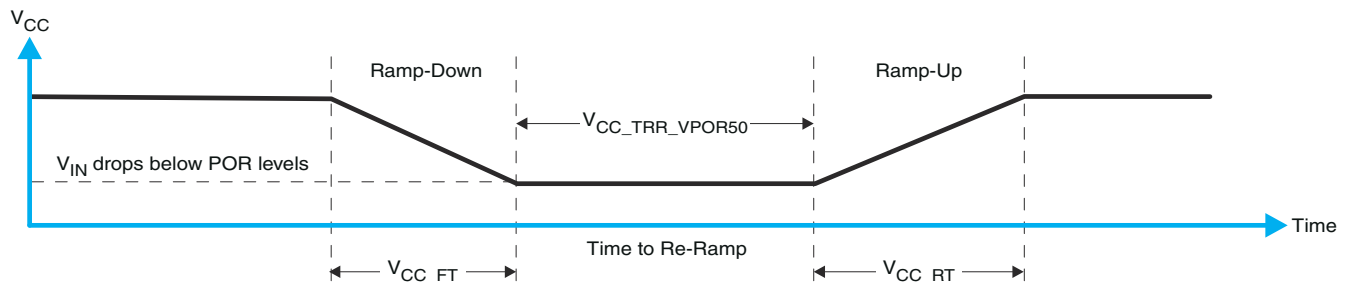

Figure 10-2. V_{CC} Is Lowered Below The Por Threshold, Then Ramped Back Up To V_{CC}

[Table 10-1](#) specifies the performance of the power-on reset feature for PCA9543A for both types of power-on reset.

Table 10-1. Recommended Supply Sequencing And Ramp Rates ⁽¹⁾

PARAMETER			MIN	TYP	MAX	UNIT
V_{CC_FT}	Fall rate	See Figure 10-1	1		100	ms
V_{CC_RT}	Rise rate	See Figure 10-1	0.01		100	ms
$V_{CC_TRR_GND}$	Time to re-ramp (when V_{CC} drops to GND)	See Figure 10-1	0.001			ms
$V_{CC_TRR_POR50}$	Time to re-ramp (when V_{CC} drops to $V_{POR_MIN} - 50$ mV)	See Figure 10-2	0.001			ms
V_{CC_GH}	Level that V_{CCP} can glitch down to, but not cause a functional disruption when $V_{CCX_GW} = 1$ μ s	See Figure 10-3			1.2	V
V_{CC_GW}	Glitch width that will not cause a functional disruption when $V_{CCX_GH} = 0.5 \times V_{CCX}$	See Figure 10-3				μ s
V_{PORF}	Voltage trip point of POR on falling V_{CC}		0.767		1.144	V
V_{PORR}	Voltage trip point of POR on rising V_{CC}		1.033		1.428	V

(1) $T_A = -40^\circ\text{C}$ to 85°C (unless otherwise noted)

Glitches in the power supply can also affect the power-on reset performance of this device. The glitch width (V_{CC_GW}) and height (V_{CC_GH}) are dependent on each other. The bypass capacitance, source impedance, and the device impedance are factors that affect power-on reset performance. [Figure 10-3](#) and [Table 10-1](#) provide more information on how to measure these specifications.

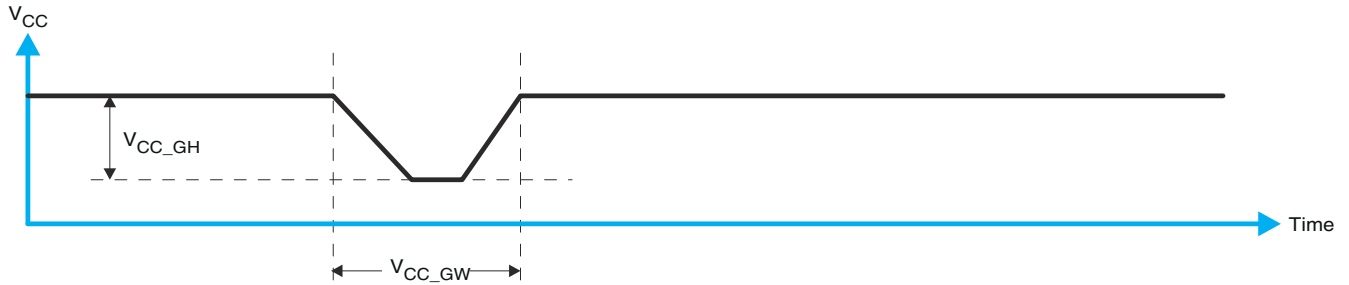

Figure 10-3. Glitch Width And Glitch Height

V_{POR} is critical to the power-on reset. V_{POR} is the voltage level at which the reset condition is released and all the registers and the I²C/SMBus state machine are initialized to their default states. The value of V_{POR} differs based on the V_{CC} being lowered to or from 0. [Figure 10-4](#) and [Table 10-1](#) provide more details on this specification.

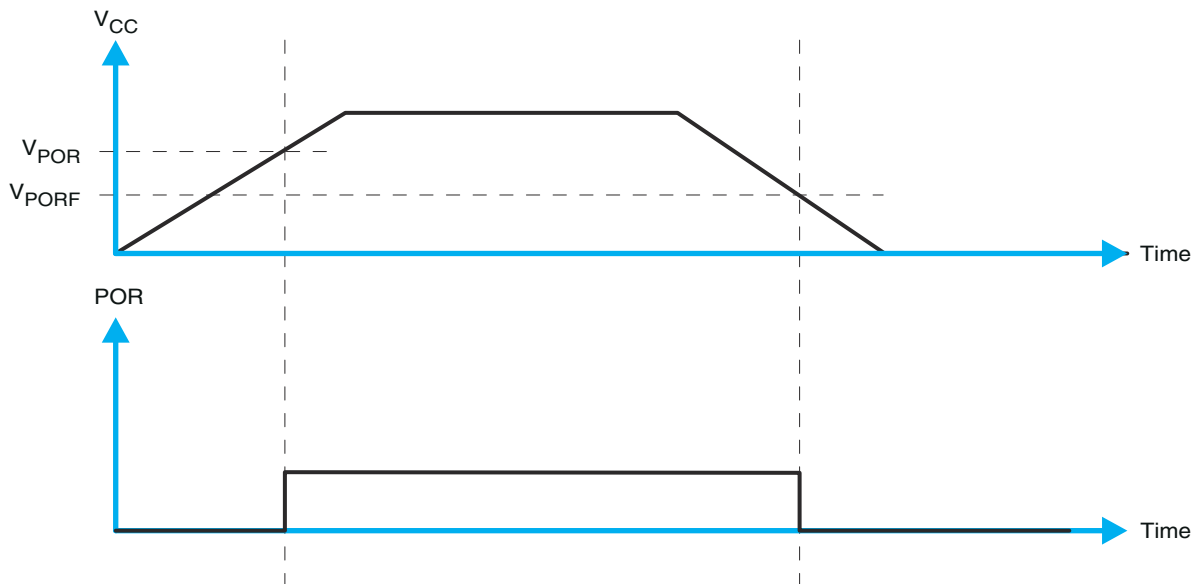

Figure 10-4. V_{POR}

11 Layout

11.1 Layout Guidelines

For PCB layout of the PCA9543A, common PCB layout practices should be followed but additional concerns related to high-speed data transfer such as matched impedances and differential pairs are not a concern for I²C signal speeds. It is common to have a dedicated ground plane on an inner layer of the board and pins that are connected to ground should have a low-impedance path to the ground plane in the form of wide polygon pours and multiple vias. By-pass and de-coupling capacitors are commonly used to control the voltage on the VCC pin, using a larger capacitor to provide additional power in the event of a short power supply glitch and a smaller capacitor to filter out high-frequency ripple.

In an application where voltage translation is not required, all V_{DPUX} voltages and V_{CC} could be at the same potential and a single copper plane can connect all of the pull-up resistors to the appropriate reference voltage. In an application where voltage translation is required, V_{DPUM}, V_{DPU0}, and V_{DPU1}, may all be on the same layer of the board with split planes to isolate different voltage potentials.

To reduce the total I²C bus capacitance added by PCB parasitics, data lines (SC_n, SD_n and $\overline{\text{INT}}_n$) should be as short as possible and the widths of the traces should also be minimized (e.g. 5-10 mils depending on copper weight).

11.2 Layout Example

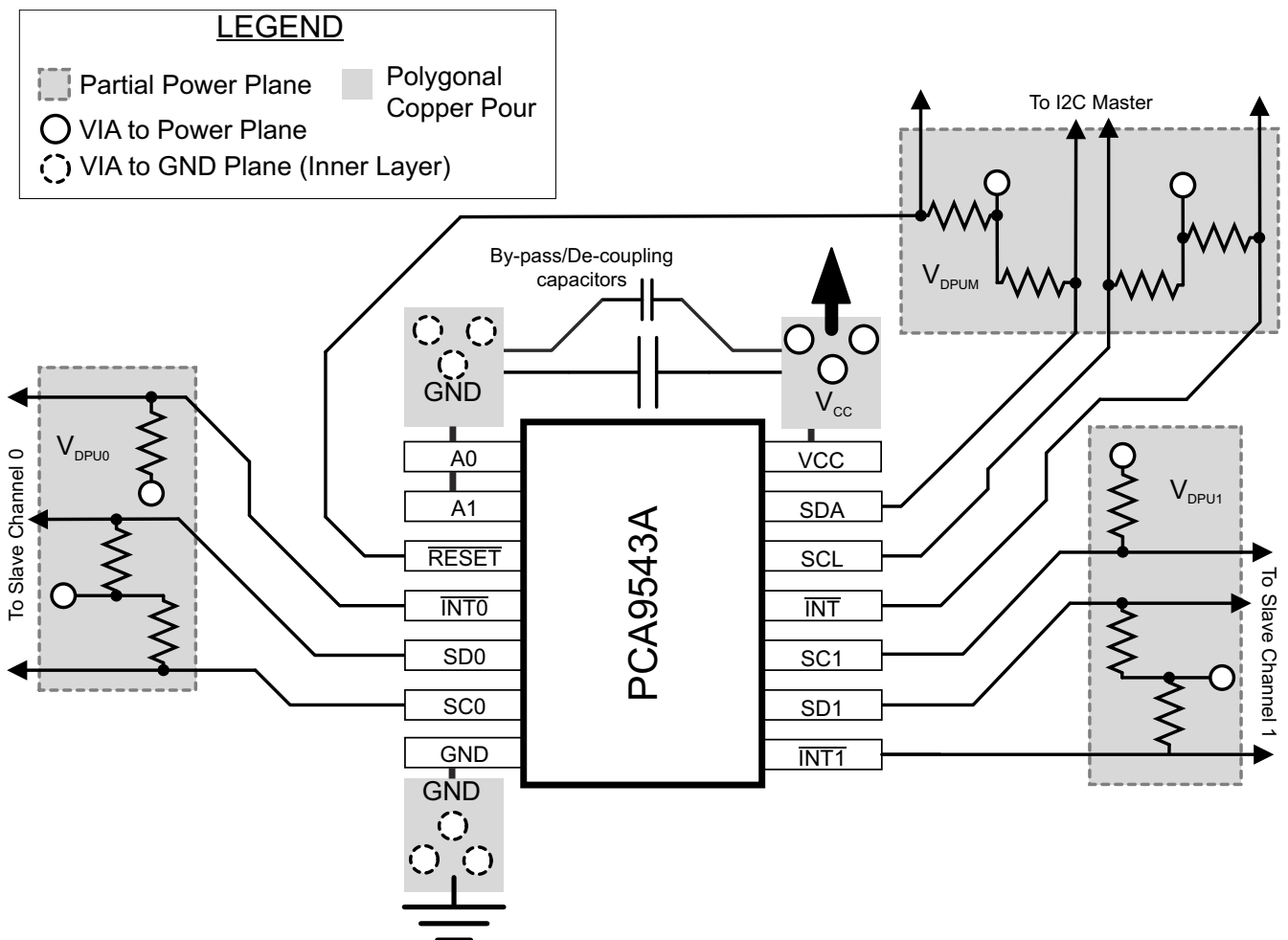

12 Device and Documentation Support

12.1 Receiving Notification of Documentation Updates

To receive notification of documentation updates, navigate to the device product folder on ti.com. Click on *Subscribe to updates* to register and receive a weekly digest of any product information that has changed. For change details, review the revision history included in any revised document.

12.2 Support Resources

TI E2E™ [support forums](#) are an engineer's go-to source for fast, verified answers and design help — straight from the experts. Search existing answers or ask your own question to get the quick design help you need.

Linked content is provided "AS IS" by the respective contributors. They do not constitute TI specifications and do not necessarily reflect TI's views; see TI's [Terms of Use](#).

12.3 Trademarks

TI E2E™ is a trademark of Texas Instruments.
All trademarks are the property of their respective owners.

12.4 Electrostatic Discharge Caution



This integrated circuit can be damaged by ESD. Texas Instruments recommends that all integrated circuits be handled with appropriate precautions. Failure to observe proper handling and installation procedures can cause damage.

ESD damage can range from subtle performance degradation to complete device failure. Precision integrated circuits may be more susceptible to damage because very small parametric changes could cause the device not to meet its published specifications.

12.5 Glossary

[TI Glossary](#) This glossary lists and explains terms, acronyms, and definitions.

13 Mechanical, Packaging, and Orderable Information

The following pages include mechanical packaging and orderable information. This information is the most current data available for the designated devices. This data is subject to change without notice and revision of this document. For browser-based versions of this data sheet, refer to the left-hand navigation.

PACKAGING INFORMATION

Orderable Device	Status (1)	Package Type	Package Drawing	Pins	Package Qty	Eco Plan (2)	Lead finish/ Ball material (6)	MSL Peak Temp (3)	Op Temp (°C)	Device Marking (4/5)	Samples
PCA9543ADR	ACTIVE	SOIC	D	14	2500	RoHS & Green	NIPDAU	Level-1-260C-UNLIM	-40 to 85	PCA9543A	Samples
PCA9543APWR	ACTIVE	TSSOP	PW	14	2000	RoHS & Green	NIPDAU	Level-1-260C-UNLIM	-40 to 85	PD543A	Samples
PCA9543APWRG4	ACTIVE	TSSOP	PW	14	2000	RoHS & Green	NIPDAU	Level-1-260C-UNLIM	-40 to 85	PD543A	Samples

(1) The marketing status values are defined as follows:

ACTIVE: Product device recommended for new designs.

LIFEBUY: TI has announced that the device will be discontinued, and a lifetime-buy period is in effect.

NRND: Not recommended for new designs. Device is in production to support existing customers, but TI does not recommend using this part in a new design.

PREVIEW: Device has been announced but is not in production. Samples may or may not be available.

OBSOLETE: TI has discontinued the production of the device.

(2) **RoHS:** TI defines "RoHS" to mean semiconductor products that are compliant with the current EU RoHS requirements for all 10 RoHS substances, including the requirement that RoHS substance do not exceed 0.1% by weight in homogeneous materials. Where designed to be soldered at high temperatures, "RoHS" products are suitable for use in specified lead-free processes. TI may reference these types of products as "Pb-Free".

RoHS Exempt: TI defines "RoHS Exempt" to mean products that contain lead but are compliant with EU RoHS pursuant to a specific EU RoHS exemption.

Green: TI defines "Green" to mean the content of Chlorine (Cl) and Bromine (Br) based flame retardants meet JS709B low halogen requirements of <=1000ppm threshold. Antimony trioxide based flame retardants must also meet the <=1000ppm threshold requirement.

(3) MSL, Peak Temp. - The Moisture Sensitivity Level rating according to the JEDEC industry standard classifications, and peak solder temperature.

(4) There may be additional marking, which relates to the logo, the lot trace code information, or the environmental category on the device.

(5) Multiple Device Markings will be inside parentheses. Only one Device Marking contained in parentheses and separated by a "~" will appear on a device. If a line is indented then it is a continuation of the previous line and the two combined represent the entire Device Marking for that device.

(6) Lead finish/Ball material - Orderable Devices may have multiple material finish options. Finish options are separated by a vertical ruled line. Lead finish/Ball material values may wrap to two lines if the finish value exceeds the maximum column width.

Important Information and Disclaimer:The information provided on this page represents TI's knowledge and belief as of the date that it is provided. TI bases its knowledge and belief on information provided by third parties, and makes no representation or warranty as to the accuracy of such information. Efforts are underway to better integrate information from third parties. TI has taken and continues to take reasonable steps to provide representative and accurate information but may not have conducted destructive testing or chemical analysis on incoming materials and chemicals. TI and TI suppliers consider certain information to be proprietary, and thus CAS numbers and other limited information may not be available for release.

In no event shall TI's liability arising out of such information exceed the total purchase price of the TI part(s) at issue in this document sold by TI to Customer on an annual basis.

TAPE AND REEL INFORMATION

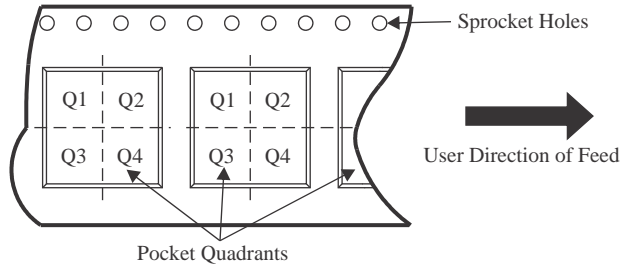
QUADRANT ASSIGNMENTS FOR PIN 1 ORIENTATION IN TAPE

*All dimensions are nominal

Device	Package Type	Package Drawing	Pins	SPQ	Reel Diameter (mm)	Reel Width W1 (mm)	A0 (mm)	B0 (mm)	K0 (mm)	P1 (mm)	W (mm)	Pin1 Quadrant
PCA9543ADR	SOIC	D	14	2500	330.0	16.4	6.5	9.0	2.1	8.0	16.0	Q1
PCA9543APWR	TSSOP	PW	14	2000	330.0	12.4	6.9	5.6	1.6	8.0	12.0	Q1
PCA9543APWR	TSSOP	PW	14	2000	330.0	12.4	6.9	5.6	1.6	8.0	12.0	Q1

TAPE AND REEL BOX DIMENSIONS



*All dimensions are nominal

Device	Package Type	Package Drawing	Pins	SPQ	Length (mm)	Width (mm)	Height (mm)
PCA9543ADR	SOIC	D	14	2500	356.0	356.0	35.0
PCA9543APWR	TSSOP	PW	14	2000	356.0	356.0	35.0
PCA9543APWR	TSSOP	PW	14	2000	356.0	356.0	35.0

D (R-PDSO-G14)

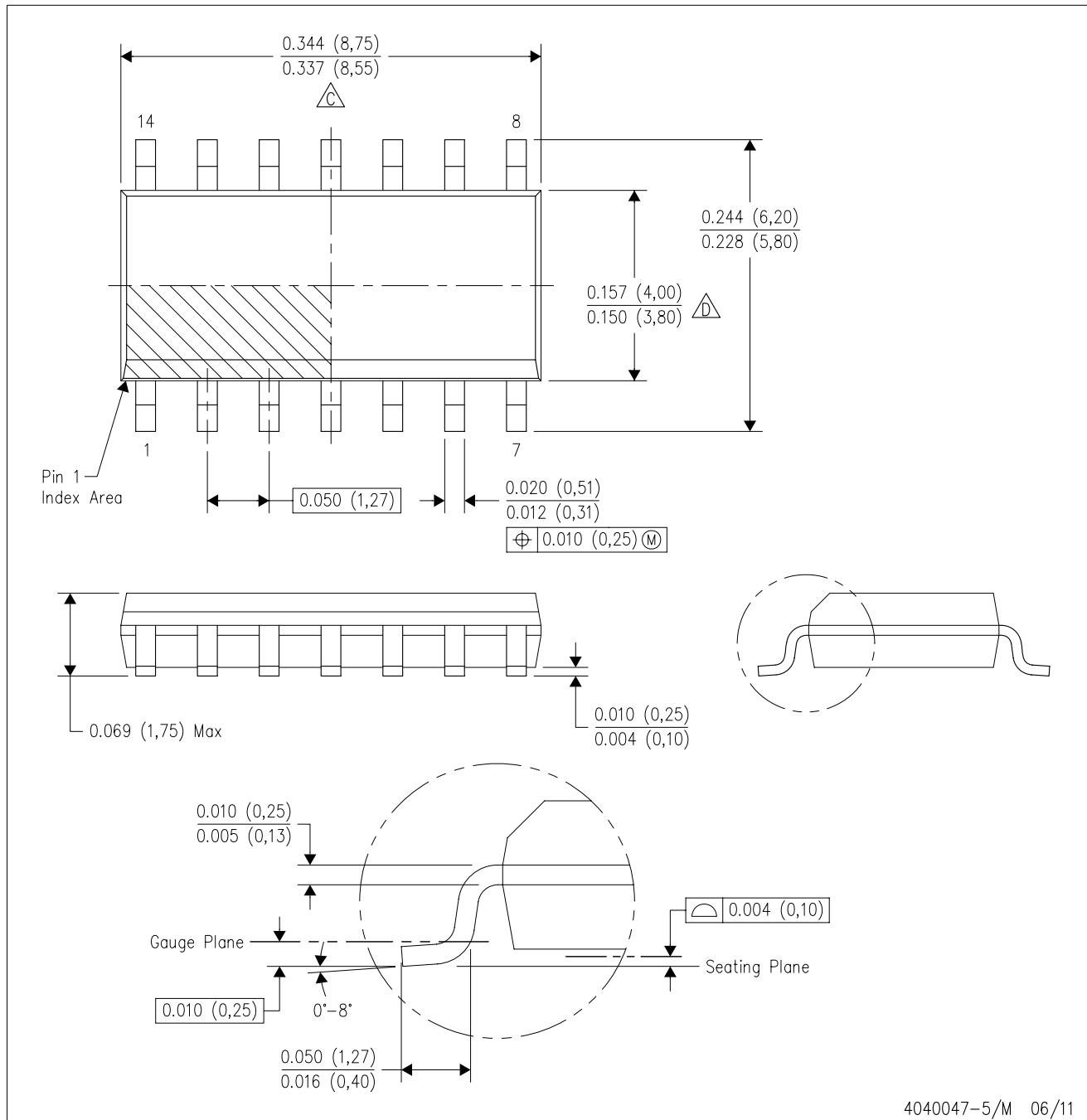
PLASTIC SMALL OUTLINE



- NOTES:
- A. All linear dimensions are in inches (millimeters).
 - B. This drawing is subject to change without notice.
 -  Body length does not include mold flash, protrusions, or gate burrs. Mold flash, protrusions, or gate burrs shall not exceed 0.006 (0,15) each side.
 -  Body width does not include interlead flash. Interlead flash shall not exceed 0.017 (0,43) each side.
 - E. Reference JEDEC MS-012 variation AB.

D (R-PDSO-G14)

PLASTIC SMALL OUTLINE

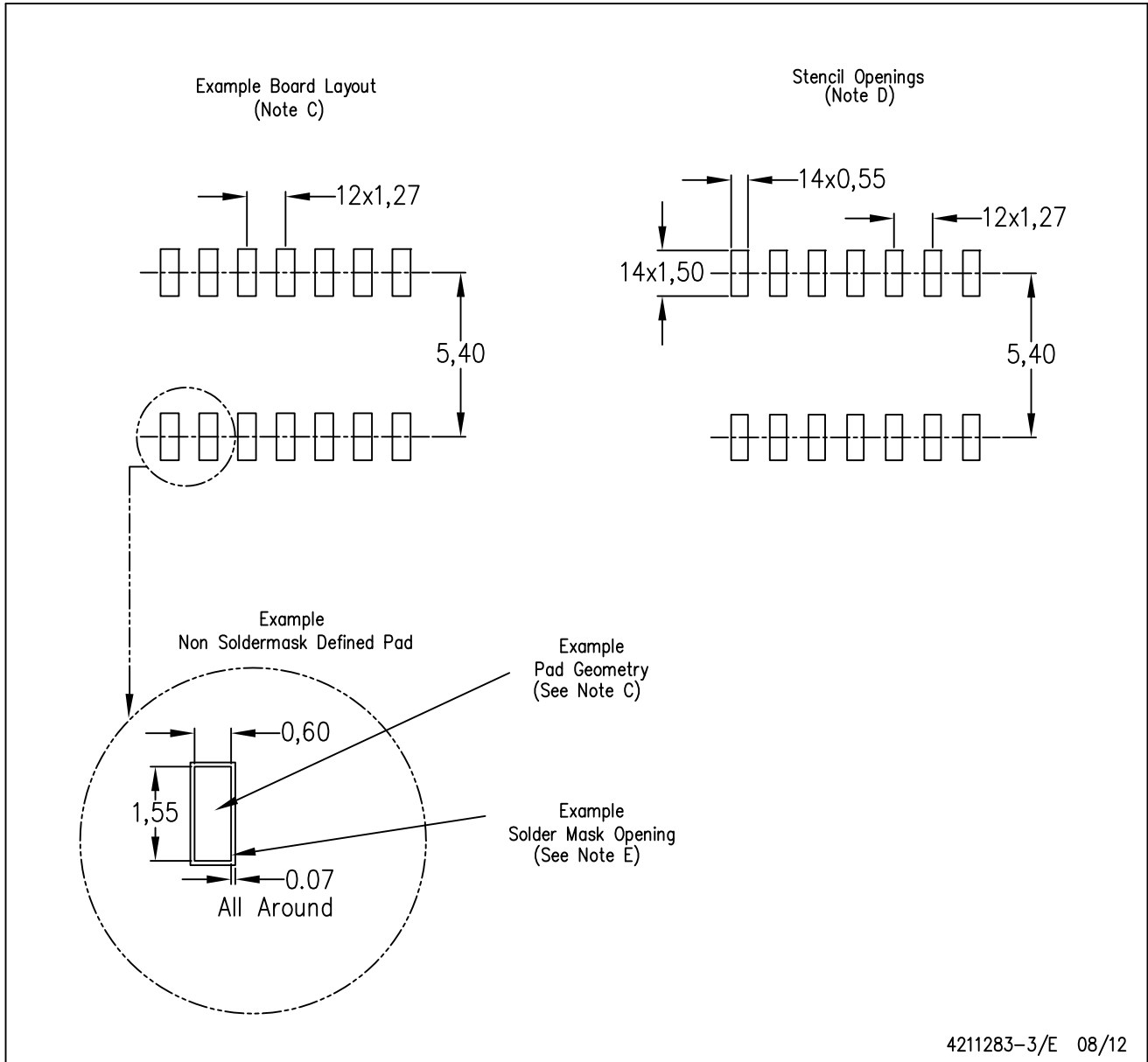

- NOTES:
- A. All linear dimensions are in millimeters.
 - B. This drawing is subject to change without notice.
 - C. Publication IPC-7351 is recommended for alternate designs.
 - D. Laser cutting apertures with trapezoidal walls and also rounding corners will offer better paste release. Customers should contact their board assembly site for stencil design recommendations. Refer to IPC-7525 for other stencil recommendations.
 - E. Customers should contact their board fabrication site for solder mask tolerances between and around signal pads.

PW (R-PDSO-G14)

PLASTIC SMALL OUTLINE



- NOTES:
- All linear dimensions are in millimeters.
 - This drawing is subject to change without notice.
 - Publication IPC-7351 is recommended for alternate designs.
 - Laser cutting apertures with trapezoidal walls and also rounding corners will offer better paste release. Customers should contact their board assembly site for stencil design recommendations. Refer to IPC-7525 for other stencil recommendations.
 - Customers should contact their board fabrication site for solder mask tolerances between and around signal pads.

IMPORTANT NOTICE AND DISCLAIMER

TI PROVIDES TECHNICAL AND RELIABILITY DATA (INCLUDING DATA SHEETS), DESIGN RESOURCES (INCLUDING REFERENCE DESIGNS), APPLICATION OR OTHER DESIGN ADVICE, WEB TOOLS, SAFETY INFORMATION, AND OTHER RESOURCES "AS IS" AND WITH ALL FAULTS, AND DISCLAIMS ALL WARRANTIES, EXPRESS AND IMPLIED, INCLUDING WITHOUT LIMITATION ANY IMPLIED WARRANTIES OF MERCHANTABILITY, FITNESS FOR A PARTICULAR PURPOSE OR NON-INFRINGEMENT OF THIRD PARTY INTELLECTUAL PROPERTY RIGHTS.

These resources are intended for skilled developers designing with TI products. You are solely responsible for (1) selecting the appropriate TI products for your application, (2) designing, validating and testing your application, and (3) ensuring your application meets applicable standards, and any other safety, security, regulatory or other requirements.

These resources are subject to change without notice. TI grants you permission to use these resources only for development of an application that uses the TI products described in the resource. Other reproduction and display of these resources is prohibited. No license is granted to any other TI intellectual property right or to any third party intellectual property right. TI disclaims responsibility for, and you will fully indemnify TI and its representatives against, any claims, damages, costs, losses, and liabilities arising out of your use of these resources.

TI's products are provided subject to [TI's Terms of Sale](#) or other applicable terms available either on [ti.com](https://www.ti.com) or provided in conjunction with such TI products. TI's provision of these resources does not expand or otherwise alter TI's applicable warranties or warranty disclaimers for TI products.

TI objects to and rejects any additional or different terms you may have proposed.

Mailing Address: Texas Instruments, Post Office Box 655303, Dallas, Texas 75265
Copyright © 2024, Texas Instruments Incorporated

Looking for pricing, stock, or lifecycle information?

Click below to explore more details on WIN SOURCE:

 [View PCA9543ADG4](#) on WIN SOURCE

 [Texas Instruments](#) Information

Optimize Your Supply Chain with WIN SOURCE Solutions

-  Global Sourcing Solution
-  Obsolete Management
-  Cost Control Management
-  Shortage Management
-  Alternative Solution
-  Excess Inventory Management