



THE DATASHEET OF TRS232DR



DUAL RS-232 DRIVER/RECEIVER WITH IEC61000-4-2 PROTECTION

FEATURES

- Meets or Exceeds TIA/RS-232-F and ITU Recommendation V.28
- Operates From a Single 5-V Power Supply With 1.0- μ F Charge-Pump Capacitors
- Operates up to 120 kbit/s
- Two Drivers and Two Receivers
- \pm 30-V Input Levels
- Low Supply Current . . . 8 mA Typical
- ESD Protection Exceeds JESD22
 - 2000-V Human-Body Model (HBM) (A114-A)
- Upgrade With Improved ESD (15-kV HBM) and 0.1- μ F Charge-Pump Capacitors Is Available With the TRS202

APPLICATIONS

- TIA/RS-232-F
- Battery-Powered Systems
- Terminals
- Modems
- Computers

DESCRIPTION/ORDERING INFORMATION

The TRS232 is a dual driver/receiver that includes a capacitive voltage generator to supply TIA/RS-232-F voltage levels from a single 5-V supply. Each receiver converts TIA/RS-232-F inputs to 5-V TTL/CMOS levels. This receiver has a typical threshold of 1.3 V, a typical hysteresis of 0.5 V, and can accept \pm 30-V inputs. Each driver converts TTL/CMOS input levels into TIA/RS-232-F levels. The driver, receiver, and voltage-generator functions are available as cells in the Texas Instruments LinASIC™ library.

D, DW, N, NS, OR PW PACKAGE
(TOP VIEW)

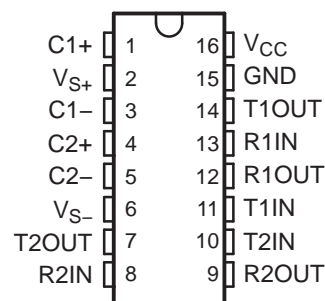

Please be aware that an important notice concerning availability, standard warranty, and use in critical applications of Texas Instruments semiconductor products and disclaimers thereto appears at the end of this data sheet.

LinASIC is a trademark of Texas Instruments.

ORDERING INFORMATION

T _A	PACKAGE ⁽¹⁾⁽²⁾		ORDERABLE PART NUMBER	TOP-SIDE MARKING	
0°C to 70°C	PDIP – N	Tube of 25	TRS232CN	TRS232CN	
	SOIC – D	Tube of 40	TRS232CD	TRS232C	
		Reel of 2500	TRS232CDR		
	SOIC – DW	Tube of 40	TRS232CDW	TRS232C	
		Reel of 2000	TRS232CDWR		
	SOP – NS	Reel of 2000	TRS232CNSR	TRS232C	
	TSSOP – PW	Tube of 25	TRS232CPW	TRS232C	
		Reel of 2000	TRS232CPWR		
	–40°C to 85°C	PDIP – N	Tube of 25	TRS232IN	TRS232IN
		SOIC – D	Tube of 40	TRS232ID	TRS232I
Reel of 2500			TRS232IDR		
SOIC – DW		Tube of 40	TRS232IDW	TRS232I	
		Reel of 2000	TRS232IDWR		
SOP – NS		Reel of 2000	TRS232INSR	TRS232I	
TSSOP – PW		Tube of 25	TRS232IPW	TRS232I	
		Reel of 2000	TRS232IPWR		

(1) Package drawings, thermal data, and symbolization are available at www.ti.com/packaging.

(2) For the most current package and ordering information, see the Package Option Addendum at the end of this document, or see the TI website at www.ti.com.

FUNCTION TABLES
Each Driver⁽¹⁾

INPUT TnIN	OUTPUT TnOUT
L	H
H	L

(1) H = high level, L = low level

Each Receiver⁽¹⁾

INPUT RnIN	OUTPUT RnOUT
L	H
H	L

(1) H = high level, L = low level

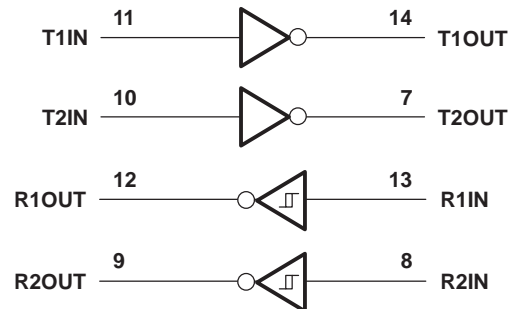
LOGIC DIAGRAM (POSITIVE LOGIC)

Absolute Maximum Ratings⁽¹⁾

over operating free-air temperature range (unless otherwise noted)

		MIN	MAX	UNIT
V _{CC}	Input supply voltage range ⁽²⁾	–0.3	6	V
V _{S+}	Positive-output supply voltage range	V _{CC} – 0.3	15	V
V _{S–}	Negative-output supply voltage range	–0.3	–15	V
V _I	Input voltage range	Driver	V _{CC} + 0.3	V
		Receiver	±30	
V _O	Output voltage range	T1OUT, T2OUT	V _{S–} – 0.3	V
		R1OUT, R2OUT	V _{CC} + 0.3	
	Short-circuit duration		Unlimited	
θ _{JA}	Package thermal impedance ⁽³⁾⁽⁴⁾	D package		°C/W
		DW package		
		N package		
		NS package		
		PW package		
T _J	Operating virtual junction temperature		150	°C
T _{stg}	Storage temperature range	–65	150	°C

- (1) Stresses beyond those listed under "absolute maximum ratings" may cause permanent damage to the device. These are stress ratings only, and functional operation of the device at these or any other conditions beyond those indicated under "recommended operating conditions" is not implied. Exposure to absolute-maximum-rated conditions for extended periods may affect device reliability.
- (2) All voltages are with respect to network GND.
- (3) Maximum power dissipation is a function of T_{J(max)}, θ_{JA}, and T_A. The maximum allowable power dissipation at any allowable ambient temperature is P_D = (T_{J(max)} – T_A)/θ_{JA}. Operating at the absolute maximum T_J of 150°C can affect reliability.
- (4) The package thermal impedance is calculated in accordance with JESD 51-7.

Recommended Operating Conditions

		MIN	NOM	MAX	UNIT
V _{CC}	Supply voltage	4.5	5	5.5	V
V _{IH}	High-level input voltage	T1IN, T2IN	2		V
V _{IL}	Low-level input voltage	T1IN, T2IN		0.8	V
	Receiver input voltage	R1IN, R2IN		±30	
T _A	Operating free-air temperature	TRS232C	0	70	°C
		TRS232I	–40	85	

Electrical Characteristics⁽¹⁾

over recommended ranges of supply voltage and operating free-air temperature (unless otherwise noted) (see [Figure 4](#))

PARAMETER		TEST CONDITIONS		MIN	TYP ⁽²⁾	MAX	UNIT
I _{CC}	Supply current	V _{CC} = 5.5 V,	All outputs open, T _A = 25°C		8	10	mA

- (1) Test conditions are C1–C4 = 1 μF at V_{CC} = 5 V ± 0.5 V.
- (2) All typical values are at V_{CC} = 5 V and T_A = 25°C.

DRIVER SECTION

Electrical Characteristics⁽¹⁾

over recommended ranges of supply voltage and operating free-air temperature range

PARAMETER		TEST CONDITIONS	MIN	TYP ⁽²⁾	MAX	UNIT
V _{OH}	High-level output voltage	T1OUT, T2OUT R _L = 3 kΩ to GND	5	7		V
V _{OL}	Low-level output voltage ⁽³⁾	T1OUT, T2OUT R _L = 3 kΩ to GND		–7	–5	V
r _o	Output resistance	T1OUT, T2OUT V _{S+} = V _{S–} = 0, V _O = ±2 V	300			Ω
I _{OS} ⁽⁴⁾	Short-circuit output current	T1OUT, T2OUT V _{CC} = 5.5 V, V _O = 0		±10		mA
I _{IS}	Short-circuit input current	T1IN, T2IN V _I = 0			200	μA

(1) Test conditions are C1–C4 = 1 μF at V_{CC} = 5 V ± 0.5 V.

(2) All typical values are at V_{CC} = 5 V and T_A = 25°C.

(3) The algebraic convention, in which the least-positive (most negative) value is designated minimum, is used in this data sheet for logic voltage levels only.

(4) Not more than one output should be shorted at a time.

Switching Characteristics⁽¹⁾

V_{CC} = 5 V, T_A = 25°C

PARAMETER		TEST CONDITIONS	MIN	TYP	MAX	UNIT
SR	Driver slew rate	R _L = 3 kΩ to 7 kΩ, See Figure 2			30	V/μs
SR(t)	Driver transition region slew rate	See Figure 3		3		V/μs
	Data rate	One TnOUT switching		120		kbit/s

(1) Test conditions are C1–C4 = 1 μF at V_{CC} = 5 V ± 0.5 V.

RECEIVER SECTION

Electrical Characteristics⁽¹⁾

over recommended ranges of supply voltage and operating free-air temperature range

PARAMETER		TEST CONDITIONS	MIN	TYP ⁽²⁾	MAX	UNIT
V _{OH}	High-level output voltage	R1OUT, R2OUT I _{OH} = -1 mA	3.5			V
V _{OL}	Low-level output voltage ⁽³⁾	R1OUT, R2OUT I _{OL} = 3.2 mA			0.4	V
V _{IT+}	Receiver positive-going input threshold voltage	R1IN, R2IN V _{CC} = 5 V, T _A = 25°C		1.7	2.4	V
V _{IT-}	Receiver negative-going input threshold voltage	R1IN, R2IN V _{CC} = 5 V, T _A = 25°C	0.8	1.2		V
V _{hys}	Input hysteresis voltage	R1IN, R2IN V _{CC} = 5 V	0.2	0.5	1	V
r _i	Receiver input resistance	R1IN, R2IN V _{CC} = 5 V, T _A = 25°C	3	5	7	kΩ

(1) Test conditions are C1–C4 = 1 μF at V_{CC} = 5 V ± 0.5 V.

(2) All typical values are at V_{CC} = 5 V and T_A = 25°C.

(3) The algebraic convention, in which the least-positive (most negative) value is designated minimum, is used in this data sheet for logic voltage levels only.

Switching Characteristics⁽¹⁾

V_{CC} = 5 V, T_A = 25°C (see [Figure 1](#))

PARAMETER		TYP	UNIT
t _{PLH(R)}	Receiver propagation delay time, low- to high-level output	500	ns
t _{PHL(R)}	Receiver propagation delay time, high- to low-level output	500	ns

(1) Test conditions are C1–C4 = 1 μF at V_{CC} = 5 V ± 0.5 V.

PARAMETER MEASUREMENT INFORMATION

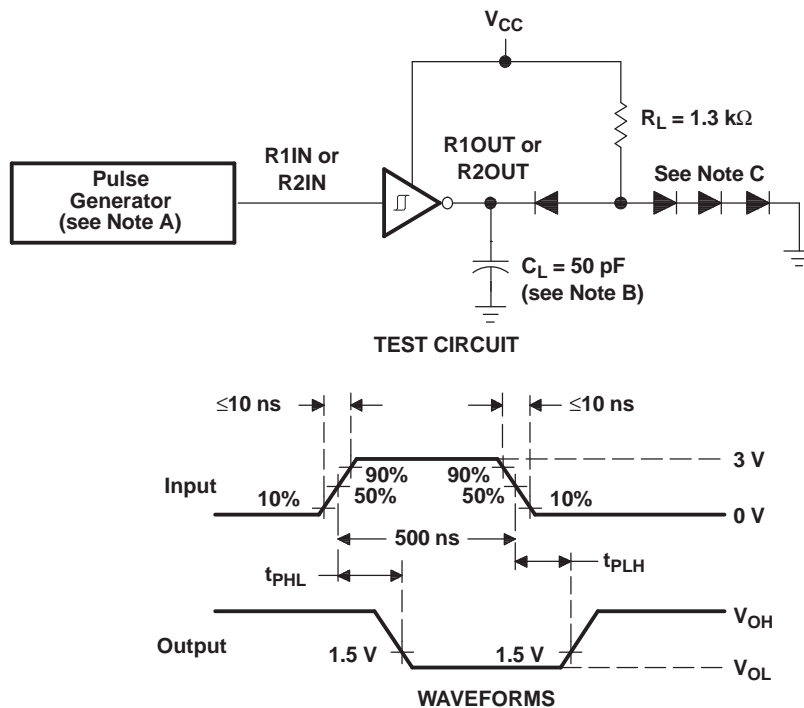

- A. The pulse generator has the following characteristics: $Z_O = 50 \Omega$, duty cycle $\leq 50\%$.
- B. C_L includes probe and jig capacitance.
- C. All diodes are 1N3064 or equivalent.

Figure 1. Receiver Test Circuit and Waveforms for t_{PHL} and t_{PLH} Measurements

PARAMETER MEASUREMENT INFORMATION (continued)

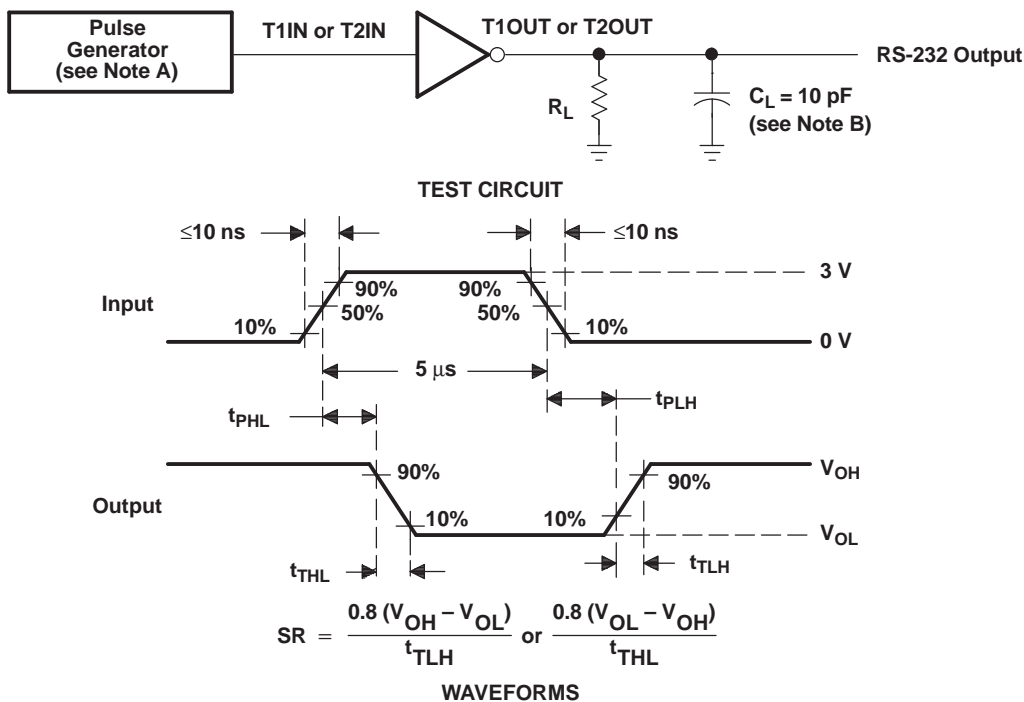

- A. The pulse generator has the following characteristics: $Z_O = 50 \Omega$, duty cycle $\leq 50\%$.
- B. C_L includes probe and jig capacitance.

Figure 2. Driver Test Circuit and Waveforms for t_{PHL} and t_{PLH} Measurements (5- μs Input)

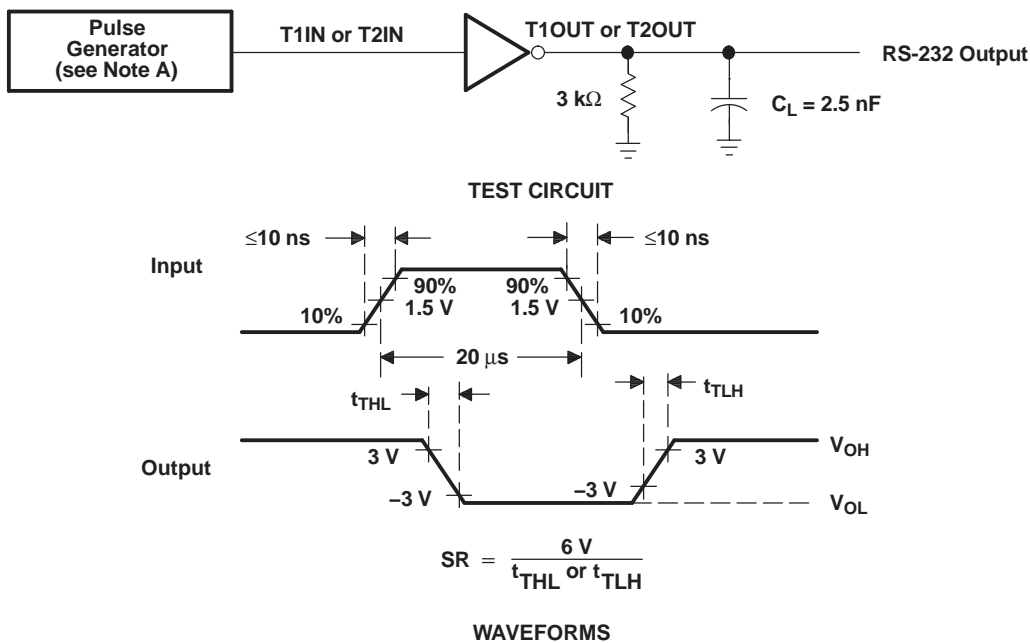

- A. The pulse generator has the following characteristics: $Z_O = 50 \Omega$, duty cycle $\leq 50\%$.

Figure 3. Test Circuit and Waveforms for t_{THL} and t_{TLH} Measurements (20- μs Input)

APPLICATION INFORMATION

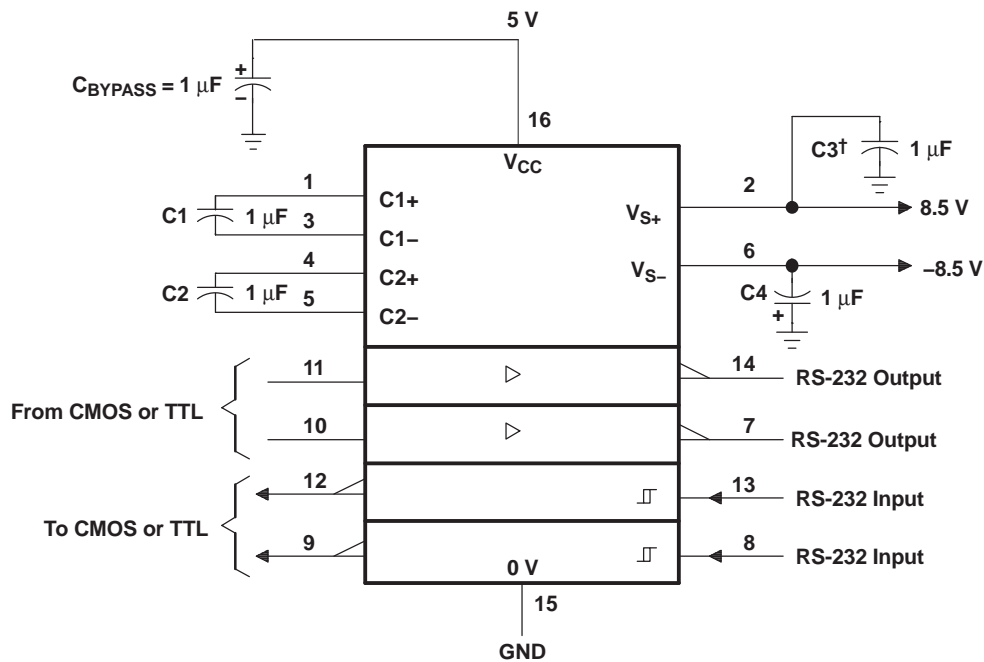

† C3 can be connected to V_{CC} or GND.

- A. Resistor values shown are nominal.
- B. Nonpolarized ceramic capacitors are acceptable. If polarized tantalum or electrolytic capacitors are used, they should be connected as shown. In addition to the 1-µF capacitors shown, the TRS202 can operate with 0.1-µF capacitors.

Figure 4. Typical Operating Circuit

PACKAGING INFORMATION

Orderable Device	Status (1)	Package Type	Package Drawing	Pins	Package Qty	Eco Plan (2)	Lead finish/ Ball material (6)	MSL Peak Temp (3)	Op Temp (°C)	Device Marking (4/5)	Samples
TRS232ID	LIFEBUY	SOIC	D	16	40	RoHS & Green	NIPDAU	Level-1-260C-UNLIM	-40 to 85	TRS232I	

(1) The marketing status values are defined as follows:

ACTIVE: Product device recommended for new designs.

LIFEBUY: TI has announced that the device will be discontinued, and a lifetime-buy period is in effect.

NRND: Not recommended for new designs. Device is in production to support existing customers, but TI does not recommend using this part in a new design.

PREVIEW: Device has been announced but is not in production. Samples may or may not be available.

OBSELETE: TI has discontinued the production of the device.

(2) **RoHS:** TI defines "RoHS" to mean semiconductor products that are compliant with the current EU RoHS requirements for all 10 RoHS substances, including the requirement that RoHS substance do not exceed 0.1% by weight in homogeneous materials. Where designed to be soldered at high temperatures, "RoHS" products are suitable for use in specified lead-free processes. TI may reference these types of products as "Pb-Free".

RoHS Exempt: TI defines "RoHS Exempt" to mean products that contain lead but are compliant with EU RoHS pursuant to a specific EU RoHS exemption.

Green: TI defines "Green" to mean the content of Chlorine (Cl) and Bromine (Br) based flame retardants meet JS709B low halogen requirements of <=1000ppm threshold. Antimony trioxide based flame retardants must also meet the <=1000ppm threshold requirement.

(3) MSL, Peak Temp. - The Moisture Sensitivity Level rating according to the JEDEC industry standard classifications, and peak solder temperature.

(4) There may be additional marking, which relates to the logo, the lot trace code information, or the environmental category on the device.

(5) Multiple Device Markings will be inside parentheses. Only one Device Marking contained in parentheses and separated by a "-" will appear on a device. If a line is indented then it is a continuation of the previous line and the two combined represent the entire Device Marking for that device.

(6) Lead finish/Ball material - Orderable Devices may have multiple material finish options. Finish options are separated by a vertical ruled line. Lead finish/Ball material values may wrap to two lines if the finish value exceeds the maximum column width.

Important Information and Disclaimer:The information provided on this page represents TI's knowledge and belief as of the date that it is provided. TI bases its knowledge and belief on information provided by third parties, and makes no representation or warranty as to the accuracy of such information. Efforts are underway to better integrate information from third parties. TI has taken and continues to take reasonable steps to provide representative and accurate information but may not have conducted destructive testing or chemical analysis on incoming materials and chemicals. TI and TI suppliers consider certain information to be proprietary, and thus CAS numbers and other limited information may not be available for release.

In no event shall TI's liability arising out of such information exceed the total purchase price of the TI part(s) at issue in this document sold by TI to Customer on an annual basis.

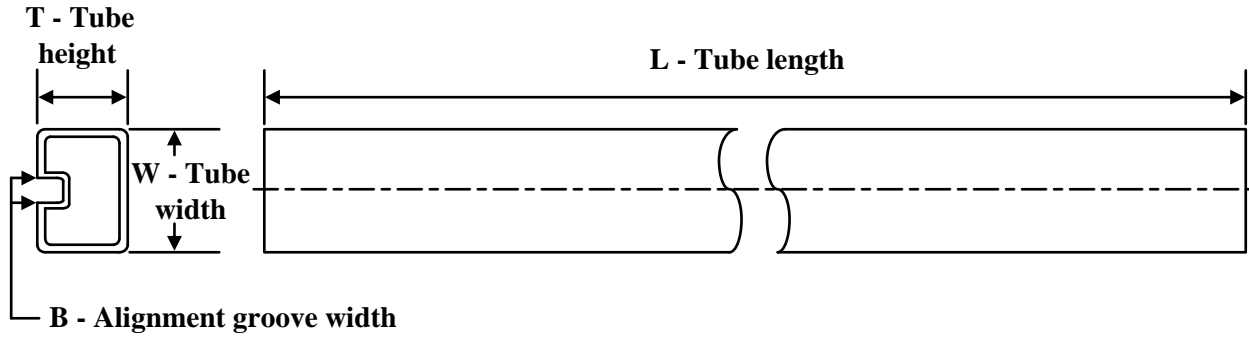
TUBE

*All dimensions are nominal

Device	Package Name	Package Type	Pins	SPQ	L (mm)	W (mm)	T (μm)	B (mm)
TRS232ID	D	SOIC	16	40	507	8	3940	4.32

D (R-PDSO-G16)

PLASTIC SMALL OUTLINE



- NOTES:
- A. All linear dimensions are in inches (millimeters).
 - B. This drawing is subject to change without notice.
 - C. Body length does not include mold flash, protrusions, or gate burrs. Mold flash, protrusions, or gate burrs shall not exceed 0.006 (0,15) each side.
 - D. Body width does not include interlead flash. Interlead flash shall not exceed 0.017 (0,43) each side.
 - E. Reference JEDEC MS-012 variation AC.

D (R-PDSO-G16)

PLASTIC SMALL OUTLINE



- NOTES:
- All linear dimensions are in millimeters.
 - This drawing is subject to change without notice.
 - Publication IPC-7351 is recommended for alternate designs.
 - Laser cutting apertures with trapezoidal walls and also rounding corners will offer better paste release. Customers should contact their board assembly site for stencil design recommendations. Refer to IPC-7525 for other stencil recommendations.
 - Customers should contact their board fabrication site for solder mask tolerances between and around signal pads.

IMPORTANT NOTICE AND DISCLAIMER

TI PROVIDES TECHNICAL AND RELIABILITY DATA (INCLUDING DATA SHEETS), DESIGN RESOURCES (INCLUDING REFERENCE DESIGNS), APPLICATION OR OTHER DESIGN ADVICE, WEB TOOLS, SAFETY INFORMATION, AND OTHER RESOURCES "AS IS" AND WITH ALL FAULTS, AND DISCLAIMS ALL WARRANTIES, EXPRESS AND IMPLIED, INCLUDING WITHOUT LIMITATION ANY IMPLIED WARRANTIES OF MERCHANTABILITY, FITNESS FOR A PARTICULAR PURPOSE OR NON-INFRINGEMENT OF THIRD PARTY INTELLECTUAL PROPERTY RIGHTS.

These resources are intended for skilled developers designing with TI products. You are solely responsible for (1) selecting the appropriate TI products for your application, (2) designing, validating and testing your application, and (3) ensuring your application meets applicable standards, and any other safety, security, regulatory or other requirements.

These resources are subject to change without notice. TI grants you permission to use these resources only for development of an application that uses the TI products described in the resource. Other reproduction and display of these resources is prohibited. No license is granted to any other TI intellectual property right or to any third party intellectual property right. TI disclaims responsibility for, and you will fully indemnify TI and its representatives against, any claims, damages, costs, losses, and liabilities arising out of your use of these resources.

TI's products are provided subject to [TI's Terms of Sale](#) or other applicable terms available either on [ti.com](https://www.ti.com) or provided in conjunction with such TI products. TI's provision of these resources does not expand or otherwise alter TI's applicable warranties or warranty disclaimers for TI products.

TI objects to and rejects any additional or different terms you may have proposed.

Mailing Address: Texas Instruments, Post Office Box 655303, Dallas, Texas 75265
Copyright © 2023, Texas Instruments Incorporated

Looking for pricing, stock, or lifecycle information?

Click below to explore more details on WIN SOURCE:

 [View TRS232DR](#) on WIN SOURCE

 [Texas Instruments](#) Information

Optimize Your Supply Chain with WIN SOURCE Solutions

-  Global Sourcing Solution
-  Obsolete Management
-  Cost Control Management
-  Shortage Management
-  Alternative Solution
-  Excess Inventory Management