



**THE DATASHEET OF  
CY14E256L-SZ45XC**



## Features

- 25 ns, 35 ns, and 45 ns Access Times
- Pin Compatible with STK14C88
- Hands Off Automatic STORE on Power Down with External 68  $\mu$ F Capacitor
- STORE to QuantumTrap Nonvolatile Elements is Initiated by Software, Hardware, or AutoStore on Power Down
- RECALL to SRAM Initiated by Software or Power Up
- Unlimited READ, WRITE, and RECALL Cycles
- 1,000,000 STORE Cycles to QuantumTrap
- 100 Year Data Retention to QuantumTrap
- Single 5V $\pm$ 10% Operation
- Commercial and Industrial Temperature
- 32-Pin SOIC Package (RoHS Compliance)
- CDIP (300 mil) Package

## Functional Description

The Cypress CY14E256L is a fast static RAM with a nonvolatile element in each memory cell. The embedded nonvolatile elements incorporate QuantumTrap technology producing the world's most reliable nonvolatile memory. The SRAM provides unlimited read and write cycles, while independent, nonvolatile data resides in the highly reliable QuantumTrap cell. Data transfers from the SRAM to the nonvolatile elements (the STORE operation) takes place automatically at power down. On power up, data is restored to the SRAM (the RECALL operation) from the nonvolatile memory. Both the STORE and RECALL operations are also available under software control. A hardware STORE is initiated with the HSB pin.

## Logic Block Diagram

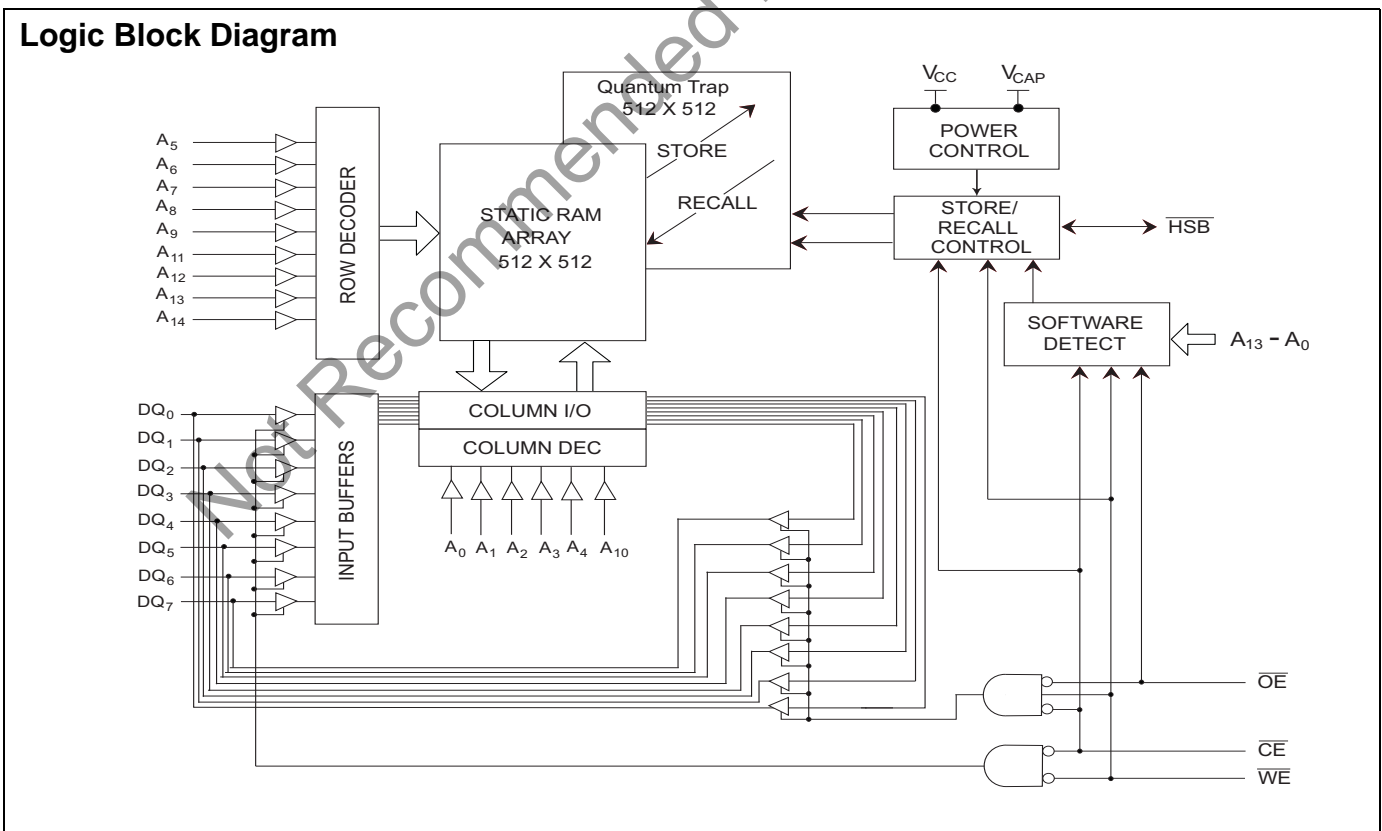

**Contents**

Features .....	1	Best Practices .....	7
Functional Description .....	1	Maximum Ratings .....	8
Logic Block Diagram .....	1	Operating Range .....	8
Contents .....	2	DC Electrical Characteristics .....	8
Pin Configurations .....	3	Data Retention and Endurance .....	9
Device Operation .....	4	Capacitance .....	9
SRAM Read .....	4	Thermal Resistance .....	9
SRAM Write .....	4	AC Test Conditions .....	9
AutoStore Operation .....	4	SRAM Read Cycle .....	10
AutoStore Inhibit mode .....	4	SRAM Write Cycle .....	11
Hardware STORE (HSB) Operation .....	5	AutoStore or Power Up RECALL .....	12
Hardware RECALL (Power Up) .....	5	Software Controlled STORE/RECALL Cycle .....	13
Software STORE .....	5	Switching Waveforms .....	14
Software RECALL .....	5	Part Numbering Nomenclature	
Data Protection .....	6	(Commercial and Industrial) .....	15
Noise Considerations .....	6	Ordering Information .....	15
Hardware Protect .....	6	Document History Page .....	18
Low Average Active Power .....	6	Sales, Solutions, and Legal Information .....	19
Preventing Store .....	6	Worldwide Sales and Design Support .....	19
		Products .....	19

Not Recommended for New Designs

## Pin Configurations

Figure 1. Pin Diagram: 32-Pin SOIC/DIP

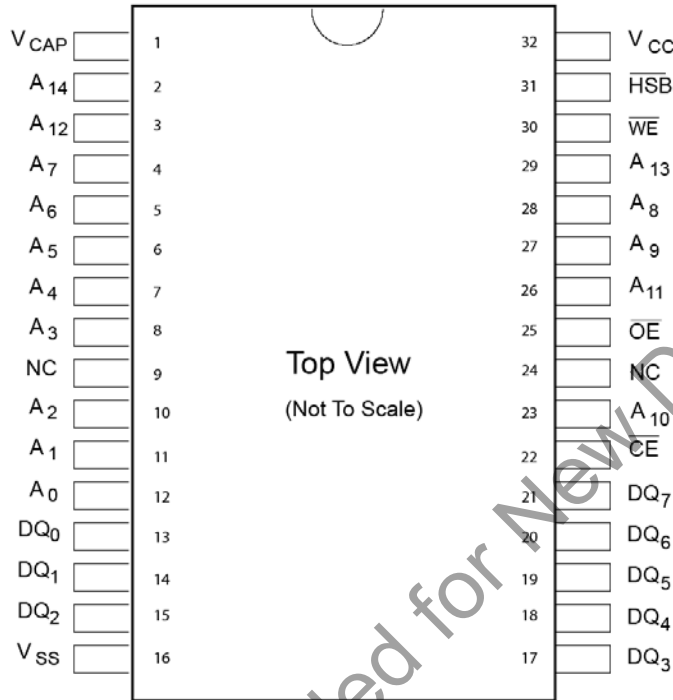

Table 1. Pin Definitions

Pin Name	Alt	I/O Type	Description
A <sub>0</sub> -A <sub>14</sub>		Input	<b>Address Inputs.</b> Used to select one of the 32,768 bytes of the nvSRAM.
DQ <sub>0</sub> -DQ <sub>7</sub>		Input or Output	<b>Bidirectional Data I/O Lines.</b> Used as input or output lines depending on operation.
$\overline{WE}$	$\overline{W}$	Input	<b>Write Enable Input, Active LOW.</b> When the chip is enabled and $\overline{WE}$ is LOW, data on the I/O pins is written to the specific address location.
$\overline{CE}$	$\overline{E}$	Input	<b>Chip Enable Input, Active LOW.</b> When LOW, selects the chip. When HIGH, deselects the chip.
$\overline{OE}$	$\overline{G}$	Input	<b>Output Enable, Active LOW.</b> The active LOW $\overline{OE}$ input enables the data output buffers during read cycles. Deasserting $\overline{OE}$ HIGH causes the I/O pins to tri-state.
V <sub>SS</sub>		Ground	<b>Ground for the Device.</b> The device is connected to ground of the system.
V <sub>CC</sub>		Power Supply	<b>Power Supply Inputs to the Device.</b>
$\overline{HSB}$		Input or Output	<b>Hardware Store Busy (HSB).</b> When LOW, this output indicates a Hardware Store is in progress. When pulled low external to the chip, it initiates a nonvolatile STORE operation. A weak internal pull up resistor keeps this pin high if not connected (connection optional).
V <sub>CAP</sub>		Power Supply	<b>AutoStore Capacitor.</b> Supplies power to nvSRAM during power loss to store data from SRAM to nonvolatile elements.

## Device Operation

The CY14E256L nvSRAM is made up of two functional components paired in the same physical cell. These are an SRAM memory cell and a nonvolatile QuantumTrap cell. The SRAM memory cell operates as a standard fast static RAM. Data in the SRAM is transferred to the nonvolatile cell (the STORE operation) or from the nonvolatile cell to SRAM (the RECALL operation). This unique architecture enables storage and recall of all cells in parallel. During the STORE and RECALL operations, SRAM READ and WRITE operations are inhibited. The CY14E256L supports unlimited reads and writes similar to a typical SRAM. In addition, it provides unlimited RECALL operations from the nonvolatile cells and up to one million STORE operations.

## SRAM Read

The CY14E256L performs a READ cycle whenever  $\overline{CE}$  and  $\overline{OE}$  are LOW while WE and HSB are HIGH. The address specified on pins A<sub>0-14</sub> determines the 32,768 data bytes accessed. When the READ is initiated by an address transition, the outputs are valid after a delay of t<sub>AA</sub> (READ cycle 1). If the READ is initiated by CE or OE, the outputs are valid at t<sub>ACE</sub> or at t<sub>DOE</sub>, whichever is later (READ cycle 2). The data outputs repeatedly respond to address changes within the t<sub>AA</sub> access time without the need for transitions on any control input pins, and remains valid until another address change or until CE or OE is brought HIGH, or WE or HSB is brought LOW.

## SRAM Write

A WRITE cycle is performed whenever  $\overline{CE}$  and  $\overline{WE}$  are LOW and HSB is HIGH. The address inputs must be stable prior to entering the WRITE cycle and must remain stable until either CE or WE goes HIGH at the end of the cycle. The data on the common I/O pins DQ<sub>0-7</sub> are written into the memory if it has valid t<sub>SD</sub> before the end of a WE controlled WRITE or before the end of an CE controlled WRITE. Keep OE HIGH during the entire WRITE cycle to avoid data bus contention on common I/O lines. If OE is left LOW, internal circuitry turns off the output buffers t<sub>HZWE</sub> after WE goes LOW.

## AutoStore Operation

The CY14E256L stores data to nvSRAM using one of three storage operations:

1. Hardware store activated by HSB
2. Software store activated by an address sequence
3. AutoStore on device power down

AutoStore operation is a unique feature of QuantumTrap technology and is enabled by default on the CY14E256L.

During normal operation, the device draws current from V<sub>CC</sub> to charge a capacitor connected to the V<sub>CAP</sub> pin. This stored charge is used by the chip to perform a single STORE operation. If the voltage on the V<sub>CC</sub> pin drops below V<sub>SWITCH</sub>, the part automatically disconnects the V<sub>CAP</sub> pin from V<sub>CC</sub>. A STORE operation is initiated with power provided by the V<sub>CAP</sub> capacitor.

Figure 2 shows the proper connection of the storage capacitor (V<sub>CAP</sub>) for automatic store operation. A charge storage capacitor

having a capacitor of between 68 uF and 220 uF (± 20%) rated at 6V should be provided. The voltage on the V<sub>CAP</sub> pin is driven to 5V by a charge pump internal to the chip. A pull up is placed on WE to hold it inactive during power up.

Figure 2. AutoStore Mode

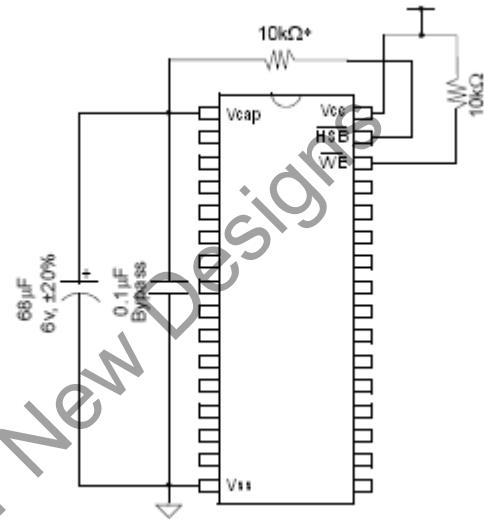

In system power mode, both V<sub>CC</sub> and V<sub>CAP</sub> are connected to the +5V power supply without the 68 uF capacitor. In this mode, the AutoStore function of the CY14E256L operates on the stored system charge as power goes down. The user must, however, guarantee that V<sub>CC</sub> does not drop below 3.6V during the 10 ms STORE cycle.

To reduce unnecessary nonvolatile stores, AutoStore and Hardware Store operations are ignored, unless at least one WRITE operation has taken place since the most recent STORE or RECALL cycle. Software initiated STORE cycles are performed regardless of whether a WRITE operation has taken place. An optional pull up resistor is shown connected to HSB. The HSB signal is monitored by the system to detect if an AutoStore cycle is in progress.

If the power supply drops faster than 20 us/volt before V<sub>CC</sub> reaches V<sub>SWITCH</sub>, then a 2.2 ohm resistor should be connected between V<sub>CC</sub> and the system supply to avoid momentary excess of current between V<sub>CC</sub> and V<sub>CAP</sub>.

## AutoStore Inhibit mode

If an automatic STORE on power loss is not required, then V<sub>CC</sub> is tied to ground and + 5V is applied to V<sub>CAP</sub> (Figure 3). This is the AutoStore Inhibit mode, where the AutoStore function is disabled. If the CY14E256L is operated in this configuration, references to V<sub>CC</sub> are changed to V<sub>CAP</sub> throughout this data sheet. In this mode, STORE operations are triggered through software control or the HSB pin. To enable or disable Autostore using an I/O port pin see "Preventing Store" on page 6. It is not permissible to change between these three options "on the fly".

Figure 3. AutoStore Inhibit Mode

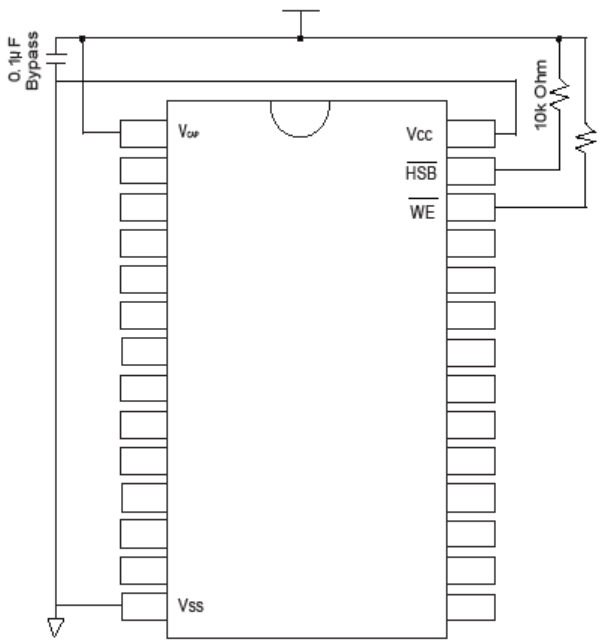

### Hardware STORE (HSB) Operation

The CY14E256L provides the  $\overline{\text{HSB}}$  pin for controlling and acknowledging the STORE operations. The  $\overline{\text{HSB}}$  pin is used to request a hardware STORE cycle. When the  $\overline{\text{HSB}}$  pin is driven LOW, the CY14E256L conditionally initiates a STORE operation after  $t_{\text{DELAY}}$ . An actual STORE cycle only begins if a WRITE to the SRAM takes place since the last STORE or RECALL cycle. The  $\overline{\text{HSB}}$  pin also acts as an open drain driver that is internally driven LOW to indicate a busy condition, while the STORE (initiated by any means) is in progress. Pull up this pin with an external 10K ohm resistor to  $V_{\text{CAP}}$  if  $\overline{\text{HSB}}$  is used as a driver.

SRAM READ and WRITE operations, that are in progress when  $\overline{\text{HSB}}$  is driven LOW by any means, are given time to complete before the STORE operation is initiated. After  $\overline{\text{HSB}}$  goes LOW, the CY14E256L continues SRAM operations for  $t_{\text{DELAY}}$ . During  $t_{\text{DELAY}}$ , multiple SRAM READ operations take place. If a WRITE is in progress when  $\overline{\text{HSB}}$  is pulled LOW, it allows a time,  $t_{\text{DELAY}}$  to complete. However, any SRAM WRITE cycles requested after  $\overline{\text{HSB}}$  goes LOW are inhibited until  $\overline{\text{HSB}}$  returns HIGH.

During any STORE operation, regardless of how it is initiated, the CY14E256L continues to drive the  $\overline{\text{HSB}}$  pin LOW, releasing it only when the STORE is complete. After completing the STORE operation, the CY14E256L remains disabled until the  $\overline{\text{HSB}}$  pin returns HIGH.

If  $\overline{\text{HSB}}$  is not used, it is left unconnected.

### Hardware RECALL (Power Up)

During power up or after any low power condition ( $V_{\text{CC}} < V_{\text{RESET}}$ ), an internal RECALL request is latched. When  $V_{\text{CC}}$  once again exceeds the sense voltage of  $V_{\text{SWITCH}}$ , a RECALL cycle is automatically initiated and takes  $t_{\text{HRECALL}}$  to complete.

If the CY14E256L is in a WRITE state at the end of power up RECALL, the SRAM data is corrupted. To help avoid this situation, a 10 Kohm resistor is connected either between WE and system  $V_{\text{CC}}$  or between  $\overline{\text{CE}}$  and system  $V_{\text{CC}}$ .

### Software STORE

Data is transferred from the SRAM to the nonvolatile memory by a software address sequence. The CY14E256L software STORE cycle is initiated by executing sequential  $\overline{\text{CE}}$  controlled READ cycles from six specific address locations in exact order. During the STORE cycle, an erase of the previous nonvolatile data is first performed followed by a program of the nonvolatile elements. When a STORE cycle is initiated, input and output are disabled until the cycle is completed.

Because a sequence of READs from specific addresses is used for STORE initiation, it is important that no other READ or WRITE accesses intervene in the sequence. If they intervene, the sequence is aborted and no STORE or RECALL takes place.

To initiate the software STORE cycle, the following READ sequence is performed:

1. Read address 0x0E38, Valid READ
2. Read address 0x31C7, Valid READ
3. Read address 0x03E0, Valid READ
4. Read address 0x3C1F, Valid READ
5. Read address 0x303F, Valid READ
6. Read address 0x0FC0, Initiate STORE cycle

The software sequence is clocked with  $\overline{\text{CE}}$  controlled READs. When the sixth address in the sequence is entered, the STORE cycle commences and the chip is disabled. It is important that READ cycles and not WRITE cycles are used in the sequence. It is not necessary that  $\overline{\text{OE}}$  is LOW for a valid sequence. After the  $t_{\text{STORE}}$  cycle time is fulfilled, the SRAM is again activated for READ and WRITE operation.

### Software RECALL

Data is transferred from the nonvolatile memory to the SRAM by a software address sequence. A software RECALL cycle is initiated with a sequence of READ operations in a manner similar to the software STORE initiation. To initiate the RECALL cycle, the following sequence of  $\overline{\text{CE}}$  controlled READ operations is performed:

1. Read address 0x0E38, Valid READ
2. Read address 0x31C7, Valid READ
3. Read address 0x03E0, Valid READ
4. Read address 0x3C1F, Valid READ
5. Read address 0x303F, Valid READ
6. Read address 0x0C63, Initiate RECALL cycle

Internally, RECALL is a two step procedure. First, the SRAM data is cleared, and then the nonvolatile information is transferred into the SRAM cells. After the  $t_{\text{RECALL}}$  cycle time, the SRAM is once again ready for READ and WRITE operations. The RECALL operation does not alter the data in the nonvolatile elements. The nonvolatile data can be recalled an unlimited number of times.

## Data Protection

The CY14E256L protects data from corruption during low voltage conditions by inhibiting all externally initiated STORE and WRITE operations. The low voltage condition is detected when  $V_{CC}$  is less than  $V_{SWITCH}$ . If the CY14E256L is in a WRITE mode (both CE and WE are low) at power up after a RECALL or after a STORE, the WRITE is inhibited until a negative transition on CE or WE is detected. This protects against inadvertent writes during power up or brown out conditions.

## Noise Considerations

The CY14E256L is a high speed memory. It must have a high frequency bypass capacitor of approximately 0.1  $\mu$ F connected between  $V_{CC}$  and  $V_{SS}$ , using leads and traces that are as short as possible. As with all high speed CMOS ICs, careful routing of power, ground, and signals reduce circuit noise.

## Hardware Protect

The CY14E256L offers hardware protection against inadvertent STORE operation and SRAM WRITES during low voltage conditions. When  $V_{CAP} < V_{SWITCH}$ , all externally initiated STORE operations and SRAM WRITES are inhibited. AutoStore can be completely disabled by tying  $V_{CC}$  to ground and applying + 5V to  $V_{CAP}$ . This is the AutoStore Inhibit mode; in this mode, STOREs are only initiated by explicit request using either the software sequence or the HSB pin.

## Low Average Active Power

CMOS technology provides the CY14E256L the benefit of drawing significantly less current when it is cycled at times longer than 50 ns. Figure 4 shows the relationship between  $I_{CC}$  and READ or WRITE cycle time. Worst case current consumption is shown for both CMOS and TTL input levels (commercial temperature range,  $V_{CC} = 5.5V$ , 100% duty cycle on chip enable). Only standby current is drawn when the chip is disabled. The overall average current drawn by the CY14E256L depends on the following items:

- The duty cycle of chip enable
- The overall cycle rate for accesses
- The ratio of READs to WRITEs
- CMOS versus TTL input levels
- The operating temperature
- The  $V_{CC}$  level
- I/O loading

Figure 4. Current Versus Cycle Time (READ)

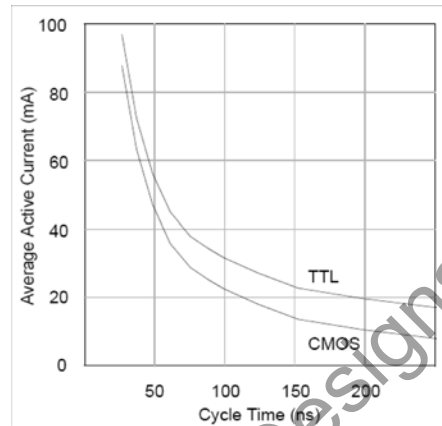
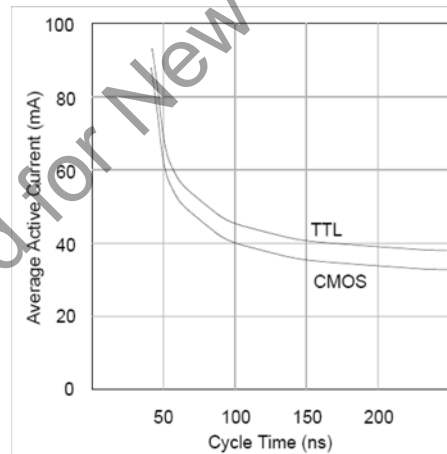

Figure 5. Current Versus Cycle Time (WRITE)



## Preventing Store

The STORE function is disabled by holding  $\overline{HSB}$  high with a driver capable of sourcing 30 mA at a  $V_{OH}$  of at least 2.2V, because it has to overpower the internal pull down device. This device drives  $\overline{HSB}$  LOW for 20  $\mu$ s at the onset of a STORE. When the CY14E256L is connected for AutoStore operation (system  $V_{CC}$  connected to  $V_{CC}$  and a 68  $\mu$ F capacitor on  $V_{CAP}$ ) and  $V_{CC}$  crosses  $V_{SWITCH}$  on the way down, the CY14E256L attempts to pull  $\overline{HSB}$  LOW. If  $\overline{HSB}$  does not actually get below  $V_{IL}$ , the part stops trying to pull  $\overline{HSB}$  LOW and abort the STORE attempt.

## Best Practices

nvSRAM products have been used effectively for over 15 years. While ease of use is one of the product's main system values, experience gained working with hundreds of applications has resulted in the following suggestions as best practices:

- The nonvolatile cells in an nvSRAM are programmed on the test floor during final test and quality assurance. Incoming inspection routines at customer or contract manufacturer's sites sometimes reprogram these values. Final NV patterns are typically repeating patterns of AA, 55, 00, FF, A5, or 5A. End product's firmware should not assume an NV array is in a set programmed state. Routines that check memory content values to determine first time system configuration, cold or warm boot status, and so on should always program a unique NV pattern (for example, complex 4-byte pattern of 46 E6 49 53 hex or more random bytes) as part of the final system

manufacturing test to ensure these system routines work consistently.

- Power up boot firmware routines should rewrite the nvSRAM into the desired state. While the nvSRAM is shipped in a preset state, best practice is to again rewrite the nvSRAM into the desired state as a safeguard against events that might flip the bit inadvertently (program bugs, incoming inspection routines, and so on).
- The  $V_{CAP}$  value specified in this data sheet includes a minimum and a maximum value size. Best practice is to meet this requirement and not exceed the maximum  $V_{CAP}$  value because the higher inrush currents may reduce the reliability of the internal pass transistor. Customers who want to use a larger  $V_{CAP}$  value to make sure there is extra store charge should discuss their  $V_{CAP}$  size selection with Cypress to understand any impact on the  $V_{CAP}$  voltage level at the end of a  $t_{RECALL}$  period.

Table 2. Hardware Mode Selection

CE	WE	HSB	A13-A0	Mode	I/O	Power
H	X	H	X	Not Selected	Output High Z	Standby
L	H	H	X	Read SRAM	Output Data	Active <sup>[1]</sup>
L	L	H	X	Write SRAM	Input Data	Active
X	X	L	X	Nonvolatile STORE	Output High Z	$I_{CC2}$ <sup>[2]</sup>
L	H	H	0x0E38 0x31C7 0x03E0 0x3C1F 0x303F 0x0FC0	Read SRAM Read SRAM Read SRAM Read SRAM Read SRAM Nonvolatile STORE	Output Data Output Data Output Data Output Data Output Data Output High Z	Active <sup>[1, 3, 4, 5]</sup> $I_{CC2}$
L	H	H	0x0E38 0x31C7 0x03E0 0x3C1F 0x303F 0x0C63	Read SRAM Read SRAM Read SRAM Read SRAM Read SRAM Nonvolatile RECALL	Output Data Output Data Output Data Output Data Output Data Output High Z	Active <sup>[1, 3, 4, 5]</sup>

### Notes

1. I/O state assumes  $\overline{OE} \leq V_{IL}$ . Activation of nonvolatile cycles does not depend on state of  $\overline{OE}$ .
2. HSB STORE operation occurs only if an SRAM WRITE has been done since the last nonvolatile cycle. After the STORE (if any) completes, the part goes into standby mode, inhibiting all operations until HSB rises.
3. CE and OE LOW and WE HIGH for output behavior.
4. The six consecutive addresses must be in the order listed. WE must be high during all six consecutive CE controlled cycles to enable a nonvolatile cycle.
5. While there are 15 addresses on the CY14E256L, only the lower 14 are used to control software modes.

### Maximum Ratings

Exceeding maximum ratings may shorten the useful life of the device. These user guidelines are not tested.

- Storage Temperature ..... -65°C to +150°C
- Ambient Temperature with Power Applied ..... -55°C to +125°C
- Supply Voltage on V<sub>CC</sub> Relative to GND ..... -0.5V to 7.0V
- Voltage Applied to Outputs in High Z State ..... -0.5V to V<sub>CC</sub> + 0.5V
- Input Voltage ..... -0.5V to V<sub>CC</sub> + 0.5V
- Transient Voltage (<20 ns) on Any Pin to Ground Potential ..... -2.0V to V<sub>CC</sub> + 2.0V

- Package Power Dissipation Capability (T<sub>A</sub> = 25°C) ..... 1.0W
- Surface Mount Lead Soldering Temperature (3 Seconds) ..... +260°C
- DC output Current (1 output at a time, 1s duration) .... 15 mA
- Static Discharge Voltage ..... > 2001V (MIL-STD-883, Method 3015)
- Latch Up Current ..... > 200 mA

### Operating Range

Range	Ambient Temperature	V <sub>CC</sub>
Commercial	0°C to +70°C	4.5V to 5.5V
Industrial	-40°C to +85°C	4.5V to 5.5V

### DC Electrical Characteristics

Over the operating range (V<sub>CC</sub> = 4.5V to 5.5V) [6]

Parameter	Description	Test Conditions	Min	Max	Unit
I <sub>CC1</sub>	Average V <sub>CC</sub> Current	t <sub>RC</sub> = 25 ns t <sub>RC</sub> = 35 ns t <sub>RC</sub> = 45 ns Dependent on output loading and cycle rate. Values obtained without output loads. I <sub>OUT</sub> = 0 mA.	Commercial	97 80 70	mA mA mA
			Industrial	100 85 70	mA mA mA
I <sub>CC2</sub>	Average V <sub>CC</sub> Current during STORE	All Inputs Do Not Care, V <sub>CC</sub> = Max Average current for duration t <sub>STORE</sub>		3	mA
I <sub>CC3</sub>	Average V <sub>CC</sub> Current at t <sub>RC</sub> = 200 ns, 5V, 25°C Typical	WE ≥ (V <sub>CC</sub> - 0.2V). All other inputs cycling. Dependent on output loading and cycle rate. Values obtained without output loads.		10	mA
I <sub>CC4</sub>	Average V <sub>CAP</sub> Current during AutoStore Cycle	All Inputs Do Not Care, V <sub>CC</sub> = Max Average current for duration t <sub>STORE</sub>		2	mA
I <sub>SB</sub> [7]	V <sub>CC</sub> Standby Current	CE ≥ (V <sub>CC</sub> - 0.2V). All others V <sub>IN</sub> ≤ 0.2V or ≥ (V <sub>CC</sub> - 0.2V). Standby current level after nonvolatile cycle is complete. Inputs are static. f = 0 MHz.		1.5	mA
I <sub>SB1</sub> [7]	V <sub>CC</sub> Standby Current (Standby, Cycling TTL Input Levels)	t <sub>RC</sub> = 25 ns, CE ≥ V <sub>IH</sub> t <sub>RC</sub> = 35 ns, CE ≥ V <sub>IH</sub> t <sub>RC</sub> = 45 ns, CE ≥ V <sub>IH</sub>	Commercial	30 25 22	mA mA mA
			Industrial	31 26 23	mA mA mA
I <sub>IX</sub>	Input Leakage Current	V <sub>CC</sub> = Max, V <sub>SS</sub> ≤ V <sub>IN</sub> ≤ V <sub>CC</sub>	-1	+1	µA
I <sub>OZ</sub>	Off State Output Leakage Current	V <sub>CC</sub> = Max, V <sub>SS</sub> ≤ V <sub>IN</sub> ≤ V <sub>CC</sub> , CE or OE ≥ V <sub>IH</sub> or WE ≤ V <sub>IL</sub>	-5	+5	µA
V <sub>IH</sub>	Input HIGH Voltage		2.2	V <sub>CC</sub> + 0.5	V
V <sub>IL</sub>	Input LOW Voltage		V <sub>SS</sub> - 0.5	0.8	V

**Notes**

- 6. V<sub>CC</sub> reference levels throughout this data sheet refer to V<sub>CC</sub> if that is where the power supply connection is made, or V<sub>CAP</sub> if V<sub>CC</sub> is connected to ground.
- 7. CE ≥ V<sub>IH</sub> does not produce standby current levels until any nonvolatile cycle in progress has timed out.

### DC Electrical Characteristics

Over the operating range (continued)(V<sub>CC</sub> = 4.5V to 5.5V) [6]

Parameter	Description	Test Conditions	Min	Max	Unit
V <sub>OH</sub>	Output HIGH Voltage	I <sub>OUT</sub> = -4 mA	2.4		V
V <sub>OL</sub>	Output LOW Voltage	I <sub>OUT</sub> = 8 mA		0.4	V
V <sub>BL</sub>	Logic '0' Voltage on HSB Output	I <sub>OUT</sub> = 3 mA		0.4	V
V <sub>CAP</sub>	Storage Capacitor	Between V <sub>CAP</sub> pin and V <sub>SS</sub> , 6V rated. 68 μF ±20% nom.	54	260	μF

### Data Retention and Endurance

Parameter	Description	Min	Unit
DATA <sub>R</sub>	Data Retention	100	Years
NV <sub>C</sub>	Nonvolatile STORE Operations	1,000	K

### Capacitance

In the following table, the capacitance parameters are listed.[8]

Parameter	Description	Test Conditions	Max	Unit
C <sub>IN</sub>	Input Capacitance	T <sub>A</sub> = 25°C, f = 1 MHz,	5	pF
C <sub>OUT</sub>	Output Capacitance	V <sub>CC</sub> = 0 to 3.0V	7	pF

### Thermal Resistance

In the following table, the thermal resistance parameters are listed.[8]

Parameter	Description	Test Conditions	32-SOIC	32-CDIP	Unit
Θ <sub>JA</sub>	Thermal Resistance (Junction to Ambient)	Test conditions follow standard test methods and procedures for measuring thermal impedance, per EIA / JESD51.	35.45	TBD	°C/W
Θ <sub>JC</sub>	Thermal Resistance (Junction to Case)		13.26	TBD	°C/W

Figure 6. AC Test Loads

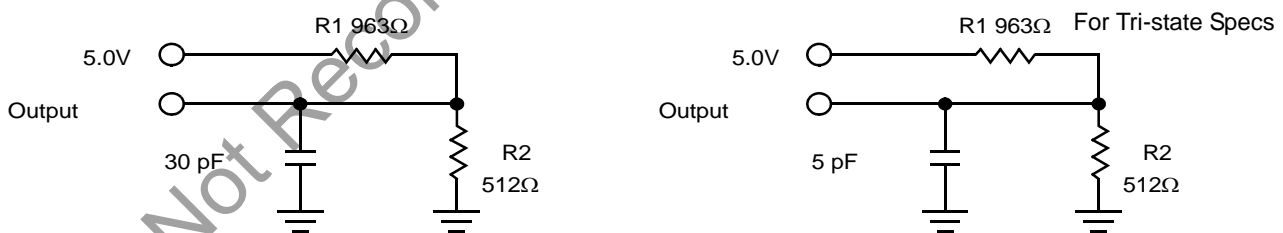

### AC Test Conditions

Input Pulse Levels ..... 0V to 3V  
 Input Rise and Fall Times (10% - 90%) ..... ≤5 ns  
 Input and Output Timing Reference Levels ..... 1.5V

**Note**

8. These parameters are guaranteed by design and are not tested.

## AC Switching Characteristics

### SRAM Read Cycle

Parameter		Description	25 ns		35 ns		45 ns		Unit
Cypress Parameter	Alt		Min	Max	Min	Max	Min	Max	
$t_{ACE}$	$t_{ELQV}$	Chip Enable Access Time		25		35		45	ns
$t_{RC}^{[9]}$	$t_{AVAV}, t_{ELEH}$	Read Cycle Time	25		35		45		ns
$t_{AA}^{[10]}$	$t_{AVQV}$	Address Access Time		25		35		45	ns
$t_{DOE}$	$t_{GLQV}$	Output Enable to Data Valid		10		15		20	ns
$t_{OHA}^{[10]}$	$t_{AXQX}$	Output Hold After Address Change	5		5		5		ns
$t_{LZCE}^{[11]}$	$t_{ELQX}$	Chip Enable to Output Active	5		5		5		ns
$t_{HZCE}^{[11]}$	$t_{EHQZ}$	Chip Disable to Output Inactive		10		13		15	ns
$t_{LZOE}^{[11]}$	$t_{GLQX}$	Output Enable to Output Active	0		0		0		ns
$t_{HZOE}^{[11]}$	$t_{GHQZ}$	Output Disable to Output Inactive		10		13		15	ns
$t_{PU}^{[8]}$	$t_{ELICCH}$	Chip Enable to Power Active	0		0		0		ns
$t_{PD}^{[8]}$	$t_{EHICCL}$	Chip Disable to Power Standby		25		35		45	ns

### Switching Waveforms

Figure 7. SRAM Read Cycle 1: Address Controlled <sup>[9, 10]</sup>

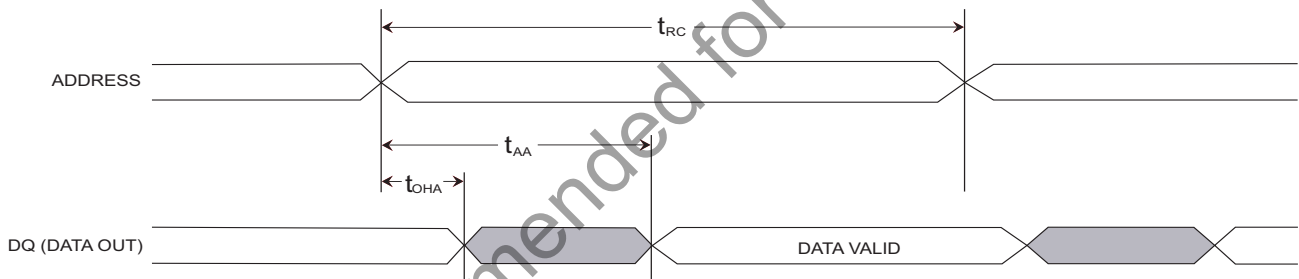
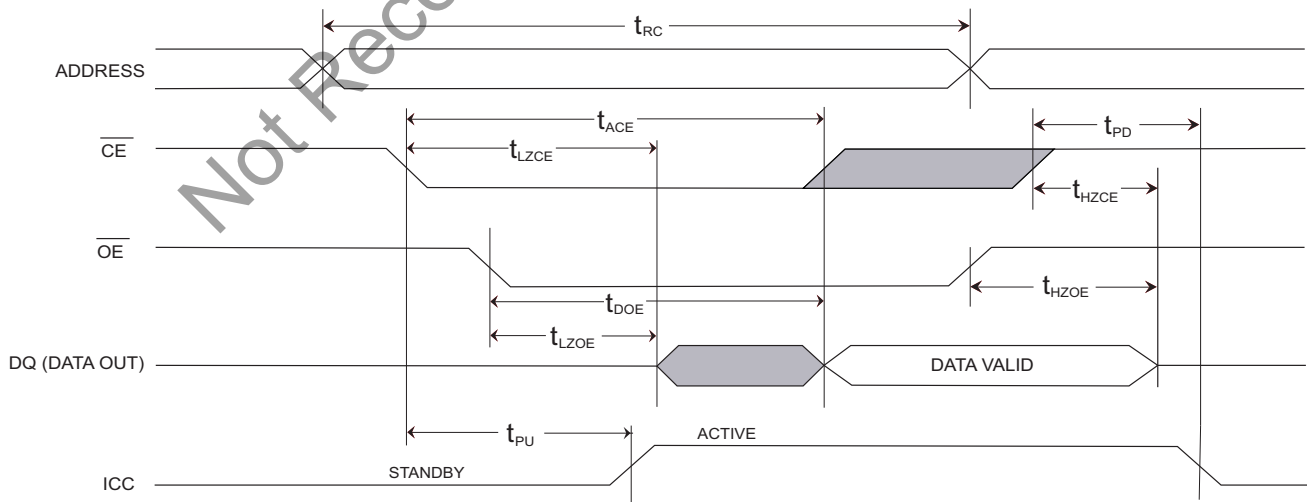

Figure 8. SRAM Read Cycle 2:  $\overline{CE}$  and  $\overline{OE}$  Controlled <sup>[9]</sup>



#### Notes

9. WE and HSB must be HIGH during SRAM Read cycles.
10. Device is continuously selected with CE and OE both Low.
11. Measured  $\pm 200$  mV from steady state output voltage.

SRAM Write Cycle

Parameter		Description	25 ns		35 ns		45 ns		Unit
Cypress Parameter	Alt		Min	Max	Min	Max	Min	Max	
$t_{WC}$	$t_{AVAV}$	Write Cycle Time	25		35		45		ns
$t_{PWE}$	$t_{WLWH}, t_{WLEH}$	Write Pulse Width	20		25		30		ns
$t_{SCE}$	$t_{ELWH}, t_{ELEH}$	Chip Enable To End of Write	20		25		30		ns
$t_{SD}$	$t_{DVWH}, t_{DVEH}$	Data Setup to End of Write	10		12		15		ns
$t_{HD}$	$t_{WHDX}, t_{EHDX}$	Data Hold After End of Write	0		0		0		ns
$t_{AW}$	$t_{AVWH}, t_{AVEH}$	Address Setup to End of Write	20		25		30		ns
$t_{SA}$	$t_{AVWL}, t_{AVEL}$	Address Setup to Start of Write	0		0		0		ns
$t_{HA}$	$t_{WHAX}, t_{EHAX}$	Address Hold After End of Write	0		0		0		ns
$t_{HZWE}^{[11,12]}$	$t_{WLQZ}$	Write Enable to Output Disable		10		13		15	ns
$t_{LZWE}^{[11]}$	$t_{WHQX}$	Output Active After End of Write	5		5		5		ns

Switching Waveforms

Figure 9. SRAM Write Cycle 1:  $\overline{WE}$  Controlled [13, 14]

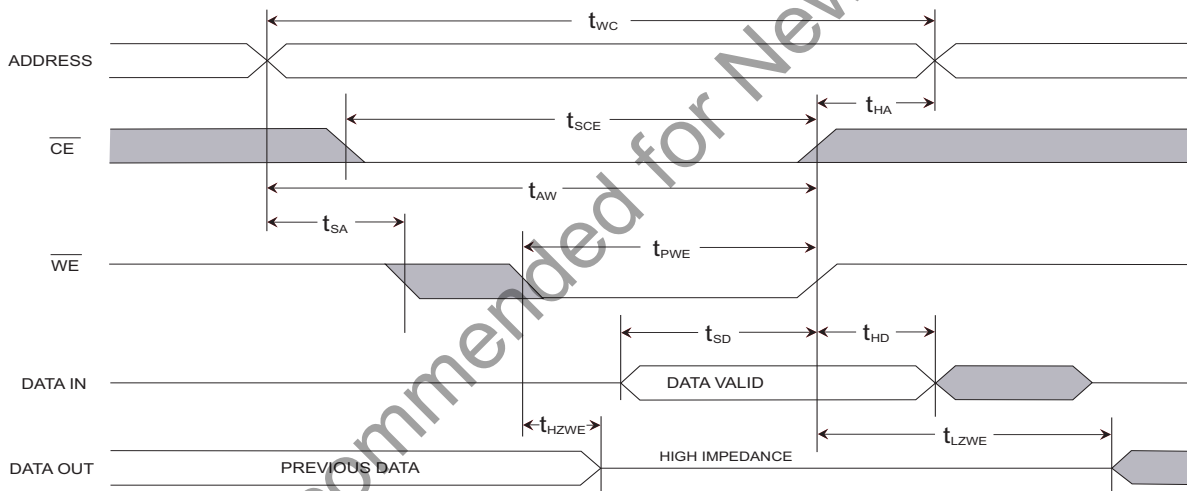
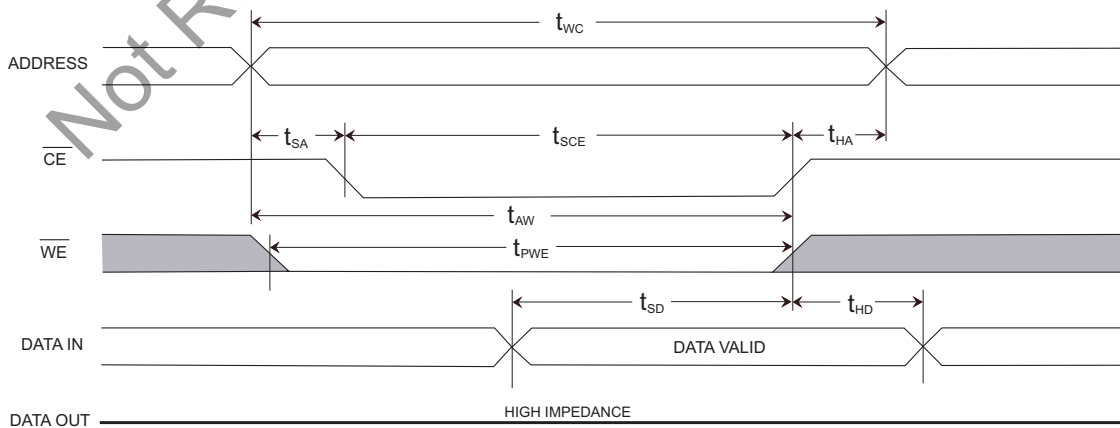

Figure 10. SRAM Write Cycle 2:  $\overline{CE}$  Controlled [13, 14]



Notes

- 12. If  $\overline{WE}$  is Low when  $\overline{CE}$  goes Low, the outputs remain in the high impedance state.
- 13. HSB must be high during SRAM WRITE cycles.
- 14.  $\overline{CE}$  or  $\overline{WE}$  must be greater than  $V_{IH}$  during address transitions.

### AutoStore or Power Up RECALL

Parameter	Alt	Description	CY14E256L		Unit
			Min	Max	
$t_{HRECALL}^{[15]}$	$t_{RESTORE}$	Power up RECALL Duration		550	$\mu s$
$t_{STORE}^{[16]}$	$t_{HLHZ}$	STORE Cycle Duration		10	ms
$t_{DELAY}^{[16]}$	$t_{HLQZ}, t_{BLQZ}$	Time Allowed to Complete SRAM Cycle	1		$\mu s$
$V_{SWITCH}$		Low Voltage Trigger Level	4.0	4.5	V
$V_{RESET}$		Low Voltage Reset Level		3.6	V
$t_{VCCRISE}$		$V_{CC}$ Rise Time	150		$\mu s$
$t_{VSBL}^{[13]}$		Low Voltage Trigger ( $V_{SWITCH}$ ) to HSB low		300	ns

### Switching Waveforms

Figure 11. AutoStore/Power Up RECALL

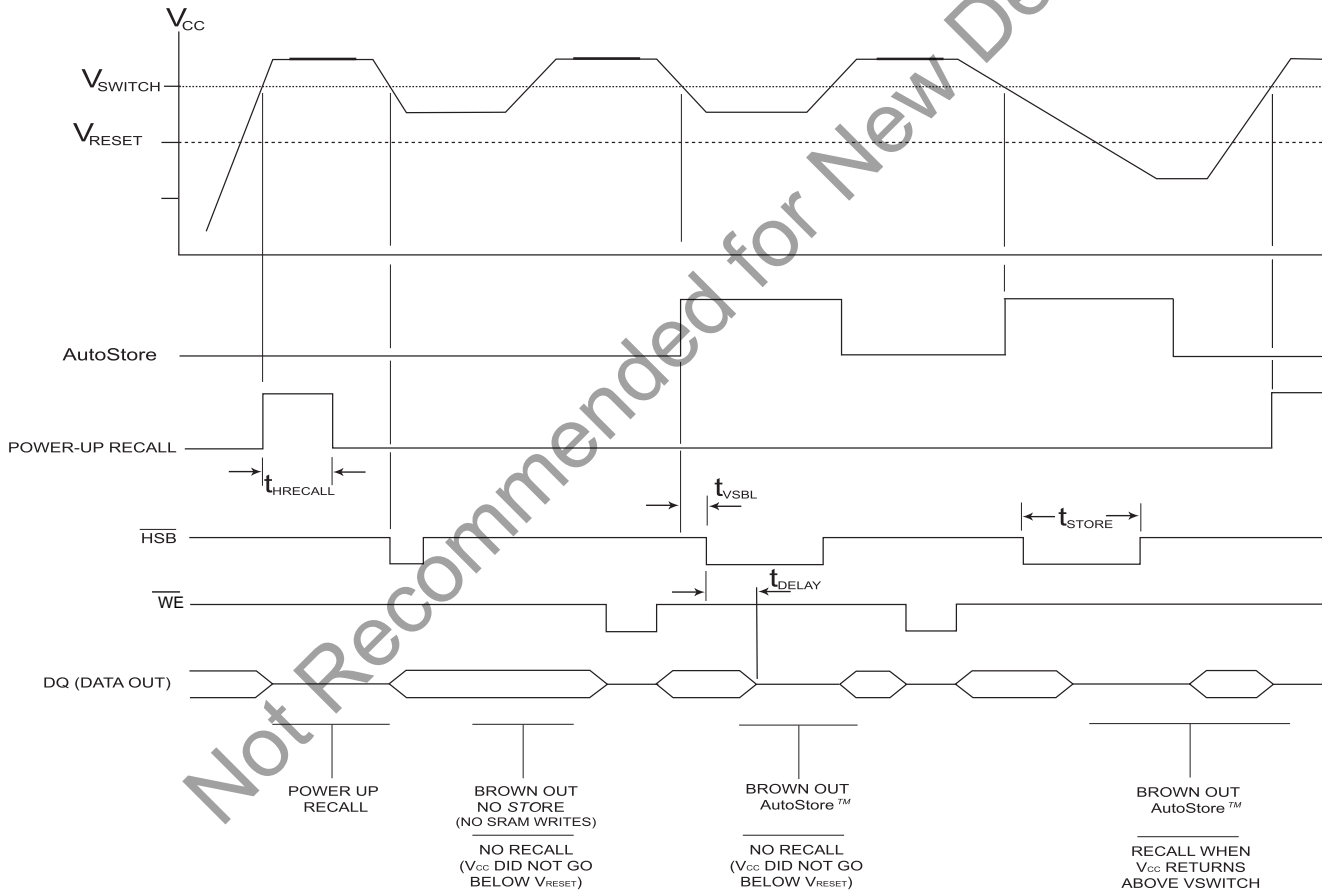

**Notes**

15.  $t_{HRECALL}$  starts from the time  $V_{CC}$  rises above  $V_{SWITCH}$ .

16. CE and OE low and WE high for output behavior.

17. HSB is asserted low for 1us when  $V_{CAP}$  drops through  $V_{SWITCH}$ . If an SRAM WRITE has not taken place since the last nonvolatile cycle,  $\overline{HSB}$  is released and no store takes place.

### Software Controlled STORE/RECALL Cycle

The software controlled STORE/RECALL cycle follows. <sup>[19]</sup>

Parameter	Alt	Description	25 ns		35 ns		45 ns		Unit
			Min	Max	Min	Max	Min	Max	
$t_{RC}^{[16]}$	$t_{AVAV}$	STORE/RECALL Initiation Cycle Time	25		35		45		ns
$t_{SA}^{[18, 19]}$	$t_{AVEL}$	Address Setup Time	0		0		0		ns
$t_{CW}^{[18, 19]}$	$t_{ELEH}$	Clock Pulse Width	20		25		30		ns
$t_{HACE}^{[18, 19]}$	$t_{ELAX}$	Address Hold Time	20		20		20		ns
$t_{RECALL}$		RECALL Duration		20		20		20	$\mu$ s

### Switching Waveforms

Figure 12.  $\overline{CE}$  Controlled Software STORE/RECALL Cycle <sup>[19]</sup>

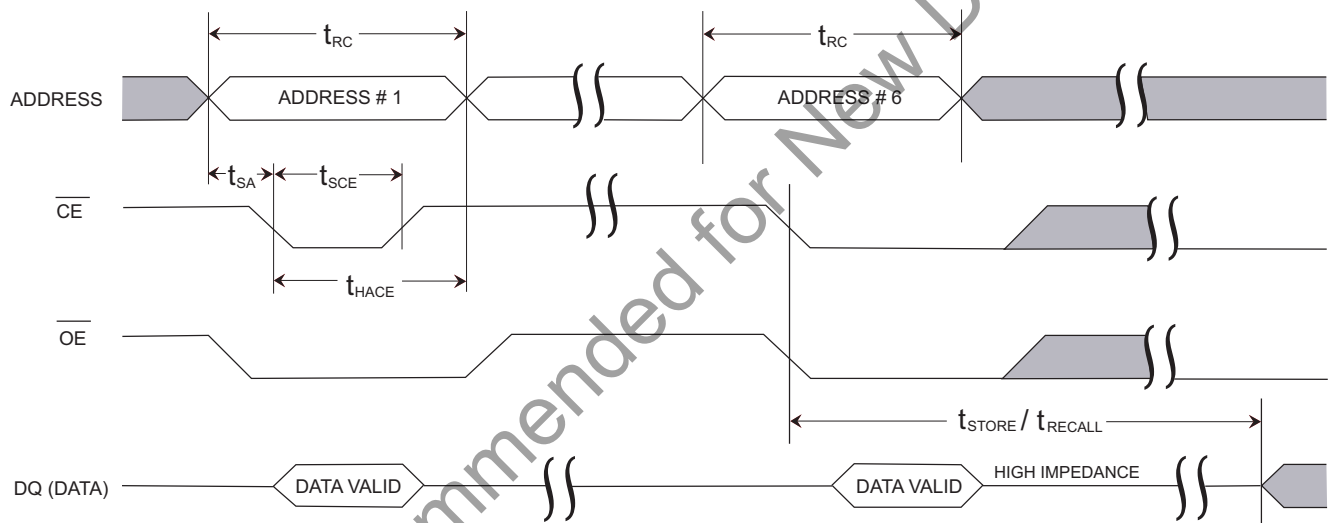

**Notes**

- 18. The software sequence is clocked on the falling edge of  $\overline{CE}$  without involving  $\overline{OE}$  (double clocking aborts the sequence).
- 19. The six consecutive addresses must be read in the order listed in the Mode Selection table.  $\overline{WE}$  must be HIGH during all six consecutive cycles.

### Hardware STORE Cycle

Parameter	Alt	Description	CY14E256L		Unit
			Min	Max	
$t_{DHSB}^{[16, 20]}$	$t_{RECOVER}, t_{HHQX}$	Hardware STORE High to Inhibit Off		700	ns
$t_{PHSB}$	$t_{HLHX}$	Hardware STORE Pulse Width	15		ns
$t_{HLBL}$		Hardware STORE Low to STORE Busy		300	ns

### Switching Waveforms

Figure 13. Hardware STORE Cycle

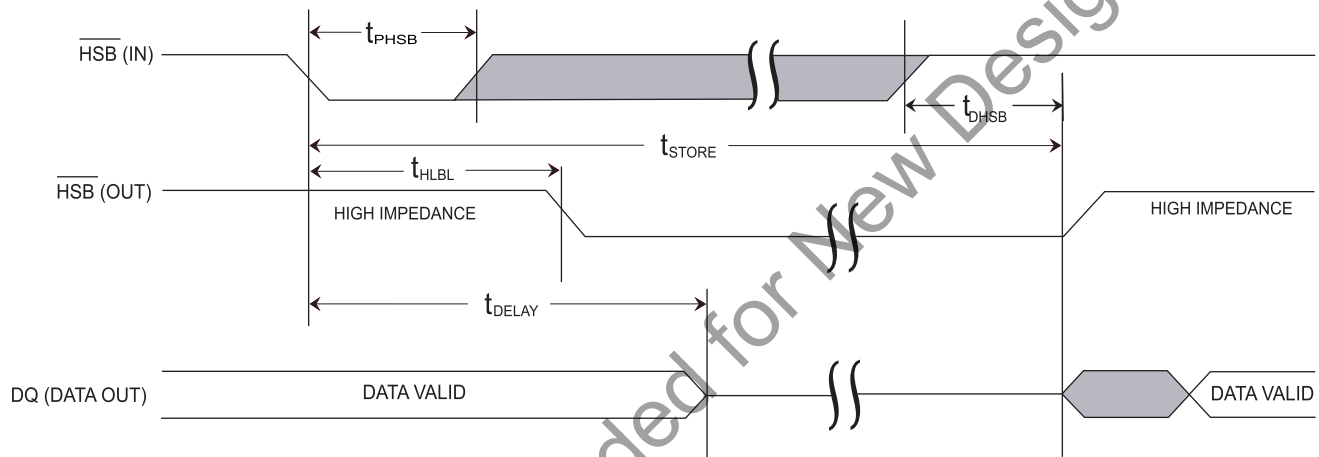

**Note**  
 20.  $t_{DHSB}$  is only applicable after  $t_{STORE}$  is complete.

**Part Numbering Nomenclature (Commercial and Industrial)**

**CY 14 E 256 L- SZ 25 X C T**

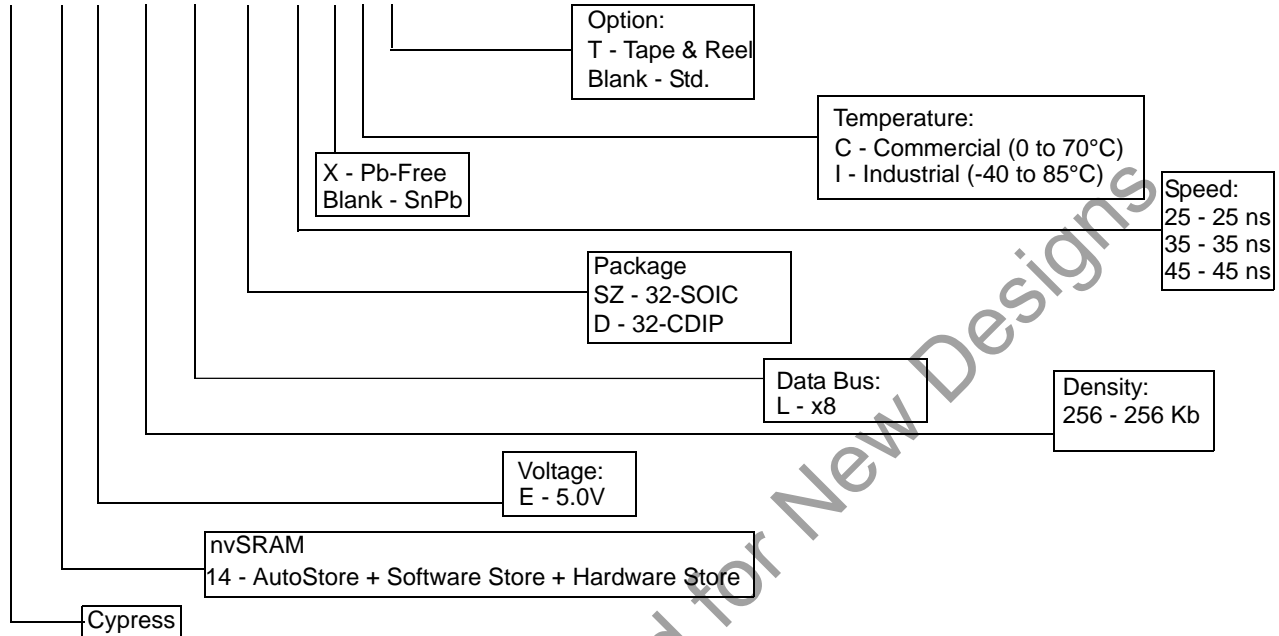

**Ordering Information**

These parts are not recommended for new designs.

Speed (ns)	Ordering Code	Package Diagram	Package Type	Operating Range
25	CY14E256L-SZ25XCT	51-85127	32-pin SOIC (300 mil)	Commercial
	CY14E256L-SZ25XC	51-85127	32-pin SOIC (300 mil)	
	CY14E256L-SZ25XIT	51-85127	32-pin SOIC (300 mil)	Industrial
	CY14E256L-SZ25XI	51-85127	32-pin SOIC (300 mil)	
35	CY14E256L-SZ35XCT	51-85127	32-pin SOIC (300 mil)	Commercial
	CY14E256L-SZ35XC	51-85127	32-pin SOIC (300 mil)	
	CY14E256L-SZ35XIT	51-85127	32-pin SOIC (300 mil)	Industrial
	CY14E256L-SZ35XI	51-85127	32-pin SOIC (300 mil)	
45	CY14E256L-SZ45XCT	51-85127	32-pin SOIC (300 mil)	Commercial
	CY14E256L-SZ45XC	51-85127	32-pin SOIC (300 mil)	
	CY14E256L-SZ45XIT	51-85127	32-pin SOIC (300 mil)	Industrial
	CY14E256L-SZ45XI	51-85127	32-pin SOIC (300 mil)	
	CY14E256L-D45I	001-51694	32-pin CDIP (300 mil)	

This table contains Final information. Contact your local Cypress sales representative for availability of these parts

Package Diagram

Figure 14. 32-Pin (300 Mil) SOIC (51-85127)



51-85127-\*A

Package Diagram (continued)

Figure 15. 32-Pin (300 Mil) CDIP (001-51694)

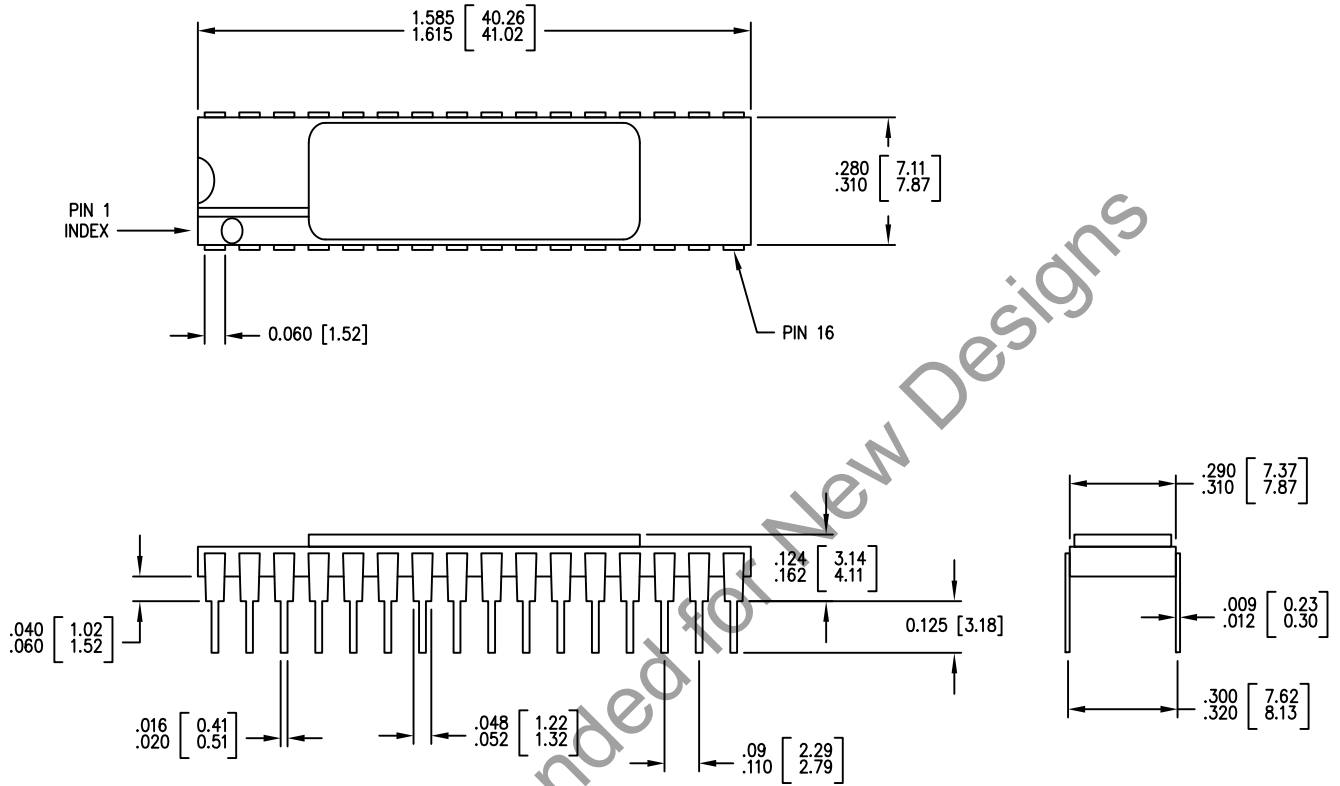

1. ALL DIMENSIONS ARE IN MILLIMETERS AND INCHS [MIN/MAX]
2. PACKAGE WEIGHT : TBD

001-51694 \*\*

Document History Page

Document Title: CY14E256L 256 Kbit (32K x 8) nvSRAM Document Number: 001-06968				
Rev.	ECN No.	Submission Date	Orig. of Change	Description of Change
**	427789	See ECN	TUP	New data sheet
*A	437321	See ECN	TUP	Show data sheet on external Web
*B	472053	See ECN	TUP	Updated Part Numbering Nomenclature and Ordering Information
*C	503290	See ECN	PCI	Changed from "Advance" to "Preliminary" Changed the term "Unlimited" to "Infinite" Changed I <sub>CC3</sub> value from 10mA to 15mA Removed Industrial Grade mention Removed 35 ns speed bin Removed I <sub>CC1</sub> values from the DC table for 35 ns Industrial Grade Corrected V <sub>IL</sub> min specification from (V <sub>CC</sub> - 0.5) to (V <sub>SS</sub> - 0.5) Removed all references pertaining to OE controlled Software STORE and RECALL operation Changed the address locations of the software STORE/RECALL command Updated Part Nomenclature Table and Ordering Information Table
*D	1349963	See ECN	UHA/SFV	Changed from "Preliminary" to "Final." Updated AC Test Conditions Updated Ordering Information Table
*E	2427986	See ECN	GVCH	Move to external web
*F	2606744	02/19/09	GVCH/PYRS	Updated Feature Section Added 35 ns access speed specs Added CDIP package Removed HSB ganging feature Added footnote 5 Updates all the notes Added Best practices Added Industrial specs Changed I <sub>CC3</sub> from 15 mA to 10 mA Added I <sub>SB1</sub> spec Added parameter V <sub>BL</sub> Changed V <sub>IH</sub> test conditions from -2 and 4 to -4 and 8mA Added footnote 6 and 7 Added t <sub>VSBL</sub> and V <sub>RESET</sub> parameter to Autostore or Power-up Recall table Added Thermal resistance values Changed parameter t <sub>AS</sub> to t <sub>SA</sub> Renamed t <sub>GLAX</sub> to t <sub>HACE</sub> Renamed t <sub>RESTORE</sub> to t <sub>DHSB</sub> Updated Figure 13
*G	2708327	05/18/2009	GVCH/PYRS	Changed part number from CY14E256L-D45XI to CY14E256L-D45I
*H	2815609	11/26/2009	GVCH	Added note in the <a href="#">Ordering Information</a> table and watermark to state that the parts in this data sheet are not recommended for new designs. Added the <a href="#">Contents</a> page.

## Sales, Solutions, and Legal Information

### Worldwide Sales and Design Support

Cypress maintains a worldwide network of offices, solution centers, manufacturer's representatives, and distributors. To find the office closest to you, visit us at [cypress.com/sales](http://cypress.com/sales)

### Products

PSoC	<a href="http://psoc.cypress.com">psoc.cypress.com</a>
Clocks & Buffers	<a href="http://clocks.cypress.com">clocks.cypress.com</a>
Wireless	<a href="http://wireless.cypress.com">wireless.cypress.com</a>
Memories	<a href="http://memory.cypress.com">memory.cypress.com</a>
Image Sensors	<a href="http://image.cypress.com">image.cypress.com</a>

© Cypress Semiconductor Corporation, 2006-2009. The information contained herein is subject to change without notice. Cypress Semiconductor Corporation assumes no responsibility for the use of any circuitry other than circuitry embodied in a Cypress product. Nor does it convey or imply any license under patent or other rights. Cypress products are not warranted nor intended to be used for medical, life support, life saving, critical control or safety applications, unless pursuant to an express written agreement with Cypress. Furthermore, Cypress does not authorize its products for use as critical components in life-support systems where a malfunction or failure may reasonably be expected to result in significant injury to the user. The inclusion of Cypress products in life-support systems application implies that the manufacturer assumes all risk of such use and in doing so indemnifies Cypress against all charges.



Any Source Code (software and/or firmware) is owned by Cypress Semiconductor Corporation (Cypress) and is protected by and subject to worldwide patent protection (United States and foreign), United States copyright laws and international treaty provisions. Cypress hereby grants to licensee a personal, non-exclusive, non-transferable license to copy, use, modify, create derivative works of, and compile the Cypress Source Code and derivative works for the sole purpose of creating custom software and or firmware in support of licensee product to be used only in conjunction with a Cypress integrated circuit as specified in the applicable agreement. Any reproduction, modification, translation, compilation, or representation of this Source Code except as specified above is prohibited without the express written permission of Cypress.

Disclaimer: CYPRESS MAKES NO WARRANTY OF ANY KIND, EXPRESS OR IMPLIED, WITH REGARD TO THIS MATERIAL, INCLUDING, BUT NOT LIMITED TO, THE IMPLIED WARRANTIES OF MERCHANTABILITY AND FITNESS FOR A PARTICULAR PURPOSE. Cypress reserves the right to make changes without further notice to the materials described herein. Cypress does not assume any liability arising out of the application or use of any product or circuit described herein. Cypress does not authorize its products for use as critical components in life-support systems where a malfunction or failure may reasonably be expected to result in significant injury to the user. The inclusion of Cypress' product in a life-support systems application implies that the manufacturer assumes all risk of such use and in doing so indemnifies Cypress against all charges.

Use may be limited by and subject to the applicable Cypress software license agreement.

## Looking for pricing, stock, or lifecycle information?

Click below to explore more details on WIN SOURCE:

-  [View CY14E256L-SZ45XC on WIN SOURCE](#)
-  [Cypress Semiconductor Corp Information](#)

## Optimize Your Supply Chain with WIN SOURCE Solutions

-  Global Sourcing Solution
-  Obsolete Management
-  Cost Control Management
-  Shortage Management
-  Alternative Solution
-  Excess Inventory Management