



**THE DATASHEET OF  
MC100EL59DW**



# MC100EL59

## 5V ECL Triple 2:1 Multiplexer

### Description

The MC100EL59 is a triple 2:1 multiplexer with differential outputs. The output data of the multiplexers can be controlled individually via the select inputs or as a group via the common select input. The flexible selection scheme makes the device useful for both data path and random logic applications.

The 100 Series Contains Temperature Compensation

### Features

- Individual or Common Select Controls
  - 500 ps Typical Propagation Delays
  - PECL Mode Operating Range:  $V_{CC} = 4.2\text{ V}$  to  $5.7\text{ V}$  with  $V_{EE} = 0\text{ V}$
  - NECL Mode Operating Range:  $V_{CC} = 0\text{ V}$  with  $V_{EE} = -4.2\text{ V}$  to  $-5.7\text{ V}$
  - Q Output will Default LOW with Inputs Open or at  $V_{EE}$
  - Internal Input Pulldown Resistors
  - ESD Protection: Human Body Model;  $> 2\text{ kV}$
  - Meets or Exceeds JEDEC Spec EIA/JESD78 IC Latchup Test
  - Moisture Sensitivity Level:
    - Pb = 1
    - Pb-Free = 3
- For Additional Information, see Application Note AND8003/D
- Flammability Rating: UL 94 V-0 @ 1.125 in, Oxygen Index: 28 to 34
  - Transistor Count = 182 devices
  - Pb-Free Package is Available\*



ON Semiconductor®

<http://onsemi.com>

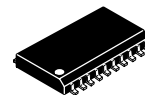

SO-20  
WB SUFFIX  
CASE 751D

### MARKING DIAGRAM\*

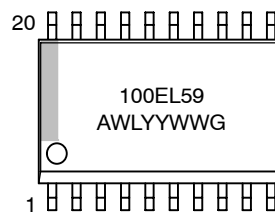

A = Assembly Location  
WL = Wafer Lot  
YY = Year  
WW = Work Week  
G = Pb-Free Package

\*For additional marking information, refer to Application Note AND8002/D.

### ORDERING INFORMATION

See detailed ordering and shipping information in the package dimensions section on page 4 of this data sheet.

\*For additional information on our Pb-Free strategy and soldering details, please download the ON Semiconductor Soldering and Mounting Techniques Reference Manual, SOLDERRM/D.

# MC100EL59

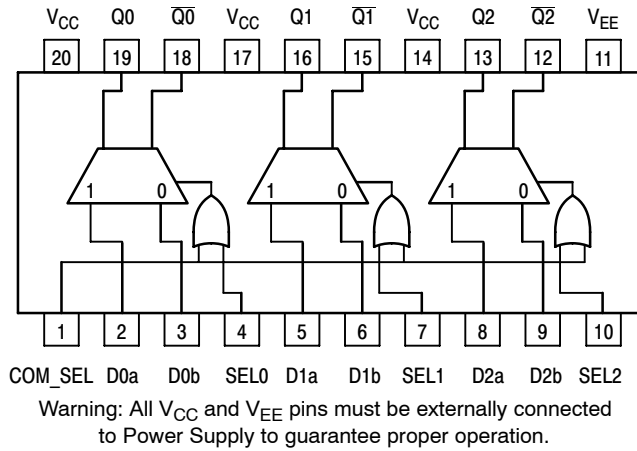

**Figure 1. Logic Diagram and Pinout: 20-Lead SOIC (Top View)**

**Table 1. PIN DESCRIPTION**

PIN	FUNCTION
D0a–D2a	ECL Input Data a*
D0b–D2b	ECL Input Data b*
SEL0–SEL2	ECL Individual Select Input*
COM_SEL	ECL Common Select Input*
Q0–Q2; Q0–Q2	ECL Differential Outputs
$V_{CC}$	Positive Supply
$V_{EE}$	Negative Supply

\*Pins will default LOW when left open.

**Table 2. TRUTH TABLE**

SEL*	DATA
H	a
L	b

\*Pins will default LOW when left open.

**Table 3. MAXIMUM RATINGS**

Symbol	Parameter	Condition 1	Condition 2	Rating	Unit
$V_{CC}$	PECL Mode Power Supply	$V_{EE} = 0\text{ V}$		8 to 0	V
$V_{EE}$	NECL Mode Power Supply	$V_{CC} = 0\text{ V}$		–8 to 0	V
$V_I$	PECL Mode Input Voltage NECL Mode Input Voltage	$V_{EE} = 0\text{ V}$ $V_{CC} = 0\text{ V}$	$V_I \leq V_{CC}$ $V_I \geq V_{EE}$	6 to 0 –6 to 0	V V
$I_{out}$	Output Current	Continuous Surge		50 100	mA mA
$T_A$	Operating Temperature Range			–40 to +85	°C
$T_{stg}$	Storage Temperature Range			–65 to +150	°C
$\theta_{JA}$	Thermal Resistance (Junction–to–Ambient)	0 lfpm 500 lfpm	SOIC–20 SOIC–20	90 60	°C/W °C/W
$\theta_{JC}$	Thermal Resistance (Junction–to–Case)	Standard Board	SOIC–20	30 to 35	°C/W
$T_{sol}$	Wave Solder	Pb Pb–Free		265 265	°C

Stresses exceeding Maximum Ratings may damage the device. Maximum Ratings are stress ratings only. Functional operation above the Recommended Operating Conditions is not implied. Extended exposure to stresses above the Recommended Operating Conditions may affect device reliability.

# MC100EL59

**Table 4. PECL DC CHARACTERISTICS**  $V_{CC} = 5.0\text{ V}$ ;  $V_{EE} = 0.0\text{ V}$  (Note 1)

Symbol	Characteristic	-40°C			25°C			85°C			Unit
		Min	Typ	Max	Min	Typ	Max	Min	Typ	Max	
$I_{EE}$	Power Supply Current		130	156		130	156		130	156	mA
$I_{EE}$	Power Supply Current		27	32		27	32		27	32	mA
$V_{OH}$	Output HIGH Voltage (Note 2)	3915	3995	4120	3975	4045	4120	3975	4050	4120	mV
$V_{OL}$	Output LOW Voltage (Note 2)	3170	3305	3445	3190	3295	3380	3190	3295	3380	mV
$V_{IH}$	Input HIGH Voltage	3835		4120	3835		4120	3835		4120	mV
$V_{IL}$	Input LOW Voltage	3190		3525	3190		3525	3190		3525	mV
$I_{IH}$	Input HIGH Current			150			150			150	$\mu\text{A}$
$I_{IL}$	Input LOW Current	0.5			0.5			0.5			$\mu\text{A}$

NOTE: Device will meet the specifications after thermal equilibrium has been established when mounted in a test socket or printed circuit board with maintained transverse airflow greater than 500 lfm. Electrical parameters are guaranteed only over the declared operating temperature range. Functional operation of the device exceeding these conditions is not implied. Device specification limit values are applied individually under normal operating conditions and not valid simultaneously.

1. Input and output parameters vary 1:1 with  $V_{CC}$ .  $V_{EE}$  can vary +0.8 V / -0.5 V.
2. Outputs are terminated through a 50  $\Omega$  resistor to  $V_{CC} - 2.0\text{ V}$ .

**Table 5. NECL DC CHARACTERISTICS**  $V_{CC} = 0.0\text{ V}$ ;  $V_{EE} = -5.0\text{ V}$  (Note 3)

Symbol	Characteristic	-40°C			25°C			85°C			Unit
		Min	Typ	Max	Min	Typ	Max	Min	Typ	Max	
$I_{EE}$	Power Supply Current		27	32		27	32		27	32	mA
$V_{OH}$	Output HIGH Voltage (Note 4)	-1085	-1005	-880	-1025	-955	-880	-1025	-955	-880	mV
$V_{OL}$	Output LOW Voltage (Note 4)	-1830	-1695	-1555	-1810	-1705	-1620	-1810	-1705	-1620	mV
$V_{IH}$	Input HIGH Voltage	-1165		-880	-1165		-880	-1165		-880	mV
$V_{IL}$	Input LOW Voltage	-1810		-1475	-1810		-1475	-1810		-1475	mV
$I_{IH}$	Input HIGH Current			150			150			150	$\mu\text{A}$
$I_{IL}$	Input LOW Current	0.5			0.5			0.5			$\mu\text{A}$

NOTE: Device will meet the specifications after thermal equilibrium has been established when mounted in a test socket or printed circuit board with maintained transverse airflow greater than 500 lfm. Electrical parameters are guaranteed only over the declared operating temperature range. Functional operation of the device exceeding these conditions is not implied. Device specification limit values are applied individually under normal operating conditions and not valid simultaneously.

3. Input and output parameters vary 1:1 with  $V_{CC}$ .  $V_{EE}$  can vary +0.8 V / -0.5 V.
4. Outputs are terminated through a 50  $\Omega$  resistor to  $V_{CC} - 2.0\text{ V}$ .

**Table 6. AC CHARACTERISTICS**  $V_{CC} = 5.0\text{ V}$ ;  $V_{EE} = 0.0\text{ V}$  or  $V_{CC} = 0.0\text{ V}$ ;  $V_{EE} = -5.0\text{ V}$  (Note 5)

Symbol	Characteristic	-40°C			25°C			85°C			Unit
		Min	Typ	Max	Min	Typ	Max	Min	Typ	Max	
$t_{PLH}$ $t_{PHL}$	Propagation Delay DATA to Q/ $\bar{Q}$ SEL to Q/ $\bar{Q}$ COM_SEL to Q/ $\bar{Q}$	340 340 340		690 690 690	340 340 340		690 690 690	340 340 340		690 690 690	ps
$t_{skew}$	Output-Output Skew Any $D_n$ , $D_m$ to Q			100			100			100	ps
$t_{JITTER}$	Cycle-to-Cycle Jitter		TBD			TBD			TBD		ps
$t_r$ $t_f$	Output Rise/Fall Times Q (20% - 80%)	200		540	200		540	200		540	ps

NOTE: Device will meet the specifications after thermal equilibrium has been established when mounted in a test socket or printed circuit board with maintained transverse airflow greater than 500 lfm. Electrical parameters are guaranteed only over the declared operating temperature range. Functional operation of the device exceeding these conditions is not implied. Device specification limit values are applied individually under normal operating conditions and not valid simultaneously.

5.  $V_{EE}$  can vary +0.8 V / -0.5 V.

## MC100EL59

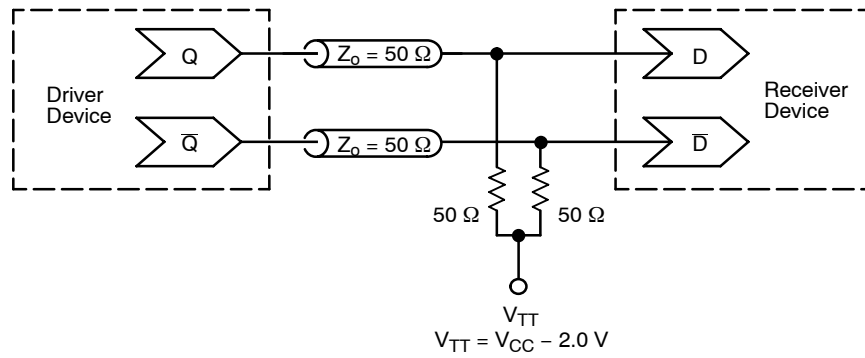

**Figure 2. Typical Termination for Output Driver and Device Evaluation  
(See Application Note AND8020/D – Termination of ECL Logic Devices.)**

### ORDERING INFORMATION

Device	Package	Shipping <sup>†</sup>
MC100EL59DW	SOIC-20	38 Units / Rail
MC100EL59DWG	SOIC-20 (Pb-Free)	38 Units / Rail

<sup>†</sup>For information on tape and reel specifications, including part orientation and tape sizes, please refer to our Tape and Reel Packaging Specifications Brochure, BRD8011/D.

#### Resource Reference of Application Notes

- AN1405/D** – ECL Clock Distribution Techniques
- AN1406/D** – Designing with PECL (ECL at +5.0 V)
- AN1503/D** – ECLinPS™ I/O SPICE Modeling Kit
- AN1504/D** – Metastability and the ECLinPS Family
- AN1568/D** – Interfacing Between LVDS and ECL
- AN1672/D** – The ECL Translator Guide
- AND8001/D** – Odd Number Counters Design
- AND8002/D** – Marking and Date Codes
- AND8020/D** – Termination of ECL Logic Devices
- AND8066/D** – Interfacing with ECLinPS
- AND8090/D** – AC Characteristics of ECL Devices

# MC100EL59

## PACKAGE DIMENSIONS

SO-20 WB  
CASE 751D-05  
ISSUE G

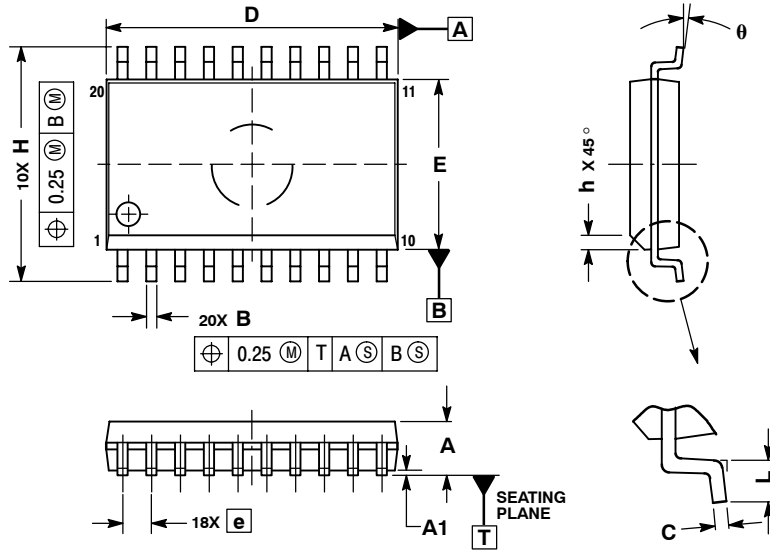

### NOTES:

1. DIMENSIONS ARE IN MILLIMETERS.
2. INTERPRET DIMENSIONS AND TOLERANCES PER ASME Y14.5M, 1994.
3. DIMENSIONS D AND E DO NOT INCLUDE MOLD PROTRUSION.
4. MAXIMUM MOLD PROTRUSION 0.15 PER SIDE.
5. DIMENSION B DOES NOT INCLUDE DAMBAR PROTRUSION. ALLOWABLE PROTRUSION SHALL BE 0.13 TOTAL IN EXCESS OF B DIMENSION AT MAXIMUM MATERIAL CONDITION.

MILLIMETERS		
DIM	MIN	MAX
A	2.35	2.65
A1	0.10	0.25
B	0.35	0.49
C	0.23	0.32
D	12.65	12.95
E	7.40	7.60
e	1.27 BSC	
H	10.05	10.55
h	0.25	0.75
L	0.50	0.90
θ	0°	7°

ECLinPS is a trademark of Semiconductor Components Industries, LLC (SCILLC).

**ON Semiconductor** and **ON** are registered trademarks of Semiconductor Components Industries, LLC (SCILLC). SCILLC reserves the right to make changes without further notice to any products herein. SCILLC makes no warranty, representation or guarantee regarding the suitability of its products for any particular purpose, nor does SCILLC assume any liability arising out of the application or use of any product or circuit, and specifically disclaims any and all liability, including without limitation special, consequential or incidental damages. "Typical" parameters which may be provided in SCILLC data sheets and/or specifications can and do vary in different applications and actual performance may vary over time. All operating parameters, including "Typicals" must be validated for each customer application by customer's technical experts. SCILLC does not convey any license under its patent rights nor the rights of others. SCILLC products are not designed, intended, or authorized for use as components in systems intended for surgical implant into the body, or other applications intended to support or sustain life, or for any other application in which the failure of the SCILLC product could create a situation where personal injury or death may occur. Should Buyer purchase or use SCILLC products for any such unintended or unauthorized application, Buyer shall indemnify and hold SCILLC and its officers, employees, subsidiaries, affiliates, and distributors harmless against all claims, costs, damages, and expenses, and reasonable attorney fees arising out of, directly or indirectly, any claim of personal injury or death associated with such unintended or unauthorized use, even if such claim alleges that SCILLC was negligent regarding the design or manufacture of the part. SCILLC is an Equal Opportunity/Affirmative Action Employer. This literature is subject to all applicable copyright laws and is not for resale in any manner.

### PUBLICATION ORDERING INFORMATION

**LITERATURE FULFILLMENT:**  
Literature Distribution Center for ON Semiconductor  
P.O. Box 5163, Denver, Colorado 80217 USA  
**Phone:** 303-675-2175 or 800-344-3860 Toll Free USA/Canada  
**Fax:** 303-675-2176 or 800-344-3867 Toll Free USA/Canada  
**Email:** orderlit@onsemi.com

**N. American Technical Support:** 800-282-9855 Toll Free  
USA/Canada  
**Europe, Middle East and Africa Technical Support:**  
Phone: 421 33 790 2910  
**Japan Customer Focus Center**  
Phone: 81-3-5773-3850

**ON Semiconductor Website:** [www.onsemi.com](http://www.onsemi.com)  
**Order Literature:** <http://www.onsemi.com/orderlit>

For additional information, please contact your local Sales Representative

## Looking for pricing, stock, or lifecycle information?

Click below to explore more details on WIN SOURCE:

 [View MC100EL59DW](#) on WIN SOURCE

 [ON Semiconductor](#) Information

## Optimize Your Supply Chain with WIN SOURCE Solutions

-  Global Sourcing Solution
-  Obsolete Management
-  Cost Control Management
-  Shortage Management
-  Alternative Solution
-  Excess Inventory Management