



THE DATASHEET OF LM385BMX/NOPB



LM185/LM285/LM385 Adjustable Micropower Voltage References

 Check for Samples: [LM185-ADJ](#), [LM285-ADJ](#), [LM385-ADJ](#)

FEATURES

- Adjustable from 1.24V to 5.30V
- Operating Current of 10 μ A to 20mA
- 1% and 2% Initial Tolerance
- 1 Ω Dynamic Impedance
- Low Temperature Coefficient

DESCRIPTION

The LM185/LM285/LM385 are micropower 3-terminal adjustable band-gap voltage reference diodes. Operating from 1.24 to 5.3V and over a 10 μ A to 20mA current range, they feature exceptionally low dynamic impedance and good temperature stability. On-chip trimming is used to provide tight voltage tolerance. Since the LM185 band-gap reference uses only transistors and resistors, low noise and good long-term stability result.

Careful design of the LM185 has made the device tolerant of capacitive loading, making it easy to use in almost any reference application. The wide dynamic operating range allows its use with widely varying supplies with excellent regulation.

The extremely low power drain of the LM185 makes it useful for micropower circuitry. This voltage reference can be used to make portable meters, regulators or general purpose analog circuitry with battery life approaching shelf life. Further, the wide operating current allows it to replace older references with a tighter tolerance part.

The LM185 is rated for operation over a -55°C to 125°C temperature range, while the LM285 is rated -40°C to 85°C and the LM385 0°C to 70°C . The LM185 is available in a hermetic TO package and a LCCC package, while the LM285/LM385 are available in a low-cost TO-92 package, as well as SOIC.

Connection Diagram

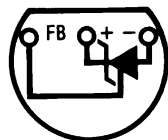

Figure 1. TO-92 Package Bottom View

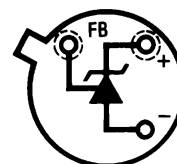

Figure 2. TO Package Bottom View

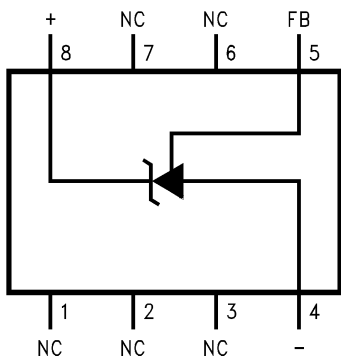

Figure 3. SOIC Package Top View

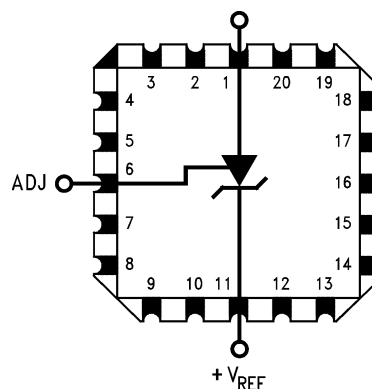

Figure 4. 20-LCCC Top View



Please be aware that an important notice concerning availability, standard warranty, and use in critical applications of Texas Instruments semiconductor products and disclaimers thereto appears at the end of this data sheet.

All trademarks are the property of their respective owners.

Block Diagram

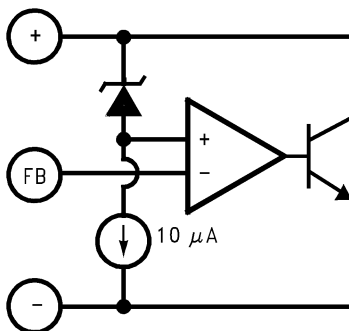

Typical Applications

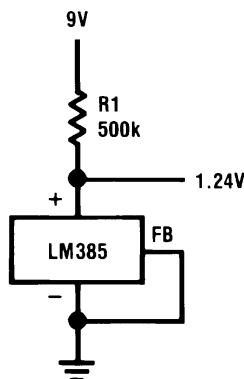
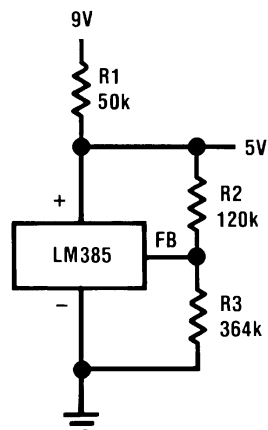

Figure 5. 1.24V Reference



$$V_{OUT} = 1.24 \left(\frac{R3}{R2} + 1 \right)$$

Figure 6. 5.0V Reference



These devices have limited built-in ESD protection. The leads should be shorted together or the device placed in conductive foam during storage or handling to prevent electrostatic damage to the MOS gates.

Absolute Maximum Ratings⁽¹⁾⁽²⁾⁽³⁾

Reverse Current	30mA
Forward Current	10mA
Operating Temperature Range ⁽⁴⁾	
LM185 Series	–55°C to 125°C
LM285 Series	–40°C to 85°C
LM385 Series	0°C to 70°C
ESD Susceptibility ⁽⁵⁾	2kV
Storage Temperature	–55°C to 150°C
Soldering Information	
TO-92 Package (10 sec.)	260°C
TO Package (10 sec.)	300°C
SOIC Package	
Vapor Phase (60 sec.)	215°C
Infrared (15 sec.)	220°C
See An-450 "Surface Mounting Methods and Their Effect on Product Reliability" for other methods of soldering surface mount devices.	

- (1) Absolute Maximum Ratings indicate limits beyond which damage to the device may occur. Operating Ratings indicate conditions for which the device is intended to be functional. For specifications and test conditions, see the Electrical Characteristics. The specifications apply only for the test conditions listed.
- (2) Refer to RETS185H for military specifications.
- (3) If Military/Aerospace specified devices are required, please contact the TI Sales Office/Distributors for availability and specifications.
- (4) For elevated temperature operation, see [Table 1](#) and [Thermal Characteristics](#).
- (5) The human body model is a 100 pF capacitor discharged through a 1.5 kΩ resistor into each pin.

Table 1. $T_{J(max)}$ for Elevated Temperature Operation

DEVICE	$T_{J(max)}$ (°C)
LM185	150
LM285	125
LM385	100

Thermal Characteristics

Over operating free-air temperature range (unless otherwise noted)

Thermal Resistance	TO-92	TO-46	SOIC
θ_{JA} (Junction to Ambient)	180°C/W (0.4" leads)	440°C/W	165°C/W
	170°C/W (0.125" leads)		
θ_{JC} (Junction to Case)	N/A	80°C/W	N/A

Electrical Characteristics⁽¹⁾

Parameter	Conditions	LM185, LM285					LM385					Units (Limit)
		Typ	LM185BX, LM185BY, LM185B, LM285BX, LM285BY		LM285		Typ	LM385BX, LM385BY		LM385		
			Tested Limit (2)	Design Limit (3)	Tested Limit (2)	Design Limit (3)		Tested Limit (2)	Design Limit (3)	Tested Limit (2)	Design Limit (3)	
Reference Voltage	$I_R = 100\mu A$	1.240	1.252		1.265	1.270	1.240	1.252	1.255	1.265	1.270	V (max)
			1.228		1.215	1.205		1.228	1.215	1.215	1.205	V (min)
Reference Voltage Change with Current	$I_{MIN} < I_R < 1mA$	0.2	1	1.5	1	1.5	0.2	1	1.5	1	1.5	mV (max)
	$1mA < I_R < 20mA$	4	10	20	10	20	5	15	25	15	25	
Dynamic Output Impedance	$I_R = 100\mu A, f = 100Hz$ $I_{AC} = 0.1 I_R$ $V_{OUT} = V_{REF}$ $V_{OUT} = 5.3V$	0.3					0.4					Ω
		0.7					1					
Reference Voltage Change with Output Voltage	$I_R = 100\mu A$	1	3	6	3	6	2	5	10	5	10	mV (max)
Feedback Current		13	20	25	20	25	16	30	35	30	35	nA (max)
Minimum Operating Current (see curve)	$V_{OUT} = V_{REF}$	6	9	10	9	10	7	11	13	11	13	μA (max)
	$V_{OUT} = 5.3V$	30	45	50	45	50	35	55	60	55	60	
Output Wideband Noise	$I_R = 100\mu A, 10Hz < f < 10kHz$ $V_{OUT} = V_{REF}$ $V_{OUT} = 5.3V$	50					50					μV_{rms}
		170					170					
Average Temperature Coefficient ⁽⁴⁾	$I_R = 100\mu A$	X Suffix		30				30				ppm/ $^{\circ}C$ (max)
		Y Suffix		50				50				
		All Others			150		150		150		150	
Long Term Stability	$I_R = 100\mu A, T = 1000 Hr,$ $T_A = 25^{\circ}C \pm 0.1^{\circ}C$	20					20					ppm

- (1) Parameters identified with **boldface type** apply at temperature extremes. All other numbers apply at $T_A = T_J = 25^{\circ}C$. Unless otherwise specified, all parameters apply for $V_{REF} < V_{OUT} < 5.3V$.
- (2) Production tested.
- (3) Not production tested. These limits are not to be used to calculate average outgoing quality levels.
- (4) The average temperature coefficient is defined as the maximum deviation of reference voltage at all measured temperatures from T_{MIN} to T_{MAX} , divided by $T_{MAX} - T_{MIN}$. The measured temperatures are -55, -40, 0, 25, 70, 85, 125 $^{\circ}C$.

Typical Performance Characteristics

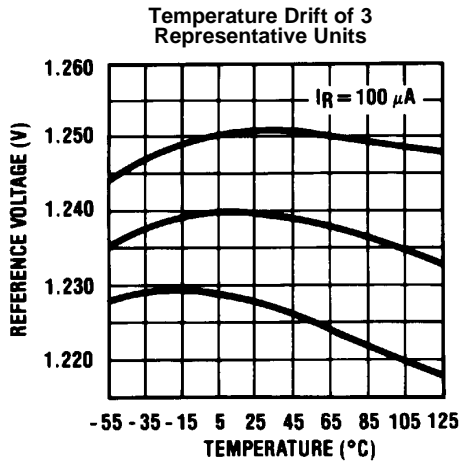

Figure 7.

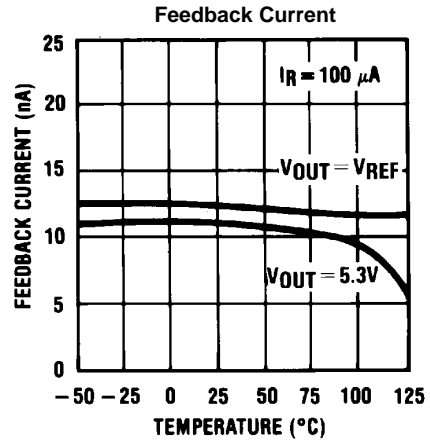

Figure 8.

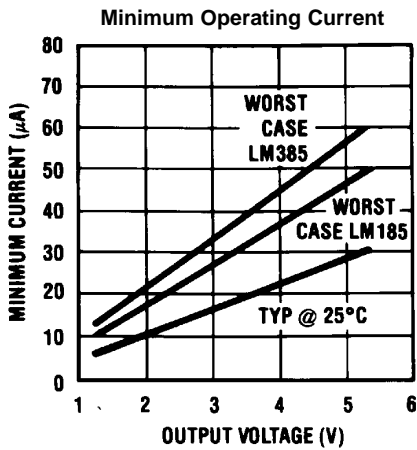

Figure 9.

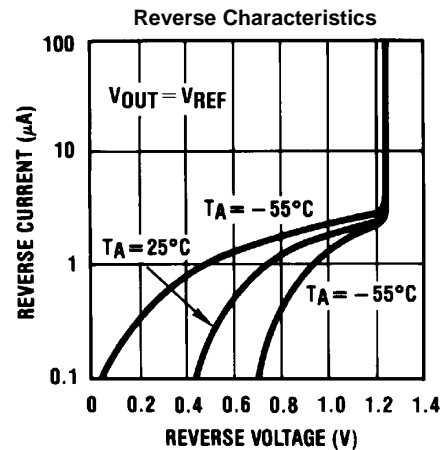

Figure 10.

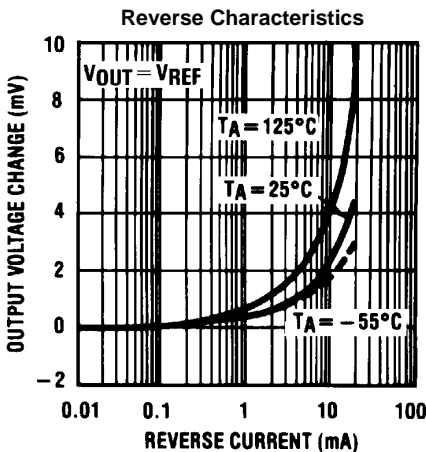

Figure 11.

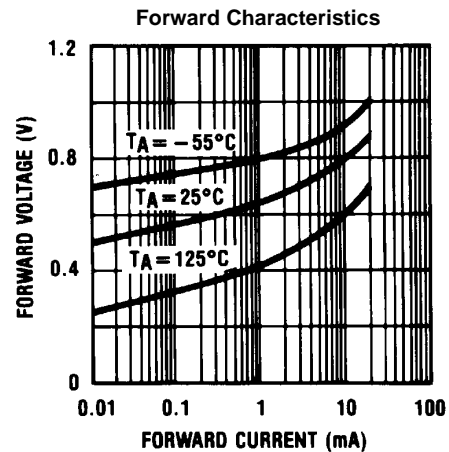

Figure 12.

Typical Performance Characteristics (continued)

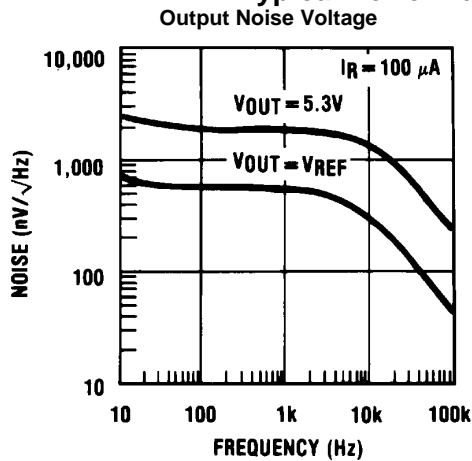

Figure 13.

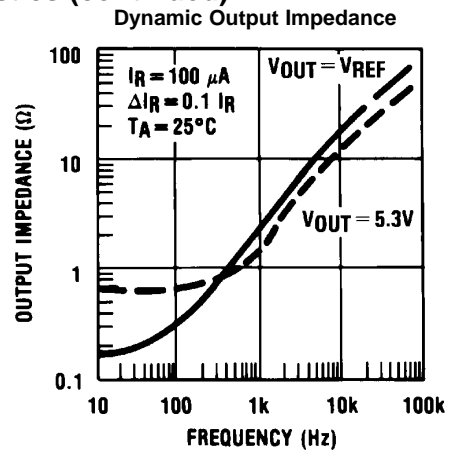

Figure 14.

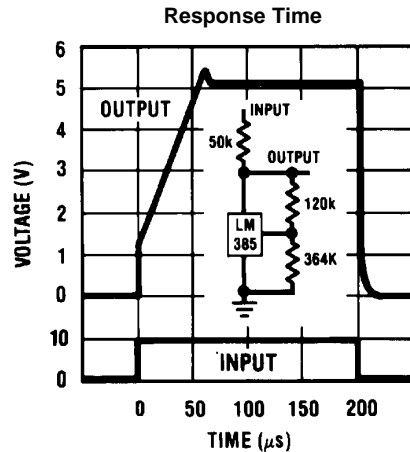

Figure 15.

Temperature Coefficient Typical
LM185 (left), LM285 (center), LM385 (right)

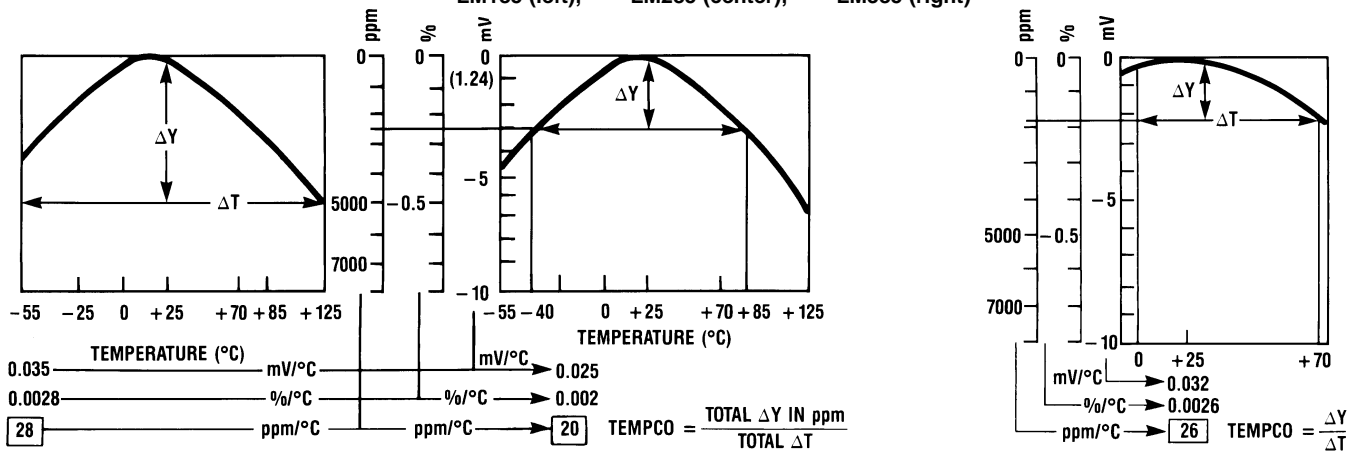

Figure 16.

TYPICAL APPLICATIONS

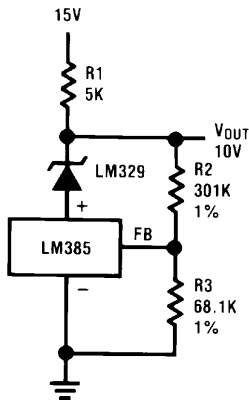

Figure 17. Precision 10V Reference

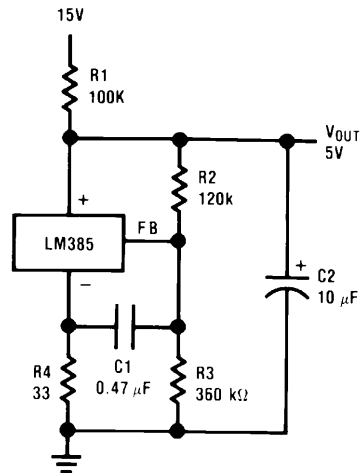

Figure 18. Low AC Noise Reference

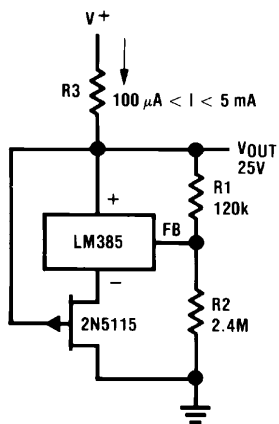

Figure 19. 25V Low Current Shunt Regulator

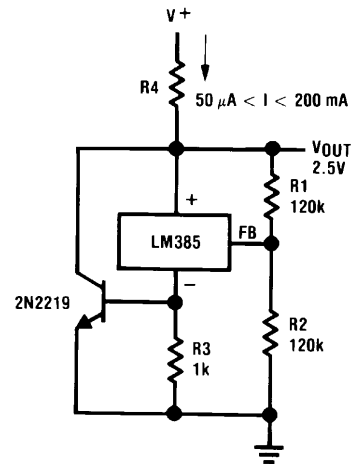

Figure 20. 200 mA Shunt Regulator

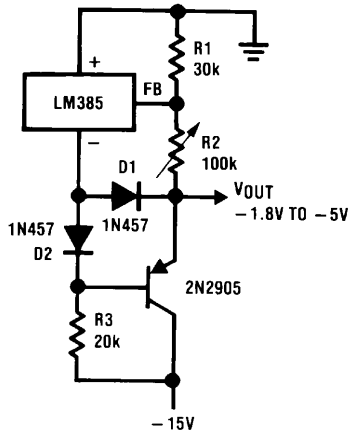

Figure 21. Series-Shunt 20 mA Regulator

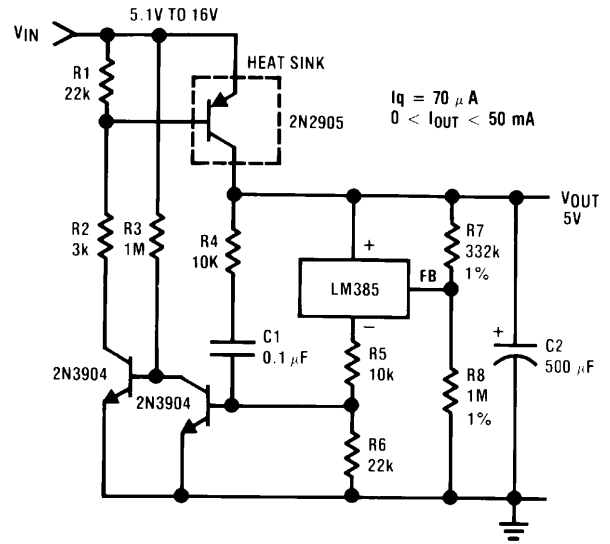

Figure 22. High Efficiency Low Power Regulator

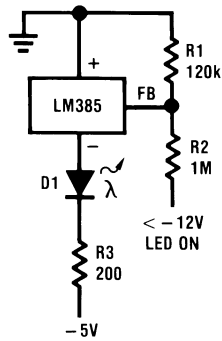

Figure 23. Voltage Level Detector

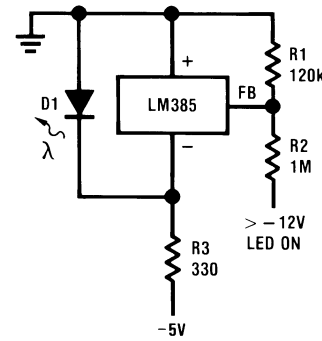

Figure 24. Voltage Level Detector

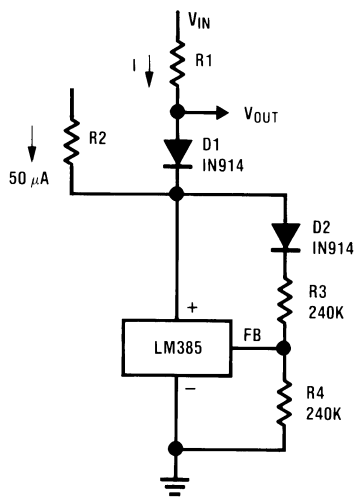

Figure 25. Fast Positive Clamp
 $2.4V + \Delta V_{D1}$

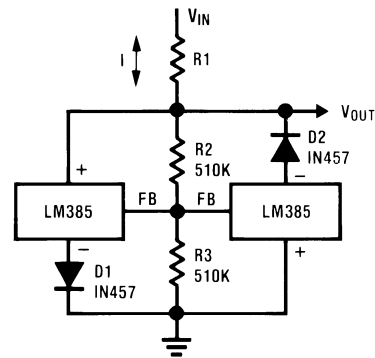

Figure 26. Bidirectional Clamp
 $\pm 2.4V$

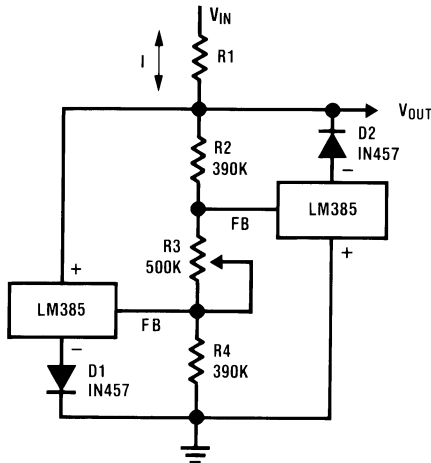

Figure 27. Bidirectional Adjustable Clamp
±1.8V to ±2.4V

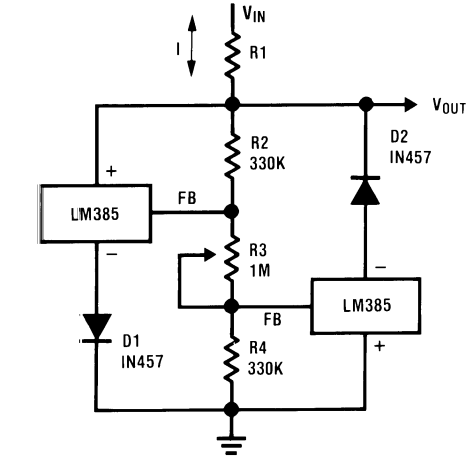

Figure 28. Bidirectional Adjustable Clamp
±2.4V to ±6V

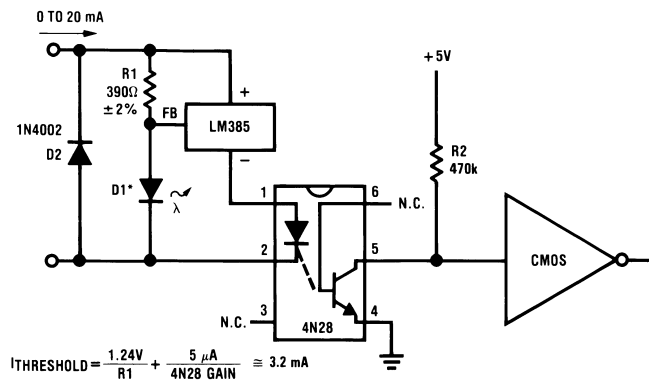

Figure 29. Simple Floating Current Detector

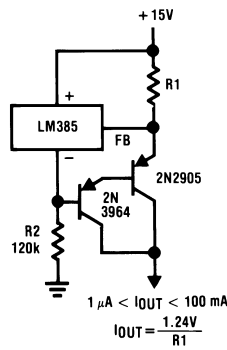
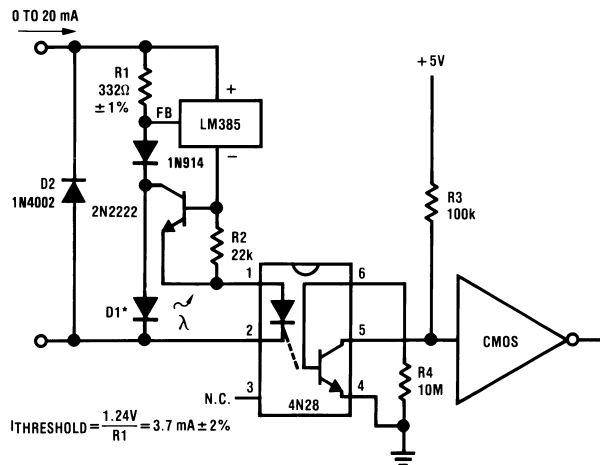

Figure 30. Current Source



*D1 can be any LED, $V_F=1.5\text{V to } 2.2\text{V}$ at 3 mA . D1 may act as an indicator. D1 will be on if $I_{\text{THRESHOLD}}$ falls below the threshold current, except with $I=0$.

Figure 31. Precision Floating Current Detector

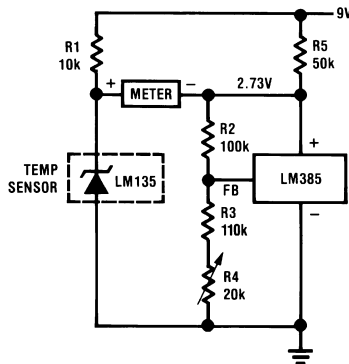

Figure 32. Centigrade Thermometer, 10mV/°C

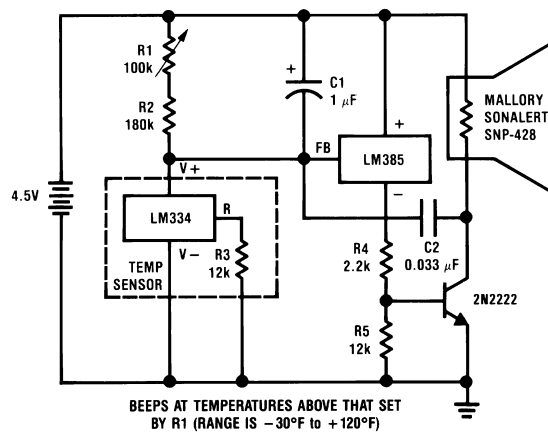
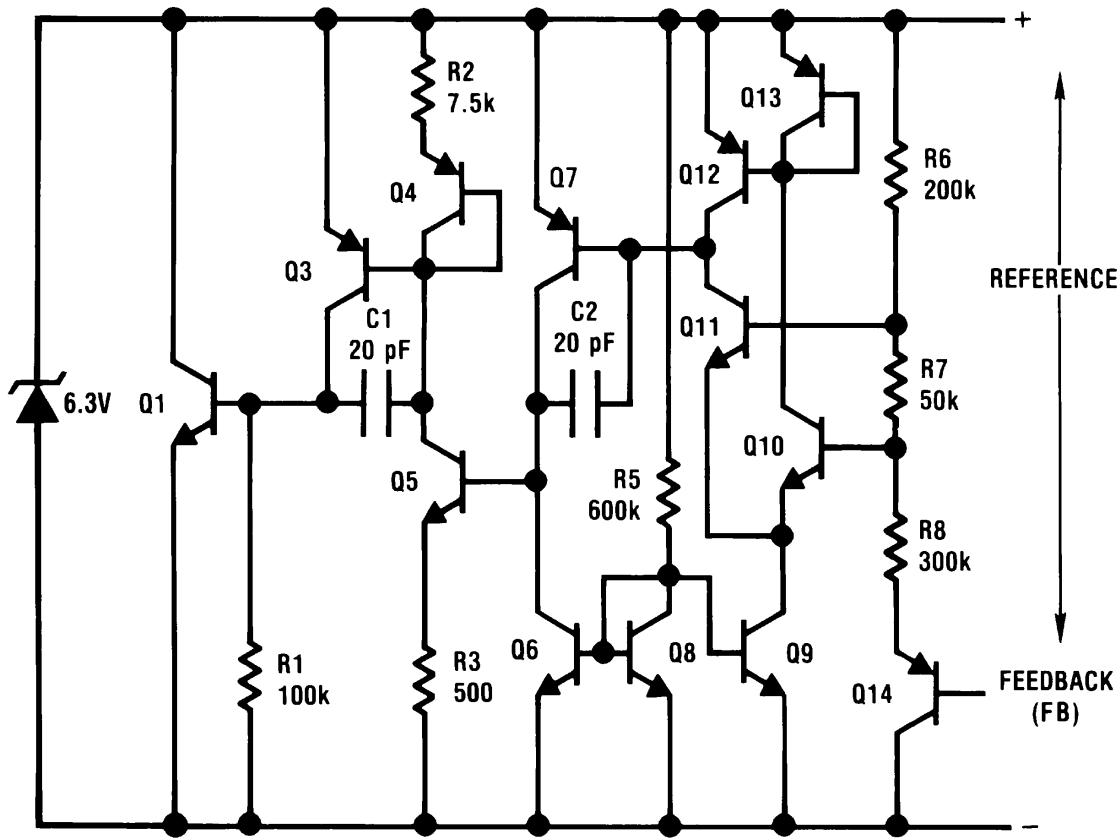

Figure 33. Freezer Alarm

Schematic Diagram



REVISION HISTORY

Changes from Revision E (April 2013) to Revision F	Page
• Changed layout of National Data Sheet to TI format	11

PACKAGING INFORMATION

Orderable Device	Status (1)	Package Type	Package Drawing	Pins	Package Qty	Eco Plan (2)	Lead finish/ Ball material (6)	MSL Peak Temp (3)	Op Temp (°C)	Device Marking (4/5)	Samples
LM185BH	ACTIVE	TO	NDV	3	1000	RoHS & Green	Call TI	Level-1-NA-UNLIM	-55 to 125	(LM185BH, LM185BH)	Samples
LM185BH/NOPB	ACTIVE	TO	NDV	3	1000	RoHS & Green	Call TI	Level-1-NA-UNLIM	-55 to 125	(LM185BH, LM185BH)	Samples
LM285BXZ/NOPB	ACTIVE	TO-92	LP	3	1800	RoHS & Green	Call TI	N / A for Pkg Type	-40 to 85	LM285 BXZ	Samples
LM285BYM/NOPB	ACTIVE	SOIC	D	8	95	RoHS & Green	SN	Level-1-260C-UNLIM	-40 to 85	LM285 BYM	Samples
LM285BYMX/NOPB	ACTIVE	SOIC	D	8	2500	RoHS & Green	SN	Level-1-260C-UNLIM	-40 to 85	LM285 BYM	Samples
LM285BYZ/NOPB	ACTIVE	TO-92	LP	3	1800	RoHS & Green	Call TI	N / A for Pkg Type	-40 to 85	LM285 BYZ	Samples
LM285M/NOPB	ACTIVE	SOIC	D	8	95	RoHS & Green	SN	Level-1-260C-UNLIM	-40 to 85	LM285 M	Samples
LM285MX/NOPB	ACTIVE	SOIC	D	8	2500	RoHS & Green	SN	Level-1-260C-UNLIM	-40 to 85	LM285 M	Samples
LM285Z/NOPB	ACTIVE	TO-92	LP	3	1800	RoHS & Green	Call TI	N / A for Pkg Type	-40 to 85	LM285 Z	Samples
LM385BM/NOPB	ACTIVE	SOIC	D	8	95	RoHS & Green	SN	Level-1-260C-UNLIM	0 to 70	LM385 BM	Samples
LM385BMX/NOPB	ACTIVE	SOIC	D	8	2500	RoHS & Green	SN	Level-1-260C-UNLIM	0 to 70	LM385 BM	Samples
LM385BXZ/NOPB	ACTIVE	TO-92	LP	3	1800	RoHS & Green	Call TI	N / A for Pkg Type	0 to 70	LM385 BXZ	Samples
LM385BYZ/NOPB	ACTIVE	TO-92	LP	3	1800	RoHS & Green	Call TI	N / A for Pkg Type	0 to 70	LM385 BYZ	Samples
LM385BZ/NOPB	ACTIVE	TO-92	LP	3	1800	RoHS & Green	Call TI	N / A for Pkg Type	0 to 70	LM385 BZ	Samples
LM385M/NOPB	ACTIVE	SOIC	D	8	95	RoHS & Green	SN	Level-1-260C-UNLIM	0 to 70	LM385 M	Samples
LM385MX/NOPB	ACTIVE	SOIC	D	8	2500	RoHS & Green	SN	Level-1-260C-UNLIM	0 to 70	LM385 M	Samples
LM385Z/NOPB	ACTIVE	TO-92	LP	3	1800	RoHS & Green	Call TI	N / A for Pkg Type	0 to 70	LM385	Samples

Orderable Device	Status (1)	Package Type	Package Drawing	Pins	Package Qty	Eco Plan (2)	Lead finish/ Ball material (6)	MSL Peak Temp (3)	Op Temp (°C)	Device Marking (4/5)	Samples
										Z	

(1) The marketing status values are defined as follows:

ACTIVE: Product device recommended for new designs.

LIFEBUY: TI has announced that the device will be discontinued, and a lifetime-buy period is in effect.

NRND: Not recommended for new designs. Device is in production to support existing customers, but TI does not recommend using this part in a new design.

PREVIEW: Device has been announced but is not in production. Samples may or may not be available.

OBSELETE: TI has discontinued the production of the device.

(2) **RoHS:** TI defines "RoHS" to mean semiconductor products that are compliant with the current EU RoHS requirements for all 10 RoHS substances, including the requirement that RoHS substance do not exceed 0.1% by weight in homogeneous materials. Where designed to be soldered at high temperatures, "RoHS" products are suitable for use in specified lead-free processes. TI may reference these types of products as "Pb-Free".

RoHS Exempt: TI defines "RoHS Exempt" to mean products that contain lead but are compliant with EU RoHS pursuant to a specific EU RoHS exemption.

Green: TI defines "Green" to mean the content of Chlorine (Cl) and Bromine (Br) based flame retardants meet JS709B low halogen requirements of <=1000ppm threshold. Antimony trioxide based flame retardants must also meet the <=1000ppm threshold requirement.

(3) MSL, Peak Temp. - The Moisture Sensitivity Level rating according to the JEDEC industry standard classifications, and peak solder temperature.

(4) There may be additional marking, which relates to the logo, the lot trace code information, or the environmental category on the device.

(5) Multiple Device Markings will be inside parentheses. Only one Device Marking contained in parentheses and separated by a "~" will appear on a device. If a line is indented then it is a continuation of the previous line and the two combined represent the entire Device Marking for that device.

(6) Lead finish/Ball material - Orderable Devices may have multiple material finish options. Finish options are separated by a vertical ruled line. Lead finish/Ball material values may wrap to two lines if the finish value exceeds the maximum column width.

Important Information and Disclaimer:The information provided on this page represents TI's knowledge and belief as of the date that it is provided. TI bases its knowledge and belief on information provided by third parties, and makes no representation or warranty as to the accuracy of such information. Efforts are underway to better integrate information from third parties. TI has taken and continues to take reasonable steps to provide representative and accurate information but may not have conducted destructive testing or chemical analysis on incoming materials and chemicals. TI and TI suppliers consider certain information to be proprietary, and thus CAS numbers and other limited information may not be available for release.

In no event shall TI's liability arising out of such information exceed the total purchase price of the TI part(s) at issue in this document sold by TI to Customer on an annual basis.

TAPE AND REEL INFORMATION

QUADRANT ASSIGNMENTS FOR PIN 1 ORIENTATION IN TAPE

*All dimensions are nominal

Device	Package Type	Package Drawing	Pins	SPQ	Reel Diameter (mm)	Reel Width W1 (mm)	A0 (mm)	B0 (mm)	K0 (mm)	P1 (mm)	W (mm)	Pin1 Quadrant
LM285BYMX/NOPB	SOIC	D	8	2500	330.0	12.4	6.5	5.4	2.0	8.0	12.0	Q1
LM285MX/NOPB	SOIC	D	8	2500	330.0	12.4	6.5	5.4	2.0	8.0	12.0	Q1
LM385BMX/NOPB	SOIC	D	8	2500	330.0	12.4	6.5	5.4	2.0	8.0	12.0	Q1
LM385MX/NOPB	SOIC	D	8	2500	330.0	12.4	6.5	5.4	2.0	8.0	12.0	Q1

TAPE AND REEL BOX DIMENSIONS



*All dimensions are nominal

Device	Package Type	Package Drawing	Pins	SPQ	Length (mm)	Width (mm)	Height (mm)
LM285BYMX/NOPB	SOIC	D	8	2500	367.0	367.0	35.0
LM285MX/NOPB	SOIC	D	8	2500	367.0	367.0	35.0
LM385BMX/NOPB	SOIC	D	8	2500	367.0	367.0	35.0
LM385MX/NOPB	SOIC	D	8	2500	367.0	367.0	35.0

TUBE

*All dimensions are nominal

Device	Package Name	Package Type	Pins	SPQ	L (mm)	W (mm)	T (μm)	B (mm)
LM285BYM/NOPB	D	SOIC	8	95	495	8	4064	3.05
LM285M/NOPB	D	SOIC	8	95	495	8	4064	3.05
LM385BM/NOPB	D	SOIC	8	95	495	8	4064	3.05
LM385M/NOPB	D	SOIC	8	95	495	8	4064	3.05

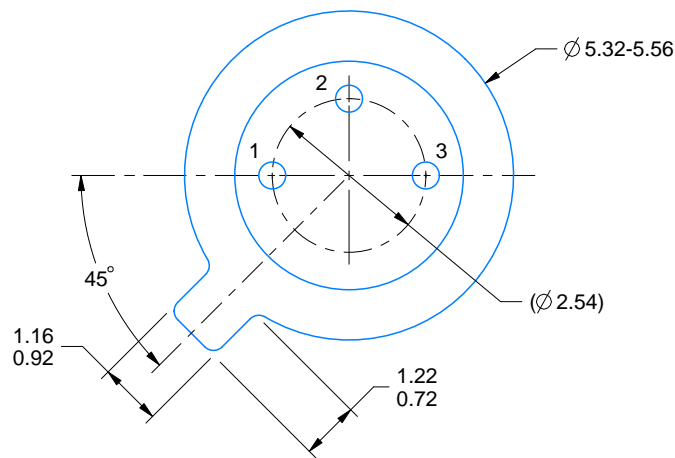
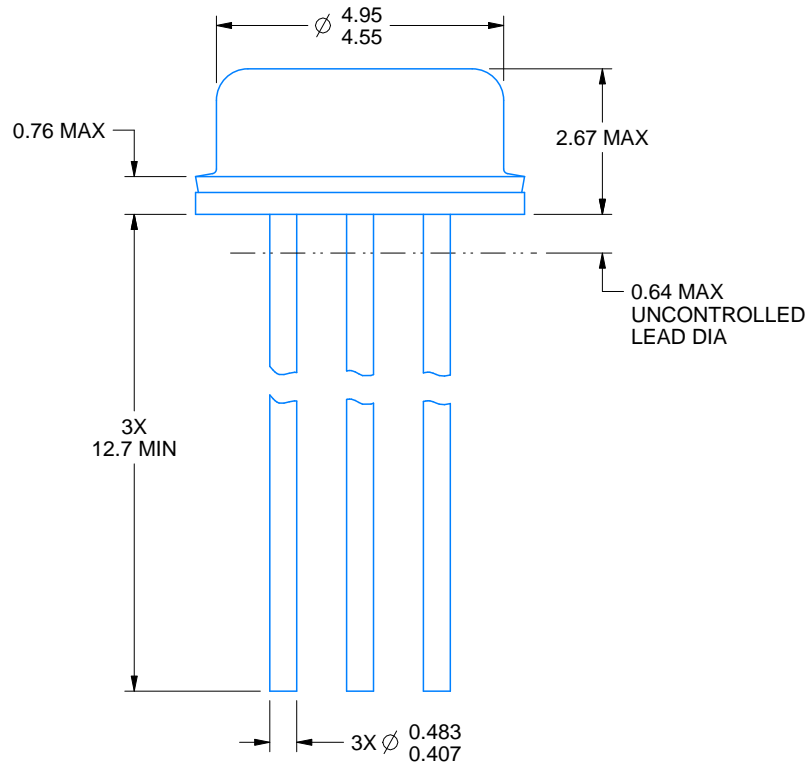

4219876/A 01/2017

NOTES:

1. All linear dimensions are in millimeters. Any dimensions in parenthesis are for reference only. Dimensioning and tolerancing per ASME Y14.5M.
2. This drawing is subject to change without notice.
3. Reference JEDEC registration TO-46.

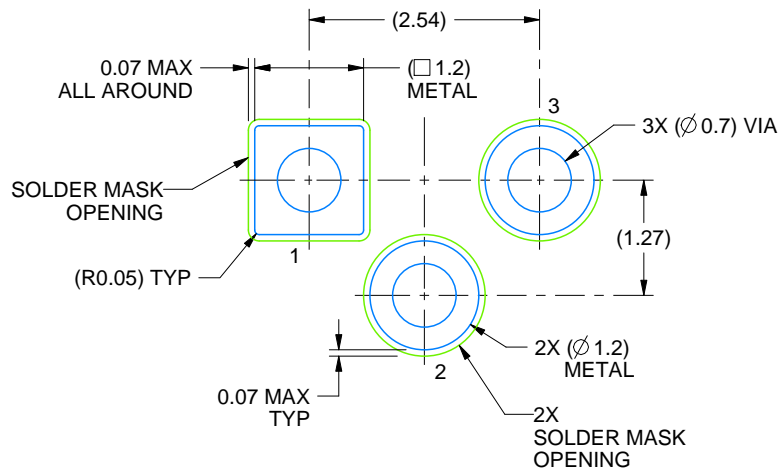

LAND PATTERN EXAMPLE
NON-SOLDER MASK DEFINED
SCALE:12X



D0008A

PACKAGE OUTLINE

SOIC - 1.75 mm max height

SMALL OUTLINE INTEGRATED CIRCUIT



4214825/C 02/2019

NOTES:

- Linear dimensions are in inches [millimeters]. Dimensions in parenthesis are for reference only. Controlling dimensions are in inches. Dimensioning and tolerancing per ASME Y14.5M.
- This drawing is subject to change without notice.
- This dimension does not include mold flash, protrusions, or gate burrs. Mold flash, protrusions, or gate burrs shall not exceed .006 [0.15] per side.
- This dimension does not include interlead flash.
- Reference JEDEC registration MS-012, variation AA.

EXAMPLE BOARD LAYOUT

D0008A

SOIC - 1.75 mm max height

SMALL OUTLINE INTEGRATED CIRCUIT

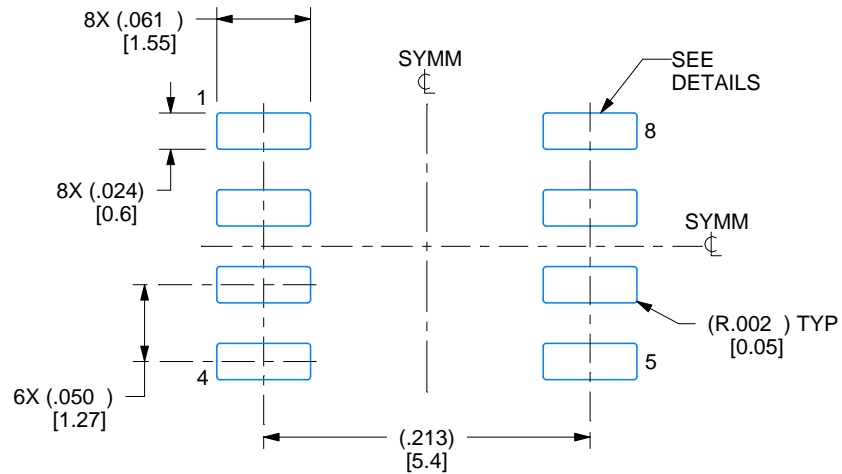

LAND PATTERN EXAMPLE
EXPOSED METAL SHOWN
SCALE:8X

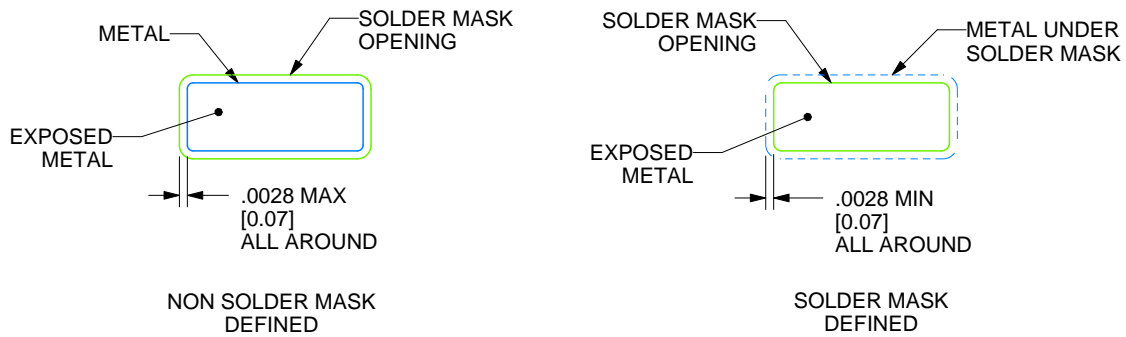

SOLDER MASK DETAILS

4214825/C 02/2019

NOTES: (continued)

- 6. Publication IPC-7351 may have alternate designs.
- 7. Solder mask tolerances between and around signal pads can vary based on board fabrication site.

EXAMPLE STENCIL DESIGN

D0008A

SOIC - 1.75 mm max height

SMALL OUTLINE INTEGRATED CIRCUIT



SOLDER PASTE EXAMPLE
BASED ON .005 INCH [0.125 MM] THICK STENCIL
SCALE:8X

4214825/C 02/2019

NOTES: (continued)

8. Laser cutting apertures with trapezoidal walls and rounded corners may offer better paste release. IPC-7525 may have alternate design recommendations.
9. Board assembly site may have different recommendations for stencil design.

GENERIC PACKAGE VIEW

LP 3

TO-92 - 5.34 mm max height

TRANSISTOR OUTLINE



Images above are just a representation of the package family, actual package may vary.
Refer to the product data sheet for package details.

4040001-2/F

LP0003A



PACKAGE OUTLINE

TO-92 - 5.34 mm max height

TO-92

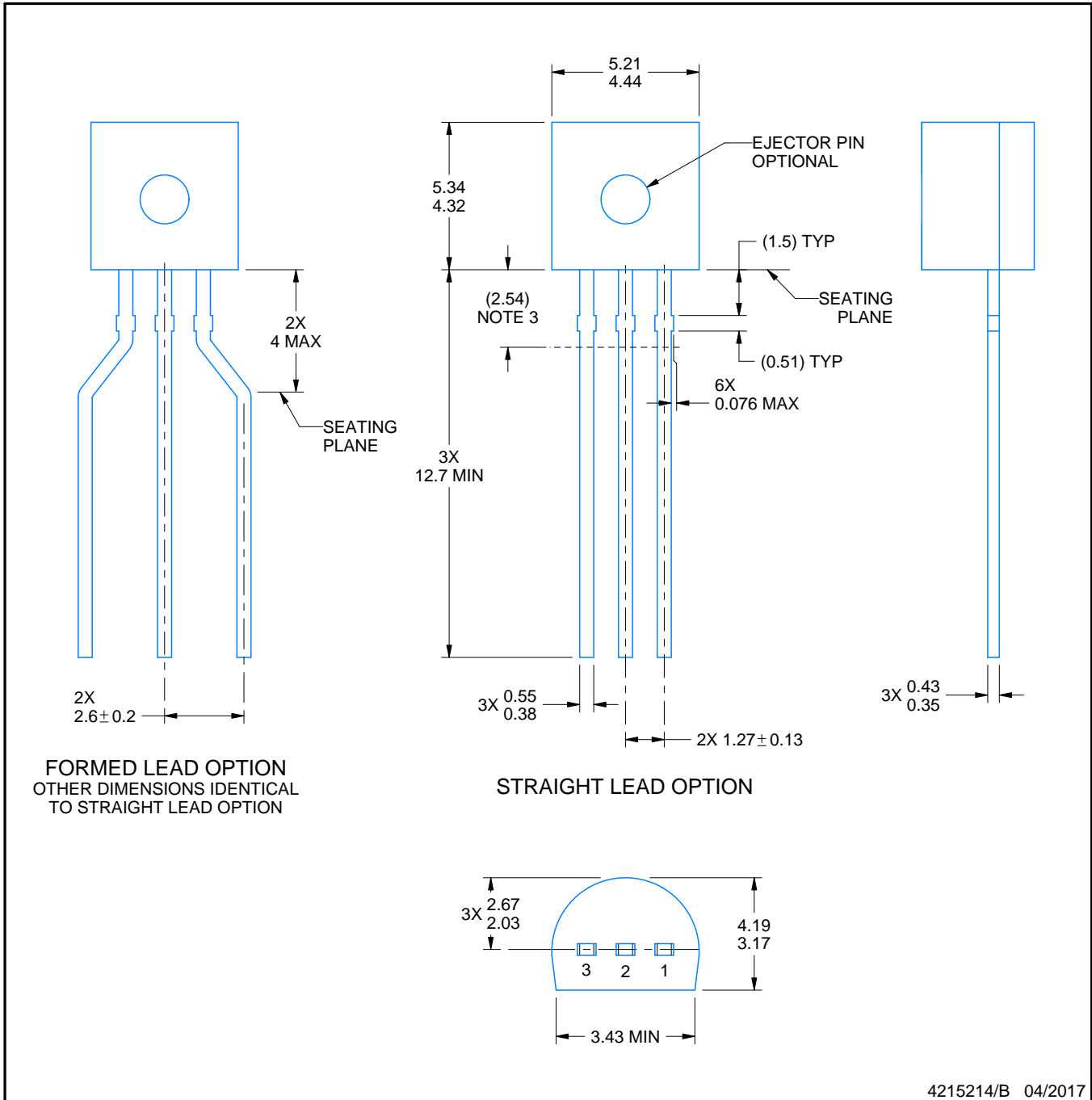

4215214/B 04/2017

NOTES:

1. All linear dimensions are in millimeters. Any dimensions in parenthesis are for reference only. Dimensioning and tolerancing per ASME Y14.5M.
2. This drawing is subject to change without notice.
3. Lead dimensions are not controlled within this area.
4. Reference JEDEC TO-226, variation AA.
5. Shipping method:
 - a. Straight lead option available in bulk pack only.
 - b. Formed lead option available in tape and reel or ammo pack.
 - c. Specific products can be offered in limited combinations of shipping medium and lead options.
 - d. Consult product folder for more information on available options.

EXAMPLE BOARD LAYOUT

LP0003A

TO-92 - 5.34 mm max height

TO-92

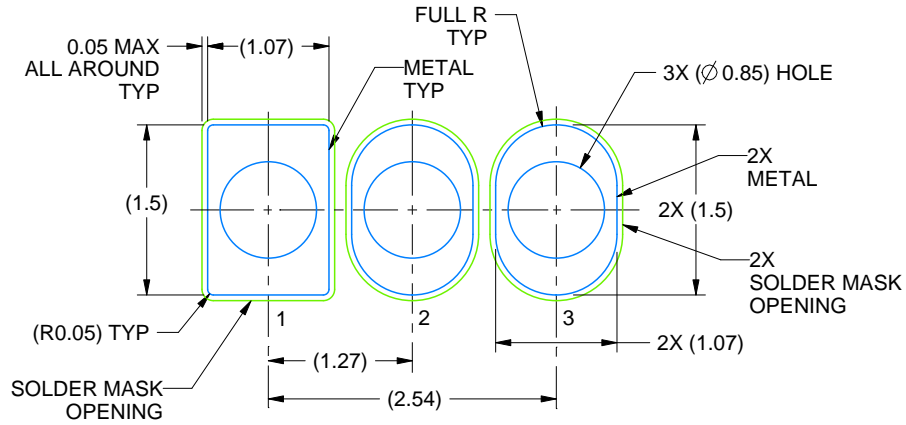

LAND PATTERN EXAMPLE
STRAIGHT LEAD OPTION
NON-SOLDER MASK DEFINED
SCALE:15X



LAND PATTERN EXAMPLE
FORMED LEAD OPTION
NON-SOLDER MASK DEFINED
SCALE:15X

4215214/B 04/2017

TAPE SPECIFICATIONS

LP0003A

TO-92 - 5.34 mm max height

TO-92

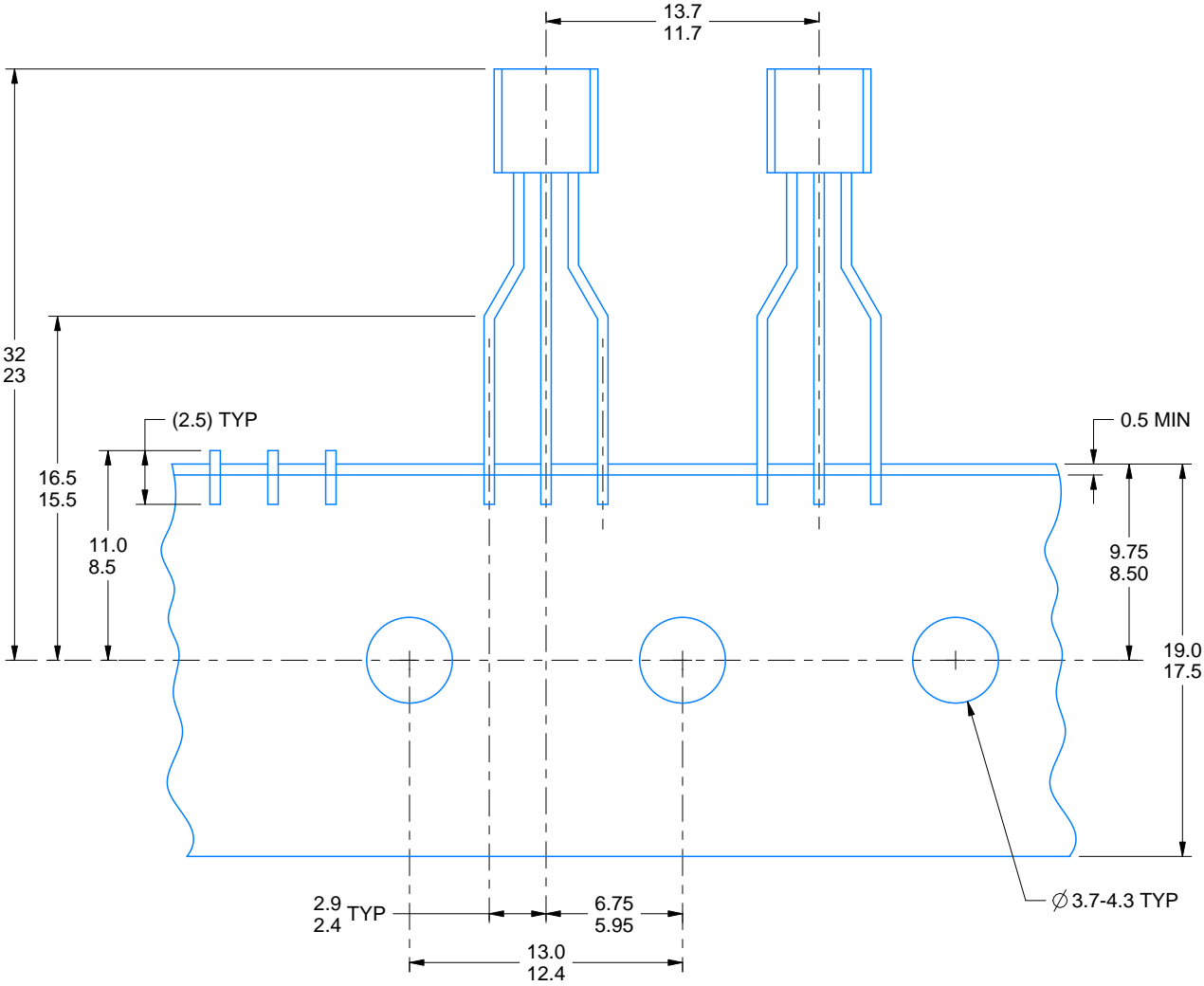

FOR FORMED LEAD OPTION PACKAGE

4215214/B 04/2017

IMPORTANT NOTICE AND DISCLAIMER

TI PROVIDES TECHNICAL AND RELIABILITY DATA (INCLUDING DATA SHEETS), DESIGN RESOURCES (INCLUDING REFERENCE DESIGNS), APPLICATION OR OTHER DESIGN ADVICE, WEB TOOLS, SAFETY INFORMATION, AND OTHER RESOURCES "AS IS" AND WITH ALL FAULTS, AND DISCLAIMS ALL WARRANTIES, EXPRESS AND IMPLIED, INCLUDING WITHOUT LIMITATION ANY IMPLIED WARRANTIES OF MERCHANTABILITY, FITNESS FOR A PARTICULAR PURPOSE OR NON-INFRINGEMENT OF THIRD PARTY INTELLECTUAL PROPERTY RIGHTS.

These resources are intended for skilled developers designing with TI products. You are solely responsible for (1) selecting the appropriate TI products for your application, (2) designing, validating and testing your application, and (3) ensuring your application meets applicable standards, and any other safety, security, regulatory or other requirements.

These resources are subject to change without notice. TI grants you permission to use these resources only for development of an application that uses the TI products described in the resource. Other reproduction and display of these resources is prohibited. No license is granted to any other TI intellectual property right or to any third party intellectual property right. TI disclaims responsibility for, and you will fully indemnify TI and its representatives against, any claims, damages, costs, losses, and liabilities arising out of your use of these resources.

TI's products are provided subject to [TI's Terms of Sale](#) or other applicable terms available either on [ti.com](https://www.ti.com) or provided in conjunction with such TI products. TI's provision of these resources does not expand or otherwise alter TI's applicable warranties or warranty disclaimers for TI products.

TI objects to and rejects any additional or different terms you may have proposed.

Mailing Address: Texas Instruments, Post Office Box 655303, Dallas, Texas 75265
Copyright © 2024, Texas Instruments Incorporated

Looking for pricing, stock, or lifecycle information?

Click below to explore more details on WIN SOURCE:

 [View LM385BMX/NOPB on WIN SOURCE](#)

 [Texas Instruments](#) Information

Optimize Your Supply Chain with WIN SOURCE Solutions

-  Global Sourcing Solution
-  Obsolete Management
-  Cost Control Management
-  Shortage Management
-  Alternative Solution
-  Excess Inventory Management