

32K/64K x 16/18 Dual-Port Static RAM

Features

- True dual-ported memory cells which allow simultaneous access of the same memory location
- 32K x 16 organization (CY7C027)
- 64K x 16 organization (CY7C028)
- 32K x 18 organization (CY7C037)
- 64K x 18 organization (CY7C038)
- 0.35 micron CMOS for optimum speed and power
- High speed access: 12^[1], 15, and 20 ns
- Low operating power
- Active: I_{CC} = 180 mA (typical)
- Standby: I_{SB3} = 0.05 mA (typical)
- Fully asynchronous operation
- Automatic power down
- Expandable data bus to 32 and 36 bits or more using Master/Slave chip select when using more than one device
- On-chip arbitration logic
- Semaphores included to permit software handshaking between ports
- INT flags for port-to-port communication
- Separate upper-byte and lower-byte control
- Dual chip enables
- Pin select for Master or Slave
- Commercial and industrial temperature ranges
- Available in 100-pin TQFP
- Pb-free packages available

Logic Block Diagram

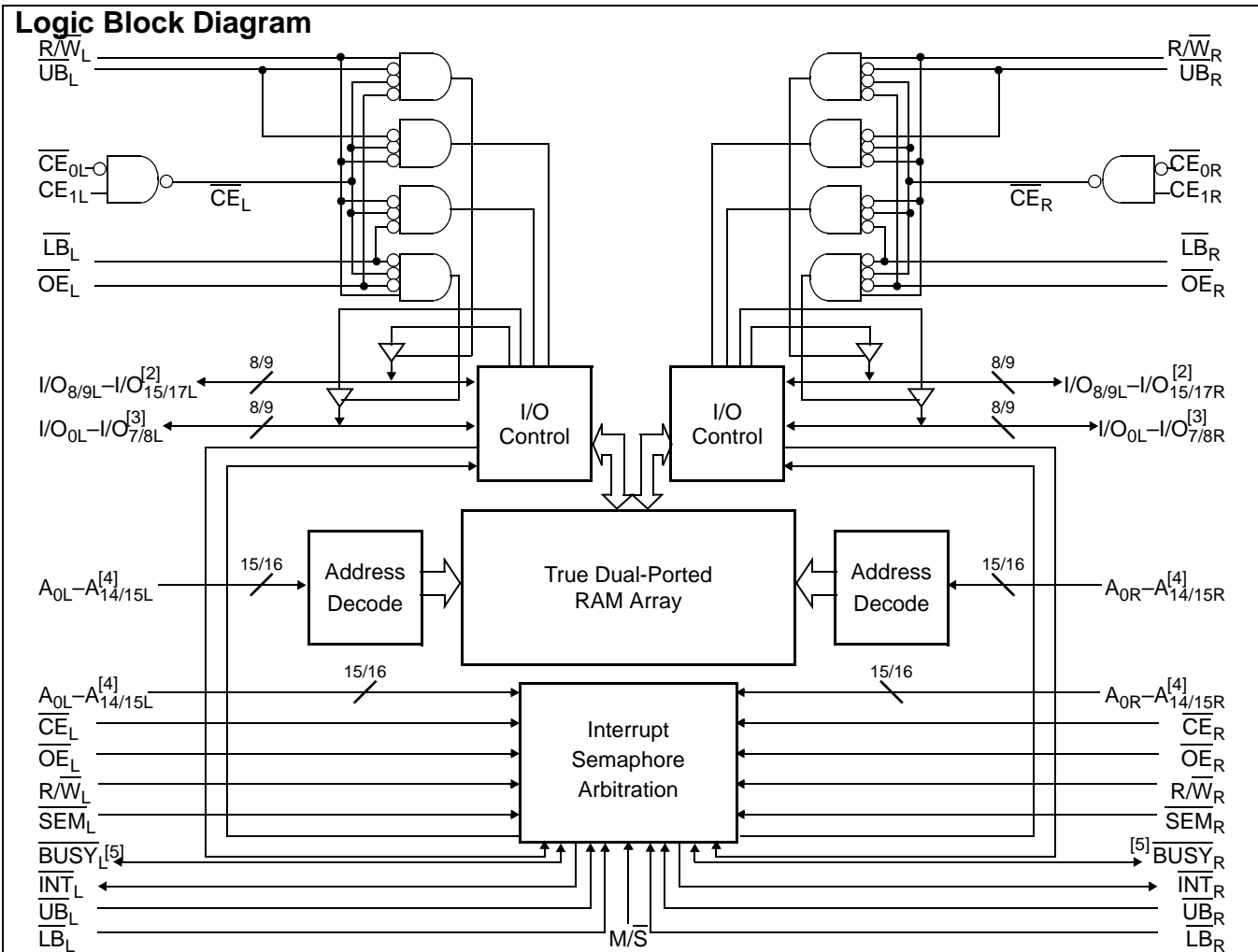

Notes

1. See page 6 for Load Conditions.
2. I/O₈-I/O₁₅ for x16 devices; I/O₉-I/O₁₇ for x18 devices.
3. I/O₀-I/O₇ for x16 devices; I/O₀-I/O₈ for x18 devices.
4. A₀-A₄ for 32K; A₀-A₁₅ for 64K devices.
5. BUSY is an output in master mode and an input in slave mode.

Functional Description

The CY7C027/028 and CY7C037/038 are low power CMOS 32K, 64K x 16/18 dual-port static RAMs. Various arbitration schemes are included on the devices to handle situations when multiple processors access the same piece of data. Two ports are provided, permitting independent, asynchronous access for reads and writes to any location in memory. The devices can be used as standalone 16 and 18-bit dual-port static RAMs or multiple devices can be combined to function as a 32/36-bit or wider master/slave dual-port static RAM. An M/S pin is provided for implementing 32/36-bit or wider memory applications without the need for separate master and slave devices or additional discrete logic. Application areas include interprocessor and multiprocessor designs, communications status buffering, and dual-port video/graphics memory.

Each port has independent control pins: dual chip enables (\overline{CE}_0 and CE_1), read or write enable (R/W), and output enable (\overline{OE}). Two flags are provided on each port (BUSY and INT). BUSY signals that the port is trying to access the same location currently being accessed by the other port. The interrupt flag (INT) permits communication between ports or systems by means of a mail box. The semaphores are used to pass a flag, or token, from one port to the other to indicate that a shared resource is in use. The semaphore logic is comprised of eight shared latches. Only one side can control the latch (semaphore) at any time. Control of a semaphore indicates that a shared resource is in use. An automatic power down feature is controlled independently on each port by the chip enable pins.

The CY7C027/028 and CY7C037/038 are available in 100-pin Thin Quad Plastic Flatpack (TQFP) packages.

Pin Configurations

Figure 1. 100-Pin TQFP (Top View)

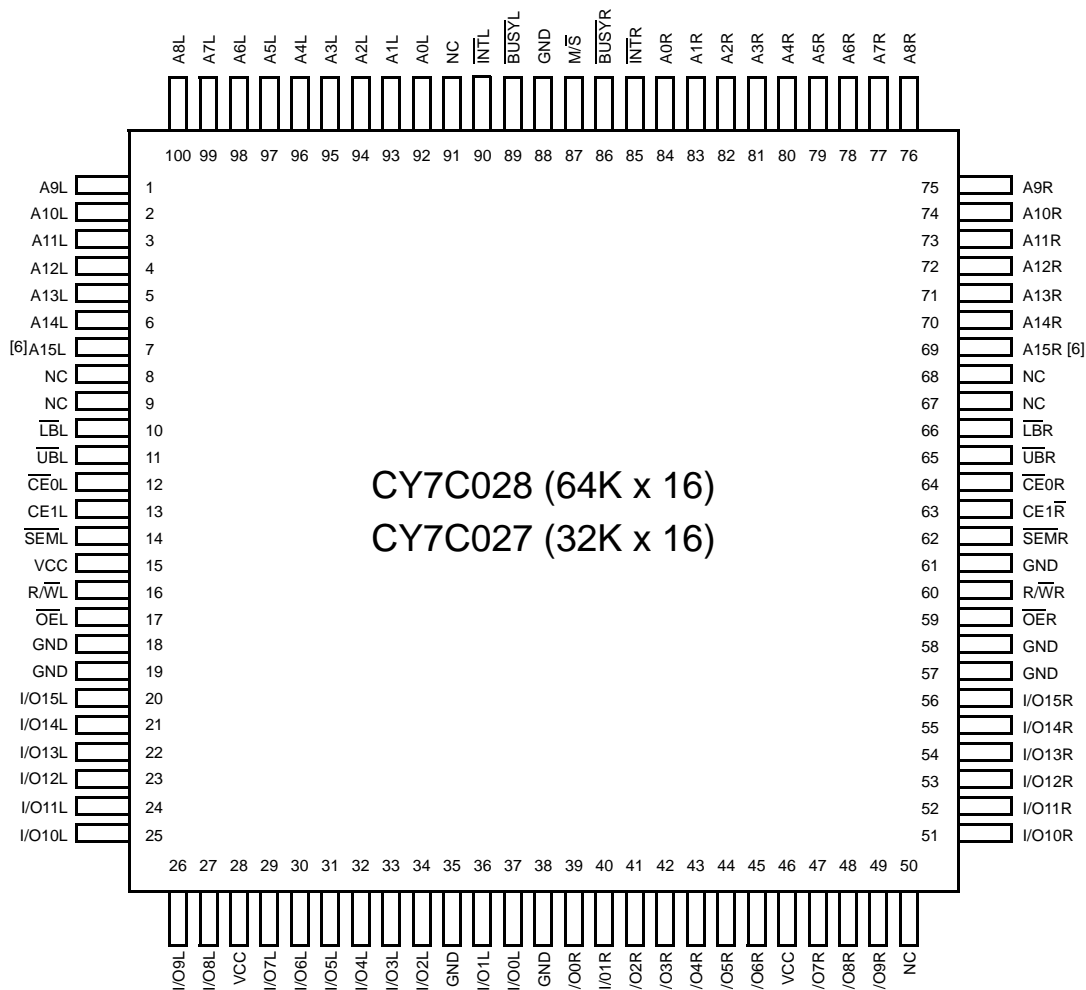

Note

6. This pin is NC for CY7C027.

Pin Configurations (continued)

Figure 2. 100-Pin TQFP (Top View)

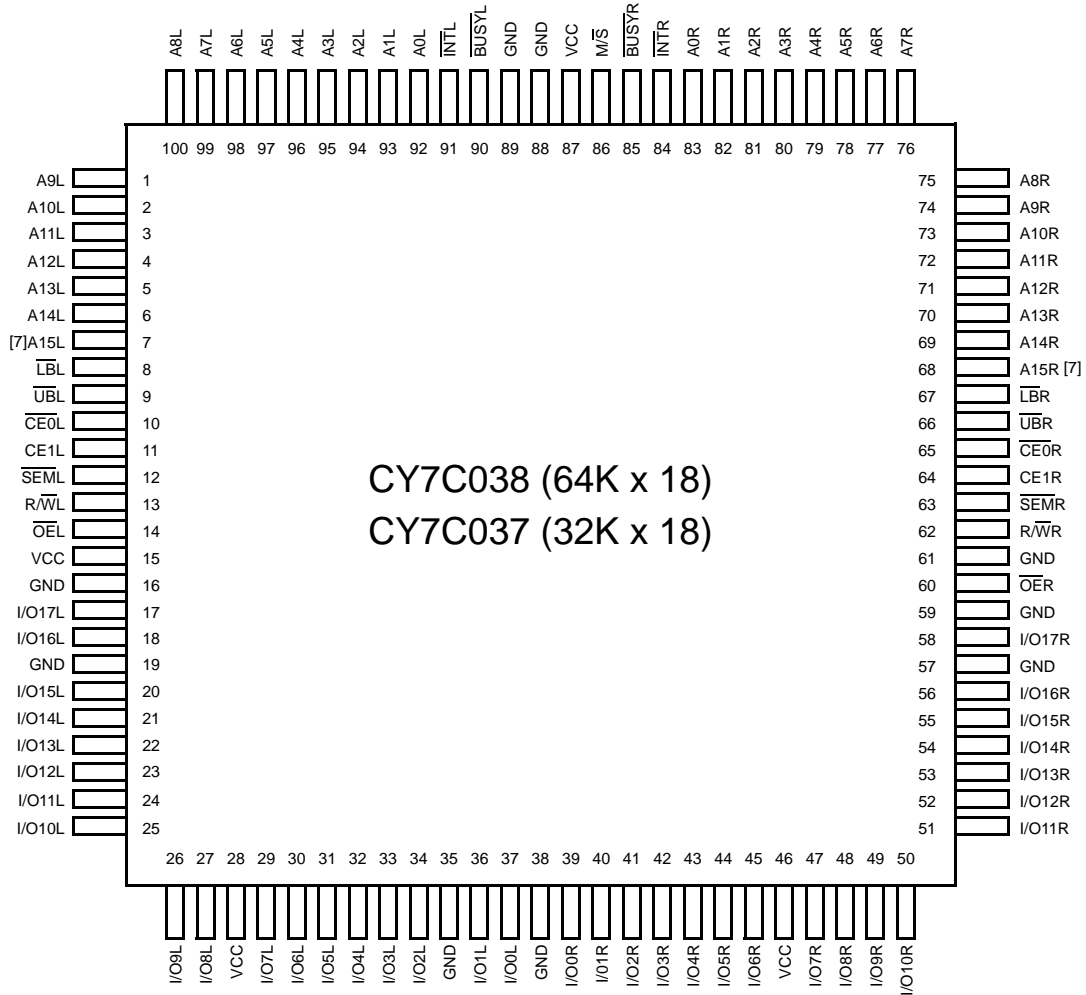

Selection Guide

Parameter	CY7C027/028 CY7C037/038 -12 ^[1]	CY7C027/028 CY7C037/038 -15	CY7C027/028 CY7C037/038 -20	Unit
Maximum Access Time	12	15	20	ns
Typical Operating Current	195	190	180	mA
Typical Standby Current for I _{SB1} (Both ports TTL level)	55	50	45	mA
Typical Standby Current for I _{SB3} (Both ports CMOS level)	0.05	0.05	0.05	mA

Note

7. This pin is NC for CY7C037.

Pin Definitions

Left Port	Right Port	Description
$\overline{CE}_{0L}, CE_{1L}$	$\overline{CE}_{0R}, CE_{1R}$	Chip Enable (\overline{CE} is LOW when $\overline{CE}_0 \leq V_{IL}$ and $CE_1 \geq V_{IH}$)
R/\overline{W}_L	R/\overline{W}_R	Read/Write Enable
\overline{OE}_L	\overline{OE}_R	Output Enable
$A_{0L}-A_{15L}$	$A_{0R}-A_{15R}$	Address (A_0-A_{14} for 32K; A_0-A_{15} for 64K devices)
$I/O_{0L}-I/O_{17L}$	$I/O_{0R}-I/O_{17R}$	Data Bus Input/Output ($I/O_0-I/O_{15}$ for x16 devices; $I/O_0-I/O_{17}$ for x18)
\overline{SEM}_L	\overline{SEM}_R	Semaphore Enable
\overline{UB}_L	\overline{UB}_R	Upper Byte Select ($I/O_8-I/O_{15}$ for x16 devices; $I/O_9-I/O_{17}$ for x18 devices)
\overline{LB}_L	\overline{LB}_R	Lower Byte Select ($I/O_0-I/O_7$ for x16 devices; $I/O_0-I/O_8$ for x18 devices)
\overline{INT}_L	\overline{INT}_R	Interrupt Flag
\overline{BUSY}_L	\overline{BUSY}_R	Busy Flag
M/\overline{S}		Master or Slave Select
V_{CC}		Power
GND		Ground
NC		No Connect

Maximum Ratings^[8]

Exceeding maximum ratings may shorten the useful life of the device. User guidelines are not tested.

Storage Temperature	-65°C to +150°C
Ambient Temperature with Power Applied	-55°C to +125°C
Supply Voltage to Ground Potential.....	-0.3V to +7.0V
DC Voltage Applied to Outputs in High Z State	-0.5V to +7.0DC

Input Voltage ^[9]	-0.5V to +7.0V
Output Current into Outputs (LOW).....	20 mA
Static Discharge Voltage.....	>1100V
Latch-Up Current.....	>200 mA

Operating Range

Range	Ambient Temperature	V _{CC}
Commercial	0°C to +70°C	5V ± 10%
Industrial ^[10]	-40°C to +85°C	5V ± 10%

Electrical Characteristics Over the Operating Range

Symbol	Parameter	CY7C027/028 CY7C037/038									Unit
		-12 ^[1]			-15			-20			
		Min	Typ	Max	Min	Typ	Max	Min	Typ	Max	
V _{OH}	Output HIGH Voltage (V _{CC} = Min, I _{OH} = -4.0 mA)	2.4			2.4			2.4			V
V _{OL}	Output LOW Voltage (V _{CC} = Min, I _{OH} = +4.0 mA)			0.4			0.4			0.4	V
V _{IH}	Input HIGH Voltage	2.2			2.2			2.2			V
V _{IL}	Input LOW Voltage			0.8			0.8			0.8	V
I _{OZ}	Output Leakage Current	-10		10	-10		10	-10		10	μA
I _{CC}	Operating Current (V _{CC} =Max, I _{OUT} =0 mA) Outputs Disabled	Com'l.	195	325		190	280		180	265	mA
		Ind. ^[10]							305	290	mA
I _{SB1}	Standby Current (Both Ports TTL Level) CE _L & CE _R ≥ V _{IH} , f = f _{MAX}	Com'l.	55	75		50	70		45	65	mA
		Ind. ^[10]							60	80	mA
I _{SB2}	Standby Current (One Port TTL Level) CE _L CE _R ≥ V _{IH} , f = f _{MAX}	Com'l.	125	205		120	180		110	160	mA
		Ind. ^[10]							125	175	mA
I _{SB3}	Standby Current (Both Ports CMOS Level) CE _L & CE _R ≥ V _{CC} - 0.2V, f = 0	Com'l.	0.05	0.5		0.05	0.5		0.05	0.5	mA
		Ind. ^[10]							0.05	0.5	mA
I _{SB4}	Standby Current (One Port CMOS Level) CE _L CE _R ≥ V _{IH} , f = f _{MAX} ^[11]	Com'l.	115	185		110	160		100	140	mA
		Ind. ^[10]							115	155	mA

Notes

- 8. The voltage on any input or I/O pin cannot exceed the power pin during power up.
- 9. Pulse width < 20 ns.
- 10. Industrial parts are available in CY7C028 and CY7C038 only.
- 11. f_{MAX} = 1/t_{RC} = All inputs cycling at f = 1/t_{RC} (except output enable). f = 0 means no address or control lines change. This applies only to inputs at CMOS level standby I_{SB3}.

Capacitance^[12]

Parameter	Description	Test Conditions	Max	Unit
C_{IN}	Input Capacitance	$T_A = 25^\circ\text{C}$, $f = 1\text{ MHz}$, $V_{CC} = 5.0\text{V}$	10	pF
C_{OUT}	Output Capacitance		10	pF

Figure 3. AC Test Loads and Waveforms

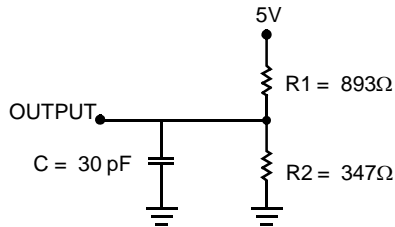

(a) Normal Load (Load 1)

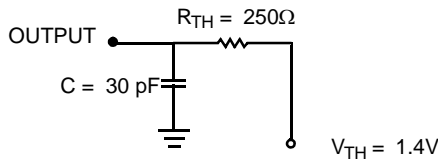

(b) Thévenin Equivalent (Load 1)

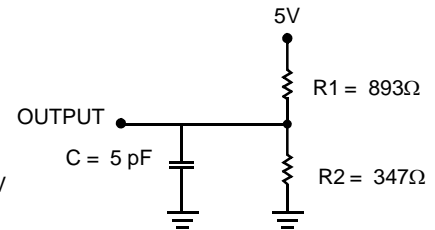

(c) Three-State Delay (Load 2)
(Used for t_{CKLZ} , t_{OLZ} , & t_{OHZ} including scope and jig)

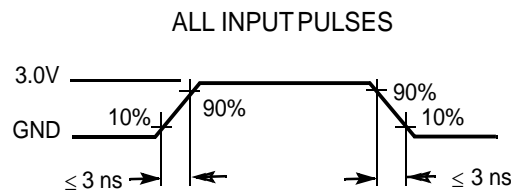

AC Test Loads (Applicable to -12 only)^[13]

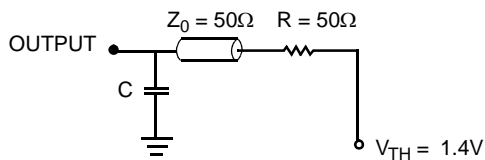

(a) Load 1 (-12 only)

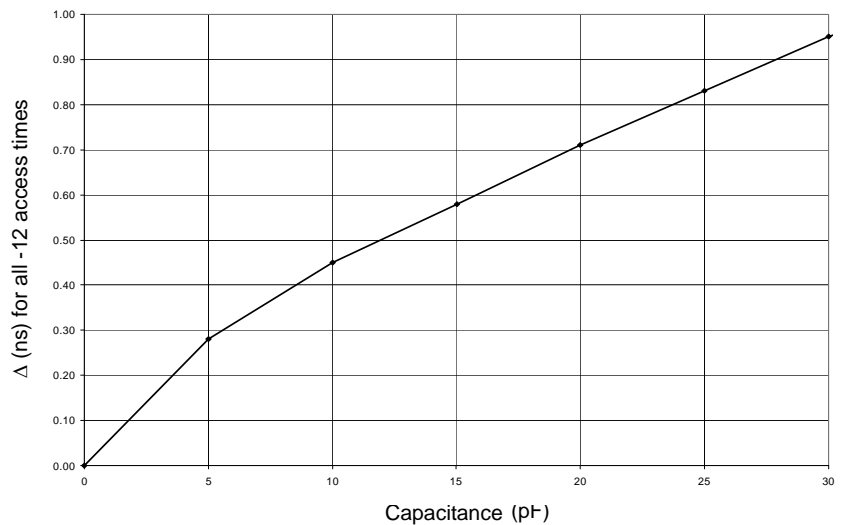

(b) Load Derating Curve

Notes

- 12. Tested initially and after any design or process changes that may affect these parameters.
- 13. Test conditions: $C = 0\text{ pF}$.

Switching Characteristics Over the Operating Range^[14]

Parameter	Description	CY7C027/028 CY7C037/038						Unit
		-12 ^[1]		-15		-20		
		Min	Max	Min	Max	Min	Max	
Read Cycle								
t _{RC}	Read Cycle Time	12		15		20		ns
t _{AA}	Address to Data Valid		12		15		20	ns
t _{OHA}	Output Hold From Address Change	3		3		3		ns
t _{ACE} ^[15]	CE LOW to Data Valid		12		15		20	ns
t _{DOE}	OE LOW to Data Valid		8		10		12	ns
t _{LZOE} ^[16, 17, 18]	OE LOW to Low Z	3		3		3		ns
t _{HZOE} ^[16, 17, 18]	OE HIGH to High Z		10		10		12	ns
t _{LZCE} ^[16, 17, 18]	CE LOW to Low Z	3		3		3		ns
t _{HZCE} ^[16, 17, 18]	CE HIGH to High Z		10		10		12	ns
t _{PU} ^[18]	CE LOW to Power Up	0		0		0		ns
t _{PD} ^[18]	CE HIGH to Power Down		12		15		20	ns
t _{ABE} ^[15]	Byte Enable Access Time		12		15		20	ns
Write Cycle								
t _{WC}	Write Cycle Time	12		15		20		ns
t _{SCE} ^[15]	CE LOW to Write End	10		12		15		ns
t _{AW}	Address Valid to Write End	10		12		15		ns
t _{HA}	Address Hold From Write End	0		0		0		ns
t _{SA} ^[15]	Address Setup to Write Start	0		0		0		ns
t _{PWE}	Write Pulse Width	10		12		15		ns
t _{SD}	Data Setup to Write End	10		10		15		ns
t _{HD}	Data Hold From Write End	0		0		0		ns
t _{HZWE} ^[17, 18]	R/W LOW to High Z		10		10		12	ns
t _{LZWE} ^[17, 18]	R/W HIGH to Low Z	3		3		3		ns
t _{WDD} ^[19]	Write Pulse to Data Delay		25		30		45	ns
t _{DDD} ^[19]	Write Data Valid to Read Data Valid		20		25		30	ns
Busy Timing ^[20]								
t _{BLA}	BUSY LOW from Address Match		12		15		20	ns
t _{BHA}	BUSY HIGH from Address Mismatch		12		15		20	ns
t _{BLC}	BUSY LOW from CE LOW		12		15		20	ns
t _{BHC}	BUSY HIGH from CE HIGH		12		15		17	ns
t _{PS}	Port Setup for Priority	5		5		5		ns
t _{WB}	R/W HIGH after BUSY (Slave)	0		0		0		ns
t _{WH}	R/W HIGH after BUSY HIGH (Slave)	11		13		15		ns
t _{BDD} ^[21]	BUSY HIGH to Data Valid		12		15		20	ns

Notes

14. Test conditions assume signal transition time of 3 ns or less, timing reference levels of 1.5V, input pulse levels of 0 to 3.0V, and output loading of the specified I_O/I_{OH} and 30 pF load capacitance.
15. To access RAM, $\overline{CE}=L, \overline{UB}=L, \overline{SEM}=H$. To access semaphore, $\overline{CE}=H$ and $\overline{SEM}=L$. Either condition must be valid for the entire t_{SCE} time.
16. At any given temperature and voltage condition for any given device, t_{HZCE} is less than t_{LZCE} and t_{HZOE} is less than t_{LZOE}.
17. Test conditions used are Load 2.
18. This parameter is guaranteed by design, but it is not production tested.
19. For information on port-to-port delay through RAM cells from writing port to reading port, refer to Figure 11.
20. Test conditions used are Load 1.

Switching Characteristics Over the Operating Range^[14] (continued)

Parameter	Description	CY7C027/028 CY7C037/038						Unit
		-12 ^[1]		-15		-20		
		Min	Max	Min	Max	Min	Max	
INTERRUPT TIMING^[20]								
t _{INS}	INT Set Time		12		15		20	ns
t _{INR}	INT Reset Time		12		15		20	ns
SEMAPHORE TIMING								
t _{SOP}	SEM Flag Update Pulse (OE or SEM)	10		10		10		ns
t _{SWRD}	SEM Flag Write to Read Time	5		5		5		ns
t _{SPS}	SEM Flag Contention Window	5		5		5		ns
t _{SAA}	SEM Address Access Time		12		15		20	ns

Data Retention Mode

The CY7C027/028 and CY7C037/038 are designed with battery backup in mind. Data retention voltage and supply current are guaranteed over temperature. The following rules ensure data retention:

1. Chip enable (\overline{CE}) must be held HIGH during data retention, within V_{CC} to $V_{CC} - 0.2V$.
2. \overline{CE} must be kept between $V_{CC} - 0.2V$ and 70% of V_{CC} during the power up and power down transitions.
3. The RAM can begin operation $>t_{RC}$ after V_{CC} reaches the minimum operating voltage (4.5V).

Timing

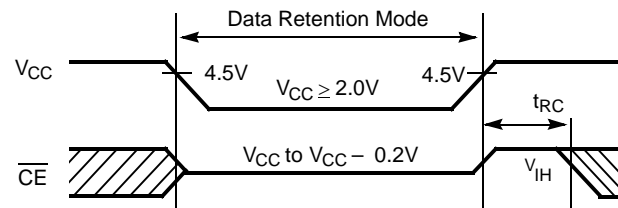

Parameter	Test Conditions ^[22]	Max	Unit
ICC _{DR1}	At V _{CCDR} = 2V	1.5	mA

Notes

21. t_{BDD} is a calculated parameter and is the greater of t_{WDD}-t_{PWE} (actual) or t_{BDD}-t_{SD} (actual).
22. CE = V_{CC}, V_{in} = GND to V_{CC}, T_A = 25°C. This parameter is guaranteed but not tested.

Switching Waveforms

Figure 4. Read Cycle No. 1 (Either Port Address Access)^[23, 24, 25]

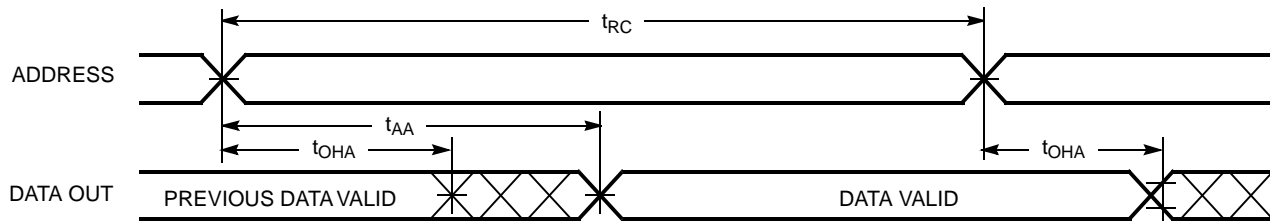

Figure 5. Read Cycle No. 2 (Either Port $\overline{\text{CE}}/\overline{\text{OE}}$ Access)^[23, 26, 27]

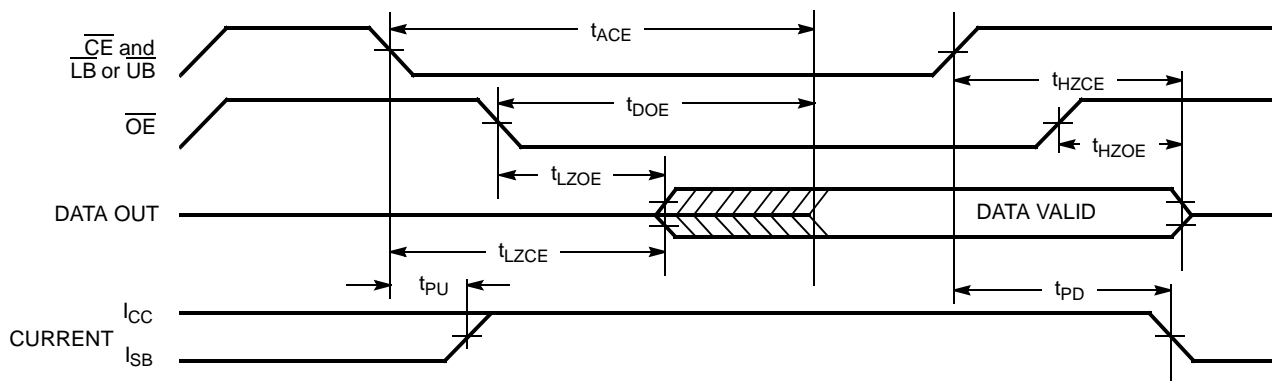
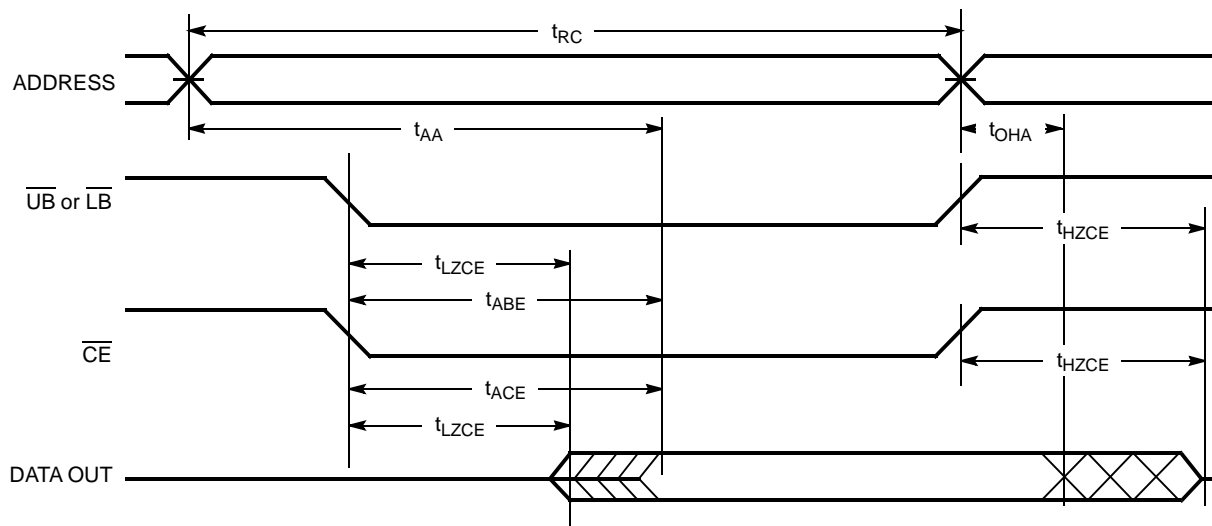

Figure 6. Read Cycle No. 3 (Either Port)^[23, 25, 26, 27]



Notes

23. R/W is HIGH for read cycles.
24. Device is continuously selected $\overline{\text{CE}} = V_{\text{IL}}$ and $\overline{\text{UB}}$ or $\overline{\text{LB}} = V_{\text{IL}}$. This waveform cannot be used for semaphore reads.
25. $\text{OE} = V_{\text{IL}}$.
26. Address valid prior to or coincident with $\overline{\text{CE}}$ transition LOW.
27. To access RAM, $\text{CE} = V_{\text{IL}}$, $\overline{\text{UB}}$ or $\overline{\text{LB}} = V_{\text{IL}}$, $\text{SEM} = V_{\text{IH}}$. To access semaphore, $\overline{\text{CE}} = V_{\text{IH}}$, $\overline{\text{SEM}} = V_{\text{IL}}$.

Switching Waveforms (continued)

Figure 7. Write Cycle No. 1: R/W Controlled Timing^[28, 29, 30, 31]

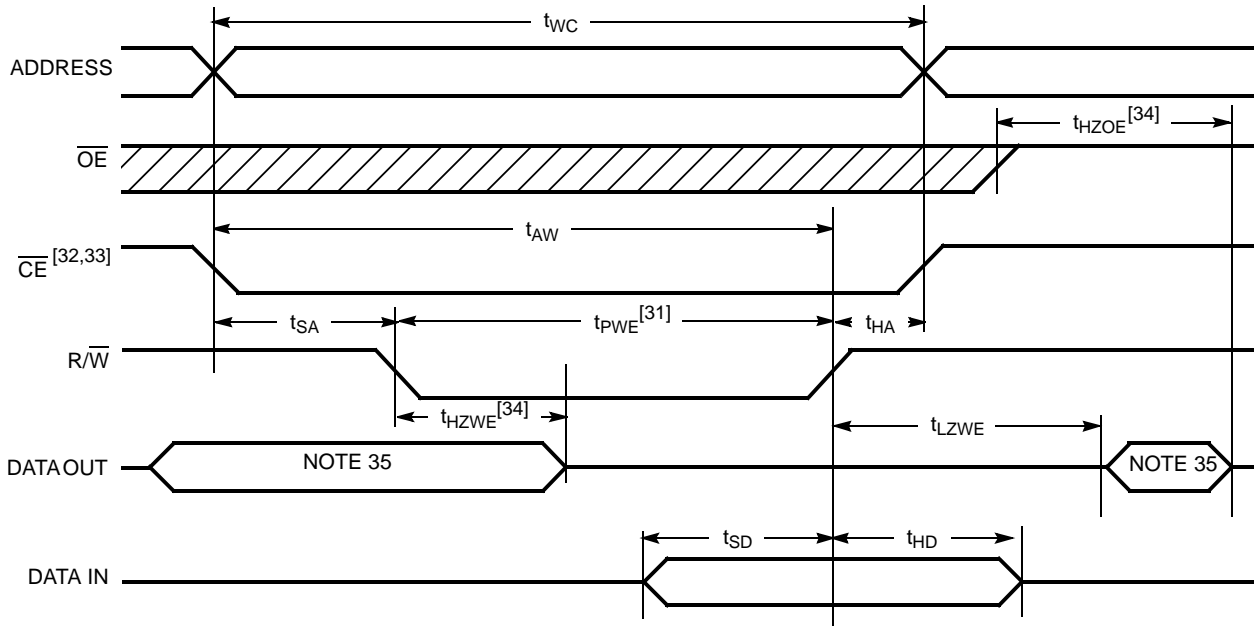
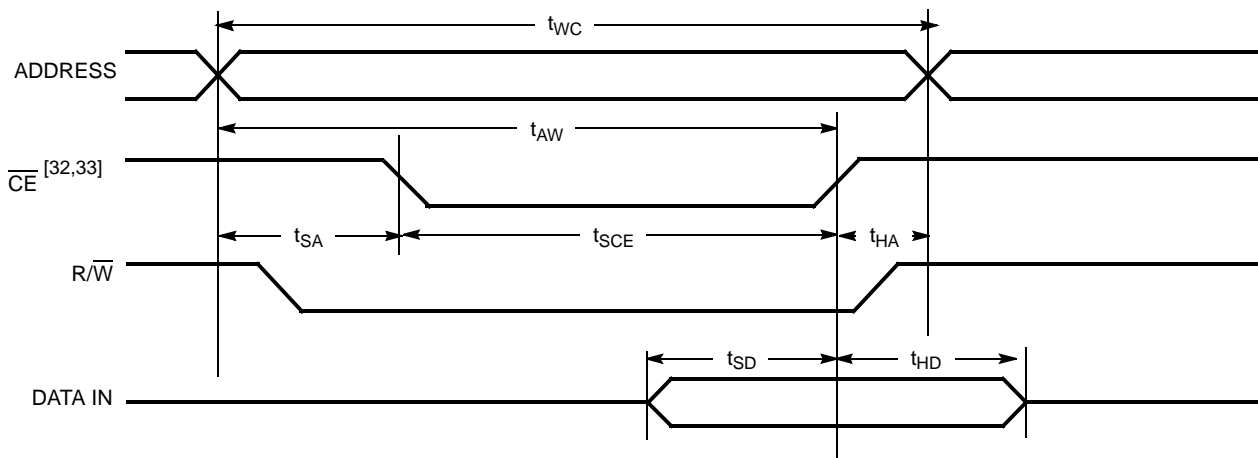

Figure 8. Write Cycle No. 2: CE Controlled Timing^[28, 29, 30, 34, 35]



Notes

28. R/W must be HIGH during all address transitions.
29. A write occurs during the overlap (t_{SCE} or t_{PWE}) of a LOW CE or SEM and a LOW UB or LB.
30. t_{HA} is measured from the earlier of CE or R/W or (SEM or R/W) going HIGH at the end of write cycle.
31. If OE is LOW during a R/W controlled write cycle, the write pulse width must be the larger of t_{PWE} or ($t_{HZWE} + t_{SD}$) to allow the I/O drivers to turn off and data to be placed on the bus for the required t_{SD} . If OE is HIGH during an R/W controlled write cycle, this requirement does not apply and the write pulse can be as short as the specified t_{PWE} .
32. To access RAM, CE = V_{IL} , SEM = V_{IH} .
33. To access upper byte, CE = V_{IL} , UB = V_{IL} , SEM = V_{IH} .
To access lower byte, CE = V_{IL} , LB = V_{IL} , SEM = V_{IH} .
34. Transition is measured ± 500 mV from steady state with a 5 pF load (including scope and jig). This parameter is sampled and not 100% tested.
35. During this period, the I/O pins are in the output state, and input signals must not be applied.
36. If the CE or SEM LOW transition occurs simultaneously with or after the R/W LOW transition, the outputs remain in the high impedance state.

Switching Waveforms (continued)

Figure 9. Semaphore Read After Write Timing, Either Side^[37]

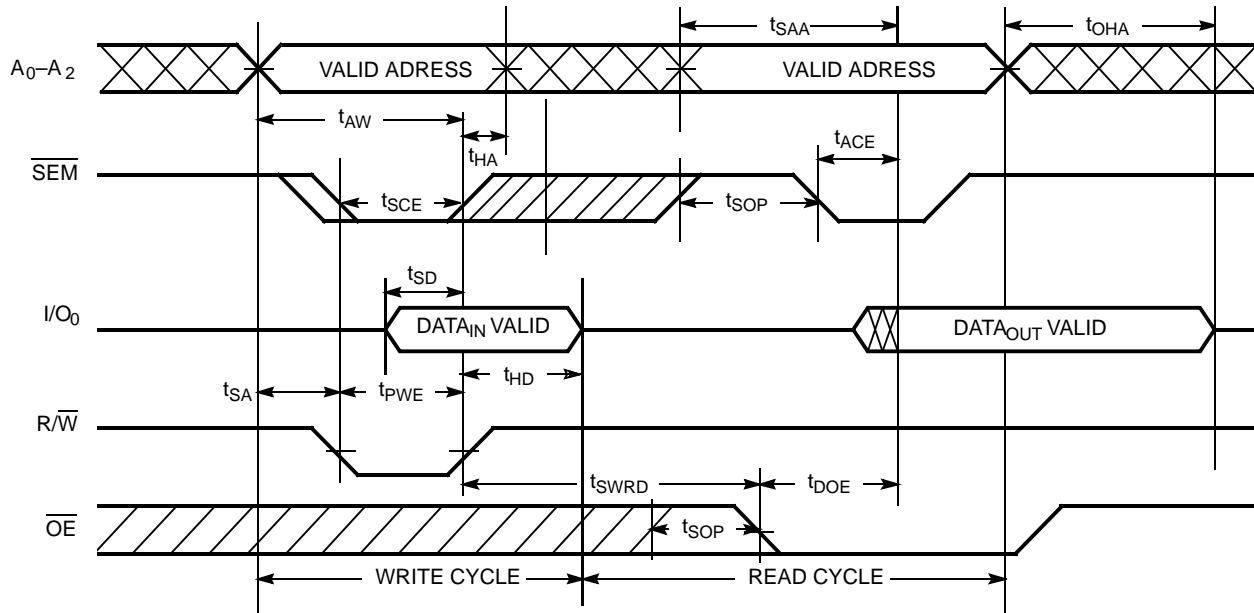
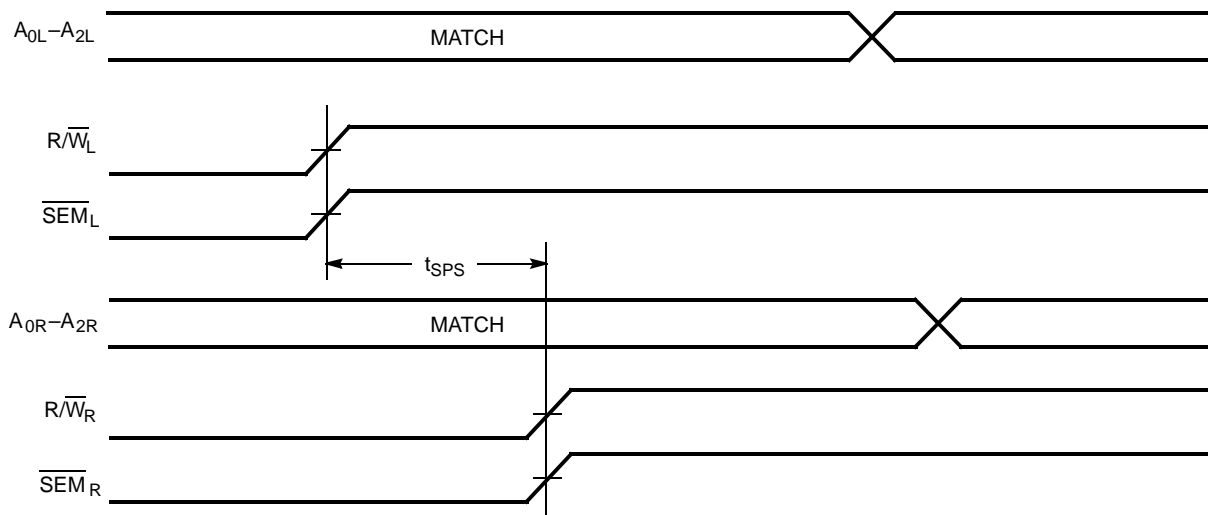

Figure 10. Timing Diagram of Semaphore Contention^[38, 39, 40]



Notes

- 37. \overline{CE} = HIGH for the duration of the above timing (both write and read cycle).
- 38. $I/O_{0R} = I/O_{0L} = \text{LOW}$ (request semaphore); $\overline{CE}_R = \overline{CE}_L = \text{HIGH}$.
- 39. Semaphores are reset (available to both ports) at cycle start.
- 40. If t_{SPS} is violated, the semaphore is definitely obtained by one side or the other, but which side gets the semaphore is unpredictable.

Switching Waveforms (continued)

Figure 11. Timing Diagram of Read with $\overline{\text{BUSY}}$ ($\overline{\text{M}}/\overline{\text{S}}=\text{HIGH}$)^[41]

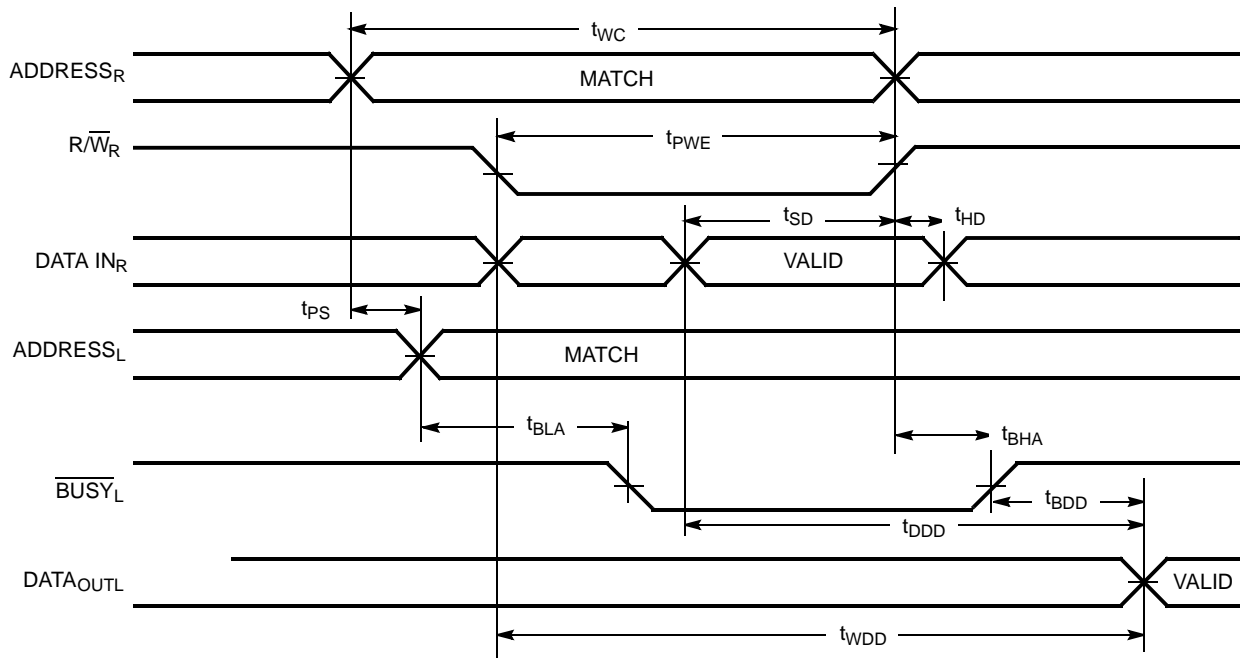
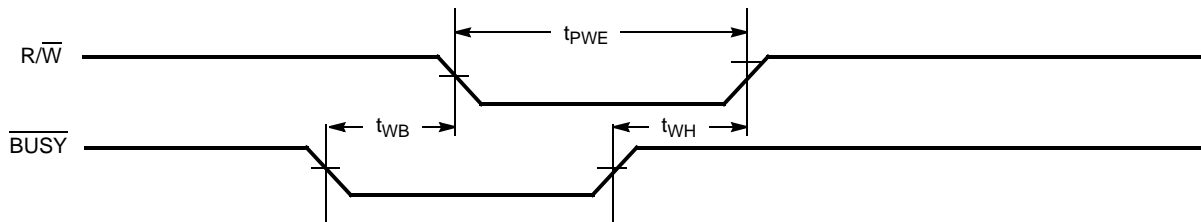

Figure 12. Write Timing with Busy Input ($\overline{\text{M}}/\overline{\text{S}}=\text{LOW}$)



Note
41. $\overline{\text{CE}}_L = \overline{\text{CE}}_R = \text{LOW}$.

Switching Waveforms (continued)

Figure 13. Busy Timing Diagram No.1 ($\overline{\text{CE}}$ Arbitration)^[42]

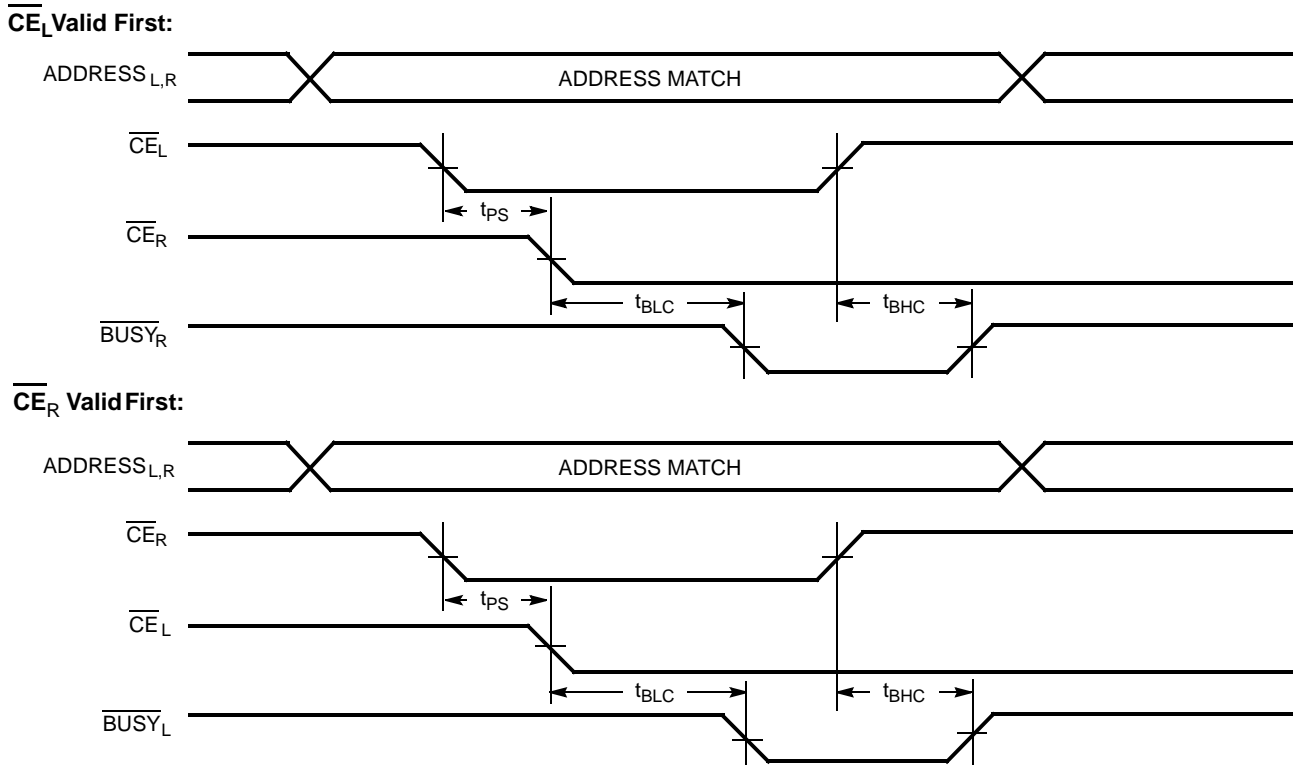
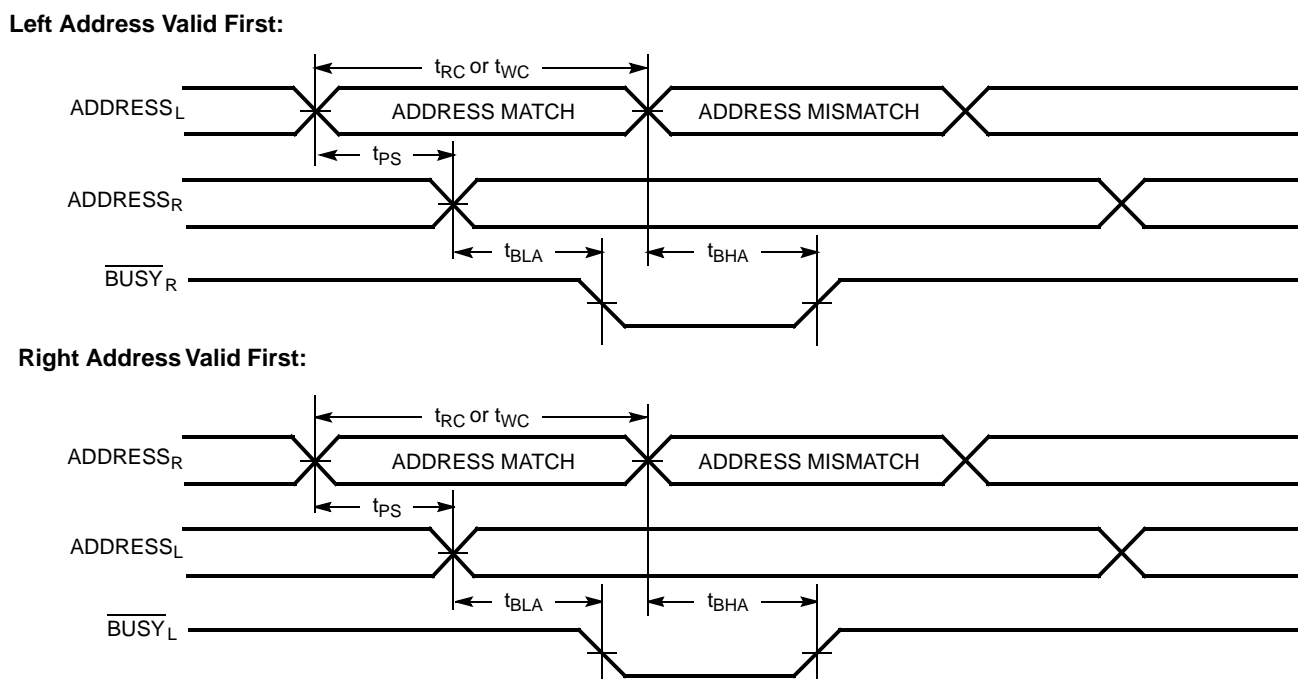

Figure 14. Busy Timing Diagram No. 2 (Address Arbitration)^[42]



Note

42. If t_{PS} is violated, the busy signal is asserted on one side or the other, but there is no guarantee to which side $\overline{\text{BUSY}}$ is asserted.

Switching Waveforms (continued)

Figure 15. Interrupt Timing Diagrams

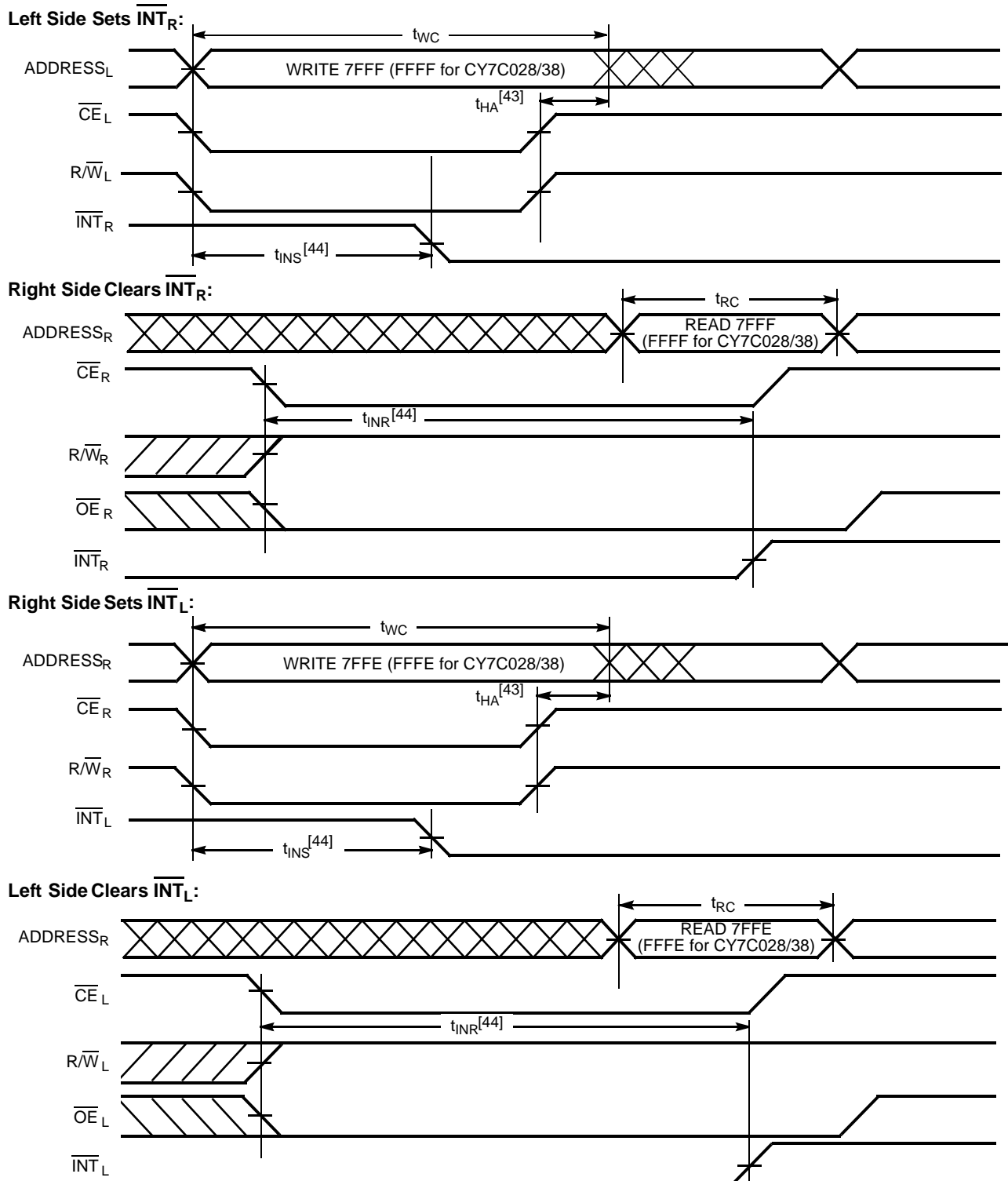

Notes

- 43. t_{HA} depends on which enable pin ($\overline{\text{CE}}_L$ or $\text{R}/\overline{\text{W}}_L$) is deasserted first.
- 44. t_{INS} or t_{INR} depends on which enable pin ($\overline{\text{CE}}_L$ or $\text{R}/\overline{\text{W}}_L$) is asserted last.

Architecture

The CY7C027/028 and CY7C037/038 consist of an array of 32K and 64K words of 16 and 18 bits each of dual-port RAM cells, I/O and address lines, and control signals (\overline{CE} , \overline{OE} , R/W). These control pins permit independent access for reads or writes to any location in memory. To handle simultaneous writes/reads to the same location, a BUSY pin is provided on each port. Two interrupt (INT) pins can be used for port-to-port communication. Two semaphore (SEM) control pins are used for allocating shared resources. With the M/S pin, the devices can function as a master (BUSY pins are outputs) or as a slave (BUSY pins are inputs). The devices also have an automatic power down feature controlled by \overline{CE} . Each port is provided with its own output enable control (\overline{OE}), which allows data to be read from the device.

Functional Description

Write Operation

Data must be set up for a duration of t_{SD} before the rising edge of R/W to guarantee a valid write. A write operation is controlled by either the R/W pin (see Figure 7) or the \overline{CE} pin (see Figure 8). Required inputs for non-contention operations are summarized in Table 1.

If a location is being written to by one port and the opposite port attempts to read that location, a port-to-port flowthrough delay must occur before the data is read on the output; otherwise the data read is not deterministic. Data is valid on the port t_{DDD} after the data is presented on the other port.

Read Operation

When reading the device, the user must assert both the \overline{OE} and \overline{CE} pins. Data is available t_{ACE} after \overline{CE} or t_{DOE} after \overline{OE} is asserted. If the user wishes to access a semaphore flag, then the SEM pin must be asserted instead of the \overline{CE} pin, and \overline{OE} must also be asserted.

Interrupts

The upper two memory locations may be used for message passing. The highest memory location (7FFF for the CY7C027/37, FFFF for the CY7C028/38) is the mailbox for the right port and the second-highest memory location (7FFE for the CY7C027/37, FFFE for the CY7C028/38) is the mailbox for the left port. When one port writes to the other port's mailbox, an interrupt is generated to the owner. The interrupt is reset when the owner reads the contents of the mailbox. The message is user defined.

Each port can read the other port's mailbox without resetting the interrupt. The active state of the busy signal (to a port) prevents the port from setting the interrupt to the winning port. Also, an active busy to a port prevents that port from reading its own mailbox and, thus, resetting the interrupt to it.

If an application does not require message passing, do not connect the interrupt pin to the processor's interrupt request input pin.

The operation of the interrupts and their interaction with Busy is summarized in Table 2.

Busy

The CY7C027/028 and CY7C037/038 provide on-chip arbitration to resolve simultaneous memory location access (contention). If both ports' \overline{CE} s are asserted and an address match occurs within t_{PS} of each other, the busy logic determines which port has access. If t_{PS} is violated, one port definitely gains permission to the location, but it is not predictable which port gets that permission. BUSY is asserted t_{BLA} after an address match or t_{BLC} after \overline{CE} is taken LOW.

Master/Slave

A M/S pin is provided to expand the word width by configuring the device as either a master or a slave. The BUSY output of the master is connected to the BUSY input of the slave. This allows the device to interface to a master device with no external components. Writing to slave devices must be delayed until after the BUSY input has settled (t_{BLC} or t_{BLA}), otherwise, the slave chip may begin a write cycle during a contention situation. When tied HIGH, the M/S pin allows the device to be used as a master and, therefore, the BUSY line is an output. BUSY can then be used to send the arbitration outcome to a slave.

Semaphore Operation

The CY7C027/028 and CY7C037/038 provide eight semaphore latches, which are separate from the dual-port memory locations. Semaphores are used to reserve resources that are shared between the two ports. The state of the semaphore indicates that a resource is in use. For example, if the left port wants to request a given resource, it sets a latch by writing a zero to a semaphore location. The left port then verifies its success in setting the latch by reading it. After writing to the semaphore, SEM or \overline{OE} must be deasserted for t_{SOP} before attempting to read the semaphore. The semaphore value is available $t_{SWRD} + t_{DOE}$ after the rising edge of the semaphore write. If the left port was successful (reads a zero), it assumes control of the shared resource, otherwise (reads a one) it assumes the right port has control and continues to poll the semaphore. When the right side has relinquished control of the semaphore (by writing a one), the left side succeeds in gaining control of the semaphore. If the left side no longer requires the semaphore, a one is written to cancel its request.

Semaphores are accessed by asserting SEM LOW. The SEM pin functions as a chip select for the semaphore latches (\overline{CE} must remain HIGH during SEM LOW). A_{0-2} represents the semaphore address. \overline{OE} and R/W are used in the same manner as a normal memory access. When writing or reading a semaphore, the other address pins have no effect.

When writing to the semaphore, only I/O₀ is used. If a zero is written to the left port of an available semaphore, a one appears at the same semaphore address on the right port. That semaphore can now only be modified by the side showing zero (the left port in this case). If the left port now relinquishes control by writing a one to the semaphore, the semaphore is set to one for both sides. However, if the right port had requested the semaphore (written a zero) while the left port had control, the right port would immediately own the semaphore as soon as the left port released it. Table 3 shows sample semaphore operations.

When reading a semaphore, all sixteen/eighteen data lines output the semaphore value. The read value is latched in an

output register to prevent the semaphore from changing state during a write from the other port. If both ports attempt to access the semaphore within t_{SPS} of each other, the semaphore is

definitely obtained by one side or the other, but there is no guarantee which side controls the semaphore.

Table 1. Non-Contending Read/Write



Inputs						Outputs		Operation
CE	R/W	OE	UB	LB	SEM	I/O ₉ -I/O ₁₇	I/O ₀ -I/O ₈	
H	X	X	X	X	H	High Z	High Z	Deselected: Power Down
X	X	X	H	H	H	High Z	High Z	Deselected: Power Down
L	L	X	L	H	H	Data In	High Z	Write to Upper Byte Only
L	L	X	H	L	H	High Z	Data In	Write to Lower Byte Only
L	L	X	L	L	H	Data In	Data In	Write to Both Bytes
L	H	L	L	H	H	Data Out	High Z	Read Upper Byte Only
L	H	L	H	L	H	High Z	Data Out	Read Lower Byte Only
L	H	L	L	L	H	Data Out	Data Out	Read Both Bytes
X	X	H	X	X	X	High Z	High Z	Outputs Disabled
H	H	L	X	X	L	Data Out	Data Out	Read Data in Semaphore Flag
X	H	L	H	H	L	Data Out	Data Out	Read Data in Semaphore Flag
H		X	X	X	L	Data In	Data In	Write D _{IN0} into Semaphore Flag
X		X	H	H	L	Data In	Data In	Write D _{IN0} into Semaphore Flag
L	X	X	L	X	L			Not Allowed
L	X	X	X	L	L			Not Allowed

Table 2. Interrupt Operation Example (assumes $\overline{BUSY}_L = \overline{BUSY}_R = \text{HIGH}$)^[23]

Function	Left Port					Right Port				
	R/W _L	CE _L	OE _L	A _{0L-14L}	INT _L	R/W _R	CE _R	OE _R	A _{0R-14R}	INT _R
Set Right INT _R Flag	L	L	X	7FFF	X	X	X	X	X	L ^[25]
Reset Right INT _R Flag	X	X	X	X	X	X	L	L	7FFF	H ^[24]
Set Left INT _L Flag	X	X	X	X	L ^[24]	L	L	X	7FFE	X
Reset Left INT _L Flag	X	L	L	7FFE	H ^[25]	X	X	X	X	X

Table 3. Semaphore Operation Example

Function	I/O ₀ -I/O ₁₇ Left	I/O ₀ -I/O ₁₇ Right	Status
No action	1	1	Semaphore free
Left port writes 0 to semaphore	0	1	Left port has semaphore token
Right port writes 0 to semaphore	0	1	No change. Right side has no write access to semaphore
Left port writes 1 to semaphore	1	0	Right port obtains semaphore token
Left port writes 0 to semaphore	1	0	No change. Left port has no write access to semaphore
Right port writes 1 to semaphore	0	1	Left port obtains semaphore token
Left port writes 1 to semaphore	1	1	Semaphore free
Right port writes 0 to semaphore	1	0	Right port has semaphore token
Right port writes 1 to semaphore	1	1	Semaphore free
Left port writes 0 to semaphore	0	1	Left port has semaphore token
Left port writes 1 to semaphore	1	1	Semaphore free

Notes

23. A_{0L-15L} and A_{0R-15R}, FFFF/FFFE for the CY7C028/038.

24. If $\overline{BUSY}_R = L$, then no change.

25. If $\overline{BUSY}_L = L$, then no change.

Ordering Information

32K x16 Asynchronous Dual-Port SRAM

Speed (ns)	Ordering Code	Package Name	Package Type	Operating Range
12 ^[1]	CY7C027-12AC	A100	100-Pin Thin Quad Flat Pack	Commercial
15	CY7C027-15AC	A100	100-Pin Thin Quad Flat Pack	Commercial
	CY7C027-15AXI	A100	100-Pin Pb-Free Thin Quad Flat Pack	Industrial
20	CY7C027-20AC	A100	100-Pin Thin Quad Flat Pack	Commercial
	CY7C027-20AXC	A100	100-Pin Pb-Free Thin Quad Flat Pack	Commercial

64K x16 Asynchronous Dual-Port SRAM

Speed (ns)	Ordering Code	Package Name	Package Type	Operating Range
12 ^[1]	CY7C028-12AC	A100	100-Pin Thin Quad Flat Pack	Commercial
	CY7C028-12AXC	A100	100-Pin Pb-Free Thin Quad Flat Pack	Commercial
15	CY7C028-15AC	A100	100-Pin Thin Quad Flat Pack	Commercial
	CY7C028-15AXC	A100	100-Pin Pb-Free Thin Quad Flat Pack	Commercial
	CY7C028-15AI	A100	100-Pin Thin Quad Flat Pack	Industrial
	CY7C028-15AXI	A100	100-Pin Pb-Free Thin Quad Flat Pack	Industrial
20	CY7C028-20AC	A100	100-Pin Thin Quad Flat Pack	Commercial
	CY7C028-20AI	A100	100-Pin Thin Quad Flat Pack	Industrial

32K x18 Asynchronous Dual-Port SRAM

Speed (ns)	Ordering Code	Package Name	Package Type	Operating Range
12 ^[1]	CY7C037-12AC	A100	100-Pin Thin Quad Flat Pack	Commercial
15	CY7C037-15AC	A100	100-Pin Thin Quad Flat Pack	Commercial
20	CY7C037-20AC	A100	100-Pin Thin Quad Flat Pack	Commercial

64K x18 Asynchronous Dual-Port SRAM

Speed (ns)	Ordering Code	Package Name	Package Type	Operating Range
12 ^[1]	CY7C038-12AC	A100	100-Pin Thin Quad Flat Pack	Commercial
15	CY7C038-15AC	A100	100-Pin Thin Quad Flat Pack	Commercial
20	CY7C038-20AC	A100	100-Pin Thin Quad Flat Pack	Commercial
	CY7C038-20AI	A100	100-Pin Thin Quad Flat Pack	Industrial

Package Diagram

Figure 16. 100-Pin Pb-Free Thin Plastic Quad Flat Pack (TQFP) A100

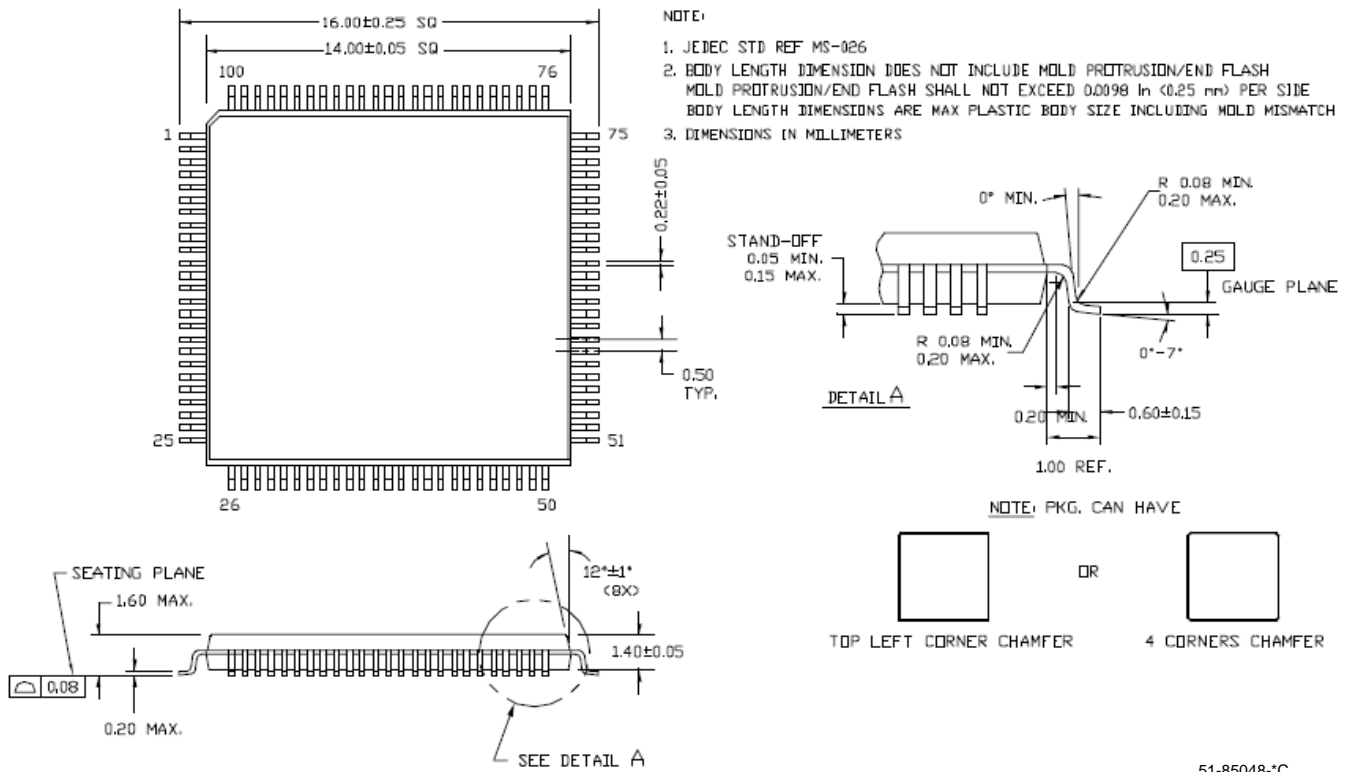

51-85048-C

Document History Page

Document Title: CY7C027/028, CY7C037/038 32K/64K x 16/18 Dual-Port Static RAM				
Document Number: 38-06042				
Rev.	ECN No.	Orig. of Change	Submission Date	Description of Change
**	110190	SZV	09/29/01	Change from Spec number: 38-00666 to 38-06042
*A	122292	RBI	12/27/02	Power up requirements added to Maximum Ratings Information
*B	236765	YDT	6/23/04	Removed cross information from features section
*C	377454	PCX	See ECN	Added Pb-Free Logo Added Pb-Free parts to ordering information: CY7C027-20AXC, CY7C028-12AXC, CY7C028-15AXC, CY7C028-15AI, CY7C028-15AXI
*D	2623540	VKN/PYRS	12/17/08	Added CY7C027-15AXI in the Ordering information table

Sales, Solutions, and Legal Information

Worldwide Sales and Design Support

Cypress maintains a worldwide network of offices, solution centers, manufacturer's representatives, and distributors. To find the office closest to you, visit us at cypress.com/sales.

Products

PSoC	psoc.cypress.com
Clocks & Buffers	clocks.cypress.com
Wireless	wireless.cypress.com
Memories	memory.cypress.com
Image Sensors	image.cypress.com

PSoC Solutions

General	psoc.cypress.com/solutions
Low Power/Low Voltage	psoc.cypress.com/low-power
Precision Analog	psoc.cypress.com/precision-analog
LCD Drive	psoc.cypress.com/lcd-drive
CAN 2.0b	psoc.cypress.com/can
USB	psoc.cypress.com/usb

© Cypress Semiconductor Corporation, 2001-2008. The information contained herein is subject to change without notice. Cypress Semiconductor Corporation assumes no responsibility for the use of any circuitry other than circuitry embodied in a Cypress product. Nor does it convey or imply any license under patent or other rights. Cypress products are not warranted nor intended to be used for medical, life support, life saving, critical control or safety applications, unless pursuant to an express written agreement with Cypress. Furthermore, Cypress does not authorize its products for use as critical components in life-support systems where a malfunction or failure may reasonably be expected to result in significant injury to the user. The inclusion of Cypress products in life-support systems application implies that the manufacturer assumes all risk of such use and in doing so indemnifies Cypress against all charges.

Any Source Code (software and/or firmware) is owned by Cypress Semiconductor Corporation (Cypress) and is protected by and subject to worldwide patent protection (United States and foreign), United States copyright laws and international treaty provisions. Cypress hereby grants to licensee a personal, non-exclusive, non-transferable license to copy, use, modify, create derivative works of, and compile the Cypress Source Code and derivative works for the sole purpose of creating custom software and or firmware in support of licensee product to be used only in conjunction with a Cypress integrated circuit as specified in the applicable agreement. Any reproduction, modification, translation, compilation, or representation of this Source Code except as specified above is prohibited without the express written permission of Cypress.

Disclaimer: CYPRESS MAKES NO WARRANTY OF ANY KIND, EXPRESS OR IMPLIED, WITH REGARD TO THIS MATERIAL, INCLUDING, BUT NOT LIMITED TO, THE IMPLIED WARRANTIES OF MERCHANTABILITY AND FITNESS FOR A PARTICULAR PURPOSE. Cypress reserves the right to make changes without further notice to the materials described herein. Cypress does not assume any liability arising out of the application or use of any product or circuit described herein. Cypress does not authorize its products for use as critical components in life-support systems where a malfunction or failure may reasonably be expected to result in significant injury to the user. The inclusion of Cypress' product in a life-support systems application implies that the manufacturer assumes all risk of such use and in doing so indemnifies Cypress against all charges.

Use may be limited by and subject to the applicable Cypress software license agreement.







Looking for pricing, stock, or lifecycle information?

Click below to explore more details on WIN SOURCE:

 [View CY7C038V-20AI on WIN SOURCE](#)

 [Infineon Technologies](#) Information

Optimize Your Supply Chain with WIN SOURCE Solutions

-  Global Sourcing Solution
-  Obsolete Management
-  Cost Control Management
-  Shortage Management
-  Alternative Solution
-  Excess Inventory Management