



THE DATASHEET OF AMC7832IPAPR



AMC7832 12-Bit Analog Monitor and Control Solution with Multi-Channel ADC, Bipolar DACs, Temperature Sensor and GPIO Ports

1 Features

- Twelve Monotonic 12-Bit DACs
 - Selectable Ranges: 0 to +5-V, 0 to +10-V and -10 to 0-V
 - High Current Drive Capability: up to ± 15 -mA
 - Selectable Clamp Voltage
- One 12-Bit SAR ADC
 - 17 External Analog Inputs
 - 12 Bipolar Inputs: -12.5-V to +12.5-V Range
 - 5 High Precision Inputs: 0 to +5-V Range
 - Programmable Out-of-Range Alarms
- Internal +2.5-V Reference
- Internal Temperature Sensor
 - -40°C to +125°C Operation
 - ± 2.5 °C Accuracy
- Eight General Purpose I/O Ports (GPIOs)
- Low Power SPI Compatible Serial Interface
 - 4-Wire Mode, +1.8-V to +5.5-V Operation
- Operating Temperature Range: -40°C to +125°C
- Available in 64-Terminal HTQFP PowerPAD Package

2 Applications

- Communications Infrastructure:
 - Cellular Base Stations
 - Microwave Backhaul
 - Optical Networks
- General Purpose Monitor & Control
- Data Acquisition Systems

4 Power Amp Biasing Diagram

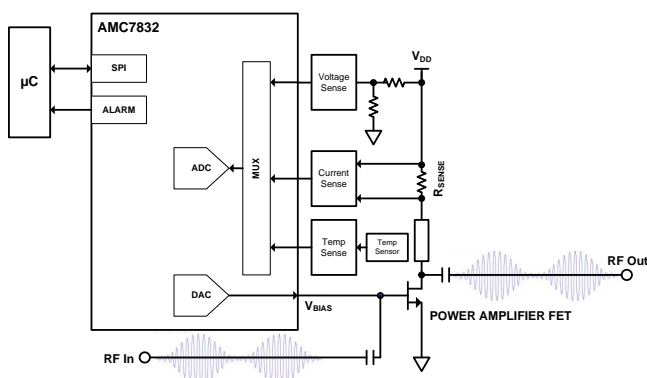

3 Description

The AMC7832 is a highly integrated, low-power, analog monitoring and control solution that includes a 17-channel, 12-bit analog-to-digital converter (ADC) with programmable alarms, twelve 12-bit digital-to-analog converters (DACs) with output ranges of either 0 to +5-V, 0 to +10-V or -10 to 0-V, eight GPIOs, internal reference and a local temperature sensor channel. The AMC7832 high level of integration significantly reduces component count and simplifies closed-loop system designs.

The AMC7832 is ideal for multichannel applications where board space, size, and low power are critical.

The AMC7832's low power, high-integration and wide operating temperature range make it an ideal all-in-one, low-cost, bias control circuit for the power amplifiers (PA) found in multi-channel RF communication systems. The flexible DAC output ranges allow the device to be used as a biasing solution for a large variety of transistor technologies such as LDMOS, GaAs and GaN. The AMC7832 feature set is similarly beneficial in general purpose monitor and control systems.

For applications that require a different channel count, additional features, or converter resolutions, Texas Instruments offers a complete family of Analog Monitor and Control (AMC) products. Visit <http://www.ti.com/amc> for more information.

Device Information

ORDER NUMBER	PACKAGE	BODY SIZE
AMC7832IPAP	HTQFP (64)	10mm x 10mm

Functional Diagram

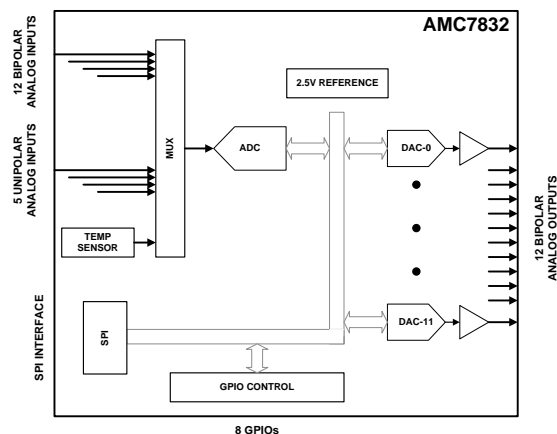

Table of Contents

1 Features	1	8.1 Overview	23
2 Applications	1	8.2 Functional Block Diagram	24
3 Description	1	8.3 Feature Description	25
4 Power Amp Biasing Diagram	1	8.4 Programming	39
5 Revision History	2	8.5 Register Map	41
6 Terminal Configuration and Functions	3	9 Applications and Implementation	54
7 Specifications	6	9.1 Application Information	54
7.1 Absolute Maximum Ratings	6	9.2 Typical Application	54
7.2 Handling Ratings	6	10 Power Supply Recommendations	59
7.3 Recommended Operating Conditions	7	11 Layout	60
7.4 Thermal Information	7	11.1 Layout Guidelines	60
7.5 Electrical Characteristics	8	11.2 Layout Example	60
7.6 Timing Requirements - Serial Interface	13	12 Device and Documentation Support	64
7.7 Typical Characteristics: DAC	15	12.1 Trademarks	64
7.8 Typical Characteristics: ADC	20	12.2 Electrostatic Discharge Caution	64
7.9 Typical Characteristics: Reference	22	12.3 Glossary	64
7.10 Typical Characteristics: Temperature Sensor	22	13 Mechanical, Packaging, and Orderable Information	64
8 Detailed Description	23		

5 Revision History

DATE	REVISION	NOTES
March	*	Initial release.

6 Terminal Configuration and Functions

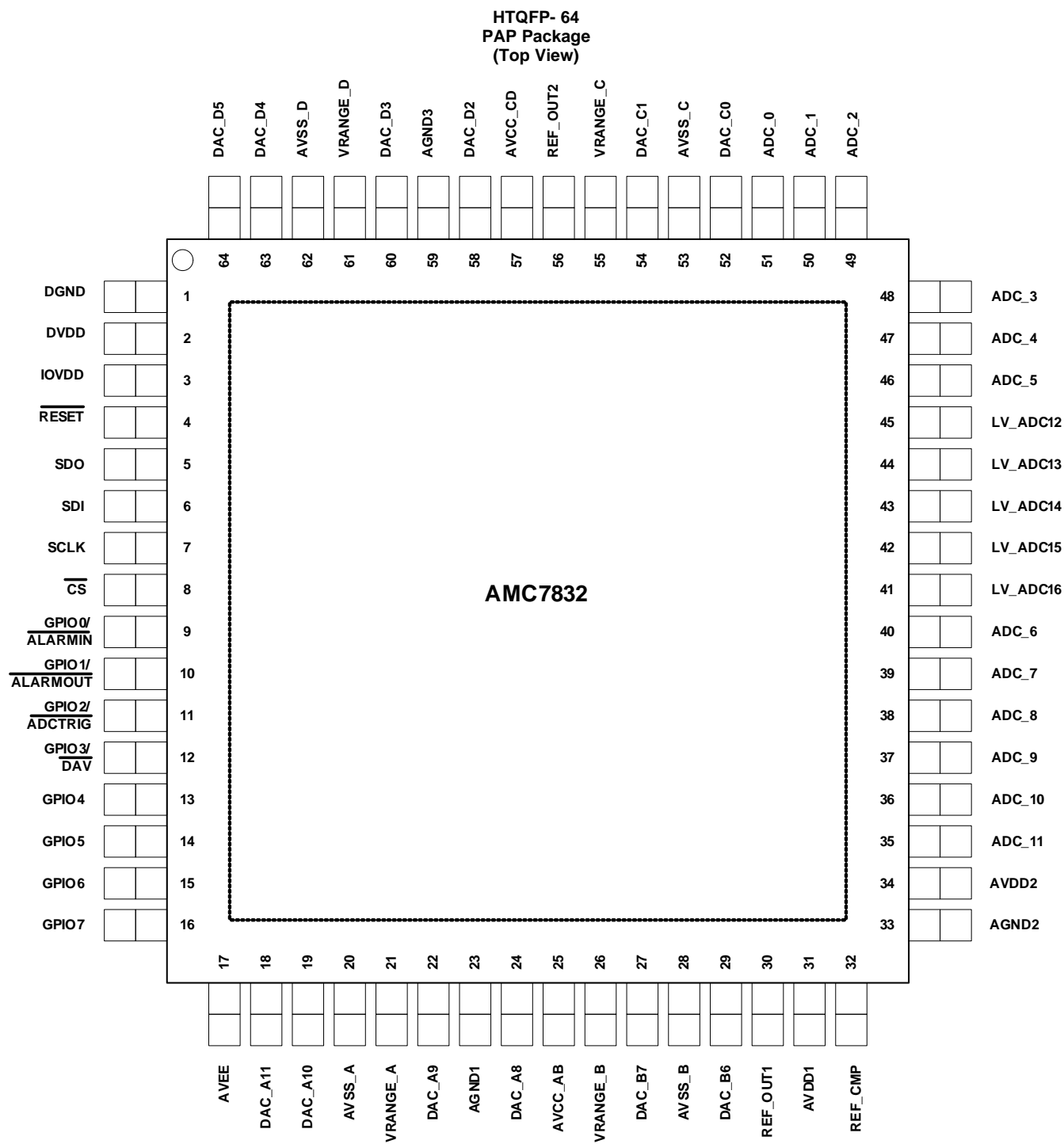

Terminal Functions

TERMINAL		DESCRIPTION
NUMBER	NAME	
1	DGND	Digital ground. Ground reference point for all digital circuitry on the device. Ideally, AGND and DGND should be at the same potential (GND) and must not differ by more than ± 0.3 -V.
2	DV _{DD}	Digital supply voltage. (+4.5-V to +5.5-V). Must be the same value as AV _{DD} .
3	IOV _{DD}	IO supply voltage. (+1.8-V to +5.5-V). Sets the IO operating voltage and threshold levels. Must not exceed DV _{DD} .
4	RESET	Reset input, active low. Logic low on this terminal causes the device to perform a hardware reset.
5	SDO	Serial interface data output. The SDO terminal is in high impedance when CS is high. Data is clocked out of the input shift register on each falling edge of SCLK.
6	SDI	Serial interface data input. Data is clocked into the input shift register on each rising edge of SCLK.
7	SCLK	Serial interface clock.
8	CS	Active low serial data enable. This input is the frame synchronization signal for the serial data. When this signal goes low, it enables the input shift register.
9	GPIO0/ALARMIN	General purpose digital I/O 0 (default). This terminal is a bidirectional open-drain, digital input/output with internal 48-k Ω pull-up resistor to IOV _{DD} . Alternatively the terminal can be set to operate as ALARMIN, an alarm control signal, digital input, active low.
10	GPIO1/ALARMOUT	General purpose digital I/O 1 (default). This terminal is a bidirectional open-drain, digital input/output with internal 48-k Ω pull-up resistor to IOV _{DD} . Alternatively the terminal can be set to operate as ALARMOUT, a global alarm. Open drain output. This terminal goes low (active) when an alarm event is detected.
11	GPIO2/ADCTRIG	General purpose digital I/O 2 (default). This terminal is a bidirectional open-drain, digital input/output with internal 48-k Ω pull-up resistor to IOV _{DD} . Alternatively the terminal can be set to operate as ADCTRIG, an external conversion trigger, active low. The falling edge starts the sampling and conversion of the ADC.
12	GPIO3/DAV	General purpose digital I/O 3 (default). This terminal is a bidirectional open-drain, digital input/output with internal 48-k Ω pull-up resistor to IOV _{DD} . Alternatively the terminal can be set to operate as DAV, Data available indicator, active low output. In direct mode, the DAV terminal goes low (active) when the conversion ends. In auto mode, a 1 μ s pulse (active low) appears on this terminal when a conversion cycle finishes. DAV stays high when deactivated.
13	GPIO-4	General purpose digital I/O. This terminal is a bidirectional open-drain, digital input/output with internal 48-k Ω pull-up resistor to IOV _{DD} .
14	GPIO-5	
15	GPIO-6	
16	GPIO-7	
17	AV _{EE}	Lowest potential in the system. Typically tied to -12-V but if all DACs are set in a positive output range it should be connected to AGND.
18,19, 22, 24	DAC_A11, DAC_A10, DAC_A9, DAC_A8	DAC group A. These channels share the same range and clamp voltage.
20	AVSS _A	Negative analog supply for DAC group A. Sets the power-on-reset and clamp voltage values. Typically tied to AVEE when the DAC range for group A is set to -10 to 0-V or AGND for the positive output ranges.
21	VRANGE _A	This terminal determines the DAC range for DAC group A. If tied to AGND the DAC range is 0 to +5-V or 0 to +10-V. Otherwise if tied to +2.5-V (can be tied to REF_OUT terminals) the DAC range is -10 to 0-V.
23	AGND1	Analog ground. Ground reference point for all analog circuitry on the device, AGND. Connect AGND1, AGND2 and AGND3 to the same potential, AGND.
25	AV _{CC_AB}	Positive analog power for DAC groups A and B. Must be tied to AV _{CC_CD} .
26	VRANGE _B	This terminal determines the DAC range for DAC group B. If tied to AGND the DAC range is 0 to +5-V or 0 to +10-V. Otherwise if tied to +2.5-V (can be tied to REF_OUT terminals) the DAC range is -10 to 0-V.
27, 29	DAC_B7, DAC_B6	DAC group B. These channels share the same range and clamp voltage.
28	AVSS _B	Negative analog supply for DAC group B. Sets the power-on-reset and clamp voltage values. Typically tied to AVEE when the DAC range for group B is set to -10 to 0-V or AGND for the positive output ranges.
30	REF_OUT1	Reference output 1. Can be used to drive the VRANGE inputs.
31	AV _{DD1}	Analog supply voltage. (+4.5-V to +5.5-V)
32	REF_CMP	Internal reference compensation capacitor connection (connect 4.7- μ F capacitor between this terminal and AGND2).
33	AGND2	Analog ground. Ground reference point for all analog circuitry on the device, AGND. Connect AGND1, AGND2 and AGND3 to the same potential, AGND.
34	AV _{DD2}	Analog supply voltage. (+4.5-V to +5.5-V)
35-38	ADC_11, ADC_10, ADC_9, ADC_8	Bipolar analog inputs. Typically used to monitor the DAC_A8 to DAC_A11 outputs. The input range of these channels is -12.5-V to +12.5-V.
39-40	ADC_7, ADC_6	Bipolar analog inputs. Typically used to monitor the DAC_B6 to DAC_B7 outputs. The input range of these channels is -12.5-V to +12.5-V.

Terminal Functions (continued)

TERMINAL		DESCRIPTION
NUMBER	NAME	
41-45	LV_ADC16 to LV_ADC12	Unipolar analog inputs. These channels are used for general monitoring and their input range is 0 to $2 \times V_{REF}$.
46-49	ADC_5, ADC_4, ADC_3, ADC_2	Bipolar analog inputs. Typically used to monitor the DAC_D2 to DAC_D5 outputs. The input range of these channels is -12.5-V to +12.5-V.
50-51	ADC_1, ADC_0	Bipolar analog inputs. Typically used to monitor the DAC_C0 to DAC_C1 outputs. The input range of these channels is -12.5-V to +12.5-V.
52,54	DAC_C1, DAC_C0	DAC group C. These channels share the same range and clamp voltage.
53	AVSS _C	Negative analog supply for DAC group C. Sets the power-on-reset and clamp voltage values. Typically tied to AVEE when the DAC range for group C is set to -10 to 0-V or AGND for the positive output ranges.
55	VRANGE _C	This terminal determines the DAC range for DAC group C. If tied to AGND the DAC range is 0 to +5-V or 0 to +10-V. Otherwise if tied to +2.5-V (can be tied to REF_OUT terminals) the DAC range is -10 to 0-V.
56	REF_OUT2	Reference output 2. Can be used to drive the VRANGE inputs.
57	AVCC_CD	Positive analog power for DAC groups C and D. Must be tied to AVCC_AB.
58, 60, 63, 64	DAC_D5, DAC_D4, DAC_D3, DAC_D2	DAC group D. These channels share the same range and clamp voltage.
59	AGND3	Analog ground. Ground reference point for all analog circuitry on the device, AGND. Connect AGND1, AGND2 and AGND3 to the same potential, AGND.
61	VRANGE _D	This terminal determines the DAC range for DAC group D. If tied to AGND the DAC range is 0 to 5-V or 0 to 10-V. Otherwise if tied to +2.5-V (can be tied to REF_OUT terminals) the DAC range is -10 to 0-V.
62	AVSS _D	Negative analog supply for DAC group D. Sets the power-on-reset and clamp voltage values. Typically tied to AVEE when the DAC range for group D is set to -10 to 0-V or AGND for the positive output ranges.
—	THERMAL PAD	The thermal pad is located on the package underside. Should be tied to AV _{EE} or left unconnected.

7 Specifications

7.1 Absolute Maximum Ratings

over operating free-air temperature range (unless otherwise noted)⁽¹⁾

		MIN	MAX	UNIT
Supply voltage range	AV _{DD} to GND	-0.3	+6	V
	DV _{DD} to GND	-0.3	+6	V
	IOV _{DD} to GND	-0.3	DV _{DD}	V
	AV _{CC} to GND	-0.3	+18	V
	AV _{EE} to GND	-13	+0.3	V
	AV _{SS} _{A,B,C,D} to AV _{EE}	-0.3	+13	V
	AV _{CC} to AV _{SS} _{A,B,C,D}	-0.3	+26	V
	AV _{CC} to AV _{EE}	-0.3	+26	V
	DGND to AGND	-0.3	+0.3	V
Terminal voltage/ Current range	ADC_[0-11] analog input voltage to GND	-13	+13	V
	ADC_[0-11] analog input current	-10	+10	mA
	LV_ADC[12-16] analog input voltage to GND	-0.3	AV _{DD} + 0.3	V
	LV_ADC[12-16] analog input current	-10	+10	mA
	DAC outputs to GND	AV _{SS} - 0.3	AV _{CC} + 0.3	V
	REF_CMP to GND	-0.3	AV _{DD} + 0.3	V
	REF_OUT[1-2] to GND	-0.3	AV _{DD} + 0.3	V
	VRANGE _[A-D] to GND	-0.3	AV _{DD} + 0.3	V
	$\overline{\text{CS}}$, SCLK, SDI and $\overline{\text{RESET}}$ to GND	-0.3	IOV _{DD} + 0.3	V
	SDO to GND	-0.3	IOV _{DD} + 0.3	V
	GPIO[0-7] to GND	-0.3	IOV _{DD} + 0.3	V
GPIO[0-7] sinking current		5	mA	
Operating temperature range		-40	+125	°C
Junction temperature range (T _J max)		-40	+150	°C

- (1) Stresses beyond those listed under *Absolute Maximum Ratings* may cause permanent damage to the device. These are stress ratings only, which do not imply functional operation of the device at these or any other conditions beyond those indicated under *Recommended Operating Conditions*. Exposure to absolute-maximum-rated conditions for extended periods may affect device reliability.

7.2 Handling Ratings

PARAMETER	DEFINITION	MIN	MAX	UNIT
T _{stg}	Storage temperature range	-40	+150	°C
V _{ESD} ⁽¹⁾	Human body model (HBM) ESD stress voltage ⁽²⁾		2.0	kV
	Charged device model (CDM) ESD stress voltage ⁽³⁾		750	V

- (1) Electrostatic discharge (ESD) to measure device sensitivity and immunity to damage caused by assembly line electrostatic discharges in to the device.
- (2) Level listed above is the passing level per ANSI, ESDA, and JEDEC JS-001. JEDEC document JEP155 states that 500-V HBM allows safe manufacturing with a standard ESD control process.
- (3) Level listed above is the passing level per EIA-JEDEC JESD22-C101. JEDEC document JEP157 states that 250-V CDM allows safe manufacturing with a standard ESD control process.

7.3 Recommended Operating Conditions

over operating free-air temperature range (unless otherwise noted)

			MIN	NOM	MAX	UNIT
Supply voltage	AV_{DD}		4.5	5	5.5	V
	DV_{DD}	(DV_{DD} must be equal to AV_{DD})	4.5	5	5.5	V
	IOV_{DD}	(IOV_{DD} must be equal or less than DV_{DD})	1.8		5.5	V
	AV_{CC}		4.5	12	12.5	V
	AV_{EE}		-12.5	-12	0	V
	$AVSS_{A,B,C,D}$		AV_{EE}		0	V
Specified temperature range			-40	25	105	°C
Operating temperature range			-40	25	125	°C

7.4 Thermal Information

THERMAL METRIC ⁽¹⁾		AMC7832	UNIT
		PAP (64 TERMINALS)	
θ_{JA}	Junction-to-ambient thermal resistance	26.5	°C/W
θ_{JCTop}	Junction-to-case (top) thermal resistance	7.9	
θ_{JB}	Junction-to-board thermal resistance	9.9	
Ψ_{JT}	Junction-to-top characterization parameter	0.2	
Ψ_{JB}	Junction-to-board characterization parameter	9.8	
θ_{JCbott}	Junction-to-case (bottom) thermal resistance	0.3	

(1) For more information about traditional and new thermal metrics, see the *IC Package Thermal Metrics* application report, [SPRA953](#).

7.5 Electrical Characteristics

The electrical ratings specified in this section apply to all specifications in this document, unless otherwise noted. These specifications are interpreted as conditions that do not degrade the device parametric or functional specifications for the life of the product containing it. $AV_{DD} = DV_{DD} = +4.5$ to $+5.5$ -V, $AV_{CC} = +12$ -V, $AV_{EE} = -12$ -V, $IOV_{DD} = +1.8$ to $+5.5$ -V, $AGND = DGND = 0$ -V, $AVSS_{A,B,C,D} = 0$ -V (DAC groups in positive ranges) or -12 -V (DAC groups in negative range), DAC output range = 0 to 10-V for all groups, no load on the DACs, $T_A = -40^\circ\text{C}$ to $+105^\circ\text{C}$ (unless otherwise noted)

PARAMETER		TEST CONDITIONS	MIN	TYP	MAX	UNIT
DAC SPECIFICATIONS						
DAC DC ACCURACY						
Resolution			12			Bits
INL	Relative accuracy	Measured by line passing through codes 020h and FFFh. 0 to +10-V and -10 to 0-V ranges			±1	LSB
		Measured by line passing through codes 040h and FFFh. 0 to +5-V range			±1.5	
DNL	Differential nonlinearity	Specified monotonic. Measured by line passing through codes 020h and FFFh. 0 to +10-V and -10 to 0-V ranges. Measured by line passing through codes 040h and FFFh. 0 to +5-V range		±0.3	±1	LSB
TUE	Total unadjusted error ⁽¹⁾	$T_A = 25^\circ\text{C}$ 0 to +10-V range and -10 to 0-V ranges			±20	mV
		$T_A = 25^\circ\text{C}$ 0 to +5-V range			±10	mV
	Offset error	$T_A = 25^\circ\text{C}$, Measured by line passing through codes 020h and FFFh, 0 to +10-V range			±5	mV
		$T_A = 25^\circ\text{C}$, Measured by line passing through codes 040h and FFFh, 0 to +5-V range			±5	mV
	Zero-code error	$T_A = 25^\circ\text{C}$, Code 000h, -10 to 0-V range			±20	mV
	Gain error ⁽¹⁾	$T_A = 25^\circ\text{C}$, Measured by line passing through codes 020h and FFFh, 0 to +10-V and -10 to 0-V ranges			±0.2	%FSR
		$T_A = 25^\circ\text{C}$, Measured by line passing through codes 040h and FFFh, 0 to +5-V range			±0.2	%FSR
	Offset temperature coefficient	0 to +10-V and 0 to +5-V ranges		±1		ppm/°C
	Zero-code temperature coefficient	-10 to 0-V range		±2		ppm/°C
	Gain temperature coefficient	All output ranges		±1		ppm/°C
DAC OUTPUT CHARACTERISTICS						
	Full-scale output voltage range ⁽²⁾	VRANGE _n terminal set to AGND DAC-5VRANGE _n bit set to 0	0		10	V
		VRANGE _n terminal set to AGND DAC-5VRANGE _n bit set to 1	0		5	V
		VRANGE _n terminal set to +2.5V DAC-5VRANGE _n bit set to 0	-10		0	V
	Output voltage settling time	Transition: Code 400h to C00h to within ½ LSB, $R_L = 2\text{k}\Omega$, $C_L = 200\text{pF}$, 0 to +10-V and -10 to 0-V ranges		10		µs
		Transition: Code 400h to C00h to within ½ LSB, $R_L = 2\text{k}\Omega$, $C_L = 200\text{pF}$, 0 to +5-V range		8		µs

(1) Internal reference contribution not included.

(2) The output voltage cannot be greater than AV_{CC} or lower than AV_{SS} . See the [DAC Output Range Selection](#) section for more details.

Electrical Characteristics (continued)

The electrical ratings specified in this section apply to all specifications in this document, unless otherwise noted. These specifications are interpreted as conditions that do not degrade the device parametric or functional specifications for the life of the product containing it. $AV_{DD} = DV_{DD} = +4.5$ to $+5.5$ -V, $AV_{CC} = +12$ -V, $AV_{EE} = -12$ -V, $IOV_{DD} = +1.8$ to $+5.5$ -V, $AGND = DGND = 0$ -V, $AVSS_{A,B,C,D} = 0$ -V (DAC groups in positive ranges) or -12 -V (DAC groups in negative range), DAC output range = 0 to 10-V for all groups, no load on the DACs, $T_A = -40^\circ\text{C}$ to $+105^\circ\text{C}$ (unless otherwise noted)

PARAMETER		TEST CONDITIONS	MIN	TYP	MAX	UNIT
	Slew rate	Transition: Code 400h to C00h to within $\frac{1}{2}$ LSB, $R_L = 2\text{k}\Omega$, $C_L = 200\text{pF}$, all DAC output ranges		1.25		V/ μs
	Short-circuit current	Full-scale current shorted to AV_{SS} or AV_{CC}		45		mA
	Load current	Source and/or sink with 1V headroom from AV_{CC}/AV_{SS} , voltage drop $< 25\text{mV}$ ⁽³⁾	± 15			mA
		Source and/or sink with 300mV headroom from AV_{CC}/AV_{SS} , voltage drop $< 25\text{mV}$	± 10			mA
		Source with 100mV headroom from AV_{CC} ⁽⁴⁾	0			mA
	Maximum capacitive load ⁽⁵⁾	$R_L = \infty$	0		10	nF
	DC output impedance	Code set to 800h, $\pm 15\text{mA}$		1		Ω
	Power-on overshoot	$AV_{EE} = AVSS_{A,B,C,D} = GND$, $AV_{CC} = 0$ to $+12\text{V}$, 2ms ramp		50		mV
	Glitch energy	Transition: Code 7FFh to 800h; 800h to 7FFh		1		nV-s
	Output noise	$T_A = 25^\circ\text{C}$, 1kHz, code 800h, includes internal reference noise		520		nV/ $\sqrt{\text{Hz}}$
		$T_A = 25^\circ\text{C}$, integrated noise from 0.1Hz to 10Hz, code 800h, includes internal reference noise		20		μV_{PP}
CLAMP OUTPUTS						
	Clamp output voltage ⁽⁶⁾	DAC output range: 0 to $+10$ -V		0		V
		DAC output range: 0 to $+5$ -V		0		V
		DAC output range: -10 to 0 -V, $AV_{SS} = -12$ -V		$AV_{SS} + 2$		V

(3) If all channels are loaded with 15mA simultaneously care must be taken to ensure the thermal conditions for the device are not exceeded.

(4) Not tested during production. Specified by design.

(5) To be sampled during initial release to ensure compliance; not subject to production testing.

(6) No DAC load to AV_{SS} .

Electrical Characteristics (continued)

The electrical ratings specified in this section apply to all specifications in this document, unless otherwise noted. These specifications are interpreted as conditions that do not degrade the device parametric or functional specifications for the life of the product containing it. $AV_{DD} = DV_{DD} = +4.5$ to $+5.5$ -V, $AV_{CC} = +12$ -V, $AV_{EE} = -12$ -V, $IOV_{DD} = +1.8$ to $+5.5$ -V, $AGND = DGND = 0$ -V, $AVSS_{A,B,C,D} = 0$ -V (DAC groups in positive ranges) or -12 -V (DAC groups in negative range), DAC output range = 0 to 10-V for all groups, no load on the DACs, $T_A = -40^{\circ}\text{C}$ to $+105^{\circ}\text{C}$ (unless otherwise noted)

PARAMETER		TEST CONDITIONS	MIN	TYP	MAX	UNIT
ADC AND TEMPERATURE SENSOR SPECIFICATIONS						
	Resolution		12			Bits
INL	Integral nonlinearity	Unipolar input channels	± 0.5		± 1	LSB
		Bipolar input channels	± 0.75		± 1.5	LSB
DNL	Differential nonlinearity	Specified monotonic. All input channels	± 0.5		± 1	LSB
UNIPOLAR ANALOG INPUTS: LV_ADC12 to LV_ADC16						
	Absolute input voltage range		$\text{GND} - 0.2$		$AV_{DD} + 0.2$	V
	Full scale input range		0		$2 \times V_{REF}$	V
	Input capacitance	V_{REF} measured at REF_CMP terminal	34			pF
	DC input leakage current	Unselected ADC input			± 10	μA
	Offset error		± 2		± 5	LSB
	Offset error match		± 2.5			LSB
	Gain error ⁽⁷⁾		± 1		± 5	LSB
	Gain error match		± 1			LSB
	Update time	Single unipolar input, temperature sensor disabled	11.5			μs
BIPOLAR ANALOG INPUTS: ADC_0 to ADC_11						
	Absolute input voltage range		-13		+13	V
	Full scale input range		-12.5		12.5	V
	Input resistance		175			k Ω
	Offset error		± 5		± 10	LSB
	Gain error ⁽⁷⁾		± 5		± 10	LSB
	Update time	Single bipolar input, temperature sensor disabled	34.5			μs
TEMPERATURE SENSOR						
	Operating range		-40		125	$^{\circ}\text{C}$
	Accuracy	$T_A = -40^{\circ}\text{C}$ to 125°C , $AV_{DD} = +5$ -V	± 1.25		± 2.5	$^{\circ}\text{C}$
	Resolution	LSB size	0.25			$^{\circ}\text{C}$
	Update time	All ADC input channels disabled	256			μs
AUTOCYCLE UPDATE TIME						
	Autocycle update time	All 17 ADC inputs enabled, temperature sensor disabled	471.5			μs
		All 17 ADC inputs and temperature sensor enabled	727.5			μs

(7) Internal reference contribution not included.

Electrical Characteristics (continued)

The electrical ratings specified in this section apply to all specifications in this document, unless otherwise noted. These specifications are interpreted as conditions that do not degrade the device parametric or functional specifications for the life of the product containing it. $AV_{DD} = DV_{DD} = +4.5$ to $+5.5$ -V, $AV_{CC} = +12$ -V, $AV_{EE} = -12$ -V, $IOV_{DD} = +1.8$ to $+5.5$ -V, $AGND = DGND = 0$ -V, $AVSS_{A,B,C,D} = 0$ -V (DAC groups in positive ranges) or -12 -V (DAC groups in negative range), DAC output range = 0 to 10-V for all groups, no load on the DACs, $T_A = -40^{\circ}\text{C}$ to $+105^{\circ}\text{C}$ (unless otherwise noted)

PARAMETER		TEST CONDITIONS	MIN	TYP	MAX	UNIT
INTERNAL REFERENCE SPECIFICATIONS						
INTERNAL REFERENCE (Internal reference not accessible)						
	Initial accuracy	$T_A = 25^{\circ}\text{C}$	2.4925	2.5	2.5075	V
	Reference temp. coefficient ⁽⁸⁾			12	35	ppm/ $^{\circ}\text{C}$
REF_OUT[1-2] BUFFERS⁽⁹⁾						
	Reference buffer offset	$T_A = 25^{\circ}\text{C}$			± 2.5	mV
	Capacitive load stability				100	pF
INTERNAL ADC REFERENCE BUFFER						
	Reference buffer offset	$T_A = 25^{\circ}\text{C}$			± 5	mV
GENERAL SPECIFICATIONS						
DIGITAL LOGIC: GPIO						
V_{IH}	High-level input voltage	$IOV_{DD} = +1.8$ to $+5.5$ -V	$0.7 \times IOV_{DD}$			V
V_{IL}	Low-level input voltage	$IOV_{DD} = +1.8$ -V			0.45	V
		$IOV_{DD} = +2.7$ to $+5.5$ -V			$0.3 \times IOV_{DD}$	V
V_{OL}	Low-level output voltage	$IOV_{DD} = +1.8$ -V, $I_{load} = -2$ -mA			0.4	V
		$IOV_{DD} = +5.5$ -V, $I_{load} = -5$ -mA			0.4	V
	Input impedance	To IOV_{DD}	48			k Ω
DIGITAL LOGIC: All Except GPIO						
V_{IH}	High-level input voltage	$IOV_{DD} = +1.8$ to $+5.5$ -V	$0.7 \times IOV_{DD}$			V
V_{IL}	Low-level input voltage	$IOV_{DD} = +1.8$ -V			0.45	V
		$IOV_{DD} = +2.7$ to $+5.5$ -V			$0.3 \times IOV_{DD}$	V
V_{OH}	High-level output voltage	$I_{load} = -1$ -mA	$IOV_{DD} - 0.4$			V
V_{OL}	Low-level output voltage	$I_{load} = +1$ -mA			0.4	V
	High-impedance leakage				± 5	μA
	High-impedance output capacitance		10			pF
TIMING REQUIREMENTS						
	Reset delay	Delay to normal operation from reset		100	250	μs
	Power-down recovery time				70	μs
	Clamp shutdown delay	$C_L = 10$ nF	100			μs
	Convert pulse width		20			ns
	Reset pulse width		20			ns
POWER-SUPPLY REQUIREMENTS						
I_{AVDD}	AV_{DD} supply current	No DAC load, all DACs at 800h code and ADC at the fastest auto conversion rate			10	mA
I_{AVCC}	AV_{CC} supply current				10	mA
I_{AVSS}	AV_{SS} supply current		-10			mA
I_{DVDD}	DV_{DD} supply current				3	mA
I_{IOVDD}	IOV_{DD} supply current				15	μA
	Power consumption				160	mW

(8) Not tested during production. Specified by design and characterization.

(9) Intended to drive the $VRANGE_{A,B,C,D}$ inputs only. An external buffer amplifier with high impedance input is required to drive any additional external load.

Electrical Characteristics (continued)

The electrical ratings specified in this section apply to all specifications in this document, unless otherwise noted. These specifications are interpreted as conditions that do not degrade the device parametric or functional specifications for the life of the product containing it. $AV_{DD} = DV_{DD} = +4.5$ to $+5.5$ -V, $AV_{CC} = +12$ -V, $AV_{EE} = -12$ -V, $IOV_{DD} = +1.8$ to $+5.5$ -V, $AGND = DGND = 0$ -V, $AVSS_{A,B,C,D} = 0$ -V (DAC groups in positive ranges) or -12 -V (DAC groups in negative range), DAC output range = 0 to 10-V for all groups, no load on the DACs, $T_A = -40^{\circ}\text{C}$ to $+105^{\circ}\text{C}$ (unless otherwise noted)

PARAMETER		TEST CONDITIONS	MIN	TYP	MAX	UNIT
I_{AVDD}	AV_{DD} supply current	Power down mode			2	mA
I_{AVCC}	AV_{CC} supply current				2	mA
I_{AVSS}	AV_{SS} supply current		-5.5			mA
I_{DVDD}	DV_{DD} supply current				2	mA
I_{IOVDD}	IOV_{DD} supply current				12	μA
	Power consumption			55		mW

7.6 Timing Requirements - Serial Interface⁽¹⁾⁽²⁾

$AV_{DD} = DV_{DD} = +4.5$ to $+5.5$ -V, $AV_{CC} = +12$ -V, $AV_{EE} = -12$ -V, $AGND = DGND = AVSS_{A,B,C,D} = 0$ -V, DAC output range = 0 to +10-V for all groups, no load on the DACs, $T_A = -40^\circ\text{C}$ to $+105^\circ\text{C}$ (unless otherwise noted)

PARAMETER		TEST CONDITIONS	MIN	TYP	MAX	UNIT
IOVDD = +1.8-V to +2.7-V						
f_{SCLK}	SCLK frequency				15	MHz
t_P	SCLK period		66.67			ns
t_{PH}	SCLK pulse width high		27			ns
t_{PL}	SCLK pulse width low		27			ns
t_{SU}	SDI setup		10			ns
t_H	SDI hold		10			ns
t_{ODZ}	SDO driven to tri-state		0		15	ns
t_{OZD}	SDO tri-state to driven		0		20	ns
t_{OD}	SDO output delay		0		20	ns
t_{CSS}	\overline{CS} setup		5			ns
t_{CSH}	\overline{CS} hold		20			ns
t_{IAG}	Inter-access gap		10			ns
IOVDD = +2.7-V to +5.5-V						
f_{SCLK}	SCLK frequency				20	MHz
t_P	SCLK period		50			ns
t_{PH}	SCLK pulse width high		22.5			ns
t_{PL}	SCLK pulse width low		20			ns
t_{SU}	SDI setup		10			ns
t_H	SDI hold		10			ns
t_{ODZ}	SDO driven to tri-state		0		9	ns
t_{OZD}	SDO tri-state to driven		0		12	ns
t_{OD}	SDO output delay		0		15	ns
t_{CSS}	\overline{CS} setup		5			ns
t_{CSH}	\overline{CS} hold		20			ns
t_{IAG}	Inter-access gap		10			ns

- (1) Specified by design and characterization. Not tested during production.
(2) SDO loaded with 10-pF load capacitance for SDO timing specifications.

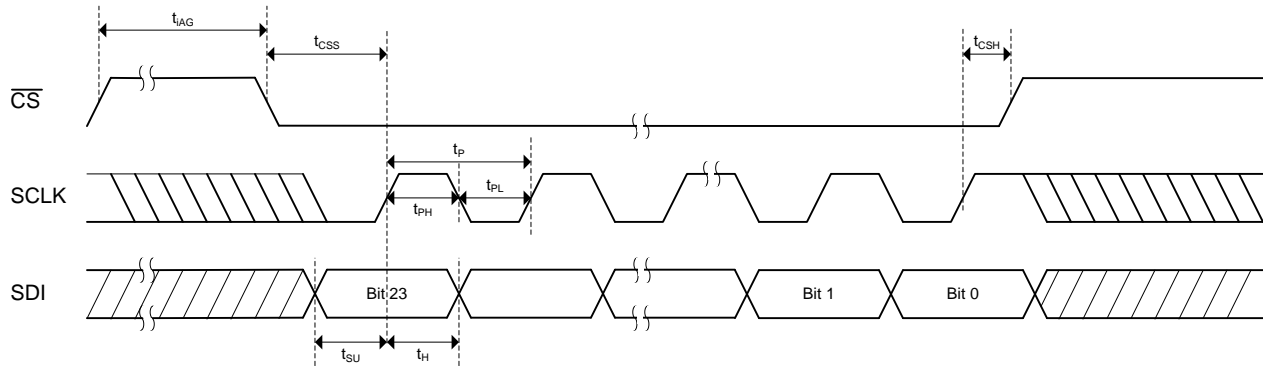

Figure 1. Serial Interface Write Timing Diagram

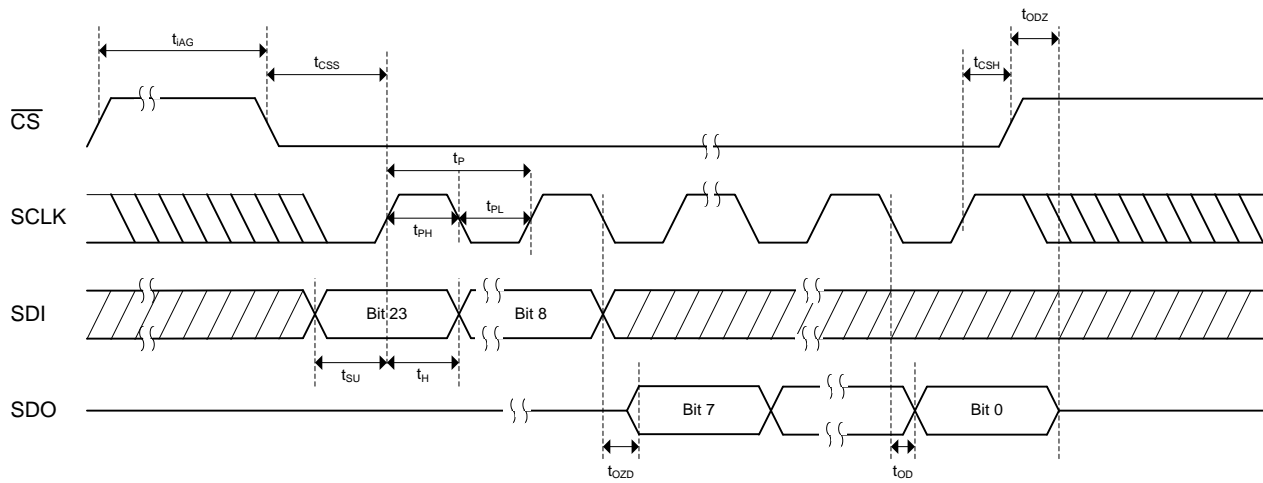
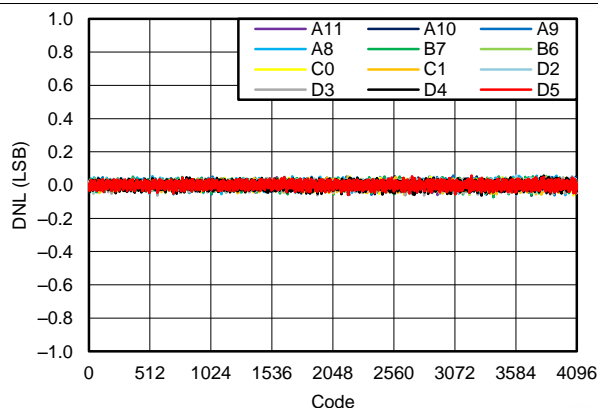

Figure 2. Serial Interface Read Timing Diagram

7.7 Typical Characteristics: DAC



T = 25°C, 0V to 10V range

Figure 3. Differential Linearity Error vs Code

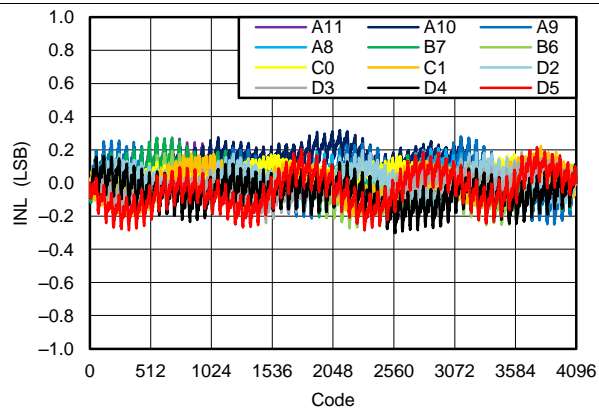

T = 25°C, 0V to 10V range

Figure 4. Linearity Error vs Code

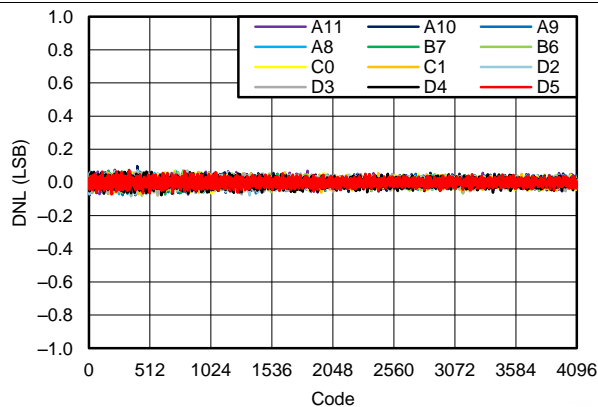

T = 25°C, -10V to 0V range

Figure 5. Differential Linearity Error vs Code

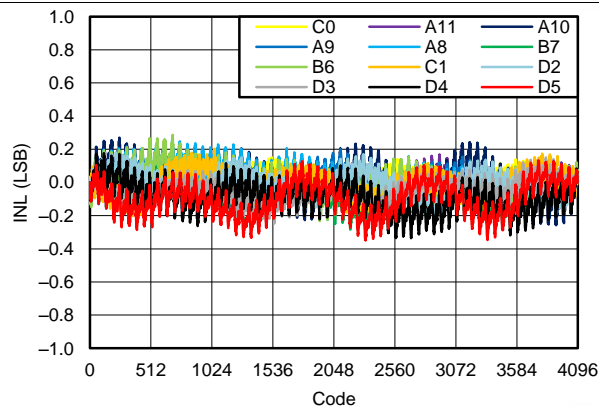

T = 25°C, -10V to 0V range

Figure 6. Linearity Error vs Code

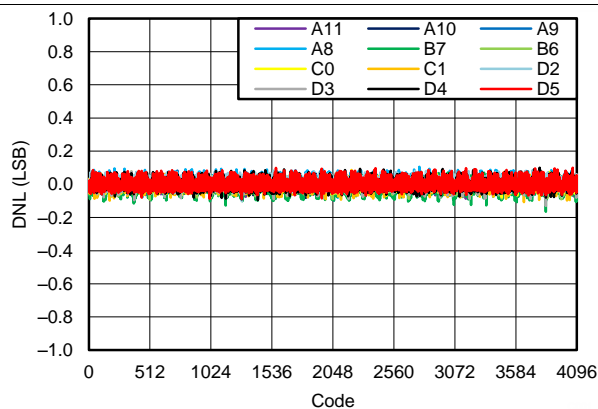

T = 25°C, 0V to 5V range

Figure 7. Differential Linearity Error vs Code

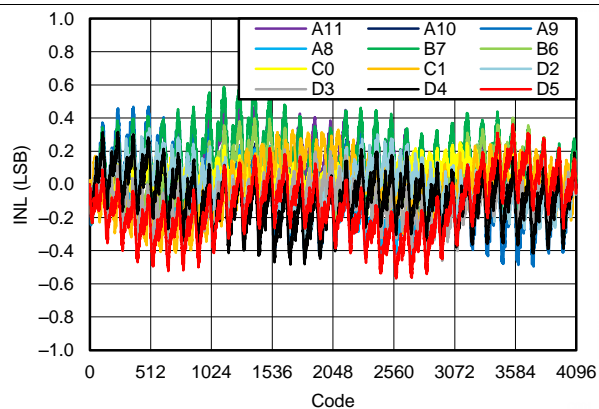

T = 25°C, 0V to 5V range

Figure 8. Linearity Error vs Code

Typical Characteristics: DAC (continued)

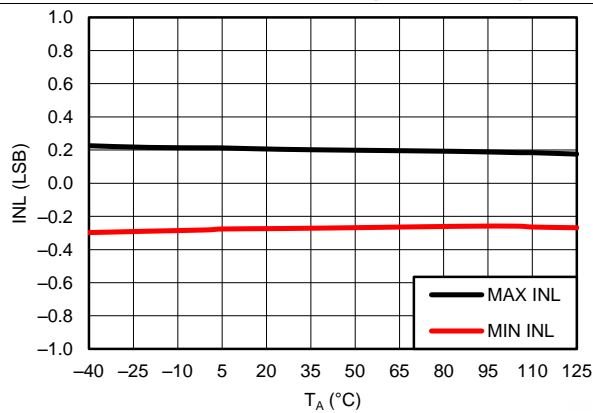

0V to 10V range

Figure 9. Linearity Error vs Temperature

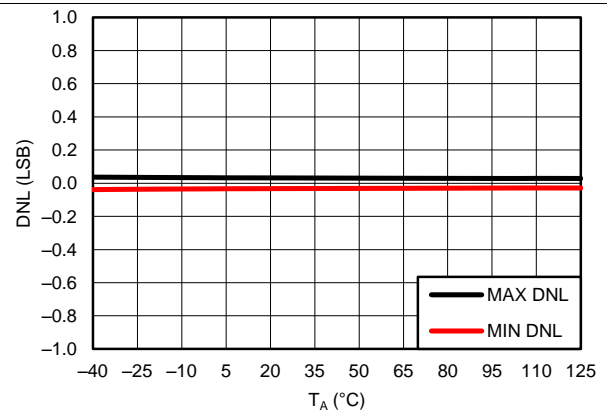

0V to 10V range

Figure 10. Differential Linearity Error vs Temperature

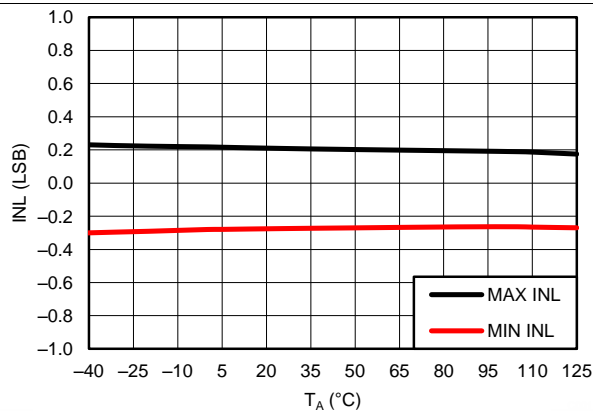

-10V to 0V range

Figure 11. Linearity Error vs Temperature

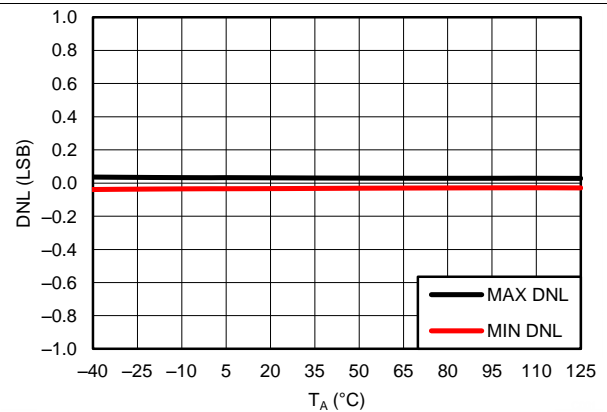

-10V to 0V range

Figure 12. Differential Linearity Error vs Temperature

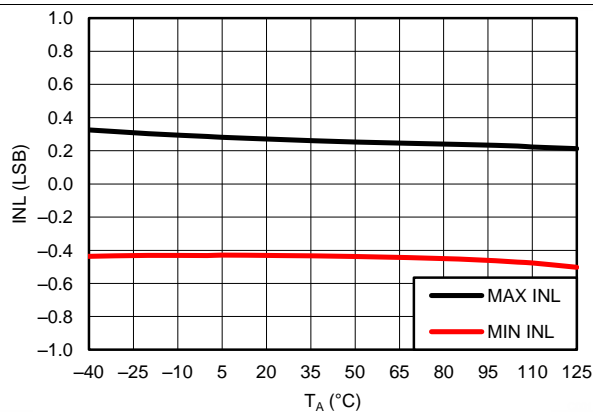

0V to 5V range

Figure 13. Linearity Error vs Temperature

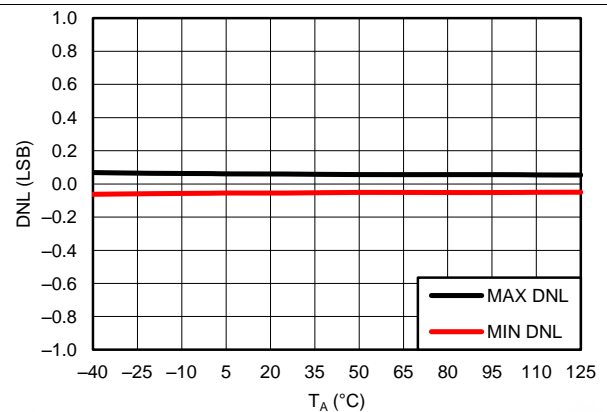

0V to 5V range

Figure 14. Differential Linearity Error vs Temperature

Typical Characteristics: DAC (continued)

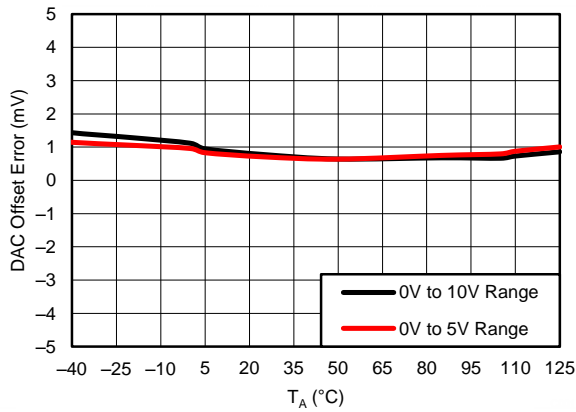
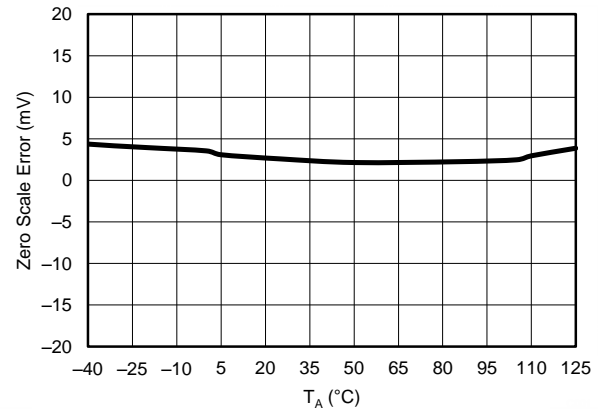

Figure 15. Offset Error vs Temperature



-10V to 0V range

Figure 16. Zero-Scale Error vs Temperature

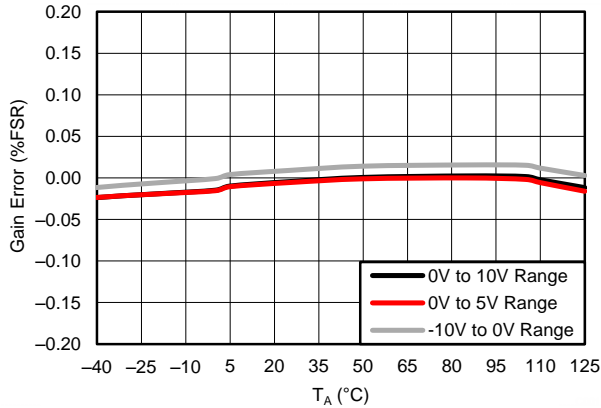
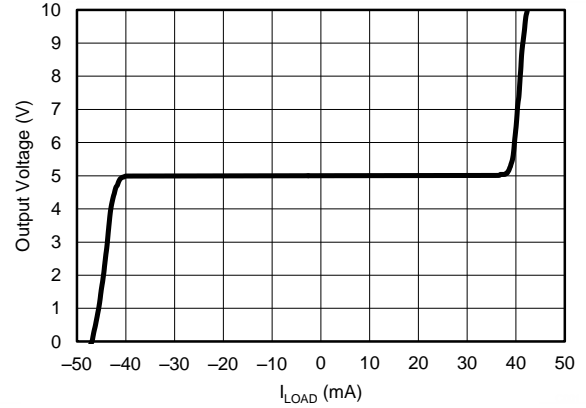
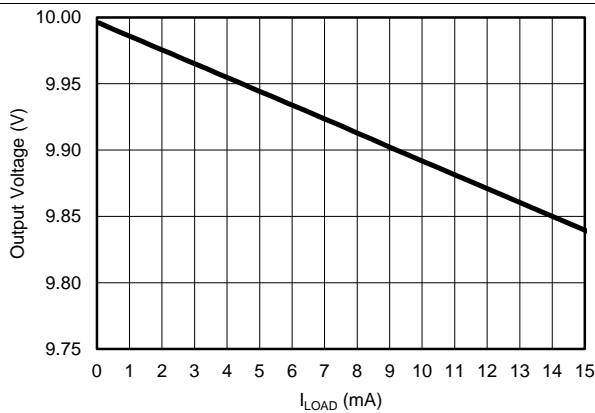

Figure 17. Gain Error vs Temperature



T = 25°C, Input Code 0x800, 0 to 10V range

Figure 18. Output Voltage vs Load Current



T = 25°C, AV_{CC} = 10V, AV_{EE} = 0V, Input Code 0xFFFF, 0 to 10V range

Figure 19. Source Current

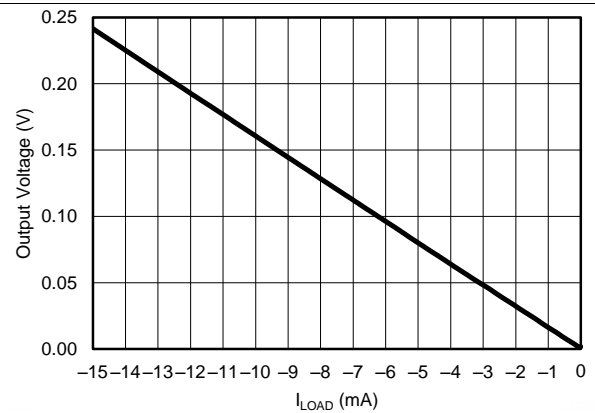

T = 25°C, AV_{CC} = 10V, AV_{EE} = 0V, Input Code 0x000, 0 to 10V range

Figure 20. Sink Current

Typical Characteristics: DAC (continued)

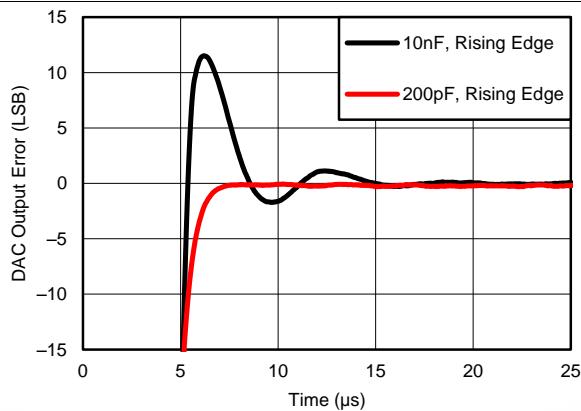

T = 25°C, Code 0x400 to 0xC00 to within 1/2 LSB

Figure 21. Settling Time vs Load Capacitance

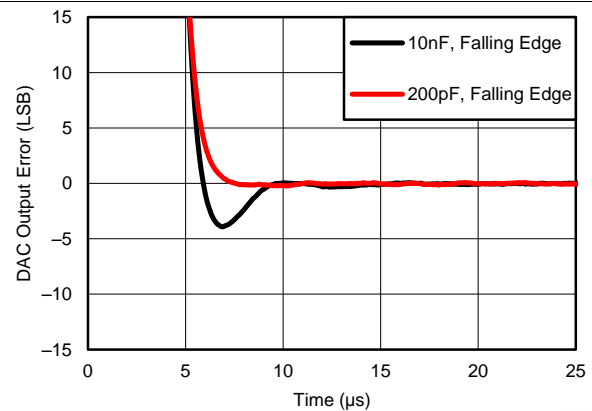

T = 25°C, Code 0xC00 to 0x400 to within 1/2 LSB

Figure 22. Settling Time vs Load Capacitance

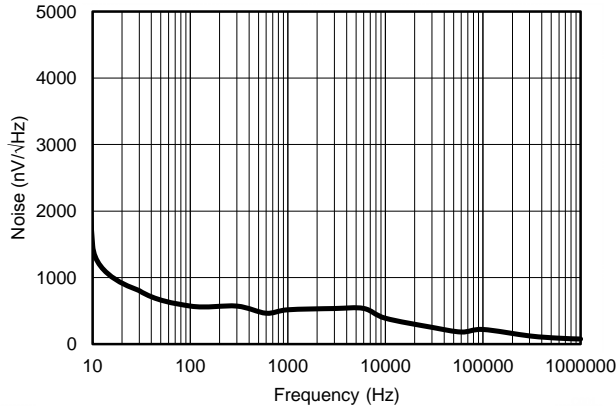

T = 25°C, Input Code 0x800

Figure 23. Noise Voltage vs Frequency

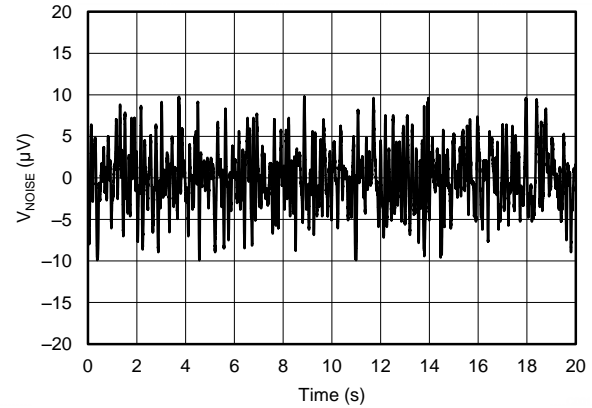

T = 25°C, Input Code 0x800

Figure 24. 0.1Hz to 10Hz Noise

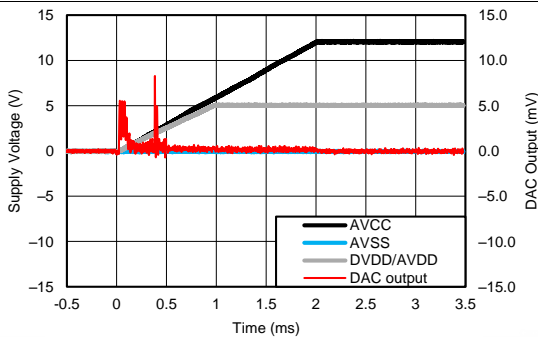

T = 25°C, AV_{SS} = AV_{EE} = AGND, AV_{CC} 0 to 12V, 2 ms ramp

Figure 25. Power-On Overshoot Single Supply

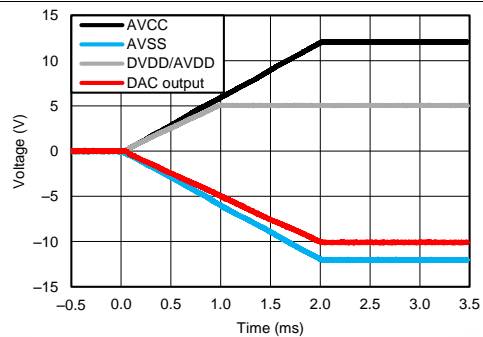

T = 25°C, AV_{SS} = AV_{EE} = -12V, AV_{CC} 0 to 12V, 2 ms ramp

Figure 26. Power-On Overshoot Dual Supply

Typical Characteristics: DAC (continued)

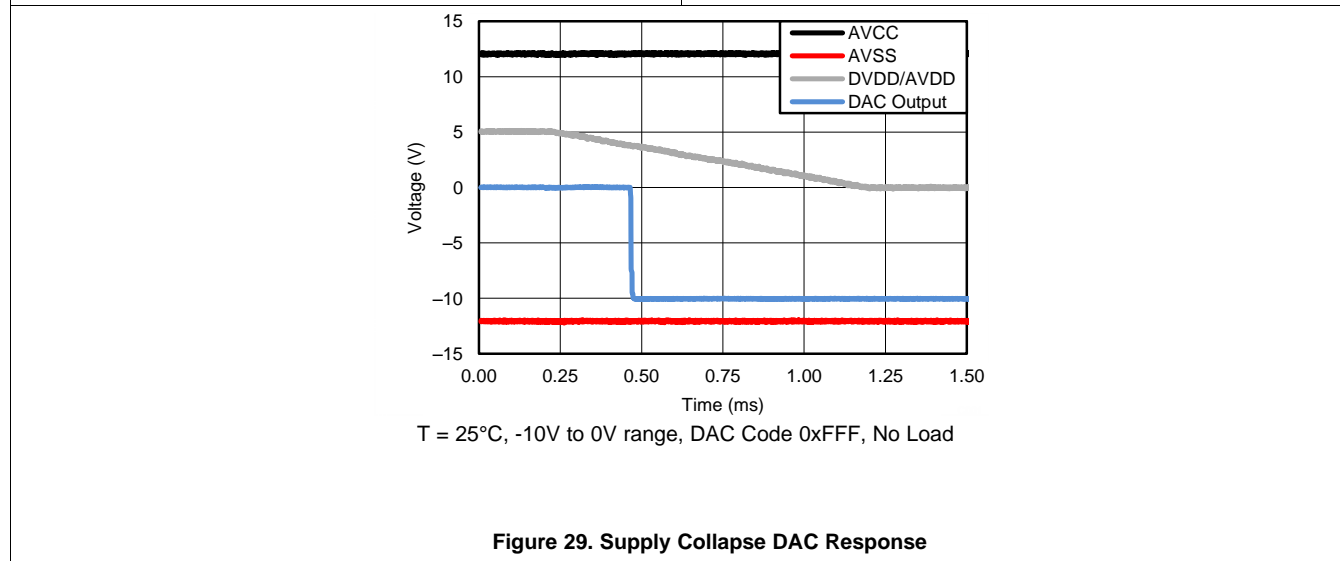
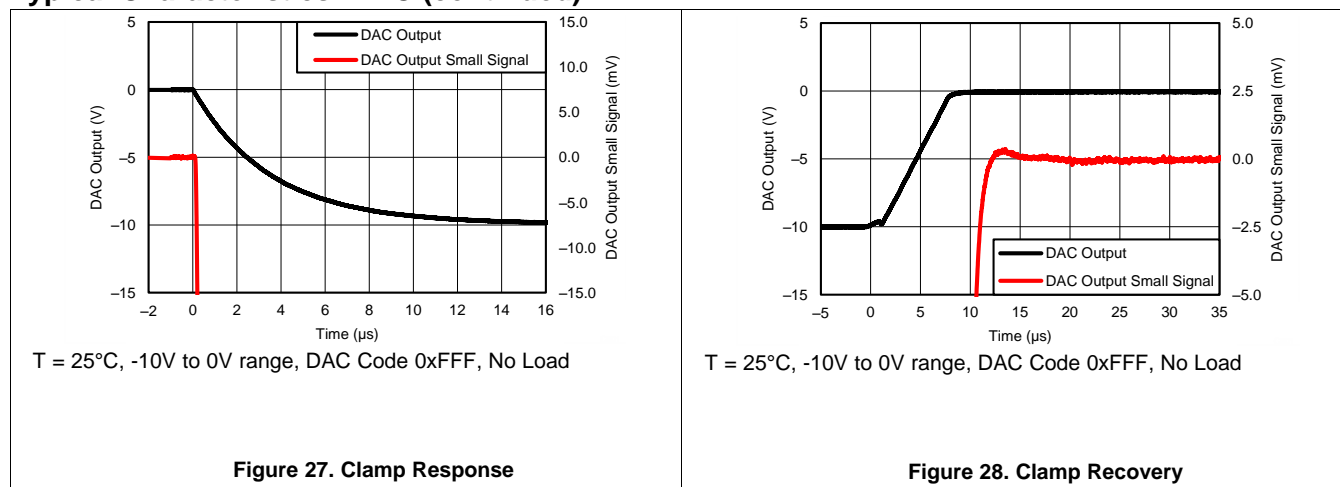

7.8 Typical Characteristics: ADC

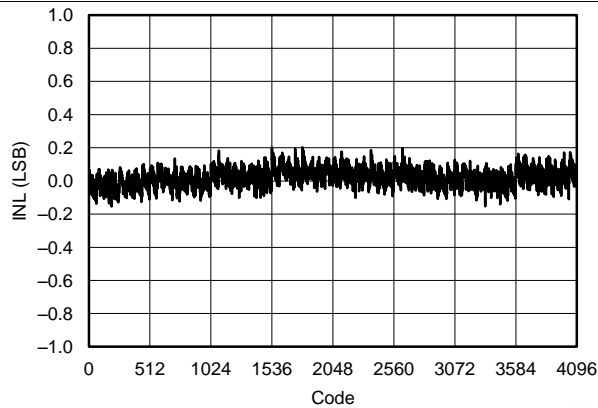

T = 25°C, Unipolar Input

Figure 30. Linearity Error vs Code

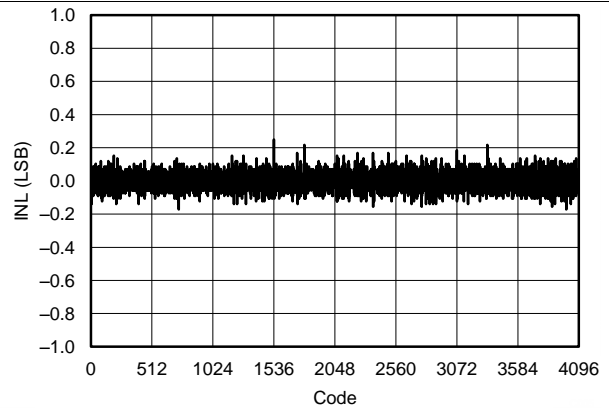

T = 25°C, Unipolar Input

Figure 31. Differential Linearity Error vs Code

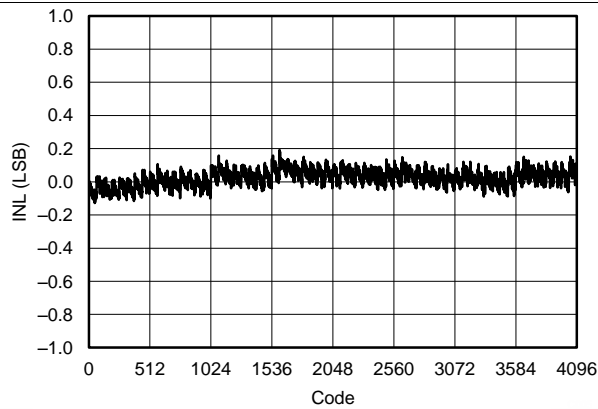

T = 25°C, Bipolar Input

Figure 32. Linearity Error vs Code

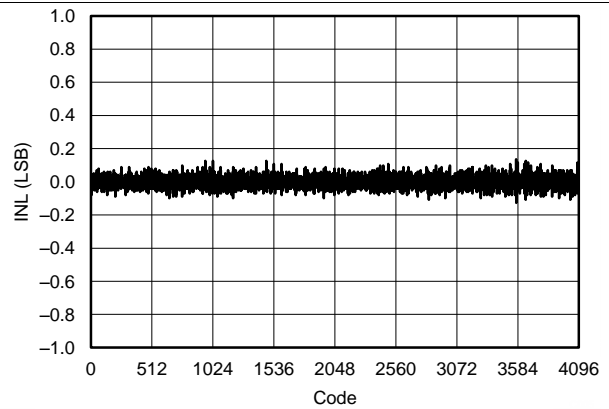

T = 25°C, Bipolar Input

Figure 33. Differential Linearity Error vs Code

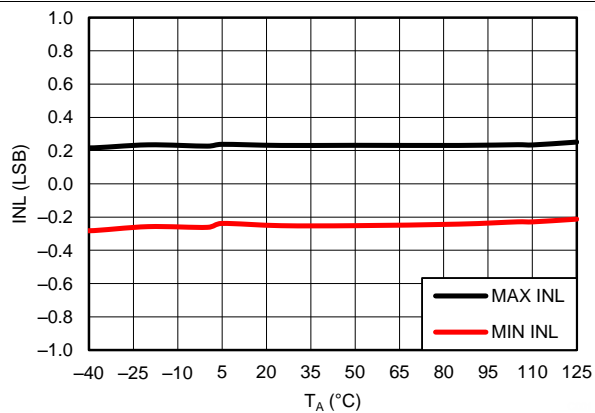

Unipolar input

Figure 34. Linearity Error vs Temperature

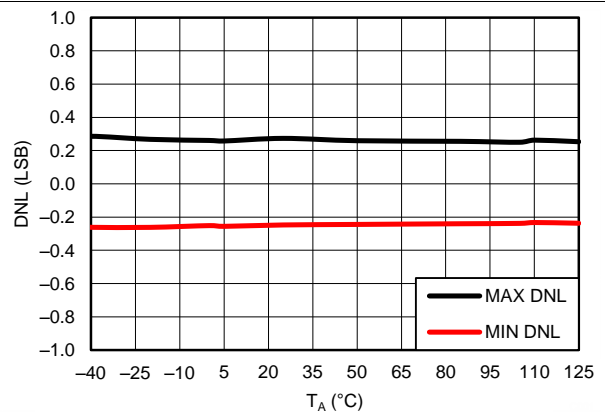

Unipolar input

Figure 35. Differential Linearity Error vs Temperature

Typical Characteristics: ADC (continued)

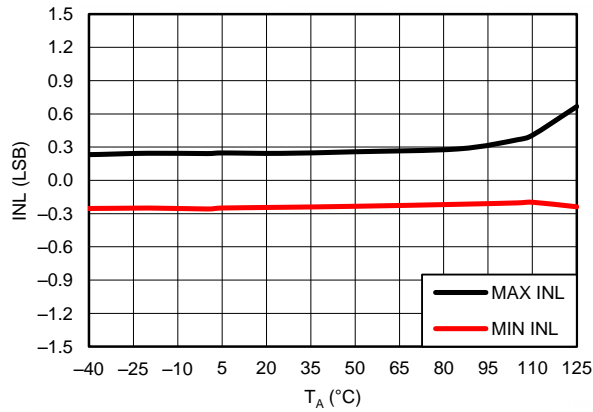

Bipolar input

Figure 36. Linearity Error vs Temperature

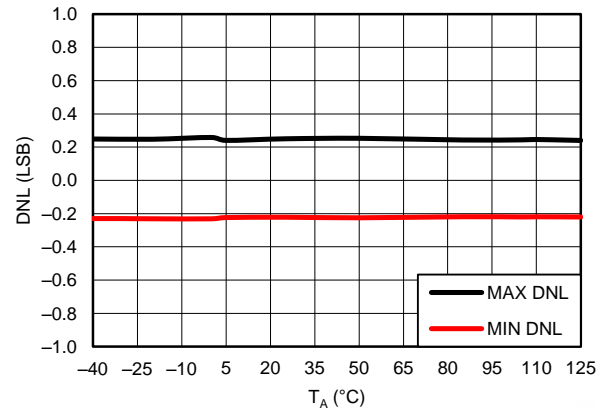

Bipolar input

Figure 37. Differential Linearity Error vs Temperature

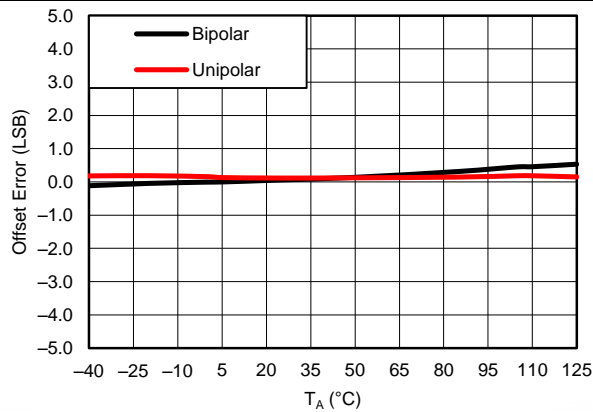

Figure 38. Offset vs Temperature

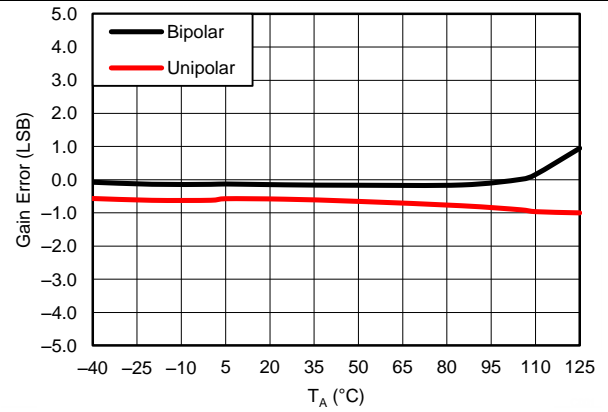

Figure 39. Gain Error vs Temperature

7.9 Typical Characteristics: Reference

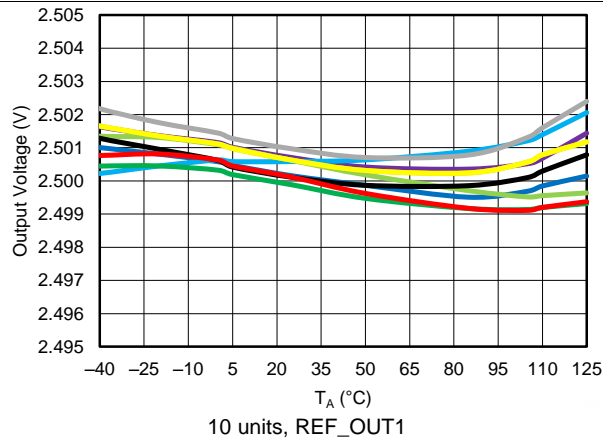

Figure 40. Output Voltage vs Temperature

7.10 Typical Characteristics: Temperature Sensor

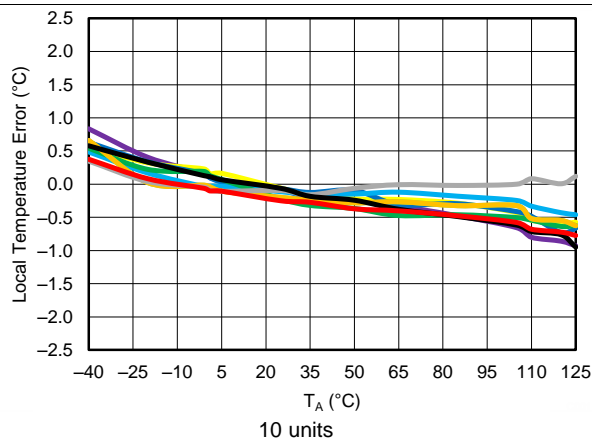

Figure 41. Temperature Sensor Error vs Temperature

8 Detailed Description

8.1 Overview

The AMC7832 is a highly integrated analog monitoring and control solution capable of voltage and temperature supervision. The AMC7832 includes the following:

- Twelve, 12-bit digital-to-analog converters (DACs) with adjustable output ranges
 - Output ranges of 0 to +5-V, 0 to +10-V and -10 to 0-V
 - The DAC power-on and clamp voltage can be terminal-selected between GND and AVSS
 - The DACs can be configured to clamp automatically upon detection of an alarm event
- A multi-channel, 12-bit analog-to-digital converter (ADC) for voltage and temperature sensing
 - 12 bipolar inputs: -12.5-V to +12.5-V input range
 - 5 precision inputs with programmable threshold detectors: 0 to +5-V input range
 - Internal temperature sensor
- Internal precision reference
- Eight General Purpose I/O (GPIO) ports
- Communication with the device is done through a 4-wire SPI compatible interface supporting +1.8-V to +5.5-V operation

The AMC7832 is characterized for operation over the temperature range of -40°C to 125°C thus making it suitable for harsh condition applications and is available in a 10mm x 10mm 64-terminal HTQFP PowerPAD package.

The AMC7832's high-integration make it an ideal all-in-one, low-cost, bias control circuit for the power amplifiers (PA) found in multi-channel RF communication systems. The flexible DAC output ranges allow the device to be used as a biasing solution for a large variety of transistor technologies such as LDMOS, GaAs and GaN. The AMC7832 feature set is similarly beneficial in general purpose monitor and control systems.

8.2 Functional Block Diagram

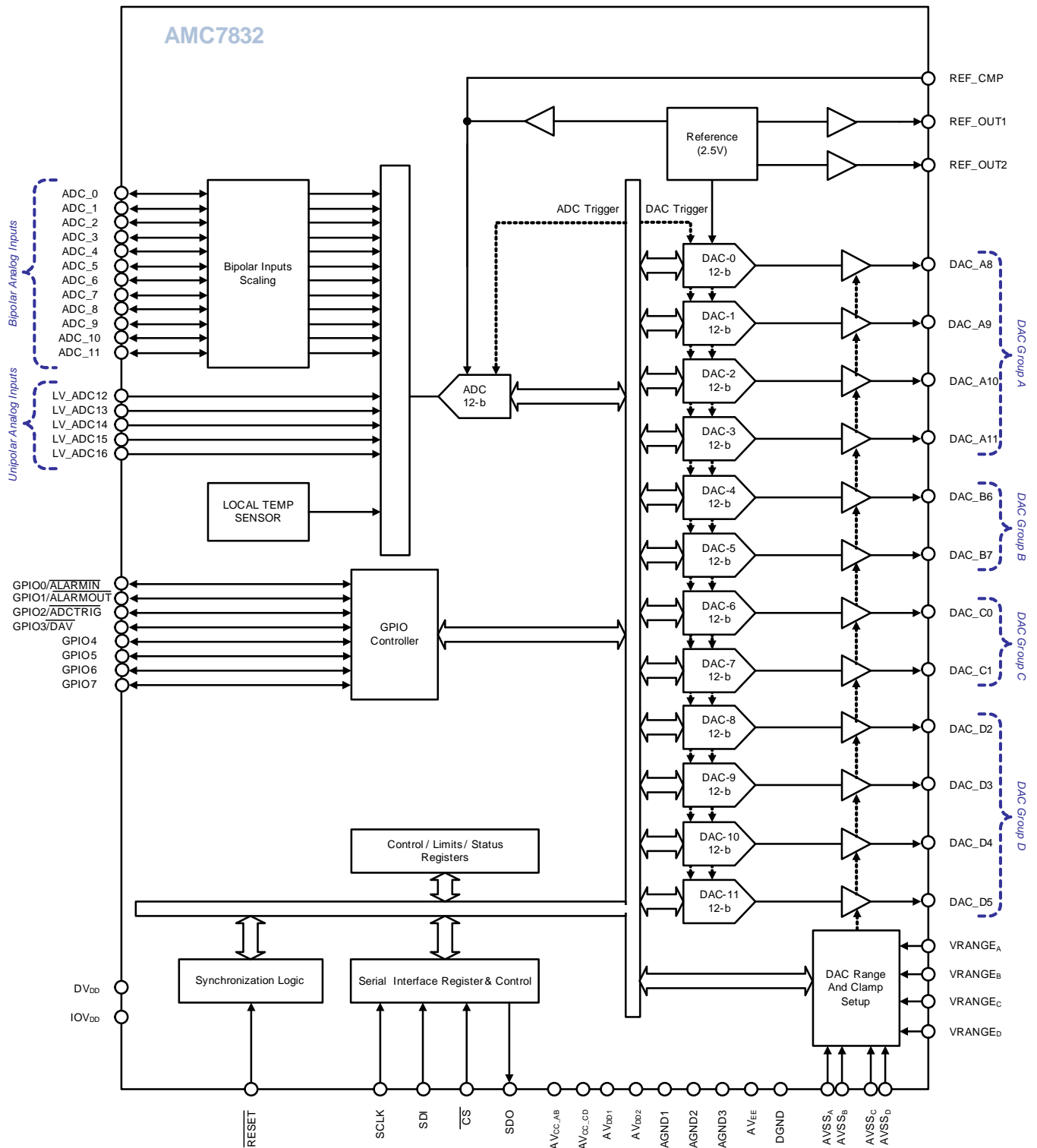

8.3 Feature Description

8.3.1 Digital-to-Analog Converters (DACs)

The AMC7832 features an analog control system centered on twelve, 12-bit DACs that operate from the device internal reference. Each DAC core consists of a string DAC and output voltage buffer.

The resistor string structure consists of a series of resistors, each of value R. The code loaded to the DAC determines at which node on the string the voltage is tapped off to be fed into the output amplifier. The voltage is tapped off by closing one of the switches connecting the string to the amplifier. This architecture has inherent monotonicity, voltage output, and low glitch. It is also linear because all the resistors are of equal value.

8.3.1.1 DAC Output Range and Clamp Configuration

The twelve DACs are split into four total groups: two groups of two DACs (DAC groups B and C) and two groups of four DACs (DAC groups A and D). All of the DACs in a given group share the same output range and clamp voltage value however these settings can be set independently for each DAC group. After power-on or a reset event, the DAC output are directed automatically to their corresponding clamp value and all DAC buffer and active registers are set to their default values.

The output range for each DAC group is configured as either positive or negative through its corresponding VRANGE terminal. The VRANGE terminals can be driven directly by the REF_OUT1 and REF_OUT2 +2.5-V outputs. When a DAC group is in positive output range the DAC Range register (address 0x1E) can be set to specify an output range of 0 to +5-V instead of the default range of 0 to +10-V.

Additionally the power-on-reset and clamp voltage value of each DAC group is set by its corresponding AVSS terminal. It is imperative that the clamp voltage setting for a DAC group matches its operating voltage range. The recommended connections for AVSS are: AGND for the positive output ranges, in which case the clamp voltage is 0-V; and -12-V for the negative output range, in which case the clamp voltage is AVSS + 2-V.

The full-scale output range for each DAC group is limited by the power supplies AVCC and its corresponding AVSS. The maximum and minimum outputs cannot exceed AVCC or be lower than AVSS, respectively.

Table 1. DAC Group Configuration

DAC GROUP	DACs	OUTPUT POLARITY SELECTION	CLAMP VOLTAGE SELECTION	POSITIVE OUTPUT RANGE VRANGE = GND		NEGATIVE OUTPUT RANGE VRANGE = +2.5-V	
				OUTPUT RANGE	VALID CLAMP VOLTAGE CONNECTION	OUTPUT RANGE	VALID CLAMP VOLTAGE CONNECTION
A	DAC_A8 DAC_A9 DAC_A10 DAC_A11	VRANGE _A	AVSS _A	0 to +5-V 0 to +10-V	GND	-10 to 0-V	-12-V
B	DAC_B6 DAC_B7	VRANGE _B	AVSS _B	0 to +5-V 0 to +10-V	GND	-10 to 0-V	-12-V
C	DAC_C0 DAC_C1	VRANGE _C	AVSS _C	0 to +5-V 0 to +10-V	GND	-10 to 0-V	-12-V
D	DAC_D2 DAC_D3 DAC_D4 DAC_D5	VRANGE _D	AVSS _D	0 to +5-V 0 to +10-V	GND	-10 to 0-V	-12-V

8.3.1.2 DAC Register Structure

The DACs input data is written to the individual DAC Data registers (address 0x50 – 0x67) in straight binary format for all output ranges.

Table 2. DAC Data Format

DIGITAL CODE	DAC OUTPUT VOLTAGE (V)		
	0 TO +5-V RANGE	0 TO +10-V RANGE	-10 TO 0-V RANGE
0000 0000 0000	0	0	-10
0000 0000 0001	0.00122	0.00244	-9.99756
1000 0000 0000	2.5	5	-5
1111 1111 1110	4.99756	9.99512	-0.00488
1111 1111 1111	4.99878	9.99756	-0.00244

Data written to the DAC Data registers is initially stored in the DAC buffer registers. Transfer of data from the DAC buffer registers to the active registers is initiated by an update command in the Register Update register (address 0x0F). Once the active registers are updated, the DAC outputs change to their new values.

The host has the option to read from either the buffer registers or the active registers when accessing the DAC Data registers. The DAC read back option is configured by the READBACK bit in the Interface Configuration 1 register (address 0x01).

8.3.1.3 DAC Clear Operation

Each DAC can be set to a clear state using either hardware or software. When a DAC goes to clear state it is loaded with a zero-code input and the output voltage is set according to the operating output range. The DAC buffer or active registers do not change when the DACs enter the clear state thus allowing the possibility to return to the same voltage being output before the clear event was issued. Note that the DAC Data registers can be updated while the DACs are in clear state allowing the DACs to output new values upon return to normal operation. When the DACs exit the clear state they are immediately loaded with the data in the DAC active registers and the output is set back to the corresponding level to restore operation.

The DAC Clear registers (address 0xB0 – 0xB1) enable independent control of each DAC clear state through software. The DACs can also be forced to a clear state through hardware using the $\overline{\text{ALARMIN}}$ terminal. For a detailed description of this method please refer to the Programmable Out-of-Range Alarms section.

The $\overline{\text{ALARMIN}}$ controlled clear mechanism is a special case of the device capability to force the DACs into clear state as a response to an alarm event. To enable this functionality the clear-state controlling alarm events must first be enabled as DAC clear alarm sources in the DAC Clear Source registers (address 0x1A – 0x1B). Additionally the DAC outputs to be cleared by the selected alarm events need also to be specified in the DAC Clear Enable registers (address 0x18 – 0x19).

When an alarm event is triggered, the corresponding alarm bit in the Alarm Status registers is set and all the DACs set to clear in response to this alarm in the DAC Clear Enable registers enter a clear state. Once the alarm bit is cleared, and as long as no other clear-state controlling alarm events have been triggered, the DACs get reloaded with the contents of the DAC active registers and the outputs update accordingly.

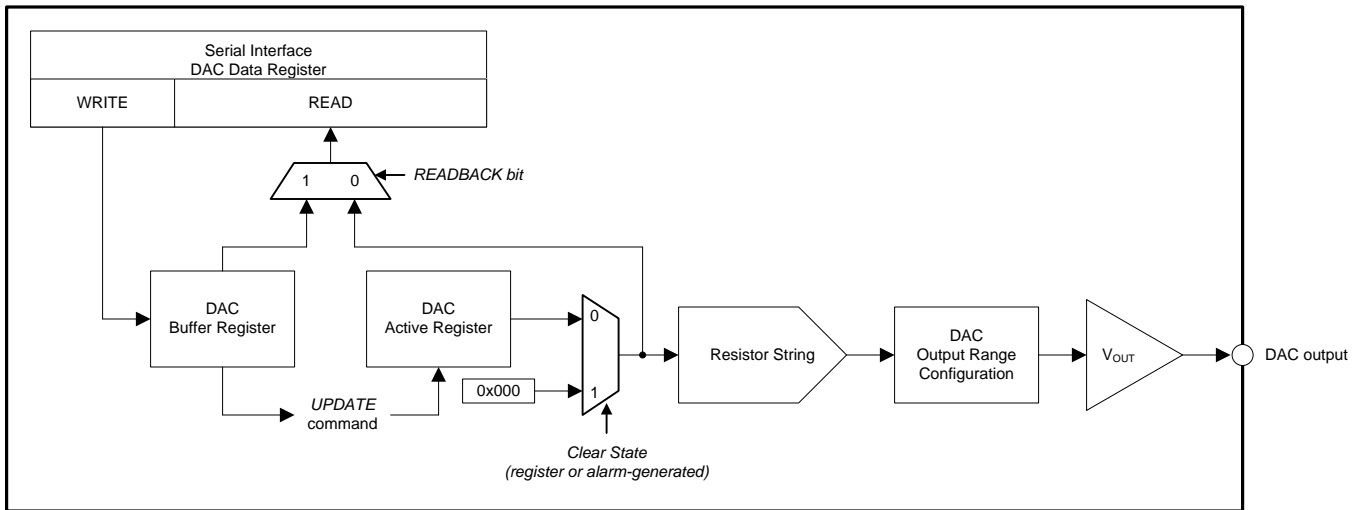

Figure 42. Simplified AMC7832 DAC Block Diagram

8.3.2 Analog-to-Digital Converter (ADC)

The AMC7832 features a monitoring system centered on a 12-bit successive approximation register (SAR) ADC fronted by an 18-channel multiplexer and an on-chip track-and-hold. The monitoring system is capable of sensing up to 12 external bipolar inputs (-12.5-V to +12.5-V range), 5 external unipolar inputs (0 to +5-V range) and an internal analog temperature sensor.

The ADC operates from an internal 2.5-V reference and its input range is 0-V to 2 × VREF. The external bipolar inputs to the ADC are internally mapped to this range. The ADC timing signals are derived from an on-board temperature compensated oscillator. The conversion results can be accessed through the device serial interface.

8.3.2.1 Analog Inputs

The AMC7832 has 17 uncommitted analog inputs for external voltage sensing. Twelve of these inputs (ADC_0 to ADC_11) are bipolar and the other five (LV_ADC12 to LV_ADC16) unipolar. Figure 43 shows the equivalent circuit for the external analog input terminals. All switches are open while the ADC is in idle state.

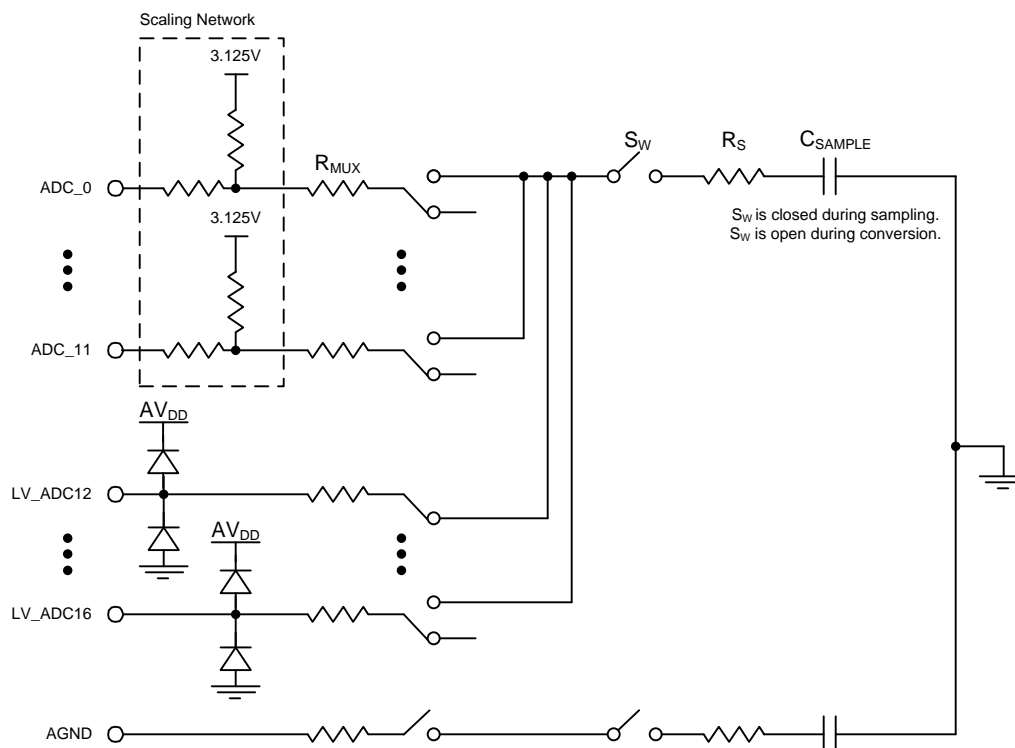

Figure 43. ADC External Inputs Equivalent Circuit

In order to achieve specified performance, especially at higher input frequencies, it is recommended to drive each analog input terminal with a low impedance source. An external amplifier can also be used to drive the input terminals.

8.3.2.1.1 Bipolar Analog Inputs

The AMC7832 supports up to twelve bipolar analog inputs. The analog input range for these channels is -12.5-V to +12.5-V. The bipolar signal is scaled internally through a resistor divider so that it maps to the native input range of the ADC (0-V to 2 × VREF). The input resistance of the scaling network is 175-kΩ.

The bipolar analog input conversion values are stored in straight binary format in the ADC-Data registers (address 0x20 – 0x37). The LSB size for these channels is 10 × VREF/4096. With the internal reference equal to 2.5-V the voltage value is given by,

$$\text{Voltage} = 5 \left[\frac{\text{CODE} \times 5}{4096} - 2.5 \right] \quad (1)$$

A typical application for the bipolar channels is monitoring of the twelve DAC outputs in the device. In this application the bipolar inputs can be driven directly. However in applications where the signal source has high impedance, it is recommended that the analog input is buffered prior to be input to the AMC7832. When driven from a low impedance source such as the AMC7832 DAC outputs, the network is designed to settle well before the start of conversion. Additional impedance may affect the settling and divider accuracy of this network.

8.3.2.1.2 Unipolar Analog Inputs

In addition to the bipolar input channels, the AMC7832 includes five unipolar analog inputs. The analog input range for these channels is 0-V to 2 × VREF with the LSB size for these channels given by 2 × VREF/4096.

The unipolar analog input conversion values are stored in straight binary format in the ADC-Data registers (address 0x38 – 0x41). With the internal reference equal to 2.5-V the voltage value is given by,

$$\text{Voltage} = \frac{\text{CODE} \times 5}{4096} \quad (2)$$

In applications where the signal source has high impedance, it is recommended that the unipolar analog input is buffered externally.

8.3.2.2 ADC Sequencing

The AMC7832 ADC supports two conversion methods: direct-mode and auto-mode. The conversion method can be selected in the ADC Configuration register (address 0x10). The default conversion method is direct-mode.

In both methods, the single channel or sequence of channels to be converted by the ADC must be first configured in the ADC MUX Configuration registers (address 0x13 – 0x15). The input channels to the ADC include 12 external bipolar inputs, 5 external unipolar inputs and the internal temperature sensor.

In direct-mode conversion, the selected ADC input channels are converted on demand by issuing an ADC trigger signal. After the last enabled channel is converted, the ADC goes into idle state and waits for a new trigger.

In auto-mode conversion, the selected ADC input channels are converted continuously. The conversion cycle is initiated by issuing an ADC trigger. Upon completion of the first conversion sequence another sequence is automatically started. Conversion of the selected channels is done repeatedly until the auto-mode conversion is stopped by issuing a second trigger signal. To ensure data for all channels is updated correctly in the ADC data registers the auto-mode conversion stop trigger should be synchronized with the data available indicator signal (DAV, terminal 12).

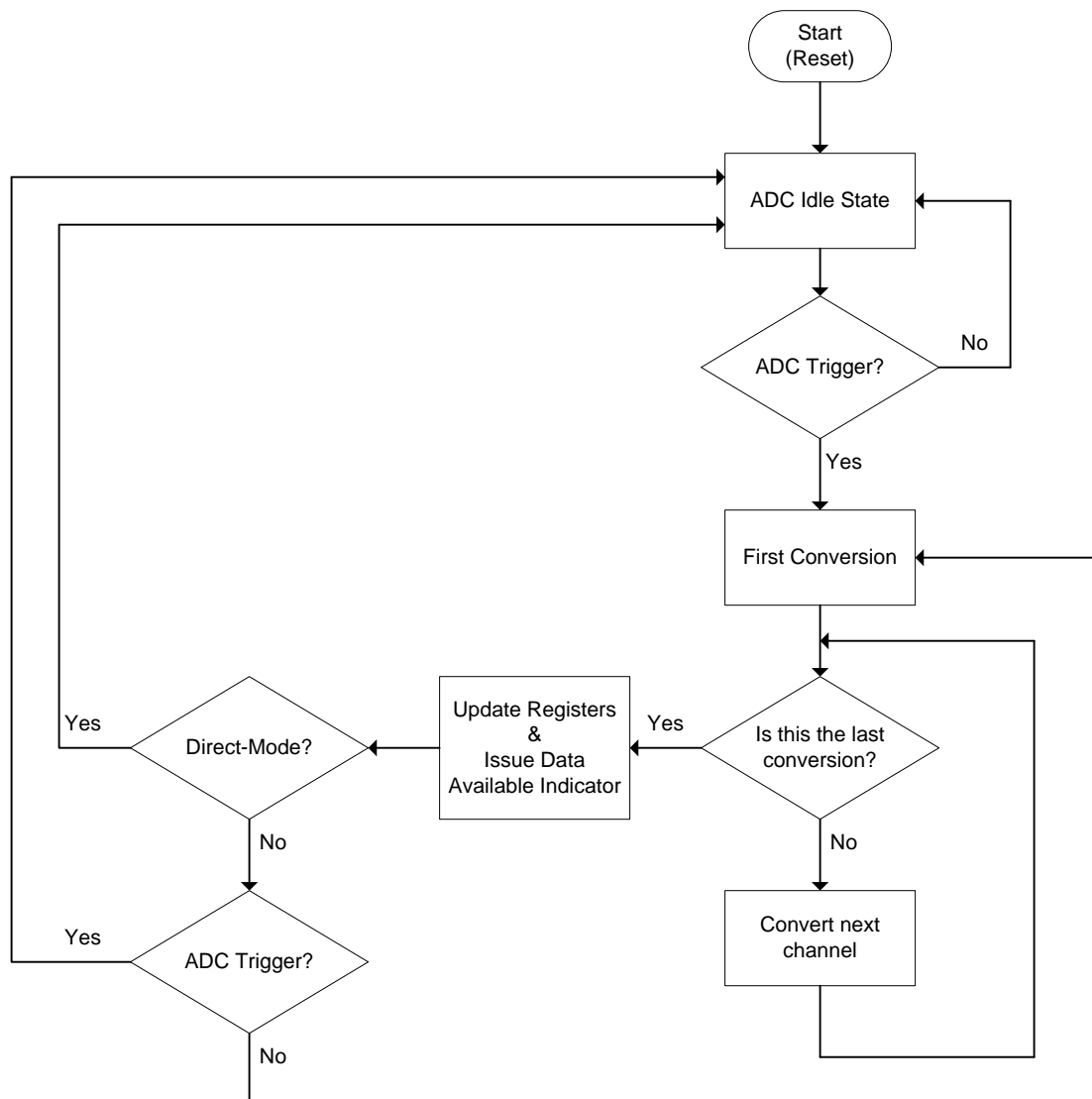

Figure 44. AMC7832 ADC Conversion Sequence

Regardless of the selected conversion method, the following registers should only be updated while the ADC is in idle state:

- ADC Configuration Register (address 0x10)
- False Alarm Configuration Register (address 0x11)
- ADC MUX Configuration Registers (address 0x13 – 0x15)
- Threshold Registers (0x80 – 0x97)
- Hysteresis Register (0xA0 – 0xA5)
- Power Down Registers (0xB2 - 0xB3)

8.3.2.3 ADC Synchronization

A trigger signal is required for getting the ADC in and out of idle state. The ADC trigger can be generated either through software (ICONV bit in the ADC Trigger Register, 0xC0) or hardware (GPIO2/ADCTRIG, terminal 11). In order to use the GPIO2/ADCTRIG terminal as an ADC trigger, the terminal must be configured accordingly in the GPIO Configuration register (address 0x12). When the terminal is configured as a trigger, a falling edge starts the sampling and conversion of the ADC.

The ADC Data registers (0x20 – 0x41) and Temperature Data registers (0x78 – 0x79) should only be accessed while the ADC is in idle state or between conversion sequences if the ADC is in auto-mode. A data available indicator signal is generated by the device to track the ADC status. Failure to satisfy the synchronization requirements could lead to erroneous data reads.

The data available indicator signal is output through the GPIO3/ $\overline{\text{DAV}}$ terminal. The GPIO3/ $\overline{\text{DAV}}$ terminal must be configured in the GPIO Configuration register (address 0x12) as an interrupt. In addition to the terminal indicator the device provides a data available flag accessible through the serial interface (DAVF bit in the General Status Register, 0x72). The $\overline{\text{DAV}}$ terminal is available in both auto and direct-mode but the DAVF flag is only available in direct mode.

The terminal and flag behavior are dependent on the conversion mode. In direct-mode, after the conversion is completed and the ADC returns to idle state, the DAVF bit is set immediately to '1' and the $\overline{\text{DAV}}$ terminal is active (low) to indicate new data is available. The terminal and flag are cleared automatically once a new conversion is started or one of the ADC Data or Temperature Data registers is accessed. In auto-mode, the DAVF bit is fixed to '0' and therefore synchronization is always done through the $\overline{\text{DAV}}$ terminal. After one auto-mode conversion sequence is complete a 1 μs pulse (low) is issued on the $\overline{\text{DAV}}$ terminal. When an auto-mode conversion needs to be stopped it is recommended to do so in synchronization with $\overline{\text{DAV}}$.

a) Direct-Mode, software trigger

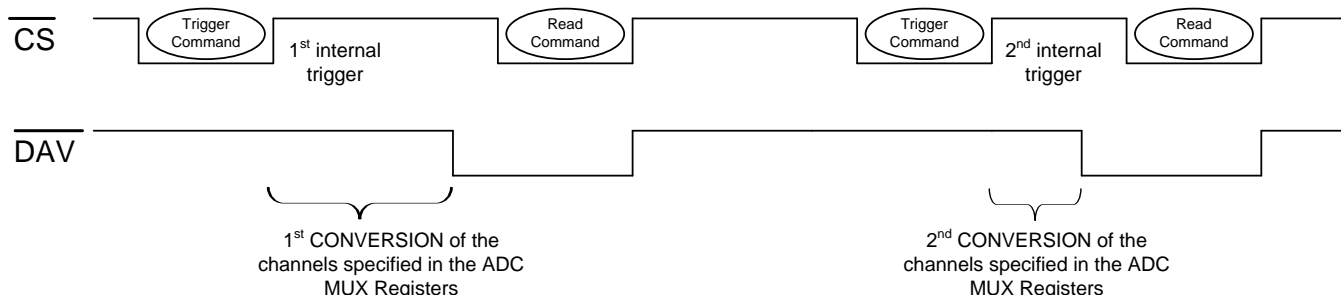

b) Auto-Mode, software trigger

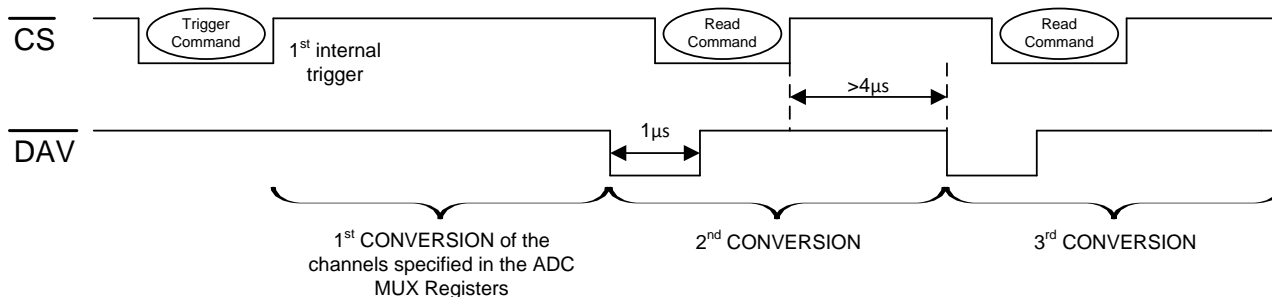
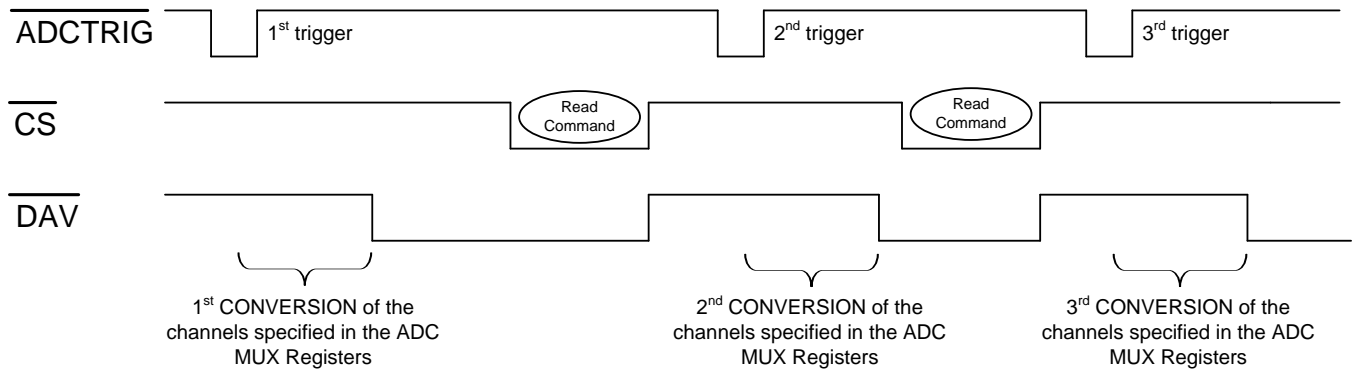

Figure 45. ADC Software Trigger Synchronization

a) Direct-Mode, hardware trigger



b) Auto-Mode, hardware trigger

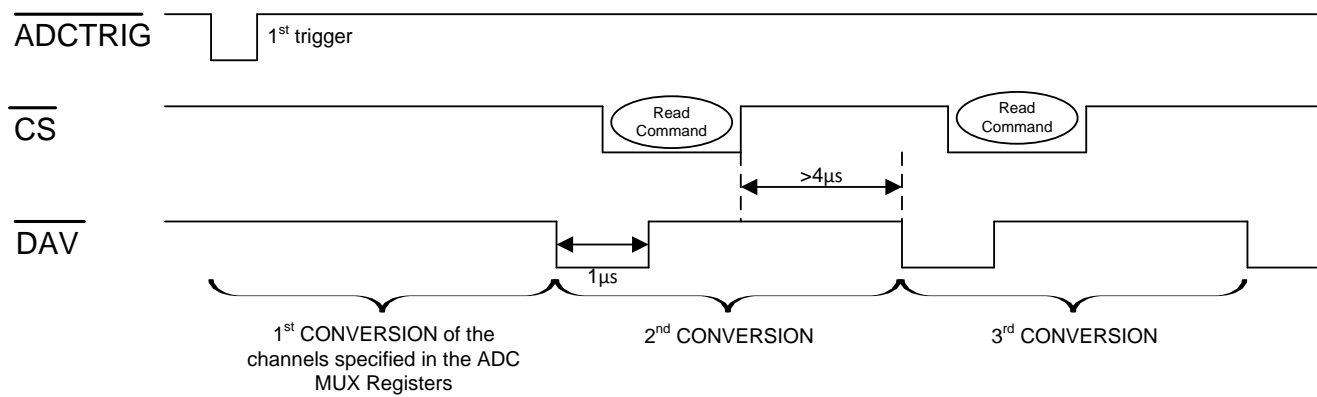

Figure 46. ADC Hardware Trigger Synchronization

8.3.2.4 Programmable Out-of-Range Alarms

The AMC7832 is capable of continuously analyzing the 5 external unipolar inputs and internal temperature sensor conversion results for normal operation.

Normal operation is established through the Lower and Upper Threshold registers (address 0x80 – 0x97). When any of the monitored inputs is out of the specified range, an alarm event is issued and the global alarm bit, GALR in the General Status register (0x72) is set. Details on the source of the alarm event can be determined through the Alarm Status registers (0x70 – 0x71).

The ALARM-LATCH-DIS bit in the $\overline{\text{ALARMOUT}}$ Source 1 register (address 0x1D) sets the latching behavior for all alarms (except for the $\overline{\text{ALARMIN}}$ alarm which is always unlatched). When the ALARM-LATCH-DIS bit is cleared to '0' the alarm bits in the Alarm Status registers are latched. The alarm bits are referred to as being latched because they remain set until read by software. This design ensures that out-of-limit events cannot be missed if the software is polling the device periodically. The alarm bits are cleared when their corresponding Alarm Status register is read, and are reasserted if the out-of limit condition still exists on the next monitoring cycle, unless otherwise noted. When the ALARM-LATCH-DIS bit is set to '1', the alarm bits are not latched. The alarm bits in the Alarm Status registers go to '0' when the error condition subsides, regardless of whether the bit is read or not.

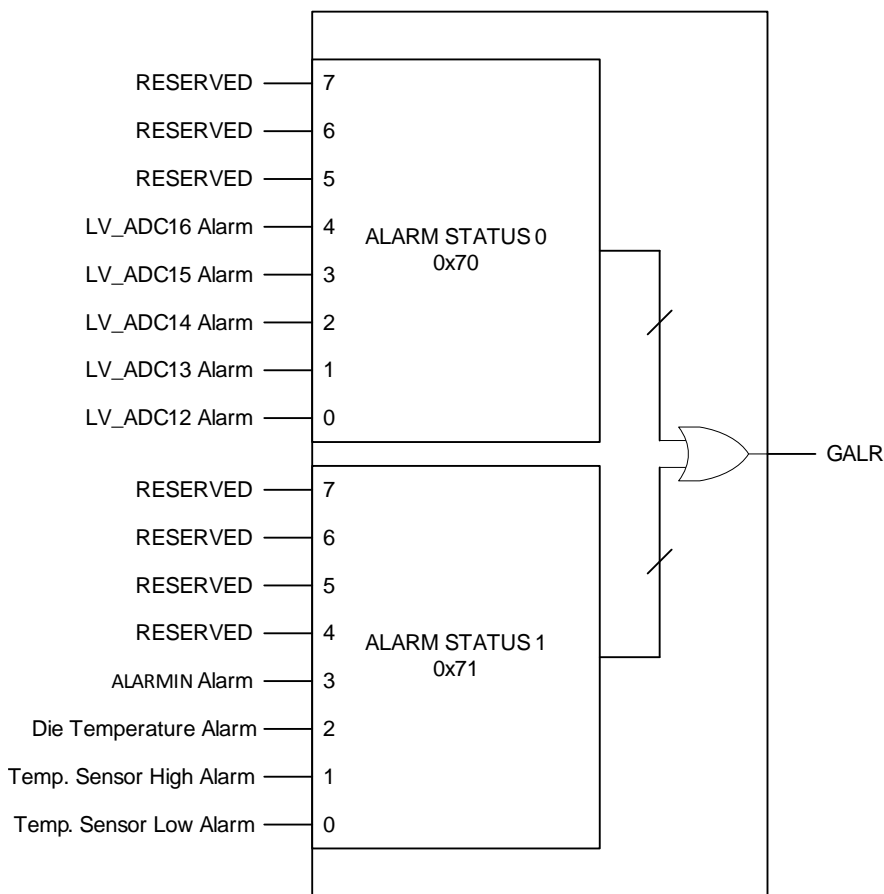

Figure 47. AMC7832 Alarm Status Register

All of the alarms can be set to activate the $\overline{\text{ALARMOUT}}$ terminal. The GPIO1/ $\overline{\text{ALARMOUT}}$ terminal must be configured accordingly in the GPIO Configuration register (address 0x12) to enable this functionality. The $\overline{\text{ALARMOUT}}$ terminal works as an interrupt to the host so that it may query the Alarm Status registers to determine the alarm source. Any alarm event can activate the terminal as long as the alarm is not masked in the $\overline{\text{ALARMOUT}}$ Source registers (address 0x1C – 0x1D). When an alarm event is masked, the occurrence of the event sets the corresponding status bit in the Alarm Status registers to '1', but does not activate the $\overline{\text{ALARMOUT}}$ terminal.

8.3.2.4.1 Unipolar Inputs Out-of-Range Alarms

The AMC7832 provides out-of-range detection for the five external unipolar ADC inputs (LV_ADC12 to LV_ADC16, terminals 41 - 45). When the measurement is out-of-range, the corresponding alarm bit in the Alarm Status 0 register (address 0x70) is set to '1' to flag the out-of-range condition. The values in the ADC Upper and Lower Threshold registers (address 0x80 – 0x93) define the upper and lower bound thresholds for all five inputs.

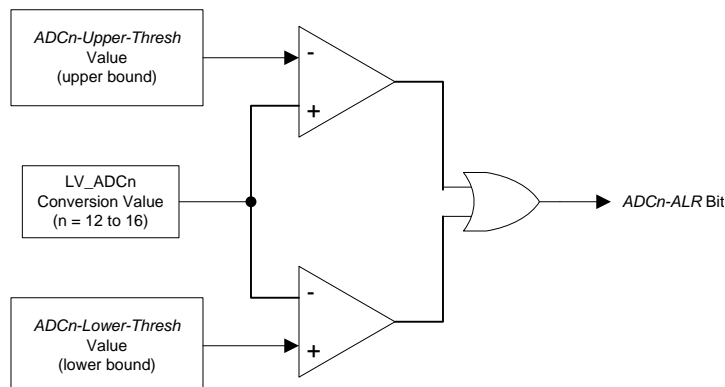

Figure 48. Unipolar Inputs Out-of-Range Alarms

8.3.2.4.2 Internal Temperature Sensor Out-of-Range Alarms

The AMC7832 includes high-limit and low-limit detection for the internal temperature sensor. The values in the LT Upper and Lower Threshold registers (address 0x94 – 0x97) set the limits for the temperature sensor. The temperature sensor detector can issue either a high-alarm (LT-HIGH-ALR bit) or a low-alarm (LT-LOW-ALR bit) in the Alarm Status 1 register (address 0x71) depending on whether the high or low thresholds were exceeded. To implement single, upper-bound threshold detection for the temperature sensor, the host processor can set the upper-bound threshold to the desired value and the lower-bound threshold to the default value. For lower-bound threshold detection, the host processor can set the lower-bound threshold to the desired value and the upper-bound threshold to the default value.

In addition to the programmable threshold alarms the temperature sensor detection circuit also includes a die thermal alarm flag which continuously monitors the die temperature. When the die temperatures exceeds +150°C the die thermal alarm flag (THERM-ALR bit) in the Alarm Status 1 register (address 0x71) is set. The internal temperature sensor must be enabled for this alarm to be functional.

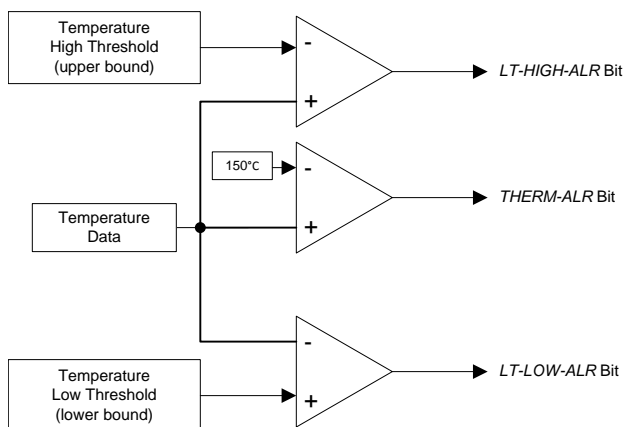

Figure 49. Internal Temperature Out-of-Range Alarms

8.3.2.4.3 $\overline{\text{ALARMIN}}$ Alarm

The AMC7832 offers the option of using an external interrupt signal, such as the output of a comparator as an alarm event. The GPIO0/ $\overline{\text{ALARMIN}}$ terminal is used as the alarm input and must be configured accordingly in the GPIO Configuration register (address 0x12). When the terminal is configured as an alarm input it is active low.

A typical application for $\overline{\text{ALARMIN}}$ is to use it as a hardware interrupt responsible for forcing one or more DACs to a clear state: the DAC is loaded with a zero-code input and the output voltage is set accordingly to the operating output range, however the DAC buffer or active registers do not change (refer to the DAC section for more details). To enable this functionality $\overline{\text{ALARMIN}}$ must be enabled as a DAC clear alarm source in the DAC Clear Source 1 register (address 0x1B). Additionally the DAC outputs to be cleared by the $\overline{\text{ALARMIN}}$ terminal need to be specified in the DAC Clear Enable registers (address 0x18 – 0x19).

In this application when the $\overline{\text{ALARMIN}}$ terminal goes low, all the DACs set to clear in response to the $\overline{\text{ALARMIN}}$ alarm in the DAC Clear Enable registers enter a clear state. When the $\overline{\text{ALARMIN}}$ terminal goes back high the DACs get re-loaded with the contents of the DAC active registers thus allowing the DAC outputs to return to their previous operating point without any additional commands.

8.3.2.4.4 Hysteresis

If a monitored signal is out of range and the alarm is enabled, the corresponding alarm bit is set ('1'). However, the alarm condition is cleared only when the conversion result returns to a value of at least HYST below the value of the high threshold register, or HYST above the value of the low threshold register. The ADC and LT Hysteresis registers (address 0xA0 – 0xA4) store the hys value for the external unipolar inputs and internal temperature sensor programmable alarms. HYST is the programmable value of hysteresis: 0 LSB to 127 LSB for the unipolar inputs alarms, and 0°C to +31°C for the internal temperature sensor alarms. The die thermal alarm hysteresis is fixed at 8°C.

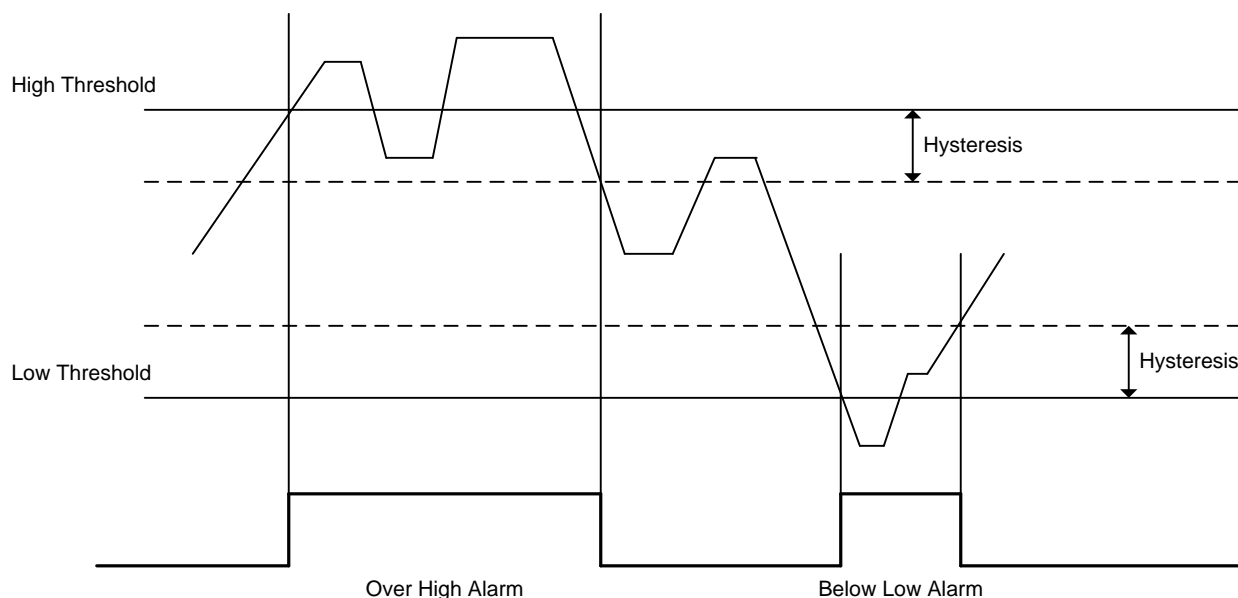

Figure 50. AMC7832 Hysteresis

8.3.2.4.5 False-Alarm Protection

In order to prevent false alarms an alarm event is only registered when the monitored signal is out of range for an N number of consecutive conversions. If the monitored signal returns to the normal range before N consecutive conversions, an alarm event is not issued. The false alarm factor N for the unipolar input and local temperature sensor out-of-range alarms can be configured in the False Alarm Configuration register (address 0x11).

8.3.3 Internal Temperature Sensor

The AMC7832 has an on-chip temperature sensor used to measure the device die temperature. The normal operating temperature range for the internal temperature sensor is limited by the operating temperature range of the device (–40°C to +125°C).

The temperature sensor results are converted by the device ADC at a lower speed than the analog input channels. Temperature can be monitored either continuously or as a single-time conversion depending on whether the ADC is configured in Auto mode or Direct mode (refer to the ADC section for more details). If the temperature sensor is not needed, it can be disabled in the ADC MUX Configuration 2 register (address 0x15). By default the temperature sensor is disabled and not converted by the ADC.

The temperature sensor gives 0.25°C resolution over the operating temperature range. The temperature value is stored in 12-bit two's complement format in the Temperature data registers (address 0x78 – 0x79).

Table 3. Temperature Sensor Data Format

TEMPERATURE (°C)	DIGITAL CODE
-40	1111 0110 0000
-25	1111 1001 1100
-10	1111 1101 1000
-0.25	1111 1111 1111
0	0000 0000 0000
+0.25	0000 0000 0001
+10	0000 0010 1000
+25	0000 0110 0100
+50	0000 1100 1000
+75	0001 0010 1100
+100	0001 1001 0000
+105	0001 1010 0100
+125	0001 1111 0100

If the output data MSB is '0', the temperature can be calculated by,

$$\text{Positive Temperature (°C)} = \frac{\text{ADC_Code}}{4} \quad (3)$$

$$\text{Negative Temperature (°C)} = \frac{4096 - \text{ADC_Code}}{4} \quad (4)$$

8.3.4 Internal Reference

The AMC7832 includes a high performance internal reference for the on-chip ADC and twelve DACs. The internal reference is a 2.5-V bipolar transistor-based, precision bandgap reference. A compensation capacitor (4.7- μ F, typical) should be connected between the REF_CMP terminal and AGND2.

The AMC7832 includes two buffers to access the internal reference voltage through terminals REF_OUT1 and REF_OUT2. If unused, the two reference buffers can be powered down independently in the Power-down 1 register (address 0xB3). A third buffer is used to drive the ADC and should not be used to drive any external circuitry. The ADC reference buffer is powered down by default and should be enabled in the ADC Configuration Register (address 0x10) during device initialization.

The REF_OUT1 and REF_OUT2 outputs can directly drive the VRANGE_{A,B,C,D} inputs thus enabling adjustment of the DAC output ranges without the need for external circuitry. The internal reference buffers are not intended to drive external loads. If driving an external load, a high impedance buffer amplifier is required.

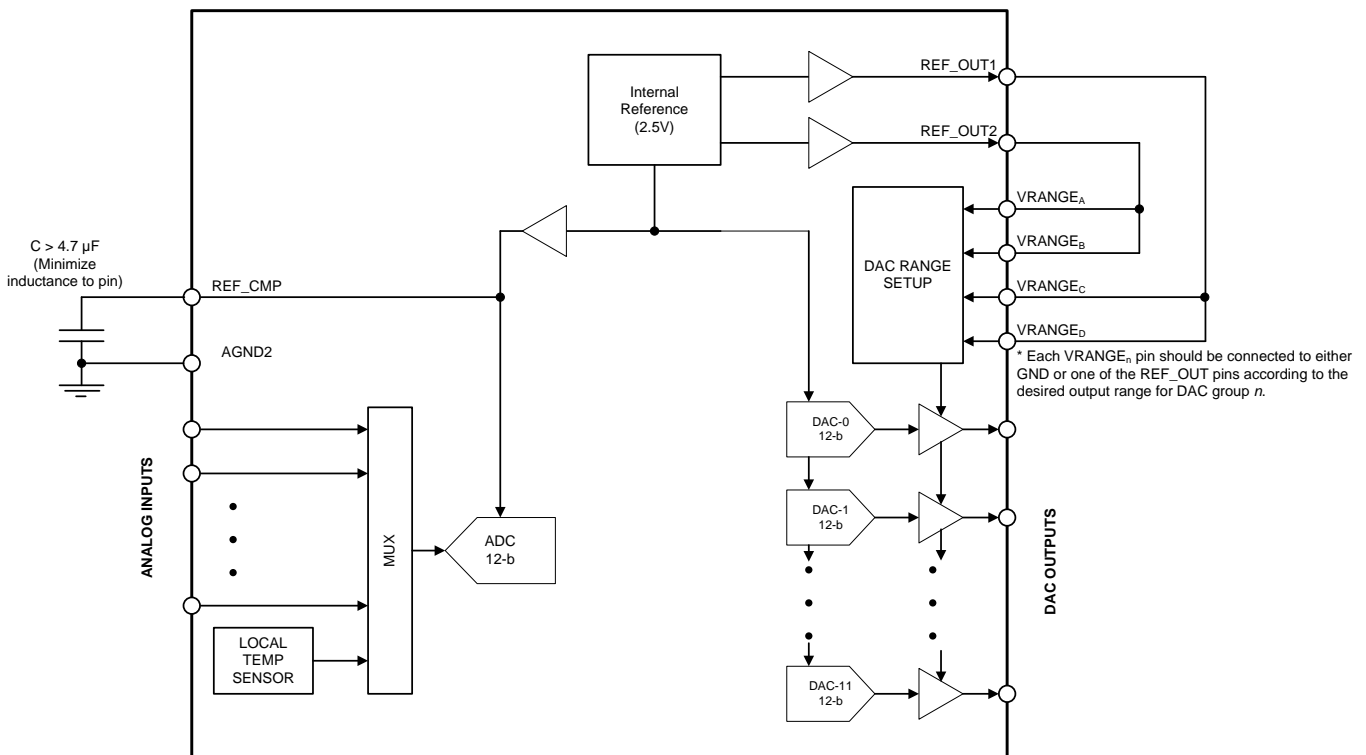

Figure 51. AMC7832 Internal Reference

8.3.5 General Purpose I/Os

The AMC7832 includes eight General Purpose I/O (GPIO) terminals, each with an internal 48-k Ω pull-up resistor to IOV_{DD}. The GPIO[0-3] terminals have dual functionality and can be programmed as either bidirectional digital I/O terminals or interrupt signals in the GPIO Configuration register (address 0x12). The GPIO[4-7] terminals are dedicated GPIOs.

Table 4. Dual Functionality GPIO Pins

PIN	DEFAULT PIN NAME	ALTERNATIVE PIN NAME	ALTERNATIVE FUNCTIONALITY
9	GPIO0	$\overline{\text{ALARMIN}}$	DAC clear control signal.
10	GPIO1	$\overline{\text{ALARMOUT}}$	Global alarm output.
11	GPIO2	$\overline{\text{ADCTRIG}}$	External ADC conversion trigger.
12	GPIO3	$\overline{\text{DAV}}$	ADC data available indicator.

The GPIOs can receive an input or produce an output. When the GPIO acts as an output its status is determined by the corresponding GPIO bit in the GPIO Register (address 0x7A).

To use a GPIO terminal as an input, the corresponding GPIO bit in the GPIO Register must be set to '1'. When a GPIO terminal acts as input, the digital value on the terminal is acquired by reading the corresponding GPIO bit. After a power-on reset or any forced reset, all GPIO bits are set to '1', and the GPIO terminals have a 48-k Ω input impedance to IOV_{DD}.

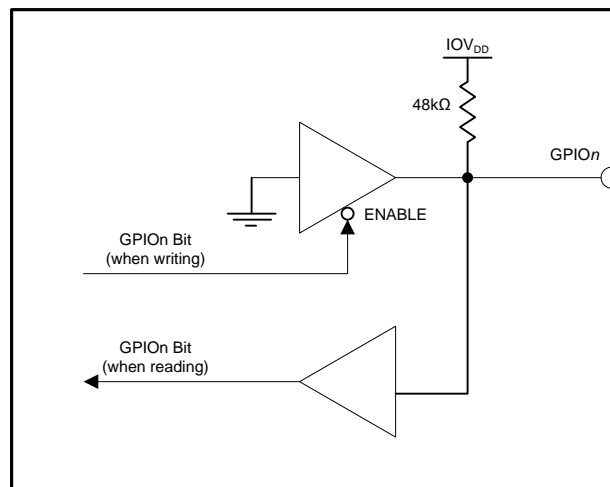

Figure 52. AMC7832 GPIO Pin

8.4 Programming

The AMC7832 is controlled through a flexible four-wire serial interface that is compatible with SPI type interfaces used on many microcontrollers and DSP controllers. The interface provides read/write access to all registers of the AMC7832.

Each serial interface access cycle is exactly (N+2) bytes long, where N is the number of data bytes. A frame is initiated by asserting \overline{CS} low. The frame ends when \overline{CS} is deasserted high. In MSB first mode, the first bit transferred is the R/W bit. The next 15 bits are the register address (32768 addressable registers), and the remaining bits are data. For all writes, data is committed in bytes as the 8th data bit of a data field is clocked in on the rising edge of SCLK. If the write access is not a multiple of 8 clocks, the trailing data bits will not be committed. On read access, data is clocked out on the falling edge of SCLK on the SDO terminal.

The figures below show the access protocol used by the interface. Data is by default accepted as MSB (Most Significant Bit) first but the AMC7832 can be configured to accept LSB (Least Significant Bit) first operations as long as the LSB_Order bit in the Interface Configuration 0 register (address 0x00) is set accordingly.

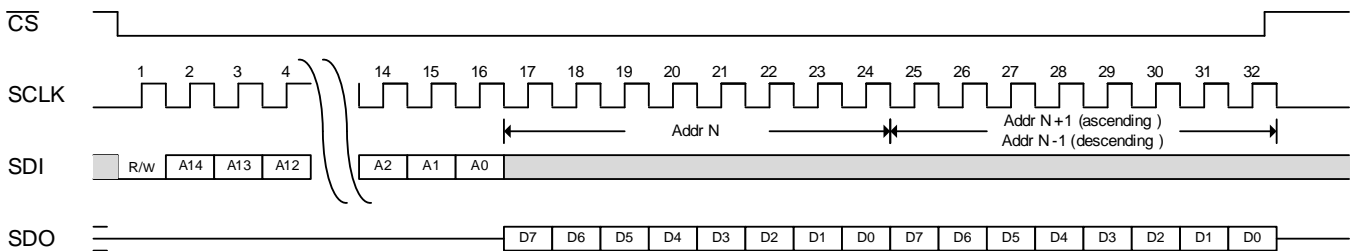

Figure 53. Serial Interface Write Bus Cycle

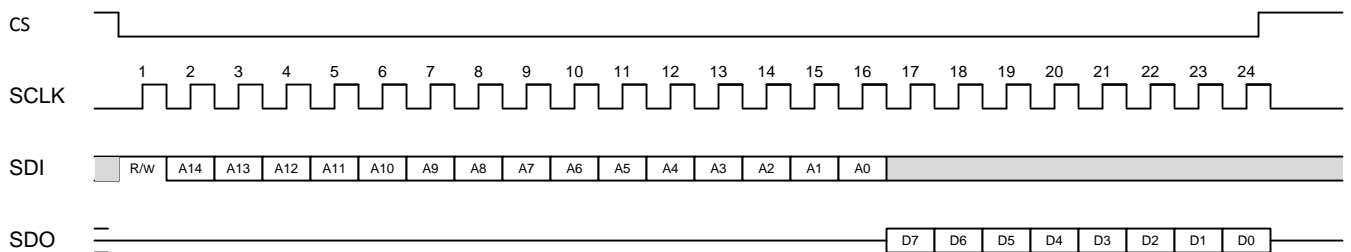

Figure 54. Serial Interface Read Bus Cycle

For operations that require large amounts of data to be passed to or from the AMC7832, streaming mode is supported. In streaming mode multiple bytes of data can be written to or read from the AMC7832 without specifically providing instructions for each byte and is implemented by continually holding the \overline{CS} active and continuing to shift new data in or old data out of the device.

The instruction phase includes the starting address. The AMC7832 starts reading or writing data to this address and continues as long as \overline{CS} is asserted and single byte writes has not been enabled in the Interface Configuration 1 register (address 0x01). The AMC7832 automatically increments or decrements the address depending on the setting of the address ascension bit in the Interface Configuration 0 register (address 0x00).

If the address is decrementing and 0x0000 is reached, the next address used is address 0x7FFF. If the address is incrementing and address 0x7FFF is reached, the next address used is 0x0000. Care should be taken when writing to 0x0000 and 0x0001 as writing to these addresses may change the configuration of the serial interface. Therefore it is advised that 0x0001 be the first address written and that streaming stops prior to reaching this address.

The figures below show the access protocol used in streaming mode.

Programming (continued)

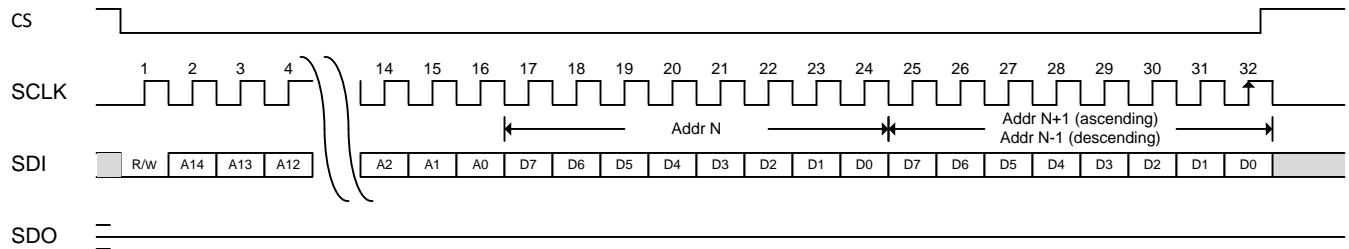

Figure 55. Serial Interface Streaming Write Example

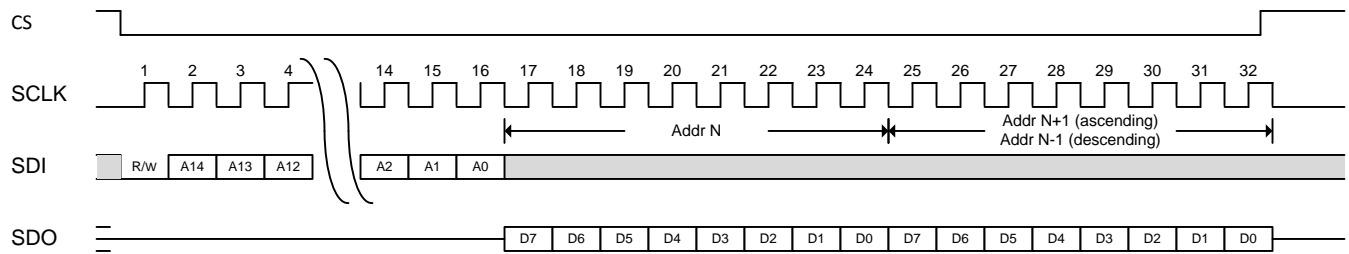

Figure 56. Serial Interface Streaming Read Example

8.5 Register Map

Table 5. Register Map

ADDRESS (HEX)	R/W	DEFAULT (HEX)	REGISTER	ADDRESS (HEX)	R/W	DEFAULT (HEX)	REGISTER
0x00	R/W	3C	Interface Configuration 0	0x54	R/W	00	DACA10-Data (low byte)
0x01	R/W	00	Interface Configuration 1	0x55	R/W	00	DACA10-Data (high byte)
0x02	R/W	03	Device Configuration	0x56	R/W	00	DACA11-Data (low byte)
0x03	R	08	Chip Type	0x57	R/W	00	DACA11-Data (high byte)
0x04	R	32	Chip ID (low byte)	0x58	R/W	00	DACB6-Data (low byte)
0x05	R	0C	Chip ID (high byte)	0x59	R/W	00	DACB6-Data (high byte)
0x06	R	00	Chip Version	0x5A	R/W	00	DACB7-Data (low byte)
0x07 – 0x0B	—	—	Reserved	0x5B	R/W	00	DACB7-Data (high byte)
0x0C	R	51	Manufacturer ID (low byte)	0x5C	R/W	00	DACC0-Data (low byte)
0x0D	R	04	Manufacturer ID (high byte)	0x5D	R/W	00	DACC0-Data (high byte)
0x0E	—	—	Reserved	0x5E	R/W	00	DACC1-Data (low byte)
0x0F	W	00	Register Update	0x5F	R/W	00	DACC1-Data (high byte)
0x10	R/W	00	ADC Configuration	0x60	R/W	00	DACD2-Data (low byte)
0x11	R/W	07	False Alarm Configuration	0x61	R/W	00	DACD2-Data (high byte)
0x12	R/W	00	GPIO Configuration	0x62	R/W	00	DACD3-Data (low byte)
0x13	R/W	00	ADC MUX Configuration 0	0x63	R/W	00	DACD3-Data (high byte)
0x14	R/W	00	ADC MUX Configuration 1	0x64	R/W	00	DACD4-Data (low byte)
0x15	R/W	00	ADC MUX Configuration 2	0x65	R/W	00	DACD4-Data (high byte)
0x16	—	—	Reserved	0x66	R/W	00	DACD5-Data (low byte)
0x17	—	—	Reserved	0x67	R/W	00	DACD5-Data (high byte)
0x18	R/W	00	DAC Clear Enable 0	0x68–0x6F	—	—	Reserved
0x19	R/W	00	DAC Clear Enable 1	0x70	R	00	Alarm Status 0
0x1A	R/W	00	DAC Clear Source 0	0x71	R	00	Alarm Status 1
0x1B	R/W	00	DAC Clear Source 1	0x72	R	00	General Status
0x1C	R/W	00	ALARMOUT Source 0	0x73–0x77	R/W	00	Reserved
0x1D	R/W	00	ALARMOUT Source 1	0x78	R	00	Temperature Data (low byte)
0x1E	R/W	00	DAC Range	0x79	R	00	Temperature Data (high byte)
0x1F	—	—	Reserved	0x7A	R/W	FF	GPIO
0x20	R	00	ADC0-Data (low byte)	0x7B–0x7F	—	—	Reserved
0x21	R	00	ADC0-Data (high byte)	0x80	R/W	FF	ADC12-Upper-Thresh (low byte)
0x22	R	00	ADC1-Data (low byte)	0x81	R/W	0F	ADC12-Upper-Thresh (high byte)
0x23	R	00	ADC1-Data (high byte)	0x82	R/W	00	ADC12-Lower-Thresh (low byte)
0x24	R	00	ADC2-Data (low byte)	0x83	R/W	00	ADC12-Lower-Thresh (high byte)
0x25	R	00	ADC2-Data (high byte)	0x84	R/W	FF	ADC13-Upper-Thresh (low byte)
0x26	R	00	ADC3-Data (low byte)	0x85	R/W	0F	ADC13-Upper-Thresh (high byte)
0x27	R	00	ADC3-Data (high byte)	0x86	R/W	00	ADC13-Lower-Thresh (low byte)
0x28	R	00	ADC4-Data (low byte)	0x87	R/W	00	ADC13-Lower-Thresh (high byte)
0x29	R	00	ADC4-Data (high byte)	0x88	R/W	FF	ADC14-Upper-Thresh (low byte)
0x2A	R	00	ADC5-Data (low byte)	0x89	R/W	0F	ADC14-Upper-Thresh (high byte)
0x2B	R	00	ADC5-Data (high byte)	0x8A	R/W	00	ADC14-Lower-Thresh (low byte)
0x2C	R	00	ADC6-Data (low byte)	0x8B	R/W	00	ADC14-Lower-Thresh (high byte)
0x2D	R	00	ADC6-Data (high byte)	0x8C	R/W	FF	ADC15-Upper-Thresh (low byte)
0x2E	R	00	ADC7-Data (low byte)	0x8D	R/W	0F	ADC15-Upper-Thresh (high byte)
0x2F	R	00	ADC7-Data (high byte)	0x8E	R/W	00	ADC15-Lower-Thresh (low byte)
0x30	R	00	ADC8-Data (low byte)	0x8F	R/W	00	ADC15-Lower-Thresh (high byte)
0x31	R	00	ADC8-Data (high byte)	0x90	R/W	FF	ADC16-Upper-Thresh (low byte)
0x32	R	00	ADC9-Data (low byte)	0x91	R/W	0F	ADC16-Upper-Thresh (high byte)
0x33	R	00	ADC9-Data (high byte)	0x92	R/W	00	ADC16-Lower-Thresh (low byte)
0x34	R	00	ADC10-Data (low byte)	0x93	R/W	00	ADC16-Lower-Thresh (high byte)

Register Map (continued)
Table 5. Register Map (continued)

ADDRESS (HEX)	R/W	DEFAULT (HEX)	REGISTER	ADDRESS (HEX)	R/W	DEFAULT (HEX)	REGISTER
0x35	R	00	ADC10-Data (high byte)	0x94	R/W	FF	LT-Upper-Thresh (low byte)
0x36	R	00	ADC11-Data (low byte)	0x95	R/W	07	LT-Upper-Thresh (high byte)
0x37	R	00	ADC11-Data (high byte)	0x96	R/W	00	LT-Lower-Thresh (low byte)
0x38	R	00	ADC12-Data (low byte)	0x97	R/W	08	LT-Lower-Thresh (high byte)
0x39	R	00	ADC12-Data (high byte)	0x98–0x9F	—	—	Reserved
0x3A	R	00	ADC13-Data (low byte)	0xA0	R/W	08	ADC12-Hysteresis
0x3B	R	00	ADC13-Data (high byte)	0xA1	R/W	08	ADC13-Hysteresis
0x3C	R	00	ADC14-Data (low byte)	0xA2	R/W	08	ADC14-Hysteresis
0x3D	R	00	ADC14-Data (high byte)	0xA3	R/W	08	ADC15-Hysteresis
0x3E	R	00	ADC15-Data (low byte)	0xA4	R/W	08	ADC16-Hysteresis
0x3F	R	00	ADC15-Data (high byte)	0xA5	R/W	08	LT-Hysteresis
0x40	R	00	ADC16-Data (low byte)	0xA6–0xAF	—	—	Reserved
0x41	R	00	ADC16-Data (high byte)	0xB0	R/W	00	DAC Clear 0
0x42–0x4F	—	—	Reserved	0xB1	R/W	00	DAC Clear 1
0x50	R/W	00	DACA8-Data (low byte)	0xB2	R	00	Power-Down 0
0x51	R/W	00	DACA8-Data (high byte)	0xB3	R/W	00	Power-Down 1
0x52	R/W	00	DACA9-Data (low byte)	0xB4–0xBF	—	—	Reserved
0x53	R/W	00	DACA9-Data (high byte)	0xC0	W	00	ADC Trigger

8.5.1 Interface Configuration: Address 0x00 – 0x02

Table 6. Register name: Interface Configuration 0 – Address: 0x00, Default: 0x3C (READ/WRITE)

REGISTER NAME	ADDRESS	BIT	NAME	DESCRIPTION	DEFAULT VALUE
Interface Config 0	0x00	7	SOFT-RESET	Soft reset (self-clearing) 0: no action 1: reset – resets everything except address 0x00, 0x01	0
		6	LSB-ORDER	LSB First 0: MSB first 1: LSB first	0
		5	ADDR-ASCEND	Address Ascend 0: Descend – decrements address while streaming (address wrap from 0x0000 to 0x7FFF) 1: Ascend – increments address while streaming (address wrap from 0x7FFF to 0x0000)	1
		4	Reserved	Reserved for factory use	1
		3:0	REVERSE-CONFIG	Bits 3:0 should always mirror bits 7:4 so that it does not matter whether the part is in MSB or LSB first mode. Bits should be set as follows: Bit 0 = Bit 7 Bit 1 = Bit 6 Bit 2 = Bit 5 Bit 3 = Bit 4	0xC

Table 7. Register name: Interface Configuration 1 – Address: 0x01, Default: 0x00 (READ/WRITE)

REGISTER NAME	ADDRESS	BIT	NAME	DESCRIPTION	DEFAULT VALUE
Interface Config 1	0x01	7	SINGLE-INSTR	Single instruction enable 0: streaming mode (default) 1: single instruction	0
		6	Reserved	Reserved for factory use	0
		5	READBACK	Read back 0: DAC read back from active registers (default) 1: DAC read back from buffer registers	0
		4	Reserved	Reserved for factory use	0
		3	Reserved	Reserved for factory use	0
		2	Reserved	Reserved for factory use	0
		1	Reserved	Reserved for factory use	0
		0	Reserved	Reserved for factory use	0

Table 8. Register name: Device Configuration – Address: 0x02, Default: 0x03 (READ/WRITE)

REGISTER NAME	ADDRESS	BIT	NAME	DESCRIPTION	DEFAULT VALUE
Device Config	0x02	7:2	Reserved	Reserved for factory use	All zeros
		1:0	POWER-MODE	Mode: 00: Normal operation – full power and full performance 11: Sleep – lowest power, non-operational except SPI One time overwrite of the power-down registers (0xB2 and 0xB3)	11

8.5.2 Device Identification: Address 0x03 – 0x0D

Table 9. Register name: Chip Type – Address: 0x03, Default: 0x08 (READ ONLY)

REGISTER NAME	ADDRESS	BIT	NAME	DESCRIPTION	DEFAULT VALUE
Chip Type	0x03	7:4	Reserved	Reserved for factory use	0x0
		3:0	CHIP-TYPE	Identifies the device as a precision analog monitor and control	0x8

Table 10. Register name: Chip ID low byte – Address: 0x04, Default: 0x32 (READ ONLY)

REGISTER NAME	ADDRESS	BIT	NAME	DESCRIPTION	DEFAULT VALUE
Chip ID Low Byte	0x04	7:0	CHIPID-LOW	Chip ID. Low byte	0x32

Table 11. Register name: Chip ID high byte – Address: 0x05, Default: 0x0C (READ ONLY)

REGISTER NAME	ADDRESS	BIT	NAME	DESCRIPTION	DEFAULT VALUE
Chip ID High Byte	0x05	7:0	CHIPID-HIGH	Chip ID. High byte	0x0C

Table 12. Register name: Version ID – Address: 0x06, Default: 0x00 (READ ONLY)

REGISTER NAME	ADDRESS	BIT	NAME	DESCRIPTION	DEFAULT VALUE
Version ID	0x06	7:0	VERSIONID	AMC7832 Version ID. Subject to change.	0x00

Table 13. Register name: Manufacturer ID low byte – Address: 0x0C, Default: 0x51 (READ ONLY)

REGISTER NAME	ADDRESS	BIT	NAME	DESCRIPTION	DEFAULT VALUE
Manuf. ID Low Byte	0x0C	7:0	VENDORID-LOW	Manufacturer ID. Low byte	0x51

Table 14. Register name: Manufacturer ID high byte – Address: 0x0D, Default: 0x04 (READ ONLY)

REGISTER NAME	ADDRESS	BIT	NAME	DESCRIPTION	DEFAULT VALUE
Manuf. ID High Byte	0x0D	7:0	VENDORID-HIGH	Manufacturer ID. High byte	0x04

8.5.3 Register Update (Buffered Registers): Address 0x0F

Table 15. Register name: Register Update – Address: 0x0F, Default: 0x00 (SELF CLEARING)

REGISTER NAME	ADDRESS	BIT	NAME	DESCRIPTION	DEFAULT VALUE
Register Update	0x0F	7:1	Reserved	Reserved for factory use	All zeros
		0	UPDATE	Update (self clearing) 0: disabled 1: enabled – transfers data from buffers to active registers (DAC registers only)	0

8.5.4 General Device Configuration: Address 0x10 – 0x17
Table 16. Register name: ADC Configuration – Address: 0x10, Default: 0x00 (READ/WRITE)

REGISTER NAME	ADDRESS	BIT	NAME	DESCRIPTION	DEFAULT VALUE
ADC Config	0x10	7	CMODE	ADC Conversion Mode Bit. This bit selects the ADC conversion mode. 0: Direct mode. The analog inputs specified in the ADC channel registers are converted sequentially one time. When one set of conversions is complete, the ADC is idle and waits for a new trigger. 1: Auto mode. The analog inputs specified in the AMC channel registers are converted sequentially and repeatedly. When one set of conversions is complete, the ADC multiplexer returns to the first channel and repeats the process. In this mode data should be read synchronously with the \overline{DAV} terminal.	0
		6:5	CONV-RATE[1:0]	ADC Conversion rate bits	00
		4	ADC-REF-BUFF	ADC Reference Buffer bit. This bit must be set to 1 after device power-up to enable the internal reference buffer driving the ADC. 0: ADC reference buffer is disabled. 1: ADC reference buffer is enabled.	0
		3:0	Reserved	Reserved for factory use	0000

Table 17. Register name: False Alarm Configuration – Address: 0x11, Default: 0x70 (READ/WRITE)

REGISTER NAME	ADDRESS	BIT	NAME	DESCRIPTION	DEFAULT VALUE																		
False Alarm Config	0x11	7:5	CH-FALR-CT[2:0]	False alarm protection for ADC channels. <table border="1"> <thead> <tr> <th>CH-FALR-CT</th> <th>N CONSECUTIVE SAMPLES BEFORE ALARM IS SET</th> </tr> </thead> <tbody> <tr><td>000</td><td>1</td></tr> <tr><td>001</td><td>4</td></tr> <tr><td>010</td><td>8</td></tr> <tr><td>011</td><td>16 (default)</td></tr> <tr><td>100</td><td>32</td></tr> <tr><td>101</td><td>64</td></tr> <tr><td>110</td><td>128</td></tr> <tr><td>111</td><td>256</td></tr> </tbody> </table>	CH-FALR-CT	N CONSECUTIVE SAMPLES BEFORE ALARM IS SET	000	1	001	4	010	8	011	16 (default)	100	32	101	64	110	128	111	256	011
		CH-FALR-CT	N CONSECUTIVE SAMPLES BEFORE ALARM IS SET																				
		000	1																				
001	4																						
010	8																						
011	16 (default)																						
100	32																						
101	64																						
110	128																						
111	256																						
4:3	TEMP-FALR-CT[1:0]	False alarm protection for temperature sensor. <table border="1"> <thead> <tr> <th>TEMP-FALR-CT</th> <th>N CONSECUTIVE SAMPLES BEFORE ALARM IS SET</th> </tr> </thead> <tbody> <tr><td>00</td><td>1</td></tr> <tr><td>01</td><td>2</td></tr> <tr><td>10</td><td>4 (default)</td></tr> <tr><td>11</td><td>8</td></tr> </tbody> </table>	TEMP-FALR-CT	N CONSECUTIVE SAMPLES BEFORE ALARM IS SET	00	1	01	2	10	4 (default)	11	8	10										
TEMP-FALR-CT	N CONSECUTIVE SAMPLES BEFORE ALARM IS SET																						
00	1																						
01	2																						
10	4 (default)																						
11	8																						
		2:0	Reserved	Reserved for factory use	000																		

Table 18. Register name: GPIO Configuration – Address: 0x12, Default: 0x00 (READ/WRITE)

REGISTER NAME	ADDRESS	BIT	NAME	DESCRIPTION	DEFAULT VALUE
GPIO Config	0x12	7:5	Reserved	Reserved for factory use	000
		4	Reserved	Reserved for factory use	0
		3	EN-DAV	DAV terminal enable 0: GPIO3 operation (default) 1: DAV operation	0
		2	EN-ADCTRIG	ADCTRIG terminal enable 0: GPIO2 operation (default) 1: ADCTRIG operation	0
		1	EN-ALARMOUT	ALARMOUT terminal enable 0: GPIO1 operation (default) 1: ALARMOUT operation	0
		0	EN-ALARMIN	ALARMIN terminal enable 0: GPIO0 operation (default) 1: ALARMIN operation	0

Table 19. Register name: ADC MUX Configuration 0 – Address: 0x13, Default: 0x00 (READ/WRITE)

REGISTER NAME	ADDRESS	BIT	NAME	DESCRIPTION	DEFAULT VALUE
ADC MUX Config 0	0x13	7	CH7	When set to '1' the corresponding analog input channel ADC_n is accessed during an ADC conversion cycle. When cleared to '0' the corresponding input channel ADC_n is ignored during an ADC conversion cycle.	0
		6	CH6		0
		5	CH5		0
		4	CH4		0
		3	CH3		0
		2	CH2		0
		1	CH1		0
		0	CH0		0

Table 20. Register name: ADC MUX Configuration 1 – Address: 0x14, Default: 0x00 (READ/WRITE)

REGISTER NAME	ADDRESS	BIT	NAME	DESCRIPTION	DEFAULT VALUE
ADC MUX Config 1	0x14	7	CH15	When set to '1' the corresponding analog input channel ADC_n is accessed during an ADC conversion cycle. When cleared to '0' the corresponding input channel ADC_n is ignored during an ADC conversion cycle.	0
		6	CH14		0
		5	CH13		0
		4	CH12		0
		3	CH11		0
		2	CH10		0
		1	CH9		0
		0	CH8		0

Table 21. Register name: ADC MUX Configuration 2 – Address: 0x15, Default: 0x00 (READ/WRITE)

REGISTER NAME	ADDRESS	BIT	NAME	DESCRIPTION	DEFAULT VALUE
ADC MUX Config 2	0x15	7:2	Reserved	Reserved for factory use	All zeros
		1	TEMP-CH	When set to '1' the local temperature sensor is enabled for ADC conversion. When cleared to '0' the local temperature sensor is ignored.	0
		0	CH16	When set to '1' the corresponding analog input channel ADC_n is accessed during an ADC conversion cycle. When cleared to '0' the corresponding input channel ADC_n is ignored during an ADC conversion cycle.	0

Table 22. Register name: DAC Clear Enable 0 – Address: 0x18, Default: 0x00 (READ/WRITE)

REGISTER NAME	ADDRESS	BIT	NAME	DESCRIPTION	DEFAULT VALUE
DAC Clear Enable 0	0x18	7	CLREN-C1	This register determines which DACs go into clear state when a clear event is detected as configured in the DAC-CLEAR-SOURCE registers. If CLREN _n = '1', DAC _n is forced into a clear state with a clear event. If CLREN _n = '0', a clear event does not affect the state of DAC _n .	0
		6	CLREN-C0		0
		5	CLREN-B7		0
		4	CLREN-B6		0
		3	CLREN-A11		0
		2	CLREN-A10		0
		1	CLREN-A9		0
		0	CLREN-A8		0

Table 23. Register name: DAC Clear Enable 1 – Address: 0x19, Default: 0x00 (READ/WRITE)

REGISTER NAME	ADDRESS	BIT	NAME	DESCRIPTION	DEFAULT VALUE
DAC Clear Enable 1	0x19	7:4	Reserved	Reserved for factory use	All zeros
		3	CLREN-D5	This register determines which DACs go into clear state when a clear event is detected as configured in the DAC-CLEAR-SOURCE registers. If CLREN _n = '1', DAC _n is forced into a clear state with a clear event. If CLREN _n = '0', a clear event does not affect the state of DAC _n .	0
		2	CLREN-D4		0
		1	CLREN-D3		0
		0	CLREN-D2		0

8.5.5 DAC Clear And ALARMOUT Source Select: Address 0x1A – 0x1D

Table 24. Register name: Register name: DAC Clear Source 0 – Address: 0x1A, Default: 0x00 (READ/WRITE)

REGISTER NAME	ADDRESS	BIT	NAME	DESCRIPTION	DEFAULT VALUE
DAC Clear Source 0	0x1A	7:5	Reserved	Reserved for factory use	000
		4	ADC16-ALR-CLR	This register selects which alarm forces DACs into a clear state, regardless of which DAC operation mode is active, auto or manual. In order for DAC _n to go into clear mode, it must be enabled in the DAC Clear Enable registers.	0
		3	ADC15-ALR-CLR		0
		2	ADC14-ALR-CLR		0
		1	ADC13-ALR-CLR		0
		0	ADC12-ALR-CLR		0

Table 25. Register name: Register name: DAC Clear Source 1 – Address: 0x1B, Default: 0x00 (READ/WRITE)

REGISTER NAME	ADDRESS	BIT	NAME	DESCRIPTION	DEFAULT VALUE
DAC Clear Source 1	0x1B	7:4	Reserved	Reserved for factory use	0000
		3	ALARMIN-ALR	This register selects which alarm forces DACs into a clear state, regardless of which DAC operation mode is active, auto or manual. In order for DAC _n to go into clear mode, it must be enabled in the DAC Clear Enable registers.	0
		2	THERM-ALR		0
		1	LT-HIGH-ALR		0
		0	LT-LOW-ALR		0

Table 26. Register name: $\overline{\text{ALARMOUT}}$ Source 0 – Address: 0x1C, Default: 0x00 (READ/WRITE)

REGISTER NAME	ADDRESS	BIT	NAME	DESCRIPTION	DEFAULT VALUE
ALARM OUT Source 0	0x1C	7:5	Reserved	Reserved for factory use	000
		4	ADC16-ALR-OUT	This register selects which alarms can activate the $\overline{\text{ALARMOUT}}$ terminal. The $\overline{\text{ALARMOUT}}$ must be enabled for this function to take effect.	0
		3	ADC15-ALR-OUT		0
		2	ADC14-ALR-OUT		0
		1	ADC13-ALR-OUT		0
		0	ADC12-ALR-OUT		0

Table 27. Register name: $\overline{\text{ALARMOUT}}$ Source 1 – Address: 0x1D, Default: 0x00 (READ/WRITE)

REGISTER NAME	ADDRESS	BIT	NAME	DESCRIPTION	DEFAULT VALUE
ALARM OUT Source 1	0x1D	7:5	Reserved	Reserved for factory use	000
		4	ALARM-LATCH-DIS	Alarm latch disable bit. When cleared to 0 the alarm bits are latched. When an alarm occurs, the corresponding alarm bit is set to "1". The alarm bit remains until the error condition subsides and the alarm register is read. Before reading, the alarm bit is not cleared even if the alarm condition disappears. When set to 1 the alarm bits are not latched. When the alarm condition subsides, the alarm bits are cleared regardless of whether the alarm bits have been read or not.	0
		3	ALRIN-ALR-OUT	This register selects which alarms can activate the $\overline{\text{ALARMOUT}}$ terminal. The $\overline{\text{ALARMOUT}}$ must be enabled for this function to take effect.	0
		2	THERM-ALR-OUT		0
		1	LT-HIGH-ALR-OUT		0
		0	LT-LOW-ALR-OUT		0

8.5.6 DAC Range: Address 0x1E

Table 28. Register name: DAC Range – Address: 0x1E, Default: 0x00 (READ/WRITE)

REGISTER NAME	ADDRESS	BIT	NAME	DESCRIPTION	DEFAULT VALUE
DAC Range	0xE1	7:4	Reserved	Reserved for factory use	0000
		3	DAC-5VRANGED	DAC _n output voltage range bit.	0
		2	DAC-5VRANGEC	VRANGEn terminal is connected to AGND:	0
		1	DAC-5VRANGEB	When the DAC-5VRANGEn bit is cleared to 0 the DAC _n group output voltage range is set to 0-10V.	0
		0	DAC-5VRANGEA	When the DACn-RANGE bit is set to 1 the DAC _n group output voltage range is set to 0-5V. VRANGEn terminal is connected to +2.5V: If the VRANGEn terminal is connected to +2.5V the DAC-5VRANGEn bit must be cleared to 0.	0

8.5.7 ADC Data: Address 0x20 – 0x41

Table 29. Register name: ADCn-Data (low byte) – Address: 0x20 - 0x41, Default: 0x00 (READ ONLY)

REGISTER NAME	ADDRESS	BIT	NAME	DESCRIPTION	DEFAULT VALUE
ADCn Data (low)	0x20 to 0x41	7:0	ADCn-DATA(7:0)	Stores the 12-bit ADC _n conversion results in straight binary format for both types of inputs channels (unipolar and bipolar)	All zeros

Table 30. Register name: ADCn-Data (high byte) – Address: 0x20 - 0x41, Default: 0x00 (READ ONLY)

REGISTER NAME	ADDRESS	BIT	NAME	DESCRIPTION	DEFAULT VALUE
ADCn Data (high)	0x20 to 0x41	7:4	Reserved	Reserved for factory use	All zeros
		3:0	ADCn-DATA (11:8)	Stores the 12-bit ADC_n conversion results in straight binary format for both types of inputs channels (unipolar and bipolar).	All zeros

8.5.8 DAC Data: Address 0x50 – 0x67

Table 31. Register name: DACn-Data (low byte) – Address: 0x50 - 0x67, Default: 0x00 (READ/WRITE)

REGISTER NAME	ADDRESS	BIT	NAME	DESCRIPTION	DEFAULT VALUE
DACn Data (low)	0x50 to 0x67	7:0	DACn-DATA(7:0)	Stores the 12-bit data to be loaded to the DAC_n latches in straight binary format. The straight binary format is used for both DAC ranges: -10 to 0V and 0 to 10V.	All zeros

Table 32. Register name: DACn-Data (high byte) – Address: 0x50 - 0x67, Default: 0x00 (READ/WRITE)

REGISTER NAME	ADDRESS	BIT	NAME	DESCRIPTION	DEFAULT VALUE
DACn Data (high)	0x50 to 0x67	7:4	Reserved	Reserved for factory use	All zeros
		3:0	DACn-DATA (11:8)	Stores the 12-bit data to be loaded to the DAC_n latches in straight binary format. The straight binary format is used for both DAC ranges: -10 to 0V and 0 to 10V.	All zeros

8.5.9 Status Registers: Address 0x70 – 0x72

The AMC7832 continuously monitors all unipolar analog inputs and local temperature sensor during normal operation. When any input is out of the specified range N consecutive times, the corresponding alarm bit is set ('1'). If the input returns to the normal range before N consecutive times, the corresponding alarm bit remains clear ('0'). This configuration avoids any false alarms. When an alarm status occurs, the corresponding alarm bit is set ('1'). When the corresponding bit in the **ALARMOUT** Source Registers is cleared ('0'), the **ALARMOUT** terminal is latched. Whenever an alarm status bit is set, it remains set until the event that caused it is resolved and its status register is read. Reading the Alarm Status Registers clears the alarm status bits. The alarm bit can only be cleared by reading its Alarm Status register after the event is resolved, or by hardware reset, software reset, or power-on reset. All alarm status bits are cleared when reading the Alarm Status registers, and all these bits are reasserted if the out-of-limit condition still exists after the next conversion cycle, unless otherwise noted.

Table 33. Register name: Alarm Status 0 – Address: 0x70, Default: 0x00 (READ ONLY)

REGISTER NAME	ADDRESS	BIT	NAME	DESCRIPTION	DEFAULT VALUE
Alarm Status 0	0x70	7:5	Reserved	Reserved for factory use	000
		4	ADC16-ALR	ADC16-ALR = '1' when ADC16 is out of the range defined by the corresponding threshold registers. ADC16-ALR = '0' when the analog input is not out of the specified range.	0
		3	ADC15-ALR	ADC15-ALR = '1' when ADC16 is out of the range defined by the corresponding threshold registers. ADC15-ALR = '0' when the analog input is not out of the specified range.	0
		2	ADC14-ALR	ADC14-ALR = '1' when ADC16 is out of the range defined by the corresponding threshold registers. ADC14-ALR = '0' when the analog input is not out of the specified range.	0
		1	ADC13-ALR	ADC13-ALR = '1' when ADC16 is out of the range defined by the corresponding threshold registers. ADC13-ALR = '0' when the analog input is not out of the specified range.	0
		0	ADC12-ALR	ADC12-ALR = '1' when ADC16 is out of the range defined by the corresponding threshold registers. ADC12-ALR = '0' when the analog input is not out of the specified range.	0

Table 34. Register name: Alarm Status 1 – Address: 0x71, Default: 0x00 (READ ONLY)

REGISTER NAME	ADDRESS	BIT	NAME	DESCRIPTION	DEFAULT VALUE
Alarm Status 1	0x71	7:4	Reserved	Reserved for factory use	0000
		3	ALARMIN-ALR	The ALARMIN-ALR is set to '1' if the $\overline{\text{ALARMIN}}$ terminal is enabled and set high.	0
		2	THERM-ALR	Thermal alarm flag. When the die temperature is equal to or greater than +150°C, the bit is set ('1') and the THERM-ALR flag activates. The on-chip temperature sensor (LT) monitors the die temperature. If LT is disabled, the THERM-ALR bit is always '0'. The hysteresis of this alarm is 8°C.	0
		1	LT-HIGH-ALR	LT-LOW-ALR = '1' when the temperature sensor is out of the range defined by the upper threshold.	0
		0	LT-LOW-ALR	LT-LOW-ALR = '1' when the temperature sensor is out of the range defined by the lower threshold.	0

Table 35. Register name: General Status – Address: 0x72, Default: 0x00 (READ ONLY)

REGISTER NAME	ADDRESS	BIT	NAME	DESCRIPTION	DEFAULT VALUE
General Status	0x72	7:3	Reserved	Reserved for factory use	All zeros
		2	Reserved	Reserved for factory use	0
		1	GALR	Global alarm bit. This bit is the OR function of all individual alarm bits of the status register.	0
		0	$\overline{\text{DAVF}}$	ADC Data available flag bit. Direct mode only. Always cleared in Auto mode. 0: ADC conversion is in progress or ADC is in Auto mode 1: ADC conversions are complete and new data is available	0

8.5.10 Temperature And GPIO Data: Address 0x78 – 0x7A

Table 36. Register name: Temperature Data (low byte) – Address: 0x78, Default: 0x00 (READ ONLY)

REGISTER NAME	ADDRESS	BIT	NAME	DESCRIPTION	DEFAULT VALUE
Temp Data (low)	0x78	7:0	TEMP-DATA(7:0)	Stores the temperature sensor reading in twos complement format.	0x00

Table 37. Register name: Temperature Data (high byte) – Address: 0x79, Default: 0x00 (READ ONLY)

REGISTER NAME	ADDRESS	BIT	NAME	DESCRIPTION	DEFAULT VALUE
Temp Data (high)	0x79	7:4	Reserved	Reserved for factory use.	All zeros
		3:0	TEMP-DATA(11:8)	Stores the temperature sensor reading in twos complement format.	0x00

Table 38. Register name: GPIO – Address: 0x7A, Default: 0xFF (READ/WRITE)

REGISTER NAME	ADDRESS	BIT	NAME	DESCRIPTION	DEFAULT VALUE
GPIO	0x7A	7	GPIO-7	For write operation the GPIO terminal operates as an output. Writing a '1' to the GPIO-n bit sets the GPIO-N terminal to high impedance. Writing a '0' sets the GPIO-n terminal to logic low. For read operations the GPIO terminal operates as an input. Read the GPIO-n bit to receive the status of the GPIO-n terminal. After power-on reset, or any forced hardware or software reset, the GPIO-n terminal has a 48-kΩ input impedance to IOV _{DD} .	1
		6	GPIO-6		1
		5	GPIO-5		1
		4	GPIO-4		1
		3	GPIO-3		1
		2	GPIO-2		1
		1	GPIO-1		1
		0	GPIO-0		1

8.5.11 Out-Of-Range ADC Thresholds: Address 0x80 – 0x93

The unipolar analog inputs (LV_ADC12 to LV_ADC16) and the local temperature sensor implement an out-of-range alarm function. The Upper-Thresh and Lower-Thresh registers define the upper bound and lower bounds for these inputs. This window determines whether the analog input or temperature is out-of-range. When the input is outside the window, the corresponding CH-ALR-n bit in the Status Register is set to '1'. For normal operation, the value of the upper threshold must be greater than the value of lower threshold; otherwise, an alarm is always indicated. The analog input threshold values are specified in straight binary format while the local temperature ones are specified in two's complement format.

Table 39. Register name: ADCn-Upper-Thresh (low byte) – Address: 0x80 - 0x93, Default: 0xFF (READ/WRITE)

REGISTER NAME	ADDRESS	BIT	NAME	DESCRIPTION	DEFAULT VALUE
ADCn Upper Thresh (low)	0x80 to 0x93	7:0	THRU _n (7:0)	Sets 12-bit upper threshold value for the ADC _n channel in straight binary format.	0xFF

Table 40. Register name: ADCn-Upper-Thresh (high byte) – Address: 0x80 - 0x93, Default: 0x0F (READ/WRITE)

REGISTER NAME	ADDRESS	BIT	NAME	DESCRIPTION	DEFAULT VALUE
ADCn Upper Thresh (high)	0x80 to 0x93	7:4	Reserved	Reserved for factory use.	All zeros
		3:0	THRU _n (11:8)	Sets 12-bit upper threshold value for ADC _n channel in straight binary format.	0x0F

Table 41. Register name: ADCn-Lower-Thresh (low byte) – Address: 0x80 - 0x93, Default: 0x00 (READ/WRITE)

REGISTER NAME	ADDRESS	BIT	NAME	DESCRIPTION	DEFAULT VALUE
ADCn Lower Thresh (low)	0x80 to 0x93	7:0	THRL _n (7:0)	Sets 12-bit lower threshold value for the ADC _n channel in straight binary format.	0x00

Table 42. Register name: ADCn-Lower-Thresh (high byte) – Address: 0x80 - 0x93, Default: 0x00 (READ/WRITE)

REGISTER NAME	ADDRESS	BIT	NAME	DESCRIPTION	DEFAULT VALUE
ADCn Lower Thresh (high)	0x80 to 0x93	7:4	Reserved	Reserved for factory use.	All zeros
		3:0	THRL _n (11:8)	Sets 12-bit lower threshold value for ADC _n channel in straight binary format.	0x00

Table 43. Register name: LT-Upper-Thresh (low byte) – Address: 0x94, Default: 0xFF (READ/WRITE)

REGISTER NAME	ADDRESS	BIT	NAME	DESCRIPTION	DEFAULT VALUE
LT Upper Thresh (low)	0x94	7:0	THRU-LT(7:0)	Sets 12-bit upper threshold value for the local temperature sensor in two's complement format.	0xFF

Table 44. Register name: LT-Upper-Thresh (high byte) – Address: 0x95, Default: 0x07 (READ/WRITE)

REGISTER NAME	ADDRESS	BIT	NAME	DESCRIPTION	DEFAULT VALUE
LT Upper Thresh (high)	0x95	7:4	Reserved	Reserved for factory use.	All zeros
		3:0	THRU-LT(11:8)	Sets 12-bit upper threshold value for the local temperature sensor in two's complement format.	0x07

Table 45. Register name: LT-Lower-Thresh (low byte) – Address: 0x96, Default: 0x00 (READ/WRITE)

REGISTER NAME	ADDRESS	BIT	NAME	DESCRIPTION	DEFAULT VALUE
LT Lower Thresh (low)	0x96	7:0	THRL-LT(7:0)	Sets 12-bit lower threshold value for the local temperature sensor in two's complement format.	0x00

Table 46. Register name: LT-Lower-Thresh (high byte) – Address: 0x97, Default: 0x08 (READ/WRITE)

REGISTER NAME	ADDRESS	BIT	NAME	DESCRIPTION	DEFAULT VALUE
LT Lower Thresh (high)	0x97	7:4	Reserved	Reserved for factory use.	All zeros
		3:0	THRL-LT(11:8)	Sets 12-bit lower threshold value for the local temperature sensor in two's complement format.	0x08

8.5.12 Hysteresis: Address 0xA0 – 0xA5

The hysteresis registers define the hysteresis in the out-of-range alarms.

Table 47. Register name: ADCn-Hysteresis – Address: 0xA0 - 0xA4, Default: 0x08 (READ/WRITE)

REGISTER NAME	ADDRESS	BIT	NAME	DESCRIPTION	DEFAULT VALUE
ADCn Hysteresis	0xA0 to 0xA4	7	Reserved	Reserved for factory use.	0
		6:0	HYSTn(6:0)	Hysteresis of unipolar LV_ADCn, 1 LSB per step	0x08

Table 48. Register name: LT-Hysteresis – Address: 0xA5, Default: 0x08 (READ/WRITE)

REGISTER NAME	ADDRESS	BIT	NAME	DESCRIPTION	DEFAULT VALUE
LT Hysteresis	0xA5	7:5	Reserved	Reserved for factory use.	000
		4:0	HYST-LT(4:0)	Hysteresis of local temperature sensor, 1°C per step. The range is 0°C to 31°C.	All zeros

8.5.13 Power-Down Registers: Address 0xB0 – 0xB3

Table 49. Register name: DAC Clear 0 – Address: 0xB0, Default: 0x00 (READ/WRITE)

REGISTER NAME	ADDRESS	BIT	NAME	DESCRIPTION	DEFAULT VALUE
DAC Clear 0	0xB0	7	CLR-C1	This register uses software to force the DAC into a clear state. If CLRn = '1', DAC_n is forced into a clear state. If CLRn = '0', DAC_n is restored to normal operation.	0
		6	CLR-C0		0
		5	CLR-B7		0
		4	CLR-B6		0
		3	CLR-A11		0
		2	CLR-A10		0
		1	CLR-A9		0
		0	CLR-A8		0

Table 50. Register name: DAC Clear 1 – Address: 0xB1, Default: 0x00 (READ/WRITE)

REGISTER NAME	ADDRESS	BIT	NAME	DESCRIPTION	DEFAULT VALUE
DAC Clear 1	0xB1	7:4	Reserved	Reserved for factory use	All zeros
		3	CLR-D5	This register uses software to force the DAC into a clear state. If CLRn = '1', DAC_n is forced into a clear state. If CLRn = '0', DAC_n is restored to normal operation.	0
		2	CLR-D4		0
		1	CLR-D3		0
		0	CLR-D2		0

Table 51. Register name: Register name: Power-down 0 – Address: 0xB2, Default: 0x00 (READ/WRITE)

REGISTER NAME	ADDRESS	BIT	NAME	DESCRIPTION	DEFAULT VALUE
Power Down 0	0xB2	7	PDAC-C1	After power-on or reset, all bits in the Power-Down Register are cleared to '0', and all the components controlled by this register are either powered-down or off. The Power-Down Register allows the host to manage the AMC7832 power dissipation. When not required, the ADC, internal reference, reference buffer amplifiers, and any of the DACs can be put into an inactive low-power mode to reduce current drain from the supply. The bits in the Power-Down Register control this power-down function. Set the respective bit to '1' to activate the corresponding function.	0
		6	PDAC-C0		0
		5	PDAC-B7		0
		4	PDAC-B6		0
		3	PDAC-A11		0
		2	PDAC-A10		0
		1	PDAC-A9		0
		0	PDAC-A8		0

Table 52. Register name: Register name: Power-down 1 – Address: 0xB3, Default: 0x00 (READ/WRITE)

REGISTER NAME	ADDRESS	BIT	NAME	DESCRIPTION	DEFAULT VALUE
Power Down 1	0xB3	7	PREF_OUT1	After power-on or reset, all bits in the Power-Down Register are cleared to '0', and all the components controlled by this register are either powered-down or off. The Power-Down Register allows the host to manage the AMC7832 power dissipation. When not required, the ADC, internal reference, reference buffer amplifiers, and any of the DACs can be put into an inactive low-power mode to reduce current drain from the supply. The bits in the Power-Down Register control this power-down function. Set the respective bit to '1' to activate the corresponding function.	0
		6	PREF_OUT2		0
		5	PREF		0
		4	PADC		0
		3	PDAC-D5		0
		2	PDAC-D4		0
		1	PDAC-D3		0
		0	PDAC-D2		0

8.5.14 ADC Trigger: Address 0xC0

Table 53. Register name: ADC Trigger – Address: 0xC0, Default: 0x00 (WRITE ONLY)

REGISTER NAME	ADDRESS	BIT	NAME	DESCRIPTION	DEFAULT VALUE
ADC Trigger	0xC0	7:1	Reserved	Reserved for factory use	All zeros
		0	ICONV	Internal ADC conversion bit. Set this bit to '1' to start the ADC conversion internally. The bit is automatically cleared to '0'.	0

9 Applications and Implementation

9.1 Application Information

The AMC7832 device is a highly integrated, low-power, complete analog monitoring and control solution. Although the device can be used in many different systems -- Industrial Control, Test and Measurement, and Optical Communications -- the device is largely used in multi-channel RF communication driven applications which incorporate power amplifiers.

Power amplifiers (PAs) include transistor technologies that are extremely temperature sensitive, and require DC biasing circuits to optimize RF performance, power efficiency, and stability. The AMC7832 device provides 12 DAC channels, which can be used to bias the inputs of the power amplifiers. The device also includes an internal local temperature sensor, and 17 ADC channels for general-purpose monitoring.

There are mainly two different types of monitoring schemes: current sensing, and temperature sensing. In the current-sense application the PA drain current is monitored by measuring the shunt resistor's differential voltage drop. The device's internal local temperature sensor and analog inputs – which can be configured for remote temperature ICs or thermistors – can be used to detect temperature variations during PA operation. [Figure 57](#) shows the block diagrams to these different systems.

9.2 Typical Application

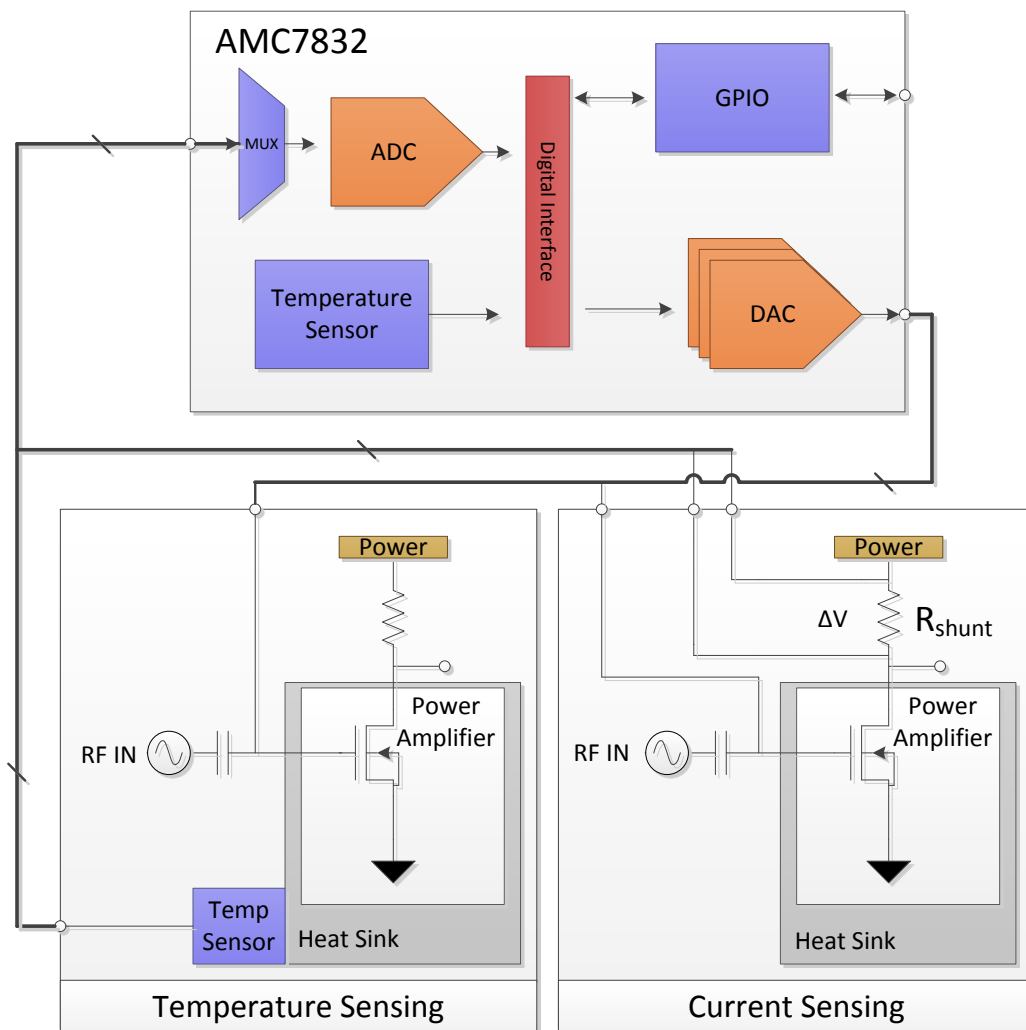

Figure 57. AMC7832 Example Control and Monitor System

Typical Application (continued)

9.2.1 Application Schematic

An example schematic incorporating the AMC7832 is listed in Figure 58.

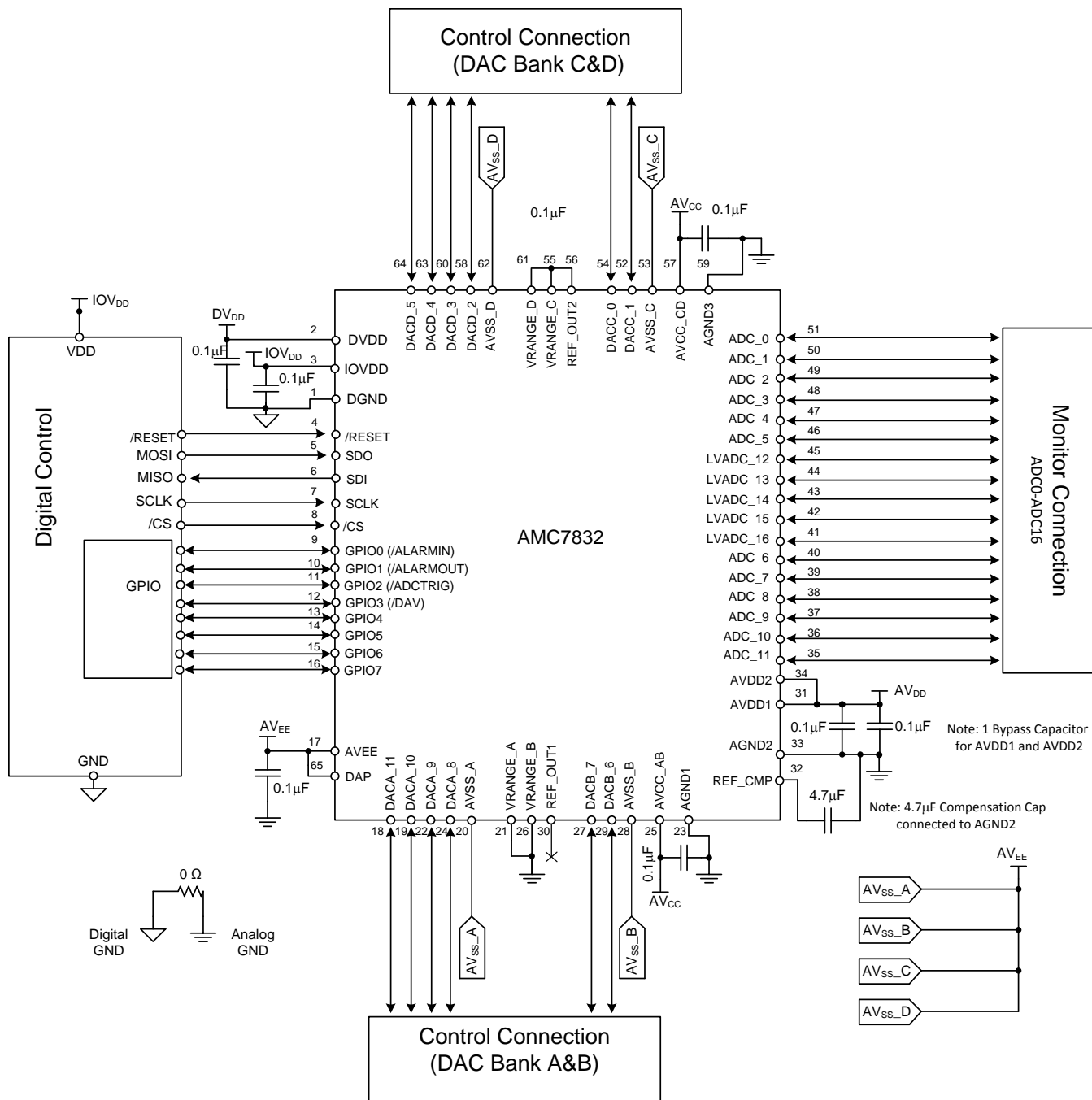

Figure 58. AMC7832 Example Schematic

Typical Application (continued)

9.2.2 Design Requirements

The AMC7832 Example Schematic uses most of the following design parameters.

Table 54. Design Parameters

DESIGN PARAMETER	EXAMPLE VALUE	
AV _{CC} AV _{EE} IOV _{DD} DV _{DD} AV _{DD}	5V -12V 3.3V 5V 5V	
ADC Bipolar inputs ADC Unipolar inputs	(ADC0 – ADC11) (LV_ADC12 – LV_ADC16)	-12.5 to +12.5-V input range 0 to +5-V range
DAC Output voltage Ranges	VRANGE _A : GND VRANGE _B : GND VRANGE _C : 2.5V (REF_OUT2) VRANGE _D : 2.5V (REF_OUT2)	[0 to +5-V Range] [0 to +5-V Range] [-10 to 0-V Range] [-10 to 0-V Range]
Remote temperature sensing	IC Temperature sensor (LM50) or thermistor	

9.2.3 Detailed Design Procedure

The following displays a set of parameters and concepts that will facilitate the design process:

- AV_{CC} and AV_{EE} voltage values
- ADC input voltage range
- DAC Output voltage Ranges
- Remote temperature applications

9.2.3.1 ADC Input Conditioning

The AMC7832 has a single ADC core that features a multi-channel multiplexer input stage to a successive approximation register (SAR) ADC. The analog inputs are separated into two input classes: bipolar ADC inputs (high-voltage) and unipolar ADC Inputs (low-voltage). The high-voltage analog inputs (ADC_0 – ADC_11) feature a -12.5-V to +12.5-V input range, while the low-voltage analog inputs (LV_ADC12 – LV_ADC16) accept a full-scale range of 0 to 2 x V_{REF} (V_{REF} corresponds to a +2.5-V internal reference to the ADC block, and is externally available on the REF_CMP pin). For additional noise filtering, a 4.7-μF capacitor is recommended between the REF_CMP and GND. The value of this cap must exceed 470nF to ensure reference stability. A high-quality ceramic type NP0 or X7R is recommended for its optimal performance across temperature, and very low dissipation factor.

During conversion the input current per channel will vary with the total update time which is determined by the number and type of channels (NCH) and the conversion rate setting CONV-RATE in the ADC Configuration register (address 0x10). This information is displayed in [Table 55](#).

$$I_{IN} = F_S \times \Delta V \times C_{IN} \tag{5}$$

Where:

C_{IN}: Internal ADC input channel capacitance

ΔV : The maximum voltage difference between analog inputs

F_S = f(CONV_{RATE}, NCH_{BIPOLAR}, NCH_{UNIPOLAR}) = 1/T_S

The total update time (T_S) can be determined from [Table 55](#).

Table 55. ADC Update Time per Input Channel

CONV-RATE[1:0]	T _S (μs) / CHANNEL UNIPOLAR INPUT CHANNEL	T _S (μs) / CHANNEL BIPOLAR INPUT CHANNEL	T _S (μs) TEMPERATURE SENSOR CHANNEL
00	11.5	34.5	256
01	23	34.5	256
10	34.5	34.5	256
11	69	69	256

To reduce DC error in sampling, it is recommended to decrease the ADC input impedance and reduce any input capacitance to ground. Increasing the input capacitance essentially increases C_{IN} , and therefore increases the required amount of input current (I_{IN}).

In applications where the signal source has high impedance, it is recommended that the analog input is buffered before applying to the ADC channel.

Special care must be taken when biasing the two input classes, as both classes have different voltages – with respect to GND – that they cannot exceed. These voltage values are located in [Absolute Maximum Ratings](#).

9.2.3.2 DAC Output Range Selection

The AMC7832 contains 12 DACs that are arranged by different DAC banks, where each channel within a bank shares a common programmable voltage range. Each DAC bank is fully programmable with up to three different voltage ranges: -10 to 0-V, 0 to +10-V, and 0 to +5-V. The VRANGE terminals combined with the DAC configuration register sets the different DAC voltage ranges.

The output buffer is capable of generating rail-to rail voltages on its output, giving an output range of AVSS to AV_{CC}. The maximum source and sink capability of this internal amplifier is listed in the [Electrical Characteristics DAC Output Characteristics](#).

The graphs listed in the Application plots section illustrate the relationship of both stability and settling time with different capacitive and resistive loading structures.

9.2.3.3 Temperature Sensing Applications

The AMC7832 contains one local temperature and 5 low-voltage unipolar channels that are easily configurable to remote temperature sensor circuits. The integrated temperature sensor and analog input registers automatically update with every conversion. An example of a remote temperature sensor connection is displayed in [Figure 59](#).

The temperature sensor described is a LM50, a high precision integrated-circuit temperature sensor that can sense a -40°C to +125°C temperature range using a single positive supply. The full-scale output of the temperature sensor ranges from +100mV to +1.75V for a -40°C to +125°C temperature range. In an extremely noisy environment it may be necessary to add some filtering to minimize noise pickup. A typical recommended value for the bypass capacitor is 0.1µF from V+ to GND. A high-quality ceramic type NPO or X7R is recommended for its optimal performance across temperature, and very low dissipation factor.

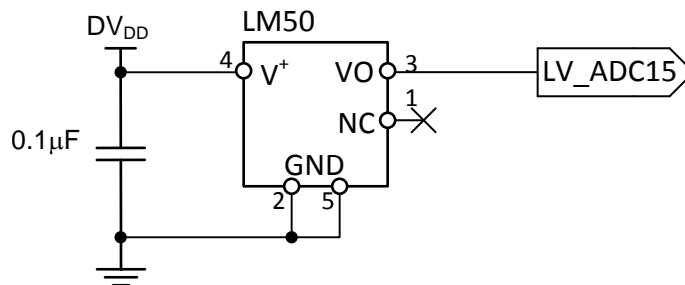
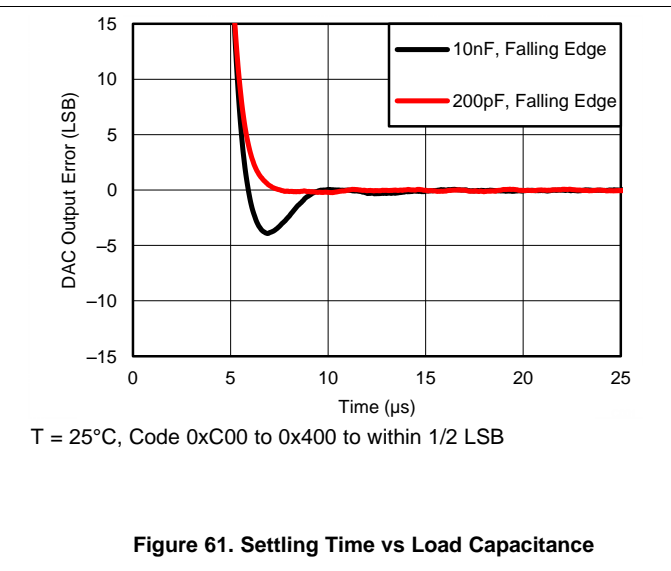
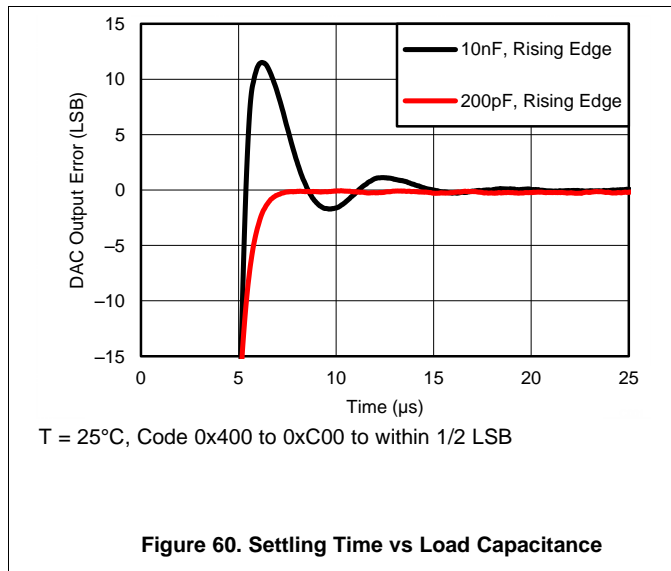

Figure 59. External Remote Temperature IC (LM50) Connected to AMC7832 (LV_ADC15) Input Pin

9.2.3.4 Application Curves



10 Power Supply Recommendations

The preferred (not required) order for applying power is IOV_{DD}, DV_{DD}/AV_{DD} and then AV_{CC}/AV_{EE}. When power sequencing, ensure that all digital terminals are not powered, or in an active state while IOV_{DD} ramps. This can be accomplished by attaching 10-kΩ pull-up resistors to IOV_{DD}, or pull-down resistors to DGND.

The supply voltage ranges are specified in the [Recommended Operating Conditions](#) but are repeated here for convenience.

PARAMETER	TEST CONDITIONS	MIN	TYP	MAX	UNIT
SUPPLY VOLTAGE RANGE					
AV _{DD}		4.5	5	5.5	V
DV _{DD}	DV _{DD} must be equal to AV _{DD}	4.5	5	5.5	V
IOV _{DD}	IOV _{DD} must be equal or less than DV _{DD}	1.8		5.5	V
AV _{CC}		4.5	12	12.5	V
AV _{EE}		-12.5	-12	0	V
AVSS _{A,B,C,D}		AV _{EE}		0	V
OPERATING RANGE					
Specified temperature range		-40	25	105	°C

All registers initialize to the default values after these supplies have been established. Communication with the AMC7832 will be valid after a 250-μS maximum power-on reset delay. The default state of all analog blocks is off as determined by the power-down registers (0xB2 and 0xB3). Before writing to this register, a hardware reset should be issued to ensure specified operation of the AMC7832. Communication to the AMC7832 will be valid after a maximum 250-μS reset delay from the rising edge of $\overline{\text{RESET}}$.

If DV_{DD} falls below +4.5-V, the minimum supply value of DV_{DD}, either a hardware or power-on reset should be issued before proper operation can be resumed.

When powered on, the internal POR circuit invokes a power-on reset, which performs the equivalent function of the $\overline{\text{RESET}}$ terminal. To ensure a POR, DV_{DD} must start from a level below 750-mV.

11 Layout

11.1 Layout Guidelines

- All Power Supply terminals should be bypassed to ground with a low ESR ceramic bypass capacitor. The typical recommended bypass capacitance is 10- μ F ceramic with a X7R or NP0 dielectric.
- To minimize interaction between the analog and digital return currents, the digital and analog sections should have separate ground planes that eventually connect at some point.
- To reduce noise on the internal reference, a 4.7- μ F capacitor is recommended between the REF_CMP and GND.
- A high-quality ceramic type NP0 or X7R is recommended for its optimal performance across temperature, and very low dissipation factor.

11.2 Layout Example

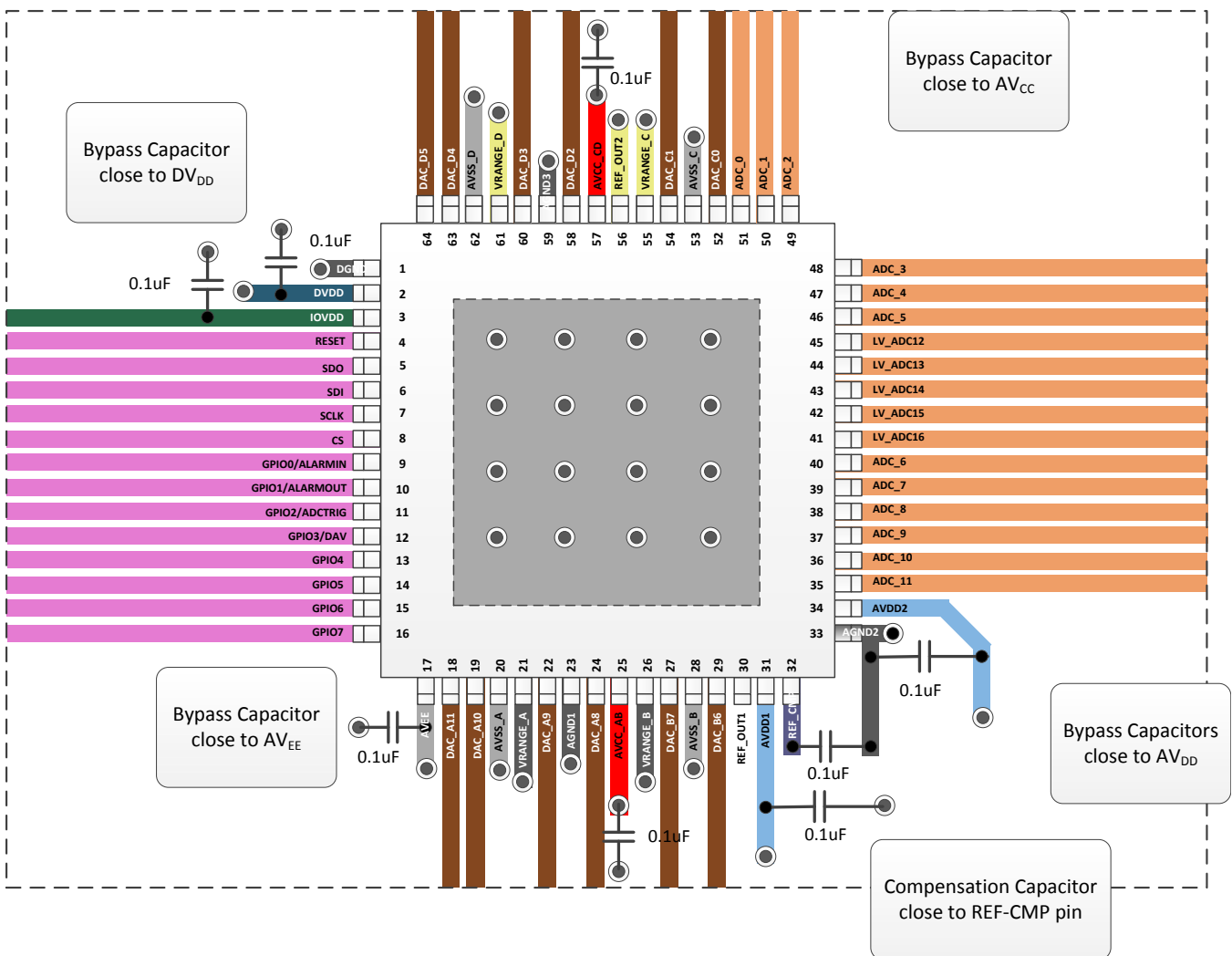

Figure 62. AMC7832 Example Board Layout

Layout Example (continued)

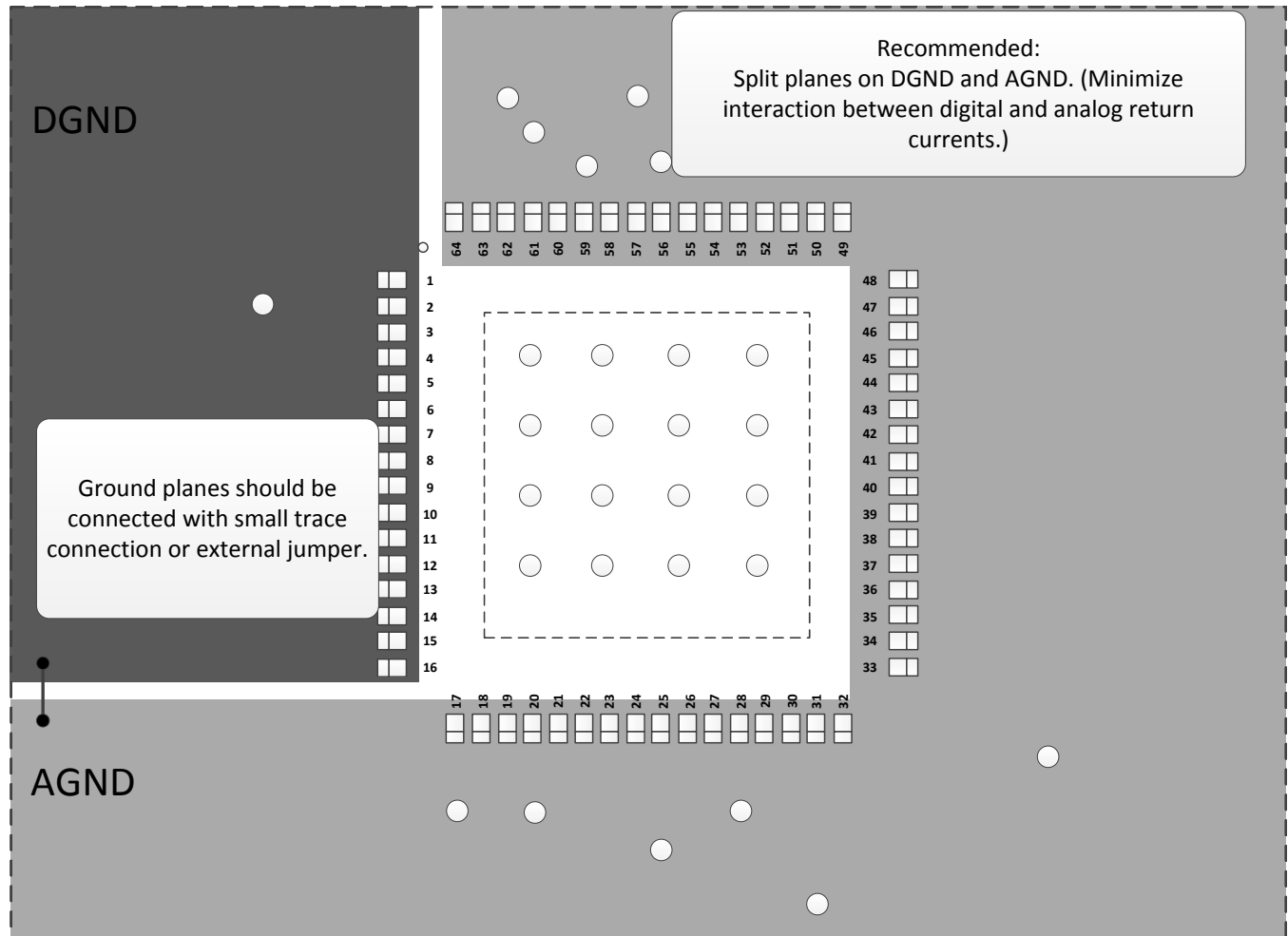

Figure 63. AMC7832 Example Board Layout – Ground Planes

Layout Example (continued)

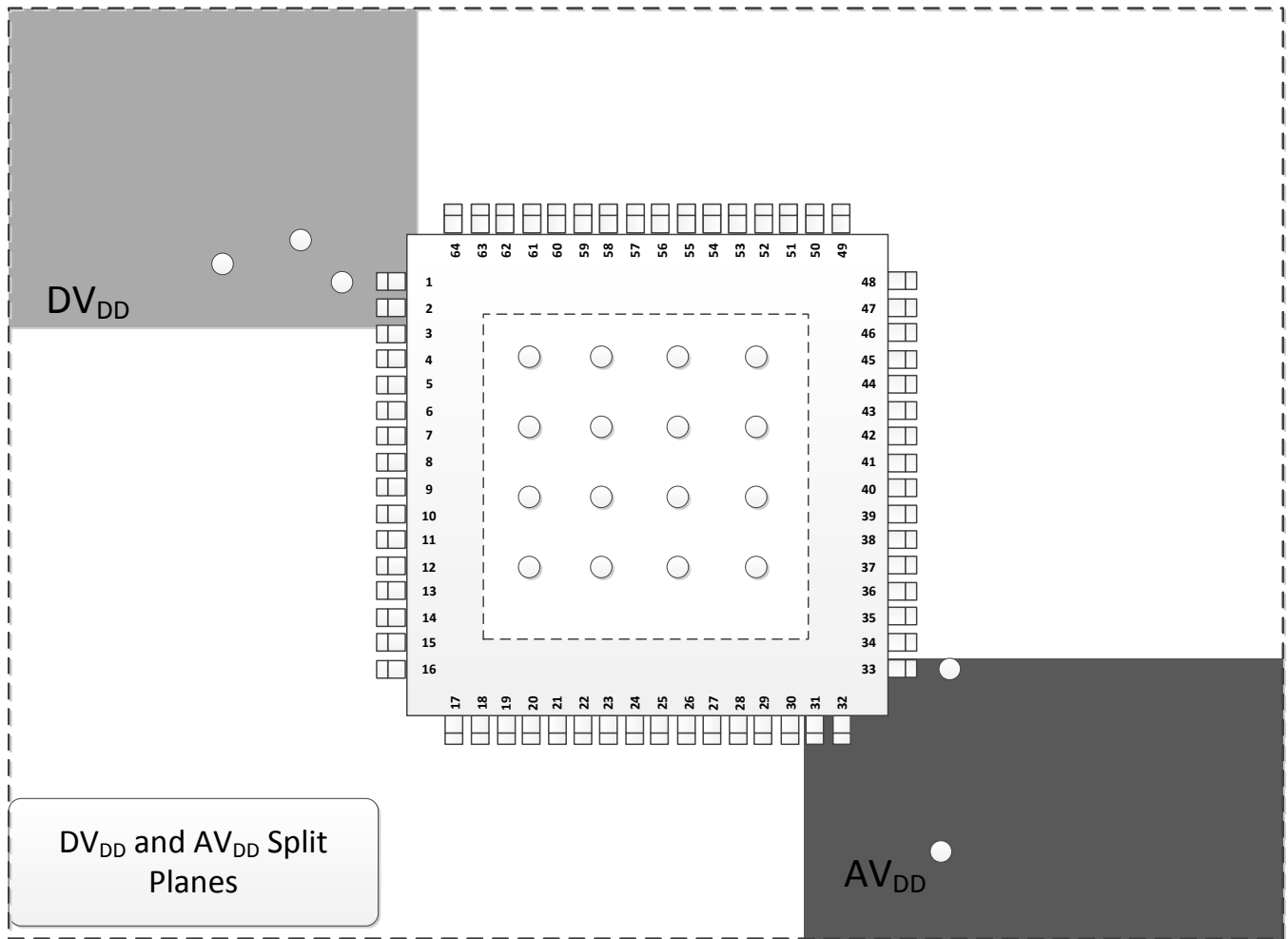

Figure 64. AMC7832 Example Board Layout – Power Planes

Layout Example (continued)

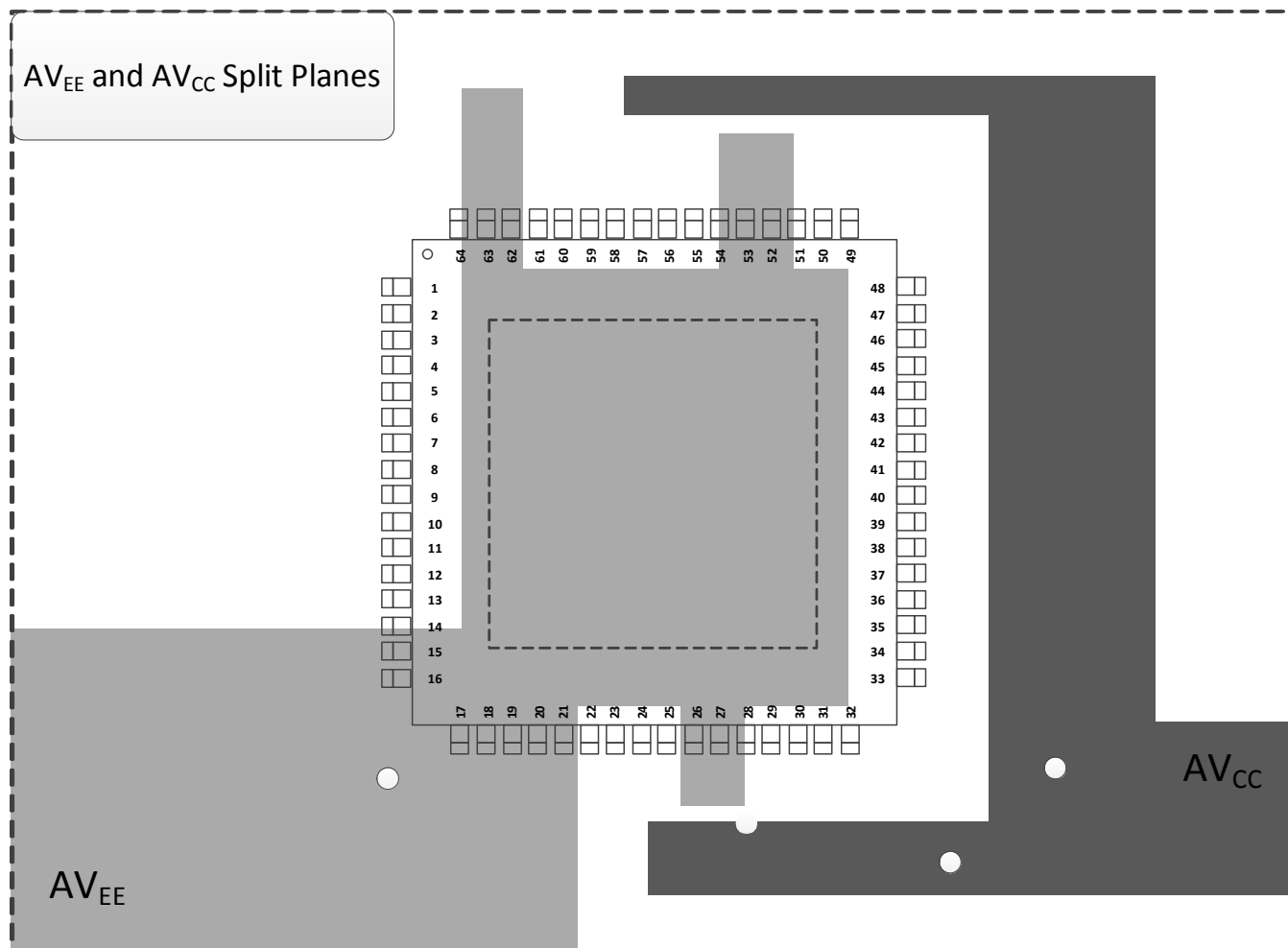

Figure 65. AMC7832 Example Board Layout – Analog Power Planes

12 Device and Documentation Support

12.1 Trademarks

All trademarks are the property of their respective owners.

12.2 Electrostatic Discharge Caution



These devices have limited built-in ESD protection. The leads should be shorted together or the device placed in conductive foam during storage or handling to prevent electrostatic damage to the MOS gates.

12.3 Glossary

[SLYZ022](#) — *TI Glossary*.

This glossary lists and explains terms, acronyms and definitions.

13 Mechanical, Packaging, and Orderable Information

The following pages include mechanical packaging and orderable information. This information is the most current data available for the designated devices. This data is subject to change without notice and revision of this document. For browser-based versions of this data sheet, refer to the left-hand navigation.

PACKAGING INFORMATION

Orderable Device	Status (1)	Package Type	Package Drawing	Pins	Package Qty	Eco Plan (2)	Lead finish/ Ball material (6)	MSL Peak Temp (3)	Op Temp (°C)	Device Marking (4/5)	Samples
AMC7832IPAP	ACTIVE	HTQFP	PAP	64	160	RoHS & Green	NIPDAU	Level-3-260C-168 HR	-40 to 125	AMC7832	Samples
AMC7832IPAPR	ACTIVE	HTQFP	PAP	64	1000	RoHS & Green	NIPDAU	Level-3-260C-168 HR	-40 to 125	AMC7832	Samples

(1) The marketing status values are defined as follows:

ACTIVE: Product device recommended for new designs.

LIFEBUY: TI has announced that the device will be discontinued, and a lifetime-buy period is in effect.

NRND: Not recommended for new designs. Device is in production to support existing customers, but TI does not recommend using this part in a new design.

PREVIEW: Device has been announced but is not in production. Samples may or may not be available.

OBSOLETE: TI has discontinued the production of the device.

(2) **RoHS:** TI defines "RoHS" to mean semiconductor products that are compliant with the current EU RoHS requirements for all 10 RoHS substances, including the requirement that RoHS substance do not exceed 0.1% by weight in homogeneous materials. Where designed to be soldered at high temperatures, "RoHS" products are suitable for use in specified lead-free processes. TI may reference these types of products as "Pb-Free".

RoHS Exempt: TI defines "RoHS Exempt" to mean products that contain lead but are compliant with EU RoHS pursuant to a specific EU RoHS exemption.

Green: TI defines "Green" to mean the content of Chlorine (Cl) and Bromine (Br) based flame retardants meet JS709B low halogen requirements of <=1000ppm threshold. Antimony trioxide based flame retardants must also meet the <=1000ppm threshold requirement.

(3) MSL, Peak Temp. - The Moisture Sensitivity Level rating according to the JEDEC industry standard classifications, and peak solder temperature.

(4) There may be additional marking, which relates to the logo, the lot trace code information, or the environmental category on the device.

(5) Multiple Device Markings will be inside parentheses. Only one Device Marking contained in parentheses and separated by a "~" will appear on a device. If a line is indented then it is a continuation of the previous line and the two combined represent the entire Device Marking for that device.

(6) Lead finish/Ball material - Orderable Devices may have multiple material finish options. Finish options are separated by a vertical ruled line. Lead finish/Ball material values may wrap to two lines if the finish value exceeds the maximum column width.

Important Information and Disclaimer:The information provided on this page represents TI's knowledge and belief as of the date that it is provided. TI bases its knowledge and belief on information provided by third parties, and makes no representation or warranty as to the accuracy of such information. Efforts are underway to better integrate information from third parties. TI has taken and continues to take reasonable steps to provide representative and accurate information but may not have conducted destructive testing or chemical analysis on incoming materials and chemicals. TI and TI suppliers consider certain information to be proprietary, and thus CAS numbers and other limited information may not be available for release.

In no event shall TI's liability arising out of such information exceed the total purchase price of the TI part(s) at issue in this document sold by TI to Customer on an annual basis.

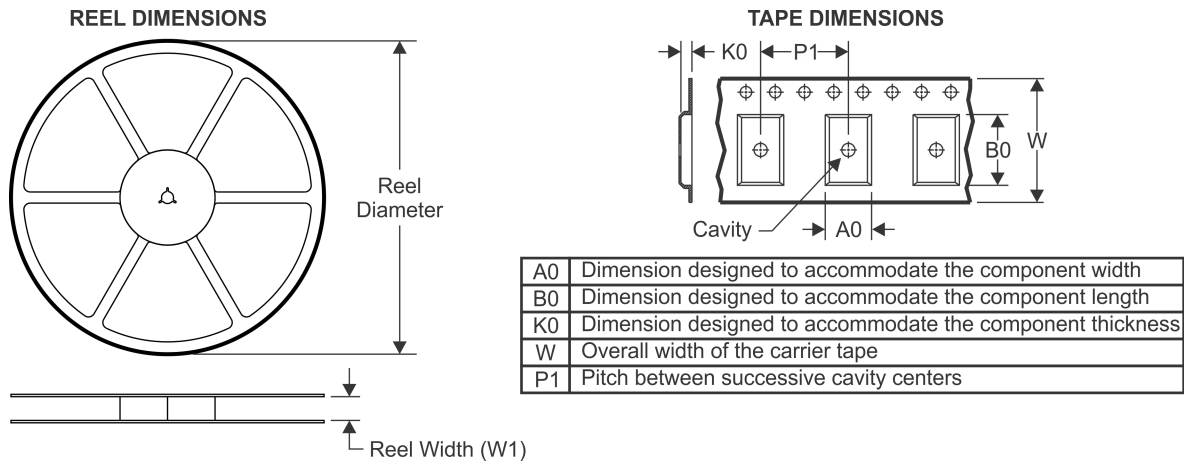
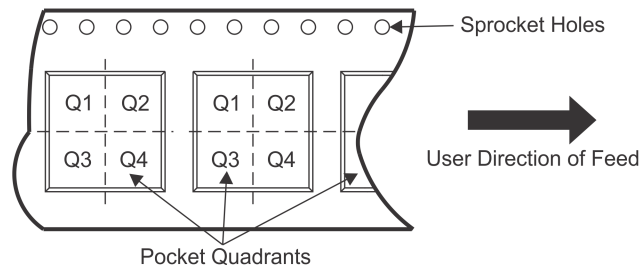
TAPE AND REEL INFORMATION

QUADRANT ASSIGNMENTS FOR PIN 1 ORIENTATION IN TAPE

*All dimensions are nominal

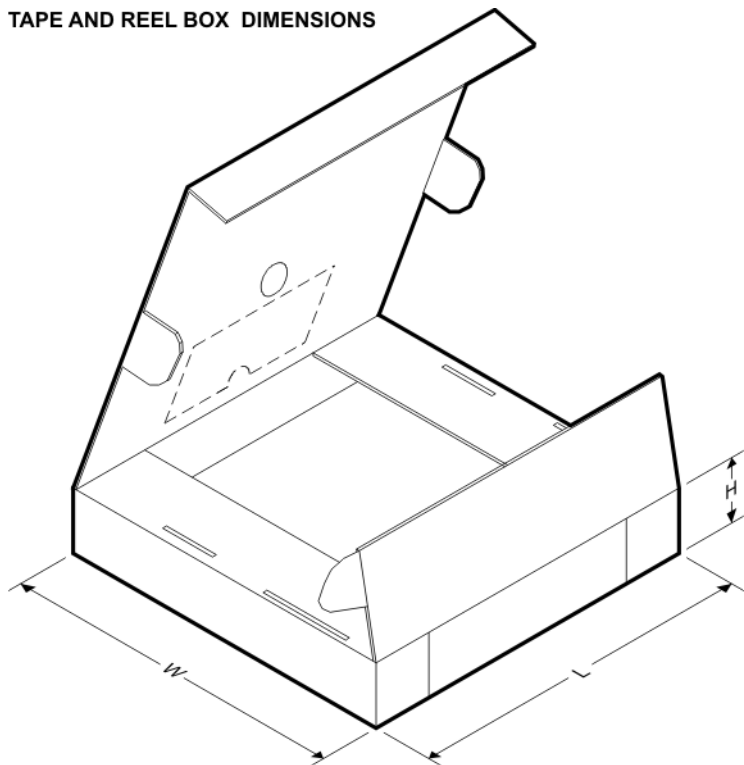
Device	Package Type	Package Drawing	Pins	SPQ	Reel Diameter (mm)	Reel Width W1 (mm)	A0 (mm)	B0 (mm)	K0 (mm)	P1 (mm)	W (mm)	Pin1 Quadrant
AMC7832IPAPR	HTQFP	PAP	64	1000	330.0	24.4	13.0	13.0	1.5	16.0	24.0	Q2

TAPE AND REEL BOX DIMENSIONS

*All dimensions are nominal

Device	Package Type	Package Drawing	Pins	SPQ	Length (mm)	Width (mm)	Height (mm)
AMC7832IPAPR	HTQFP	PAP	64	1000	367.0	367.0	55.0

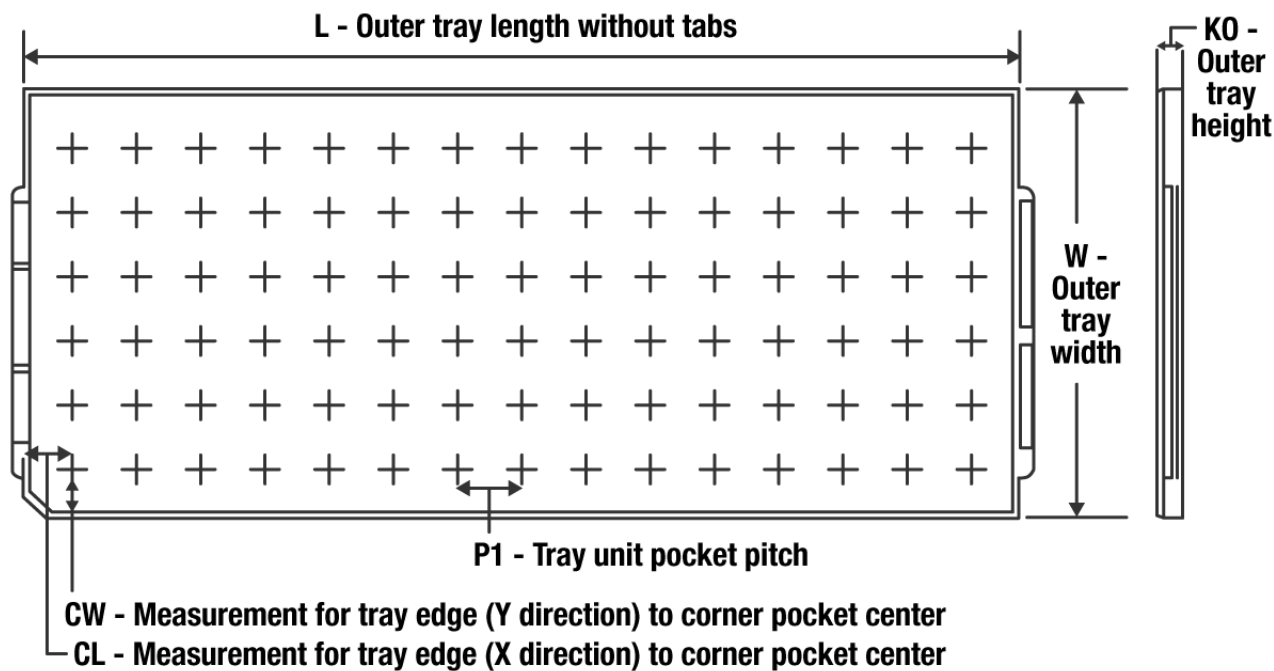
TRAY

Chamfer on Tray corner indicates Pin 1 orientation of packed units.

*All dimensions are nominal

Device	Package Name	Package Type	Pins	SPQ	Unit array matrix	Max temperature (°C)	L (mm)	W (mm)	K0 (µm)	P1 (mm)	CL (mm)	CW (mm)
AMC7832IPAP	PAP	HTQFP	64	160	8 X 20	150	322.6	135.9	7620	15.2	13.1	13

GENERIC PACKAGE VIEW

PAP 64

HTQFP - 1.2 mm max height

10 x 10, 0.5 mm pitch

QUAD FLATPACK

This image is a representation of the package family, actual package may vary.
Refer to the product data sheet for package details.

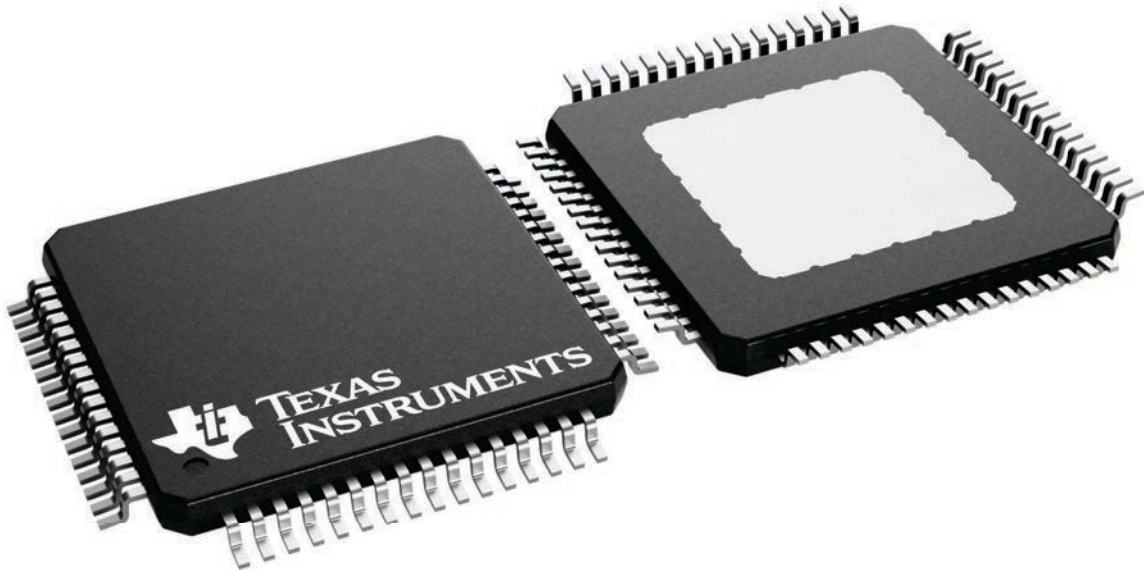

4226442/A

PAP0064G

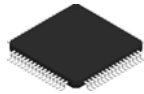

PACKAGE OUTLINE

PowerPAD™ TQFP - 1.2 mm max height

PLASTIC QUAD FLATPACK

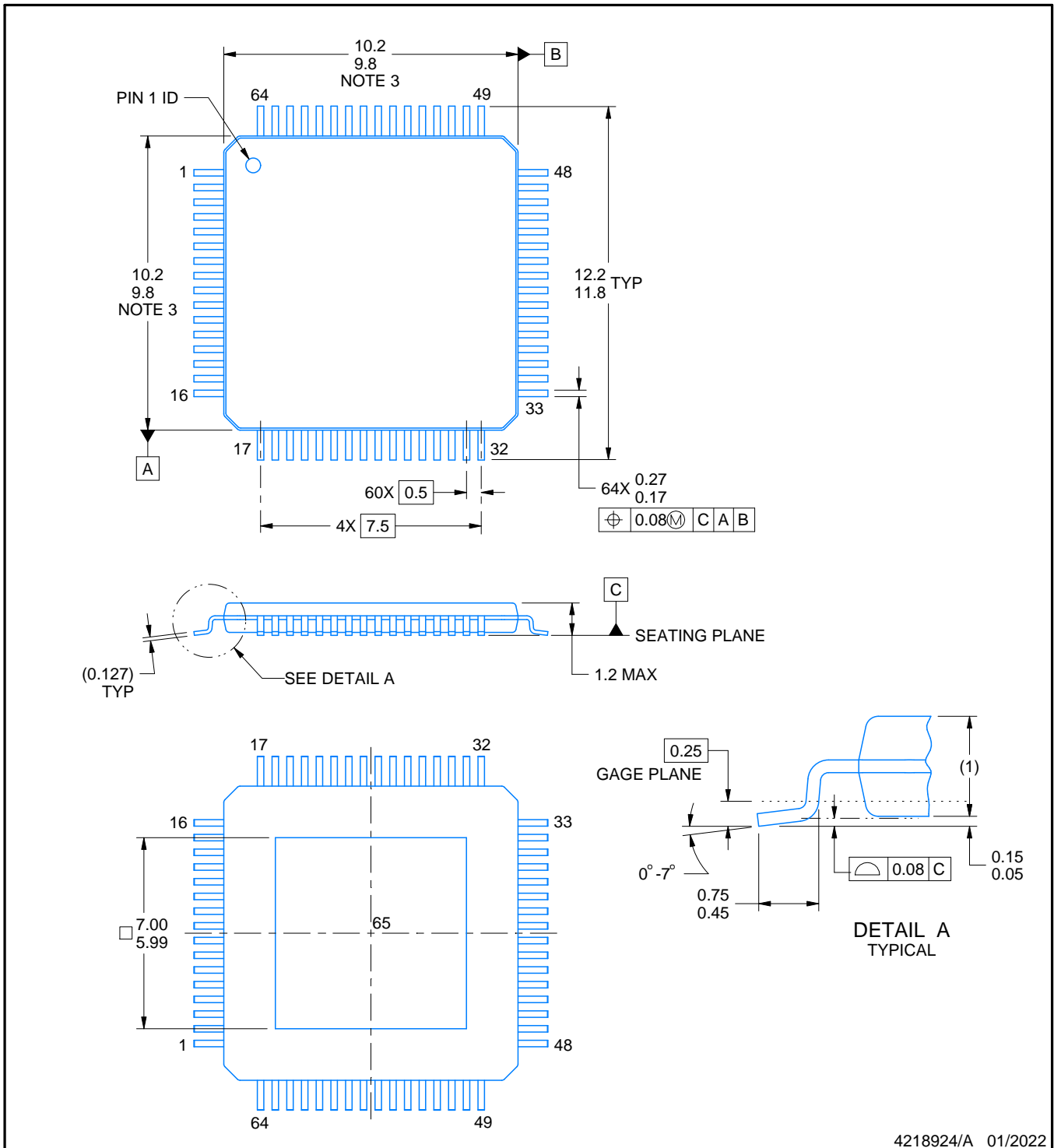

4218924/A 01/2022

NOTES:

PowerPAD is a trademark of Texas Instruments.

1. All linear dimensions are in millimeters. Any dimensions in parenthesis are for reference only. Dimensioning and tolerancing per ASME Y14.5M.
2. This drawing is subject to change without notice.
3. This dimension does not include mold flash, protrusions, or gate burrs.
4. Strap features may not be present.
5. Reference JEDEC registration MS-026.

EXAMPLE STENCIL DESIGN

PAP0064G

PowerPAD™ TQFP - 1.2 mm max height

PLASTIC QUAD FLATPACK

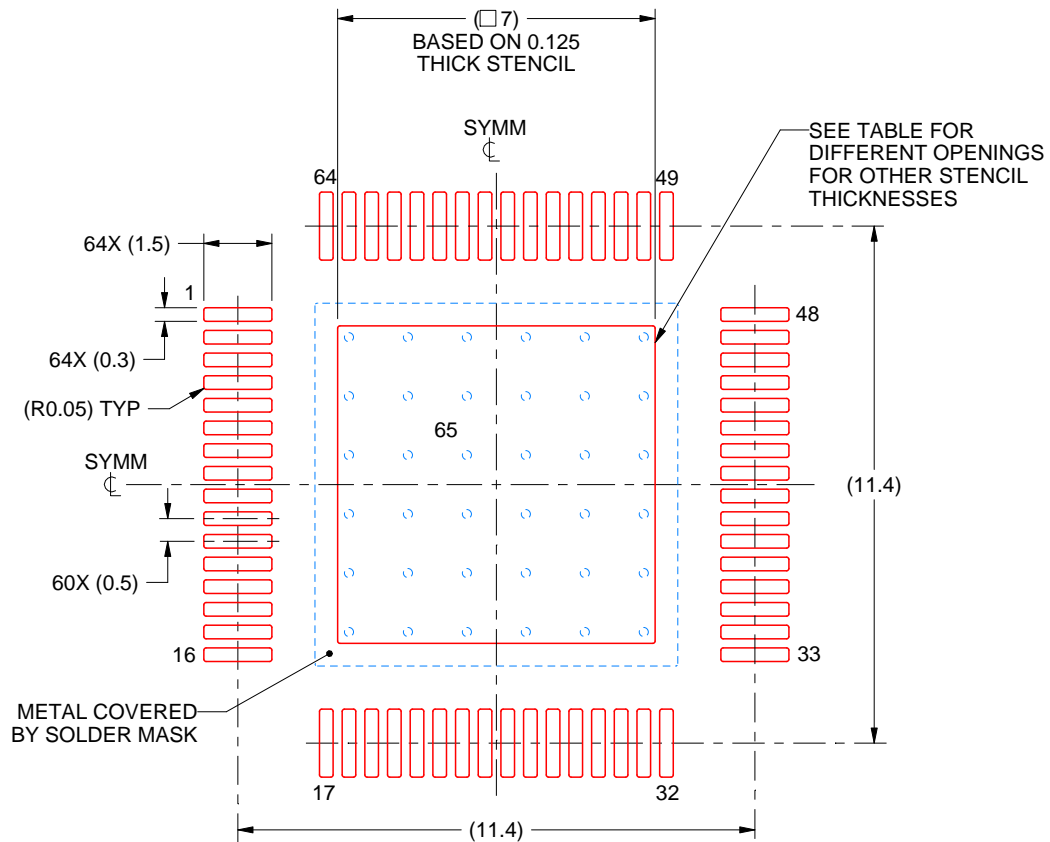

SOLDER PASTE EXAMPLE
 EXPOSED PAD
 100% PRINTED SOLDER COVERAGE BY AREA
 SCALE:6X

STENCIL THICKNESS	SOLDER STENCIL OPENING
0.1	7.83 X 7.83
0.125	7.0 X 7.0 (SHOWN)
0.15	6.39 X 6.39
0.175	5.92 X 5.92

4218924/A 01/2022

NOTES: (continued)

- 11. Laser cutting apertures with trapezoidal walls and rounded corners may offer better paste release. IPC-7525 may have alternate design recommendations.
- 12. Board assembly site may have different recommendations for stencil design.

IMPORTANT NOTICE AND DISCLAIMER

TI PROVIDES TECHNICAL AND RELIABILITY DATA (INCLUDING DATA SHEETS), DESIGN RESOURCES (INCLUDING REFERENCE DESIGNS), APPLICATION OR OTHER DESIGN ADVICE, WEB TOOLS, SAFETY INFORMATION, AND OTHER RESOURCES "AS IS" AND WITH ALL FAULTS, AND DISCLAIMS ALL WARRANTIES, EXPRESS AND IMPLIED, INCLUDING WITHOUT LIMITATION ANY IMPLIED WARRANTIES OF MERCHANTABILITY, FITNESS FOR A PARTICULAR PURPOSE OR NON-INFRINGEMENT OF THIRD PARTY INTELLECTUAL PROPERTY RIGHTS.

These resources are intended for skilled developers designing with TI products. You are solely responsible for (1) selecting the appropriate TI products for your application, (2) designing, validating and testing your application, and (3) ensuring your application meets applicable standards, and any other safety, security, regulatory or other requirements.

These resources are subject to change without notice. TI grants you permission to use these resources only for development of an application that uses the TI products described in the resource. Other reproduction and display of these resources is prohibited. No license is granted to any other TI intellectual property right or to any third party intellectual property right. TI disclaims responsibility for, and you will fully indemnify TI and its representatives against, any claims, damages, costs, losses, and liabilities arising out of your use of these resources.

TI's products are provided subject to [TI's Terms of Sale](#) or other applicable terms available either on ti.com or provided in conjunction with such TI products. TI's provision of these resources does not expand or otherwise alter TI's applicable warranties or warranty disclaimers for TI products.

TI objects to and rejects any additional or different terms you may have proposed.

Mailing Address: Texas Instruments, Post Office Box 655303, Dallas, Texas 75265
Copyright © 2022, Texas Instruments Incorporated

Looking for pricing, stock, or lifecycle information?

Click below to explore more details on WIN SOURCE:

 [View AMC7832IPAPR](#) on WIN SOURCE

 [Texas Instruments](#) Information

Optimize Your Supply Chain with WIN SOURCE Solutions

-  Global Sourcing Solution
-  Obsolete Management
-  Cost Control Management
-  Shortage Management
-  Alternative Solution
-  Excess Inventory Management