



**THE DATASHEET OF
SN74ALVTH162244VR**



SN54ALVTH162244, SN74ALVTH162244 2.5-V/3.3-V 16-BIT BUFFERS/DRIVERS WITH 3-STATE OUTPUTS

SCES074E – JUNE 1996 - REVISED JANUARY 1999

- State-of-the-Art Advanced BiCMOS Technology (ABT) *Widebus*™ Design for 2.5-V and 3.3-V Operation and Low Static Power Dissipation
- Support Mixed-Mode Signal Operation (5-V Input and Output Voltages With 2.3-V to 3.6-V V_{CC})
- Typical V_{OLP} (Output Ground Bounce) < 0.8 V at $V_{CC} = 3.3$ V, $T_A = 25^\circ\text{C}$
- Power Off Disables Outputs, Permitting Live Insertion
- High-Impedance State During Power Up and Power Down Prevents Driver Conflict
- Uses Bus Hold on Data Inputs in Place of External Pullup/Pulldown Resistors to Prevent the Bus From Floating
- Output Ports Have Equivalent 30- Ω Series Resistors, So No External Resistors Are Required
- Auto3-State Eliminates Bus Current Loading When Output Exceeds $V_{CC} + 0.5$ V
- Latch-Up Performance Exceeds 250 mA Per JESD 17
- ESD Protection Exceeds 2000 V Per MIL-STD-883, Method 3015; Exceeds 200 V Using Machine Model; and Exceeds 1000 V Using Charged-Device Model, Robotic Method
- Flow-Through Architecture Facilitates Printed Circuit Board Layout
- Distributed V_{CC} and GND Pin Configuration Minimizes High-Speed Switching Noise
- Package Options Include Plastic Shrink Small-Outline (DL), Thin Shrink Small-Outline (DGG), Thin Very Small-Outline (DGV) Packages, and 380-mil Fine-Pitch Ceramic Flat (WD) Package

SN54ALVTH162244 . . . WD PACKAGE
SN74ALVTH162244 . . . DGG, DGV, OR DL PACKAGE
(TOP VIEW)

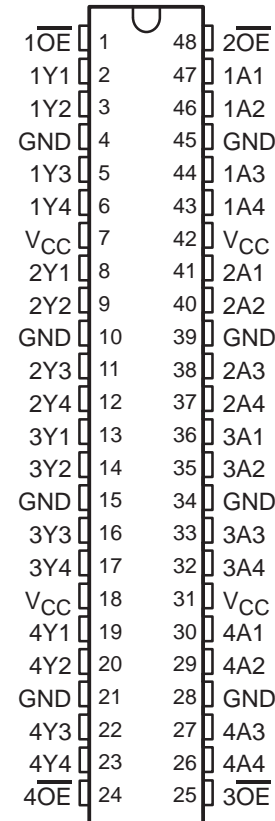

NOTE: For order entry:
The DGG package is abbreviated to G, and
the DGV package is abbreviated to V.

description

The 'ALVTH162244 devices are 16-bit buffers/line drivers designed for low-voltage 2.5-V or 3.3-V V_{CC} operation, but with the capability to provide a TTL interface to a 5-V system environment.



Please be aware that an important notice concerning availability, standard warranty, and use in critical applications of Texas Instruments semiconductor products and disclaimers thereto appears at the end of this data sheet.

Widebus is a trademark of Texas Instruments Incorporated.

UNLESS OTHERWISE NOTED this document contains PRODUCTION DATA information current as of publication date. Products conform to specifications per the terms of Texas Instruments standard warranty. Production processing does not necessarily include testing of all parameters.

 **TEXAS
INSTRUMENTS**

POST OFFICE BOX 655303 • DALLAS, TEXAS 75265

Copyright © 1999, Texas Instruments Incorporated

SN54ALVTH162244, SN74ALVTH162244

2.5-V/3.3-V 16-BIT BUFFERS/DRIVERS

WITH 3-STATE OUTPUTS

SCES074E – JUNE 1996 - REVISED JANUARY 1999

description (continued)

These devices can be used as four 4-bit buffers, two 8-bit buffers, or one 16-bit buffer. These devices provide true outputs and symmetrical active-low output-enable (\overline{OE}) inputs.

Active bus-hold circuitry is provided to hold unused or floating data inputs at a valid logic level.

When V_{CC} is between 0 and 1.2 V, the device is in the high-impedance state during power up or power down. However, to ensure the high-impedance state above 1.2 V, \overline{OE} should be tied to V_{CC} through a pullup resistor; the minimum value of the resistor is determined by the current-sinking capability of the driver.

All outputs are designed to sink up to 12 mA and include equivalent 30- Ω resistors to reduce overshoot and undershoot.

The SN54ALVTH162244 is characterized for operation over the full military temperature range of -55°C to 125°C . The SN74ALVTH162244 is characterized for operation from -40°C to 85°C .

FUNCTION TABLE
(each 4-bit buffer)

INPUTS		OUTPUT
\overline{OE}	A	Y
L	H	H
L	L	L
H	X	Z

logic diagram (positive logic)

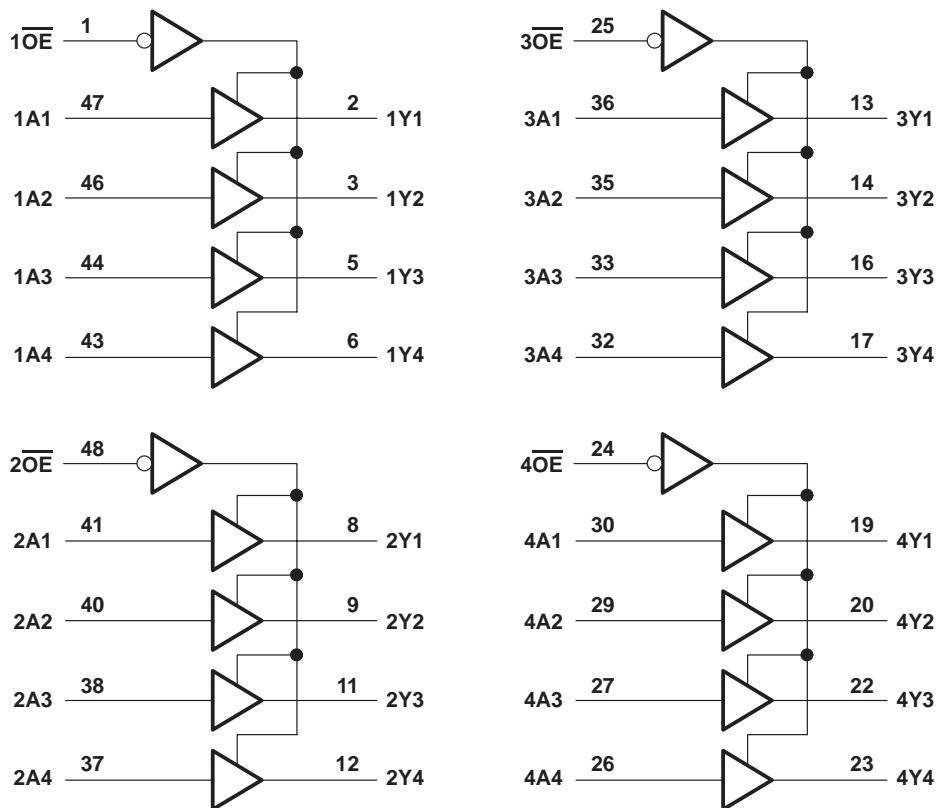

SN54ALVTH162244, SN74ALVTH162244

2.5-V/3.3-V 16-BIT BUFFERS/DRIVERS

WITH 3-STATE OUTPUTS

SCES074E – JUNE 1996 - REVISED JANUARY 1999

electrical characteristics over recommended operating free-air temperature range,
 $V_{CC} = 2.5\text{ V} \pm 0.2\text{ V}$ (unless otherwise noted)

PARAMETER	TEST CONDITIONS	SN54ALVTH162244		SN74ALVTH162244		UNIT	
		MIN	TYP†	MAX	MIN		TYP†
V_{IK}	$V_{CC} = 2.3\text{ V}$, $I_I = -18\text{ mA}$			-1.2		-1.2	V
V_{OH}	$V_{CC} = 2.3\text{ V to } 2.7\text{ V}$, $I_{OH} = -100\text{ }\mu\text{A}$	$V_{CC}-0.2$		$V_{CC}-0.2$			V
	$V_{CC} = 2.3\text{ V}$	1.7		1.7			
V_{OL}	$V_{CC} = 2.3\text{ V to } 2.7\text{ V}$, $I_{OL} = 100\text{ }\mu\text{A}$	0.2		0.2			V
	$V_{CC} = 2.3\text{ V}$	0.7		0.7			
		0.7		0.7			
I_I	Control inputs	$V_{CC} = 2.7\text{ V}$, $V_I = V_{CC}\text{ or GND}$	± 1		± 1		μA
		$V_{CC} = 0\text{ or } 2.7\text{ V}$, $V_I = 5.5\text{ V}$	10		10		
	Data inputs	$V_{CC} = 2.7\text{ V}$	10		10		
			1		1		
		-5		-5			
I_{off}	$V_{CC} = 0$, $V_I\text{ or } V_O = 0\text{ to } 4.5\text{ V}$			± 100		μA	
I_{BHL}^\ddagger	$V_{CC} = 2.3\text{ V}$, $V_I = 0.7\text{ V}$	115		115		μA	
I_{BHH}^\S	$V_{CC} = 2.3\text{ V}$, $V_I = 1.7\text{ V}$	-10		-10		μA	
I_{BHLO}^\P	$V_{CC} = 2.7\text{ V}$, $V_I = 0\text{ to } V_{CC}$	300		300		μA	
$I_{BHHO}^\#$	$V_{CC} = 2.7\text{ V}$, $V_I = 0\text{ to } V_{CC}$	-300		-300		μA	
I_{EX}^\parallel	$V_{CC} = 2.3\text{ V}$, $V_O = 5.5\text{ V}$	125		125		μA	
$I_{OZ(PU/PD)}^\star$	$V_{CC} \leq 1.2\text{ V}$, $V_O = 0.5\text{ V to } V_{CC}$, $V_I = \text{GND or } V_{CC}$, $\overline{OE} = \text{don't care}$	± 100		± 100		μA	
I_{OZH}	$V_{CC} = 2.7\text{ V}$	5		5		μA	
I_{OZL}	$V_{CC} = 2.7\text{ V}$	-5		-5		μA	
I_{CC}	$V_{CC} = 2.7\text{ V}$, $I_O = 0$, $V_I = V_{CC}\text{ or GND}$	Outputs high	0.04	0.1	0.04	0.1	mA
		Outputs low	2.3	4.5	2.3	4.5	
		Outputs disabled	0.04	0.1	0.04	0.1	
C_i	$V_{CC} = 2.5\text{ V}$, $V_I = 2.5\text{ V or } 0$	3		3		pF	
C_o	$V_{CC} = 2.5\text{ V}$, $V_O = 2.5\text{ V or } 0$	6		6		pF	

† All typical values are at $V_{CC} = 2.5\text{ V}$, $T_A = 25^\circ\text{C}$.

‡ The bus-hold circuit can sink at least the minimum low sustaining current at $V_{IL}\text{ max}$. I_{BHL} should be measured after lowering V_{IN} to GND and then raising it to $V_{IL}\text{ max}$.

§ The bus-hold circuit can source at least the minimum high sustaining current at $V_{IH}\text{ min}$. I_{BHH} should be measured after raising V_{IN} to V_{CC} and then lowering it to $V_{IH}\text{ min}$.

¶ An external driver must source at least I_{BHLO} to switch this node from low to high.

An external driver must sink at least I_{BHHO} to switch this node from high to low.

|| Current into an output in the high state when $V_O > V_{CC}$

☆ High-impedance state during power up or power down

SN54ALVTH162244, SN74ALVTH162244
2.5-V/3.3-V 16-BIT BUFFERS/DRIVERS
WITH 3-STATE OUTPUTS

SCES074E – JUNE 1996 - REVISED JANUARY 1999

electrical characteristics over recommended operating free-air temperature range,
 $V_{CC} = 3.3 \text{ V} \pm 0.3 \text{ V}$ (unless otherwise noted)

PARAMETER		TEST CONDITIONS	SN54ALVTH162244		SN74ALVTH162244		UNIT		
			MIN	TYP†	MAX	MIN		TYP†	MAX
V_{IK}		$V_{CC} = 3 \text{ V}$, $I_I = -18 \text{ mA}$			-1.2		-1.2	V	
V_{OH}		$V_{CC} = 3 \text{ V to } 3.6 \text{ V}$, $I_{OH} = -100 \mu\text{A}$	$V_{CC}-0.2$		$V_{CC}-0.2$			V	
		$V_{CC} = 3 \text{ V}$, $I_{OH} = -8 \text{ mA}$	2						
V_{OL}		$V_{CC} = 3 \text{ V to } 3.6 \text{ V}$, $I_{OL} = 100 \mu\text{A}$			0.2		0.2	V	
		$V_{CC} = 3 \text{ V}$, $I_{OL} = 8 \text{ mA}$			0.8				
		$V_{CC} = 3 \text{ V}$, $I_{OL} = 12 \text{ mA}$					0.8		
I_I	Control inputs	$V_{CC} = 3.6 \text{ V}$, $V_I = V_{CC} \text{ or GND}$			± 1		± 1	μA	
		$V_{CC} = 0 \text{ or } 3.6 \text{ V}$, $V_I = 5.5 \text{ V}$			10		10		
	Data inputs	$V_{CC} = 3.6 \text{ V}$, $V_I = 5.5 \text{ V}$			10		10		
		$V_{CC} = 3.6 \text{ V}$, $V_I = V_{CC}$			1		1		
	$V_{CC} = 3.6 \text{ V}$, $V_I = 0$			-5		-5			
I_{off}		$V_{CC} = 0$, $V_I \text{ or } V_O = 0 \text{ to } 4.5 \text{ V}$					± 100	μA	
I_{BHL}^\ddagger		$V_{CC} = 3 \text{ V}$, $V_I = 0.8 \text{ V}$	75		75		μA		
I_{BHH}^\S		$V_{CC} = 3 \text{ V}$, $V_I = 2 \text{ V}$	-75		-75		μA		
I_{BHLO}^\parallel		$V_{CC} = 3.6 \text{ V}$, $V_I = 0 \text{ to } V_{CC}$	500		500		μA		
$I_{BHHO}^\#$		$V_{CC} = 3.6 \text{ V}$, $V_I = 0 \text{ to } V_{CC}$	-500		-500		μA		
I_{EX}^{\parallel}		$V_{CC} = 3 \text{ V}$, $V_O = 5.5 \text{ V}$			125		125	μA	
$I_{OZ(PU/PD)}^\star$		$V_{CC} \leq 1.2 \text{ V}$, $V_O = 0.5 \text{ V to } V_{CC}$, $V_I = \text{GND or } V_{CC}$, $\overline{OE} = \text{don't care}$			± 100		± 100	μA	
I_{OZH}		$V_{CC} = 3.6 \text{ V}$, $V_O = 3 \text{ V}$, $V_I = 0.8 \text{ V or } 2 \text{ V}$			5		5	μA	
I_{OZL}		$V_{CC} = 3.6 \text{ V}$, $V_O = 0.5 \text{ V}$, $V_I = 0.8 \text{ V or } 2 \text{ V}$			-5		-5	μA	
I_{CC}		$V_{CC} = 3.6 \text{ V}$, $I_O = 0$, $V_I = V_{CC} \text{ or GND}$	Outputs high		0.07	0.1	0.07	0.1	mA
			Outputs low		3.2	5	3.2	5	
			Outputs disabled		0.07	0.1	0.07	0.1	
ΔI_{CC}^\square		$V_{CC} = 3 \text{ V to } 3.6 \text{ V}$, One input at $V_{CC} - 0.6 \text{ V}$, Other inputs at $V_{CC} \text{ or GND}$			0.4		0.4	mA	
C_i		$V_{CC} = 3.3 \text{ V}$, $V_I = 3.3 \text{ V or } 0$			3		3	pF	
C_o		$V_{CC} = 3.3 \text{ V}$, $V_O = 3.3 \text{ V or } 0$			6		6	pF	

† All typical values are at $V_{CC} = 3.3 \text{ V}$, $T_A = 25^\circ\text{C}$.

‡ The bus-hold circuit can sink at least the minimum low sustaining current at V_{IL} max. I_{BHL} should be measured after lowering V_{IN} to GND and then raising it to V_{IL} max.

§ The bus-hold circuit can source at least the minimum high sustaining current at V_{IH} min. I_{BHH} should be measured after raising V_{IN} to V_{CC} and then lowering it to V_{IH} min.

¶ An external driver must source at least I_{BHLO} to switch this node from low to high.

An external driver must sink at least I_{BHHO} to switch this node from high to low.

|| Current into an output in the high state when $V_O > V_{CC}$

☆ High-impedance state during power up or power down

□ This is the increase in supply current for each input that is at the specified TTL voltage level rather than V_{CC} or GND.

SN54ALVTH162244, SN74ALVTH162244
2.5-V/3.3-V 16-BIT BUFFERS/DRIVERS
WITH 3-STATE OUTPUTS

SCES074E – JUNE 1996 - REVISED JANUARY 1999

switching characteristics over recommended operating free-air temperature range, $C_L = 30 \text{ pF}$, $V_{CC} = 2.5 \text{ V} \pm 0.2 \text{ V}$ (unless otherwise noted) (see Figure 1)

PARAMETER	FROM (INPUT)	TO (OUTPUT)	SN54ALVTH162244		SN74ALVTH162244		UNIT
			MIN	MAX	MIN	MAX	
t_{PLH}	A	Y	1	4.3	1	4.2	ns
t_{PHL}			1.4	3.8	1.5	3.7	
t_{PZH}	\overline{OE}	Y	1.3	6.9	1.4	6.8	ns
t_{PZL}			1.3	5.2	1.4	5.1	
t_{PHZ}	\overline{OE}	Y	1	4.7	1	4.6	ns
t_{PLZ}			1	3.6	1	3.5	

switching characteristics over recommended operating free-air temperature range, $C_L = 50 \text{ pF}$, $V_{CC} = 3.3 \text{ V} \pm 0.3 \text{ V}$ (unless otherwise noted) (see Figure 2)

PARAMETER	FROM (INPUT)	TO (OUTPUT)	SN54ALVTH162244		SN74ALVTH162244		UNIT
			MIN	MAX	MIN	MAX	
t_{PLH}	A	Y	1	3.4	1	3.3	ns
t_{PHL}			1	3.4	1	3.3	
t_{PZH}	\overline{OE}	Y	1.4	5	1.5	4.9	ns
t_{PZL}			1.3	3.4	1.4	3.3	
t_{PHZ}	\overline{OE}	Y	1.4	5	1.5	4.9	ns
t_{PLZ}			1.4	4.4	1.5	4.3	

PRODUCT PREVIEW information concerns products in the formative or design phase of development. Characteristic data and other specifications are design goals. Texas Instruments reserves the right to change or discontinue these products without notice.



POST OFFICE BOX 655303 • DALLAS, TEXAS 75265

PARAMETER MEASUREMENT INFORMATION

$V_{CC} = 2.5\text{ V} \pm 0.2\text{ V}$

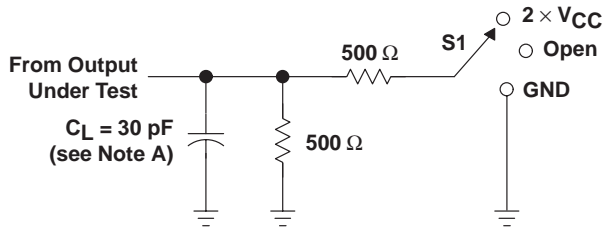

LOAD CIRCUIT

TEST	S1
t_{PLH}/t_{PHL}	Open
t_{PLZ}/t_{PZL}	2 $\times V_{CC}$
t_{PHZ}/t_{PZH}	GND

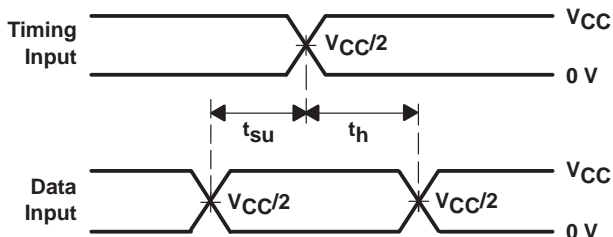

VOLTAGE WAVEFORMS
 SETUP AND HOLD TIMES

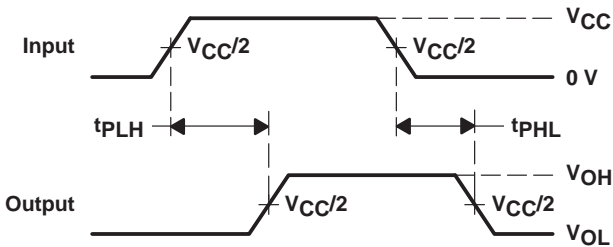

VOLTAGE WAVEFORMS
 PROPAGATION DELAY TIMES

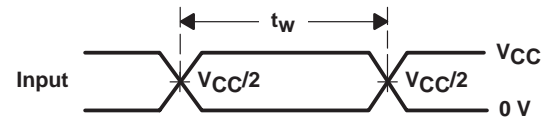

VOLTAGE WAVEFORMS
 PULSE DURATION

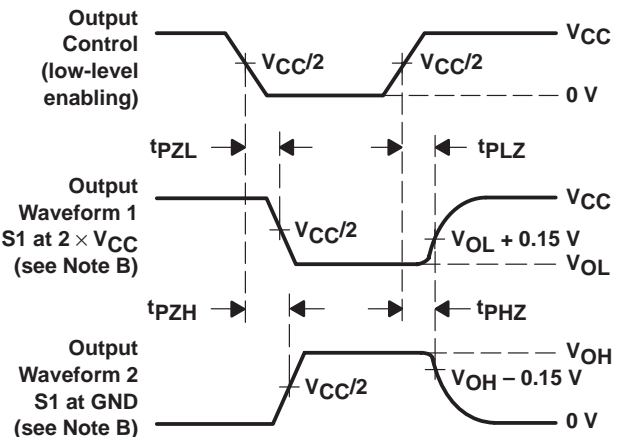

VOLTAGE WAVEFORMS
 ENABLE AND DISABLE TIMES

- NOTES: A. C_L includes probe and jig capacitance.
 B. Waveform 1 is for an output with internal conditions such that the output is low except when disabled by the output control. Waveform 2 is for an output with internal conditions such that the output is high except when disabled by the output control.
 C. All input pulses are supplied by generators having the following characteristics: PRR $\leq 10\text{ MHz}$, $Z_O = 50\ \Omega$, $t_r \leq 2\text{ ns}$, $t_f \leq 2\text{ ns}$.
 D. The outputs are measured one at a time with one transition per measurement.

Figure 1. Load Circuit and Voltage Waveforms

SN54ALVTH162244, SN74ALVTH162244
2.5-V/3.3-V 16-BIT BUFFERS/DRIVERS
WITH 3-STATE OUTPUTS

SCES074E – JUNE 1996 - REVISED JANUARY 1999

PARAMETER MEASUREMENT INFORMATION

$V_{CC} = 3.3\text{ V} \pm 0.3\text{ V}$

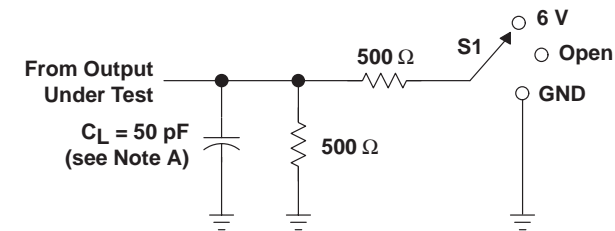

LOAD CIRCUIT

TEST	S1
t_{PLH}/t_{PHL}	Open
t_{PLZ}/t_{PZL}	6 V
t_{PHZ}/t_{PZH}	GND

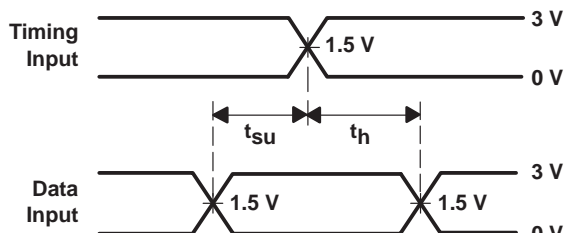

**VOLTAGE WAVEFORMS
SETUP AND HOLD TIMES**

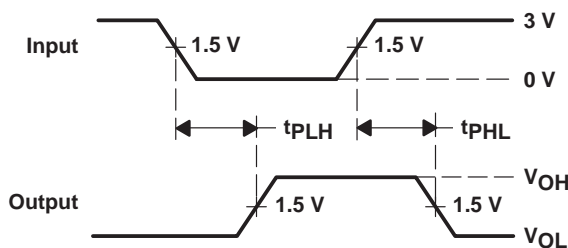

**VOLTAGE WAVEFORMS
PROPAGATION DELAY TIMES
INVERTING AND NONINVERTING OUTPUTS**

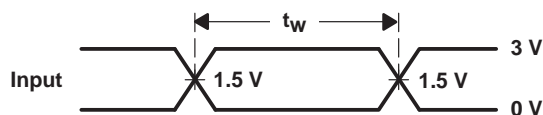

**VOLTAGE WAVEFORMS
PULSE DURATION**

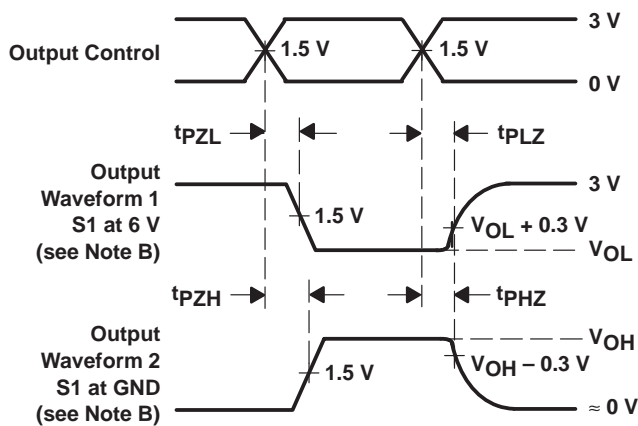

**VOLTAGE WAVEFORMS
ENABLE AND DISABLE TIMES
LOW- AND HIGH-LEVEL ENABLING**

- NOTES: A. C_L includes probe and jig capacitance.
 B. Waveform 1 is for an output with internal conditions such that the output is low except when disabled by the output control. Waveform 2 is for an output with internal conditions such that the output is high except when disabled by the output control.
 C. All input pulses are supplied by generators having the following characteristics: $PRR \leq 10\text{ MHz}$, $Z_O = 50\ \Omega$, $t_r \leq 2.5\text{ ns}$, $t_f \leq 2.5\text{ ns}$.
 D. The outputs are measured one at a time with one transition per measurement.

Figure 2. Load Circuit and Voltage Waveforms

PACKAGING INFORMATION

Orderable Device	Status (1)	Package Type	Package Drawing	Pins	Package Qty	Eco Plan (2)	Lead/Ball Finish (6)	MSL Peak Temp (3)	Op Temp (°C)	Device Marking (4/5)	Samples
SN74ALVTH162244DL	ACTIVE	SSOP	DL	48	25	Green (RoHS & no Sb/Br)	CU NIPDAU	Level-1-260C-UNLIM	-40 to 85	ALVTH162244	Samples
SN74ALVTH162244GR	ACTIVE	TSSOP	DGG	48	2000	Green (RoHS & no Sb/Br)	CU NIPDAU	Level-1-260C-UNLIM	-40 to 85	ALVTH162244	Samples
SN74ALVTH162244LR	ACTIVE	SSOP	DL	48	1000	Green (RoHS & no Sb/Br)	CU NIPDAU	Level-1-260C-UNLIM	-40 to 85	ALVTH162244	Samples
SN74ALVTH162244VR	ACTIVE	TVSOP	DGV	48	2000	Green (RoHS & no Sb/Br)	CU NIPDAU	Level-1-260C-UNLIM	-40 to 85	VT2244	Samples

(1) The marketing status values are defined as follows:

ACTIVE: Product device recommended for new designs.

LIFEBUY: TI has announced that the device will be discontinued, and a lifetime-buy period is in effect.

NRND: Not recommended for new designs. Device is in production to support existing customers, but TI does not recommend using this part in a new design.

PREVIEW: Device has been announced but is not in production. Samples may or may not be available.

OBSELETE: TI has discontinued the production of the device.

(2) Eco Plan - The planned eco-friendly classification: Pb-Free (RoHS), Pb-Free (RoHS Exempt), or Green (RoHS & no Sb/Br) - please check <http://www.ti.com/productcontent> for the latest availability information and additional product content details.

TBD: The Pb-Free/Green conversion plan has not been defined.

Pb-Free (RoHS): TI's terms "Lead-Free" or "Pb-Free" mean semiconductor products that are compatible with the current RoHS requirements for all 6 substances, including the requirement that lead not exceed 0.1% by weight in homogeneous materials. Where designed to be soldered at high temperatures, TI Pb-Free products are suitable for use in specified lead-free processes.

Pb-Free (RoHS Exempt): This component has a RoHS exemption for either 1) lead-based flip-chip solder bumps used between the die and package, or 2) lead-based die adhesive used between the die and leadframe. The component is otherwise considered Pb-Free (RoHS compatible) as defined above.

Green (RoHS & no Sb/Br): TI defines "Green" to mean Pb-Free (RoHS compatible), and free of Bromine (Br) and Antimony (Sb) based flame retardants (Br or Sb do not exceed 0.1% by weight in homogeneous material)

(3) MSL, Peak Temp. - The Moisture Sensitivity Level rating according to the JEDEC industry standard classifications, and peak solder temperature.

(4) There may be additional marking, which relates to the logo, the lot trace code information, or the environmental category on the device.

(5) Multiple Device Markings will be inside parentheses. Only one Device Marking contained in parentheses and separated by a "~" will appear on a device. If a line is indented then it is a continuation of the previous line and the two combined represent the entire Device Marking for that device.

(6) Lead/Ball Finish - Orderable Devices may have multiple material finish options. Finish options are separated by a vertical ruled line. Lead/Ball Finish values may wrap to two lines if the finish value exceeds the maximum column width.

Important Information and Disclaimer: The information provided on this page represents TI's knowledge and belief as of the date that it is provided. TI bases its knowledge and belief on information provided by third parties, and makes no representation or warranty as to the accuracy of such information. Efforts are underway to better integrate information from third parties. TI has taken and continues to take reasonable steps to provide representative and accurate information but may not have conducted destructive testing or chemical analysis on incoming materials and chemicals. TI and TI suppliers consider certain information to be proprietary, and thus CAS numbers and other limited information may not be available for release.

In no event shall TI's liability arising out of such information exceed the total purchase price of the TI part(s) at issue in this document sold by TI to Customer on an annual basis.

TAPE AND REEL INFORMATION

QUADRANT ASSIGNMENTS FOR PIN 1 ORIENTATION IN TAPE

*All dimensions are nominal

Device	Package Type	Package Drawing	Pins	SPQ	Reel Diameter (mm)	Reel Width W1 (mm)	A0 (mm)	B0 (mm)	K0 (mm)	P1 (mm)	W (mm)	Pin1 Quadrant
SN74ALVTH162244GR	TSSOP	DGG	48	2000	330.0	24.4	8.6	13.0	1.8	12.0	24.0	Q1
SN74ALVTH162244LR	SSOP	DL	48	1000	330.0	32.4	11.35	16.2	3.1	16.0	32.0	Q1
SN74ALVTH162244VR	TVSOP	DGV	48	2000	330.0	16.4	7.1	10.2	1.6	12.0	16.0	Q1

TAPE AND REEL BOX DIMENSIONS



*All dimensions are nominal

Device	Package Type	Package Drawing	Pins	SPQ	Length (mm)	Width (mm)	Height (mm)
SN74ALVTH162244GR	TSSOP	DGG	48	2000	367.0	367.0	45.0
SN74ALVTH162244LR	SSOP	DL	48	1000	367.0	367.0	55.0
SN74ALVTH162244VR	TVSOP	DGV	48	2000	367.0	367.0	38.0

MECHANICAL DATA

DL (R-PDSO-G48)

PLASTIC SMALL-OUTLINE PACKAGE



- NOTES:
- All linear dimensions are in inches (millimeters).
 - This drawing is subject to change without notice.
 - Body dimensions do not include mold flash or protrusion not to exceed 0.006 (0,15).
 - Falls within JEDEC MO-118

PowerPAD is a trademark of Texas Instruments.

DGV (R-PDSO-G**)

PLASTIC SMALL-OUTLINE

24 PINS SHOWN



- NOTES: A. All linear dimensions are in millimeters.
 B. This drawing is subject to change without notice.
 C. Body dimensions do not include mold flash or protrusion, not to exceed 0,15 per side.
 D. Falls within JEDEC: 24/48 Pins – MO-153
 14/16/20/56 Pins – MO-194

DGG (R-PDSO-G**)

PLASTIC SMALL-OUTLINE PACKAGE

48 PINS SHOWN



- NOTES: A. All linear dimensions are in millimeters.
 B. This drawing is subject to change without notice.
 C. Body dimensions do not include mold protrusion not to exceed 0,15.
 D. Falls within JEDEC MO-153

IMPORTANT NOTICE

Texas Instruments Incorporated (TI) reserves the right to make corrections, enhancements, improvements and other changes to its semiconductor products and services per JESD46, latest issue, and to discontinue any product or service per JESD48, latest issue. Buyers should obtain the latest relevant information before placing orders and should verify that such information is current and complete.

TI's published terms of sale for semiconductor products (<http://www.ti.com/sc/docs/stdterms.htm>) apply to the sale of packaged integrated circuit products that TI has qualified and released to market. Additional terms may apply to the use or sale of other types of TI products and services.

Reproduction of significant portions of TI information in TI data sheets is permissible only if reproduction is without alteration and is accompanied by all associated warranties, conditions, limitations, and notices. TI is not responsible or liable for such reproduced documentation. Information of third parties may be subject to additional restrictions. Resale of TI products or services with statements different from or beyond the parameters stated by TI for that product or service voids all express and any implied warranties for the associated TI product or service and is an unfair and deceptive business practice. TI is not responsible or liable for any such statements.

Buyers and others who are developing systems that incorporate TI products (collectively, "Designers") understand and agree that Designers remain responsible for using their independent analysis, evaluation and judgment in designing their applications and that Designers have full and exclusive responsibility to assure the safety of Designers' applications and compliance of their applications (and of all TI products used in or for Designers' applications) with all applicable regulations, laws and other applicable requirements. Designer represents that, with respect to their applications, Designer has all the necessary expertise to create and implement safeguards that (1) anticipate dangerous consequences of failures, (2) monitor failures and their consequences, and (3) lessen the likelihood of failures that might cause harm and take appropriate actions. Designer agrees that prior to using or distributing any applications that include TI products, Designer will thoroughly test such applications and the functionality of such TI products as used in such applications.

TI's provision of technical, application or other design advice, quality characterization, reliability data or other services or information, including, but not limited to, reference designs and materials relating to evaluation modules, (collectively, "TI Resources") are intended to assist designers who are developing applications that incorporate TI products; by downloading, accessing or using TI Resources in any way, Designer (individually or, if Designer is acting on behalf of a company, Designer's company) agrees to use any particular TI Resource solely for this purpose and subject to the terms of this Notice.

TI's provision of TI Resources does not expand or otherwise alter TI's applicable published warranties or warranty disclaimers for TI products, and no additional obligations or liabilities arise from TI providing such TI Resources. TI reserves the right to make corrections, enhancements, improvements and other changes to its TI Resources. TI has not conducted any testing other than that specifically described in the published documentation for a particular TI Resource.

Designer is authorized to use, copy and modify any individual TI Resource only in connection with the development of applications that include the TI product(s) identified in such TI Resource. NO OTHER LICENSE, EXPRESS OR IMPLIED, BY ESTOPPEL OR OTHERWISE TO ANY OTHER TI INTELLECTUAL PROPERTY RIGHT, AND NO LICENSE TO ANY TECHNOLOGY OR INTELLECTUAL PROPERTY RIGHT OF TI OR ANY THIRD PARTY IS GRANTED HEREIN, including but not limited to any patent right, copyright, mask work right, or other intellectual property right relating to any combination, machine, or process in which TI products or services are used. Information regarding or referencing third-party products or services does not constitute a license to use such products or services, or a warranty or endorsement thereof. Use of TI Resources may require a license from a third party under the patents or other intellectual property of the third party, or a license from TI under the patents or other intellectual property of TI.

TI RESOURCES ARE PROVIDED "AS IS" AND WITH ALL FAULTS. TI DISCLAIMS ALL OTHER WARRANTIES OR REPRESENTATIONS, EXPRESS OR IMPLIED, REGARDING RESOURCES OR USE THEREOF, INCLUDING BUT NOT LIMITED TO ACCURACY OR COMPLETENESS, TITLE, ANY EPIDEMIC FAILURE WARRANTY AND ANY IMPLIED WARRANTIES OF MERCHANTABILITY, FITNESS FOR A PARTICULAR PURPOSE, AND NON-INFRINGEMENT OF ANY THIRD PARTY INTELLECTUAL PROPERTY RIGHTS. TI SHALL NOT BE LIABLE FOR AND SHALL NOT DEFEND OR INDEMNIFY DESIGNER AGAINST ANY CLAIM, INCLUDING BUT NOT LIMITED TO ANY INFRINGEMENT CLAIM THAT RELATES TO OR IS BASED ON ANY COMBINATION OF PRODUCTS EVEN IF DESCRIBED IN TI RESOURCES OR OTHERWISE. IN NO EVENT SHALL TI BE LIABLE FOR ANY ACTUAL, DIRECT, SPECIAL, COLLATERAL, INDIRECT, PUNITIVE, INCIDENTAL, CONSEQUENTIAL OR EXEMPLARY DAMAGES IN CONNECTION WITH OR ARISING OUT OF TI RESOURCES OR USE THEREOF, AND REGARDLESS OF WHETHER TI HAS BEEN ADVISED OF THE POSSIBILITY OF SUCH DAMAGES.

Unless TI has explicitly designated an individual product as meeting the requirements of a particular industry standard (e.g., ISO/TS 16949 and ISO 26262), TI is not responsible for any failure to meet such industry standard requirements.

Where TI specifically promotes products as facilitating functional safety or as compliant with industry functional safety standards, such products are intended to help enable customers to design and create their own applications that meet applicable functional safety standards and requirements. Using products in an application does not by itself establish any safety features in the application. Designers must ensure compliance with safety-related requirements and standards applicable to their applications. Designer may not use any TI products in life-critical medical equipment unless authorized officers of the parties have executed a special contract specifically governing such use. Life-critical medical equipment is medical equipment where failure of such equipment would cause serious bodily injury or death (e.g., life support, pacemakers, defibrillators, heart pumps, neurostimulators, and implantables). Such equipment includes, without limitation, all medical devices identified by the U.S. Food and Drug Administration as Class III devices and equivalent classifications outside the U.S.

TI may expressly designate certain products as completing a particular qualification (e.g., Q100, Military Grade, or Enhanced Product). Designers agree that it has the necessary expertise to select the product with the appropriate qualification designation for their applications and that proper product selection is at Designers' own risk. Designers are solely responsible for compliance with all legal and regulatory requirements in connection with such selection.

Designer will fully indemnify TI and its representatives against any damages, costs, losses, and/or liabilities arising out of Designer's non-compliance with the terms and provisions of this Notice.

Looking for pricing, stock, or lifecycle information?

Click below to explore more details on WIN SOURCE:

 [View SN74ALVTH162244VR on WIN SOURCE](#)

 [Texas Instruments](#) Information

Optimize Your Supply Chain with WIN SOURCE Solutions

-  Global Sourcing Solution
-  Obsolete Management
-  Cost Control Management
-  Shortage Management
-  Alternative Solution
-  Excess Inventory Management