



**THE DATASHEET OF
CY7C1041CV33-12BAXE**



Features

- Temperature ranges
 - Automotive-A: -40 °C to 85 °C
 - Automotive-E: -40 °C to 125 °C
- Pin and function compatible with CY7C1041BNV33
- High speed
 - $t_{AA} = 10$ ns (Automotive-A)
 - $t_{AA} = 10$ ns (Automotive-E)
- Low active power
 - 432 mW (max)
- Automatic power down when deselected
- TTL-compatible inputs and outputs
- Easy memory expansion with \overline{CE} and \overline{OE} features
- Available in Pb-free and non Pb-free 44-pin 400 Mil SOJ, 44-pin TSOP II and 48-ball FBGA packages

Functional Description

The CY7C1041CV33 Automotive is a high performance CMOS static RAM organized as 262,144 words by 16 bits.

To write to the device, take Chip Enable (\overline{CE}) and Write Enable (\overline{WE}) inputs LOW. If Byte Low Enable (\overline{BLE}) is LOW, then data from I/O pins (I/O_0 through I/O_7), is written into the location specified on the address pins (A_0 through A_{17}). If Byte High Enable (\overline{BHE}) is LOW, then data from I/O pins (I/O_8 through I/O_{15}) is written into the location specified on the address pins (A_0 through A_{17}).

To read from the device, take Chip Enable (\overline{CE}) and Output Enable (\overline{OE}) LOW while forcing the Write Enable (\overline{WE}) HIGH. If Byte Low Enable (\overline{BLE}) is LOW, then data from the memory location specified by the address pins appear on I/O_0 to I/O_7 . If Byte High Enable (\overline{BHE}) is LOW, then data from memory appears on I/O_8 to I/O_{15} . For more information, see the [Truth Table on page 11](#) for a complete description of Read and Write modes.

The input and output pins (I/O_0 through I/O_{15}) are placed in a high impedance state when the device is deselected (\overline{CE} HIGH), the outputs are disabled (\overline{OE} HIGH), the \overline{BHE} and \overline{BLE} are disabled (\overline{BHE} , \overline{BLE} HIGH), or during a write operation (\overline{CE} LOW and \overline{WE} LOW).

Logic Block Diagram

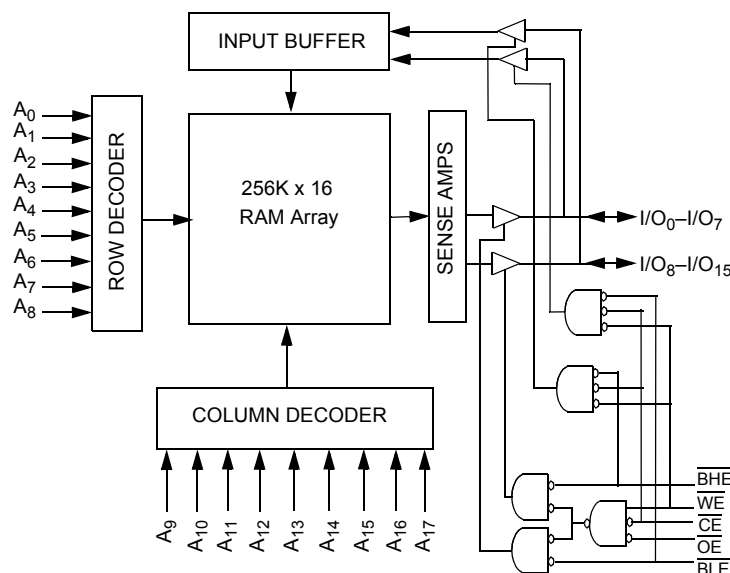

Contents

Selection Guide	3	Package Diagrams	13
Pin Configuration	3	Acronyms	16
Pin Definitions	4	Document Conventions	16
Maximum Ratings	5	Units of Measure	16
Operating Range	5	Document History Page	17
Electrical Characteristics	5	Sales, Solutions, and Legal Information	18
Capacitance	6	Worldwide Sales and Design Support	18
Thermal Resistance	6	Products	18
AC Test Loads and Waveforms	6	PSoC® Solutions	18
Switching Characteristics	7	Cypress Developer Community	18
Switching Waveforms	8	Technical Support	18
Truth Table	11		
Ordering Information	12		
Ordering Code Definitions	12		

Selection Guide

Description		-10	-12	-20	Unit
Maximum Access Time		10	12	20	ns
Maximum Operating Current	Automotive-A	100	–	85	mA
	Automotive-E	130	120	90	mA
Maximum CMOS Standby Current	Automotive-A	10	–	10	mA
	Automotive-E	15	15	15	mA

Pin Configuration

Figure 1. 44-pin SOJ/TSOP II pinout (Top View) ^[1]

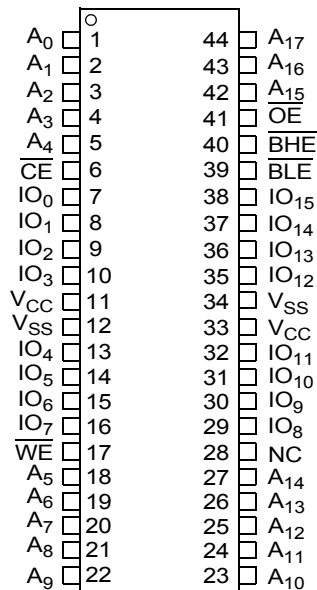
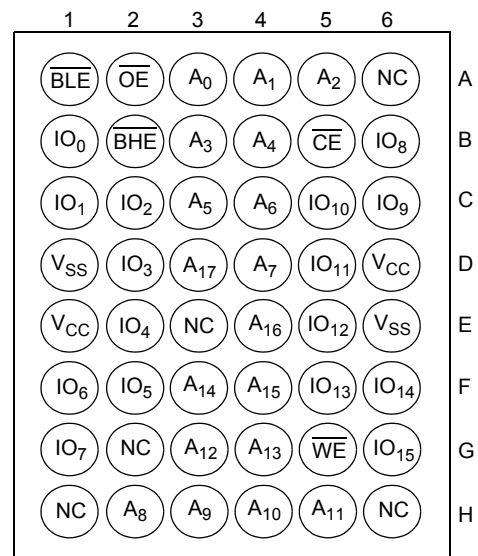

Figure 2. 48-ball FBGA pinout (Top View) ^[1]



Note

1. NC pins are not connected on the die.

Pin Definitions

Pin Name	SOJ, TSOP Pin Number	BGA Pin Number	I/O Type	Description
A ₀ -A ₁₇	1-5, 18-27, 42-44	A3, A4, A5, B3, B4, C3, C4, D4, H2, H3, H4, H5, G3, G4, F3, F4, E4, D3	Input	Address Inputs. Used to select one of the address locations.
I/O ₀ -I/O ₁₅	7-10, 13-16, 29-32, 35-38	B1, C1, C2, D2, E2, F2, F1, G1, B6, C6, C5, D5, E5, F5, F6, G6	Input or Output	Bidirectional Data I/O lines. Used as input or output lines depending on operation.
NC	28	A6, E3, G2, H1, H6	No Connect	No Connects. Not connected to the die.
$\overline{\text{WE}}$	17	G5	Input or Control	Write Enable Input, Active LOW. When selected LOW, a write is conducted. When deselected HIGH, a read is conducted.
$\overline{\text{CE}}$	6	B5	Input or Control	Chip Enable Input, Active LOW. When LOW, selects the chip. When HIGH, deselects the chip.
$\overline{\text{BHE}}, \overline{\text{BLE}}$	40, 39	B2, A1	Input or Control	Byte Write Select Inputs, Active LOW. $\overline{\text{BHE}}$ controls I/O ₁₅ -I/O ₈ , $\overline{\text{BLE}}$ controls I/O ₇ -I/O ₀ .
$\overline{\text{OE}}$	41	A2	Input or Control	Output Enable, Active LOW. Controls the direction of the I/O pins. When LOW, the I/O pins are allowed to behave as outputs. When deasserted HIGH, the I/O pins are tri-stated and act as input data pins.
V _{SS}	12, 34	D1, E6	Ground	Ground for the Device. Connected to ground of the system.
V _{CC}	11, 33	D6, E1	Power Supply	Power Supply Inputs to the Device.

Maximum Ratings

Exceeding maximum ratings may impair the useful life of the device. These user guidelines are not tested.

Storage Temperature	-65 °C to +150 °C
Ambient Temperature with Power Applied	-55 °C to +125 °C
Supply Voltage on V _{CC} Relative to GND [2]	-0.5 V to +4.6 V
DC Voltage Applied to Outputs in High Z State [2]	-0.5 V to V _{CC} + 0.5 V

DC Input Voltage [2]	-0.5 V to V _{CC} + 0.5 V
Current into Outputs (LOW)	20 mA
Static Discharge Voltage (MIL-STD-883, Method 3015)	> 2001 V
Latch Up Current	> 200 mA

Operating Range

Range	Ambient Temperature (T _A)	V _{CC}
Automotive-A	-40 °C to +85 °C	3.3 V ± 10%
Automotive-E	-40 °C to +125 °C	

Electrical Characteristics

Over the Operating Range

Parameter	Description	Test Conditions	-10		-12		-20		Unit	
			Min	Max	Min	Max	Min	Max		
V _{OH}	Output HIGH Voltage	V _{CC} = Min, I _{OH} = -4.0 mA	2.4	-	2.4	-	2.4	-	V	
V _{OL}	Output LOW Voltage	V _{CC} = Min, I _{OL} = 8.0 mA	-	0.4	-	0.4	-	0.4	V	
V _{IH}	Input HIGH Voltage		2.0	V _{CC} + 0.3	2.0	V _{CC} + 0.3	2.0	V _{CC} + 0.3	V	
V _{IL} [2]	Input LOW Voltage		-0.3	0.8	-0.3	0.8	-0.3	0.8	V	
I _{IX}	Input Leakage Current	GND ≤ V _I ≤ V _{CC}	Auto-A	-1	+1	-	-	-1	+1	μA
			Auto-E	-20	+20	-20	+20	-20	+20	
I _{OZ}	Output Leakage Current	GND ≤ V _{OUT} ≤ V _{CC} , Output disabled	Auto-A	-1	+1	-	-	-1	+1	μA
			Auto-E	-20	+20	-20	+20	-20	+20	
I _{CC}	V _{CC} Operating Supply Current	V _{CC} = Max, f = f _{MAX} = 1/t _{RC}	Auto-A	-	100	-	-	-	85	mA
			Auto-E	-	130	-	120	-	90	
I _{SB1}	Automatic CE Power Down Current – TTL Inputs	Max V _{CC} , $\overline{CE} \geq V_{IH}$, V _{IN} ≥ V _{IH} , or V _{IN} ≤ V _{IL} , f = f _{MAX}	Auto-A	-	40	-	-	-	40	mA
			Auto-E	-	45	-	45	-	45	
I _{SB2}	Automatic CE Power Down Current – CMOS Inputs	Max V _{CC} , CE ≥ V _{CC} - 0.3 V, V _{IN} ≥ V _{CC} - 0.3 V, or V _{IN} ≤ 0.3 V, f = 0	Auto-A	-	10	-	-	-	10	mA
			Auto-E	-	15	-	15	-	15	

Note

2. V_{IL(min)} = -2.0 V and V_{IH(max)} = V_{CC} + 0.5 V for pulse durations of less than 20 ns.

Capacitance

Parameter ^[3]	Description	Test Conditions	Max	Unit
C _{IN}	Input Capacitance	T _A = 25 °C, f = 1 MHz, V _{CC} = 3.3 V	8	pF
C _{OUT}	Output Capacitance		8	pF

Thermal Resistance

Parameter ^[3]	Description	Test Conditions	44-pin SOJ	44-pin TSOP II	48-ball FBGA	Unit
Θ _{JA}	Thermal resistance (junction to ambient)	Test conditions follow standard test methods and procedures for measuring thermal impedance, per EIA/JESD51	25.99	42.96	38.15	°C/W
Θ _{JC}	Thermal resistance (junction to case)		18.8	10.75	9.15	°C/W

AC Test Loads and Waveforms

Figure 3. AC Test Loads and Waveforms ^[4]

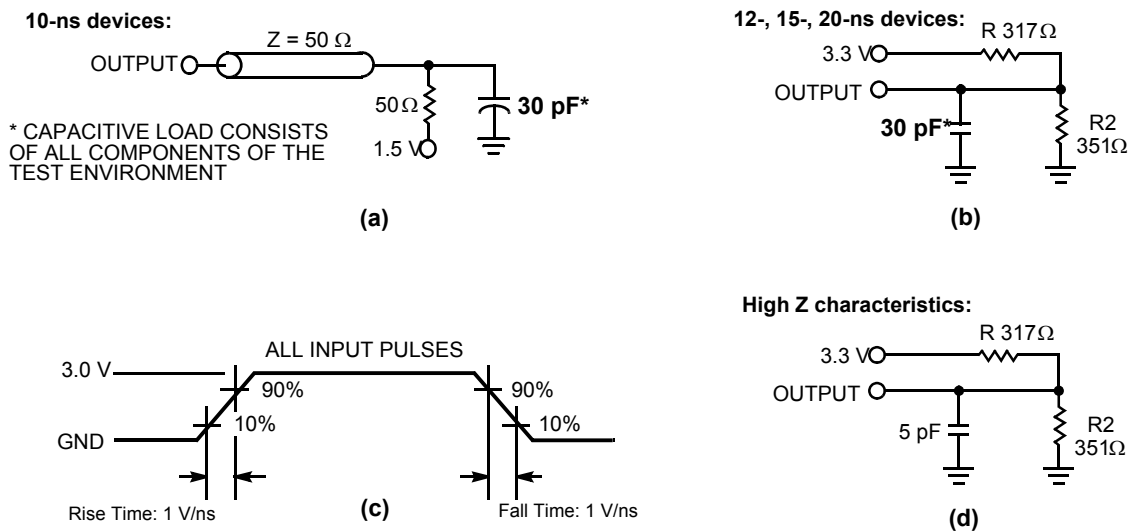

Notes

- 3. Tested initially and after any design or process changes that may affect these parameters.
- 4. AC characteristics (except High Z) for 10 ns parts are tested using the load conditions shown in Figure 3 (a). All other speeds are tested using the Thevenin load shown in Figure 3 (b). High Z characteristics are tested for all speeds using the test load shown in Figure 3 (d).

Switching Characteristics

Over the Operating Range

Parameter ^[5]	Description	-10		-12		-20		Unit	
		Min	Max	Min	Max	Min	Max		
Read Cycle									
$t_{power}^{[6]}$	V_{CC} (Typical) to the First Access	100	–	100	–	100	–	μ s	
t_{RC}	Read Cycle Time	10	–	12	–	20	–	ns	
t_{AA}	Address to Data Valid	–	10	–	12	–	20	ns	
t_{OHA}	Data Hold from Address Change	3	–	3	–	3	–	ns	
t_{ACE}	\overline{CE} LOW to Data Valid	–	10	–	12	–	20	ns	
t_{DOE}	\overline{OE} LOW to Data Valid	Auto-A	–	5	–	6	–	8	ns
		Auto-E	–	6	–	7	–	8	
t_{LZOE}	\overline{OE} LOW to Low Z ^[7]	0	–	0	–	0	–	ns	
t_{HZOE}	\overline{OE} HIGH to High Z ^[7, 8]	–	5	–	6	–	8	ns	
t_{LZCE}	\overline{CE} LOW to Low Z ^[7]	3	–	3	–	3	–	ns	
t_{HZCE}	\overline{CE} HIGH to High Z ^[7, 8]	–	5	–	6	–	8	ns	
t_{PU}	\overline{CE} LOW to Power Up	0	–	0	–	0	–	ns	
t_{PD}	\overline{CE} HIGH to Power Down	–	10	–	12	–	20	ns	
t_{DBE}	Byte Enable to Data Valid	Auto-A	–	5	–	6	–	8	ns
		Auto-E	–	6	–	7	–	8	
t_{LZBE}	Byte Enable to Low Z	0	–	0	–	0	–	ns	
t_{HZBE}	Byte Disable to High Z	–	6	–	6	–	8	ns	
Write Cycle ^[9, 10]									
t_{WC}	Write Cycle Time	10	–	12	–	20	–	ns	
t_{SCE}	\overline{CE} LOW to Write End	7	–	8	–	10	–	ns	
t_{AW}	Address Setup to Write End	7	–	8	–	10	–	ns	
t_{HA}	Address Hold from Write End	0	–	0	–	0	–	ns	
t_{SA}	Address Setup to Write Start	0	–	0	–	0	–	ns	
t_{PWE}	\overline{WE} Pulse Width	7	–	8	–	10	–	ns	
t_{SD}	Data Setup to Write End	5	–	6	–	8	–	ns	
t_{HD}	Data Hold from Write End	0	–	0	–	0	–	ns	
t_{LZWE}	\overline{WE} HIGH to Low Z ^[7]	3	–	3	–	3	–	ns	
t_{HZWE}	\overline{WE} LOW to High Z ^[7, 8]	–	5	–	6	–	8	ns	
t_{BW}	Byte Enable to End of Write	7	–	8	–	10	–	ns	

Notes

- Test conditions assume signal transition time of 3 ns or less, timing reference levels of 1.5 V, and input pulse levels of 0 to 3.0 V.
- t_{POWER} gives the minimum amount of time that the power supply is at typical V_{CC} values until the first memory access is performed.
- At any temperature and voltage condition, t_{HZCE} is less than t_{LZCE} , t_{HZBE} is less than t_{LZBE} , t_{HZOE} is less than t_{LZOE} , and t_{HZWE} is less than t_{LZWE} for any device.
- t_{HZOE} , t_{HZCE} , t_{HZBE} , and t_{HZWE} are specified with a load capacitance of 5 pF as in part (d) of [Figure 3 on page 6](#). Transition is measured ± 500 mV from steady state voltage.
- The internal write time of the memory is defined by the overlap of \overline{CE} LOW, \overline{WE} LOW, and $\overline{BHE}/\overline{BLE}$ LOW. \overline{CE} , \overline{WE} , and $\overline{BHE}/\overline{BLE}$ must be LOW to initiate a write. The transition of these signals terminate the write. The input data setup and hold timing is referenced to the leading edge of the signal that terminates the write.
- The minimum Write cycle time for Write Cycle No. 3 (\overline{WE} controlled, \overline{OE} LOW) is the sum of t_{HZWE} and t_{SD} .

Switching Waveforms

Figure 4. Read Cycle No. 1 (Address Transition Controlled) [11, 12]

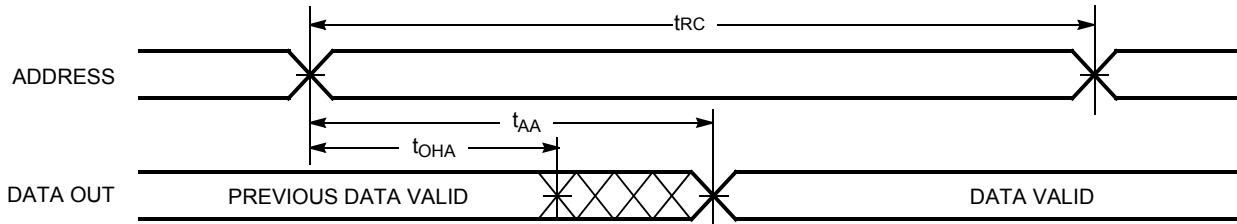
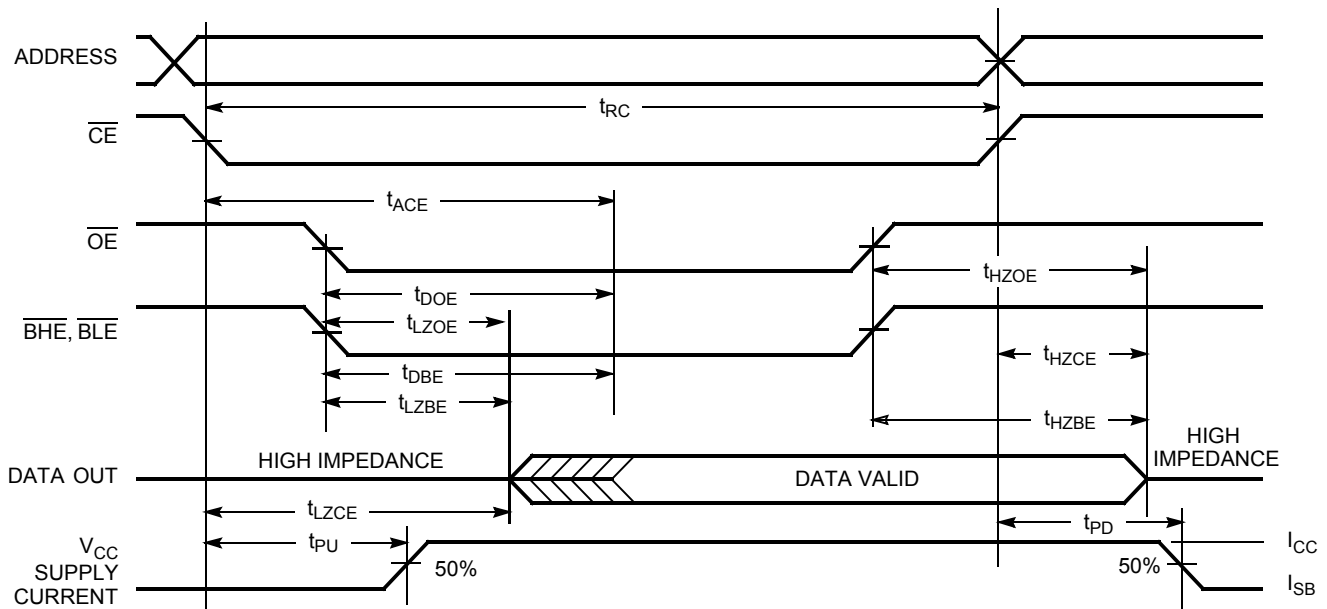

Figure 5. Read Cycle No. 2 (\overline{OE} Controlled) [12, 13]



Notes

- 11. Device is continuously selected. \overline{OE} , \overline{CE} , \overline{BHE} , and/or $\overline{BLE} = V_{IL}$.
- 12. \overline{WE} is HIGH for read cycle.
- 13. Address valid prior to or coincident with \overline{CE} transition LOW.

Switching Waveforms (continued)

Figure 6. Write Cycle No. 1 ($\overline{\text{CE}}$ Controlled) [14, 15]

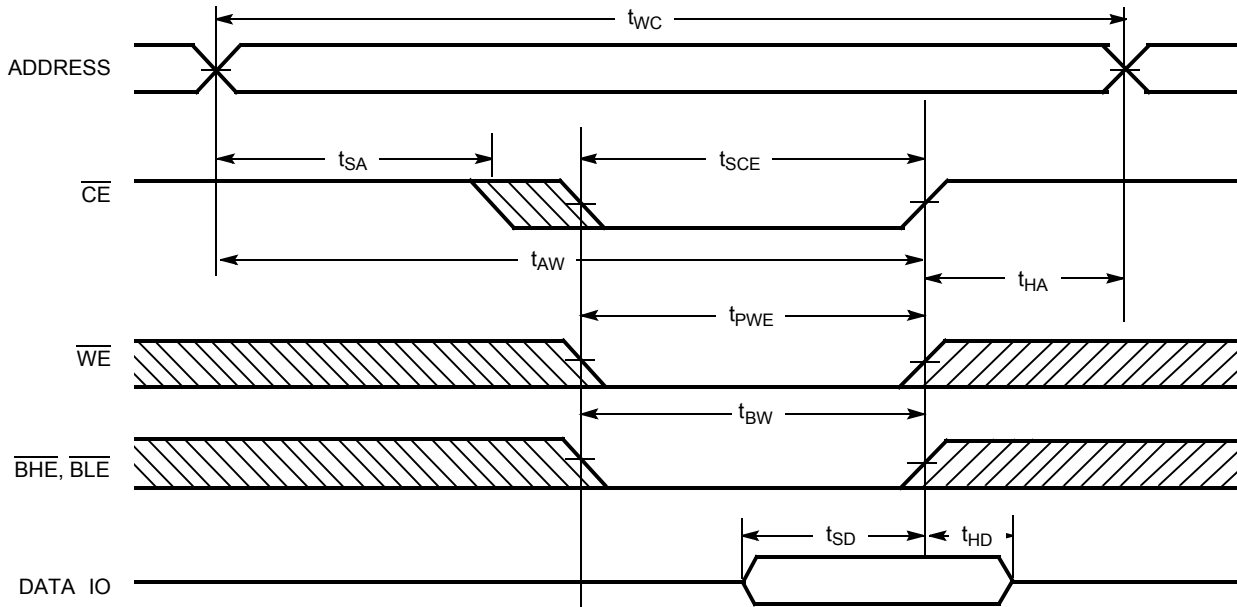
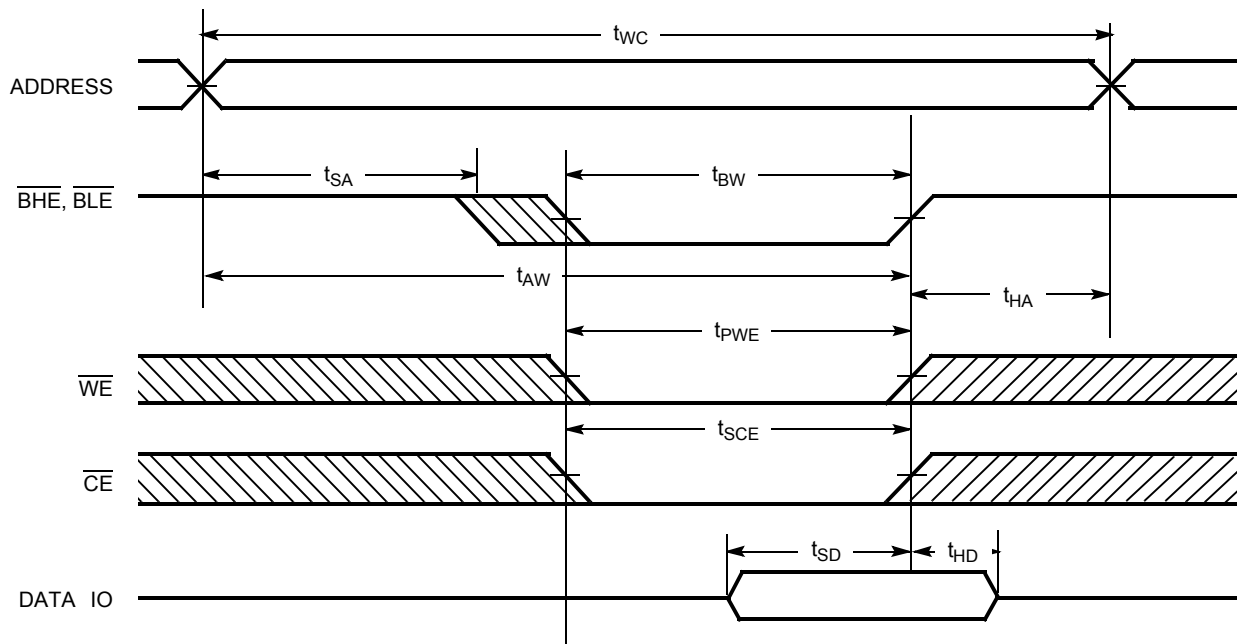

Figure 7. Write Cycle No. 2 ($\overline{\text{BLE}}$ or $\overline{\text{BHE}}$ Controlled)



Notes

- 14. Data IO is high impedance if $\overline{\text{OE}}$, $\overline{\text{BHE}}$, and/or $\overline{\text{BLE}} = V_{IH}$.
- 15. If $\overline{\text{CE}}$ goes HIGH simultaneously with $\overline{\text{WE}}$ going HIGH, the output remains in a high impedance state.

Switching Waveforms (continued)

Figure 8. Write Cycle No. 3 (\overline{WE} Controlled, \overline{OE} LOW)

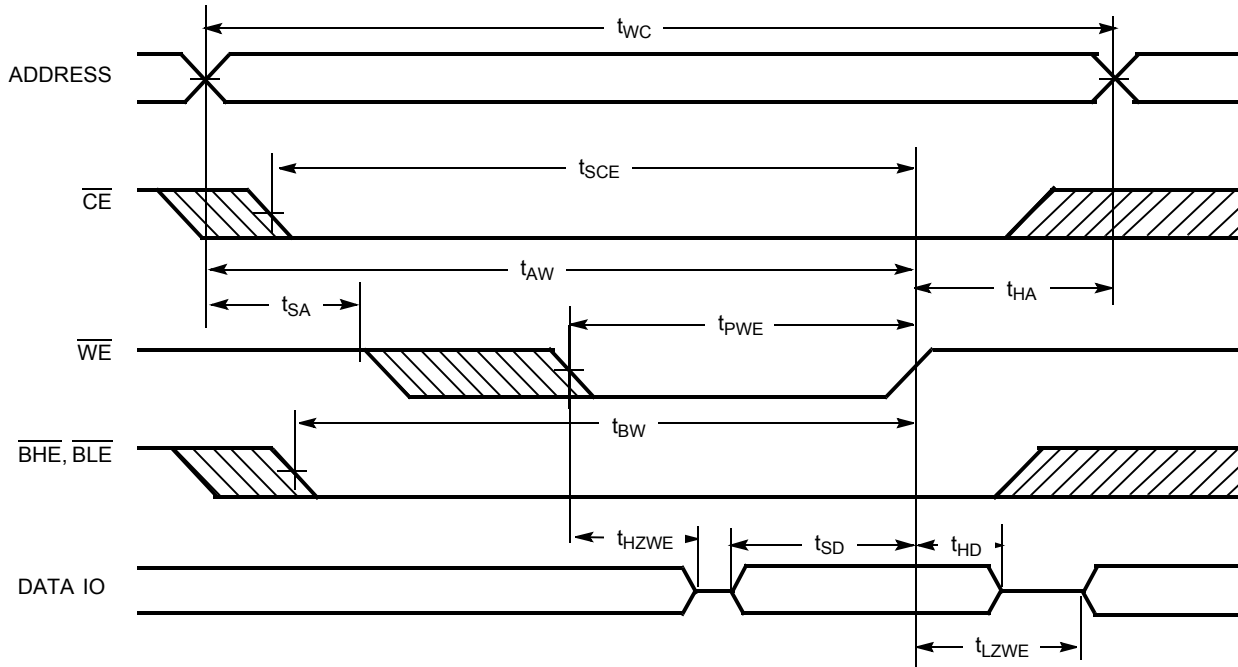

Truth Table

\overline{CE}	\overline{OE}	\overline{WE}	\overline{BLE}	\overline{BHE}	I/O ₀ -I/O ₇	I/O ₈ -I/O ₁₅	Mode	Power
H	X	X	X	X	High Z	High Z	Power Down	Standby (I _{SB})
L	L	H	L	L	Data Out	Data Out	Read – All Bits	Active (I _{CC})
			L	H	Data Out	High Z	Read – Lower Bits Only	Active (I _{CC})
			H	L	High Z	Data Out	Read – Upper Bits Only	Active (I _{CC})
L	X	L	L	L	Data In	Data In	Write – All Bits	Active (I _{CC})
			L	H	Data In	High Z	Write – Lower Bits Only	Active (I _{CC})
			H	L	High Z	Data In	Write – Upper Bits Only	Active (I _{CC})
L	H	H	X	X	High Z	High Z	Selected, Outputs Disabled	Active (I _{CC})
L	X	X	H	H	High Z	High Z	Selected, Outputs Disabled	Active (I _{CC})

Ordering Information

Cypress offers other versions of this type of product in many different configurations and features. The below table contains only the list of parts that are currently available. For a complete listing of all options, visit the Cypress website at www.cypress.com and refer to the product summary page at <http://www.cypress.com/products> or contact your local sales representative.

Cypress maintains a worldwide network of offices, solution centers, manufacturer's representatives and distributors. To find the office closest to you, visit us at <http://www.cypress.com/go/datasheet/offices>.

Speed (ns)	Ordering Code	Package Diagram	Package Type	Operating Range
10	CY7C1041CV33-10BAXA	51-85106	48-ball FBGA (Pb-free)	Automotive-A
	CY7C1041CV33-10ZSXA	51-85087	44-pin TSOP II (Pb-free)	
	CY7C1041CV33-10BAXE	51-85106	48-ball FBGA (Pb-free)	Automotive-E
12	CY7C1041CV33-12BAXE	51-85106	48-ball FBGA (Pb-free)	Automotive-E
	CY7C1041CV33-12ZSXE	51-85087	44-pin TSOP II (Pb-free)	
20	CY7C1041CV33-20ZSXA	51-85087	44-pin TSOP II (Pb-free)	Automotive-A
	CY7C1041CV33-20VXE		44-pin (400-mil) Molded SOJ (Pb-free)	Automotive-E
	CY7C1041CV33-20ZSXE		44-pin TSOP II (Pb-free)	

Please contact your local Cypress sales representative for availability of these parts

Ordering Code Definitions

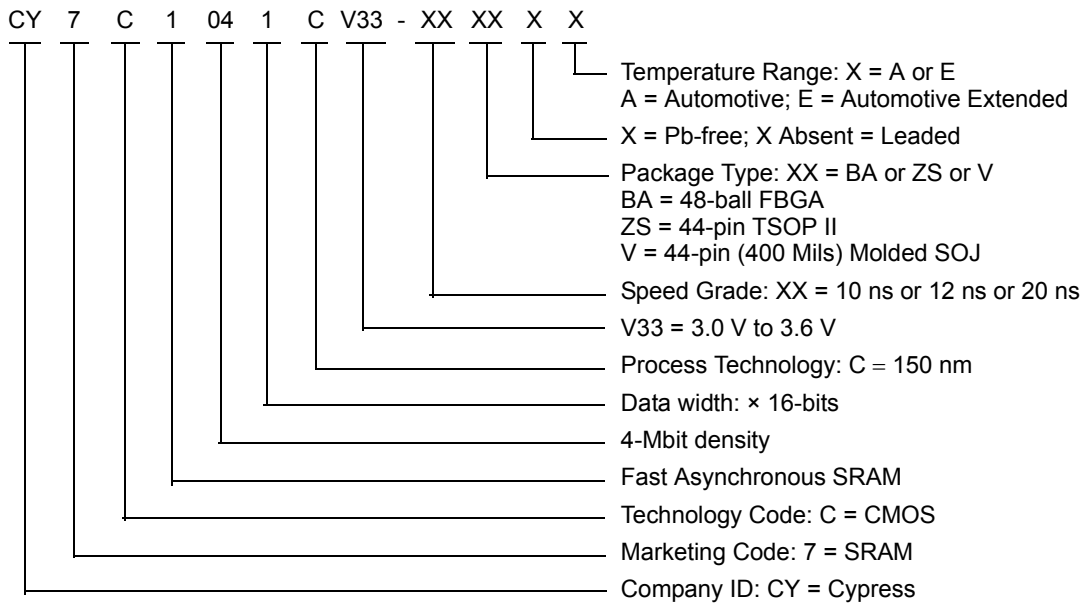

Package Diagrams

Figure 9. 44-pin SOJ 400 Mils V44.4 Package Outline, 51-85082

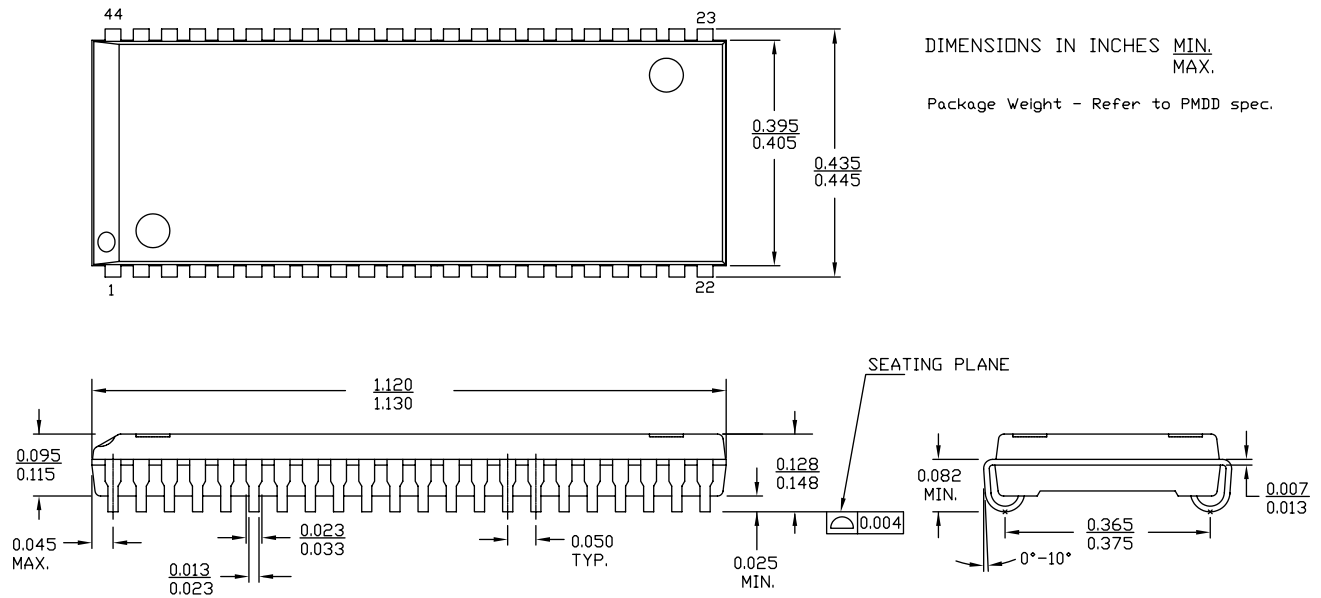

51-85082 *E

Package Diagrams (continued)

Figure 10. 44-pin TSOP Z44-II Package Outline, 51-85087

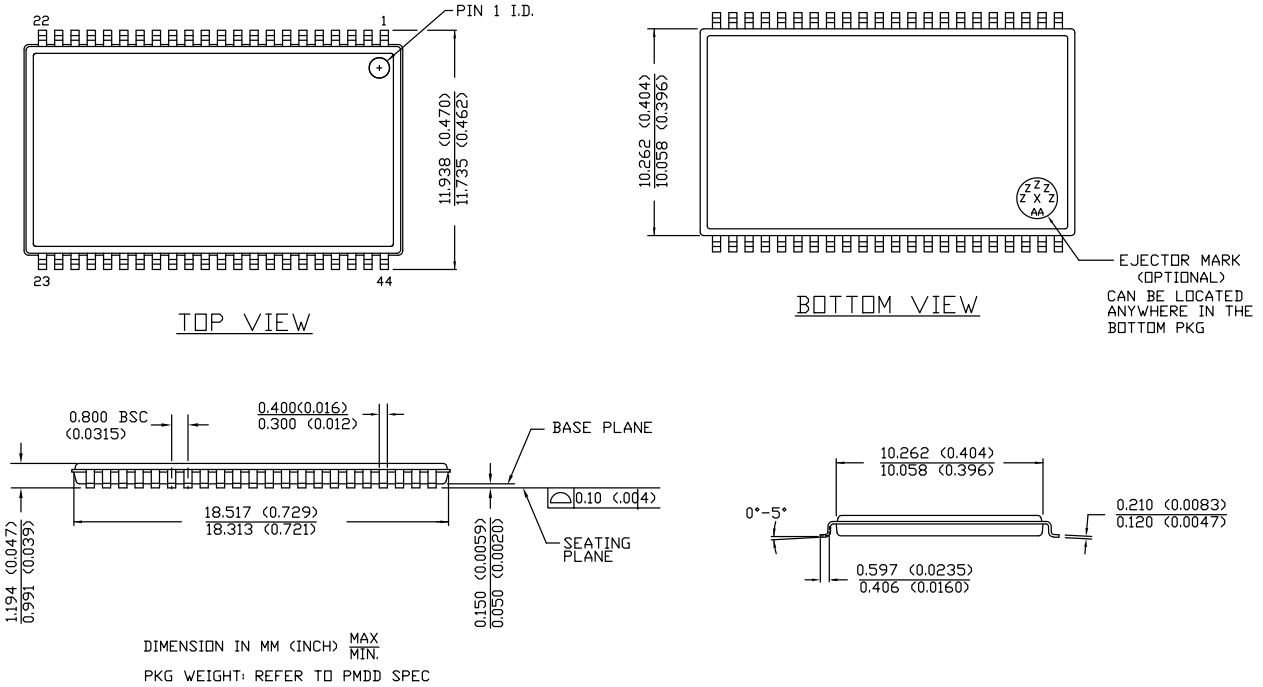

51-85087 *E

Package Diagrams (continued)

Figure 11. 48-ball FBGA (7.0 × 8.5 × 1.2 mm) BA48A Package Outline, 51-85106

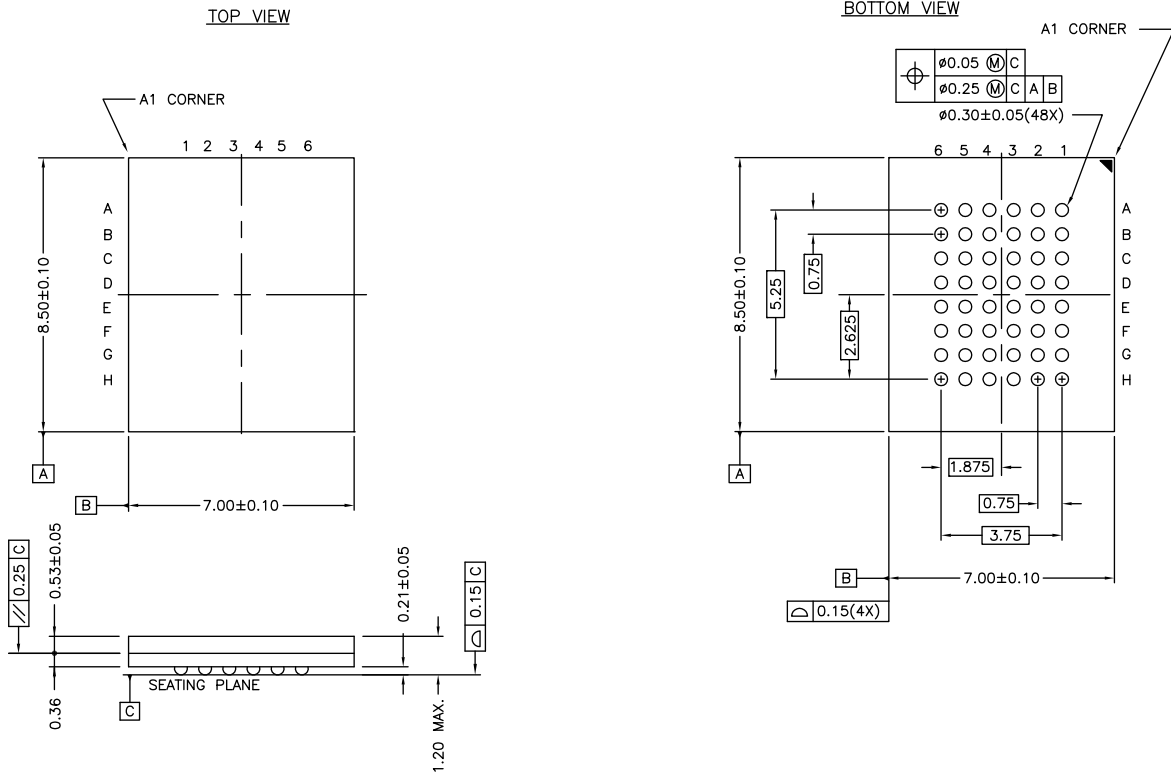

51-85106 *G

Acronyms

Acronym	Description
\overline{CE}	Chip Enable
CMOS	Complementary Metal Oxide Semiconductor
FBGA	Fine-Pitch Ball Grid Array
I/O	Input/Output
\overline{OE}	Output Enable
SOJ	Small Outline J-lead
SRAM	Static Random Access Memory
TSOP	Thin Small Outline Package
TTL	Transistor-Transistor Logic
\overline{WE}	Write Enable

Document Conventions

Units of Measure

Symbol	Unit of Measure
°C	degree Celsius
MHz	megahertz
μA	microampere
μs	microsecond
mA	milliampere
mm	millimeter
ms	millisecond
mW	milliwatt
ns	nanosecond
Ω	ohm
%	percent
pF	picofarad
V	volt
W	watt

Document History Page

Document Title: CY7C1041CV33 Automotive, 4-Mbit (256 K × 16) Static RAM Document Number: 001-67307				
Rev.	ECN No.	Issue Date	Orig. of Change	Description of Change
**	3187164	03/03/2011	PRAS	Separation of the automotive datasheet from CY7C1041CV33 spec no. 38-05134 Rev. *K. Further rev of 38-05134 would include only industrial / commercial parts.
*A	3265070	05/24/2011	PRAS	Updated Functional Description (Removed “For best practice recommendations, refer to the Cypress application note AN1064, SRAM System Guidelines.”).
*B	3507652	01/24/2012	TAVA	Updated Features . Updated Selection Guide . Updated Electrical Characteristics . Updated Switching Characteristics . Updated Ordering Information . Updated Package Diagrams .
*C	4318563	03/24/2014	VINI	Updated Package Diagrams : spec 51-85082 – Changed revision from *D to *E. spec 51-85087 – Changed revision from *D to *E. Updated in new template. Completing Sunset Review.

Sales, Solutions, and Legal Information

Worldwide Sales and Design Support

Cypress maintains a worldwide network of offices, solution centers, manufacturer's representatives, and distributors. To find the office closest to you, visit us at [Cypress Locations](#).

Products

Automotive	cypress.com/go/automotive
Clocks & Buffers	cypress.com/go/clocks
Interface	cypress.com/go/interface
Lighting & Power Control	cypress.com/go/powerpsoc cypress.com/go/plc
Memory	cypress.com/go/memory
PSoC	cypress.com/go/psoc
Touch Sensing	cypress.com/go/touch
USB Controllers	cypress.com/go/USB
Wireless/RF	cypress.com/go/wireless

PSoC[®] Solutions

psoc.cypress.com/solutions
[PSoC 1](#) | [PSoC 3](#) | [PSoC 4](#) | [PSoC 5LP](#)

Cypress Developer Community

[Community](#) | [Forums](#) | [Blogs](#) | [Video](#) | [Training](#)

Technical Support

cypress.com/go/support

© Cypress Semiconductor Corporation, 2011-2014. The information contained herein is subject to change without notice. Cypress Semiconductor Corporation assumes no responsibility for the use of any circuitry other than circuitry embodied in a Cypress product. Nor does it convey or imply any license under patent or other rights. Cypress products are not warranted nor intended to be used for medical, life support, life saving, critical control or safety applications, unless pursuant to an express written agreement with Cypress. Furthermore, Cypress does not authorize its products for use as critical components in life-support systems where a malfunction or failure may reasonably be expected to result in significant injury to the user. The inclusion of Cypress products in life-support systems application implies that the manufacturer assumes all risk of such use and in doing so indemnifies Cypress against all charges.

Any Source Code (software and/or firmware) is owned by Cypress Semiconductor Corporation (Cypress) and is protected by and subject to worldwide patent protection (United States and foreign), United States copyright laws and international treaty provisions. Cypress hereby grants to licensee a personal, non-exclusive, non-transferable license to copy, use, modify, create derivative works of, and compile the Cypress Source Code and derivative works for the sole purpose of creating custom software and or firmware in support of licensee product to be used only in conjunction with a Cypress integrated circuit as specified in the applicable agreement. Any reproduction, modification, translation, compilation, or representation of this Source Code except as specified above is prohibited without the express written permission of Cypress.

Disclaimer: CYPRESS MAKES NO WARRANTY OF ANY KIND, EXPRESS OR IMPLIED, WITH REGARD TO THIS MATERIAL, INCLUDING, BUT NOT LIMITED TO, THE IMPLIED WARRANTIES OF MERCHANTABILITY AND FITNESS FOR A PARTICULAR PURPOSE. Cypress reserves the right to make changes without further notice to the materials described herein. Cypress does not assume any liability arising out of the application or use of any product or circuit described herein. Cypress does not authorize its products for use as critical components in life-support systems where a malfunction or failure may reasonably be expected to result in significant injury to the user. The inclusion of Cypress' product in a life-support systems application implies that the manufacturer assumes all risk of such use and in doing so indemnifies Cypress against all charges.

Use may be limited by and subject to the applicable Cypress software license agreement.

Looking for pricing, stock, or lifecycle information?

Click below to explore more details on WIN SOURCE:

- ⊖ [View CY7C1041CV33-12BAXE on WIN SOURCE](#)
- ⊖ [Cypress Semiconductor Corp Information](#)

Optimize Your Supply Chain with WIN SOURCE Solutions

- ✓ Global Sourcing Solution
- ✓ Obsolete Management
- ✓ Cost Control Management
- ✓ Shortage Management
- ✓ Alternative Solution
- ✓ Excess Inventory Management