



**THE DATASHEET OF
MC100EP210SMNR4G**



MC100EP210S

2.5V 1:5 Dual Differential LVDS Compatible Clock Driver

Description

The MC100EP210S is a low skew 1-to-5 dual differential driver, designed with LVDS clock distribution in mind. The LVDS or LVPECL input signals are differential and the signal is fanned out to five identical differential LVDS outputs.

The EP210S specifically guarantees low output-to-output skew. Optimal design, layout, and processing minimize skew within a device and from device to device.

Two internal 50 Ω resistors are provided across the inputs. For LVDS inputs, VTA and VTB pins should be unconnected. For LVPECL inputs, VTA and VTB pins should be connected to the V_{TT} ($V_{CC} - 2.0$ V) supply.

Designers can take advantage of the EP210S performance to distribute low skew LVDS clocks across the backplane or the board.

Features

- 20 ps Typical Output-to-Output Skew
- 85 ps Typical Device-to-Device Skew
- 550 ps Typical Propagation Delay
- The 100 Series Contains Temperature Compensation
- Maximum Frequency > 1 GHz Typical
- Operating Range: $V_{CC} = 2.375$ V to 2.625 V with $V_{EE} = 0$ V
- Internal 50 Ω Input Termination Resistors
- LVDS Input/Output Compatible
- These are Pb-Free Devices



ON Semiconductor®

<http://onsemi.com>

MARKING DIAGRAM*



LQFP-32
FA SUFFIX
CASE 873A

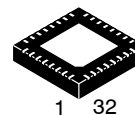
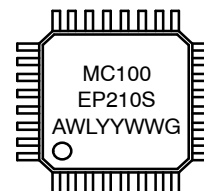

QFN32
MN SUFFIX
CASE 488AM

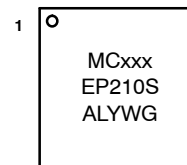

xxx = 10 or 100
A = Assembly Location
WL, L = Wafer Lot
YY, Y = Year
WW, W = Work Week
G = Pb-Free Package

*For additional marking information, refer to Application Note AND8002/D.

ORDERING INFORMATION

See detailed ordering and shipping information in the package dimensions section on page 6 of this data sheet.

MC100EP210S

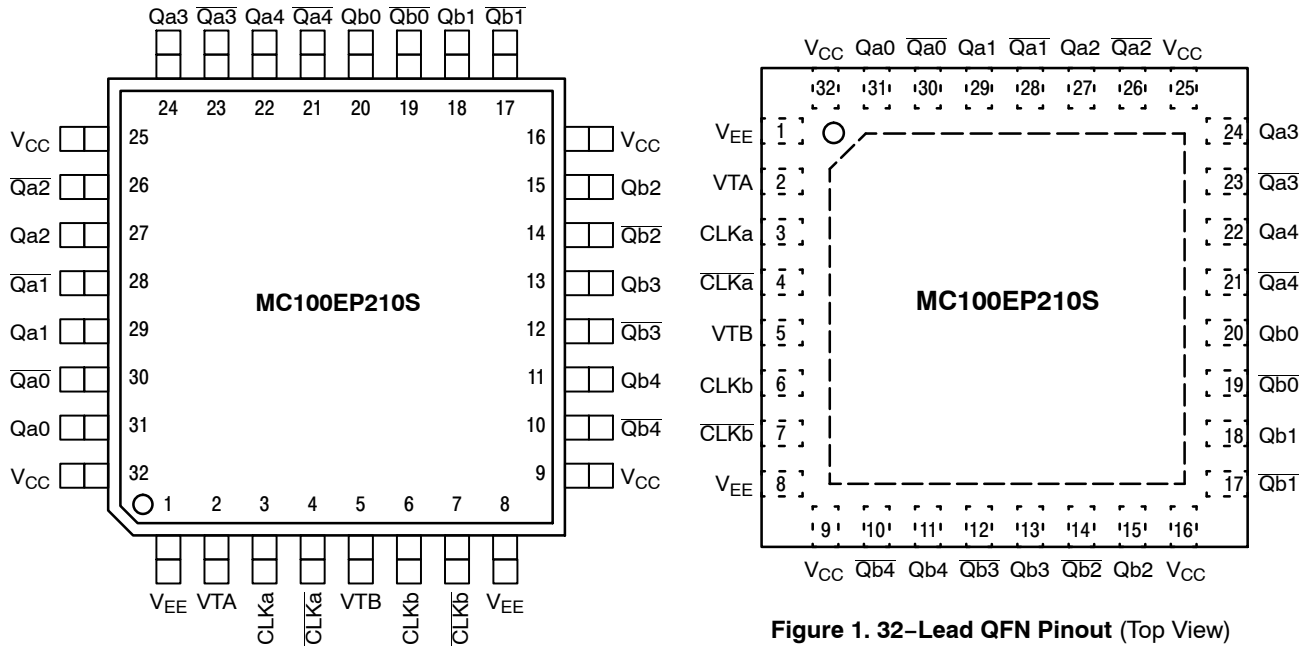

Figure 1. 32-Lead QFN Pinout (Top View)

Warning: All V_{CC} and V_{EE} pins must be externally connected to Power Supply to guarantee proper operation.

Figure 1. 32-Lead LQFP Pinout (Top View)

Table 1. PIN DESCRIPTION

PIN	FUNCTION
CLKn, \overline{CLKn}	LVDS, LVPECL CLK Inputs*
Qn0:4, $\overline{Qn0:4}$	LVDS Outputs
VTA	50 Ω Termination Resistors
VTB	50 Ω Termination Resistors
V_{CC}	Positive Supply
V_{EE}	Ground
EP for QFN-32, only	The Exposed Pad (EP) on the QFN-32 package bottom is thermally connected to the die for improved heat transfer out of package. The exposed pad must be attached to a heat-sinking conduit. The pad is electrically connected to V_{EE} .

*Under open or floating conditions with input pins converging to a common termination bias voltage the device is susceptible to auto oscillation.

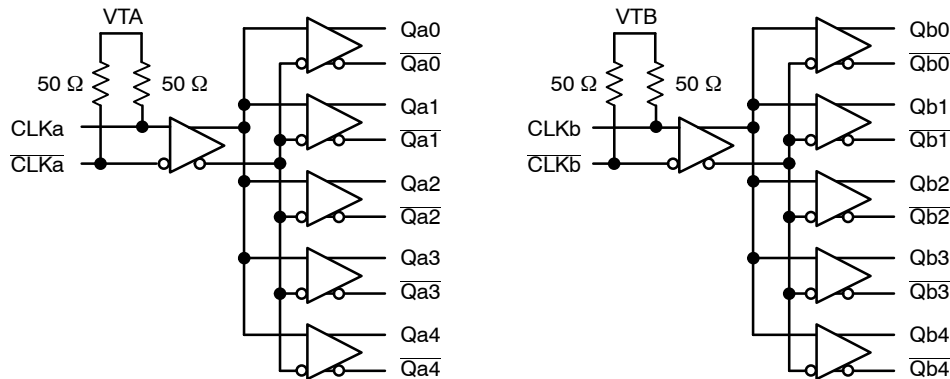

Figure 2. Logic Diagram

MC100EP210S

Table 2. ATTRIBUTES

Characteristics	Value	
ESD Protection	Human Body Model Machine Model Charged Device Model	> 2 kV > 100 V > 2 kV
Moisture Sensitivity, Indefinite Time Out of Drypack (Note 1)	Pb Pkg	Pb-Free Pkg
	LQFP-32 QFN-32	Level 2 Level 1
Flammability Rating	Oxygen Index: 28 to 34	UL 94 V-0 @ 0.125 in
Transistor Count	461 Devices	
Meets or exceeds JEDEC Spec EIA/JESD78 IC Latchup Test		

1. For additional information, refer to Application Note AND8003/D.

Table 3. MAXIMUM RATINGS

Symbol	Parameter	Condition 1	Condition 2	Rating	Unit
V _{CC}	Power Supply	V _{EE} = 0 V		6	V
V _{EE}	Power Supply (GND)	V _{CC} = 2.5 V		-6	V
V _I	LVDS, LVPECL Input Voltage	V _{EE} = 0 V	V _I ≤ V _{CC}	6	V
I _{out}	Output Current	Continuous Surge		50 100	mA mA
T _A	Operating Temperature Range			-40 to +85	°C
T _{stg}	Storage Temperature Range			-65 to +150	°C
θ _{JA}	Thermal Resistance (Junction-to-Ambient)	0 lfpm 500 lfpm	32 LQFP 32 LQFP	80 55	°C/W °C/W
θ _{JC}	Thermal Resistance (Junction-to-Case)	Standard Board	32 LQFP	12 to 17	°C/W
θ _{JA}	Thermal Resistance (Junction-to-Ambient)	0 lfpm 500 lfpm	QFN-32 QFN-32	31 27	°C/W °C/W
θ _{JC}	Thermal Resistance (Junction-to-Case)	2S2P	QFN-32	12	°C/W
T _{sol}	Wave Solder	Pb Pb-Free		265 265	°C

Stresses exceeding Maximum Ratings may damage the device. Maximum Ratings are stress ratings only. Functional operation above the Recommended Operating Conditions is not implied. Extended exposure to stresses above the Recommended Operating Conditions may affect device reliability.

MC100EP210S

Table 4. DC CHARACTERISTICS $V_{CC} = 2.5\text{ V}$, $V_{EE} = 0\text{ V}$ (Note 2)

Symbol	Characteristic	-40°C			25°C			85°C			Unit
		Min	Typ	Max	Min	Typ	Max	Min	Typ	Max	
I_{EE}	Power Supply Current		150	200		150	200		150	200	mA
V_{OH}	Output HIGH Voltage (Note 3)	1250	1400	1550	1250	1400	1550	1250	1400	1550	mV
V_{OL}	Output LOW Voltage (Note 3)	800	950	1100	800	950	1100	800	950	1100	mV
V_{IHCMR}	Input HIGH Voltage Common Mode Range (Differential Configuration) (Note 4)	1.2		2.5	1.2		2.5	1.2		2.5	V
R_T	Internal Termination Resistor	43		57	43	50	57	43		57	Ω
I_{IH}	Input HIGH Current			150			150			150	μA
I_{IL}	Input LOW Current	CLK CLK	-150 -150	150 150	-150 -150		150 150	-150 -150		150 150	μA

NOTE: Device will meet the specifications after thermal equilibrium has been established when mounted in a test socket or printed circuit board with maintained transverse airflow greater than 500 lfm. Electrical parameters are guaranteed only over the declared operating temperature range. Functional operation of the device exceeding these conditions is not implied. Device specification limit values are applied individually under normal operating conditions and not valid simultaneously.

2. Input and output parameters vary 1:1 with V_{CC} .

3. All loading with 100 Ω across LVDS differential outputs.

4. V_{IHCMR} min varies 1:1 with V_{EE} , V_{IHCMR} max varies 1:1 with V_{CC} . The V_{IHCMR} range is referenced to the most positive side of the differential input signal.

Table 5. AC CHARACTERISTICS $V_{CC} = 2.375$ to 2.625 V , $V_{EE} = 0\text{ V}$ (Note 5)

Symbol	Characteristic	-40°C			25°C			85°C			Unit
		Min	Typ	Max	Min	Typ	Max	Min	Typ	Max	
$f_{\text{maxLVDS/LVPECL}}$	Maximum Frequency (See Figure 2. $F_{\text{max/JITTER}}$)		> 1			> 1			> 1		GHz
t_{PLH} t_{PHL}	Propagation Delay	425	525	625	450	550	650	475	575	675	ps
t_{skew}	Within-Device Skew (Note 6) Device-to-Device Skew (Note 7) Duty Cycle Skew (Note 8)		20 85 80	25 160 100		20 85 80	25 160 100		20 85 80	35 160 100	ps
t_{JITTER}	RMS Random Clock Jitter		0.2	< 1		0.2	< 1		0.2	< 1	ps
V_{PP}	Minimum Input Swing	150	800	1200	150	800	1200	150	800	1200	mV
t_r/t_f	Output Rise/Fall Time (20%–80%)	50	130	200	75	150	225	80	160	230	ps

NOTE: Device will meet the specifications after thermal equilibrium has been established when mounted in a test socket or printed circuit board with maintained transverse airflow greater than 500 lfm. Electrical parameters are guaranteed only over the declared operating temperature range. Functional operation of the device exceeding these conditions is not implied. Device specification limit values are applied individually under normal operating conditions and not valid simultaneously.

5. Measured with 400 mV source, 50% duty cycle clock source. All loading with 100 Ω across differential outputs.

6. Skew is measured between outputs under identical transitions of similar paths through a device.

7. Device-to-Device skew for identical transitions at identical V_{CC} levels.

8. Duty cycle skew guaranteed only for differential operation measured from the cross point of the input to the cross point of the output.

MC100EP210S

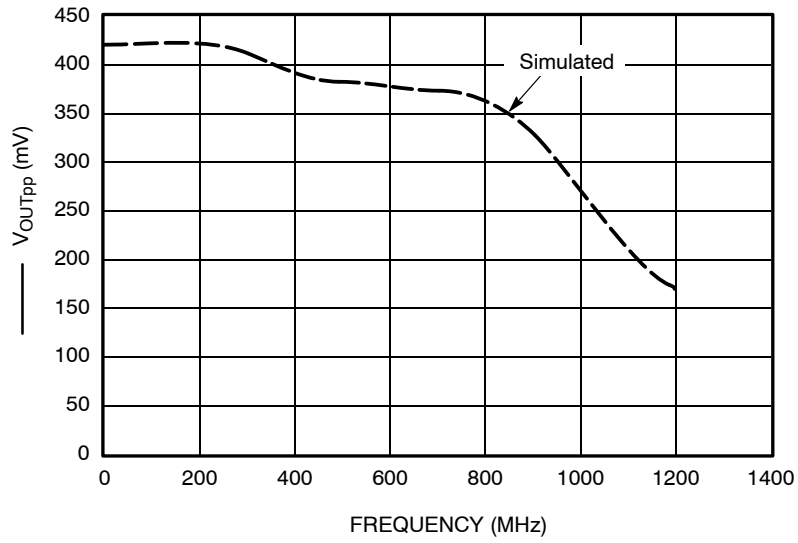

Figure 2. F_{max}

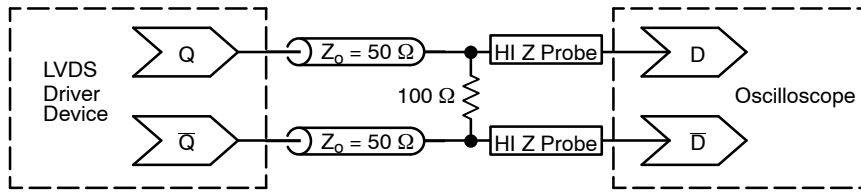

Figure 3. Typical Termination for Output Driver and Device Evaluation

MC100EP210S

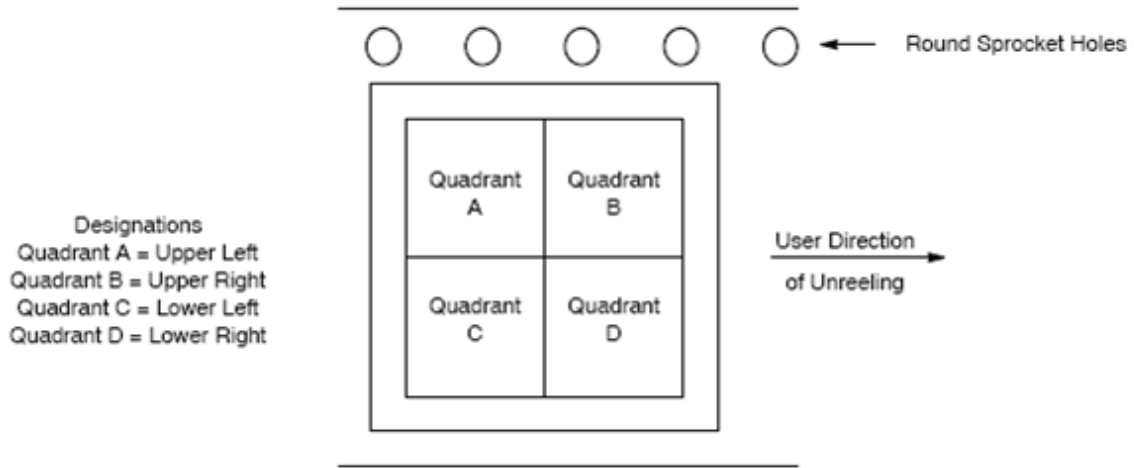

Figure 4. Tape and Reel Pin 1 Quadrant Orientation

ORDERING INFORMATION

Device	Package	Shipping [†]
MC100EP210SFAG	LQFP-32 (Pb-Free)	250 Units / Tray
MC100EP210SFAR2G	LQFP-32 (Pb-Free)	2000 / Tape & Reel (Pin 1 Orientation in Quadrant B, Figure 4)
MC100EP210SFATWG	LQFP-32 (Pb-Free)	2000 / Tape & Reel (Pin 1 Orientation in Quadrant A, Figure 4)
MC100EP210SMNG	QFN-32 (Pb-Free)	72 Units / Tray
MC100EP210SMNR4G	QFN-32 (Pb-Free)	1000 / Tape & Reel

[†]For information on tape and reel specifications, including part orientation and tape sizes, please refer to our Tape and Reel Packaging Specifications Brochure, BRD8011/D.

MC100EP210S

PACKAGE DIMENSIONS

32 LEAD LQFP
CASE 873A-02
ISSUE C

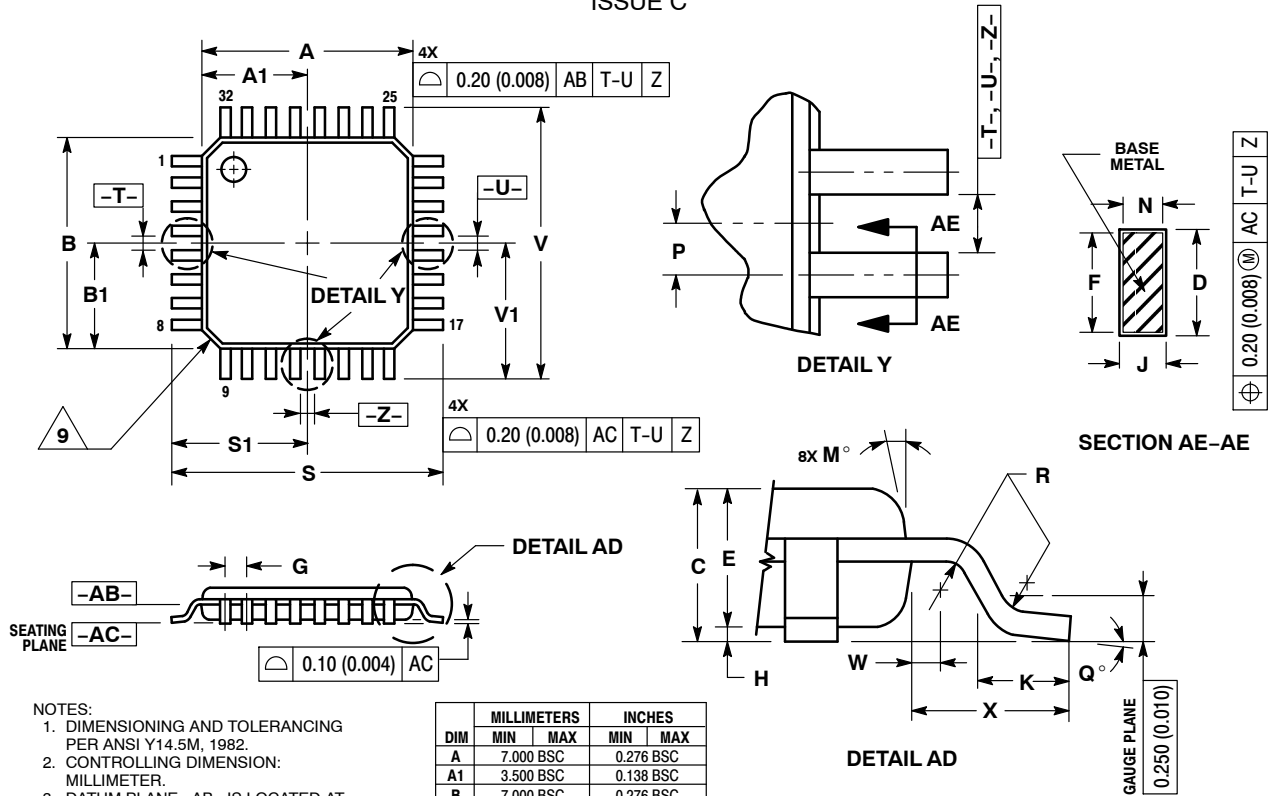

NOTES:

1. DIMENSIONING AND TOLERANCING PER ANSI Y14.5M, 1982.
2. CONTROLLING DIMENSION: MILLIMETER.
3. DATUM PLANE -AB- IS LOCATED AT BOTTOM OF LEAD AND IS COINCIDENT WITH THE LEAD WHERE THE LEAD EXITS THE PLASTIC BODY AT THE BOTTOM OF THE PARTING LINE.
4. DATUMS -T-, -U-, AND -Z- TO BE DETERMINED AT DATUM PLANE -AB-.
5. DIMENSIONS S AND V TO BE DETERMINED AT SEATING PLANE -AC-.
6. DIMENSIONS A AND B DO NOT INCLUDE MOLD PROTRUSION. ALLOWABLE PROTRUSION IS 0.250 (0.010) PER SIDE. DIMENSIONS A AND B DO INCLUDE MOLD MISMATCH AND ARE DETERMINED AT DATUM PLANE -AB-.
7. DIMENSION D DOES NOT INCLUDE DAMBAR PROTRUSION. DAMBAR PROTRUSION SHALL NOT CAUSE THE D DIMENSION TO EXCEED 0.520 (0.020).
8. MINIMUM SOLDER PLATE THICKNESS SHALL BE 0.0076 (0.0003).
9. EXACT SHAPE OF EACH CORNER MAY VARY FROM DEPICTION.

DIM	MILLIMETERS		INCHES	
	MIN	MAX	MIN	MAX
A	7.000 BSC		0.276 BSC	
A1	3.500 BSC		0.138 BSC	
B	7.000 BSC		0.276 BSC	
B1	3.500 BSC		0.138 BSC	
C	1.400	1.600	0.055	0.063
D	0.300	0.450	0.012	0.018
E	1.350	1.450	0.053	0.057
F	0.300	0.400	0.012	0.016
G	0.800 BSC		0.031 BSC	
H	0.050	0.150	0.002	0.006
J	0.090	0.200	0.004	0.008
K	0.450	0.750	0.018	0.030
M	12° REF		12° REF	
N	0.090	0.160	0.004	0.006
P	0.400 BSC		0.016 BSC	
Q	1°	5°	1°	5°
R	0.150	0.250	0.006	0.010
S	9.000 BSC		0.354 BSC	
S1	4.500 BSC		0.177 BSC	
V	9.000 BSC		0.354 BSC	
V1	4.500 BSC		0.177 BSC	
W	0.200 REF		0.008 REF	
X	1.000 REF		0.039 REF	

MC100EP210S

PACKAGE DIMENSIONS

QFN32 5*5*1 0.5 P
CASE 488AM-01
ISSUE O

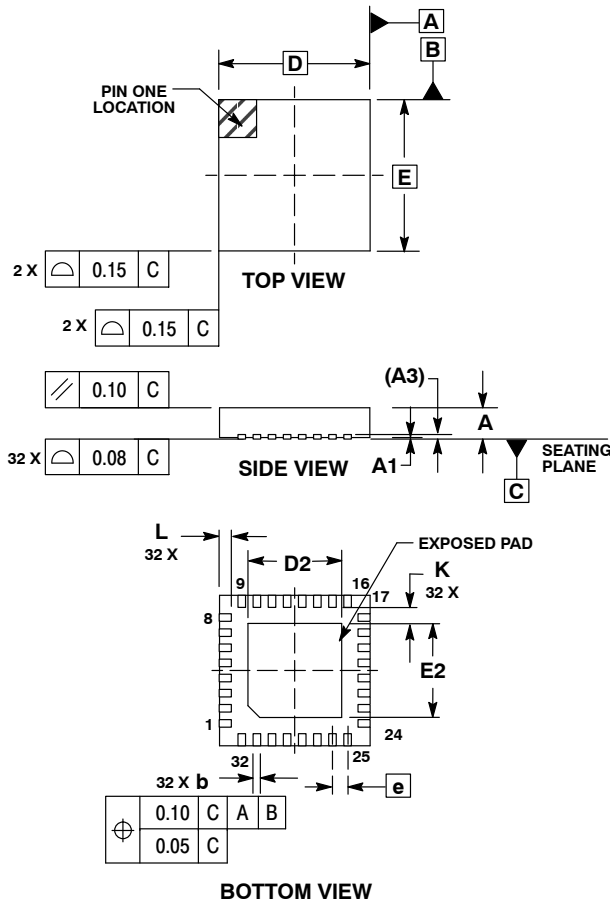

NOTES:

1. DIMENSIONS AND TOLERANCING PER ASME Y14.5M, 1994.
2. CONTROLLING DIMENSION: MILLIMETERS.
3. DIMENSION b APPLIES TO PLATED TERMINAL AND IS MEASURED BETWEEN 0.25 AND 0.30 MM TERMINAL
4. COPLANARITY APPLIES TO THE EXPOSED PAD AS WELL AS THE TERMINALS.

MILLIMETERS			
DIM	MIN	NOM	MAX
A	0.800	0.900	1.000
A1	0.000	0.025	0.050
A3	0.200 REF		
b	0.180	0.250	0.300
D	5.00 BSC		
D2	2.950	3.100	3.250
E	5.00 BSC		
E2	2.950	3.100	3.250
e	0.500 BSC		
K	0.200	---	---
L	0.300	0.400	0.500

SOLDERING FOOTPRINT*

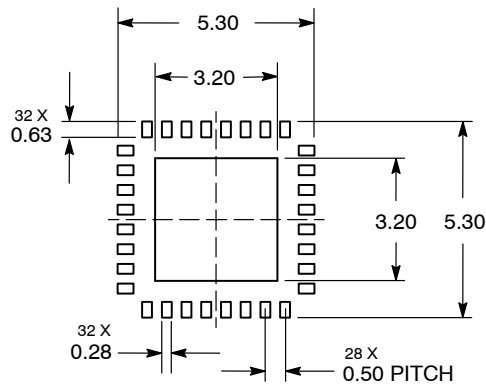

*For additional information on our Pb-Free strategy and soldering details, please download the ON Semiconductor Soldering and Mounting Techniques Reference Manual, SOLDERRM/D.

ON Semiconductor and are registered trademarks of Semiconductor Components Industries, LLC (SCILLC). SCILLC reserves the right to make changes without further notice to any products herein. SCILLC makes no warranty, representation or guarantee regarding the suitability of its products for any particular purpose, nor does SCILLC assume any liability arising out of the application or use of any product or circuit, and specifically disclaims any and all liability, including without limitation special, consequential or incidental damages. "Typical" parameters which may be provided in SCILLC data sheets and/or specifications can and do vary in different applications and actual performance may vary over time. All operating parameters, including "Typicals" must be validated for each customer application by customer's technical experts. SCILLC does not convey any license under its patent rights nor the rights of others. SCILLC products are not designed, intended, or authorized for use as components in systems intended for surgical implant into the body, or other applications intended to support or sustain life, or for any other application in which the failure of the SCILLC product could create a situation where personal injury or death may occur. Should Buyer purchase or use SCILLC products for any such unintended or unauthorized application, Buyer shall indemnify and hold SCILLC and its officers, employees, subsidiaries, affiliates, and distributors harmless against all claims, costs, damages, and expenses, and reasonable attorney fees arising out of, directly or indirectly, any claim of personal injury or death associated with such unintended or unauthorized use, even if such claim alleges that SCILLC was negligent regarding the design or manufacture of the part. SCILLC is an Equal Opportunity/Affirmative Action Employer. This literature is subject to all applicable copyright laws and is not for resale in any manner.

PUBLICATION ORDERING INFORMATION



LITERATURE FULFILLMENT:
Literature Distribution Center for ON Semiconductor
P.O. Box 5163, Denver, Colorado 80217 USA
Phone: 303-675-2175 or 800-344-3860 Toll Free USA/Canada
Fax: 303-675-2176 or 800-344-3867 Toll Free USA/Canada
Email: orderlit@onsemi.com

N. American Technical Support: 800-282-9855 Toll Free USA/Canada
Europe, Middle East and Africa Technical Support:
Phone: 421 33 790 2910
Japan Customer Focus Center
Phone: 81-3-5773-3850

ON Semiconductor Website: www.onsemi.com
Order Literature: <http://www.onsemi.com/orderlit>
For additional information, please contact your local Sales Representative

Looking for pricing, stock, or lifecycle information?

Click below to explore more details on WIN SOURCE:

-  [View MC100EP210SMNR4G on WIN SOURCE](#)
-  [ON Semiconductor Information](#)

Optimize Your Supply Chain with WIN SOURCE Solutions

-  Global Sourcing Solution
-  Obsolete Management
-  Cost Control Management
-  Shortage Management
-  Alternative Solution
-  Excess Inventory Management