



Is Now Part of



ON Semiconductor®

To learn more about ON Semiconductor, please visit our website at
www.onsemi.com

Please note: As part of the Fairchild Semiconductor integration, some of the Fairchild orderable part numbers will need to change in order to meet ON Semiconductor's system requirements. Since the ON Semiconductor product management systems do not have the ability to manage part nomenclature that utilizes an underscore (_), the underscore (_) in the Fairchild part numbers will be changed to a dash (-). This document may contain device numbers with an underscore (_). Please check the ON Semiconductor website to verify the updated device numbers. The most current and up-to-date ordering information can be found at www.onsemi.com. Please email any questions regarding the system integration to Fairchild_questions@onsemi.com.

ON Semiconductor and the ON Semiconductor logo are trademarks of Semiconductor Components Industries, LLC dba ON Semiconductor or its subsidiaries in the United States and/or other countries. ON Semiconductor owns the rights to a number of patents, trademarks, copyrights, trade secrets, and other intellectual property. A listing of ON Semiconductor's product/patent coverage may be accessed at www.onsemi.com/site/pdf/Patent-Marking.pdf. ON Semiconductor reserves the right to make changes without further notice to any products herein. ON Semiconductor makes no warranty, representation or guarantee regarding the suitability of its products for any particular purpose, nor does ON Semiconductor assume any liability arising out of the application or use of any product or circuit, and specifically disclaims any and all liability, including without limitation special, consequential or incidental damages. Buyer is responsible for its products and applications using ON Semiconductor products, including compliance with all laws, regulations and safety requirements or standards, regardless of any support or applications information provided by ON Semiconductor. "Typical" parameters which may be provided in ON Semiconductor data sheets and/or specifications can and do vary in different applications and actual performance may vary over time. All operating parameters, including "Typicals" must be validated for each customer application by customer's technical experts. ON Semiconductor does not convey any license under its patent rights nor the rights of others. ON Semiconductor products are not designed, intended, or authorized for use as a critical component in life support systems or any FDA Class 3 medical devices or medical devices with a same or similar classification in a foreign jurisdiction or any devices intended for implantation in the human body. Should Buyer purchase or use ON Semiconductor products for any such unintended or unauthorized application, Buyer shall indemnify and hold ON Semiconductor and its officers, employees, subsidiaries, affiliates, and distributors harmless against all claims, costs, damages, and expenses, and reasonable attorney fees arising out of, directly or indirectly, any claim of personal injury or death associated with such unintended or unauthorized use, even if such claim alleges that ON Semiconductor was negligent regarding the design or manufacture of the part. ON Semiconductor is an Equal Opportunity/Affirmative Action Employer. This literature is subject to all applicable copyright laws and is not for resale in any manner.

FSQ0365, FSQ0265, FSQ0165, FSQ321 Green Mode Fairchild Power Switch (FPS™) for Valley Switching Converter – *Low EMI and High Efficiency*

Features

- Optimized for Valley Switching Converter (VSC)
- Low EMI through Variable Frequency Control and Inherent Frequency Modulation
- High Efficiency through Minimum Voltage Switching
- Narrow Frequency Variation Range Over Wide Load and Input Voltage Variation
- Advanced Burst-Mode Operation for Low Standby Power Consumption
- Pulse-by-Pulse Current Limit
- Protection Functions: Overload Protection (OLP), Over-Voltage Protection (OVP), Abnormal Over-Current Protection (AOCP), Internal Thermal Shutdown (TSD)
- Under-Voltage Lockout (UVLO) with Hysteresis
- Internal Startup Circuit
- Internal High-Voltage SenseFET: 650V
- Built-in Soft-Start: 15ms

Applications

- Power Supplies for DVP Player, DVD Recorder, Set-Top Box
- Adapter
- Auxiliary Power Supply for PC, LCD TV, and PDP TV

Description

A Valley Switching Converter generally shows lower EMI and higher power conversion efficiency than a conventional hard-switched converter with a fixed switching frequency. The FSQ-series is an integrated Pulse-Width Modulation (PWM) controller and SenseFET specifically designed for valley switching operation with minimal external components. The PWM controller includes an integrated fixed-frequency oscillator, under-voltage lockout, Leading-Edge Blanking (LEB), optimized gate driver, internal soft-start, temperature-compensated precise current sources for loop compensation, and self-protection circuitry.

Compared with discrete MOSFET and PWM controller solutions, the FSQ-series reduces total cost, component count, size and weight; while simultaneously increasing efficiency, productivity, and system reliability. This device provides a basic platform for cost-effective designs of valley switching fly-back converters.

Related Application Notes

- [AN-4137 - Design Guidelines for Offline Flyback Converters Using Fairchild Power Switch \(FPS™\)](#)
- [AN-4141 - Troubleshooting and Design Tips for Fairchild Power Switch \(FPS™\) Flyback Applications](#)
- [AN-4147 - Design Guidelines for RCD Snubber of Flyback Converters](#)
- [AN-4150 - Design Guidelines for Flyback Converters Using FSQ-series Fairchild Power Switch \(FPS™\)](#)
- [AN-4134 - Design Guidelines for Off-line Forward Converters Using Fairchild Power Switch \(FPS™\)](#)

Ordering Information

Part Number	Package	Operating Temperature	Current Limit	R _{DS(ON)} (Max.)	Maximum Output Table ⁽¹⁾				Replaces Devices
					230V _{AC} ±15% ⁽²⁾		85-265V _{AC}		
					Adapter ⁽³⁾	Open Frame ⁽⁴⁾	Adapter ⁽³⁾	Open Frame ⁽⁴⁾	
FSQ321	8-DIP	-40 to +85°C	0.6A	19Ω	8W	12W	7W	10W	FSDL321 FSDM311
FSQ321L	8-LSOP								
FSQ321LX	8-LSOP (Tape & Reel)								
FSQ0165RN	8-DIP	-40 to +85°C	0.9A	10Ω	10W	15W	9W	13W	FSDL0165RN
FSQ0165RL	8-LSOP								
FSQ0165RLX	8-LSOP (Tape & Reel)								
FSQ0265RN	8-DIP	-40 to +85°C	1.2A	6Ω	14W	20W	11W	16W	FSDM0265RN FSDM0265RNB
FSQ0265RL	8-LSOP								
FSQ0365RN	8-DIP	-40 to +85°C	1.5A	4.5Ω	17.5W	25W	13W	19W	FSDM0365RN FSDM0365RNB
FSQ0365RL	8-LSOP								

Notes:

1. The junction temperature can limit the maximum output power.
2. 230V_{AC} or 100/115V_{AC} with voltage doubler. The maximum power with CCM operation
3. Typical continuous power in a non-ventilated, enclosed adapter measured at 50°C ambient temperature.
4. Maximum practical continuous power in an open-frame design at 50°C ambient temperature.

Pin Assignments

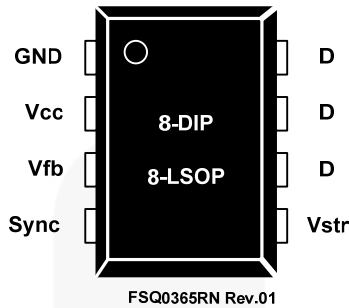

Figure 3. Pin Configuration (Top View)

Pin Definitions

Pin#	Name	Description
1	GND	SenseFET source terminal on primary side and internal control ground.
2	V _{CC}	Positive supply voltage input. Although connected to an auxiliary transformer winding, current is supplied from pin 5 (V _{str}) via an internal switch during startup (see Figure 2). It is not until V _{CC} reaches the UVLO upper threshold (12V) that the internal startup switch opens and device power is supplied via the auxiliary transformer winding.
3	V _{fb}	The feedback voltage pin is the non-inverting input to the PWM comparator. It has a 0.9mA current source connected internally while a capacitor and opto-coupler are typically connected externally. There is a time delay while charging external capacitor C _{fb} from 3V to 6V using an internal 5μA current source. This delay prevents false triggering under transient conditions, but still allows the protection mechanism to operate under true overload conditions.
4	Sync	This pin is internally connected to the sync-detect comparator for valley switching. Typically the voltage of the auxiliary winding is used as Sync input voltage and external resistors and capacitor are needed to make delay to match valley point. The threshold of the internal sync comparator is 0.7V/0.2V.
5	V _{str}	This pin is connected to the rectified AC line voltage source. At startup, the internal switch supplies internal bias and charges an external storage capacitor placed between the V _{CC} pin and ground. Once the V _{CC} reaches 12V, the internal switch is opened.
6, 7, 8	Drain	The drain pins are designed to connect directly to the primary lead of the transformer and are capable of switching a maximum of 650V. Minimizing the length of the trace connecting these pins to the transformer decreases leakage inductance.

Absolute Maximum Ratings

Stresses exceeding the absolute maximum ratings may damage the device. The device may not function or be operable above the recommended operating conditions and stressing the parts to these levels is not recommended. In addition, extended exposure to stresses above the recommended operating conditions may affect device reliability. The absolute maximum ratings are stress ratings only. $T_A=25^{\circ}\text{C}$, unless otherwise specified.

Symbol	Parameter	Min.	Max.	Unit
V_{STR}	Vstr Pin Voltage	500		V
V_{DS}	Drain Pin Voltage	650		V
V_{CC}	Supply Voltage		20	V
V_{FB}	Feedback Voltage Range	-0.3	9.0	V
V_{Sync}	Sync Pin Voltage	-0.3	9.0	V
I_{DM}	Drain Current Pulsed ⁽⁶⁾	FSQ0365	12.0	A
		FSQ0265	8.0	
		FSQ0165	4.0	
		FSQ321	1.5	
E_{AS}	Single Pulsed Avalanche Energy ⁽⁷⁾	FSQ0365	230	mJ
		FSQ0265	140	
		FSQ0165	50	
		FSQ321	10	
P_D	Total Power Dissipation		1.5	W
T_J	Recommended Operating Junction Temperature	-40	Internally Limited	$^{\circ}\text{C}$
T_A	Operating Ambient Temperature	-40	+85	$^{\circ}\text{C}$
T_{STG}	Storage Temperature	-55	+150	$^{\circ}\text{C}$
ESD	Human Body Model; JESD22-A114	CLASS 1C		
	Machine Model; JESD22-A115	CLASS B		

Notes:

5. Repetitive rating: Pulse width limited by maximum junction temperature.
6. $L=51\text{mH}$, starting $T_J=25^{\circ}\text{C}$.

Thermal Impedance

Symbol	Parameter	Value	Unit
8-DIP ⁽⁷⁾			
θ_{JA}	Junction-to-Ambient Thermal Resistance ⁽⁸⁾	80	$^{\circ}\text{C}/\text{W}$
θ_{JC}	Junction-to-Case Thermal Resistance ⁽⁹⁾	20	
θ_{JT}	Junction-to-Top Thermal Resistance ⁽¹⁰⁾	35	

Notes:

7. All items are tested with the standards JESD 51-2 and 51-10 (DIP).
8. Free-standing with no heat-sink, under natural convection.
9. Infinite cooling condition - refer to the SEMI G30-88.
10. Measured on the package top surface.

Electrical Characteristics

T_A=25°C unless otherwise specified.

Symbol	Parameter	Condition	Min.	Typ.	Max.	Unit
SenseFET Section						
BV _{DSS}	Drain-Source Breakdown Voltage	V _{CC} =0V, I _D =100μA	650			V
I _{DSS}	Zero-Gate-Voltage Drain Current	V _{DS} =650V			100	μA
R _{DS(ON)}	Drain-Source On-State Resistance ⁽¹¹⁾	T _J =25°C, I _D =0.5A	FSQ0365	3.5	4.5	Ω
			FSQ0265	5.0	6.0	
			FSQ0165	8.0	10.0	
			FSQ321	14.0	19.0	
C _{ISS}	Input Capacitance	V _{GS} =0V, V _{DS} =25V, f=1MHz	FSQ0365	315		pF
			FSQ0265	550		
			FSQ0165	250		
			FSQ321	162		
C _{OSS}	Output Capacitance	V _{GS} =0V, V _{DS} =25V, f=1MHz	FSQ0365	47		pF
			FSQ0265	38		
			FSQ0165	25		
			FSQ321	18		
C _{RSS}	Reverse Transfer Capacitance	V _{GS} =0V, V _{DS} =25V, f=1MHz	FSQ0365	9.0		pF
			FSQ0265	17.0		
			FSQ0165	10.0		
			FSQ321	3.8		
t _{d(on)}	Turn-On Delay	V _{DD} =350V, I _D =25mA	FSQ0365	11.2		ns
			FSQ0265	20.0		
			FSQ0165	12.0		
			FSQ321	9.5		
t _r	Rise Time	V _{DD} =350V, I _D =25mA	FSQ0365	34		ns
			FSQ0265	15		
			FSQ0165	4		
			FSQ321	19		
t _{d(off)}	Turn-Off Delay	V _{DD} =350V, I _D =25mA	FSQ0365	28.2		ns
			FSQ0265	55.0		
			FSQ0165	30.0		
			FSQ321	33.0		
t _f	Fall Time	V _{DD} =350V, I _D =25mA	FSQ0365	32		ns
			FSQ0265	25		
			FSQ0165	10		
			FSQ321	42		
Burst-Mode Section						
V _{BURH}	Burst-Mode Voltage	T _J =25°C, t _{PD} =200ns ⁽¹²⁾	0.45	0.55	0.65	V
V _{BURL}			0.25	0.35	0.45	V
V _{BUR(HYS)}				200		mV

Continued on the following page...

Electrical Characteristics (Continued)

 $T_A=25^\circ\text{C}$ unless otherwise specified.

Symbol	Parameter	Conditions	Min.	Typ.	Max.	Unit
Control Section						
$t_{ON,MAX1}$	Maximum On Time1	All but FSQ321 $T_J=25^\circ\text{C}$	10.5	12.0	13.5	μs
$t_{ON,MAX2}$	Maximum On Time2	FSQ321 $T_J=25^\circ\text{C}$	6.35	7.06	7.77	μs
t_{B1}	Blanking Time1	All but FSQ321	13.2	15.0	16.8	μs
t_{B2}	Blanking Time2	FSQ321	7.5	8.2		μs
t_W	Detection Time Window	$T_J=25^\circ\text{C}$, $V_{sync}=0\text{V}$		3.0		μs
Δf_S	Switching Frequency Variation ⁽¹⁴⁾	$-25^\circ\text{C} < T_J < 85^\circ\text{C}$		± 5	± 10	%
I_{FB}	Feedback Source Current	$V_{FB}=0\text{V}$	700	900	1100	μA
D_{MIN}	Minimum Duty Cycle	$V_{FB}=0\text{V}$			0	%
V_{START}	UVLO Threshold Voltage	After Turn-on	11	12	13	V
V_{STOP}			7	8	9	V
$t_{S/S1}$	Internal Soft-Start Time 1	All but FSQ321 With Free-Running Frequency		15		ms
$t_{S/S2}$	Internal Soft-Start Time 2	FSQ321 With Free-Running Frequency		10		ms
Protection Section						
I_{LIM}	Peak Current Limit	FSQ0365 $T_J=25^\circ\text{C}$, $di/dt=240\text{mA}/\mu\text{s}$	1.32	1.50	1.68	A
		FSQ0265 $T_J=25^\circ\text{C}$, $di/dt=200\text{mA}/\mu\text{s}$	1.06	1.20	1.34	
		FSQ0165 $T_J=25^\circ\text{C}$, $di/dt=175\text{mA}/\mu\text{s}$	0.8	0.9	1.0	
		FSQ321 $T_J=25^\circ\text{C}$, $di/dt=125\text{mA}/\mu\text{s}$	0.53	0.60	0.67	
V_{SD}	Shutdown Feedback Voltage	$V_{CC}=15\text{V}$	5.5	6.0	6.5	V
I_{DELAY}	Shutdown Delay Current	$V_{FB}=5\text{V}$	4.0	5.0	6.0	μA
t_{LEB}	Leading-Edge Blanking Time ⁽¹³⁾			200		ns
V_{OVP}	Over-Voltage Protection	$V_{CC}=15\text{V}$, $V_{FB}=2\text{V}$	5.5	6.0	6.5	V
t_{OVP}	Over-Voltage Protection Blanking Time		2	3	4	μs
T_{SD}	Thermal Shutdown Temperature ⁽¹³⁾		125	140	155	$^\circ\text{C}$
Sync Section						
V_{SH}	Sync Threshold Voltage		0.55	0.70	0.85	V
V_{SL}			0.14	0.20	0.26	V
t_{Sync}	Sync Delay Time ^(13,14)			300		ns
Total Device Section						
I_{OP}	Operating Supply Current (Control Part Only)	$V_{CC}=15\text{V}$	1	3	5	mA
I_{START}	Start Current	$V_{CC}=V_{START} - 0.1\text{V}$ (Before V_{CC} Reaches V_{START})	270	360	450	μA
I_{CH}	Startup Charging Current	$V_{CC}=0\text{V}$, $V_{STR}=\text{Minimum } 40\text{V}$	0.65	0.85	1.00	mA
V_{STR}	Minimum V_{STR} Supply Voltage			26		V

Notes:

11. Pulse test: Pulse-Width=300 μs , duty=2%.
12. Propagation delay in the control IC.
13. Though guaranteed, it is not 100% tested in production.
14. Includes gate turn-on time.

Comparison Between FSDM0x65RNB and FSQ-Series

Function	FSDM0x65RNB	FSQ-Series	Advantages of FSQ-Series
Operation Method	Constant Frequency PWM	Valley Switching Operation	<ul style="list-style-type: none"> ▪ Improved efficiency by valley switching ▪ Reduced EMI noise
EMI Reduction	Frequency Modulation	Valley Switching & Inherent Frequency Modulation	<ul style="list-style-type: none"> ▪ Reduce EMI noise in two ways
Burst-Mode Operation	Fixed Burst Peak	Advanced Burst-Mode	<ul style="list-style-type: none"> ▪ Improved standby power by valley switching also in burst-mode ▪ Because the current peak during burst operation is dependent on V_{FB}, it is easier to solve audible noise
Protection		AOCP	<ul style="list-style-type: none"> ▪ Improved reliability through precise abnormal over-current protection

Typical Performance Characteristics

Characteristic graphs are normalized at $T_A=25^\circ\text{C}$.

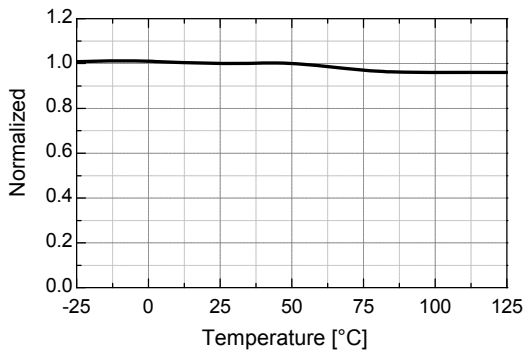

Figure 4. Operating Supply Current (I_{OP}) vs. T_A

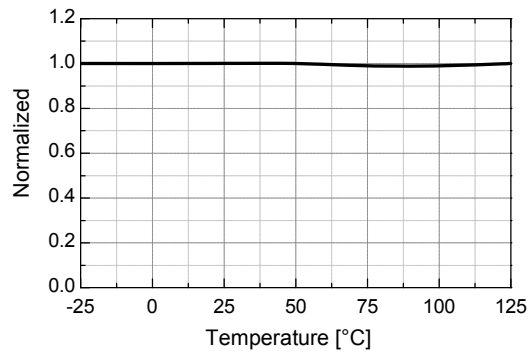

Figure 5. UVLO Start Threshold Voltage (V_{START}) vs. T_A

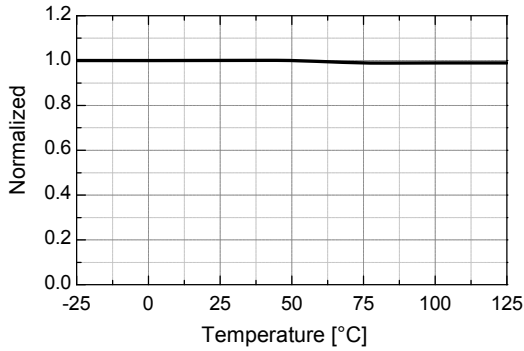

Figure 6. UVLO Stop Threshold Voltage (V_{STOP}) vs. T_A

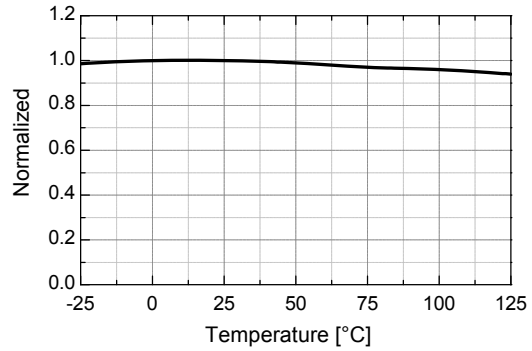

Figure 7. Startup Charging Current (I_{CH}) vs. T_A

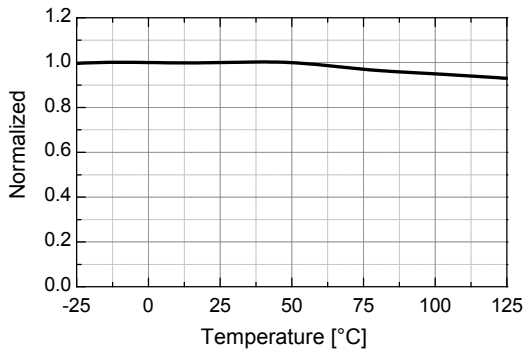

Figure 8. Initial Switching Frequency (f_s) vs. T_A

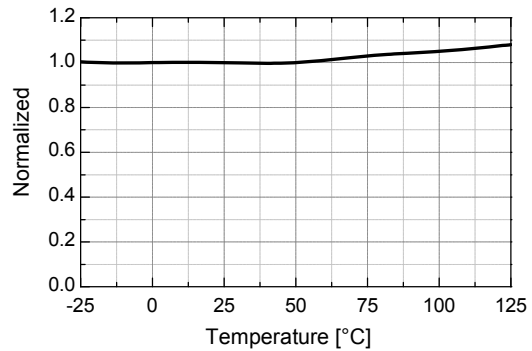

Figure 9. Maximum On Time ($t_{ON,MAX}$) vs. T_A

Typical Performance Characteristics (Continued)

Characteristic graphs are normalized at $T_A=25^\circ\text{C}$.

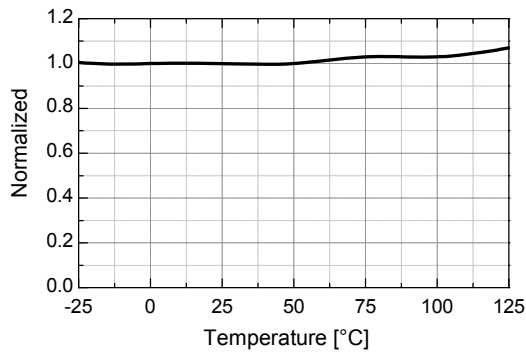

Figure 10. Blanking Time (t_B) vs. T_A

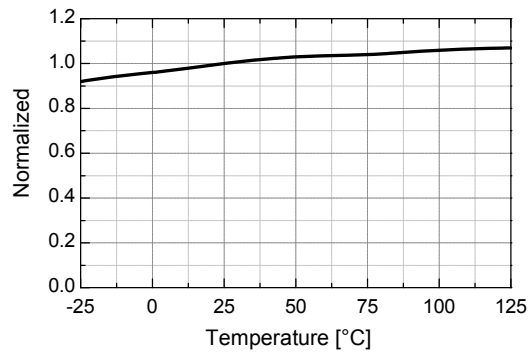

Figure 11. Feedback Source Current (I_{FB}) vs. T_A

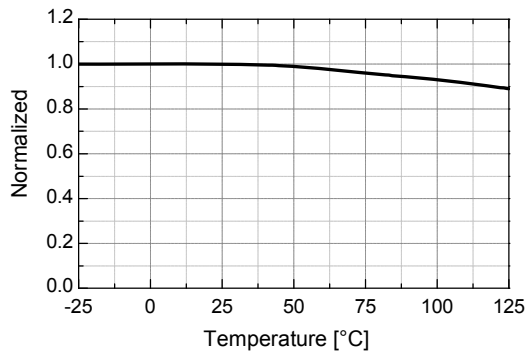

Figure 12. Shutdown Delay Current (I_{DELAY}) vs. T_A

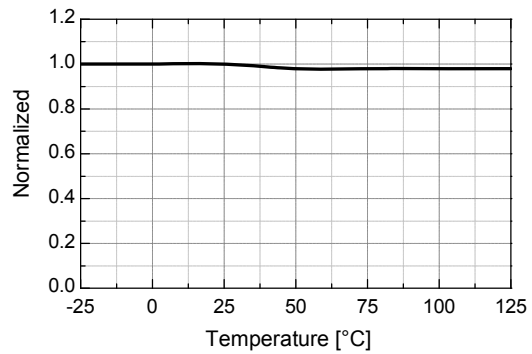

Figure 13. Burst Mode High Threshold Voltage (V_{burh}) vs. T_A

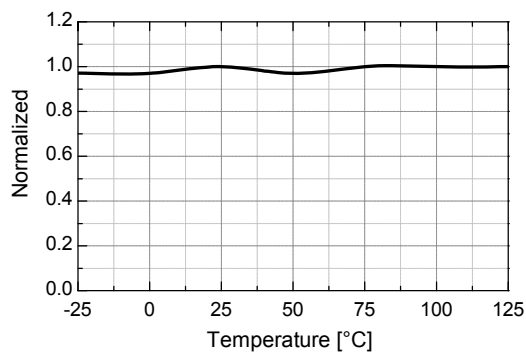

Figure 14. Burst Mode Low Threshold Voltage (V_{burl}) vs. T_A

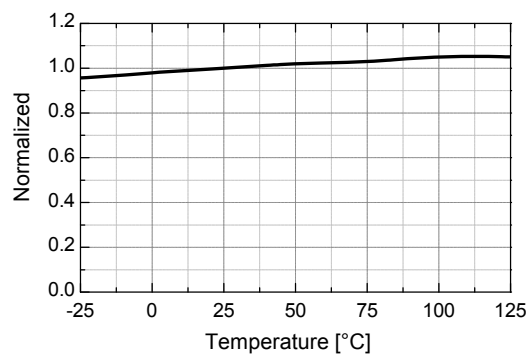

Figure 15. Peak Current Limit (I_{LIM}) vs. T_A

Typical Performance Characteristics (Continued)

Characteristic graphs are normalized at $T_A=25^\circ\text{C}$.

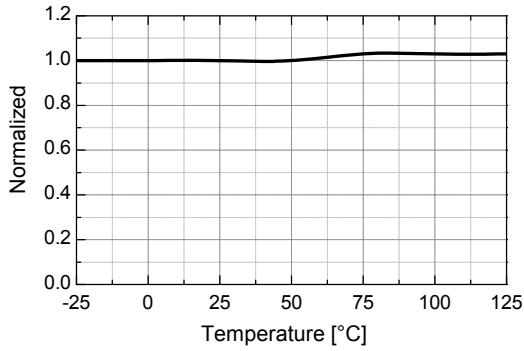

Figure 16. Sync High Threshold (V_{SH}) vs. T_A

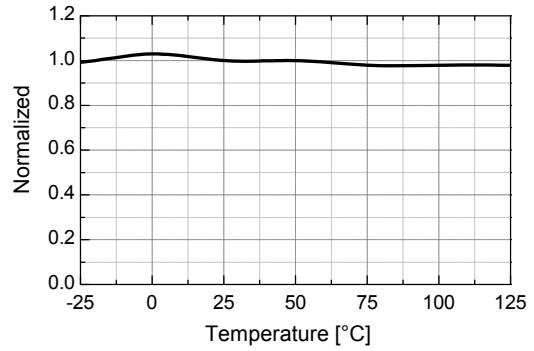

Figure 17. Sync Low Threshold Voltage (V_{SL}) vs. T_A

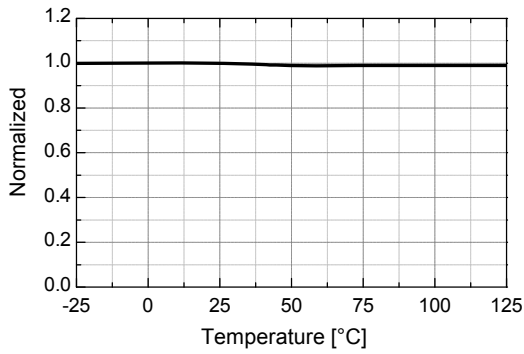

Figure 18. Shutdown Feedback Voltage (V_{SD}) vs. T_A

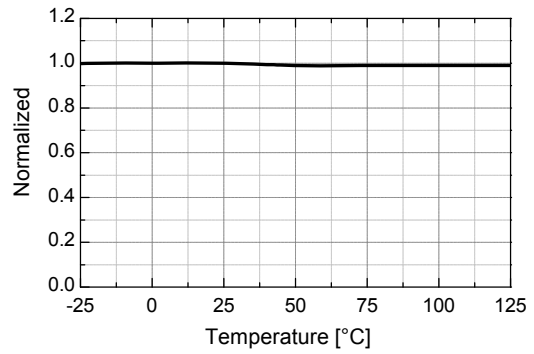

Figure 19. Over-Voltage Protection (V_{OP}) vs. T_A

Functional Description

1. Startup: At startup, an internal high-voltage current source supplies the internal bias and charges the external capacitor (C_a) connected to the V_{CC} pin, as illustrated in Figure 20. When V_{CC} reaches 12V, the FPS™ begins switching and the internal high-voltage current source is disabled. The FPS continues its normal switching operation and the power is supplied from the auxiliary transformer winding unless V_{CC} goes below the stop voltage of 8V.

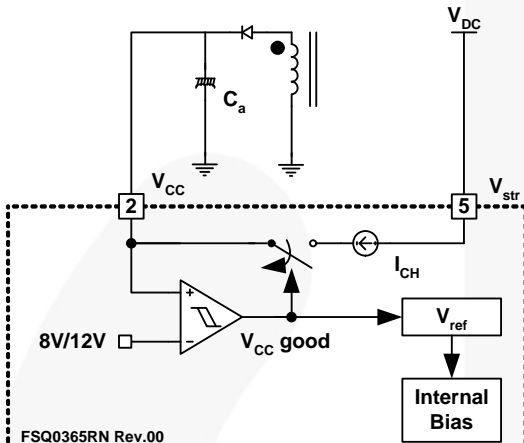
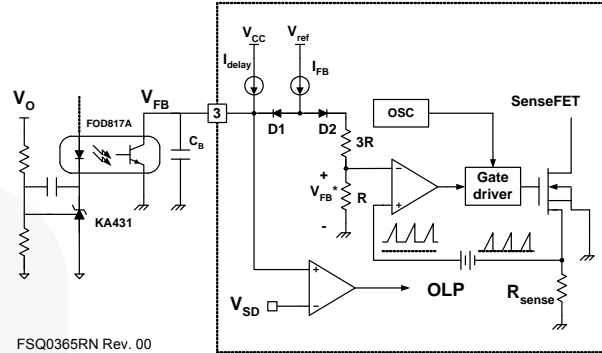

Figure 20. Startup Circuit

2. Feedback Control: FPS employs Current Mode control, as shown in Figure 21. An opto-coupler (such as FOD817A) and shunt regulator (such as KA431) are often used to implement the feedback network. Comparing the feedback voltage with the voltage across the R_{SENSE} resistor makes it possible to control the switching duty cycle. When the reference pin voltage of the shunt regulator exceeds the internal reference voltage of 2.5V, the opto-coupler LED current increases, pulling down the feedback voltage and reducing the duty cycle. This event typically occurs when input voltage is increased or output load is decreased.

2.1 Pulse-by-Pulse Current Limit: Because Current Mode control is employed, the peak current through the SenseFET is limited by the inverting input of PWM comparator (V_{FB}^*), as shown in Figure 21. Assuming that the 0.9mA current source flows only through the internal resistor ($3R + R = 2.8k\Omega$), the cathode voltage of diode D2 is about 2.5V. Since D1 is blocked when the feedback voltage (V_{FB}) exceeds 2.5V, the maximum voltage of the cathode of D2 is clamped at this voltage, clamping V_{FB}^* . Therefore, the peak value of the current through the SenseFET is limited.

2.2 Leading-Edge Blanking (LEB): At the instant the internal SenseFET is turned on, a high-current spike usually occurs through the SenseFET, caused by primary-side capacitance and secondary-side rectifier reverse recovery. Excessive voltage across the R_{sense} resistor would lead to incorrect feedback operation in the Current Mode PWM control. To counter this effect, the FPS employs a leading-edge blanking (LEB) circuit. This circuit inhibits the PWM comparator for a short time (t_{LEB}) after the SenseFET is turned on.



FSQ0365RN Rev. 00

Figure 21. Pulse-Width-Modulation (PWM) Circuit

3. Synchronization: The FSQ-series employs a valley switching technique to minimize the switching noise and loss. The basic waveforms of the valley switching converter are shown in Figure 22. To minimize the MOSFET's switching loss, the MOSFET should be turned on when the drain voltage reaches its minimum value, as shown in Figure 22. The minimum drain voltage is indirectly detected by monitoring the V_{CC} winding voltage, as shown in Figure 22.

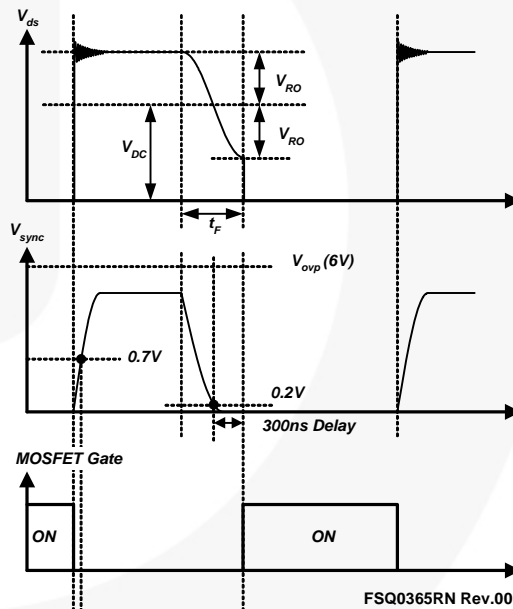

FSQ0365RN Rev.00

Figure 22. Valley Resonant Switching Waveforms

4. Protection Circuits: The FSQ-series has several self-protective functions, such as Overload Protection (OLP), Abnormal Over-Current protection (AOCP), Over-Voltage Protection (OVP), and Thermal Shutdown (TSD). All the protections are implemented as Auto-Restart Mode. Once the fault condition is detected, switching is terminated and the SenseFET remains off. This causes V_{CC} to fall. When V_{CC} falls down to the Under-Voltage Lockout (UVLO) stop voltage of 8V, the protection is reset and the startup circuit charges the V_{CC} capacitor. When the V_{CC} reaches the start voltage of 12V, the FSQ-series resumes normal operation. If the fault condition is not removed, the SenseFET remains off and V_{CC} drops to stop voltage again. In this manner,

the auto-restart can alternately enable and disable the switching of the power SenseFET until the fault condition is eliminated. Because these protection circuits are fully integrated into the IC without external components, the reliability is improved without increasing cost.

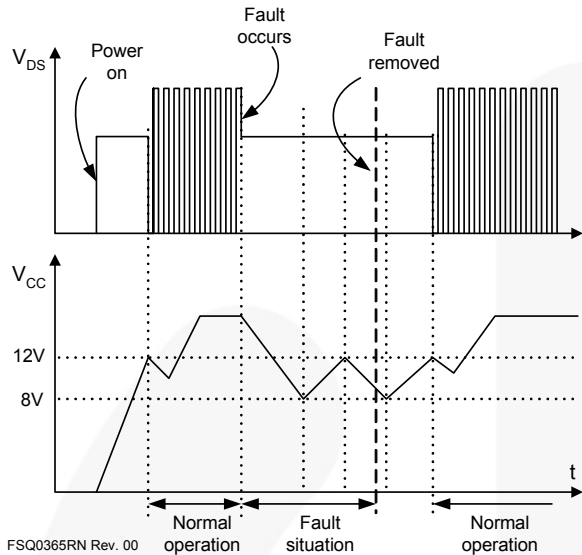

Figure 23. Auto-Restart Protection Waveforms

4.1 Overload Protection (OLP): Overload is defined as the load current exceeding its normal level due to an unexpected abnormal event. In this situation, the protection circuit should trigger to protect the SMPS. However, even when the SMPS is in the normal operation, the overload protection circuit can be triggered during load transition. To avoid this undesired operation, the overload protection circuit is designed to trigger only after a specified time to determine whether it is a transient situation or a true overload situation. Because of the pulse-by-pulse current limit capability, the maximum peak current through the SenseFET is limited, and therefore the maximum input power is restricted with a given input voltage. If the output consumes more than this maximum power, the output voltage (V_O) decreases below the set voltage. This reduces the current through the opto-coupler LED, which also reduces the opto-coupler transistor current, thus increasing the feedback voltage (V_{FB}). If V_{FB} exceeds 2.8V, D1 is blocked and the 5 μ A current source starts to charge CB slowly up to V_{CC} . In this condition, V_{FB} continues increasing until it reaches 6V, when the switching operation is terminated, as shown in Figure 24. The delay for shutdown is the time required to charge CB from 2.8V to 6V with 5 μ A. A 20 ~ 50ms delay is typical for most applications.

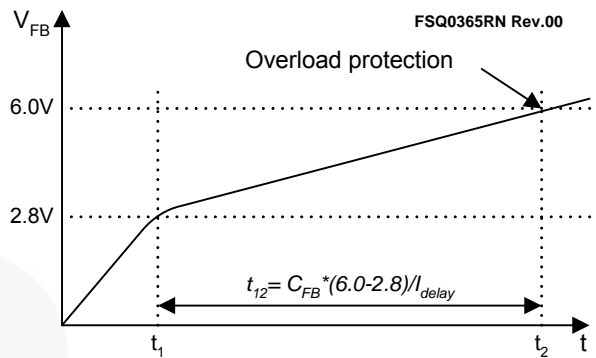

Figure 24. Overload Protection

4.2 Abnormal Over-Current Protection (AOCP): When the secondary rectifier diodes or the transformer pins are shorted, a steep current with extremely high-di/dt can flow through the SenseFET during the LEB time. Even though the FSQ-series has Overload Protection (OLP), it is not enough to protect the FSQ-series in that abnormal case, since severe current stress is imposed on the SenseFET until OLP triggers. The FSQ-series has an internal Abnormal Over-Current Protection (AOCP) circuit as shown in Figure 25. When the gate turn-on signal is applied to the power SenseFET, the AOCP block is enabled and monitors the current through the sensing resistor. The voltage across the resistor is compared with a preset AOCP level. If the sensing resistor voltage is greater than the AOCP level, the set signal is applied to the latch, resulting in the shutdown of the SMPS.

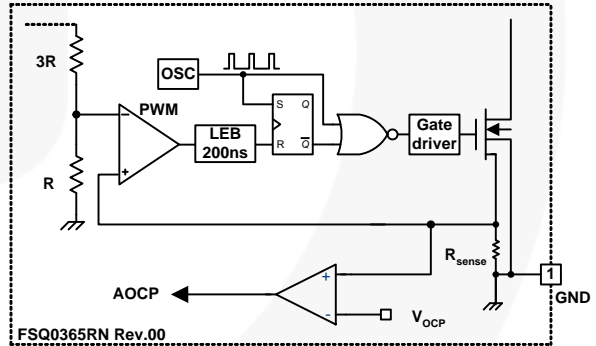

Figure 25. Abnormal Over-Current Protection

4.3 Over-Voltage Protection (OVP): If the secondary-side feedback circuit malfunctions or a solder defect causes an opening in the feedback path, the current through the opto-coupler transistor becomes almost zero. Then V_{FB} climbs up in a similar manner to the overload situation, forcing the preset maximum current to be supplied to the SMPS until the overload protection triggers. Because more energy than required is provided to the output, the output voltage may exceed the rated voltage before the overload protection triggers, resulting in the breakdown of the devices in the secondary side. To prevent this situation, an OVP circuit is employed. In general, the peak voltage of the sync signal is proportional to the output voltage and the FSQ-series uses a sync signal instead of directly monitoring the output voltage. If the sync signal exceeds 6V, an OVP is triggered, shutting down the SMPS. To avoid undesired triggering of OVP during normal operation, the peak voltage of the sync signal should be designed below 6V.

4.4 Thermal Shutdown (TSD): The SenseFET and the control IC are built in one package. This makes it easy for the control IC to detect the abnormal over temperature of the SenseFET. If the temperature exceeds $\sim 150^{\circ}\text{C}$, the thermal shutdown triggers.

5. Soft-Start: An internal soft-start circuit increases PWM comparator inverting input voltage with the SenseFET current slowly after it starts up. The typical soft-start time is 15ms. The pulsewidth to the power switching device is progressively increased to establish the correct working conditions for transformers, inductors, and capacitors. The voltage on the output capacitors is progressively increased with the intention of smoothly establishing the required output voltage. This helps prevent transformer saturation and reduces stress on the secondary diode during startup.

6. Burst Operation: To minimize power dissipation in Standby Mode, the FPS enters Burst-Mode operation. As the load decreases, the feedback voltage decreases. As shown in Figure 26, the device automatically enters Burst Mode when the feedback voltage drops below V_{BURL} (350mV). At this point, switching stops and the output voltages start to drop at a rate dependent on standby current load. This causes the feedback voltage to rise. Once it passes V_{BURH} (550mV), switching resumes. The feedback voltage then falls and the process repeats. Burst Mode alternately enables and disables switching of the power SenseFET, reducing switching loss in Standby Mode.

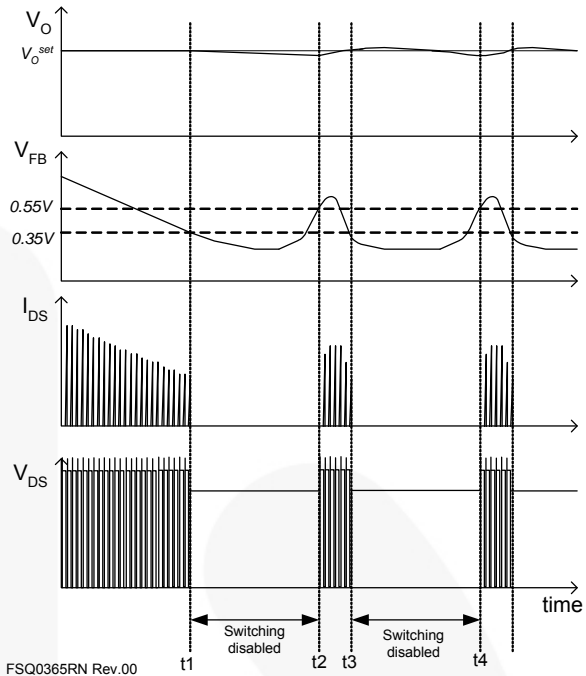

FSQ0365RN Rev.00

Figure 26. Waveforms of Burst Operation

7. Switching Frequency Limit: To minimize switching loss and Electromagnetic Interference (EMI), the MOSFET turns on when the drain voltage reaches its minimum value in valley switching operation. However, this causes switching frequency to increase at light load conditions. As the load decreases, the peak drain current diminishes and the switching frequency increases. This results in severe switching losses at light-load condition, as well as intermittent switching and audible noise. Because of these problems, the valley switching converter topology has limitations in a wide range of applications.

To overcome this problem, FSQ-series employs a frequency-limit function, as shown in Figure 27 and Figure 28. Once the SenseFET is turned on, the next turn-on is prohibited during the blanking time (t_B). After the blanking time, the controller finds the valley within the detection time window (t_W) and turns on the MOSFET, as shown in Figure 27 and Figure 28 (cases A, B, and C). If no valley is found during t_W , the internal SenseFET is forced to turn on at the end of t_W (case D). Therefore, FSQ devices have a minimum switching frequency of 55kHz and a maximum switching frequency of 67kHz, as shown in Figure 28.

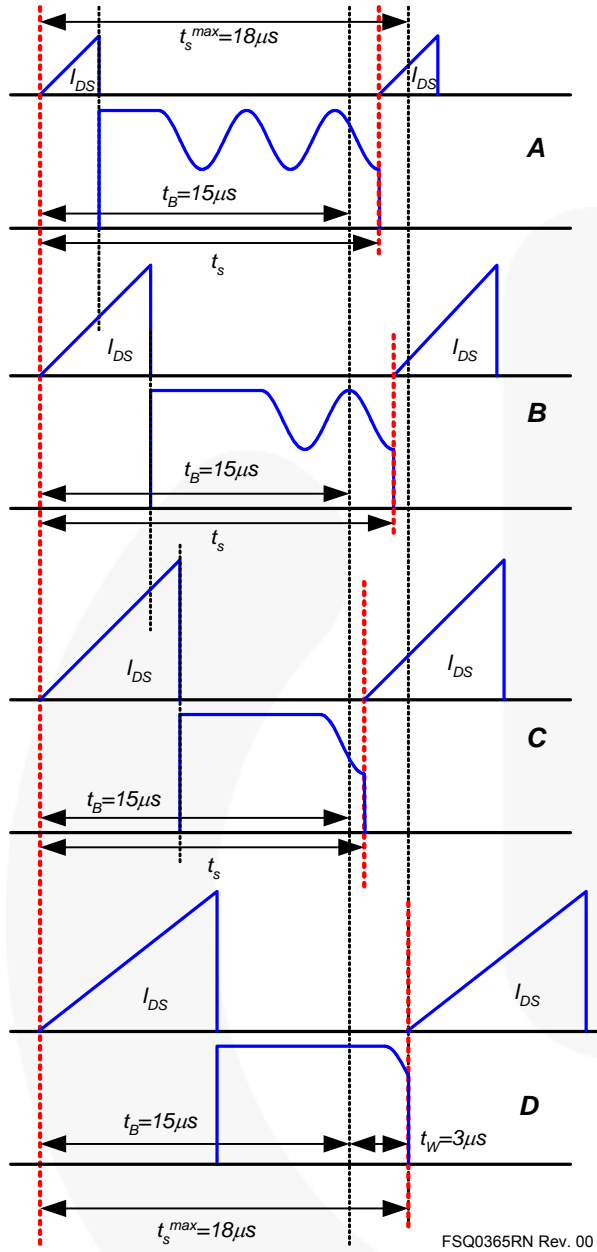
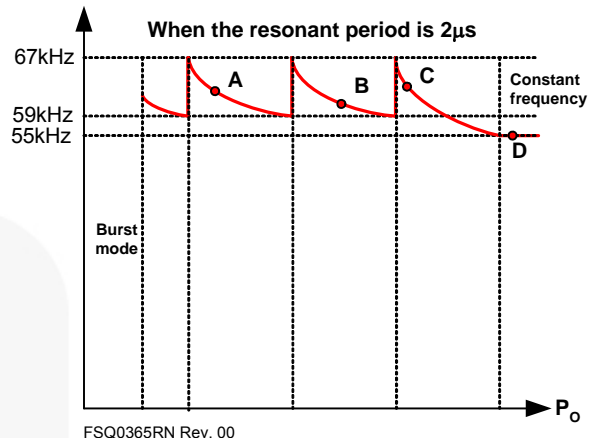

Figure 27. Valley Switching with Limited Frequency



F5Q0365RN Rev. 00

Figure 28. Switching Frequency Range

Typical Application Circuit of FSQ0365RN

Application	FPS Device	Input Voltage Range	Rated Output Power	Output Voltage (Maximum Current)
DVD Player Power Supply	FSQ0365RN	85-265V _{AC}	19W	5.1V (1.0A) 3.4V (1.0A) 12V (0.4A) 16V (0.3A)

Features

- High efficiency (>77% at universal input)
- Low standby mode power consumption (<1W at 230V_{AC} input and 0.5W load)
- Reduce EMI noise through Valley Switching operation
- Enhanced system reliability through various protection functions
- Internal soft-start: 15ms

Key Design Notes

- The delay time for overload protection is designed to be about 30ms with C107 of 47nF. If faster/slower triggering of OLP is required, C107 can be changed to a smaller/larger value (eg. 100nF for 60ms).
- The input voltage of V_{sync} must be higher than -0.3V. By proper voltage sharing by R106 & R107 resistors, the input voltage can be adjusted.
- The SMD-type 100nF capacitor must be placed as close as possible to V_{CC} pin to avoid malfunction by abrupt pulsating noises and to improved surge immunity.

Schematic

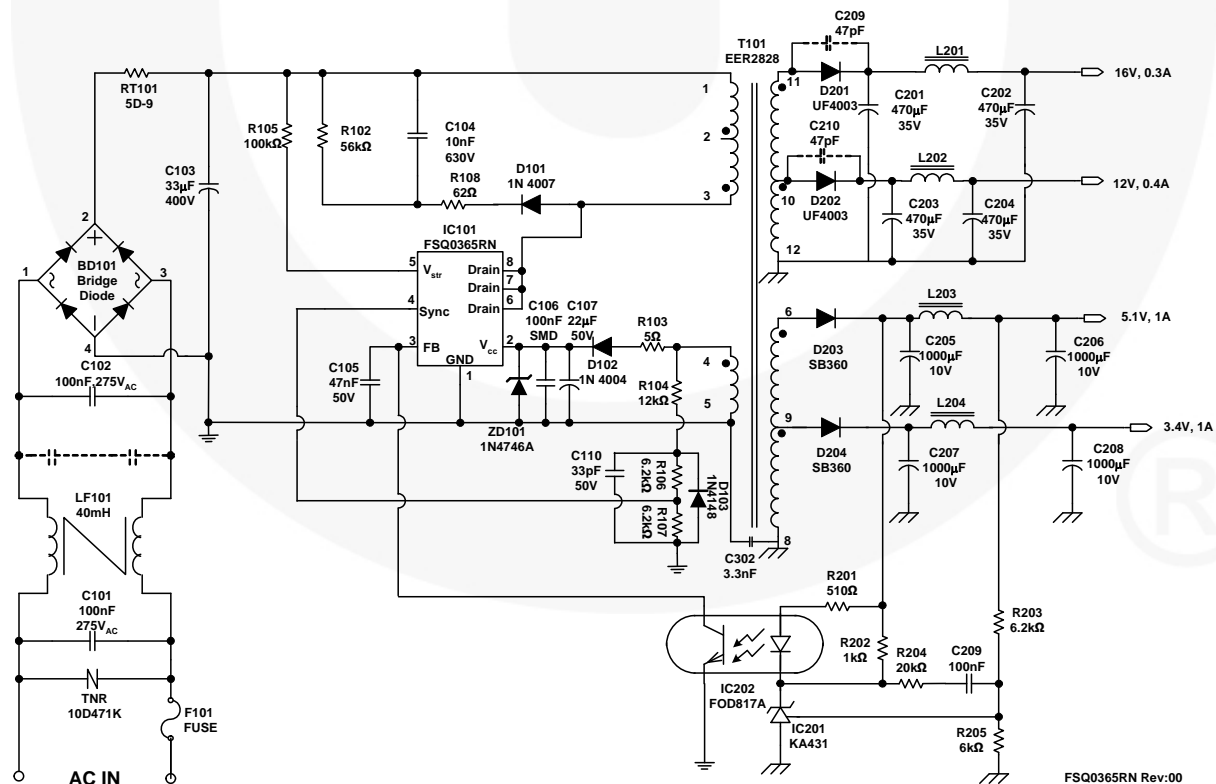

Figure 29. Demo Circuit of FSQ0365RN

Transformer

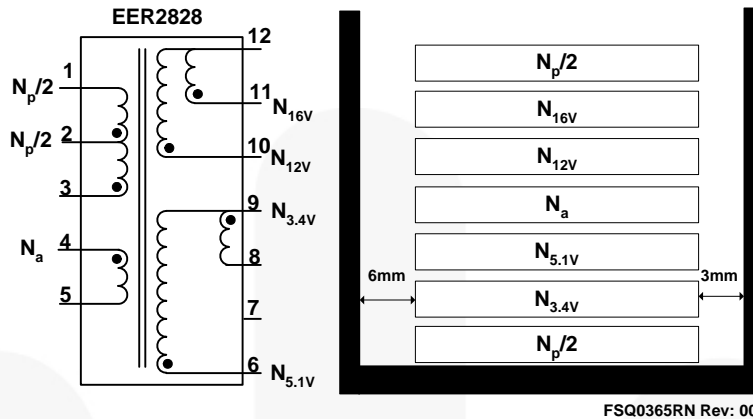

Figure 30. Transformer Schematic Diagram of FSQ0365RN

Table 1. Winding Specification

No.	Pin (s→f)	Wire	Turns	Winding Method
$N_p/2$	3→2	0.25 ^φ x 1	50	Center Solenoid Winding
Insulation: Polyester Tape t = 0.050mm, 2-Layer				
$N_{3.4V}$	9→8	0.33 ^φ x 2	4	Center Solenoid Winding
Insulation: Polyester Tape t = 0.050mm, 2-Layer				
N_{5V}	6→9	0.33 ^φ x 1	2	Center Solenoid Winding
Insulation: Polyester Tape t = 0.050mm, 2-Layer				
N_a	4→5	0.25 ^φ x 1	16	Center Solenoid Winding
Insulation: Polyester Tape t = 0.050mm, 2-Layer				
N_{12V}	10→12	0.33 ^φ x 3	14	Center Solenoid Winding
Insulation: Polyester Tape t = 0.050mm, 3-Layer				
N_{16V}	11→12	0.33 ^φ x 3	18	Center Solenoid Winding
Insulation: Polyester Tape t = 0.050mm, 2-Layer				
$N_p/2$	2→1	0.25 ^φ x 1	50	Center Solenoid Winding
Insulation: Polyester Tape t = 0.050mm, 2-Layer				

Table 2. Electrical Characteristics

	Pin	Specification	Remarks
Inductance	1 - 3	1.4mH ± 10%	100kHz, 1V
Leakage	1 - 3	25μH Maximum	Short All Other Pins

Core & Bobbin

- Core: EER2828 ($A_e=86.66\text{mm}^2$)
- Bobbin: EER2828

Table 3. Demo Board Part List

Part	Value	Note	Part	Value	Note
Resistor			Inductor		
R102	56k \square	1W	L201	10 μ H	
R103	5 \square	1/2W	L202	10 μ H	
R104	12k \square	1/4W	L203	4.9 μ H	
R105	100k \square	1/4W	L204	4.9 μ H	
R106	6.2k \square	1/4W	Diode		
R107	6.2k \square	1/4W	D101	IN4007	
R108	62 \square	1W	D102	IN4004	
R201	510 \square	1/4W	ZD101	1N4746A	
R202	1k \square	1/4W	D103	1N4148	
R203	6.2k \square	1/4W	D201	UF4003	
R204	20k \square	1/4W	D202	UF4003	
R205	6k \square	1/4W	D203	SB360	
Capacitor			D204	SB360	
C101	100nF/275V _{AC}	Box Capacitor			
C102	100nF/275V _{AC}	Box Capacitor	IC		
C103	33 μ F/400V	Electrolytic Capacitor	IC101	FSQ0365RN	FPS™
C104	10nF/630V	Film Capacitor	IC201	KA431 (TL431)	Voltage reference
C105	47nF/50V	Mono Capacitor	IC202	FOD817A	Opto-coupler
C106	100nF/50V	SMD (1206)	Fuse		
C107	22 μ F/50V	Electrolytic Capacitor	Fuse	2A/250V	
C110	33pF/50V	Ceramic Capacitor	NTC		
C201	470 μ F/35V	Electrolytic Capacitor	RT101	5D-9	
C202	470 μ F/35V	Electrolytic Capacitor	Bridge Diode		
C203	470 μ F/35V	Electrolytic Capacitor	BD101	2KBP06M2N257	Bridge Diode
C204	470 μ F/35V	Electrolytic Capacitor	Line Filter		
C205	1000 μ F/10V	Electrolytic Capacitor	LF101	40mH	
C206	1000 μ F/10V	Electrolytic Capacitor	Transformer		
C207	1000 μ F/10V	Electrolytic Capacitor	T101		
C208	1000 μ F/10V	Electrolytic Capacitor	Varistor		
C209	100nF /50V	Ceramic Capacitor	TNR	10D471K	

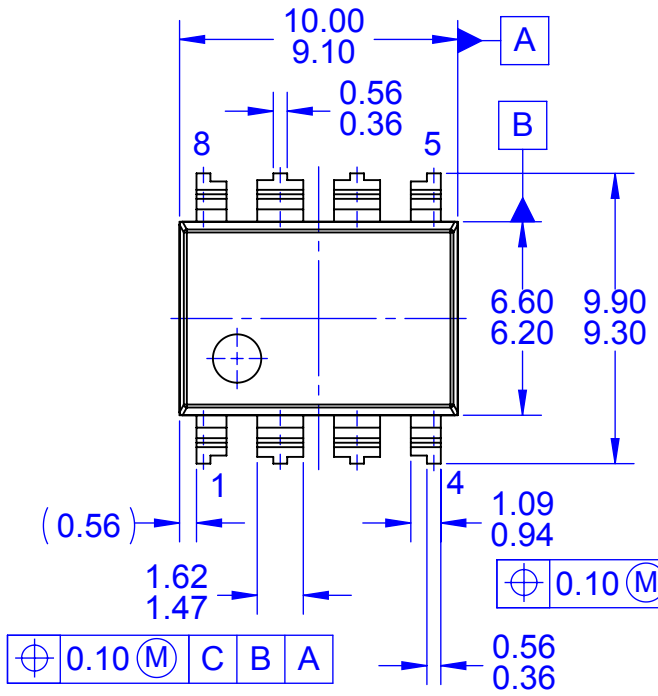

TOP VIEW

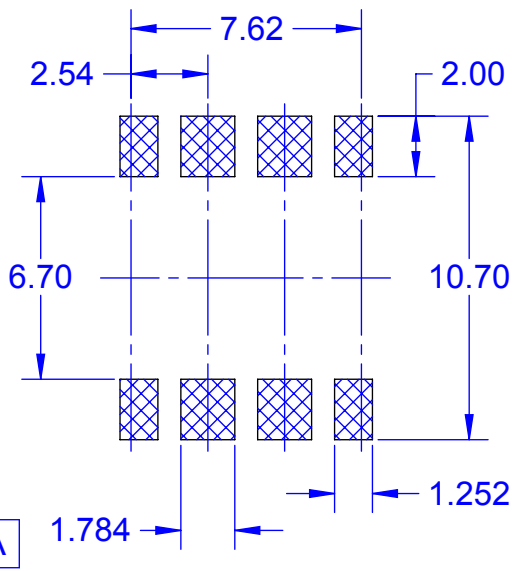

LAND PATTERN RECOMMENDATION

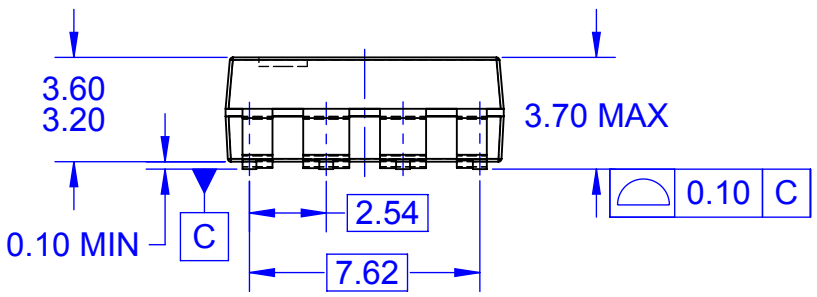

FRONT VIEW

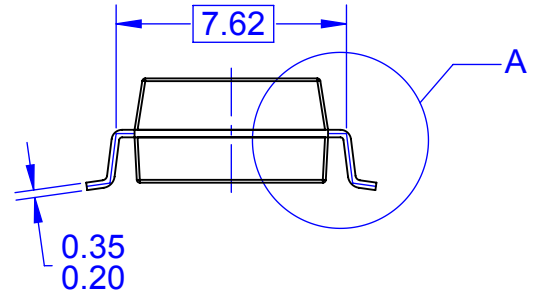

SIDE VIEW

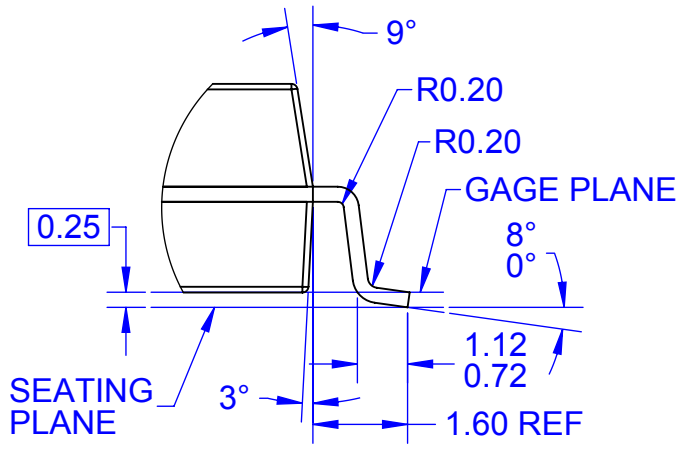

DETAIL A
SCALE 2:1

- NOTES: UNLESS OTHERWISE SPECIFIED
 A. NO INDUSTRY STANDARD APPLIES TO THIS PACKAGE
 B. ALL DIMENSIONS ARE IN MILLIMETERS
 C. DIMENSIONS ARE EXCLUSIVE OF BURRS, MOLD FLASH, AND TIE BAR EXTRUSIONS
 D. DIMENSIONS AND TOLERANCES PER ASME Y14.5M-2009
 E. DRAWING FILENAME: MKT-MLSOP08Arev2



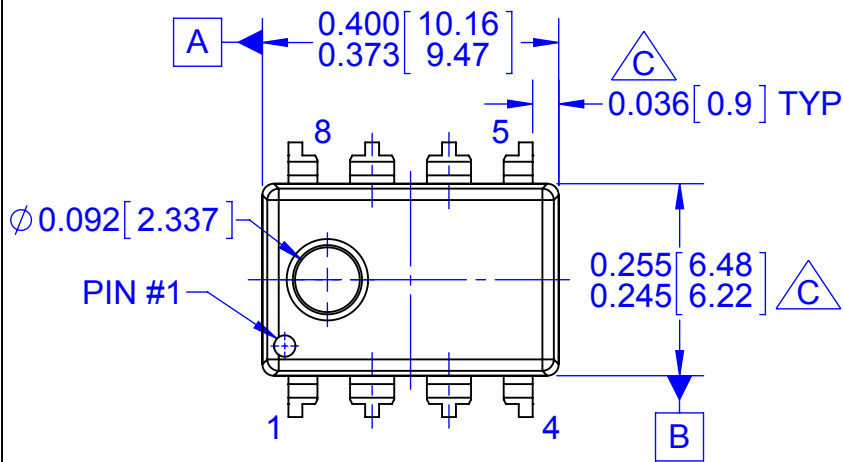

TOP VIEW, OPTION 1

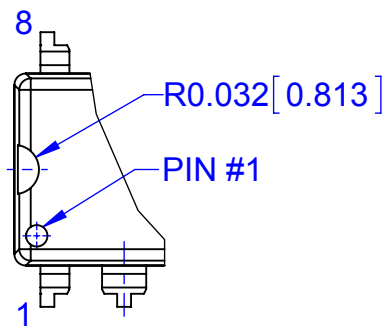

TOP VIEW, OPTION 2

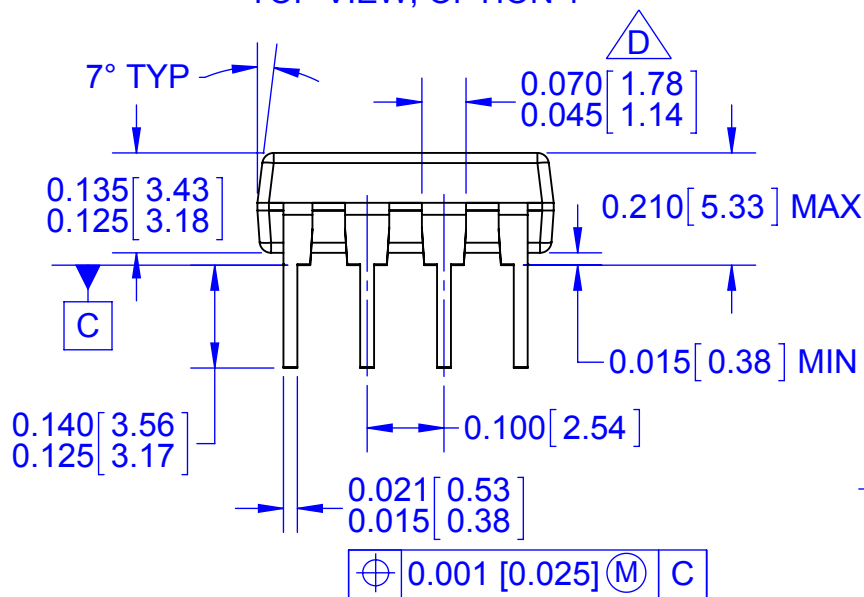

FRONT VIEW

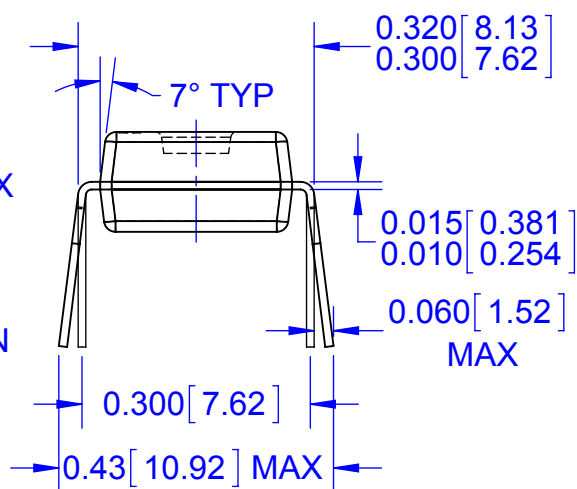

SIDE VIEW

NOTES:

- A. CONFORMS TO JEDEC MS-001, VARIATION BA
- B. CONTROLLING DIMENSIONS ARE IN INCHES.
REFERENCE DIMENSIONS ARE IN MILLIMETERS.

C DOES NOT INCLUDE MOLD FLASH OR PROTRUSIONS.
MOLD FLASH OR PROTRUSIONS SHALL NOT EXCEED
0.010 INCHES OR 0.25MM.

D DOES NOT INCLUDE DAMBAR PROTRUSIONS.
DAMBAR PROTRUSIONS SHALL NOT EXCEED 0.010
INCHES OR 0.25MM.

E. DIMENSIONING AND TOLERANCING PER ASME
Y14.5M-2009

F. DRAWING FILENAME: MKT-N08Erev8



ON Semiconductor and  are trademarks of Semiconductor Components Industries, LLC dba ON Semiconductor or its subsidiaries in the United States and/or other countries. ON Semiconductor owns the rights to a number of patents, trademarks, copyrights, trade secrets, and other intellectual property. A listing of ON Semiconductor's product/patent coverage may be accessed at www.onsemi.com/site/pdf/Patent-Marking.pdf. ON Semiconductor reserves the right to make changes without further notice to any products herein. ON Semiconductor makes no warranty, representation or guarantee regarding the suitability of its products for any particular purpose, nor does ON Semiconductor assume any liability arising out of the application or use of any product or circuit, and specifically disclaims any and all liability, including without limitation special, consequential or incidental damages. Buyer is responsible for its products and applications using ON Semiconductor products, including compliance with all laws, regulations and safety requirements or standards, regardless of any support or applications information provided by ON Semiconductor. "Typical" parameters which may be provided in ON Semiconductor data sheets and/or specifications can and do vary in different applications and actual performance may vary over time. All operating parameters, including "Typicals" must be validated for each customer application by customer's technical experts. ON Semiconductor does not convey any license under its patent rights nor the rights of others. ON Semiconductor products are not designed, intended, or authorized for use as a critical component in life support systems or any FDA Class 3 medical devices or medical devices with a same or similar classification in a foreign jurisdiction or any devices intended for implantation in the human body. Should Buyer purchase or use ON Semiconductor products for any such unintended or unauthorized application, Buyer shall indemnify and hold ON Semiconductor and its officers, employees, subsidiaries, affiliates, and distributors harmless against all claims, costs, damages, and expenses, and reasonable attorney fees arising out of, directly or indirectly, any claim of personal injury or death associated with such unintended or unauthorized use, even if such claim alleges that ON Semiconductor was negligent regarding the design or manufacture of the part. ON Semiconductor is an Equal Opportunity/Affirmative Action Employer. This literature is subject to all applicable copyright laws and is not for resale in any manner.

PUBLICATION ORDERING INFORMATION

LITERATURE FULFILLMENT:

Literature Distribution Center for ON Semiconductor
19521 E. 32nd Pkwy, Aurora, Colorado 80011 USA
Phone: 303-675-2175 or 800-344-3860 Toll Free USA/Canada
Fax: 303-675-2176 or 800-344-3867 Toll Free USA/Canada
Email: orderlit@onsemi.com

N. American Technical Support: 800-282-9855 Toll Free
USA/Canada
Europe, Middle East and Africa Technical Support:
Phone: 421 33 790 2910
Japan Customer Focus Center
Phone: 81-3-5817-1050

ON Semiconductor Website: www.onsemi.com
Order Literature: <http://www.onsemi.com/orderlit>
For additional information, please contact your local
Sales Representative

Looking for pricing, stock, or lifecycle information?

Click below to explore more details on WIN SOURCE:

-  [View FSQ321LX on WIN SOURCE](#)
-  [Fairchild/ON Semiconductor](#) Information

Optimize Your Supply Chain with WIN SOURCE Solutions

-  Global Sourcing Solution
-  Obsolete Management
-  Cost Control Management
-  Shortage Management
-  Alternative Solution
-  Excess Inventory Management