



# MC100EPT21

## 3.3V Differential LVPECL/LVDS/CML to LVTTTL/LVCMOS Translator

The MC100EPT21 is a Differential LVPECL/LVDS/CML to LVTTTL/LVCMOS translator. Because LVPECL (Positive ECL), LVDS, and positive CML input levels and LVTTTL/LVCMOS output levels are used, only +3.3 V and ground are required. The small outline 8-lead SOIC package makes the EPT21 ideal for applications which require the translation of a clock or data signal.

The  $V_{BB}$  output allows this EPT21 to be cap coupled in either single-ended or differential input mode. When single-ended cap coupled,  $V_{BB}$  output is tied to the  $\bar{D}$  input and D is driven for a non-inverting buffer, or  $V_{BB}$  output is tied to the D input and  $\bar{D}$  is driven for an inverting buffer. When cap coupled differentially,  $V_{BB}$  output is connected through a resistor to each input pin. If used, the  $V_{BB}$  pin should be bypassed to  $V_{CC}$  via a 0.01  $\mu\text{F}$  capacitor. For additional information see AND8020/D. For a single-ended direct connection use an external voltage reference source such as a resistor divider. Do not use  $V_{BB}$  for a single-ended direct connection or port to another device.

### Features

- 1.4 ns Typical Propagation Delay
- Maximum Frequency > 275 MHz Typical
- LVPECL/LVDS/CML Inputs, LVTTTL/LVCMOS Outputs
- 24 mA TTL outputs
- Operating Range:  $V_{CC} = 3.0\text{ V}$  to  $3.6\text{ V}$  with  $GND = 0\text{ V}$
- The 100 Series Contains Temperature Compensation
- $V_{BB}$  Output
- These Devices are Pb-Free and are RoHS Compliant



ON Semiconductor®

<http://onsemi.com>

### MARKING DIAGRAMS\*

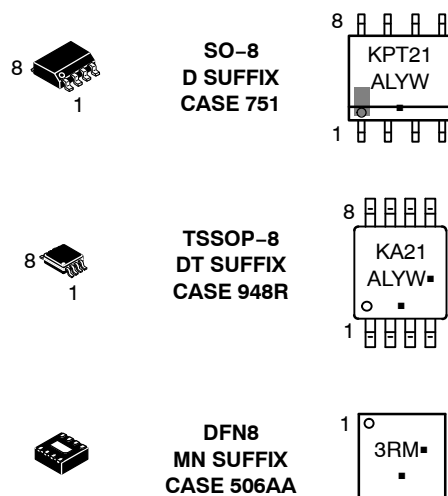

A = Assembly Location  
L = Wafer Lot  
Y = Year  
W = Work Week  
M = Date Code  
▪ = Pb-Free Package

(Note: Microdot may be in either location)

\*For additional marking information, refer to Application Note AND8002/D.

### ORDERING INFORMATION

See detailed ordering and shipping information in the package dimensions section on page 6 of this data sheet.

# MC100EPT21

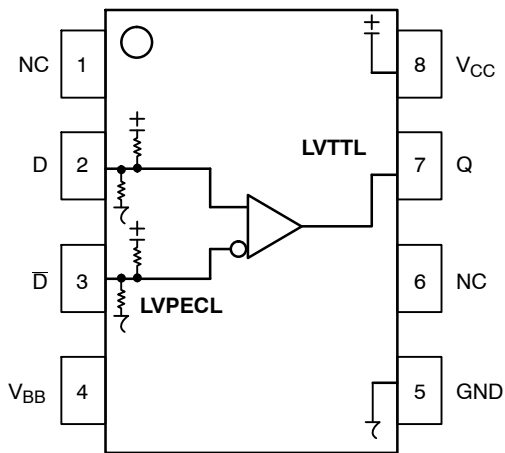

Figure 1. Logic Diagram and 8-Lead Pinout (Top View)

Table 1. PIN DESCRIPTION

PIN	FUNCTION
Q	LVTTTL/LVCMOS Output
D*, $\bar{D}$ *	Differential LVPECL/LVDS/CML Input
V <sub>CC</sub>	Positive Supply
V <sub>BB</sub>	Output Reference Voltage
GND	Ground
NC	No Connect
EP	(DFN8 only) Thermal exposed pad must be connected to a sufficient thermal conduit. Electrically connect to the most negative supply (GND) or leave unconnected, floating open.

\* Pin will default to 1/2 of V<sub>CC</sub> when left open.

Table 2. ATTRIBUTES

Characteristics	Value
Internal Input Pulldown Resistor	D 50 kΩ
Internal Input Pulldown Resistor	$\bar{D}$ 50 kΩ
Internal Input Pullup Resistor	D, $\bar{D}$ 50 kΩ
ESD Protection	Human Body Model > 1.5 kV Machine Model > 100 V Charged Device Model > 2 kV
Moisture Sensitivity, Indefinite Time Out of Drypack (Note 1)	SOIC-8 Level 1 TSSOP-8 Level 3 DFN8 Level 1
Flammability Rating	Oxygen Index: 28 to 34 UL 94 V-0 @ 0.125 in
Transistor Count	81 Devices
Meets or exceeds JEDEC Spec EIA/JESD78 IC Latchup Test	

1. For additional information, see Application Note AND8003/D.

# MC100EPT21

**Table 3. MAXIMUM RATINGS**

Symbol	Parameter	Condition 1	Condition 2	Rating	Unit
V <sub>CC</sub>	PECL Power Supply	GND = 0 V		3.8	V
V <sub>IN</sub>	PECL Input Voltage	GND = 0 V	V <sub>I</sub> ≤ V <sub>CC</sub>	0 to 3.8	V
I <sub>BB</sub>	V <sub>BB</sub> Sink/Source			± 0.5	mA
T <sub>A</sub>	Operating Temperature Range			-40 to +85	°C
T <sub>stg</sub>	Storage Temperature Range			-65 to +150	°C
θ <sub>JA</sub>	Thermal Resistance (Junction-to-Ambient)	0 lfpm 500 lfpm	SO-8 SO-8	190 130	°C/W °C/W
θ <sub>JC</sub>	Thermal Resistance (Junction-to-Case)	Standard Board	SO-8	41 to 44	°C/W
θ <sub>JA</sub>	Thermal Resistance (Junction-to-Ambient)	0 lfpm 500 lfpm	TSSOP-8 TSSOP-8	185 140	°C/W °C/W
θ <sub>JC</sub>	Thermal Resistance (Junction-to-Case)	Standard Board	TSSOP-8	41 to 44	°C/W
θ <sub>JA</sub>	Thermal Resistance (Junction-to-Ambient)	0 lfpm 500 lfpm	DFN8 DFN8	129 84	°C/W °C/W
T <sub>sol</sub>	Wave Solder	Pb Pb-Free	< 2 to 3 sec @ 248°C < 2 to 3 sec @ 260°C	265 265	°C
θ <sub>JC</sub>	Thermal Resistance (Junction-to-Case)	(Note 2)	DFN8	35 to 40	°C/W

Stresses exceeding Maximum Ratings may damage the device. Maximum Ratings are stress ratings only. Functional operation above the Recommended Operating Conditions is not implied. Extended exposure to stresses above the Recommended Operating Conditions may affect device reliability.

2. JEDEC standard multilayer board – 2S2P (2 signal, 2 power)

**Table 4. PECL INPUT DC CHARACTERISTICS** V<sub>CC</sub> = 3.3 V, GND = 0.0 V (Note 3)

Symbol	Characteristic	-40°C			25°C			85°C			Unit
		Min	Typ	Max	Min	Typ	Max	Min	Typ	Max	
V <sub>IH</sub>	Input HIGH Voltage (Single-Ended)	2075		2420	2075		2420	2075		2420	mV
V <sub>IL</sub>	Input LOW Voltage (Single-Ended)	1355		1675	1355		1675	1355		1675	mV
V <sub>BB</sub>	Output Voltage Reference	1775	1875	1975	1775	1875	1975	1775	1875	1975	mV
V <sub>IHCMR</sub>	Input HIGH Voltage Common Mode Range (Differential Configuration) (Note 4)	1.2		3.3	1.2		3.3	1.2		3.3	V
I <sub>IH</sub>	Input HIGH Current			150			150			150	μA
I <sub>IL</sub>	Input LOW Current	-150			-150			-150			μA

NOTE: Device will meet the specifications after thermal equilibrium has been established when mounted in a test socket or printed circuit board with maintained transverse airflow greater than 500 lfpm. Electrical parameters are guaranteed only over the declared operating temperature range. Functional operation of the device exceeding these conditions is not implied. Device specification limit values are applied individually under normal operating conditions and not valid simultaneously.

3. Input parameters vary 1:1 with V<sub>CC</sub>.

4. V<sub>IHCMR</sub> min varies 1:1 with GND, V<sub>IHCMR</sub> max varies 1:1 with V<sub>CC</sub>. The V<sub>IHCMR</sub> range is referenced to the most positive side of the differential input signal.

# MC100EPT21

**Table 5. LVTTTL/LVCMOS OUTPUT DC CHARACTERISTICS**  $V_{CC} = 3.3\text{ V}$ ,  $GND = 0.0\text{ V}$ ,  $T_A = -40^\circ\text{C}$  to  $85^\circ\text{C}$

Symbol	Characteristic	Condition	Min	Typ	Max	Unit
$V_{OH}$	Output HIGH Voltage	$I_{OH} = -3.0\text{ mA}$	2.4			V
$V_{OL}$	Output LOW Voltage	$I_{OL} = 24\text{ mA}$			0.5	V
$I_{CCH}$	Power Supply Current	Outputs set to HIGH	5	17	25	mA
$I_{CCL}$	Power Supply Current	Outputs set to LOW	8	21	30	mA
$I_{OS}$	Output Short Circuit Current		-130		-80	mA

NOTE: Device will meet the specifications after thermal equilibrium has been established when mounted in a test socket or printed circuit board with maintained transverse airflow greater than 500 lfm. Electrical parameters are guaranteed only over the declared operating temperature range. Functional operation of the device exceeding these conditions is not implied. Device specification limit values are applied individually under normal operating conditions and not valid simultaneously.

**Table 6. AC CHARACTERISTICS**  $V_{CC} = 3.0\text{ V}$  to  $3.6\text{ V}$ ,  $GND = 0.0\text{ V}$  (Note 5)

Symbol	Characteristic	$-40^\circ\text{C}$			$25^\circ\text{C}$			$85^\circ\text{C}$			Unit
		Min	Typ	Max	Min	Typ	Max	Min	Typ	Max	
$f_{max}$	Maximum Frequency (Figure 2)	275	350		275	350		275	350		MHz
$t_{PLH}$ , $t_{PHL}$	Propagation Delay to Output Differential	800 1200	1400 1400	2050 1800	800 1200	1400 1400	2250 1800	900 1100	1600 1300	2950 1900	ps
$t_{SKEW}$	Duty Cycle Skew (Note 6)	45	50	55	45	50	55	45	50	55	%
$t_{SKPP}$	Part-to-Part Skew (Note 6)			500			500			500	ps
$t_{JITTER}$	Random Clock Jitter (RMS)		3.5	5		3.5	5		3.5	5	ps
$V_{PP}$	Input Voltage Swing (Differential Configuration)	150	800	1200	150	800	1200	150	800	1200	mV
$t_r$ , $t_f$	Output Rise/Fall Times (0.8V – 2.0V) Q, $\bar{Q}$	250	600	900	250	600	900	250	600	900	ps

NOTE: Device will meet the specifications after thermal equilibrium has been established when mounted in a test socket or printed circuit board with maintained transverse airflow greater than 500 lfm. Electrical parameters are guaranteed only over the declared operating temperature range. Functional operation of the device exceeding these conditions is not implied. Device specification limit values are applied individually under normal operating conditions and not valid simultaneously.

5. Measured with a 750 mV 50% duty-cycle clock source.  $R_L = 500\ \Omega$  to GND and  $C_L = 20\text{ pF}$  to GND. Refer to Figure 3.
6. Skews are measured between outputs under identical transitions. Duty cycle skew is measured between differential outputs using the deviations of the sum  $T_{pw-}$  and  $T_{pw+}$ .

# MC100EPT21

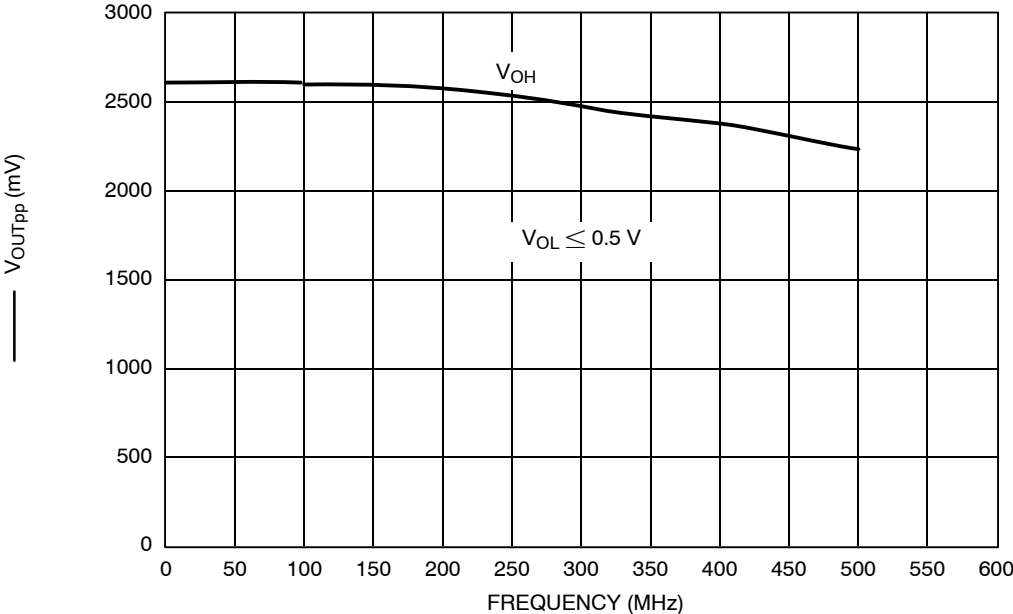

Figure 2.  $F_{max}$

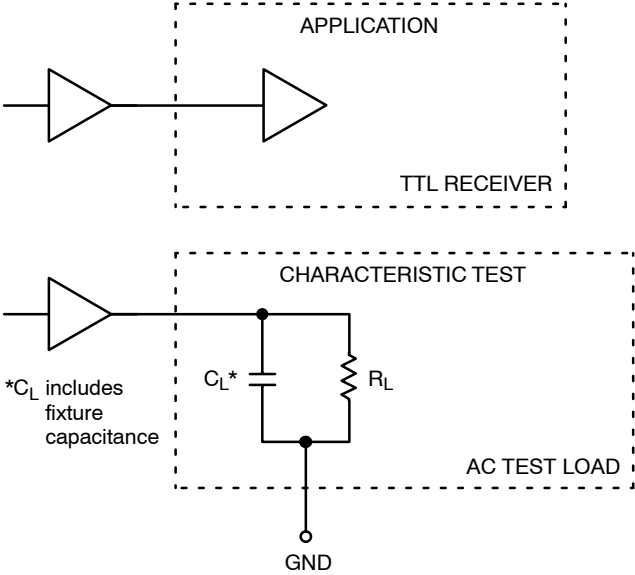

Figure 3. TTL Output Loading Used For Device Evaluation

# MC100EPT21

## ORDERING INFORMATION

Device	Package	Shipping†
MC100EPT21DG	SOIC-8 (Pb-Free)	98 Units / Rail
MC100EPT21DR2G	SOIC-8 (Pb-Free)	2500 / Tape & Reel
MC100EPT21DTG	TSSOP-8 (Pb-Free)	100 Units / Rail
MC100EPT21DTR2G	TSSOP-8 (Pb-Free)	2500 / Tape & Reel
MC100EPT21MNR4G	DFN8 (Pb-Free)	1000 / Tape & Reel

†For information on tape and reel specifications, including part orientation and tape sizes, please refer to our Tape and Reel Packaging Specifications Brochure, BRD8011/D.

### Resource Reference of Application Notes

- AN1405/D** - ECL Clock Distribution Techniques
- AN1406/D** - Designing with PECL (ECL at +5.0 V)
- AN1503/D** - ECLinPS™ I/O SPICE Modeling Kit
- AN1504/D** - Metastability and the ECLinPS Family
- AN1568/D** - Interfacing Between LVDS and ECL
- AN1672/D** - The ECL Translator Guide
- AND8001/D** - Odd Number Counters Design
- AND8002/D** - Marking and Date Codes
- AND8020/D** - Termination of ECL Logic Devices
- AND8066/D** - Interfacing with ECLinPS
- AND8090/D** - AC Characteristics of ECL Devices

# MC100EPT21

## PACKAGE DIMENSIONS

SOIC-8 NB  
CASE 751-07  
ISSUE AK

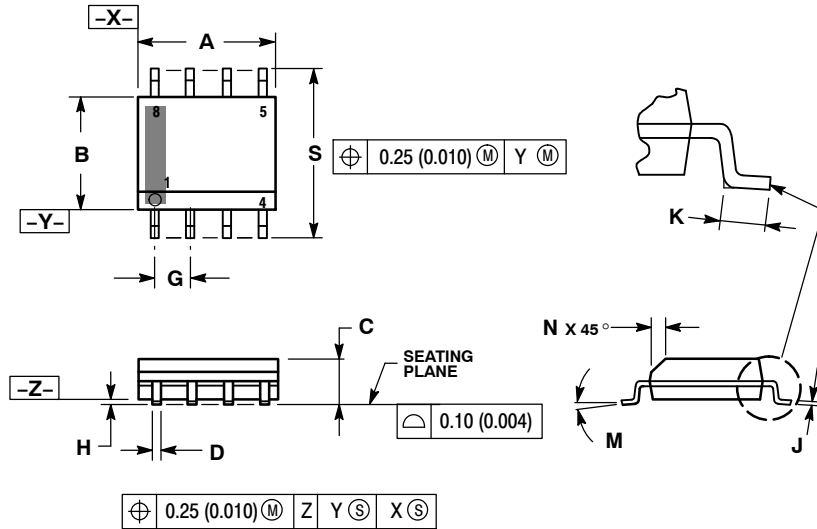

**NOTES:**

1. DIMENSIONING AND TOLERANCING PER ANSI Y14.5M, 1982.
2. CONTROLLING DIMENSION: MILLIMETER.
3. DIMENSION A AND B DO NOT INCLUDE MOLD PROTRUSION.
4. MAXIMUM MOLD PROTRUSION 0.15 (0.006) PER SIDE.
5. DIMENSION D DOES NOT INCLUDE DAMBAR PROTRUSION. ALLOWABLE DAMBAR PROTRUSION SHALL BE 0.127 (0.005) TOTAL IN EXCESS OF THE D DIMENSION AT MAXIMUM MATERIAL CONDITION.
6. 751-01 THRU 751-06 ARE OBSOLETE. NEW STANDARD IS 751-07.

DIM	MILLIMETERS		INCHES	
	MIN	MAX	MIN	MAX
A	4.80	5.00	0.189	0.197
B	3.80	4.00	0.150	0.157
C	1.35	1.75	0.053	0.069
D	0.33	0.51	0.013	0.020
G	1.27 BSC		0.050 BSC	
H	0.10	0.25	0.004	0.010
J	0.19	0.25	0.007	0.010
K	0.40	1.27	0.016	0.050
M	0°	8°	0°	8°
N	0.25	0.50	0.010	0.020
S	5.80	6.20	0.228	0.244

### SOLDERING FOOTPRINT\*

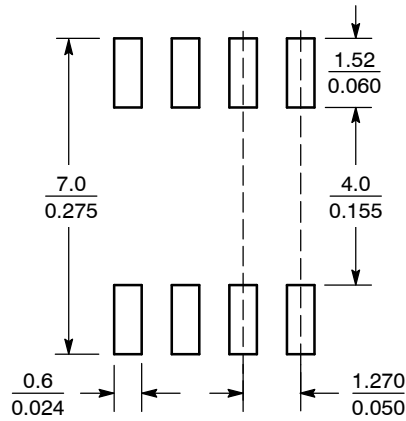

SCALE 6:1  $\left(\frac{\text{mm}}{\text{inches}}\right)$

\*For additional information on our Pb-Free strategy and soldering details, please download the ON Semiconductor Soldering and Mounting Techniques Reference Manual, SOLDERRM/D.

# MC100EPT21

## PACKAGE DIMENSIONS

TSSOP-8  
DT SUFFIX  
CASE 948R-02  
ISSUE A

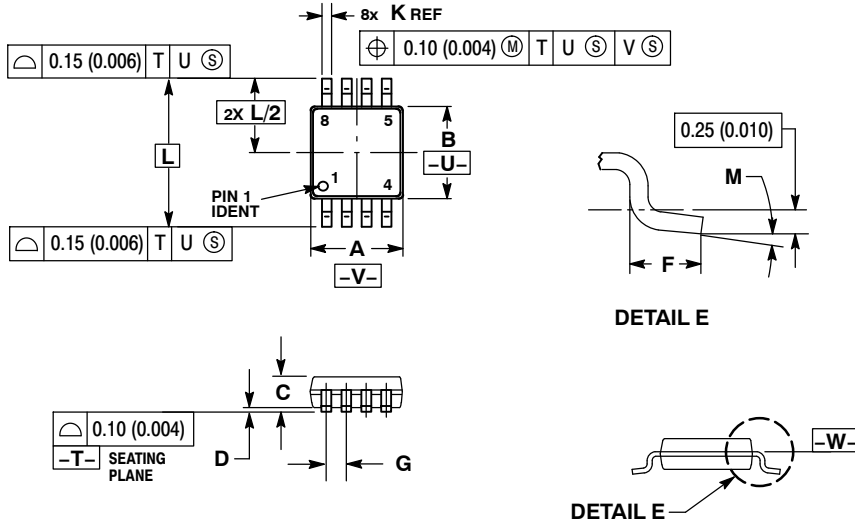

### NOTES:

1. DIMENSIONING AND TOLERANCING PER ANSI Y14.5M, 1982.
2. CONTROLLING DIMENSION: MILLIMETER.
3. DIMENSION A DOES NOT INCLUDE MOLD FLASH, PROTRUSIONS OR GATE BURRS. MOLD FLASH OR GATE BURRS SHALL NOT EXCEED 0.15 (0.006) PER SIDE.
4. DIMENSION B DOES NOT INCLUDE INTERLEAD FLASH OR PROTRUSION. INTERLEAD FLASH OR PROTRUSION SHALL NOT EXCEED 0.25 (0.010) PER SIDE.
5. TERMINAL NUMBERS ARE SHOWN FOR REFERENCE ONLY.
6. DIMENSION A AND B ARE TO BE DETERMINED AT DATUM PLANE -W-.

DIM	MILLIMETERS		INCHES	
	MIN	MAX	MIN	MAX
A	2.90	3.10	0.114	0.122
B	2.90	3.10	0.114	0.122
C	0.80	1.10	0.031	0.043
D	0.05	0.15	0.002	0.006
F	0.40	0.70	0.016	0.028
G	0.65 BSC		0.026 BSC	
K	0.25	0.40	0.010	0.016
L	4.90 BSC		0.193 BSC	
M	0°	6°	0°	6°

# MC100EPT21

## PACKAGE DIMENSIONS

DFN8 2x2, 0.5P  
CASE 506AA  
ISSUE E

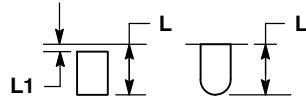
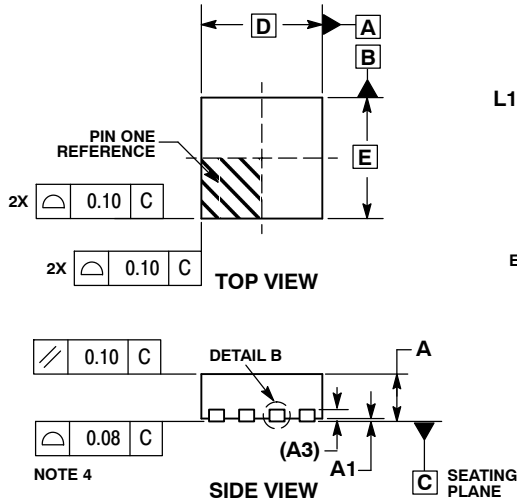

DETAIL A  
OPTIONAL  
CONSTRUCTIONS

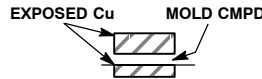

DETAIL B  
OPTIONAL  
CONSTRUCTION

NOTES:

1. DIMENSIONING AND TOLERANCING PER ASME Y14.5M, 1994 .
2. CONTROLLING DIMENSION: MILLIMETERS.
3. DIMENSION b APPLIES TO PLATED TERMINAL AND IS MEASURED BETWEEN 0.15 AND 0.20 MM FROM TERMINAL TIP.
4. COPLANARITY APPLIES TO THE EXPOSED PAD AS WELL AS THE TERMINALS.

DIM	MILLIMETERS	
	MIN	MAX
A	0.80	1.00
A1	0.00	0.05
A3	0.20 REF	
b	0.20	0.30
D	2.00 BSC	
D2	1.10	1.30
E	2.00 BSC	
E2	0.70	0.90
e	0.50 BSC	
K	0.30 REF	
L	0.25	0.35
L1	---	0.10

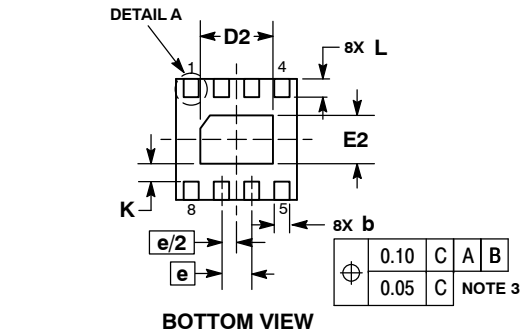

BOTTOM VIEW

### RECOMMENDED SOLDERING FOOTPRINT\*

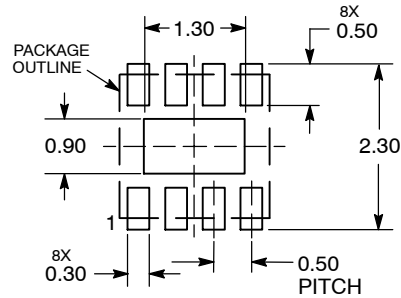

DIMENSIONS: MILLIMETERS

\*For additional information on our Pb-Free strategy and soldering details, please download the ON Semiconductor Soldering and Mounting Techniques Reference Manual, SOLDERRM/D.

ECLinPS is a trademark of Semiconductor Components Industries, LLC (SCILLC).

ON Semiconductor and are registered trademarks of Semiconductor Components Industries, LLC (SCILLC). SCILLC owns the rights to a number of patents, trademarks, copyrights, trade secrets, and other intellectual property. A listing of SCILLC's product/patent coverage may be accessed at [www.onsemi.com/site/pdf/Patent-Marking.pdf](http://www.onsemi.com/site/pdf/Patent-Marking.pdf). SCILLC reserves the right to make changes without further notice to any products herein. SCILLC makes no warranty, representation or guarantee regarding the suitability of its products for any particular purpose, nor does SCILLC assume any liability arising out of the application or use of any product or circuit, and specifically disclaims any and all liability, including without limitation special, consequential or incidental damages. "Typical" parameters which may be provided in SCILLC data sheets and/or specifications can and do vary in different applications and actual performance may vary over time. All operating parameters, including "Typicals" must be validated for each customer application by customer's technical experts. SCILLC does not convey any license under its patent rights nor the rights of others. SCILLC products are not designed, intended, or authorized for use as components in systems intended for surgical implant into the body, or other applications intended to support or sustain life, or for any other application in which the failure of the SCILLC product could create a situation where personal injury or death may occur. Should Buyer purchase or use SCILLC products for any such unintended or unauthorized application, Buyer shall indemnify and hold SCILLC and its officers, employees, subsidiaries, affiliates, and distributors harmless against all claims, costs, damages, and expenses, and reasonable attorney fees arising out of, directly or indirectly, any claim of personal injury or death associated with such unintended or unauthorized use, even if such claim alleges that SCILLC was negligent regarding the design or manufacture of the part. SCILLC is an Equal Opportunity/Affirmative Action Employer. This literature is subject to all applicable copyright laws and is not for resale in any manner.

### PUBLICATION ORDERING INFORMATION

**LITERATURE FULFILLMENT:**  
Literature Distribution Center for ON Semiconductor  
P.O. Box 5163, Denver, Colorado 80217 USA  
Phone: 303-675-2175 or 800-344-3860 Toll Free USA/Canada  
Fax: 303-675-2176 or 800-344-3867 Toll Free USA/Canada  
Email: [orderlit@onsemi.com](mailto:orderlit@onsemi.com)

**N. American Technical Support:** 800-282-9855 Toll Free  
USA/Canada  
**Europe, Middle East and Africa Technical Support:**  
Phone: 421 33 790 2910  
**Japan Customer Focus Center**  
Phone: 81-3-5817-1050

**ON Semiconductor Website:** [www.onsemi.com](http://www.onsemi.com)  
**Order Literature:** <http://www.onsemi.com/orderlit>

For additional information, please contact your local Sales Representative

## Looking for pricing, stock, or lifecycle information?

Click below to explore more details on WIN SOURCE:

 [View MC100EPT21DG](#) on WIN SOURCE

 [ON Semiconductor](#) Information

## Optimize Your Supply Chain with WIN SOURCE Solutions

-  Global Sourcing Solution
-  Obsolete Management
-  Cost Control Management
-  Shortage Management
-  Alternative Solution
-  Excess Inventory Management