



**THE DATASHEET OF  
SN75DP118RHR**



## DisplayPort 1:1 Buffer

### FEATURES

- Supports Data Rates up to 2.7 Gbps
- Supports Dual-Mode DisplayPort
- Output Waveform Mimics Input Waveform Characteristics
- Enhanced ESD: 12 KV on all pins
- Enhanced Commercial Temperature Range: 0°C to 85°C
- 36 Pin 6 × 6 QFN Package

### APPLICATIONS

- Personal Computer Market
  - Desktop PC
  - Notebook PC
  - Docking Station
  - Standalone Video Card

### DESCRIPTION

The SN75DP118 is a one Dual-Mode DisplayPort input to one Dual-Mode DisplayPort output. The output follows the input signal in a manner that provides the highest level of signal integrity while supporting the EMI benefits of spread spectrum clocking. The SN75DP118 data rates of up to 2.7 Gbps through each link for a total throughput of up to 10.8 Gbps can be realized.

In addition to the DisplayPort high speed signal lines, the SN75DP118 also supports the Hot Plug Detect (HPD) and Cable Adapter Detect (CAD) channels.

The SN75DP118 is characterized for operation over ambient air temperature of 0°C to 85°C.

### TYPICAL APPLICATION

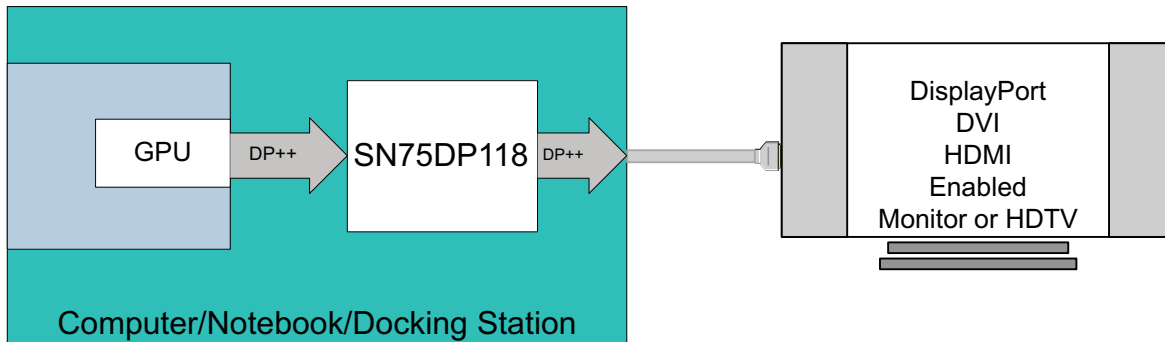

Please be aware that an important notice concerning availability, standard warranty, and use in critical applications of Texas Instruments semiconductor products and disclaimers thereto appears at the end of this data sheet.



These devices have limited built-in ESD protection. The leads should be shorted together or the device placed in conductive foam during storage or handling to prevent electrostatic damage to the MOS gates.

### DATA FLOW BLOCK DIAGRAM

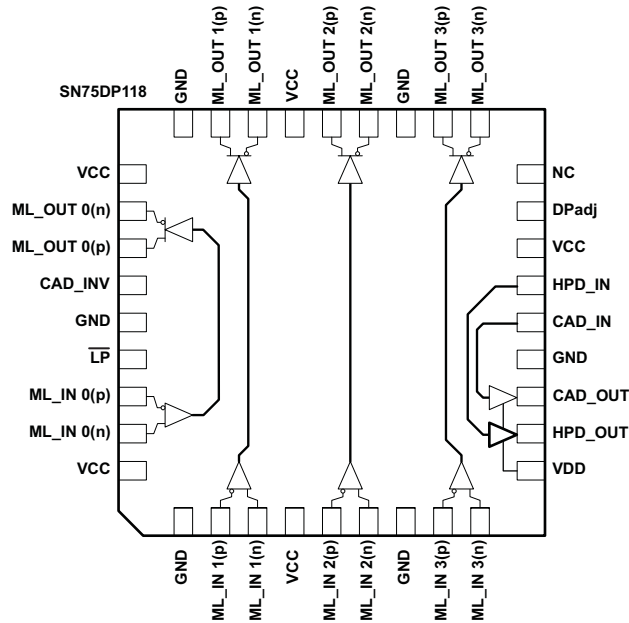

### PACKAGE

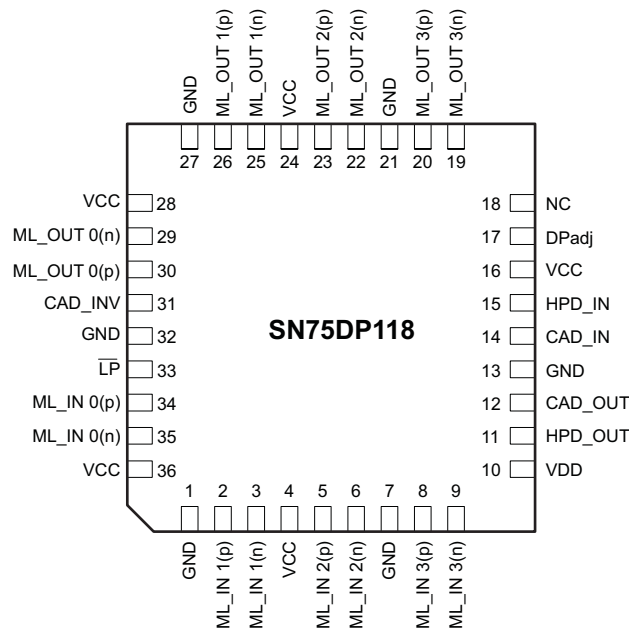

**PIN FUNCTIONS**

| PIN                              |                      | I/O | DESCRIPTION  |
|----------------------------------|----------------------|-----|--|
| SIGNAL                           | NO.                  |     |  |
| <b>MAIN LINK INPUT PINS</b>      |                      |     |  |
| ML_IN 0                          | 34, 35               | I   | DisplayPort Main Link Channel 0 Differential Input         |
| ML_IN 1                          | 2, 3                 | I   | DisplayPort Main Link Channel 1 Differential Input         |
| ML_IN 2                          | 5, 6                 | I   | DisplayPort Main Link Channel 2 Differential Input         |
| ML_IN 3                          | 8, 9                 | I   | DisplayPort Main Link Channel 3 Differential Input         |
| <b>MAIN LINK OUTPUT PINS</b>     |                      |     |  |
| ML_OUT 0                         | 30, 29               | O   | DisplayPort Main Link Port A Channel 0 Differential Output |
| ML_OUT 1                         | 26, 25               | O   | DisplayPort Main Link Port A Channel 1 Differential Output |
| ML_OUT 2                         | 23, 22               | O   | DisplayPort Main Link Port A Channel 2 Differential Output |
| ML_OUT 3                         | 20, 19               | O   | DisplayPort Main Link Port A Channel 3 Differential Output |
| <b>HOT PLUG DETECT PINS</b>      |                      |     |  |
| HPD_OUT                          | 11                   | O   | Hot Plug Detect Output to the DisplayPort Source           |
| HPD_IN                           | 15                   | I   | Hot Plug Detect Input from the DisplayPort Connector       |
| <b>CABLE ADAPTER DETECT PINS</b> |                      |     |  |
| CAD_OUT                          | 12                   | O   | Cable Adapter Detect Output to the DisplayPort Source      |
| CAD_IN                           | 14                   | I   | Cable Adapter Detect Input from the DisplayPort Connector  |
| <b>CONTROL PINS</b>              |                      |     |  |
| $\overline{\text{LP}}$           | 33                   | I   | Low Power Select Bar                                       |
| CAD_INV                          | 31                   | I   | Output Port Priority selection                             |
| DP <sub>adj</sub>                | 17                   | I   | DisplayPort Main Link Output Gain Adjustment               |
| NC                               | 16                   |     | Not Connected  |
| <b>SUPPLY AND GROUND PINS</b>    |                      |     |  |
| VCC                              | 4, 16, 24, 28, 36    |     | Primary Supply Voltage                                     |
| VDD                              | 10                   |     | HPD and CAD Output Voltage                                 |
| GND                              | 1, 7, 13, 21, 27, 32 |     | Ground   |

**Table 1. Control Pin Lookup**

| SIGNAL                 | LEVEL <sup>(1)</sup> | STATE            | DESCRIPTION  |
|------------------------|----------------------|------------------|--|
| $\overline{\text{LP}}$ | H                    | Normal Mode      | Normal operational mode for device   |
|                        | L                    | Low Power Mode   | Device is forced into a Low Power state causing the outputs to go to a high impedance state. All other inputs are ignored. |
| CAD_INV                | H                    | CAD Inverted     | The CAD output logic is inverted from the CAD input  |
|                        | L                    | CAD not Inverted | The CAD output logic follows the CAD input   |
| DP <sub>adj</sub>      | 4.53 k $\Omega$      | Increased Gain   | Main Link DisplayPort Output will have an increased voltage swing  |
|                        | 6.49 k $\Omega$      | Nominal Gain     | Main Link DisplayPort Output will have a nominal voltage swing   |
|                        | 10 k $\Omega$        | Decreased Gain   | Main Link DisplayPort Output will have a decreased voltage swing   |

(1) (H) Logic High; (L) Logic Low

### ORDERING INFORMATION

| PART NUMBER   | PART MARKING | PACKAGE <sup>(1)</sup>  |
|---------------|--------------|-------------------------|
| SN75DP118RHHR | DP118        | 36-pin QFN Reel (large) |
| SN75DP118RHHT | DP118        | 36-pin QFN Reel (small) |

(1) For the most current package and ordering information, see the Package Option Addendum at the end of this document, or see the TI website at [www.ti.com](http://www.ti.com).

### ABSOLUTE MAXIMUM RATINGS

over operating free-air temperature range (unless otherwise noted) <sup>(1)</sup>

|                                     |  | VALUE                         | UNIT |
|-------------------------------------|--|-------------------------------|------|
| Supply Voltage Range <sup>(2)</sup> | V <sub>CC</sub> , V <sub>DD</sub>                      | -0.3 to 5.5                   | V    |
| Voltage Range                       | Main Link I/O (ML_IN x, ML_OUT x) Differential Voltage | 1.5                           | V    |
|                                     | HPD and CAD I/O  | -0.3 to V <sub>CC</sub> + 0.3 | V    |
|                                     | Control I/O  | -0.3 to V <sub>CC</sub> + 0.3 | V    |
| Electrostatic discharge             | Human body model <sup>(3)</sup>                        | ±12000                        | V    |
|                                     | Charged-device model <sup>(4)</sup>                    | ±1000                         | V    |
|                                     | Machine model <sup>(5)</sup>                           | ±200                          | V    |
| Continuous power dissipation        |  | See Dissipation Rating Table  |      |

(1) Stresses beyond those listed under absolute maximum ratings may cause permanent damage to the device. These are stress ratings only and functional operation of the device at these or any conditions beyond those indicated under recommended operating conditions is not implied. Exposure to absolute-maximum-rated conditions for extended periods may affect device reliability.

(2) All voltage values, except differential voltages, are with respect to network ground terminal.

(3) Tested in accordance with JEDEC Standard 22, Test Method A114-B.

(4) Tested in accordance with JEDEC Standard 22, Test Method C101-A.

(5) Tested in accordance with JEDEC Standard 22, Test Method A115-A.

### DISSIPATION RATINGS

| PACKAGE          | PCB JEDEC STANDARD | T <sub>A</sub> < 25°C | DERATING FACTOR <sup>(1)</sup><br>ABOVE T <sub>A</sub> = 25°C | T <sub>A</sub> = 85°C<br>POWER RATING |
|------------------|--------------------|-----------------------|---|---------------------------------------|
| 36-pin QFN (RHH) | Low-K              | 759 mW                | 7.5 mW/°C   | 303 mW                                |
|                  | High-K             | 2127 mW               | 21.2 mW/°C  | 851 mW                                |

(1) This is the inverse of the junction-to-ambient thermal resistance when board-mounted and with no air flow.

### THERMAL CHARACTERISTICS

over operating free-air temperature range (unless otherwise noted)

| PARAMETER  | TEST CONDITIONS   | MIN | TYP   | MAX <sup>(1)</sup> | UNIT |
|--|---|-----|-------|--------------------|------|
| R <sub>θJB</sub> Junction-to-board thermal resistance    | 4x4 Thermal vias under powerpad   |     | 28.11 |                    | °C/W |
| R <sub>θJC</sub> Junction-to-case thermal resistance     |   |     | 32.77 |                    | °C/W |
| P <sub>D</sub> Device power dissipation                  | L <sub>P</sub> = 5.5 V; ML: V <sub>PP</sub> = 1200 mV, 2.7 Gbps, PRBS; HPD_IN/CAD_IN/CAD_INV = 5.5 V; V <sub>CC</sub> = 5.5 V, V <sub>DD</sub> = 5.25 V; Temp = 85°C; DP <sub>adj</sub> = 6.49 kΩ |     | 240   | 280                | mW   |
| P <sub>SD</sub> Device power dissipation under low power | L <sub>P</sub> = 0V; HPD_IN/CAD_IN/CAD_INV = 5.5V; V <sub>CC</sub> = 5.5V, V <sub>DD</sub> = 5.2 V; Temp = 85°C; DP <sub>adj</sub> = 6.49 kΩ  |     |       | 40                 | μW   |

(1) Maximum Rating is simulated under worse case condition.

## RECOMMENDED OPERATING CONDITIONS

over operating free-air temperature range (unless otherwise noted)

|                                    |   | MIN  | NOM | MAX  | UNIT     |
|------------------------------------|---|------|-----|------|----------|
| $V_{CC}$                           | Supply Voltage                          | 4.5  | 5   | 5.5  | V        |
| $V_{DD}$                           | HPD and CAD Output reference voltage    | 1.62 |     | 5.25 | V        |
| $T_A$                              | Operating free-air temperature          | 0    |     | 85   | °C       |
| <b>MAIN LINK DIFFERENTIAL PINS</b> |   |      |     |      |          |
| $V_{ID}$                           | Peak-to-peak input differential voltage | 0.15 |     | 1.40 | V        |
| $d_R$                              | Data rate                               |      |     | 2.7  | Gbps     |
| $R_t$                              | Termination resistance                  | 45   | 50  | 55   | $\Omega$ |
| $V_{O(term)}$                      | Output termination voltage              | 0    |     | 2    | V        |
| <b>HPD, CAD, AND CONTROL PINS</b>  |   |      |     |      |          |
| $V_{IH}$                           | High-level input voltage                | 2    |     | 5.5  | V        |
| $V_{IL}$                           | Low-level input Voltage                 | 0    |     | 0.8  | V        |

## DEVICE POWER

The SN75DP118 is designed to operate off of a single 5V supply.

## ELECTRICAL CHARACTERISTICS

over recommended operating conditions (unless otherwise noted)

| PARAMETER | TEST CONDITIONS   | MIN | TYP | MAX | UNIT    |
|-----------|---|-----|-----|-----|---------|
| $I_{CC}$  | Supply current<br>$\overline{LP} = 5.5$ V; ML: $V_{PP} = 1200$ mV, 2.7 Gbps, PRBS;<br>HPD_IN/CAD_IN/CAD_INV = 5.5 V;<br>$V_{CC} = 5.5$ V, $V_{DD} = 5.25$ V; Temp = 85°C;<br>$DP_{adj} = 6.49$ k $\Omega$ |     | 50  | 55  | mA      |
| $I_{DD}$  | Supply current<br>$V_{DD} = 5.5$ V  |     | 0.1 | 2   | mA      |
| $I_{SD}$  | Shutdown current<br>$\overline{LP} = 0$ V; HPD_IN/CAD_IN/CAD_INV = 5.5 V;<br>$V_{CC} = 5.5$ V, $V_{DD} = 5.25$ V;<br>Temp = 85°C; $DP_{adj} = 6.49$ k $\Omega$  |     | 4   | 10  | $\mu$ A |

## HOT PLUG AND CABLE ADAPTER DETECT

The SN75DP118 has a built in level shifter for the HPD and CAD outputs. The output voltage level of the HPD and CAD pins is defined by the voltage level of the VDD pin. The state of the HPD pin will also set the active state of the device. If HPD is low the device will enter low power mode. Once HPD goes high, the device will come out of low power mode and enter active mode. If HPD goes LOW for a period of time exceeding  $t_{T(HPD)}$ , the device will enter the low power mode.

## ELECTRICAL CHARACTERISTICS

over recommended operating (unless otherwise noted)

| PARAMETER   | TEST CONDITIONS           | MIN                                     | TYP | MAX | UNIT    |   |      |     |   |
|-------------|---------------------------|---|-----|-----|---------|---|------|-----|---|
| $V_{OH5}$   | High-level output voltage | $I_{OH} = -100$ $\mu$ A, $V_{DD} = 5$ V | 4.5 | 5   | V       |   |      |     |   |
| $V_{OH3.3}$ |                           |   |     |     |         | $I_{OH} = -100$ $\mu$ A, $V_{DD} = 3.3$ V | 3    | 3.3 | V |
| $V_{OH2.5}$ |                           |   |     |     |         | $I_{OH} = -100$ $\mu$ A, $V_{DD} = 2.5$ V | 2.25 | 2.5 | V |
| $V_{OH1.8}$ |                           |   |     |     |         | $I_{OH} = -100$ $\mu$ A, $V_{DD} = 1.8$ V | 1.62 | 1.8 | V |
| $V_{OL}$    | Low-level output voltage  | $I_{OH} = 100$ $\mu$ A                  | 0   | 0.4 | V       |   |      |     |   |
| $I_H$       | High-level input current  | $V_{IH} = 2$ V, $V_{CC} = 5.5$ V        | -10 | 10  | $\mu$ A |   |      |     |   |
| $I_L$       | Low-level input current   | $V_{IL} = 0.8$ V, $V_{CC} = 5.5$ V      | -10 | 10  | $\mu$ A |   |      |     |   |

### SWITCHING CHARACTERISTICS

over recommended operating (unless otherwise noted)

| PARAMETER     |   | TEST CONDITIONS       | MIN | TYP | MAX | UNIT |
|---------------|---|-----------------------|-----|-----|-----|------|
| $t_{PD(CAD)}$ | Propagation delay                         | $V_{DD} = 5\text{ V}$ |     | 20  | 30  | ns   |
| $t_{PD(HPD)}$ | Propagation delay                         | $V_{DD} = 5\text{ V}$ |     | 70  | 110 | ns   |
| $t_{T(HPD)}$  | HPD logic switch time                     | $V_{DD} = 5\text{ V}$ | 200 |     | 400 | ms   |
| $t_{M(HPD)}$  | Minimum output pulse duration             | $V_{DD} = 5\text{ V}$ | 100 |     |     | ns   |
| $t_{Z(HPD)}$  | Low power to high-level propagation delay | $V_{DD} = 5\text{ V}$ |     | 70  | 110 | ns   |

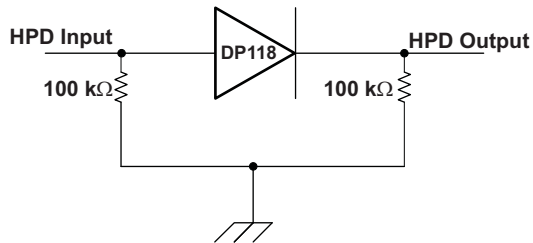

Figure 1. HPD Test Circuit

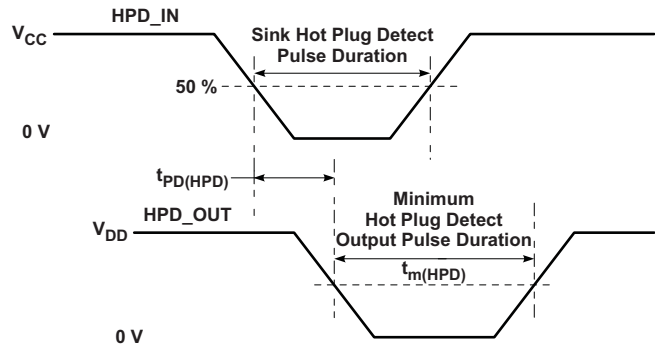

Figure 2. HPD Timing Diagram #1

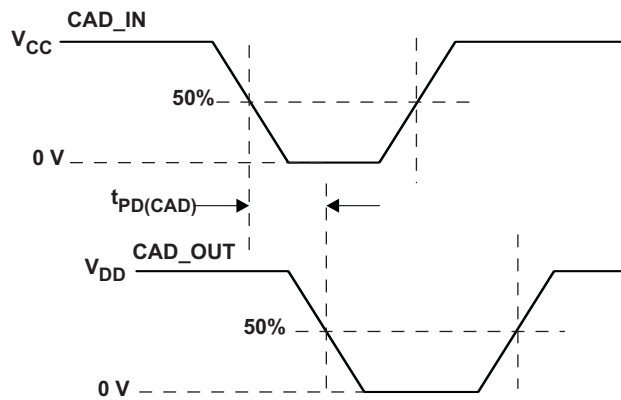

Figure 3. CAD Timing Diagram

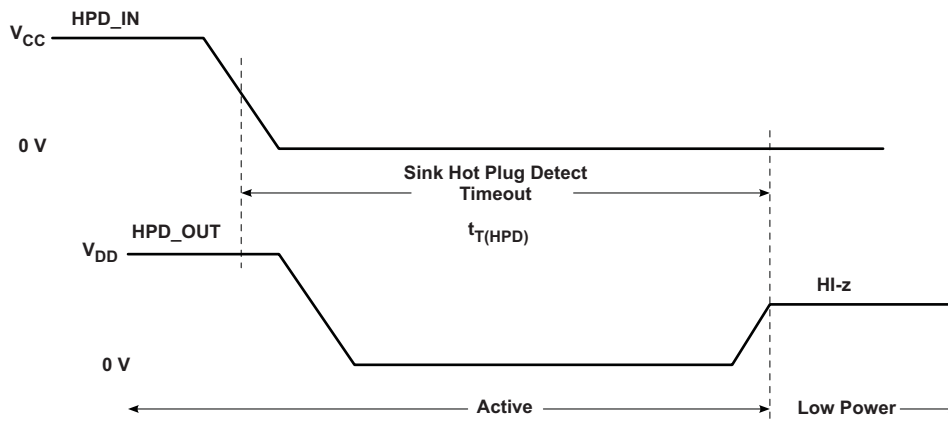

Figure 4. HPD Timing Diagram Number 2

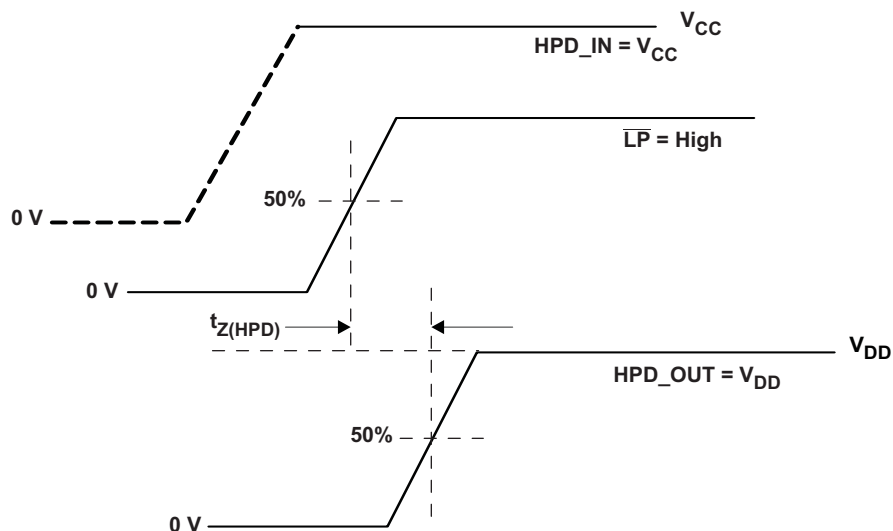

Figure 5. HPD Timing Diagram Number 3

### MAIN LINK PINS

The main link I/O of the SN75DP118 is designed to track the magnitude and frequency characteristics of the input waveform and replicate them on the output. A feature has also been incorporated in the SN75DP118 to either increase or decrease the output amplitude via the resistor connected between the DP<sub>adj</sub> pin and ground.

### ELECTRICAL CHARACTERISTICS

over recommended operating (unless otherwise noted)

| PARAMETER           |  | TEST CONDITIONS  | MIN | TYP | MAX | UNIT     |
|---------------------|--|--|-----|-----|-----|----------|
| $\Delta V_{I/O(2)}$ | Difference between input and output voltages ( $V_{OD} - V_{ID}$ ) | $V_{ID} = 200 \text{ mV}$ , $DP_{adj} = 6.5 \text{ k}\Omega$ | 0   | 30  | 60  | mV       |
| $\Delta V_{I/O(3)}$ |  | $V_{ID} = 300 \text{ mV}$ , $DP_{adj} = 6.5 \text{ k}\Omega$ | -24 | 11  | 36  |          |
| $\Delta V_{I/O(4)}$ |  | $V_{ID} = 400 \text{ mV}$ , $DP_{adj} = 6.5 \text{ k}\Omega$ | -45 | -15 | 15  |          |
| $\Delta V_{I/O(6)}$ |  | $V_{ID} = 600 \text{ mV}$ , $DP_{adj} = 6.5 \text{ k}\Omega$ | -87 | -47 | -22 |          |
| $R_{INT}$           | Input termination impedance  |  | 45  | 50  | 55  | $\Omega$ |
| $V_{Iterm}$         | Input termination voltage  |  | 0   |     | 2   | V        |

### SWITCHING CHARACTERISTICS

over recommended operating (unless otherwise noted)

| PARAMETER       |                                     | TEST CONDITIONS   | MIN | TYP | MAX | UNIT |
|-----------------|-------------------------------------|---|-----|-----|-----|------|
| $t_{R/F(DP)}$   | Output edge rate (20% - 80%)        | Input edge rate = 80 ps (20% - 80%)                       |     | 115 |     | ps   |
| $t_{PD}$        | Propagation delay time              | $F = 1\text{MHz}$ , $V_{ID} = 400 \text{ mV}$             | 200 | 240 | 280 | ps   |
| $t_{SK(1)}$     | Intra-pair skew                     | $F = 1\text{MHz}$ , $V_{ID} = 400 \text{ mV}$             |     |     | 20  | ps   |
| $t_{SK(2)}$     | Inter-pair skew                     | $F = 1\text{MHz}$ , $V_{ID} = 400 \text{ mV}$             |     |     | 40  | ps   |
| $t_{DPJIT(PP)}$ | Peak-to-peak output residual jitter | $dR = 2.7\text{Gbps}$ , $V_{ID} = 400 \text{ mV}$ , PRBS7 |     | 25  | 35  | ps   |



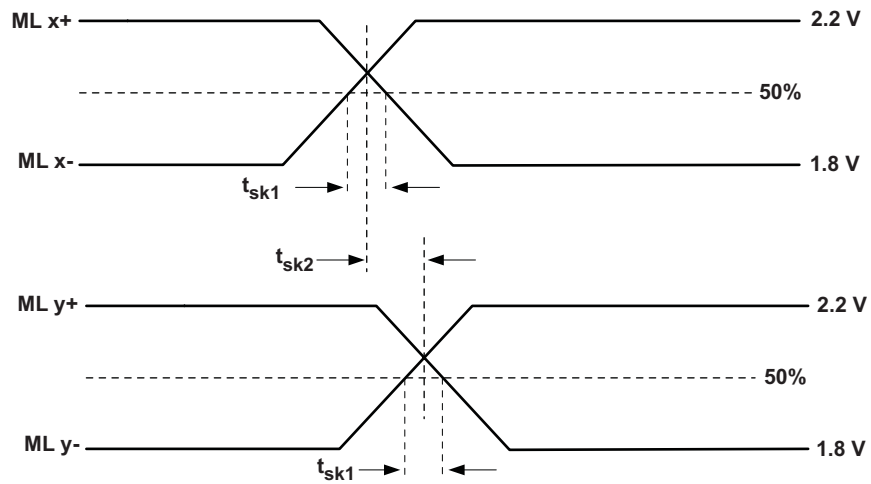

Figure 9. Main Link Skew Measurements

TYPICAL CHARACTERISTICS

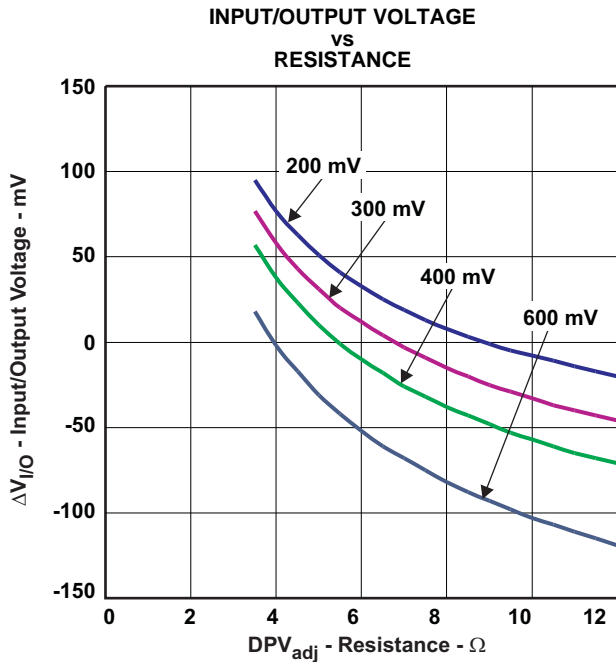

Figure 10.

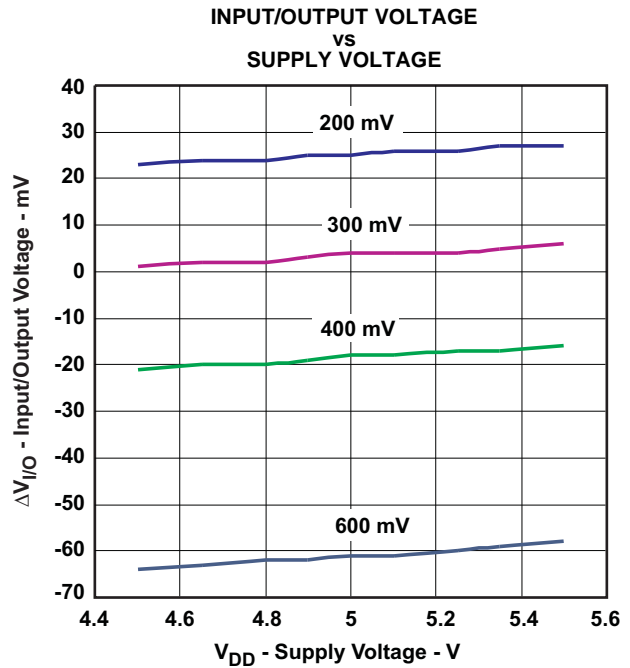

Figure 11.

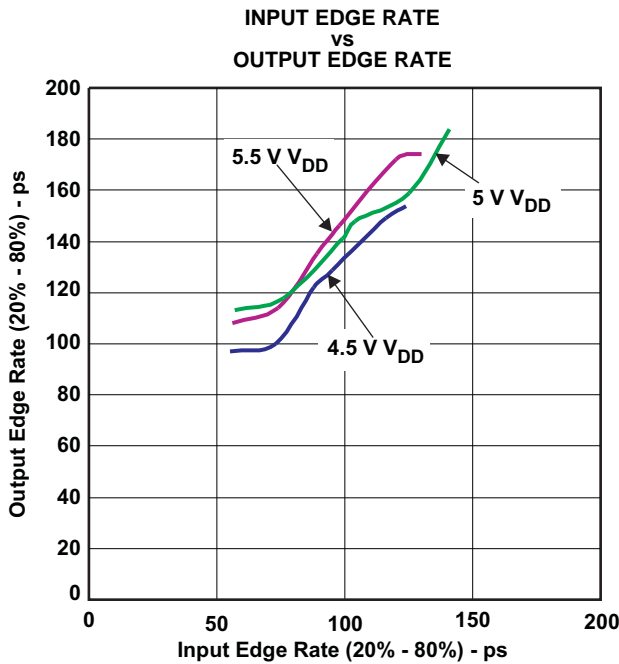

Figure 12.

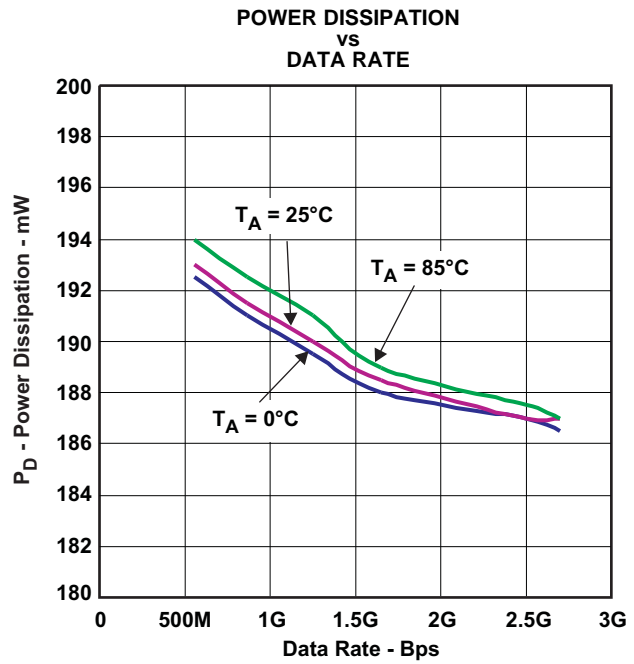

Figure 13.

## APPLICATION INFORMATION

### Power Logic

The power logic of the SN75DP118 is tied to the state of the HPD input pin as well as the low power pin. When HPD\_IN is LOW the SN75DP118 enters the low power state. In this state the outputs are high impedance and the device shuts down to optimize power conservation. When HPD\_IN goes high the device enters the normal operational state.

Several key factors were taken into consideration with this digital logic implementation of channel selection, as well as HPD repeating. This logic is described in the following scenarios.

Scenario 1. Low Power State to Active State:

- There are two possible cases for this scenario depending on the state of the low power pin.
  - Case one: In this case HPD\_IN is initially LOW and the low power pin is also LOW. In this initial state the device is in a low power mode. Once the HPD input goes to a HIGH state the device remains in the low power mode, with both the main link and auxiliary I/O in a high impedance state (Figure 14).
  - Case two: In this case HPD\_IN is initially LOW and the low power pin is HIGH. In this initial state the device is in a low power mode. Once the HPD input goes to a HIGH state the device comes out of the low power mode and enters active mode, enabling the main link and auxiliary I/O. The HPD output to the source is enabled and follows the logic state of the input HPD (Figure 15). This is specified as  $t_{Z(HPD)}$ .

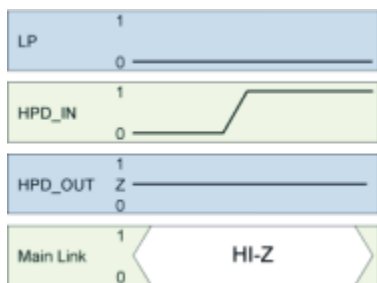

Figure 14.

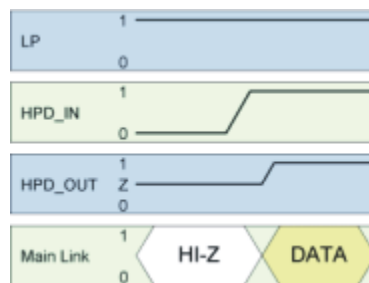

Figure 15.

Scenario 2. HPD Changes:

- In this case the HPD input is initially HIGH. The HPD output logic state follows the state of the HPD input. If the HPD input pulses LOW, as may be the case if the sink device is requesting an interrupt, the HPD output to the source will also pulse Low for the same duration of time with a slight delay (Figure 16). The delay of this signal through the SN75DP118 is specified as  $t_{PD(HPD)}$ . If the duration of the LOW pulse is less than  $t_{M(HPD)}$  it may not be accurately repeated to the source. If the duration of the LOW pulse exceeds  $t_{T(HPD)}$  the device determines that an unplug event has occurred and enters the low power state (Figure 17). Once the HPD input goes high again the device returns to the active state as indicated in scenario 1.

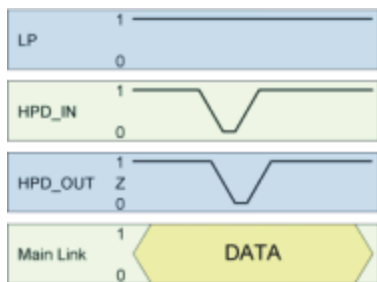

Figure 16.

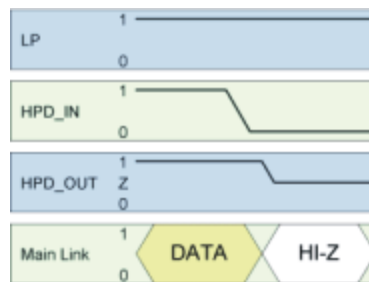

Figure 17.

**PACKAGING INFORMATION**

| Orderable Device | Status<br>(1) | Package Type | Package Drawing | Pins | Package Qty | Eco Plan<br>(2)         | Lead/Ball Finish<br>(6) | MSL Peak Temp<br>(3) | Op Temp (°C) | Device Marking<br>(4/5) | Samples                 |
|------------------|---------------|--------------|-----------------|------|-------------|-------------------------|-------------------------|----------------------|--------------|-------------------------|-------------------------|
| SN75DP118RHHR    | ACTIVE        | VQFN         | RHH             | 36   | 2500        | Green (RoHS & no Sb/Br) | CU NIPDAU               | Level-3-260C-168 HR  | 0 to 85      | DP118                   | <a href="#">Samples</a> |
| SN75DP118RHHT    | ACTIVE        | VQFN         | RHH             | 36   | 250         | Green (RoHS & no Sb/Br) | CU NIPDAU               | Level-3-260C-168 HR  | 0 to 85      | DP118                   | <a href="#">Samples</a> |

(1) The marketing status values are defined as follows:

**ACTIVE:** Product device recommended for new designs.

**LIFEBUY:** TI has announced that the device will be discontinued, and a lifetime-buy period is in effect.

**NRND:** Not recommended for new designs. Device is in production to support existing customers, but TI does not recommend using this part in a new design.

**PREVIEW:** Device has been announced but is not in production. Samples may or may not be available.

**OBSOLETE:** TI has discontinued the production of the device.

(2) Eco Plan - The planned eco-friendly classification: Pb-Free (RoHS), Pb-Free (RoHS Exempt), or Green (RoHS & no Sb/Br) - please check <http://www.ti.com/productcontent> for the latest availability information and additional product content details.

**TBD:** The Pb-Free/Green conversion plan has not been defined.

**Pb-Free (RoHS):** TI's terms "Lead-Free" or "Pb-Free" mean semiconductor products that are compatible with the current RoHS requirements for all 6 substances, including the requirement that lead not exceed 0.1% by weight in homogeneous materials. Where designed to be soldered at high temperatures, TI Pb-Free products are suitable for use in specified lead-free processes.

**Pb-Free (RoHS Exempt):** This component has a RoHS exemption for either 1) lead-based flip-chip solder bumps used between the die and package, or 2) lead-based die adhesive used between the die and leadframe. The component is otherwise considered Pb-Free (RoHS compatible) as defined above.

**Green (RoHS & no Sb/Br):** TI defines "Green" to mean Pb-Free (RoHS compatible), and free of Bromine (Br) and Antimony (Sb) based flame retardants (Br or Sb do not exceed 0.1% by weight in homogeneous material)

(3) MSL, Peak Temp. - The Moisture Sensitivity Level rating according to the JEDEC industry standard classifications, and peak solder temperature.

(4) There may be additional marking, which relates to the logo, the lot trace code information, or the environmental category on the device.

(5) Multiple Device Markings will be inside parentheses. Only one Device Marking contained in parentheses and separated by a "~" will appear on a device. If a line is indented then it is a continuation of the previous line and the two combined represent the entire Device Marking for that device.

(6) Lead/Ball Finish - Orderable Devices may have multiple material finish options. Finish options are separated by a vertical ruled line. Lead/Ball Finish values may wrap to two lines if the finish value exceeds the maximum column width.

**Important Information and Disclaimer:** The information provided on this page represents TI's knowledge and belief as of the date that it is provided. TI bases its knowledge and belief on information provided by third parties, and makes no representation or warranty as to the accuracy of such information. Efforts are underway to better integrate information from third parties. TI has taken and continues to take reasonable steps to provide representative and accurate information but may not have conducted destructive testing or chemical analysis on incoming materials and chemicals. TI and TI suppliers consider certain information to be proprietary, and thus CAS numbers and other limited information may not be available for release.

In no event shall TI's liability arising out of such information exceed the total purchase price of the TI part(s) at issue in this document sold by TI to Customer on an annual basis.

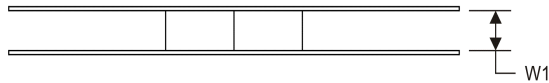
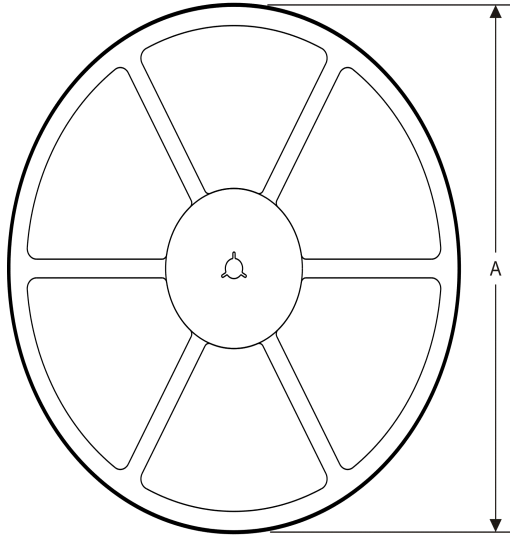
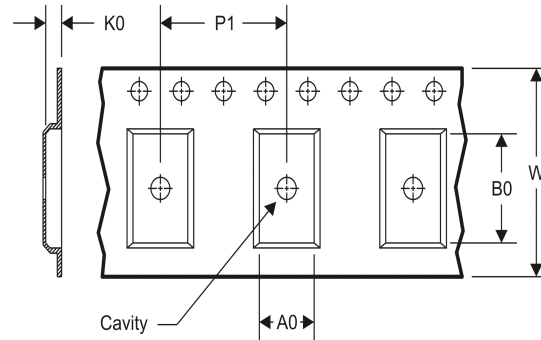
**TAPE AND REEL INFORMATION**
**REEL DIMENSIONS**

**TAPE DIMENSIONS**

|    |   |
|----|---|
| A0 | Dimension designed to accommodate the component width     |
| B0 | Dimension designed to accommodate the component length    |
| K0 | Dimension designed to accommodate the component thickness |
| W  | Overall width of the carrier tape                         |
| P1 | Pitch between successive cavity centers                   |

**TAPE AND REEL INFORMATION**

\*All dimensions are nominal

| Device        | Package Type | Package Drawing | Pins | SPQ  | Reel Diameter (mm) | Reel Width W1 (mm) | A0 (mm) | B0 (mm) | K0 (mm) | P1 (mm) | W (mm) | Pin1 Quadrant |
|---------------|--------------|-----------------|------|------|--------------------|--------------------|---------|---------|---------|---------|--------|---------------|
| SN75DP118RHHR | VQFN         | RHH             | 36   | 2500 | 330.0              | 16.4               | 6.3     | 6.3     | 1.1     | 12.0    | 16.0   | Q2            |
| SN75DP118RHHT | VQFN         | RHH             | 36   | 250  | 180.0              | 16.4               | 6.3     | 6.3     | 1.1     | 12.0    | 16.0   | Q2            |

**TAPE AND REEL BOX DIMENSIONS**



\*All dimensions are nominal

| Device        | Package Type | Package Drawing | Pins | SPQ  | Length (mm) | Width (mm) | Height (mm) |
|---------------|--------------|-----------------|------|------|-------------|------------|-------------|
| SN75DP118RHHR | VQFN         | RHH             | 36   | 2500 | 367.0       | 367.0      | 38.0        |
| SN75DP118RHHT | VQFN         | RHH             | 36   | 250  | 210.0       | 185.0      | 35.0        |

# MECHANICAL DATA

RHH (S-PVQFN-N36)

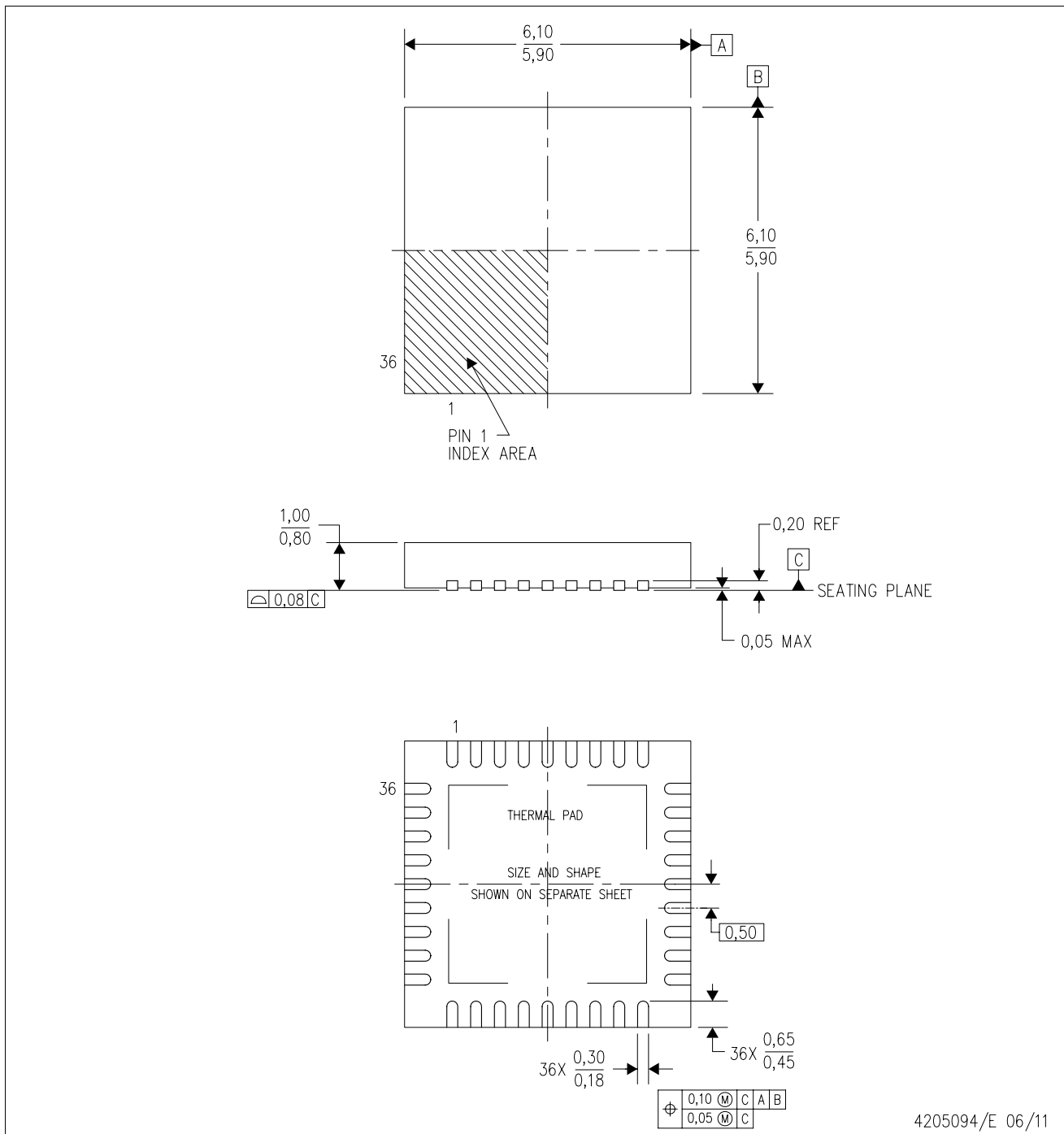
PLASTIC QUAD FLATPACK NO-LEAD



- NOTES:
- A. All linear dimensions are in millimeters. Dimensioning and tolerancing per ASME Y14.5M-1994.
  - B. This drawing is subject to change without notice.
  - C. QFN (Quad Flatpack No-Lead) Package configuration.
  - D. The package thermal pad must be soldered to the board for thermal and mechanical performance.
  - E. See the additional figure in the Product Data Sheet for details regarding the exposed thermal pad features and dimensions.
  - F. Falls within JEDEC MO-220.

# THERMAL PAD MECHANICAL DATA

RHH (S-PVQFN-N36)

PLASTIC QUAD FLATPACK NO-LEAD

## THERMAL INFORMATION

This package incorporates an exposed thermal pad that is designed to be attached directly to an external heatsink. The thermal pad must be soldered directly to the printed circuit board (PCB). After soldering, the PCB can be used as a heatsink. In addition, through the use of thermal vias, the thermal pad can be attached directly to the appropriate copper plane shown in the electrical schematic for the device, or alternatively, can be attached to a special heatsink structure designed into the PCB. This design optimizes the heat transfer from the integrated circuit (IC).

For information on the Quad Flatpack No-Lead (QFN) package and its advantages, refer to Application Report, QFN/SON PCB Attachment, Texas Instruments Literature No. SLUA271. This document is available at [www.ti.com](http://www.ti.com).

The exposed thermal pad dimensions for this package are shown in the following illustration.

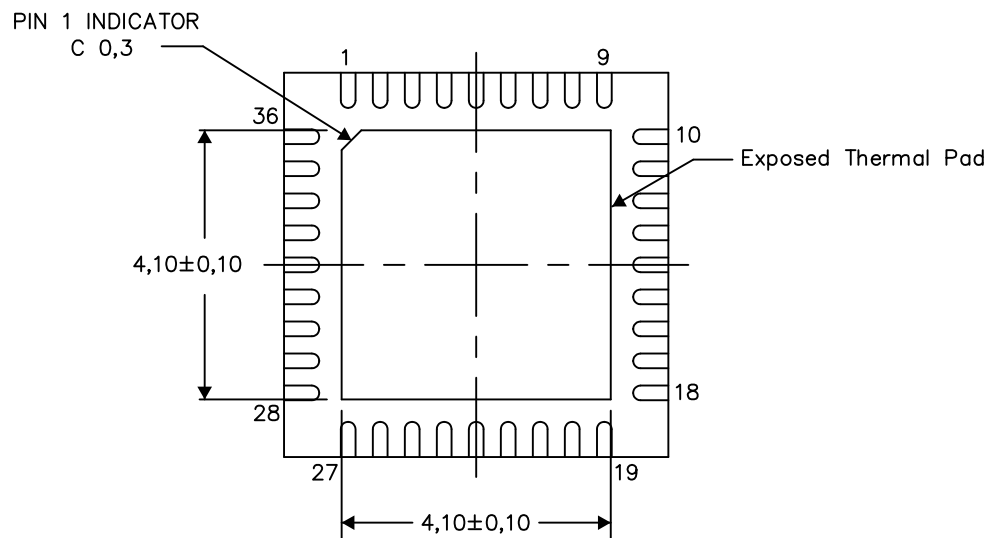

Bottom View

Exposed Thermal Pad Dimensions

4206362-3/M 11/13

NOTE: All linear dimensions are in millimeters

RHH (S-PQFP-N36)

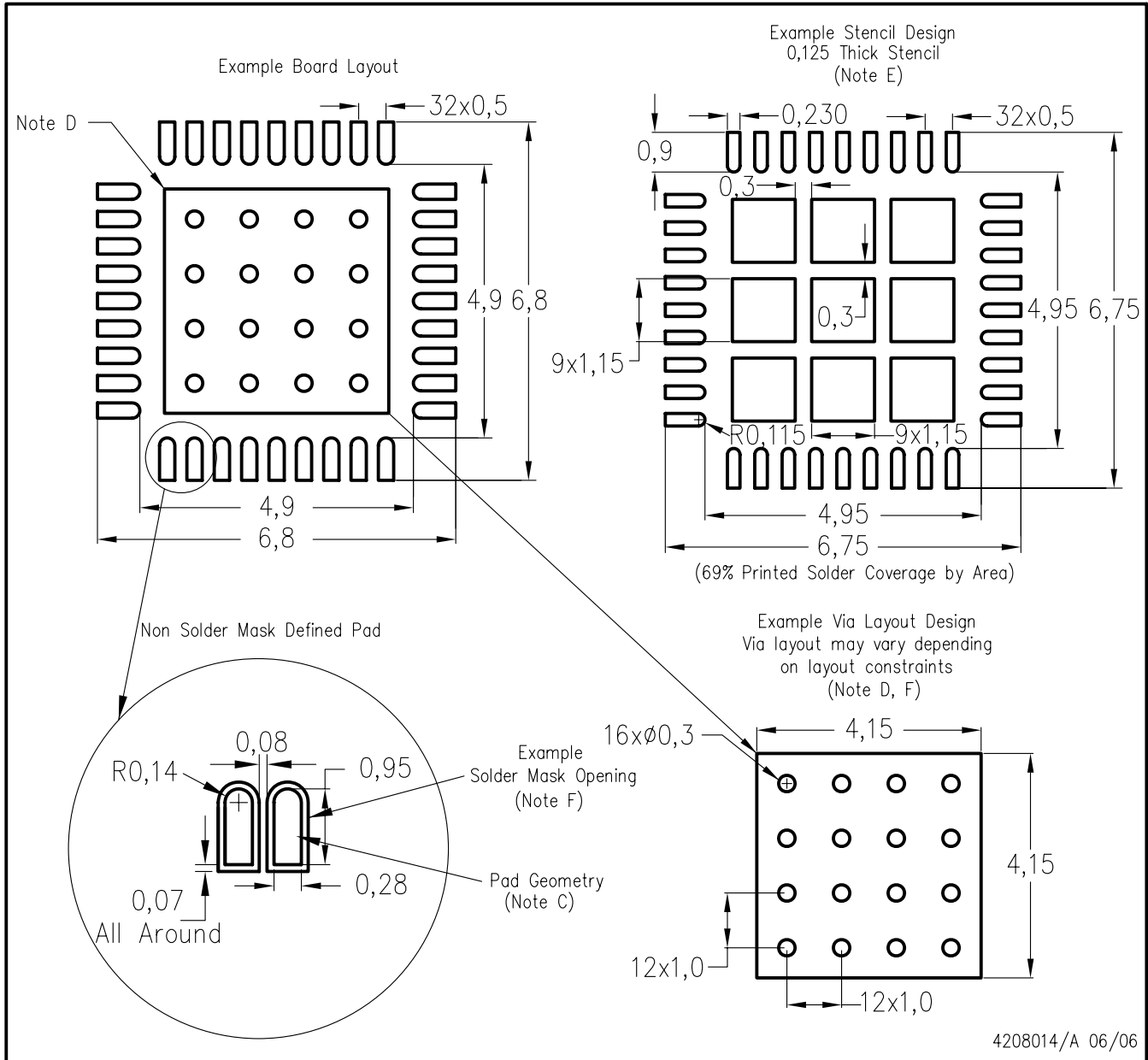

- NOTES:
- All linear dimensions are in millimeters.
  - This drawing is subject to change without notice.
  - Publication IPC-7351 is recommended for alternate designs.
  - This package is designed to be soldered to a thermal pad on the board. Refer to Application Note, Quad Flat-Pack Packages, Texas Instruments Literature No. SCBA017, SLUA271, and also the Product Data Sheets for specific thermal information, via requirements, and recommended board layout. These documents are available at [www.ti.com](http://www.ti.com) <<http://www.ti.com>>.
  - Laser cutting apertures with trapezoidal walls and also rounding corners will offer better paste release. Customers should contact their board assembly site for stencil design recommendations. Refer to IPC 7525 for stencil design considerations.
  - Customers should contact their board fabrication site for recommended solder mask tolerances and via tenting recommendations for vias placed in the thermal pad.

## IMPORTANT NOTICE

Texas Instruments Incorporated and its subsidiaries (TI) reserve the right to make corrections, enhancements, improvements and other changes to its semiconductor products and services per JESD46, latest issue, and to discontinue any product or service per JESD48, latest issue. Buyers should obtain the latest relevant information before placing orders and should verify that such information is current and complete. All semiconductor products (also referred to herein as "components") are sold subject to TI's terms and conditions of sale supplied at the time of order acknowledgment.

TI warrants performance of its components to the specifications applicable at the time of sale, in accordance with the warranty in TI's terms and conditions of sale of semiconductor products. Testing and other quality control techniques are used to the extent TI deems necessary to support this warranty. Except where mandated by applicable law, testing of all parameters of each component is not necessarily performed.

TI assumes no liability for applications assistance or the design of Buyers' products. Buyers are responsible for their products and applications using TI components. To minimize the risks associated with Buyers' products and applications, Buyers should provide adequate design and operating safeguards.

TI does not warrant or represent that any license, either express or implied, is granted under any patent right, copyright, mask work right, or other intellectual property right relating to any combination, machine, or process in which TI components or services are used. Information published by TI regarding third-party products or services does not constitute a license to use such products or services or a warranty or endorsement thereof. Use of such information may require a license from a third party under the patents or other intellectual property of the third party, or a license from TI under the patents or other intellectual property of TI.

Reproduction of significant portions of TI information in TI data books or data sheets is permissible only if reproduction is without alteration and is accompanied by all associated warranties, conditions, limitations, and notices. TI is not responsible or liable for such altered documentation. Information of third parties may be subject to additional restrictions.

Resale of TI components or services with statements different from or beyond the parameters stated by TI for that component or service voids all express and any implied warranties for the associated TI component or service and is an unfair and deceptive business practice. TI is not responsible or liable for any such statements.

Buyer acknowledges and agrees that it is solely responsible for compliance with all legal, regulatory and safety-related requirements concerning its products, and any use of TI components in its applications, notwithstanding any applications-related information or support that may be provided by TI. Buyer represents and agrees that it has all the necessary expertise to create and implement safeguards which anticipate dangerous consequences of failures, monitor failures and their consequences, lessen the likelihood of failures that might cause harm and take appropriate remedial actions. Buyer will fully indemnify TI and its representatives against any damages arising out of the use of any TI components in safety-critical applications.

In some cases, TI components may be promoted specifically to facilitate safety-related applications. With such components, TI's goal is to help enable customers to design and create their own end-product solutions that meet applicable functional safety standards and requirements. Nonetheless, such components are subject to these terms.

No TI components are authorized for use in FDA Class III (or similar life-critical medical equipment) unless authorized officers of the parties have executed a special agreement specifically governing such use.

Only those TI components which TI has specifically designated as military grade or "enhanced plastic" are designed and intended for use in military/aerospace applications or environments. Buyer acknowledges and agrees that any military or aerospace use of TI components which have **not** been so designated is solely at the Buyer's risk, and that Buyer is solely responsible for compliance with all legal and regulatory requirements in connection with such use.

TI has specifically designated certain components as meeting ISO/TS16949 requirements, mainly for automotive use. In any case of use of non-designated products, TI will not be responsible for any failure to meet ISO/TS16949.

### Products

|                              |  |
|------------------------------|--|
| Audio                        | <a href="http://www.ti.com/audio">www.ti.com/audio</a>                               |
| Amplifiers                   | <a href="http://amplifier.ti.com">amplifier.ti.com</a>                               |
| Data Converters              | <a href="http://dataconverter.ti.com">dataconverter.ti.com</a>                       |
| DLP® Products                | <a href="http://www.dlp.com">www.dlp.com</a>   |
| DSP                          | <a href="http://dsp.ti.com">dsp.ti.com</a>   |
| Clocks and Timers            | <a href="http://www.ti.com/clocks">www.ti.com/clocks</a>                             |
| Interface                    | <a href="http://interface.ti.com">interface.ti.com</a>                               |
| Logic                        | <a href="http://logic.ti.com">logic.ti.com</a>                                       |
| Power Mgmt                   | <a href="http://power.ti.com">power.ti.com</a>                                       |
| Microcontrollers             | <a href="http://microcontroller.ti.com">microcontroller.ti.com</a>                   |
| RFID                         | <a href="http://www.ti-rfid.com">www.ti-rfid.com</a>                                 |
| OMAP Applications Processors | <a href="http://www.ti.com/omap">www.ti.com/omap</a>                                 |
| Wireless Connectivity        | <a href="http://www.ti.com/wirelessconnectivity">www.ti.com/wirelessconnectivity</a> |

### Applications

|                               |  |
|-------------------------------|--|
| Automotive and Transportation | <a href="http://www.ti.com/automotive">www.ti.com/automotive</a>                         |
| Communications and Telecom    | <a href="http://www.ti.com/communications">www.ti.com/communications</a>                 |
| Computers and Peripherals     | <a href="http://www.ti.com/computers">www.ti.com/computers</a>                           |
| Consumer Electronics          | <a href="http://www.ti.com/consumer-apps">www.ti.com/consumer-apps</a>                   |
| Energy and Lighting           | <a href="http://www.ti.com/energy">www.ti.com/energy</a>                                 |
| Industrial                    | <a href="http://www.ti.com/industrial">www.ti.com/industrial</a>                         |
| Medical                       | <a href="http://www.ti.com/medical">www.ti.com/medical</a>                               |
| Security                      | <a href="http://www.ti.com/security">www.ti.com/security</a>                             |
| Space, Avionics and Defense   | <a href="http://www.ti.com/space-avionics-defense">www.ti.com/space-avionics-defense</a> |
| Video and Imaging             | <a href="http://www.ti.com/video">www.ti.com/video</a>                                   |

### TI E2E Community

[e2e.ti.com](http://e2e.ti.com)

## Looking for pricing, stock, or lifecycle information?

Click below to explore more details on WIN SOURCE:

 [View SN75DP118RHHR on WIN SOURCE](#)

 [Texas Instruments](#) Information

## Optimize Your Supply Chain with WIN SOURCE Solutions

-  Global Sourcing Solution
-  Obsolete Management
-  Cost Control Management
-  Shortage Management
-  Alternative Solution
-  Excess Inventory Management