



THE DATASHEET OF TSB43DB42GHC



IEEE 1394a-2000 CONSUMER ELECTRONICS SOLUTION

FEATURES

- **1394 Features**
 - Integrated 400/200/100 Mbps 2-Port PHY
 - Compliant to IEEE 1394-1995 and IEEE 1394a-2000 Standards
 - Supports Bus Manager Functions and Automatic 1394 Self-ID Verification
 - Separate Asynchronous Ack FIFOs Decrease the Ack-Tracking Burden on External CPU
- **DTLA Encryption Support for MPEG2-DVB, DSS, and Audio Data (TSB43DA42 Only)**
 - Support for up to Three Encrypted/Decrypted Streams at One Time
 - Full Ake Performed With Hardware Assist
 - Secure Method for Loading DTLA Information Using Ex-CPU Interface
- **Audio and Video Interfaces**
 - Three Configurable High-Speed Data Ports for Video Data
 - Two Ports Configurable as Parallel or Serial
 - One Port Serial Only
 - Two Interfaces for Audio Data (Only One Audio Stream Supported at a Time)
 - 60958 Port
 - I2S-Style DAC Interface for PCM Data (Two Channel)
 - Pass-Through Modes for HSDI0 and HSDI1
 - Packet Insertion – Two Insertion Buffers per HSDI
 - PID Filtering (32 PID Filters per HSDI Port)
- **External CPU Interfaces**
 - Motorola 68K-Style 16-Bit Asynchronous Interface (Supports External DMA Only)
 - SRAM-Like 16-Bit Asynchronous Interface (Supports External DMA Only)
 - PCI Interface (33 MHz) Compliant to PCI Specification Version 2.2 (Supports PCI Slave and Master Function)
- **Data Buffers**
 - 3x 4K Byte Isochronous Buffers for Audio and Video Data
 - 2x 2K Byte Asynchronous/Asynchronous Stream Transmit Buffers
 - 2x 2K Byte Asynchronous/Asynchronous Stream Receive Buffers
 - 1x 1K Byte Self-ID Buffer
 - Insertion Buffers for MPEG2 Packet Insertion (DAT, PMT, SIT, and DIT)
 - Programmable Data/Space Available Indicators for Buffer Flow Control
- **Hardware Packet Formatting for the Following Standards**
 - IEC61883-1 (General)
 - IEC61883-2 (SD-DVCR)
 - IEC61883-4 (MPEG2-TS)
 - IEC61883-6 (Audio and Music)
 - IEC61883-7 (ITU-R BO.1294 System B) – DSS
 - Asynchronous Packets
 - Asynchronous Streams
 - PHY Packets (Including Self-IDs)
- **Additional Features**
 - JTAG Interface to Support Post-Assembly Scan of Device I/O – Boundary Scan
 - Unique Binding Method for Protecting Sensitive Off-Chip Data From Ex-CPU Interface



Please be aware that an important notice concerning availability, standard warranty, and use in critical applications of Texas Instruments semiconductor products and disclaimers thereto appears at the end of this data sheet.

DESCRIPTION/ORDERING INFORMATION

The TSB43DA42/TSB43DB42 are high-performance consumer electronics 1394 link layer and integrated physical layer devices designed for digitally interfacing advanced audio/video consumer electronics applications. TSB43DA42/DB42 support formatting and transmission of IEC61883 data; including IEC61883-1 (general), IEC61883-2 (SD-DVCR), IEC61883-4 (MPEG2-TS), IEC61883-5 (SDL-DVCR), IEC61883-6 (audio and music), and IEC61883-7 (ITU-R BO.1294 SystemB-DSS). TSB43DA42/DB42 also supports standard 1394 data types, such as asynchronous, asynchronous streams, and PHY packets.

The TSB43DA42 version incorporates M6 baseline per the 5C specification to support transmit and receive of up to three MPEG2 or audio formatted transport streams with encryption and decryption. The TSB43DA42 version also includes hardware acceleration for content key generation.

The TSB43DB42 version is identical to the TSB43DA42 without implementation of the encryption/decryption features. The TSB43DB42 device allows customers that do not require the encryption/decryption features to incorporate the TSB43DA42 function without becoming DTLA licensees.

The TSB43DA42/TSB43DB42 feature an integrated two-port PHY. The PHY operates at 100 Mbps, 200 Mbps, or 400 Mbps. They follow all requirements as stated in the IEEE 1394-1995 and IEEE 1394a-2000 standards.

ORDERING INFORMATION

T _A	PACKAGE		ORDERABLE PART NUMBER	TOP-SIDE MARKING
–20°C to 85°C	BGA – GHC	Reel of 126	TSB43DA42AGHC	TSB43DA42A
		Reel of 1000	TSB43DA42AGHCR	
		Reel of 126	TSB43DA42GHC	TSB43DA42
		Reel of 1000	TSB43DA42GHCR	
	BGA – ZHC	Reel of 126	TSB43DA42AZHC	TSB43DA42A
		Reel of 1000	TSB43DA42AZHCR	
	LQFP – PGF	Tube of 36	TSB43DA42PGF	PREVIEW
	PQFP – PDV	Tube of 40	TSB43DA42PDV	PREVIEW

APPLICATION INFORMATION

HDTV Application

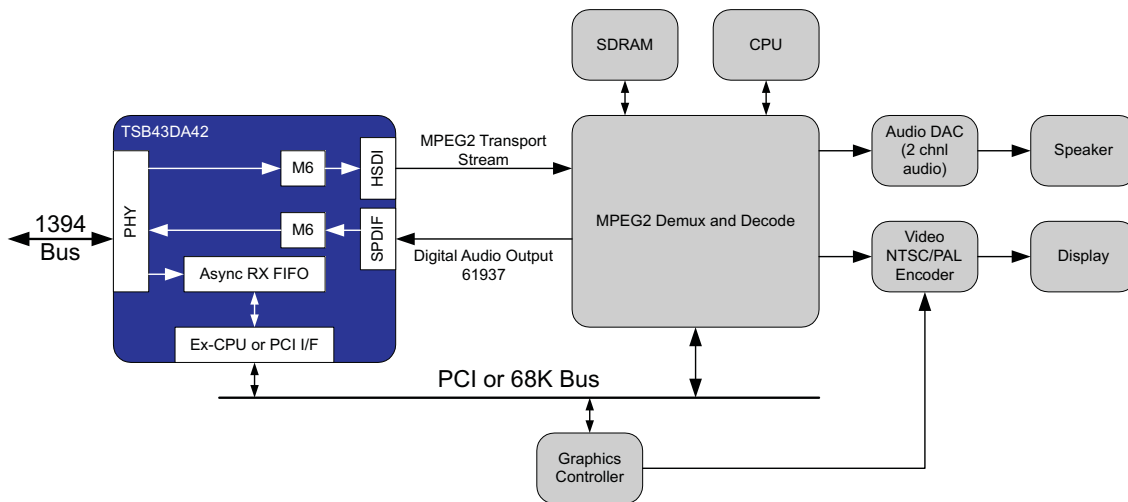

Figure 1. TSB43DA42 in HDTV Application

In the HDTV application, the TSB43DA42 receives the MPEG2 transport stream, decrypts it using the M6 cipher, and outputs it to the application over the HSDI port. The MPEG2 demux and decode device separates the audio and video streams, decodes them, and outputs the 2-channel audio to an audio DAC for listening and video to an NTSC/PAL encoder for display.

The HDTV receives on-screen display (OSD) information from the video source, such as a set top box, using the EIA775 standard. The system processor receives the OSD data through the TSB43DA42 asynchronous receive buffer. The system graphics controller controls the OSD and mixes it with the video data for display.

The MPEG2 demux device also outputs the encoded audio in SPDIF format using the IEC61937 standard. This stream is input to the TSB43DA42 using the SPDIF input port. The TSB43DA42 encrypts the stream using the M6 cipher (if necessary) and transmits it over 1394 to an AV/R or other audio device.

APPLICATION INFORMATION (continued)

STB Application

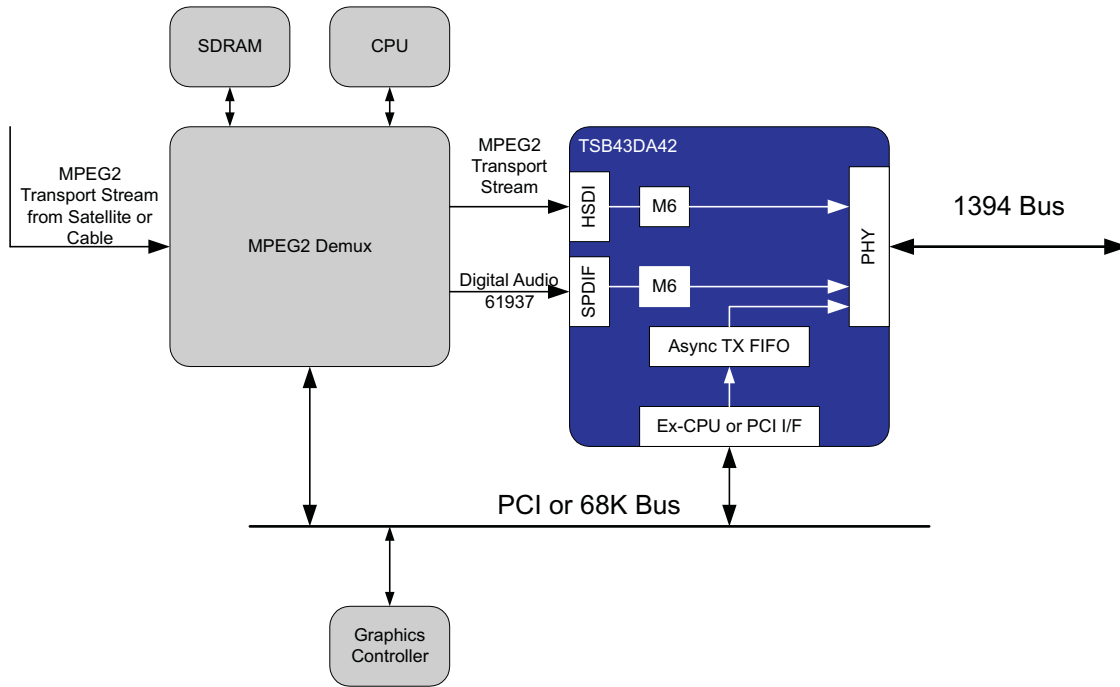

Figure 2. TSB43DA42 in STB Application

The set top box receives the MPEG2 transport stream from either satellite or cable sources. The MPEG2 demux device splits the audio and video portion of the MPEG2 transport stream. The video portion, including 2-channel audio, is input to the TSB43DA42 HSDI port. The TSB43DA42 performs any PID filtering or packet insertion, encrypts the stream using M6 cipher, and transmits the stream over 1394.

The audio portion of the transport stream is packed into SPDIF format by the MPEG2 demux device using the IEC61937 standard. The audio stream is input to the TSB43DA42 audio port, encrypted using M6 cipher if necessary, and transmitted over 1394.

The set top box also creates on screen display (OSD) graphics to transmit to the sink device. The system inputs the OSD data to the TSB43DA42 asynchronous transmit FIFO. The TSB43DA42 transmits the OSD using asynchronous packets to the sink device.

PACKAGING INFORMATION

Orderable Device	Status (1)	Package Type	Package Drawing	Pins	Package Qty	Eco Plan (2)	Lead/Ball Finish (6)	MSL Peak Temp (3)	Op Temp (°C)	Device Marking (4/5)	Samples
TSB43DA42AZHC	LIFEBUY	BGA MICROSTAR	ZHC	196	126	Green (RoHS & no Sb/Br)	SNAGCU	Level-3-260C-168 HR	0 to 0	TSB43DA42A	
TSB43DA42AZHCR	LIFEBUY	BGA MICROSTAR	ZHC	196	1000	Green (RoHS & no Sb/Br)	SNAGCU	Level-3-260C-168 HR	0 to 0	TSB43DA42A	

(1) The marketing status values are defined as follows:

ACTIVE: Product device recommended for new designs.

LIFEBUY: TI has announced that the device will be discontinued, and a lifetime-buy period is in effect.

NRND: Not recommended for new designs. Device is in production to support existing customers, but TI does not recommend using this part in a new design.

PREVIEW: Device has been announced but is not in production. Samples may or may not be available.

OBSOLETE: TI has discontinued the production of the device.

(2) **RoHS:** TI defines "RoHS" to mean semiconductor products that are compliant with the current EU RoHS requirements for all 10 RoHS substances, including the requirement that RoHS substance do not exceed 0.1% by weight in homogeneous materials. Where designed to be soldered at high temperatures, "RoHS" products are suitable for use in specified lead-free processes. TI may reference these types of products as "Pb-Free".

RoHS Exempt: TI defines "RoHS Exempt" to mean products that contain lead but are compliant with EU RoHS pursuant to a specific EU RoHS exemption.

Green: TI defines "Green" to mean the content of Chlorine (Cl) and Bromine (Br) based flame retardants meet JS709B low halogen requirements of <=1000ppm threshold. Antimony trioxide based flame retardants must also meet the <=1000ppm threshold requirement.

(3) MSL, Peak Temp. - The Moisture Sensitivity Level rating according to the JEDEC industry standard classifications, and peak solder temperature.

(4) There may be additional marking, which relates to the logo, the lot trace code information, or the environmental category on the device.

(5) Multiple Device Markings will be inside parentheses. Only one Device Marking contained in parentheses and separated by a "~" will appear on a device. If a line is indented then it is a continuation of the previous line and the two combined represent the entire Device Marking for that device.

(6) Lead/Ball Finish - Orderable Devices may have multiple material finish options. Finish options are separated by a vertical ruled line. Lead/Ball Finish values may wrap to two lines if the finish value exceeds the maximum column width.

Important Information and Disclaimer:The information provided on this page represents TI's knowledge and belief as of the date that it is provided. TI bases its knowledge and belief on information provided by third parties, and makes no representation or warranty as to the accuracy of such information. Efforts are underway to better integrate information from third parties. TI has taken and continues to take reasonable steps to provide representative and accurate information but may not have conducted destructive testing or chemical analysis on incoming materials and chemicals. TI and TI suppliers consider certain information to be proprietary, and thus CAS numbers and other limited information may not be available for release.

In no event shall TI's liability arising out of such information exceed the total purchase price of the TI part(s) at issue in this document sold by TI to Customer on an annual basis.

TAPE AND REEL INFORMATION



QUADRANT ASSIGNMENTS FOR PIN 1 ORIENTATION IN TAPE



*All dimensions are nominal

Device	Package Type	Package Drawing	Pins	SPQ	Reel Diameter (mm)	Reel Width W1 (mm)	A0 (mm)	B0 (mm)	K0 (mm)	P1 (mm)	W (mm)	Pin1 Quadrant
TSB43DA42AZHCR	BGA MICROSTAR	ZHC	196	1000	330.0	24.4	15.25	15.25	2.6	20.0	24.0	Q1

TAPE AND REEL BOX DIMENSIONS



*All dimensions are nominal

Device	Package Type	Package Drawing	Pins	SPQ	Length (mm)	Width (mm)	Height (mm)
TSB43DA42AZHCR	BGA MICROSTAR	ZHC	196	1000	336.6	336.6	41.3

ZHC (S-PBGA-N196)

PLASTIC BALL GRID ARRAY

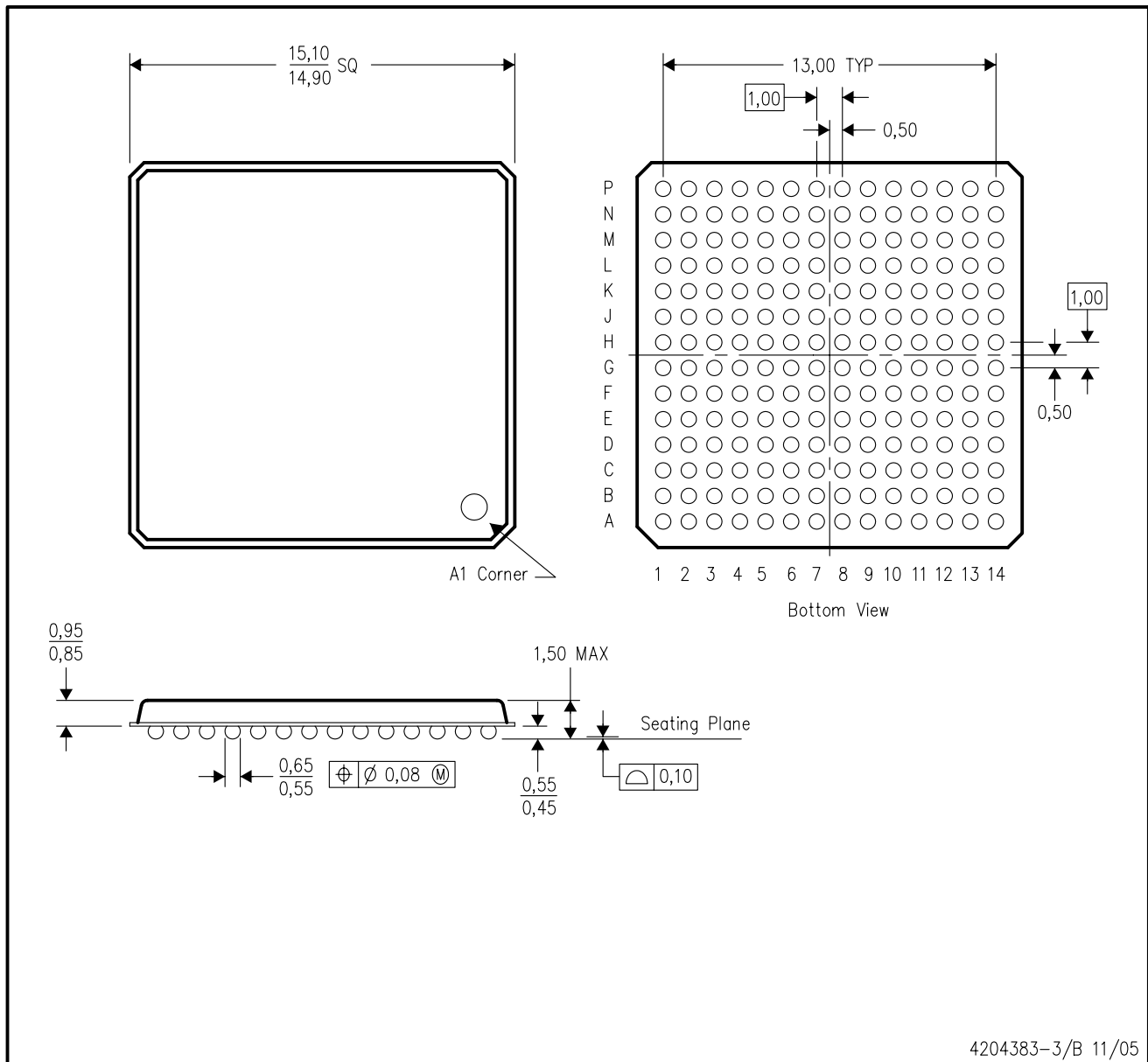

- NOTES:
- A. All linear dimensions are in millimeters.
 - B. This drawing is subject to change without notice.
 - C. Micro Star BGA configuration
 - D. This is a lead-free solder ball design.

IMPORTANT NOTICE AND DISCLAIMER

TI PROVIDES TECHNICAL AND RELIABILITY DATA (INCLUDING DATASHEETS), DESIGN RESOURCES (INCLUDING REFERENCE DESIGNS), APPLICATION OR OTHER DESIGN ADVICE, WEB TOOLS, SAFETY INFORMATION, AND OTHER RESOURCES "AS IS" AND WITH ALL FAULTS, AND DISCLAIMS ALL WARRANTIES, EXPRESS AND IMPLIED, INCLUDING WITHOUT LIMITATION ANY IMPLIED WARRANTIES OF MERCHANTABILITY, FITNESS FOR A PARTICULAR PURPOSE OR NON-INFRINGEMENT OF THIRD PARTY INTELLECTUAL PROPERTY RIGHTS.

These resources are intended for skilled developers designing with TI products. You are solely responsible for (1) selecting the appropriate TI products for your application, (2) designing, validating and testing your application, and (3) ensuring your application meets applicable standards, and any other safety, security, or other requirements. These resources are subject to change without notice. TI grants you permission to use these resources only for development of an application that uses the TI products described in the resource. Other reproduction and display of these resources is prohibited. No license is granted to any other TI intellectual property right or to any third party intellectual property right. TI disclaims responsibility for, and you will fully indemnify TI and its representatives against, any claims, damages, costs, losses, and liabilities arising out of your use of these resources.

TI's products are provided subject to TI's Terms of Sale (www.ti.com/legal/termsofsale.html) or other applicable terms available either on ti.com or provided in conjunction with such TI products. TI's provision of these resources does not expand or otherwise alter TI's applicable warranties or warranty disclaimers for TI products.

Mailing Address: Texas Instruments, Post Office Box 655303, Dallas, Texas 75265
Copyright © 2019, Texas Instruments Incorporated

Looking for pricing, stock, or lifecycle information?

Click below to explore more details on WIN SOURCE:

 [View TSB43DB42GHC](#) on WIN SOURCE

 [Texas Instruments](#) Information

Optimize Your Supply Chain with WIN SOURCE Solutions

-  Global Sourcing Solution
-  Obsolete Management
-  Cost Control Management
-  Shortage Management
-  Alternative Solution
-  Excess Inventory Management