



**THE DATASHEET OF  
SN74ABTE16245DLR**



# SN54ABTE16245, SN74ABTE16245 16-BIT INCIDENT-WAVE SWITCHING BUS TRANSCEIVERS WITH 3-STATE OUTPUTS

SCBS226J – JULY 1993 – REVISED DECEMBER 2001

- Members of the Texas Instruments Widebus™ Family
- Support the VME64 ETL Specification
- Reduced, TTL-Compatible, Input Threshold Range
- High-Drive Outputs ( $I_{OH} = -60$  mA,  $I_{OL} = 90$  mA) Support 25- $\Omega$  Incident-Wave Switching
- $V_{CCBIAS}$  Pin Minimizes Signal Distortion During Live Insertion
- Internal Pullup Resistor on  $\overline{OE}$  Keeps Outputs in High-Impedance State During Power Up or Power Down
- Distributed  $V_{CC}$  and GND Pins Minimize High-Speed Switching Noise
- Equivalent 25- $\Omega$  Series Damping Resistor on B Port
- Bus Hold on Data Inputs Eliminates the Need for External Pullup/Pulldown Resistors

## description

The 'ABTE16245 devices are 16-bit (dual-octal) noninverting 3-state transceivers designed for synchronous two-way communication between data buses. The control-function implementation minimizes external timing requirements. These devices can be used as two 8-bit transceivers or one 16-bit transceiver. They allow data transmission from the A bus to the B bus or from the B bus to the A bus, depending on the logic level at the direction-control (DIR) input. The output-enable ( $\overline{OE}$ ) input can be used to disable the device so that the buses are effectively isolated. When  $\overline{OE}$  is low, the device is active.

The B port has an equivalent 25- $\Omega$  series output resistor to reduce ringing. Active bus-hold inputs also are on the B port to hold unused or floating inputs at a valid logic level.

The A port provides for the precharging of the outputs via  $V_{CCBIAS}$ , which establishes a voltage between 1.3 V and 1.7 V when  $V_{CC}$  is not connected.

Active bus-hold circuitry holds unused or undriven inputs at a valid logic state. Use of pullup or pulldown resistors with the bus-hold circuitry is not recommended.

SN54ABTE16245 . . . WD PACKAGE  
SN74ABTE16245 . . . DGG OR DL PACKAGE  
(TOP VIEW)

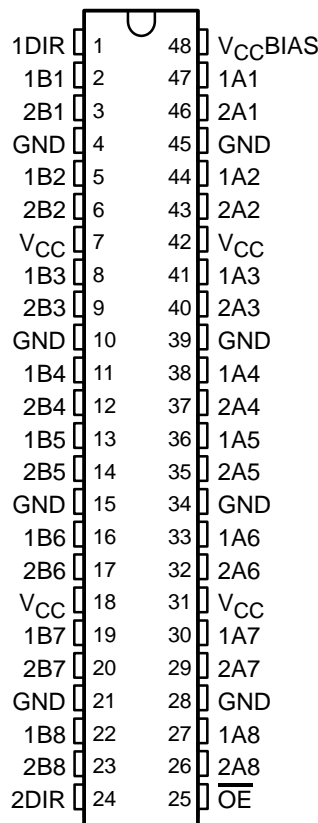

Please be aware that an important notice concerning availability, standard warranty, and use in critical applications of Texas Instruments semiconductor products and disclaimers thereto appears at the end of this data sheet.

Widebus is a trademark of Texas Instruments.

PRODUCTION DATA information is current as of publication date. Products conform to specifications per the terms of Texas Instruments standard warranty. Production processing does not necessarily include testing of all parameters.

 **TEXAS  
INSTRUMENTS**

POST OFFICE BOX 655303 • DALLAS, TEXAS 75265

Copyright © 2001, Texas Instruments Incorporated  
On products compliant to MIL-PRF-38535, all parameters are tested unless otherwise noted. On all other products, production processing does not necessarily include testing of all parameters.

# SN54ABTE16245, SN74ABTE16245 16-BIT INCIDENT-WAVE SWITCHING BUS TRANSCEIVERS WITH 3-STATE OUTPUTS

SCBS226J – JULY 1993 – REVISED DECEMBER 2001

## ORDERING INFORMATION

| T <sub>A</sub> | PACKAGE†  |               | ORDERABLE PART NUMBER | TOP-SIDE MARKING |
|----------------|-----------|---------------|-----------------------|------------------|
| –40°C to 85°C  | SSOP – DL | Tube          | SN74ABTE16245DL       | ABTE16245        |
|                |           | Tape and reel | SN74ABTE16245DLR      |                  |
| –55°C to 125°C | CFP – WD  | Tape and reel | SN74ABTE16245DGGR     | ABTE16245        |
|                |           | Tube          | SNJ54ABTE16245WD      | SNJ54ABTE16245WD |

† Package drawings, standard packing quantities, thermal data, symbolization, and PCB design guidelines are available at [www.ti.com/sc/package](http://www.ti.com/sc/package).

## FUNCTION TABLE (each 8-bit section)

| INPUTS          |     | OPERATION       |
|-----------------|-----|-----------------|
| $\overline{OE}$ | DIR |                 |
| L               | L   | A data to B bus |
| L               | H   | B data to A bus |
| H               | X   | Isolation       |

## logic diagram (positive logic)

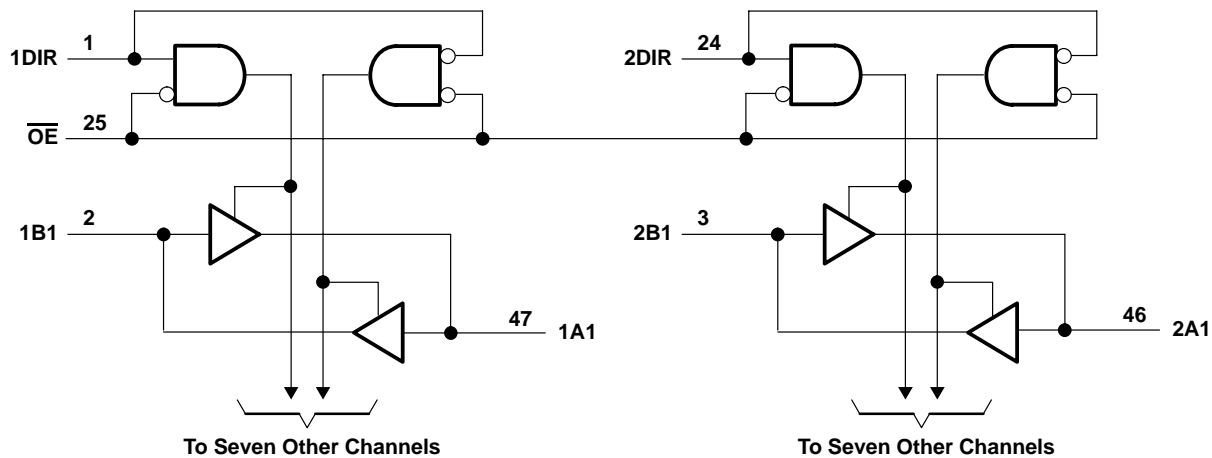

## absolute maximum ratings over operating free-air temperature range (unless otherwise noted)‡

|  |                 |
|--|-----------------|
| Supply voltage range, V <sub>CC</sub> and V <sub>CC</sub> BIAS                           | –0.5 V to 7 V   |
| Input voltage range, V <sub>I</sub> (except I/O ports) (see Note 1)                      | –0.5 V to 7 V   |
| Voltage range applied to any output in the high state or power-off state, V <sub>O</sub> | –0.5 V to 5.5 V |
| Current into any output in the low state, I <sub>O</sub>                                 | 128 mA          |
| Input clamp current, I <sub>IK</sub> (V <sub>I</sub> < 0)                                | –18 mA          |
| Output clamp current, I <sub>OK</sub> (V <sub>O</sub> < 0)                               | –50 mA          |
| Package thermal impedance, $\theta_{JA}$ (see Note 2): DGG package                       | 70°C/W          |
| DL package   | 63°C/W          |
| Storage temperature range, T <sub>stg</sub>  | –65°C to 150°C  |

‡ Stresses beyond those listed under “absolute maximum ratings” may cause permanent damage to the device. These are stress ratings only, and functional operation of the device at these or any other conditions beyond those indicated under “recommended operating conditions” is not implied. Exposure to absolute-maximum-rated conditions for extended periods may affect device reliability.

NOTES: 1. The input and output negative-voltage ratings may be exceeded if the input and output clamp-current ratings are observed.  
2. The package thermal impedance is calculated in accordance with JESD 51-7.



POST OFFICE BOX 655303 • DALLAS, TEXAS 75265

# SN54ABTE16245, SN74ABTE16245 16-BIT INCIDENT-WAVE SWITCHING BUS TRANSCEIVERS WITH 3-STATE OUTPUTS

SCBS226J – JULY 1993 – REVISED DECEMBER 2001

## recommended operating conditions (see Note 3)

|                            |                                    |                        | SN54ABTE16245 |     |          | SN74ABTE16245 |     |          | UNIT |
|----------------------------|------------------------------------|------------------------|---------------|-----|----------|---------------|-----|----------|------|
|                            |                                    |                        | MIN           | NOM | MAX      | MIN           | NOM | MAX      |      |
| $V_{CC}$ ,<br>$V_{CCBIAS}$ | Supply voltage                     |                        | 4.5           | 5   | 5.5      | 4.5           | 5   | 5.5      | V    |
| $V_{IH}$                   | High-level input voltage           | $\overline{OE}$        | 2             |     |          | 2             |     |          | V    |
|                            |                                    | Except $\overline{OE}$ | 1.6           |     |          | 1.6           |     |          |      |
| $V_{IL}$                   | Low-level input voltage            | $\overline{OE}$        |               |     | 0.8      |               |     | 0.8      | V    |
|                            |                                    | Except $\overline{OE}$ |               |     | 1.4      |               |     | 1.4      |      |
| $V_I$                      | Input voltage                      |                        | 0             |     | $V_{CC}$ | 0             |     | $V_{CC}$ | V    |
| $I_{OH}$                   | High-level output current          | B bus                  |               |     | -12      |               |     | -12      | mA   |
|                            |                                    | A bus                  |               |     | -24      |               |     | -60      |      |
| $I_{OL}$                   | Low-level output current           | B bus                  |               |     | 12       |               |     | 12       | mA   |
|                            |                                    | A bus                  |               |     | 64       |               |     | 90       |      |
| $\Delta t/\Delta v$        | Input transition rise or fall rate | Outputs enabled        |               |     | 10       |               |     | 10       | ns/V |
| $T_A$                      | Operating free-air temperature     |                        | -55           |     | 125      | -40           |     | 85       | °C   |

NOTE 3: All unused control inputs of the device must be held at  $V_{CC}$  or GND to ensure proper device operation. Refer to the TI application report, *Implications of Slow or Floating CMOS Inputs*, literature number SCBA004.

# SN54ABTE16245, SN74ABTE16245 16-BIT INCIDENT-WAVE SWITCHING BUS TRANSCEIVERS WITH 3-STATE OUTPUTS

SCBS226J – JULY 1993 – REVISED DECEMBER 2001

electrical characteristics over recommended operating free-air temperature range (unless otherwise noted)

| PARAMETER             | TEST CONDITIONS  | SN54ABTE16245  |                          |                         | SN74ABTE16245 |      |                      | UNIT |  |
|-----------------------|--|--|--------------------------|-------------------------|---------------|------|----------------------|------|--|
|                       |  | MIN  | TYP†                     | MAX                     | MIN           | TYP† | MAX                  |      |  |
| V <sub>IK</sub>       | V <sub>CC</sub> = 4.5 V, I <sub>I</sub> = -18 mA                                       |  |                          | -1.2                    |               |      | -1.2                 | V    |  |
| V <sub>OH</sub>       | B port   | V <sub>CC</sub> = 5.5 V, I <sub>OH</sub> = -100 μA                                   |                          | V <sub>CC</sub> -0.2    |               |      | V <sub>CC</sub> -0.2 |      |  |
|                       |  | V <sub>CC</sub> = 4.5 V  | I <sub>OH</sub> = -1 mA  | 2.4                     |               | 2.4  |                      |      |  |
|                       | A port   | V <sub>CC</sub> = 5.5 V, I <sub>OH</sub> = -1 mA                                     |                          |                         |               | 4.5  |                      | 4.5  |  |
|                       |  | V <sub>CC</sub> = 4.5 V  | I <sub>OH</sub> = -32 mA | 2.4                     |               | 2.4  |                      |      |  |
|                       |  |  | I <sub>OH</sub> = -64 mA |                         |               | 2    |                      |      |  |
|                       |  |  | I <sub>OH</sub> = -12 mA |                         |               |      |                      |      |  |
| V <sub>OL</sub>       | B port   | V <sub>CC</sub> = 4.5 V  |                          | I <sub>OL</sub> = 1 mA  |               | 0.4  |                      |      |  |
|                       |  |  |                          | I <sub>OL</sub> = 12 mA |               | 0.8  |                      |      |  |
|                       | A port   | V <sub>CC</sub> = 4.5 V  |                          | I <sub>OL</sub> = 64 mA |               | 0.55 |                      |      |  |
|                       |  |  |                          | I <sub>OL</sub> = 90 mA |               | 0.9  |                      |      |  |
| I <sub>I</sub> (hold) | B port   | V <sub>CC</sub> = 4.5 V  |                          | V <sub>I</sub> = 0.8 V  |               | 100  |                      |      |  |
|                       |  |  |                          | V <sub>I</sub> = 2 V    |               | -100 |                      |      |  |
|                       |  | V <sub>CC</sub> = 5.5 V, V <sub>I</sub> = 0 to 5.5 V                                 |                          | ±500                    |               | ±500 |                      |      |  |
| I <sub>I</sub>        | Control inputs   | V <sub>CC</sub> = 5.5 V, V <sub>I</sub> = V <sub>CC</sub> or GND                     |                          | ±1                      |               | ±1   |                      |      |  |
|                       | A or B ports   |  |                          | ±20                     |               | ±20  |                      |      |  |
| I <sub>OZH</sub> ‡    | A port   | V <sub>CC</sub> = 5.5 V, V <sub>O</sub> = 2.7 V                                      |                          | 10                      |               | 10   |                      |      |  |
| I <sub>OZL</sub> ‡    | A port   | V <sub>CC</sub> = 5.5 V, V <sub>O</sub> = 0.5 V                                      |                          | -10                     |               | -10  |                      |      |  |
| I <sub>O</sub>        | A port   | V <sub>CC</sub> = 5.5 V, V <sub>O</sub> = 2.5 V                                      |                          | -50                     | -120          | -180 | -50                  | -180 |  |
|                       | B port   |  |                          | -25                     | -52           | -90  | -25                  | -90  |  |
| I <sub>off</sub>      | V <sub>CC</sub> = 0, V <sub>I</sub> or V <sub>O</sub> ≤ 4.5 V, V <sub>CCBIAS</sub> = 0 |  | ±100                     |                         | ±100          |      |                      |      |  |
| I <sub>CC</sub>       | A or B ports   | V <sub>CC</sub> = 5.5 V, I <sub>O</sub> = 0, V <sub>I</sub> = V <sub>CC</sub> or GND |                          | Outputs high            |               | 28   |                      | 36   |  |
|                       |  |  |                          | Outputs low             |               | 38   |                      | 48   |  |
|                       |  |  |                          | Outputs disabled        |               | 20   |                      | 32   |  |
| I <sub>CCD</sub>      | A or B ports   | V <sub>CC</sub> = 5 V, C <sub>L</sub> = 50 pF  |                          | $\overline{OE}$ high    |               | 0.02 |                      |      |  |
|                       |  |  |                          | $\overline{OE}$ low     |               | 0.33 |                      |      |  |
| C <sub>i</sub>        | Control inputs   | V <sub>I</sub> = 2.5 V or 0.5 V  |                          | 10                      |               | 2.5  |                      | 4    |  |
| C <sub>io</sub>       | I/O ports  | V <sub>O</sub> = 2.5 V or 0.5 V  |                          | 13                      |               | 4.5  |                      | 8    |  |

† All typical values are at V<sub>CC</sub> = 5 V, T<sub>A</sub> = 25°C.

‡ The parameters I<sub>OZH</sub> and I<sub>OZL</sub> include the input leakage current.



# SN54ABTE16245, SN74ABTE16245 16-BIT INCIDENT-WAVE SWITCHING BUS TRANSCEIVERS WITH 3-STATE OUTPUTS

SCBS226J – JULY 1993 – REVISED DECEMBER 2001

## live-insertion specifications over recommended operating free-air temperature range

| PARAMETER                              |        | TEST CONDITIONS  |   | SN54ABTE16245 |      |      | SN74ABTE16245 |      |      | UNIT |
|--|--------|--|---|---------------|------|------|---------------|------|------|------|
|  |        |  |   | MIN           | TYP† | MAX  | MIN           | TYP† | MAX  |      |
| I <sub>CC</sub> (V <sub>CC</sub> BIAS) |        | V <sub>CC</sub> = 0 to 4.5 V, V <sub>CC</sub> BIAS = 4.5 V to 5.5 V,<br>I <sub>O</sub> (DC) = 0      |   | 250           | 700  |      | 250           | 700  | μA   |      |
|  |        | V <sub>CC</sub> = 4.5 V to 5.5 V‡, V <sub>CC</sub> BIAS = 4.5 V to 5.5 V,<br>I <sub>O</sub> (DC) = 0 |   | 20            |      |      | 20            |      |      |      |
| V <sub>O</sub>                         | A port | V <sub>CC</sub> = 0  | V <sub>CC</sub> BIAS = 4.5 V to 5.5 V   | 1.1           | 1.5  | 1.9  | 1.1           | 1.5  | 1.9  | V    |
|  |        |  | V <sub>CC</sub> BIAS = 4.75 V to 5.25 V | 1.3           | 1.5  | 1.7  | 1.3           | 1.5  | 1.7  |      |
| I <sub>O</sub>                         | A port | V <sub>CC</sub> = 0, V <sub>CC</sub> BIAS = 4.5 V  | V <sub>O</sub> = 0                      | -20           |      | -100 | -20           |      | -100 | μA   |
|  |        |  | V <sub>O</sub> = 3 V                    | 20            |      | 100  | 20            |      | 100  | μA   |

† All typical values are at V<sub>CC</sub> = 5 V, T<sub>A</sub> = 25°C.

‡ V<sub>CC</sub> - 0.5 V < V<sub>CC</sub>BIAS

## switching characteristics over recommended ranges of supply voltage and operating free-air temperature, C<sub>L</sub> = 50 pF (unless otherwise noted) (see Figure 2)

| PARAMETER        | FROM (INPUT) | TO (OUTPUT) | V <sub>CC</sub> = 5 V,<br>T <sub>A</sub> = 25°C |     |     | SN54ABTE16245 |     | SN74ABTE16245 |     | UNIT |
|------------------|--------------|-------------|---|-----|-----|---------------|-----|---------------|-----|------|
|                  |              |             | MIN   | TYP | MAX | MIN           | MAX | MIN           | MAX |      |
| t <sub>PLH</sub> | A            | B           | 1.5   | 3.3 | 4.2 | 1.5           | 5.4 | 1.5           | 5.2 | ns   |
| t <sub>PHL</sub> |              |             | 1.5   | 3.8 | 4.6 | 1.5           | 5.4 | 1.5           | 5.2 |      |
| t <sub>PLH</sub> | B            | A           | 1.5   | 3   | 3.8 | 1.5           | 4.7 | 1.5           | 4.5 | ns   |
| t <sub>PHL</sub> |              |             | 1.5   | 3.1 | 4   | 1.5           | 4.7 | 1.5           | 4.5 |      |
| t <sub>PZH</sub> | OE           | A           | 2   | 3.9 | 5.3 | 2             | 6.4 | 2             | 6.2 | ns   |
| t <sub>PZL</sub> |              |             | 2   | 4.4 | 5.9 | 2             | 7   | 2             | 6.8 |      |
| t <sub>PZH</sub> | OE           | B           | 2   | 4.5 | 6   | 2             | 7.3 | 2             | 7.1 | ns   |
| t <sub>PZL</sub> |              |             | 2   | 5   | 6.4 | 2             | 7.5 | 2             | 7.3 |      |
| t <sub>PHZ</sub> | OE           | A           | 2   | 4.9 | 5.9 | 2             | 7   | 2             | 6.7 | ns   |
| t <sub>PLZ</sub> |              |             | 2   | 3.7 | 4.6 | 2             | 5.4 | 2             | 5.1 |      |
| t <sub>PHZ</sub> | OE           | B           | 2   | 5.2 | 6.2 | 2             | 7.2 | 2             | 7   | ns   |
| t <sub>PLZ</sub> |              |             | 2   | 4   | 5   | 2             | 5.8 | 2             | 5.5 |      |



# SN54ABTE16245, SN74ABTE16245 16-BIT INCIDENT-WAVE SWITCHING BUS TRANSCEIVERS WITH 3-STATE OUTPUTS

SCBS226J – JULY 1993 – REVISED DECEMBER 2001

extended switching characteristics over recommended ranges of supply voltage and operating free-air temperature,  $C_L = 50$  pF (unless otherwise noted) (see Figure 2)

| PARAMETER      | FROM (INPUT) | TO (OUTPUT) | LOAD                | $V_{CC} = 5$ V,<br>$T_A = 25^\circ$ C |     |     | SN54ABTE16245 |     | SN74ABTE16245 |     | UNIT |
|----------------|--------------|-------------|---------------------|---------------------------------------|-----|-----|---------------|-----|---------------|-----|------|
|                |              |             |                     | MIN                                   | TYP | MAX | MIN           | MAX | MIN           | MAX |      |
| $t_{PLH}$      | B            | A           | $R_X = 13 \Omega$   | 1.5                                   | 3.2 | 4   | 1.5           | 5   | 1.5           | 4.8 | ns   |
| $t_{PHL}$      |              |             |                     | 1.5                                   | 3.8 | 4.7 | 1.5           | 5.8 | 1.5           | 5.6 |      |
| $t_{PLH}$      | B            | A           | $R_X = 26 \Omega$   | 1.5                                   | 3.1 | 4   | 1.5           | 4.8 | 1.5           | 4.6 | ns   |
| $t_{PHL}$      |              |             |                     | 1.5                                   | 3.5 | 4.4 | 1.5           | 5.2 | 1.5           | 4.9 |      |
| $t_{PLH}$      | B            | A           | $R_X = 56 \Omega$   | 1.5                                   | 3   | 3.8 | 1.5           | 4.7 | 1.5           | 4.5 | ns   |
| $t_{PHL}$      |              |             |                     | 1.5                                   | 3.3 | 4.2 | 1.5           | 5.1 | 1.5           | 4.7 |      |
| $t_{sk(p)}$    | B            | A           | $R_X = \text{Open}$ |                                       | 0.1 | 0.6 |               | 2   |               | 2   | ns   |
|                | A            | B           | $R_X = \text{Open}$ |                                       | 0.4 | 0.8 |               | 2   |               | 2   |      |
|                | B            | A           | $R_X = 26 \Omega$   |                                       | 0.3 | 0.8 |               | 2   |               | 2   |      |
| $t_{sk(o)}$    | B            | A           | $R_X = \text{Open}$ |                                       | 0.3 | 0.7 |               | 1.3 |               | 1.3 | ns   |
|                | A            | B           | $R_X = \text{Open}$ |                                       | 0.7 | 1.1 |               | 1.3 |               | 1.3 |      |
|                | B            | A           | $R_X = 26 \Omega$   |                                       | 0.5 | 1   |               | 1.3 |               | 1.3 |      |
| $t_t^\dagger$  | B            | A           | $R_X = 26 \Omega$   | 0.5                                   | 0.8 | 1.5 | 0.5           | 1.5 | 0.5           | 1.5 | ns   |
| $t_t^\ddagger$ | A            | B           | $R_X = \text{Open}$ | 3.5                                   | 5.5 | 7.3 | 3.5           | 8.1 | 3.5           | 7.9 | ns   |

$^\dagger t_t$  is measured between 1 V and 2 V of the output waveform.

$^\ddagger t_t$  is measured between 10% and 90% of the output waveform.

extended output characteristics over recommended ranges of supply voltage and operating free-air temperature,  $C_L = 50$  pF (see Figures 1 and 2)

| PARAMETER      | FROM (INPUT) | TO (OUTPUT) | TEST CONDITIONS  | LOAD                              | SN54ABTE16245 |     | SN74ABTE16245 |     | UNIT |
|----------------|--------------|-------------|--|-----------------------------------|---------------|-----|---------------|-----|------|
|                |              |             |  |                                   | MIN           | MAX | MIN           | MAX |      |
| $t_{sk(temp)}$ | A            | B           | $V_{CC} = \text{constant},$<br>$\Delta T_A = 20^\circ$ C |                                   |               | 3   |               | 2.5 | ns   |
|                | B            | A           |  | $R_X = 56 \Omega$                 |               | 4.5 |               | 4   |      |
| $t_{sk(load)}$ | B            | B           | $V_{CC} = \text{constant},$<br>Temperature = constant    | $R_X = 13, 26,$<br>or $56 \Omega$ |               | 4.5 |               | 4   | ns   |



**SN54ABTE16245, SN74ABTE16245**  
**16-BIT INCIDENT-WAVE SWITCHING BUS TRANSCEIVERS**  
**WITH 3-STATE OUTPUTS**

SCBS226J – JULY 1993 – REVISED DECEMBER 2001

**PARAMETER MEASUREMENT INFORMATION**

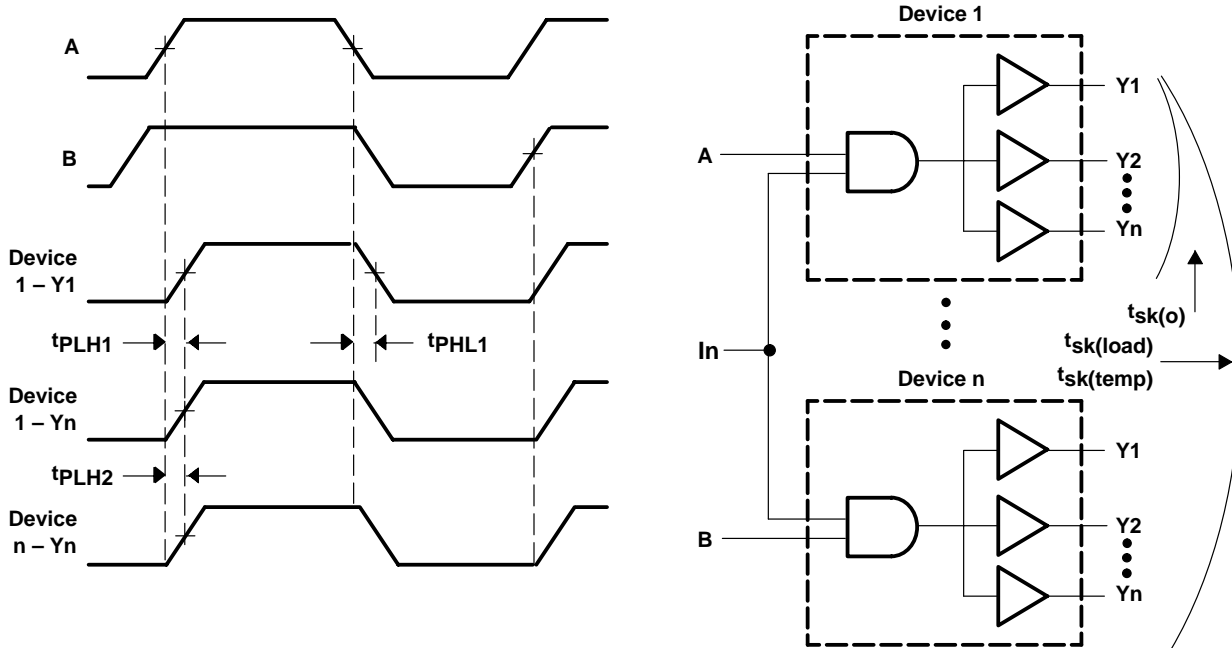

- NOTES:
- A. Pulse skew,  $t_{sk(p)}$ , is defined as the difference in propagation-delay times  $t_{PLH1}$  and  $t_{PHL1}$  on the same terminal at identical operating conditions.
  - B. Output skew,  $t_{sk(o)}$ , is defined as the difference in propagation delay of any two outputs of the same device switching in the same direction (e.g.,  $|t_{PLH1} - t_{PLH2}|$ ).
  - C. Temperature skew,  $t_{sk(temp)}$ , is the output skew of two devices, both having the same value of  $V_{CC} \pm 1\%$  and with package temperature differences of  $20^{\circ}\text{C}$ .
  - D. Load skew,  $t_{sk(load)}$ , is measured with  $R_X$  in Figure 2 at  $13\ \Omega$  for one unit and  $56\ \Omega$  for the other unit.

**Figure 1. Voltage Waveforms for Extended Characteristics**

**SN54ABTE16245, SN74ABTE16245**  
**16-BIT INCIDENT-WAVE SWITCHING BUS TRANSCEIVERS**  
**WITH 3-STATE OUTPUTS**

SCBS226J – JULY 1993 – REVISED DECEMBER 2001

**PARAMETER MEASUREMENT INFORMATION**

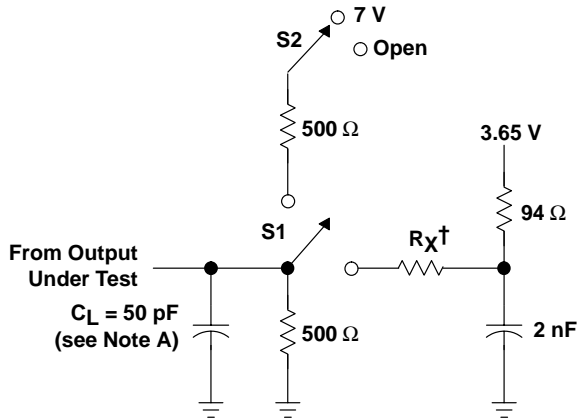

†  $R_X = 13, 26, \text{ or } 56 \Omega$

| SWITCHING TABLE LOADS            | S1 | S2   |
|----------------------------------|----|------|
| $t_{PLH}/t_{PHL}$ (A and B port) | Up | Open |
| $t_{PLZ}/t_{PZL}$                | Up | 7 V  |
| $t_{PHZ}/t_{PZH}$                | Up | Open |

| EXTENDED SWITCHING TABLE LOADS    | S1   | S2   |
|-----------------------------------|------|------|
| $t_{PLH}/t_{PHL}/t_{sk}$ (A port) | Down | X    |
| $t_{PLH}/t_{PHL}/t_{sk}$ (B port) | Up   | Open |
| $t_t$ (A port) (see Note E)       | Down | X    |
| $t_t$ (B port) (see Note F)       | Up   | Open |

**LOAD CIRCUIT FOR OUTPUTS**

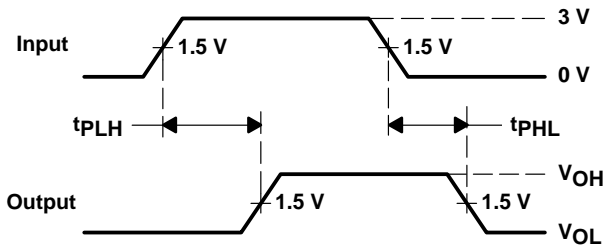

**VOLTAGE WAVEFORMS PROPAGATION DELAY TIMES**

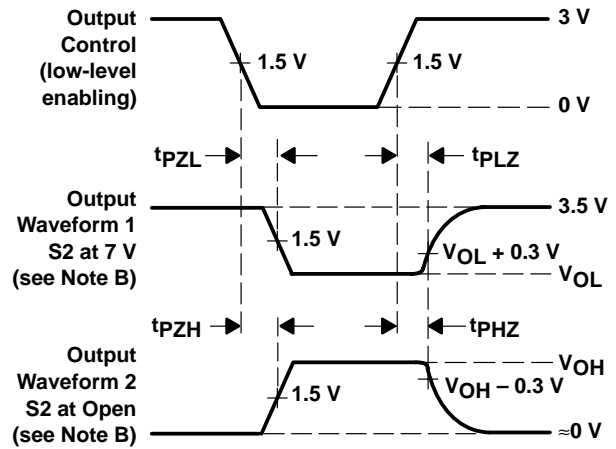

**VOLTAGE WAVEFORMS ENABLE AND DISABLE TIMES**

- NOTES: A.  $C_L$  includes probe and jig capacitance.  
 B. Waveform 1 is for an output with internal conditions such that the output is low except when disabled by the output control. Waveform 2 is for an output with internal conditions such that the output is high except when disabled by the output control.  
 C. All input pulses are supplied by generators having the following characteristics:  $PRR \leq 10 \text{ MHz}$ ,  $Z_O = 50 \Omega$ ,  $t_r \leq 2.5 \text{ ns}$ ,  $t_f \leq 2.5 \text{ ns}$ .  
 D. The outputs are measured one at a time with one transition per measurement.  
 E.  $t_t$  is measured between 1 V and 2 V of the output waveform.  
 F.  $t_t$  is measured between 10% and 90% of the output waveform.

**Figure 2. Load Circuit and Voltage Waveforms**

**PACKAGING INFORMATION**

| Orderable Device  | Status<br>(1) | Package Type | Package Drawing | Pins | Package Qty | Eco Plan<br>(2)         | Lead/Ball Finish<br>(6) | MSL Peak Temp<br>(3) | Op Temp (°C) | Device Marking<br>(4/5) | Samples                 |
|-------------------|---------------|--------------|-----------------|------|-------------|-------------------------|-------------------------|----------------------|--------------|-------------------------|-------------------------|
| SN74ABTE16245DGGR | ACTIVE        | TSSOP        | DGG             | 48   | 2000        | Green (RoHS & no Sb/Br) | CU NIPDAU               | Level-1-260C-UNLIM   | -40 to 85    | ABTE16245               | <a href="#">Samples</a> |
| SN74ABTE16245DL   | ACTIVE        | SSOP         | DL              | 48   | 25          | Green (RoHS & no Sb/Br) | CU NIPDAU               | Level-1-260C-UNLIM   | -40 to 85    | ABTE16245               | <a href="#">Samples</a> |
| SN74ABTE16245DLG4 | ACTIVE        | SSOP         | DL              | 48   | 25          | Green (RoHS & no Sb/Br) | CU NIPDAU               | Level-1-260C-UNLIM   | -40 to 85    | ABTE16245               | <a href="#">Samples</a> |
| SN74ABTE16245DLR  | ACTIVE        | SSOP         | DL              | 48   | 1000        | Green (RoHS & no Sb/Br) | CU NIPDAU               | Level-1-260C-UNLIM   | -40 to 85    | ABTE16245               | <a href="#">Samples</a> |

(1) The marketing status values are defined as follows:

**ACTIVE:** Product device recommended for new designs.

**LIFEBUY:** TI has announced that the device will be discontinued, and a lifetime-buy period is in effect.

**NRND:** Not recommended for new designs. Device is in production to support existing customers, but TI does not recommend using this part in a new design.

**PREVIEW:** Device has been announced but is not in production. Samples may or may not be available.

**OBSOLETE:** TI has discontinued the production of the device.

(2) **RoHS:** TI defines "RoHS" to mean semiconductor products that are compliant with the current EU RoHS requirements for all 10 RoHS substances, including the requirement that RoHS substance do not exceed 0.1% by weight in homogeneous materials. Where designed to be soldered at high temperatures, "RoHS" products are suitable for use in specified lead-free processes. TI may reference these types of products as "Pb-Free".

**RoHS Exempt:** TI defines "RoHS Exempt" to mean products that contain lead but are compliant with EU RoHS pursuant to a specific EU RoHS exemption.

**Green:** TI defines "Green" to mean the content of Chlorine (Cl) and Bromine (Br) based flame retardants meet JS709B low halogen requirements of <=1000ppm threshold. Antimony trioxide based flame retardants must also meet the <=1000ppm threshold requirement.

(3) MSL, Peak Temp. - The Moisture Sensitivity Level rating according to the JEDEC industry standard classifications, and peak solder temperature.

(4) There may be additional marking, which relates to the logo, the lot trace code information, or the environmental category on the device.

(5) Multiple Device Markings will be inside parentheses. Only one Device Marking contained in parentheses and separated by a "-" will appear on a device. If a line is indented then it is a continuation of the previous line and the two combined represent the entire Device Marking for that device.

(6) Lead/Ball Finish - Orderable Devices may have multiple material finish options. Finish options are separated by a vertical ruled line. Lead/Ball Finish values may wrap to two lines if the finish value exceeds the maximum column width.

**Important Information and Disclaimer:** The information provided on this page represents TI's knowledge and belief as of the date that it is provided. TI bases its knowledge and belief on information provided by third parties, and makes no representation or warranty as to the accuracy of such information. Efforts are underway to better integrate information from third parties. TI has taken and

continues to take reasonable steps to provide representative and accurate information but may not have conducted destructive testing or chemical analysis on incoming materials and chemicals. TI and TI suppliers consider certain information to be proprietary, and thus CAS numbers and other limited information may not be available for release.

In no event shall TI's liability arising out of such information exceed the total purchase price of the TI part(s) at issue in this document sold by TI to Customer on an annual basis.

## TAPE AND REEL INFORMATION



### QUADRANT ASSIGNMENTS FOR PIN 1 ORIENTATION IN TAPE



\*All dimensions are nominal

| Device            | Package Type | Package Drawing | Pins | SPQ  | Reel Diameter (mm) | Reel Width W1 (mm) | A0 (mm) | B0 (mm) | K0 (mm) | P1 (mm) | W (mm) | Pin1 Quadrant |
|-------------------|--------------|-----------------|------|------|--------------------|--------------------|---------|---------|---------|---------|--------|---------------|
| SN74ABTE16245DGGR | TSSOP        | DGG             | 48   | 2000 | 330.0              | 24.4               | 8.6     | 13.0    | 1.8     | 12.0    | 24.0   | Q1            |
| SN74ABTE16245DLR  | SSOP         | DL              | 48   | 1000 | 330.0              | 32.4               | 11.35   | 16.2    | 3.1     | 16.0    | 32.0   | Q1            |

**TAPE AND REEL BOX DIMENSIONS**

\*All dimensions are nominal

| Device            | Package Type | Package Drawing | Pins | SPQ  | Length (mm) | Width (mm) | Height (mm) |
|-------------------|--------------|-----------------|------|------|-------------|------------|-------------|
| SN74ABTE16245DGGR | TSSOP        | DGG             | 48   | 2000 | 367.0       | 367.0      | 45.0        |
| SN74ABTE16245DLR  | SSOP         | DL              | 48   | 1000 | 367.0       | 367.0      | 55.0        |

DGG (R-PDSO-G\*\*)

PLASTIC SMALL-OUTLINE PACKAGE

48 PINS SHOWN



- NOTES: A. All linear dimensions are in millimeters.  
 B. This drawing is subject to change without notice.  
 C. Body dimensions do not include mold protrusion not to exceed 0,15.  
 D. Falls within JEDEC MO-153

# MECHANICAL DATA

DL (R-PDSO-G48)

PLASTIC SMALL-OUTLINE PACKAGE



- NOTES:
- All linear dimensions are in inches (millimeters).
  - This drawing is subject to change without notice.
  - Body dimensions do not include mold flash or protrusion not to exceed 0.006 (0,15).
  - Falls within JEDEC MO-118

PowerPAD is a trademark of Texas Instruments.

## IMPORTANT NOTICE AND DISCLAIMER

TI PROVIDES TECHNICAL AND RELIABILITY DATA (INCLUDING DATASHEETS), DESIGN RESOURCES (INCLUDING REFERENCE DESIGNS), APPLICATION OR OTHER DESIGN ADVICE, WEB TOOLS, SAFETY INFORMATION, AND OTHER RESOURCES "AS IS" AND WITH ALL FAULTS, AND DISCLAIMS ALL WARRANTIES, EXPRESS AND IMPLIED, INCLUDING WITHOUT LIMITATION ANY IMPLIED WARRANTIES OF MERCHANTABILITY, FITNESS FOR A PARTICULAR PURPOSE OR NON-INFRINGEMENT OF THIRD PARTY INTELLECTUAL PROPERTY RIGHTS.

These resources are intended for skilled developers designing with TI products. You are solely responsible for (1) selecting the appropriate TI products for your application, (2) designing, validating and testing your application, and (3) ensuring your application meets applicable standards, and any other safety, security, or other requirements. These resources are subject to change without notice. TI grants you permission to use these resources only for development of an application that uses the TI products described in the resource. Other reproduction and display of these resources is prohibited. No license is granted to any other TI intellectual property right or to any third party intellectual property right. TI disclaims responsibility for, and you will fully indemnify TI and its representatives against, any claims, damages, costs, losses, and liabilities arising out of your use of these resources.

TI's products are provided subject to TI's Terms of Sale ([www.ti.com/legal/termsofsale.html](http://www.ti.com/legal/termsofsale.html)) or other applicable terms available either on [ti.com](http://ti.com) or provided in conjunction with such TI products. TI's provision of these resources does not expand or otherwise alter TI's applicable warranties or warranty disclaimers for TI products.

Mailing Address: Texas Instruments, Post Office Box 655303, Dallas, Texas 75265  
Copyright © 2019, Texas Instruments Incorporated

## Looking for pricing, stock, or lifecycle information?

Click below to explore more details on WIN SOURCE:

 [View SN74ABTE16245DLR on WIN SOURCE](#)

 [Texas Instruments](#) Information

## Optimize Your Supply Chain with WIN SOURCE Solutions

-  Global Sourcing Solution
-  Obsolete Management
-  Cost Control Management
-  Shortage Management
-  Alternative Solution
-  Excess Inventory Management