



**THE DATASHEET OF
HMC437MS8GE**





Typical Applications

Prescaler for DC to C Band PLL Applications:

- UNII, Point-to-Point & VSAT Radios
- 802.11a & HiperLAN WLAN
- Fiber Optic
- Cellular / 3G Infrastructure

Features

- SSB Phase Noise: -153 dBc/Hz @100KHz
- Wide Bandwidth
- Output Power: -1 dBm
- Single DC Supply: +5V @ 69 mA
- MS8G SMT Package

Functional Diagram

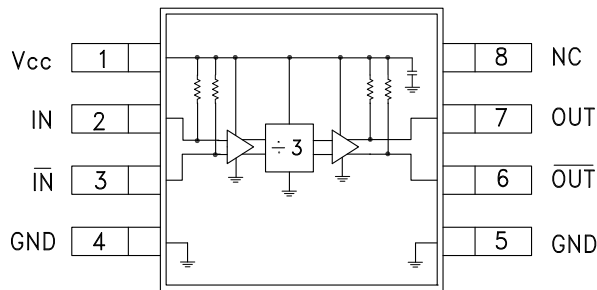

General Description

The HMC437MS8G & HMC437MS8GE are low noise Divide-by-3 Static Dividers utilizing InGaP GaAs HBT technology in low cost 8 lead surface mount plastic packages. This device operates from DC (with a square wave input) to 7 GHz input frequency from a single +5V DC supply. The low additive SSB phase noise of -153 dBc/Hz at 100 kHz offset helps the user maintain good system noise performance.

Electrical Specifications, $T_A = +25^\circ C$, 50 Ohm System, $V_{CC} = 5V$

| Parameter | Conditions | Min. | Typ. | Max. | Units |
|----------------------------------|---------------------------------------|------|------|------|--------|
| Maximum Input Frequency | | 7.0 | 7.5 | | GHz |
| Minimum Input Frequency | Sine Wave Input [1] | | 0.1 | | GHz |
| Input Power Range | $F_{in} = 1$ to 6 GHz | -12 | | +12 | dBm |
| | $F_{in} = 6$ to 7 GHz | -10 | | +10 | dBm |
| Output Power | | -4 | -1 | | dBm |
| Reverse Leakage | Both RF Outputs Terminated | | -50 | | dBm |
| SSB Phase Noise (100 kHz offset) | $P_{in} = 0$ dBm, $F_{in} = 6$ GHz | | -153 | | dBc/Hz |
| Output Transition Time | $P_{in} = 0$ dBm, $F_{out} = 882$ MHz | | 100 | | ps |
| Supply Current (I_{CC}) | | | 69 | | mA |

1. Divider will operate down to DC for square-wave input signal.



**SMT GaAs HBT MMIC
DIVIDE-BY-3, DC - 7 GHz**

Input Sensitivity Window, $T = 25\text{ }^\circ\text{C}$

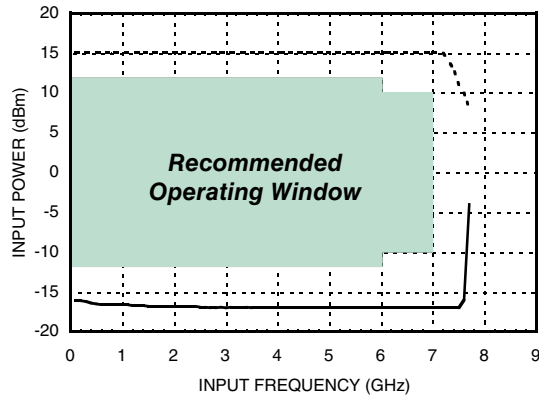

Input Sensitivity Window vs. Temperature

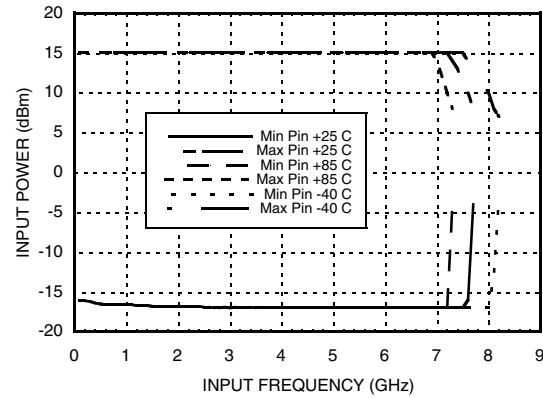

Output Power vs. Temperature

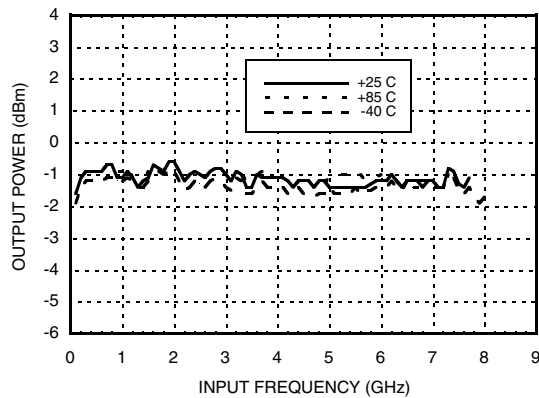

**SSB Phase Noise Performance,
 $P_{in} = 0\text{ dBm}$, $F_{in} = 6\text{ GHz}$, $T = 25\text{ }^\circ\text{C}$**

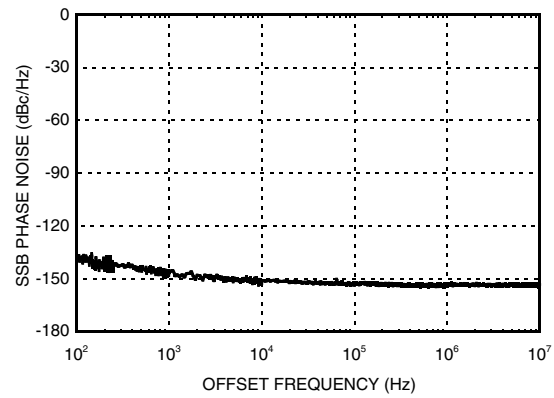

Output Harmonic Content, $P_{in} = 0\text{ dBm}$, $T = 25\text{ }^\circ\text{C}$

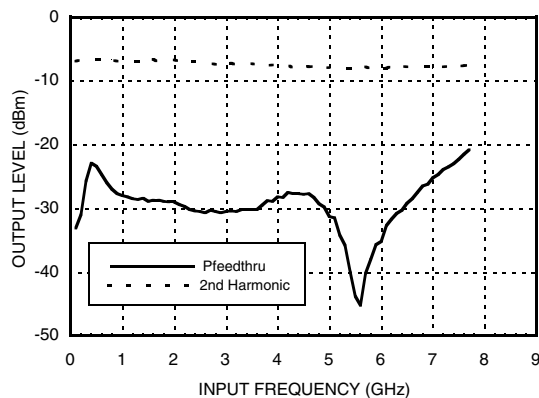

Reverse Leakage, $P_{in} = 0\text{ dBm}$, $T = 25\text{ }^\circ\text{C}$

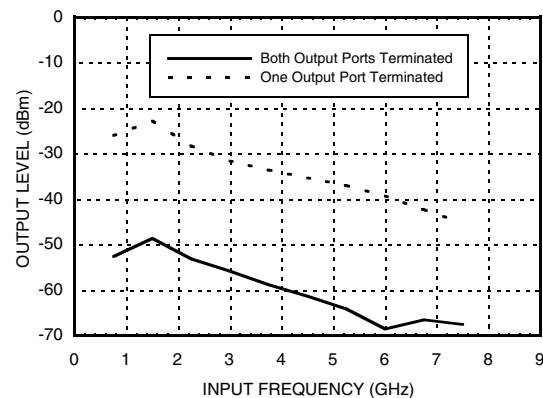

Information furnished by Analog Devices is believed to be accurate and reliable. However, no responsibility is assumed by Analog Devices for its use, nor for any infringements of patents or other rights of third parties that may result from its use. Specifications subject to change without notice. No license is granted by implication or otherwise under any patent or patent rights of Analog Devices. Trademarks and registered trademarks are the property of their respective owners.

For price, delivery, and to place orders: Analog Devices, Inc., One Technology Way, P.O. Box 9106, Norwood, MA 02062-9106 Phone: 781-329-4700 • Order online at www.analog.com Application Support: Phone: 1-800-ANALOG-D



**Output Voltage Waveform,
Pin= 0 dBm, Fout= 882 MHz, T= 25 °C**

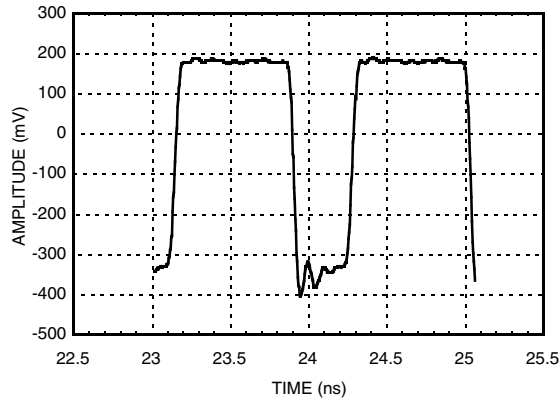

Absolute Maximum Ratings

| | |
|----------------------------|----------------|
| RF Input Power (Vcc = +5V) | 13 dBm |
| Nominal +5V Supply to GND | -0.3V to +5.5V |
| Max Peak Flow Temperature | 260 °C |
| Storage Temperature | -65 to +150 °C |
| ESD Sensitivity (HBM) | Class 1A |

Reliability Information

| | |
|--|---------------|
| Junction Temperature to Maintain 1 Million Hour MTTF | 135 °C |
| Nominal Junction Temperature (T = 85 °C) | 122 °C |
| Thermal Resistance (Junction to GND Paddle, 5V Supply) | 101.5 °C/W |
| Operating Temperature | -40 to +85 °C |

DC blocking capacitors are required at RF input and RF output ports. Choose value for lowest frequency of operation.



**ELECTROSTATIC SENSITIVE DEVICE
OBSERVE HANDLING PRECAUTIONS**

Typical Supply Current vs. Vcc

| Vcc (V) | Icc (mA) |
|---------|----------|
| 4.75 | 64 |
| 5.0 | 69 |
| 5.25 | 75 |

Note: Divider will operate over full voltage range shown above



SMT GaAs HBT MMIC DIVIDE-BY-3, DC - 7 GHz

Outline Drawing

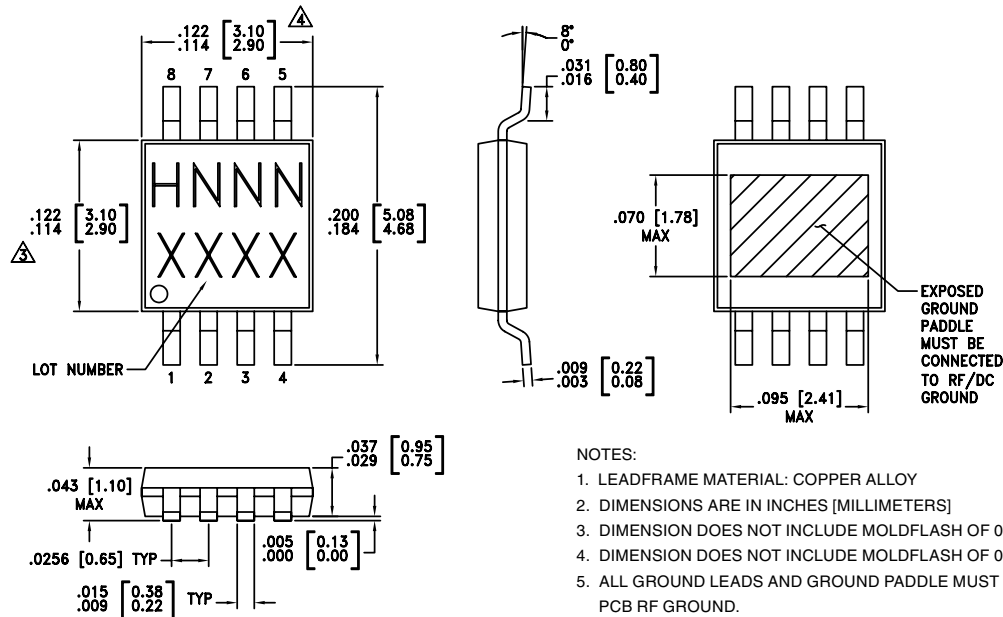

Package Information

| Part Number | Package Body Material | Lead Finish | MSL Rating | Package Marking ^[3] |
|-------------|--|---------------|---------------------|--------------------------------|
| HMC437MS8G | Low Stress Injection Molded Plastic | Sn/Pb Solder | MSL1 ^[1] | H437 XXXX |
| HMC437MS8GE | RoHS-compliant Low Stress Injection Molded Plastic | 100% matte Sn | MSL1 ^[2] | H437 XXXX |

[1] Max peak reflow temperature of 235 °C
 [2] Max peak reflow temperature of 260 °C
 [3] 4-Digit lot number XXXX

Pin Description

| Pin Number | Function | Description | Interface Schematic |
|------------|------------------------|---|---------------------|
| 1 | Vcc | Supply voltage 5V ± 0.25V. | |
| 2 | IN | RF input must be DC blocked. | |
| 3 | $\overline{\text{IN}}$ | RF input 180° out of phase with pin 2 for differential operation. AC ground for single ended operation. | |

Information furnished by Analog Devices is believed to be accurate and reliable. However, no responsibility is assumed by Analog Devices for its use, nor for any infringements of patents or other rights of third parties that may result from its use. Specifications subject to change without notice. No license is granted by implication or otherwise under any patent or patent rights of Analog Devices. Trademarks and registered trademarks are the property of their respective owners.

For price, delivery, and to place orders: Analog Devices, Inc., One Technology Way, P.O. Box 9106, Norwood, MA 02062-9106
 Phone: 781-329-4700 • Order online at www.analog.com
 Application Support: Phone: 1-800-ANALOG-D



**SMT GaAs HBT MMIC
DIVIDE-BY-3, DC - 7 GHz**

Pin Description (Continued)

| Pin Number | Function | Description | Interface Schematic |
|------------|-------------------------|--|---------------------|
| 4, 5 | GND | All ground leads and ground paddle must be soldered to PCB RF/DC ground. | |
| 6 | $\overline{\text{OUT}}$ | Divided output 180° out of phase with pin 7. | |
| 7 | OUT | Divided Output. | |
| 8 | N/C | The pins are not connected internally; however, all data shown herein was measured with these pins connected to RF/DC ground externally. | |

Application Circuit

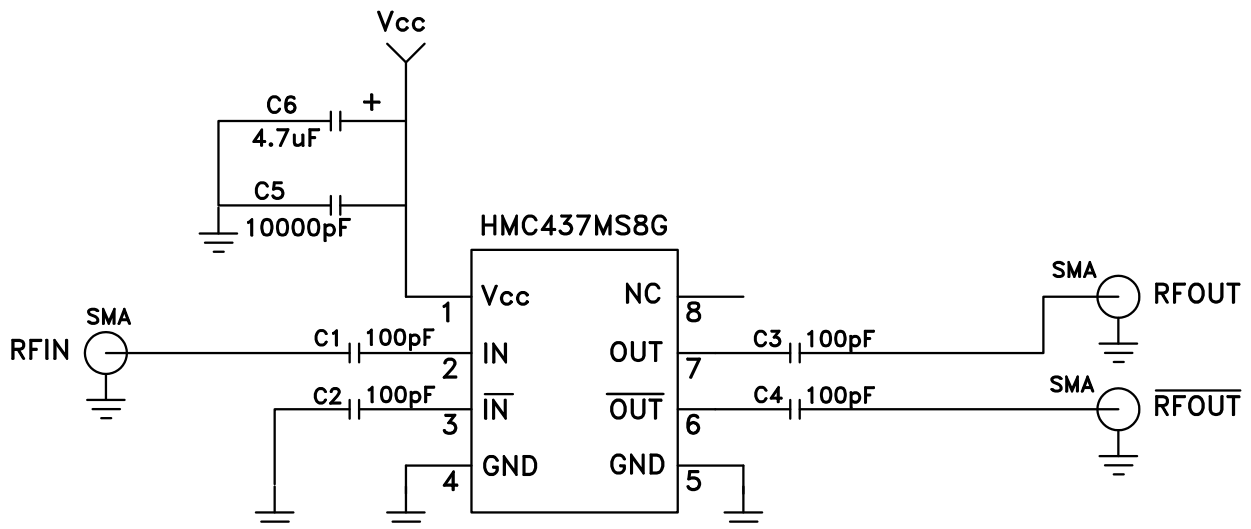

Information furnished by Analog Devices is believed to be accurate and reliable. However, no responsibility is assumed by Analog Devices for its use, nor for any infringements of patents or other rights of third parties that may result from its use. Specifications subject to change without notice. No license is granted by implication or otherwise under any patent or patent rights of Analog Devices. Trademarks and registered trademarks are the property of their respective owners.

For price, delivery, and to place orders: Analog Devices, Inc., One Technology Way, P.O. Box 9106, Norwood, MA 02062-9106 Phone: 781-329-4700 • Order online at www.analog.com Application Support: Phone: 1-800-ANALOG-D



Evaluation PCB

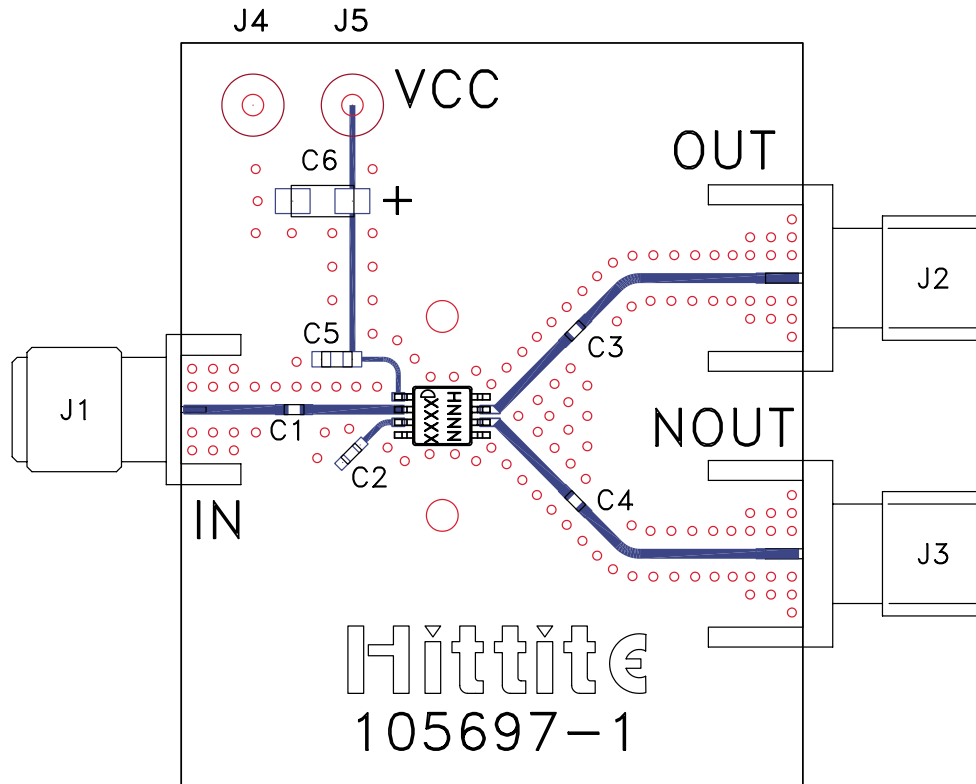

List of Materials for Evaluation PCB 105786 [1]

| Item | Description |
|---------|--------------------------------------|
| J1 - J3 | PCB Mount SMA RF Connector |
| J4, J5 | DC Pin |
| C1 - C4 | 100 pF Capacitor, 0402 Pkg. |
| C5 | 10,000 pF Capacitor, 0603 Pkg. |
| C6 | 4.7 μF Tantalum Capacitor |
| U1 | HMC437MS8G / HMC437MS8GE Divide-by-3 |
| PCB [2] | 105697 Eval Board |

[1] Reference this number when ordering complete evaluation PCB

[2] Circuit Board Material: Rogers 4350

The circuit board used in the application should use RF circuit design techniques. Signal lines should have 50 Ohm impedance while the package ground leads and backside ground slug should be connected directly to the ground plane similar to that shown. A sufficient number of via holes should be used to connect the top and bottom ground planes. The evaluation circuit board shown is available from Hittite upon request. This evaluation board is designed for single ended input testing. J2 and J3 provide differential output signals.

Looking for pricing, stock, or lifecycle information?

Click below to explore more details on WIN SOURCE:

 [View HMC437MS8GE on WIN SOURCE](#)

 [Analog Devices Inc. Information](#)

Optimize Your Supply Chain with WIN SOURCE Solutions

-  Global Sourcing Solution
-  Obsolete Management
-  Cost Control Management
-  Shortage Management
-  Alternative Solution
-  Excess Inventory Management