

TRIPLE 10-BIT 180-MSPS GRAPHICS AND VIDEO DAC

 Check for Samples: [THS8136](#)

FEATURES

- Triple 10-Bit Digital-to-Analog Converters (DACs)
- 180-MSPS Operation
- Direct Drive of Double-Terminated 75-Ω Load Into Standard Video Levels
- Bi-Level Sync and Blank Level Generation
- Internal Voltage Reference
- Low-Power Operation From 3.3-V Analog and 1.8-V Digital Supply Levels
- 1.8-V Compatible Inputs
- Qualified for Automotive Applications (AEC-Q100 Rev G – THS8136IPHPQ1, THS8136IPHPRQ1)

APPLICATIONS

- Graphics and Video Generation
- High-Resolution Image Processing
- Generic Triple D/A Converter

DESCRIPTION

The THS8136 is a general-purpose triple high-speed digital-to-analog (D/A) converter optimized for use in video/graphics applications. The device operates from 3.3-V analog and 1.8-V digital supplies with D/A converter performance assured at sampling rates up to 180 MHz. The THS8136 consists of three 10-bit D/A converters and additional circuitry for bi-level sync and blanking level generation. The current-steering DACs have been specifically designed to produce standard video output levels when directly connected to a single-ended double-terminated 75-Ω coaxial cable.

By providing a dc offset in sync insertion mode, the THS8136 can generate a bi-level sync on the AG DAC output without sacrificing DAC resolution. Support is also provided for insertion of RGB or YPbPr reference or blanking levels, irrespective of the DAC input codes. A generic DAC mode is provided for applications not requiring sync generation. All digital inputs are 1.8-V compatible.

ORDERING INFORMATION⁽¹⁾

T _A	PACKAGED DEVICES ⁽²⁾ PowerPAD™ TQFP-48 – PHP	PACKAGE OPTION
0°C to 70°C	THS8136PHP	Tray
	THS8136PHPR	Tape and reel
–40°C to 85°C	THS8136IPHP	Tray
	THS8136IPHPR	Tape and reel
	THS8136IPHPQ1 ⁽³⁾	Tray
	THS8136IPHPRQ1 ⁽³⁾	Tape and reel

(1) For the most current package and ordering information, see the Package Option Addendum at the end of this document, or see the TI web site at www.ti.com.

(2) Package drawings, thermal data, and symbolization are available at www.ti.com/packaging.

(3) AEC-Q100 Rev G certified



Please be aware that an important notice concerning availability, standard warranty, and use in critical applications of Texas Instruments semiconductor products and disclaimers thereto appears at the end of this data sheet.

PowerPAD is a trademark of Texas Instruments.

**PHP (TQFP-48) PowerPAD PACKAGE
(TOP VIEW)**

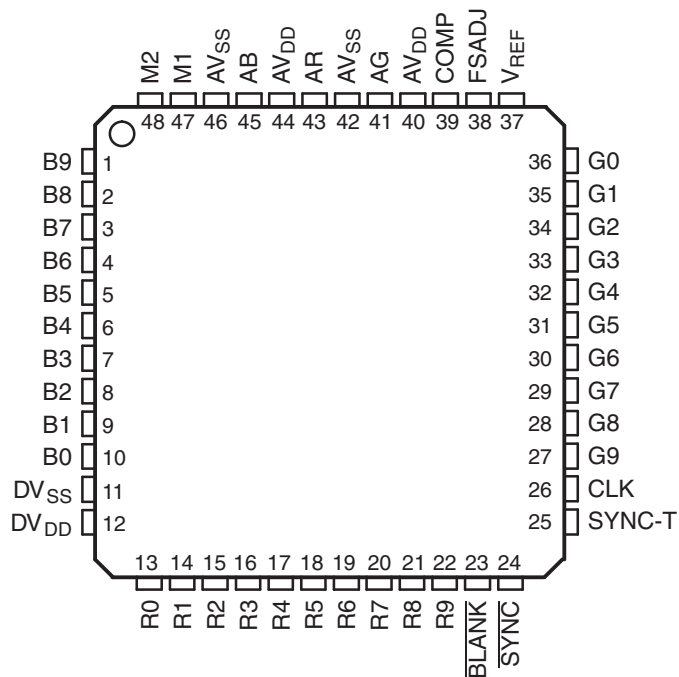

TERMINAL FUNCTIONS

TERMINAL		I/O	DESCRIPTION
NAME	NO.		
AB	45	O	Analog blue current output, capable of directly driving a double terminated 75-Ω coaxial cable
AG	41	O	Analog green current output, capable of directly driving a double terminated 75-Ω coaxial cable
AR	43	O	Analog red current output, capable of directly driving a double terminated 75-Ω coaxial cable
AV _{DD}	40, 44	I	Analog power supply (3.3 V). All AV _{DD} pins must be connected.
AV _{SS}	42, 46	I	Analog ground
$\overline{\text{SYNC}}$	24	I	Sync insertion input. Active low. When asserted, the G output is forced to the bottom sync tip level.
SYNC-T	25	I	Connect to DV _{SS} (GND) or logic low to enable bi-level sync insertion. Connect to DV _{DD} (1.8 V) or logic high for generic DAC applications not requiring sync insertion.
M2	48	I	Connect to DV _{SS} (GND) or logic 0 for RGB blanking level operation. Connect to the $\overline{\text{SYNC}}$ control input for YPbPr video operation.
M1	47	I	Must be tied to DV _{SS} (GND) or logic 0 for normal operation.
B0 B1 B2 B3 B4 B5 B6 B7 B8 B9	10 9 8 7 6 5 4 3 2 1	I	Blue or (Pb) pixel data input. Signals with index 0 denote the least significant bit. Unused inputs should be connected to DV _{SS} (GND).
$\overline{\text{BLANK}}$	23	I	Blanking control input, active low. A rising edge on CLK latches BLANK. When asserted, the AR, AG, and AB outputs are driven to the reference blanking level, regardless of the value on the data inputs.
CLK	26	I	Clock input. A rising edge on CLK latches R0–R9, G0–G9, B0–B9, and BLANK.
COMP	39	O	Compensation terminal. A 0.1-μF capacitor must be connected between COMP and AV _{DD} .
DV _{DD}	12	I	Digital power supply (1.8 V)
DV _{SS}	11	I	Digital ground
FSADJ	38	I	Full-scale adjust control. The full-scale current drive on each of the output channels is determined by the value of a resistor R _{FS} connected between this terminal and AV _{SS} . Figure 3 shows the relationship between full-scale output voltage compliance and R _{FS} for the nominal DAC termination of 37.5 Ω.
G0 G1 G2 G3 G4 G5 G6 G7 G8 G9	36 35 34 33 32 31 30 29 28 27	I	Green (or Y) pixel data input. Signals with index 0 denote the least significant bit. Unused inputs should be connected to DV _{SS} (GND).
R0 R1 R2 R3 R4 R5 R6 R7 R8 R9	13 14 15 16 17 18 19 20 21 22	I	Red (or Pr) pixel data input. Signals with index 0 denote the least significant bit. Unused inputs should be connected to DV _{SS} (GND).
V _{REF}	37	O	Voltage reference for DACs. An internal voltage reference of nominally 1.2 V is provided, which requires an external 0.1-μF ceramic capacitor between V _{REF} and AV _{SS} .

DETAILED DESCRIPTION

The THS8136 is a fast well-matched triple DAC with current outputs optimized for graphics and video applications without sacrificing its usefulness as a generic DAC. The DAC output stages are designed to provide direct drive of doubly-terminated 75- Ω loads (37.5 Ω). The full-scale output current of all three DACs is determined by a single resistor connecting the FSADJ pin to AV_{SS} (GND). A 3.8-k Ω resistor is suitable for most applications requiring 700-mV output levels. Additional circuitry and digital input controls for analog sync and blank level generation are provided for both RGB and YPbPr color spaces. A generic mode of operation is provided for applications not requiring sync insertion. Figure 1 shows a block diagram of the device.

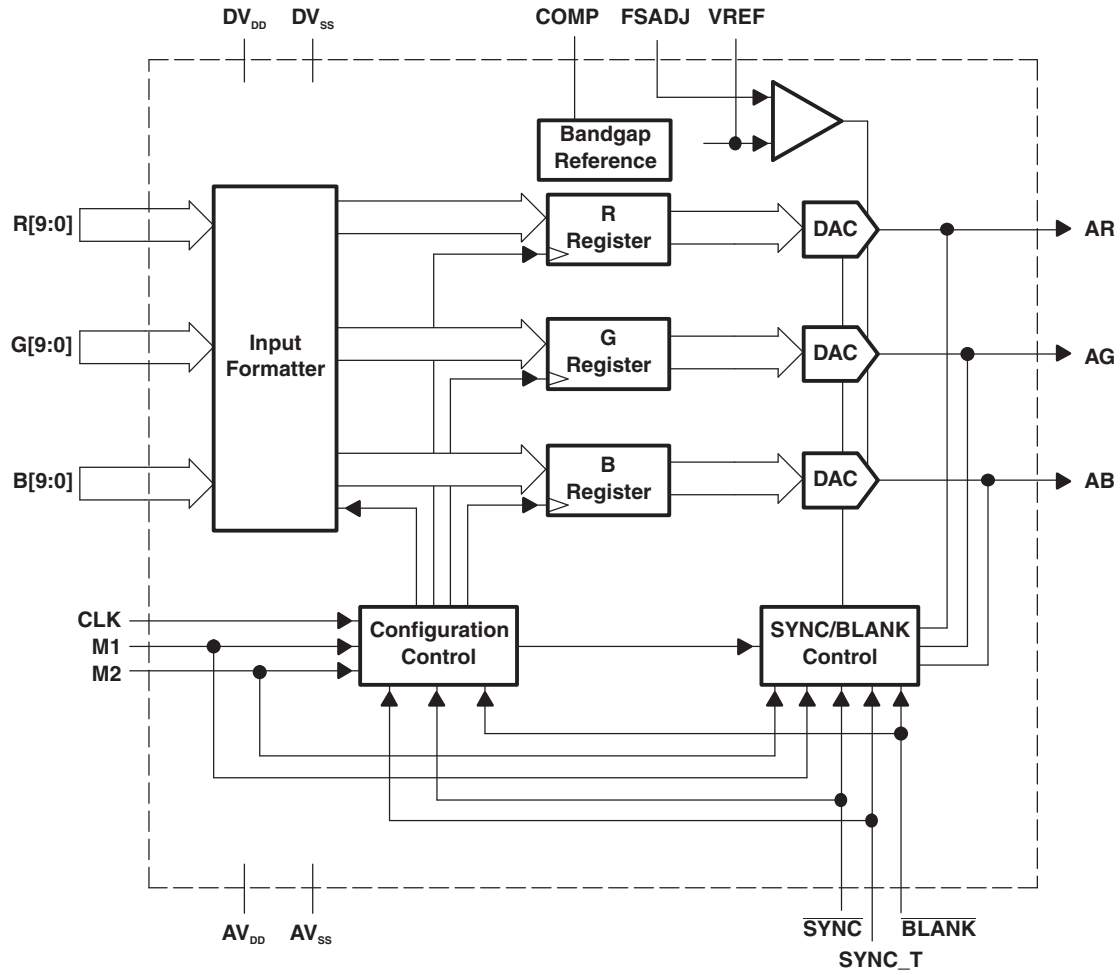

Figure 1. Functional Block Diagram

Generic DAC Mode Versus Sync Insertion Mode

When configured for sync insertion, the THS8136 provides additional dc bias on the DAC outputs to provide headroom for negative bi-level sync insertion. Such bias might be undesirable in applications where no analog sync insertion is required, since it results in additional power consumption and might prevent dc coupling of the DAC outputs. In such cases, only triple DAC operation without dc bias (i.e., DAC input code 0 corresponding to 0-V output) might be preferred. Generic DAC mode is easily selected by connecting the SYNC and SYNC_T pins to DV_{DD} (or logic 1) and the M1 and M2 pins to DV_{SS} (or logic 0). BLANK is functional in both generic mode and sync insertion mode.

Blanking Generation

The $\overline{\text{BLANK}}$ control input forces the output amplitude on all channels to the blanking or reference level, irrespective of the value on the data input ports. The output blanking level on each channel and its relation to active video varies depending on the mode of operation. In generic DAC mode, the output blank level for each DAC is at 0 V and corresponds to a DAC input code of 0. When sync insertion is enabled a 350-mV dc bias (R_{FS} selected for 700-mV output) is applied to provide room for bi-level sync insertion. When RGB sync insertion is enabled, the output blank level of each DAC will be at 350 mV and will correspond to a DAC input code of 0. In YPbPr video mode, the blank level of each DAC is 350 mV, but the AR and AB blank levels correspond to a DAC input code of 512 to accommodate mid-level UV blank levels. A video to blank level amplitude ratio of 2:1 is maintained for various R_{FS} values, provided the maximum DAC output compliance is not exceeded.

Sync Generation

The $\overline{\text{SYNC}}$ and SYNC_T control inputs can be used to enable the superposition of a bi-level sync on the AG DAC output. Correctly timed assertion of the $\overline{\text{SYNC}}$ input (active low) allows insertion of an analog composite sync on the AG DAC output consisting of horizontal sync and vertical sync. The video to sync amplitude ratio is 7:3 providing a 300 mV sync tip, when FSADJ is selected to provide 700 mV full-scale graphics or video. This 7:3 video to sync amplitude ratio is maintained for various R_{FS} values, provided the maximum DAC output compliance is not exceeded. The SYNC-T input pin must be connected to DV_{SS} (or logic low) to enable sync insertion.

Device Configuration

The THS8136 operating mode is determined from the state of the $\overline{\text{SYNC}}$, SYNC-T, M1, and M2 control terminals. Generic DAC mode is easily selected by connecting $\overline{\text{SYNC}}$ and SYNC_T to DV_{DD} (or logic high) and M1 and M2 to DV_{SS} (logic low). To enable sync insertion, the SYNC_T terminal must be connected to DV_{SS} (or logic low). YPbPr video mode can be selected for support of mid-level PbPr blanking by connecting the sync control input to both the $\overline{\text{SYNC}}$ and M2 input terminals. The M1 terminal must be connected to DV_{SS} (logic 0) for all operating modes. See [Table 1](#) and [Figure 4](#), [Figure 5](#), and [Figure 6](#) for additional information on configuring the THS8136.

Table 1. Table 1. Device Configuration

OPERATING MODE	M1	M2	SYNC_T	$\overline{\text{SYNC}}$	DESCRIPTION
Generic DAC	0	0	1	1	Sync insertion disabled. The blank level on all DAC outputs corresponds to 0-V and DAC input code 0.
RGB Sync Insertion	0	0	0	$\overline{\text{SYNC}}$	DC bias and sync insertion enabled. The blank level on all DAC outputs corresponds to DAC input code 0.
YPbPr Sync Insertion	0	$\overline{\text{SYNC}}$	0	$\overline{\text{SYNC}}$	DC bias and sync insertion enabled. AB and AR mid-level blanking corresponds to DAC input code 512.

DAC Operation

The DAC output drivers generate a current with a drive level that can be user-modified by choosing an appropriate resistor value R_{FS} connected between the FSADJ terminal and AV_{SS} (GND). All current source amplitudes (graphics/video, blanking, and sync on AG) are derived from R_{FS} and an internal voltage reference such that the relative amplitudes of sync, blank, and graphics/video are always equal to their nominal relationships. The relative amplitudes of these current drivers are maintained without regard to the value of R_{FS} , as long as the maximum current drive capability is not exceeded. [Figure 3](#) shows the relationship between R_{FS} and the current drive level on each channel for full-range DAC input. The voltage compliance outputs in [Figure 3](#) assume termination with a 37.5-Ω resistor. When sync insertion is enabled, an additional current source is enabled providing a DC bias and head-room for negative sync insertion. A fixed R_{FS} value of 3.8 kΩ ($R_{FS(nom)}$) is suitable for most applications requiring 700-mV output levels.

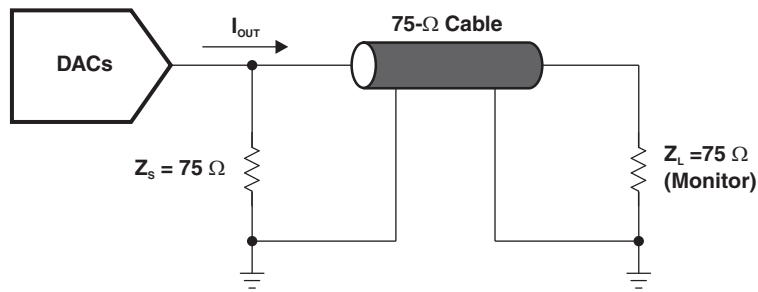

Figure 2. DAC Output Termination

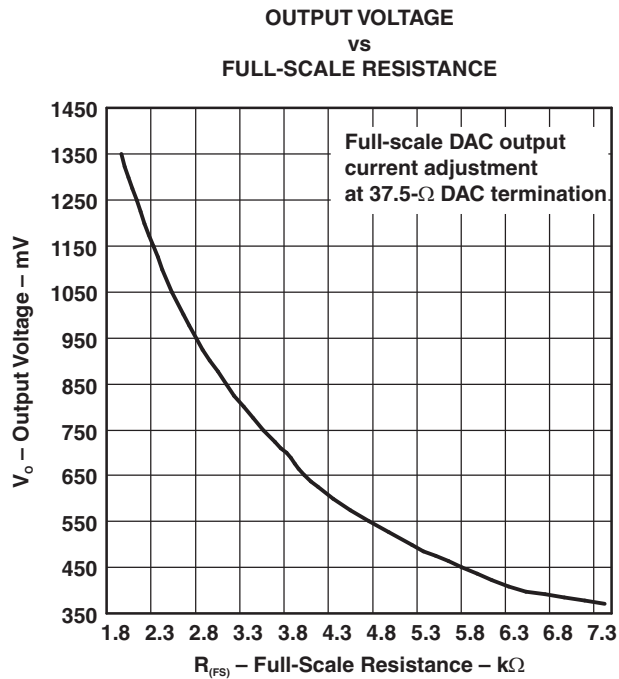
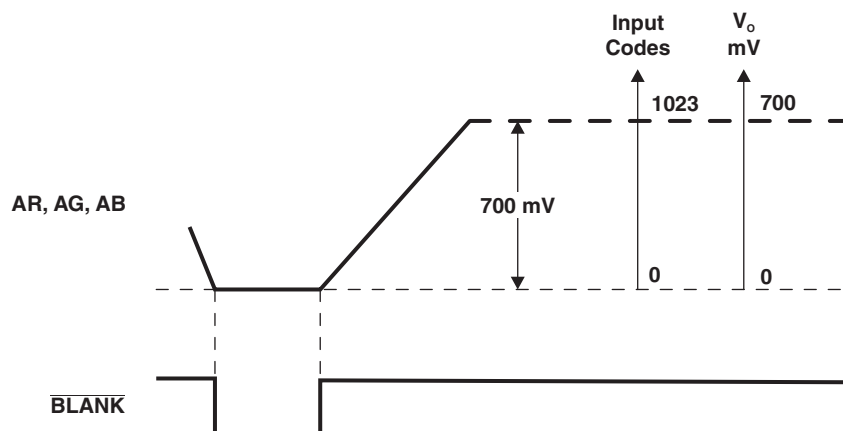

Figure 3. Output Voltage vs Full-Scale Resistance

The user is free to connect another resistor value, but care should be taken not to exceed the maximum current level on each of the DAC outputs as shown in the specifications section. Additionally, DAC output linearity will degrade if the 1.2-V maximum output compliance is exceeded.



NOTE: $\overline{\text{BLANK}}$ = High in applications not requiring a forced blank level.
 R_{FS} chosen for 700-mV output.
 $R_{LOAD} = 37.5 \Omega$

Figure 4. Generic DAC Mode (M1 = Low, M2 = Low, $\overline{\text{SYNC}}$ = High, $\overline{\text{SYNC_T}}$ = High)

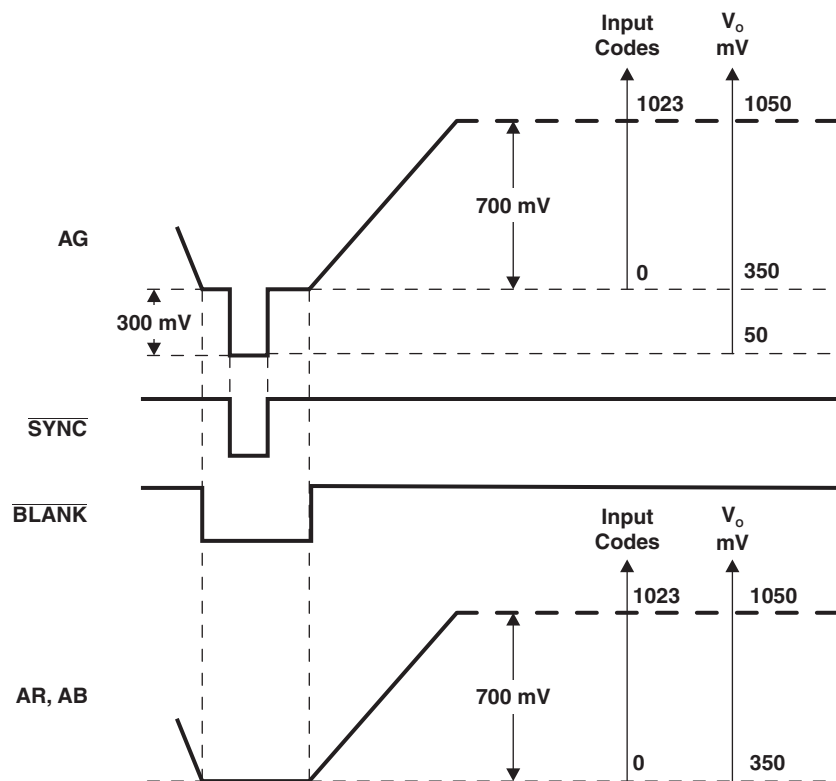

NOTE: R_{FS} chosen for 700-mV output.
 $R_{LOAD} = 37.5 \Omega$

Figure 5. RGB Sync-on-G (M1 = Low, M2 = Low, $\overline{\text{SYNC_T}}$ = Low)

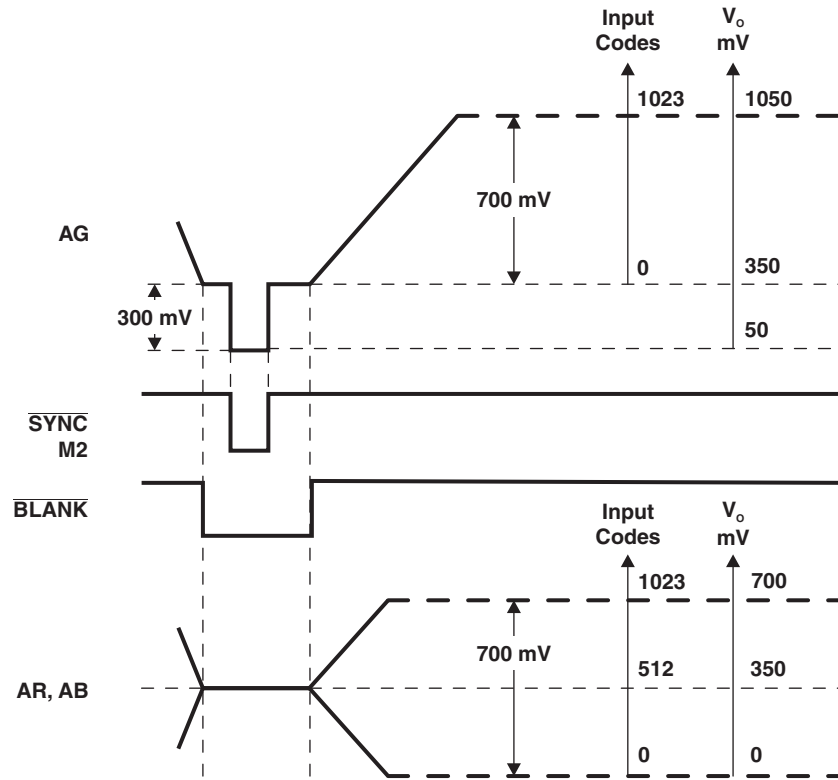

NOTE: R_{FS} chosen for 700-mV output.
R_{LOAD} = 37.5 Ω

Figure 6. YPbPr Sync-on-Y (M1 = Low, M2 = $\overline{\text{SYNC}}$, SYNC_T = Low)

ABSOLUTE MAXIMUM RATINGS⁽¹⁾

over operating free-air temperature range (unless otherwise noted)

Supply voltage	AV _{DD} to AV _{SS}	–0.5 V to 3.6 V	
	DV _{DD} to DV _{SS}	–0.5 V to 1.95 V	
	AV _{SS} to DV _{SS}	–0.5 to 0.5 V	
Digital input voltage range to DV _{SS}		–0.5 V to (DV _{DD} + 0.5) V	
T _A	Operating free-air temperature range	–40°C to 85°C	
T _{stg}	Storage temperature range	–55°C to 150°C	
V _{ESD}	ESD stress voltage ⁽²⁾	Human-body model (HBM) ⁽³⁾ , All pins	>2000 V
		Charged-device model (CDM) ⁽⁴⁾ , All pins	>500 V

- Stresses beyond those listed under *absolute maximum ratings* may cause permanent damage to the device. These are stress ratings only, and functional operation of the device at these or any other conditions beyond those indicated under *recommended operating conditions* is not implied. Exposure to absolute-maximum-rated conditions for extended periods may affect device reliability.
- Electrostatic discharge (ESD) to measure device sensitivity/immunity to damage caused by electrostatic discharges into the device.
- Level listed is the passing level per ANSI/ESDA/JEDEC JS-001-2010 and AEC Q100-002 rev D. JEDEC document JEP155 states that 500-V HBM allows safe manufacturing with a standard ESD control process, and manufacturing with less than 500-V HBM is possible if necessary precautions are taken. Pins listed as 2000 V may actually have higher performance.
- Level listed is the passing level per EIA-JEDEC JESD22-C101E and AEC Q100-011 rev B. JEDEC document JEP157 states that 250-V CDM allows safe manufacturing with a standard ESD control process. Pins listed as 500 V may actually have higher performance. Corner pins meet the AEC Q100-011 rev B 750-V requirement.

THERMAL SPECIFICATIONS

PARAMETER		TEST CONDITIONS ⁽¹⁾	MIN	TYP	MAX	UNIT
θ _{JA}	Junction-to-ambient thermal resistance, still air	Thermal PAD soldered to 4-layer High-K PCB		29.11		°C/W
		Low-K PCB, Thermal PAD not soldered		64.42		°C/W
θ _{JC}	Junction-to-case thermal resistance, still air			0.12		
T _{J(MAX)}	Maximum junction temperature for reliable operation				105	°C

- When split ground planes are used, attach the thermal pad to the analog ground plane.

RECOMMENDED OPERATING CONDITIONS

		MIN	NOM	MAX	UNIT
Power Supply					
AV _{DD}		3	3.3	3.6	V
DV _{DD}		1.65	1.8	1.95	V
Digital and Reference Inputs					
V _{IH}	High-level input voltage	1.2		DV _{DD}	V
V _{IL}	Low-level input voltage	DV _{SS}		0.7	V
f _{CLK}	Clock frequency	0		180	MHz
t _{w(CLKH)}	Pulse duration, clock high	40%		60%	CLK period
t _{w(CLKL)}	Pulse duration, clock low	40%		60%	CLK period
R _{FS(nom)}	FSADJ resistor ⁽¹⁾		3.8		kΩ

- R_{FS} should be chosen such that the maximum full-scale DAC output current (I_{FS}) does not exceed the maximum stated level. This yields the nominal output voltage compliance at the nominal load termination of 37.5 Ω.

POWER SUPPLY ELECTRICAL CHARACTERISTICS

over recommended operating conditions, $f_{CLK} = 180$ MHz, use of internal reference voltage V_{REF} , $R_{FS} = R_{FS(nom)}$, 37.5- Ω load termination (unless otherwise noted)

PARAMETER		TEST CONDITIONS ⁽¹⁾		MIN	TYP ⁽²⁾	MAX ⁽³⁾	UNIT
I_{AVDD}	Operating supply current, analog	CLK = 80 MSPS	Generic (700 mV)		65	72	mA
		CLK = 180 MSPS			65	72	
		CLK = 80 MSPS	Generic (1.2 mV)		110	112	
		CLK = 180 MSPS			110	112	
		CLK = 80 MSPS	Sync Insertion (700 mV + Sync)		94	102	
		CLK = 180 MSPS			94	103	
I_{DVDD}	Operating supply current, digital	CLK = 80 MSPS	Generic (700 mV)		13	16	mA
		CLK = 180 MSPS			31	36	
		CLK = 80 MSPS	Generic (1.2 mV)		14	16	
		CLK = 180 MSPS			31	37	
		CLK = 80 MSPS	Sync Insertion (700 mV + Sync)		13	16	
		CLK = 180 MSPS			31	36	
P_D	Power dissipation	CLK = 80 MSPS	Generic (700 mV)		238	290	mW
		CLK = 180 MSPS			270	329	
		CLK = 80 MSPS	Generic (1.2 mV)		388	434	
		CLK = 180 MSPS			419	475	
		CLK = 80 MSPS	Sync Insertion (700 mV + Sync)		334	398	
		CLK = 180 MSPS			366	441	

(1) A multiburst RGB input test pattern was used in all cases.

(2) TYP current and P_D measured at $AV_{DD} = 3.3$ V and $DV_{DD} = 1.8$ V.

(3) MAX current and P_D measured at $AV_{DD} = 3.6$ V and $DV_{DD} = 1.95$ V.

DIGITAL INPUTS – DC ELECTRICAL CHARACTERISTICS

over recommended operating conditions, $f_{CLK} = 180$ MHz, use of internal reference voltage V_{REF} , $R_{FS} = R_{FS(nom)}$, 37.5- Ω load termination (unless otherwise noted)

PARAMETER		TEST CONDITIONS	MIN	TYP	MAX	UNIT
I_{IH}	High-level input current	$AV_{DD} = 3.3$ V, $DV_{DD} = 1.8$ V, Digital inputs at 1.95 V			1	μ A
I_{IL}	Low-level input current	$AV_{DD} = 3.3$ V, $DV_{DD} = 1.8$ V, Digital inputs at 0 V			-1	μ A
$I_{IH(CLK)}$	High-level input current, CLK	$AV_{DD} = 3.3$ V, $DV_{DD} = 1.8$ V, CLK at 1.95 V	-1		1	μ A
$I_{IL(CLK)}$	Low-level input current, CLK	$AV_{DD} = 3.3$ V, $DV_{DD} = 1.8$ V, CLK at 0 V	-1		1	μ A
C_I	Input capacitance	$T_A = 25^\circ\text{C}$		5		pF
t_s	Setup time, data and control inputs ⁽¹⁾		1.5			ns
t_h	Hold time, data and control inputs ⁽¹⁾		500			ps
$t_{d(D)}$	Digital process delay time from first registered color component of pixel ⁽²⁾			7.5		CLK periods

(1) Specified by characterization only.

(2) This parameter is specified by design. The digital process delay is defined as the number of CLK cycles required for the first registered color component of a pixel, starting from the time of registering it on the input bus, to propagate through all processing and appear at the DAC output drivers. The remaining delay through the IC is the analog delay $t_{d(A)}$ of the analog output drivers.

ANALOG (DAC) OUTPUTS ELECTRICAL CHARACTERISTICS

over recommended operating conditions, $f_{CLK} = 180 \text{ MHz}$, use of internal reference voltage V_{REF} , $R_{FS} = R_{FS(nom)}$, 37.5- Ω load termination (unless otherwise noted)

PARAMETER		TEST CONDITIONS	MIN	TYP	MAX	UNIT
DAC resolution				10		Bits
INL	Integral nonlinearity	Static, best fit, RGB with sync insertion (700 + sync)		-1/1	-2.5/1.5	LSB
		Static, best fit, generic mode, 1.2 V output range		-1/1		
DNL	Differential nonlinearity	Static, RGB with sync insertion (700 + sync)		-0.4/0.4	± 1	LSB
		Static, generic mode, 1.2 V output range		-0.4/0.4		
PSRR	Power supply ripple rejection ratio of DAC output (full scale)	$f = DC^{(1)}$		38.5		dB
V_{refo}	Voltage reference output		1.12	1.16	1.20	V
R_R	V_{REF} output resistance			284		Ω
K_{IMBAL}	Imbalance between DACs ⁽²⁾	CLK = 80 MSPS, video mode	-2	1.8	2	%
V_{OC}	DAC output compliance voltage			0.7	1.2	V
I_{FS}	Generic DAC mode	CLK = 80 MSPS ⁽³⁾	18	18.67	19.5	mA
	RGB with sync insertion enabled	CLK = 80 MSPS ⁽³⁾	27	28	29.3	
t_{RDAC}	DAC output current rise time	CLK = 80 MSPS, 10 to 90% of full scale ⁽⁴⁾	2.8	3.3	3.6	ns
t_{FDAC}	DAC output current fall time	CLK = 80 MSPS, 10 to 90% of full scale ⁽⁴⁾	2.8	3.3	3.6	ns
$t_{d(A)}$	Analog output delay	Measured from CLK = $V_{IH(min)}$ to 50% of full-scale transition ⁽⁵⁾		4.5		ns
t_S	Analog output settling time	Measured from 50% of full scale transition on output to output settling, within 2% ⁽⁴⁾		15		ns

- (1) PSRR is measured with a 0.1- μF capacitor between the COMP and AV_{DD} pins and with a 0.1- μF capacitor connected between the V_{REF} and AV_{SS} pins. The ripple amplitude is within the range 100 mVp-p to 500 mVp-p with the DAC output set to full scale and a double-terminated 75 Ω (= 37.5 Ω) load. PSRR is defined as $20 \times \log(\text{ripple voltage at DAC output}/\text{ripple voltage at } AV_{DD} \text{ input})$. Limits are from characterization only.
- (2) The imbalance between DACs applies to all possible pairs of the three DACs.
- (3) Values at $R_{FS} = R_{FS(nom)}$
- (4) From characterization only. Measured on the AG channel with $R_{FS} = R_{FS(nom)}$.
- (5) This value excludes the digital process delay, $t_{D(D)}$. Limit are from characterization only.

TYPICAL CHARACTERISTICS

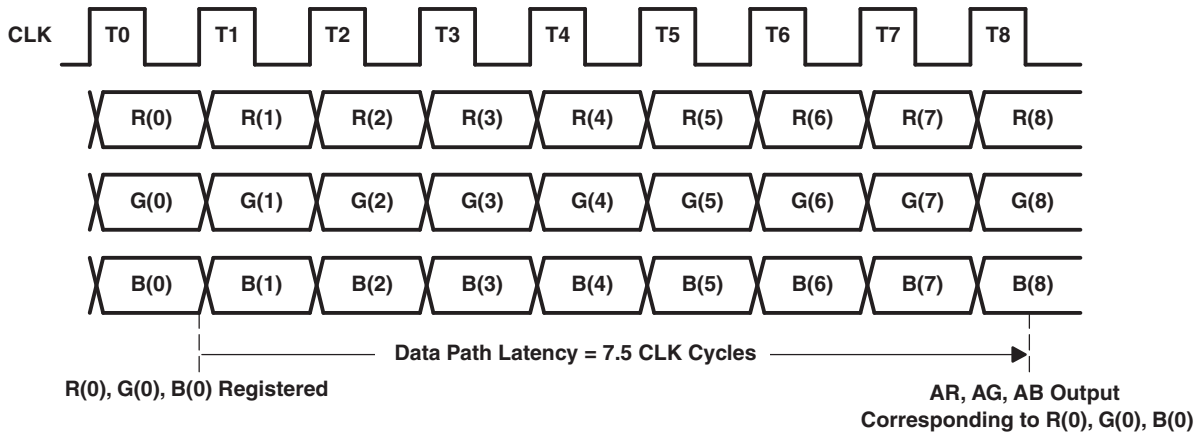

Figure 7. Input Data Internally Latched on Rising Edge of CLK (Data Path Latency is 7.5 CLK Cycles)

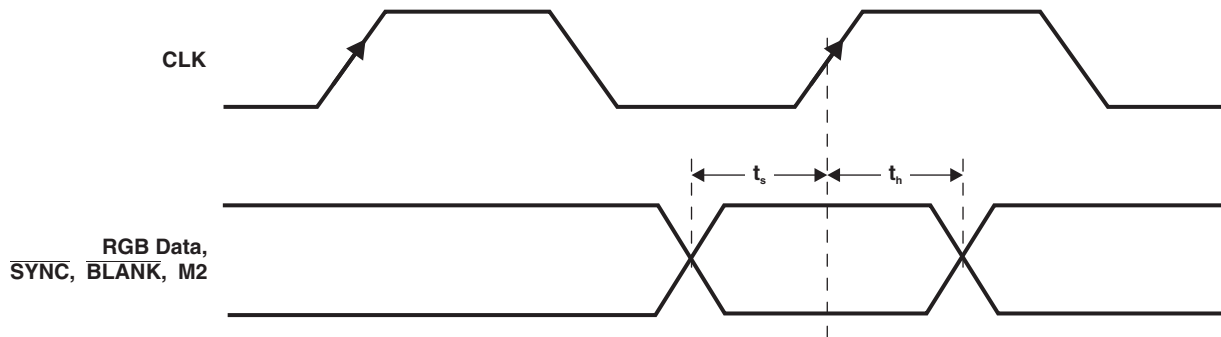

Figure 8. Input Data Registered on Rising Edge of CLK

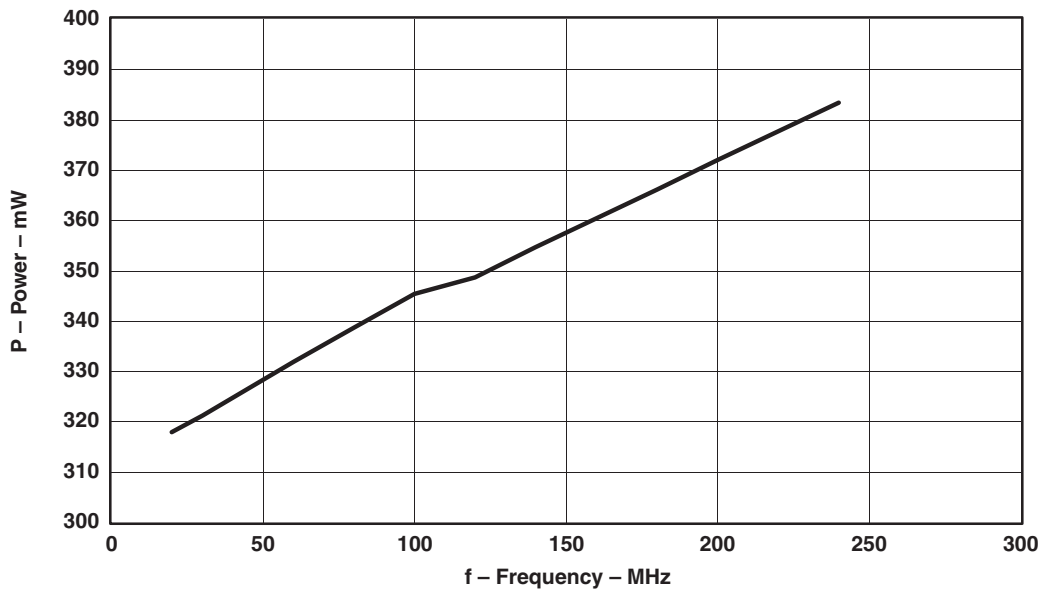
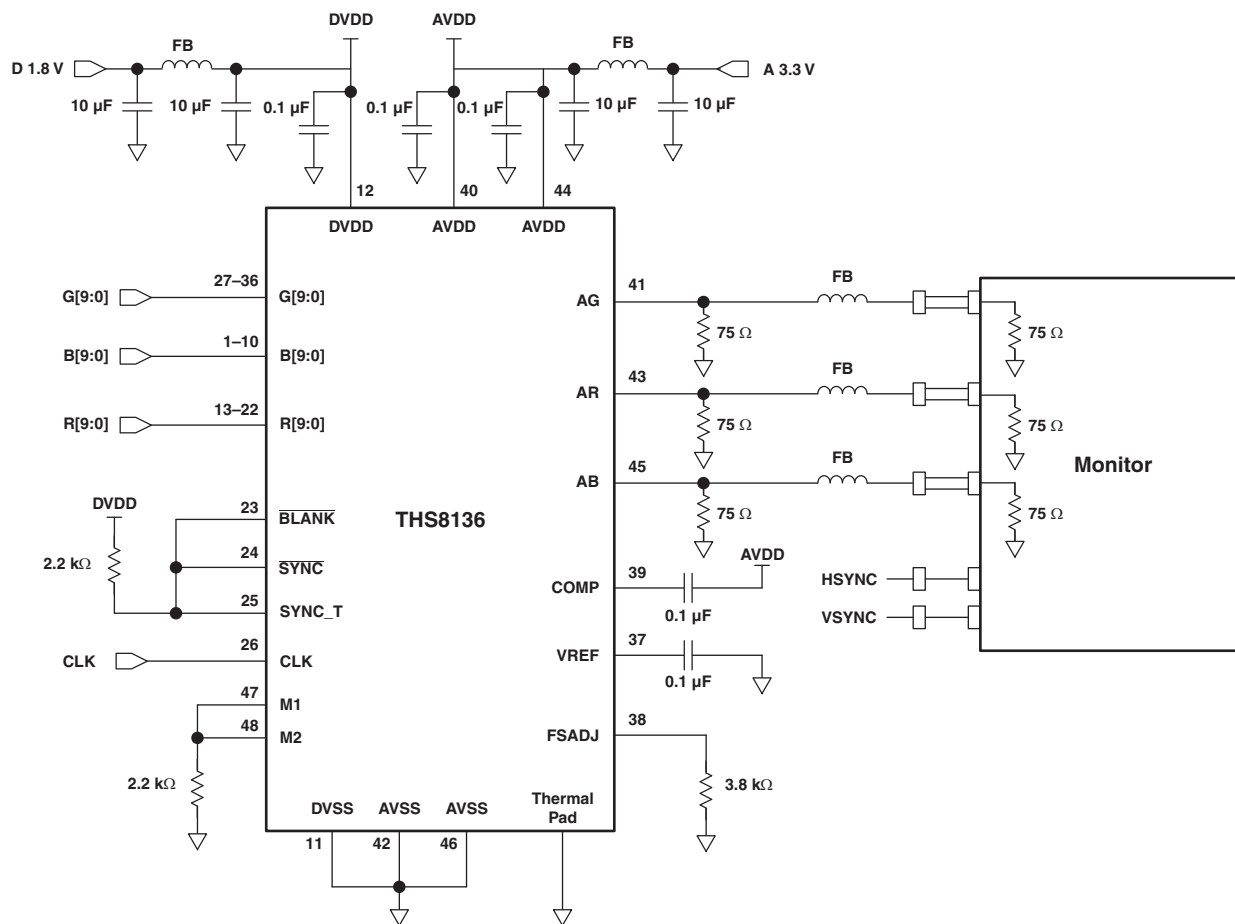

Figure 9. Power vs Clock Frequency, RGB Sync Insertion, 1-MHz Input Tone on All Channels

APPLICATION INFORMATION



NOTE: System level ESD protection is not included in this application circuit, but it is highly recommended on the analog RGB outputs.

Figure 10. Typical Generic DAC Application Circuit

REVISION HISTORY

REVISION	COMMENTS
SLES236	Initial release
SLES236A	AEC-Q100 qualification added. Added ESD data to Absolute Maximum Ratings table. Power dissipation ratings changed to Thermal specifications. Modified Digital inputs - DC electrical characteristics table.
SLES236B	Figure 10 , Added note concerning ESD protection.

PHP (S-PQFP-G48)

PowerPAD™ PLASTIC QUAD FLATPACK

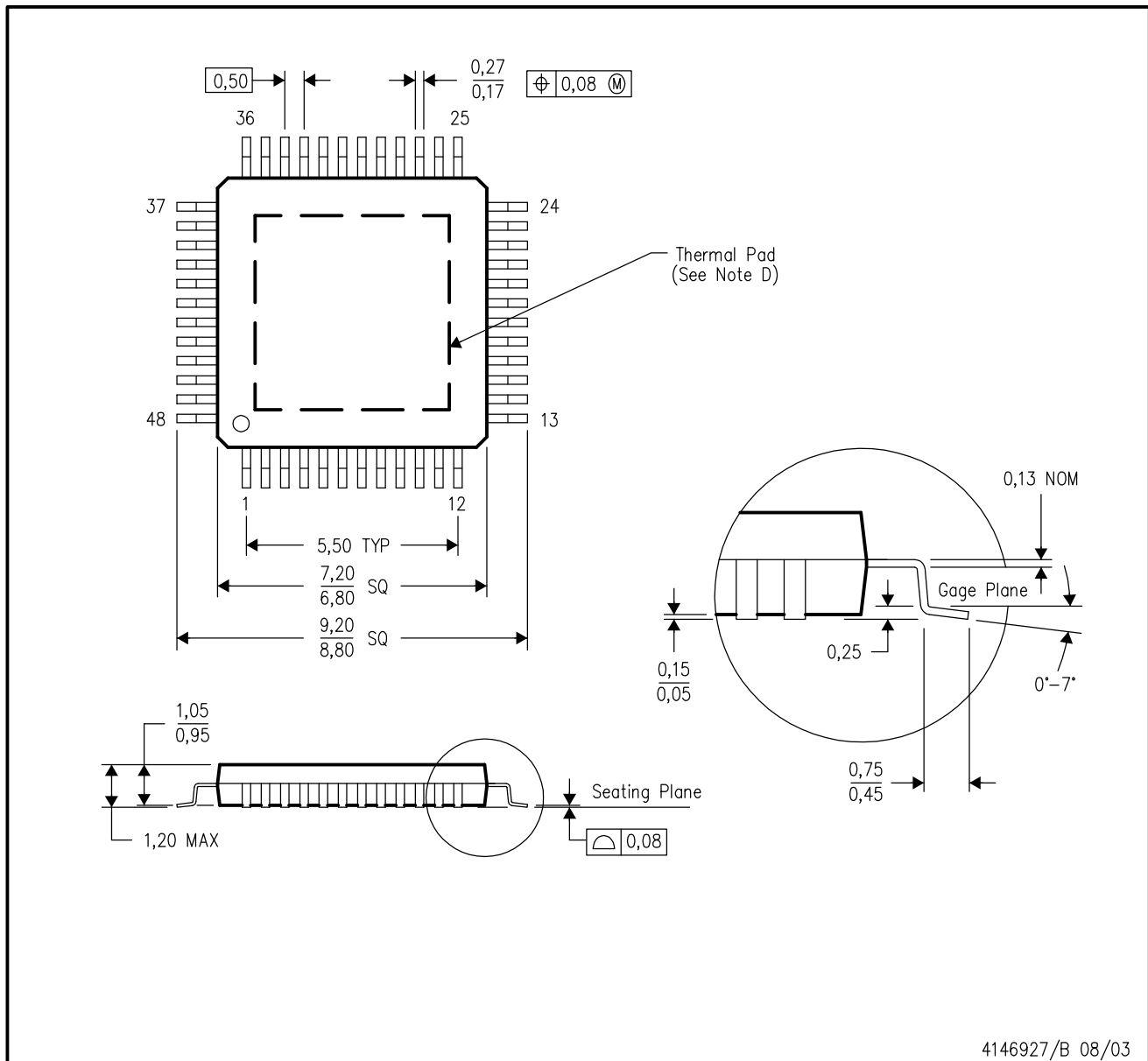

- NOTES:
- All linear dimensions are in millimeters.
 - This drawing is subject to change without notice.
 - Body dimensions do not include mold flash or protrusion.
 - This package is designed to be soldered to a thermal pad on the board. Refer to Technical Brief, PowerPad Thermally Enhanced Package, Texas Instruments Literature No. SLMA002 for information regarding recommended board layout. This document is available at www.ti.com <<http://www.ti.com>>.
 - Falls within JEDEC MS-026

PowerPAD is a trademark of Texas Instruments.

THERMAL PAD MECHANICAL DATA

PHP (S-PQFP-G48)

PowerPAD™ PLASTIC QUAD FLATPACK

THERMAL INFORMATION

This PowerPAD™ package incorporates an exposed thermal pad that is designed to be attached to a printed circuit board (PCB). The thermal pad must be soldered directly to the PCB. After soldering, the PCB can be used as a heatsink. In addition, through the use of thermal vias, the thermal pad can be attached directly to the appropriate copper plane shown in the electrical schematic for the device, or alternatively, can be attached to a special heatsink structure designed into the PCB. This design optimizes the heat transfer from the integrated circuit (IC).

For additional information on the PowerPAD package and how to take advantage of its heat dissipating abilities, refer to Technical Brief, PowerPAD Thermally Enhanced Package, Texas Instruments Literature No. SLMA002 and Application Brief, PowerPAD Made Easy, Texas Instruments Literature No. SLMA004. Both documents are available at www.ti.com.

The exposed thermal pad dimensions for this package are shown in the following illustration.

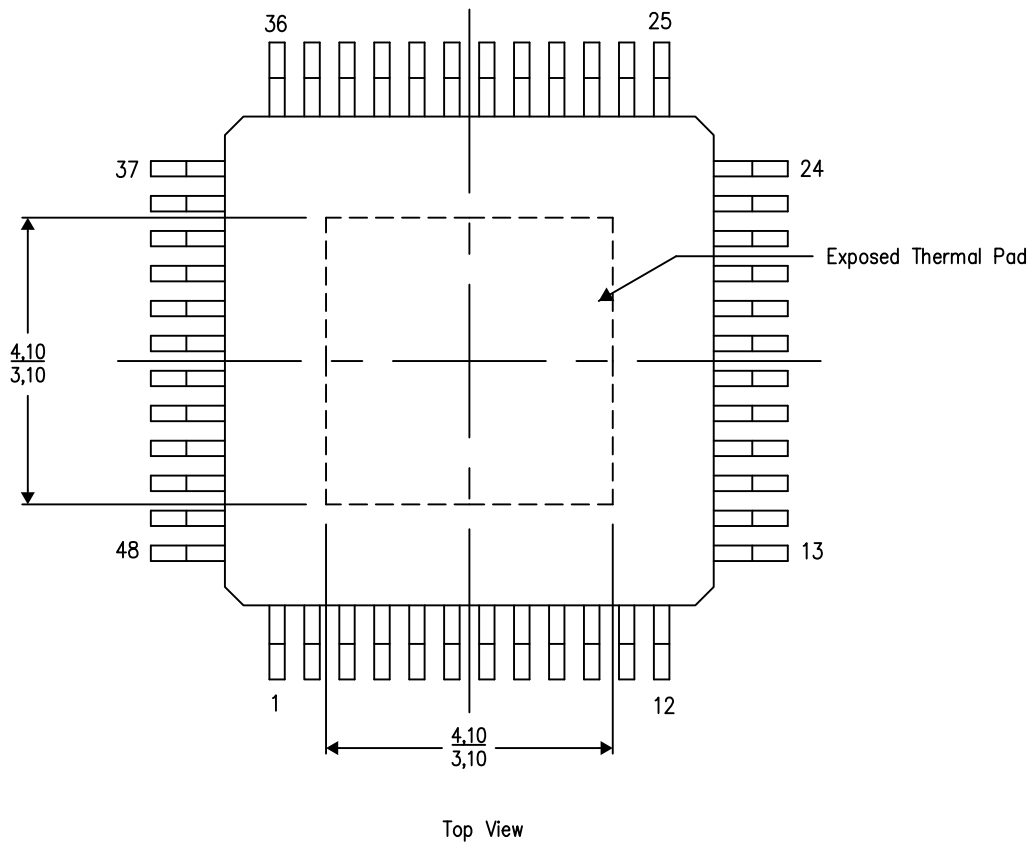

Exposed Thermal Pad Dimensions

4206329-3/P 03/15

NOTE: A. All linear dimensions are in millimeters

PowerPAD is a trademark of Texas Instruments

PHP (S-PQFP-G48)

PowerPAD™ PLASTIC QUAD FLATPACK

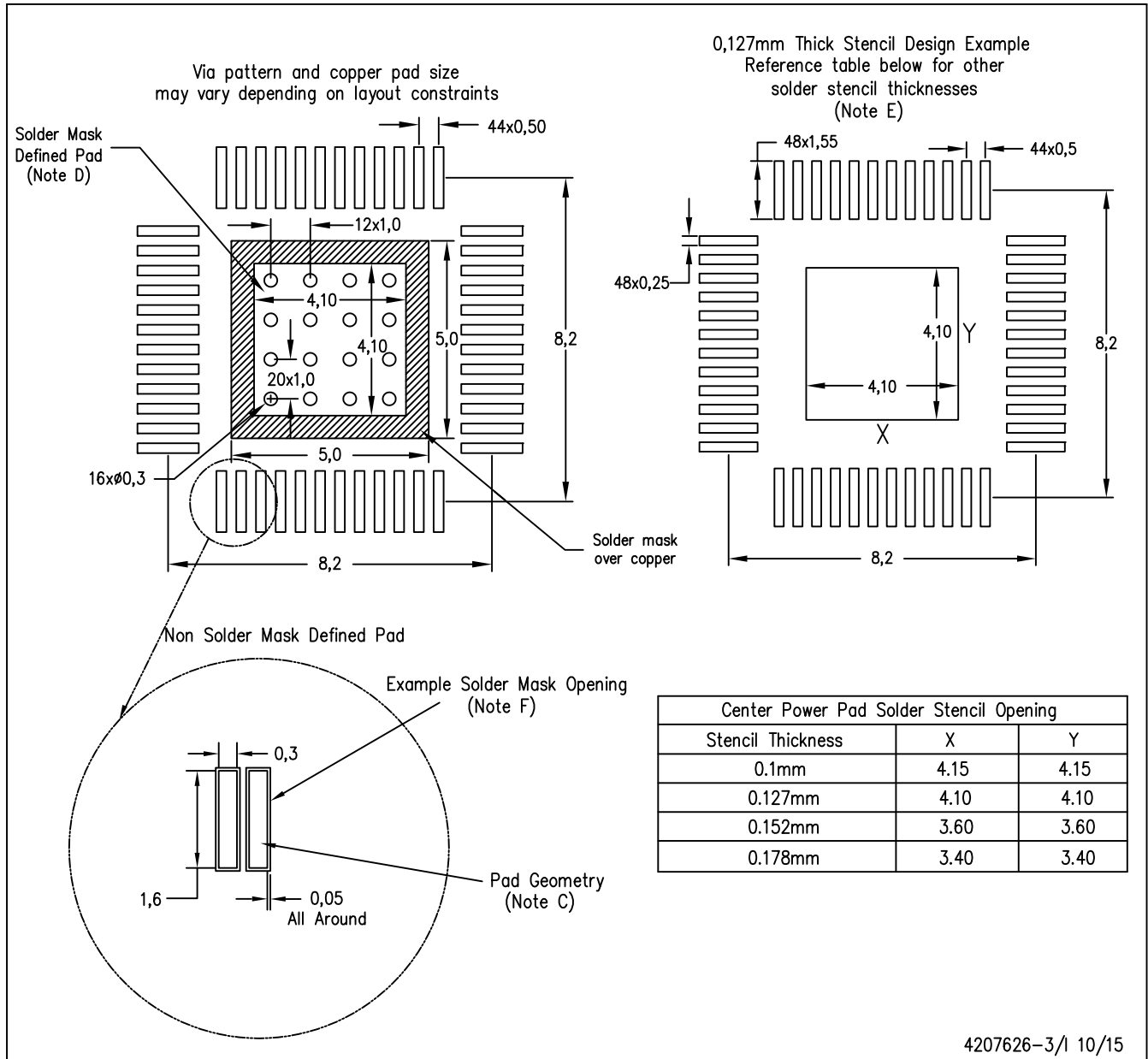

- NOTES:
- A. All linear dimensions are in millimeters.
 - B. This drawing is subject to change without notice.
 - C. Publication IPC-7351 is recommended for alternate designs.
 - D. This package is designed to be soldered to a thermal pad on the board. Refer to Technical Brief, PowerPAD Thermally Enhanced Package, Texas Instruments Literature No. SLMA002, SLMA004, and also the Product Data Sheets for specific thermal information, via requirements, and recommended board layout. These documents are available at www.ti.com <<http://www.ti.com>>.
 - E. Laser cutting apertures with trapezoidal walls and also rounding corners will offer better paste release. Customers should contact their board assembly site for stencil design recommendations. Refer to IPC 7525 for stencil design considerations.
 - F. Customers should contact their board fabrication site for recommended solder mask tolerances and via tenting options for vias placed in the thermal pad.

PowerPAD is a trademark of Texas Instruments

IMPORTANT NOTICE

Texas Instruments Incorporated (TI) reserves the right to make corrections, enhancements, improvements and other changes to its semiconductor products and services per JESD46, latest issue, and to discontinue any product or service per JESD48, latest issue. Buyers should obtain the latest relevant information before placing orders and should verify that such information is current and complete.

TI's published terms of sale for semiconductor products (<http://www.ti.com/sc/docs/stdterms.htm>) apply to the sale of packaged integrated circuit products that TI has qualified and released to market. Additional terms may apply to the use or sale of other types of TI products and services.

Reproduction of significant portions of TI information in TI data sheets is permissible only if reproduction is without alteration and is accompanied by all associated warranties, conditions, limitations, and notices. TI is not responsible or liable for such reproduced documentation. Information of third parties may be subject to additional restrictions. Resale of TI products or services with statements different from or beyond the parameters stated by TI for that product or service voids all express and any implied warranties for the associated TI product or service and is an unfair and deceptive business practice. TI is not responsible or liable for any such statements.

Buyers and others who are developing systems that incorporate TI products (collectively, "Designers") understand and agree that Designers remain responsible for using their independent analysis, evaluation and judgment in designing their applications and that Designers have full and exclusive responsibility to assure the safety of Designers' applications and compliance of their applications (and of all TI products used in or for Designers' applications) with all applicable regulations, laws and other applicable requirements. Designer represents that, with respect to their applications, Designer has all the necessary expertise to create and implement safeguards that (1) anticipate dangerous consequences of failures, (2) monitor failures and their consequences, and (3) lessen the likelihood of failures that might cause harm and take appropriate actions. Designer agrees that prior to using or distributing any applications that include TI products, Designer will thoroughly test such applications and the functionality of such TI products as used in such applications.

TI's provision of technical, application or other design advice, quality characterization, reliability data or other services or information, including, but not limited to, reference designs and materials relating to evaluation modules, (collectively, "TI Resources") are intended to assist designers who are developing applications that incorporate TI products; by downloading, accessing or using TI Resources in any way, Designer (individually or, if Designer is acting on behalf of a company, Designer's company) agrees to use any particular TI Resource solely for this purpose and subject to the terms of this Notice.

TI's provision of TI Resources does not expand or otherwise alter TI's applicable published warranties or warranty disclaimers for TI products, and no additional obligations or liabilities arise from TI providing such TI Resources. TI reserves the right to make corrections, enhancements, improvements and other changes to its TI Resources. TI has not conducted any testing other than that specifically described in the published documentation for a particular TI Resource.

Designer is authorized to use, copy and modify any individual TI Resource only in connection with the development of applications that include the TI product(s) identified in such TI Resource. NO OTHER LICENSE, EXPRESS OR IMPLIED, BY ESTOPPEL OR OTHERWISE TO ANY OTHER TI INTELLECTUAL PROPERTY RIGHT, AND NO LICENSE TO ANY TECHNOLOGY OR INTELLECTUAL PROPERTY RIGHT OF TI OR ANY THIRD PARTY IS GRANTED HEREIN, including but not limited to any patent right, copyright, mask work right, or other intellectual property right relating to any combination, machine, or process in which TI products or services are used. Information regarding or referencing third-party products or services does not constitute a license to use such products or services, or a warranty or endorsement thereof. Use of TI Resources may require a license from a third party under the patents or other intellectual property of the third party, or a license from TI under the patents or other intellectual property of TI.

TI RESOURCES ARE PROVIDED "AS IS" AND WITH ALL FAULTS. TI DISCLAIMS ALL OTHER WARRANTIES OR REPRESENTATIONS, EXPRESS OR IMPLIED, REGARDING RESOURCES OR USE THEREOF, INCLUDING BUT NOT LIMITED TO ACCURACY OR COMPLETENESS, TITLE, ANY EPIDEMIC FAILURE WARRANTY AND ANY IMPLIED WARRANTIES OF MERCHANTABILITY, FITNESS FOR A PARTICULAR PURPOSE, AND NON-INFRINGEMENT OF ANY THIRD PARTY INTELLECTUAL PROPERTY RIGHTS. TI SHALL NOT BE LIABLE FOR AND SHALL NOT DEFEND OR INDEMNIFY DESIGNER AGAINST ANY CLAIM, INCLUDING BUT NOT LIMITED TO ANY INFRINGEMENT CLAIM THAT RELATES TO OR IS BASED ON ANY COMBINATION OF PRODUCTS EVEN IF DESCRIBED IN TI RESOURCES OR OTHERWISE. IN NO EVENT SHALL TI BE LIABLE FOR ANY ACTUAL, DIRECT, SPECIAL, COLLATERAL, INDIRECT, PUNITIVE, INCIDENTAL, CONSEQUENTIAL OR EXEMPLARY DAMAGES IN CONNECTION WITH OR ARISING OUT OF TI RESOURCES OR USE THEREOF, AND REGARDLESS OF WHETHER TI HAS BEEN ADVISED OF THE POSSIBILITY OF SUCH DAMAGES.

Unless TI has explicitly designated an individual product as meeting the requirements of a particular industry standard (e.g., ISO/TS 16949 and ISO 26262), TI is not responsible for any failure to meet such industry standard requirements.

Where TI specifically promotes products as facilitating functional safety or as compliant with industry functional safety standards, such products are intended to help enable customers to design and create their own applications that meet applicable functional safety standards and requirements. Using products in an application does not by itself establish any safety features in the application. Designers must ensure compliance with safety-related requirements and standards applicable to their applications. Designer may not use any TI products in life-critical medical equipment unless authorized officers of the parties have executed a special contract specifically governing such use. Life-critical medical equipment is medical equipment where failure of such equipment would cause serious bodily injury or death (e.g., life support, pacemakers, defibrillators, heart pumps, neurostimulators, and implantables). Such equipment includes, without limitation, all medical devices identified by the U.S. Food and Drug Administration as Class III devices and equivalent classifications outside the U.S.

TI may expressly designate certain products as completing a particular qualification (e.g., Q100, Military Grade, or Enhanced Product). Designers agree that it has the necessary expertise to select the product with the appropriate qualification designation for their applications and that proper product selection is at Designers' own risk. Designers are solely responsible for compliance with all legal and regulatory requirements in connection with such selection.

Designer will fully indemnify TI and its representatives against any damages, costs, losses, and/or liabilities arising out of Designer's non-compliance with the terms and provisions of this Notice.

Looking for pricing, stock, or lifecycle information?

Click below to explore more details on WIN SOURCE:

 [View THS8136PHPR on WIN SOURCE](#)

 [Texas Instruments](#) Information

Optimize Your Supply Chain with WIN SOURCE Solutions

-  Global Sourcing Solution
-  Obsolete Management
-  Cost Control Management
-  Shortage Management
-  Alternative Solution
-  Excess Inventory Management