



**THE DATASHEET OF  
CY7C109D-10VXI**



# 1-Mbit (128 K × 8) Static RAM

## Features

- Pin- and function-compatible with CY7C109B/CY7C1009B
- High speed
  - $t_{AA} = 10 \text{ ns}$
- Low active power
  - $I_{CC} = 80 \text{ mA}$  at 10 ns
- Low CMOS standby power
  - $I_{SB2} = 3 \text{ mA}$
- 2.0 V Data Retention
- Automatic power-down when deselected
- TTL-compatible inputs and outputs
- Easy memory expansion with  $\overline{CE}_1$ ,  $CE_2$  and  $\overline{OE}$  options
- CY7C109D available in Pb-free 32-pin 400-Mil wide Molded SOJ and 32-pin TSOP I packages. CY7C1009D available in Pb-free 32-pin 300-Mil wide Molded SOJ package

## Functional Description

The CY7C109D/CY7C1009D <sup>[1]</sup> is a high-performance CMOS static RAM organized as 131,072 words by 8 bits. Easy memory expansion is provided by an active LOW Chip Enable ( $\overline{CE}_1$ ), an active HIGH Chip Enable ( $CE_2$ ), an active LOW Output Enable ( $\overline{OE}$ ), and tri-state drivers. The eight input and output pins ( $I/O_0$  through  $I/O_7$ ) are placed in a high-impedance state when:

( $\overline{OE}$ ), and tri-state drivers. The eight input and output pins ( $I/O_0$  through  $I/O_7$ ) are placed in a high-impedance state when:

- Deselected ( $\overline{CE}_1$  HIGH or  $CE_2$  LOW),
- Outputs are disabled ( $\overline{OE}$  HIGH),
- When the write operation is active ( $\overline{CE}_1$  LOW,  $CE_2$  HIGH, and  $\overline{WE}$  LOW)

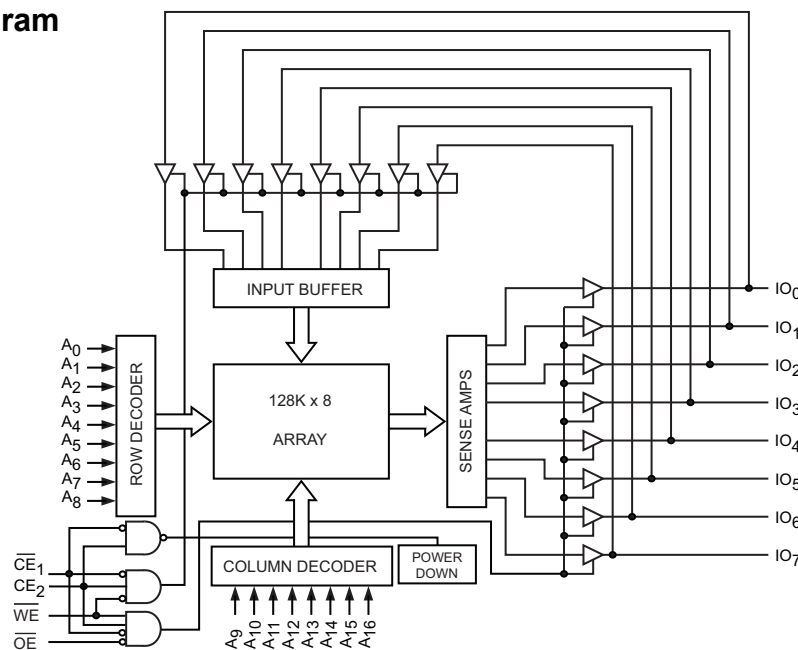
Write to the device by taking Chip Enable One ( $\overline{CE}_1$ ) and Write Enable ( $\overline{WE}$ ) inputs LOW and Chip Enable Two ( $CE_2$ ) input HIGH. Data on the eight I/O pins ( $I/O_0$  through  $I/O_7$ ) is then written into the location specified on the address pins ( $A_0$  through  $A_{16}$ ).

Read from the device by taking Chip Enable One ( $\overline{CE}_1$ ) and Output Enable ( $\overline{OE}$ ) LOW while forcing Write Enable ( $\overline{WE}$ ) and Chip Enable Two ( $CE_2$ ) HIGH. Under these conditions, the contents of the memory location specified by the address pins appears on the I/O pins.

The CY7C109D/CY7C1009D device is suitable for interfacing with processors that have TTL I/P levels. It is not suitable for processors that require CMOS I/P levels. Please see [Electrical Characteristics on page 4](#) for more details and suggested alternatives.

For a complete list of related documentation, click [here](#).

## Logic Block Diagram



## Contents

<b>Pin Configurations</b> .....	<b>3</b>	<b>Ordering Information</b> .....	<b>11</b>
<b>Selection Guide</b> .....	<b>3</b>	Ordering Code Definitions .....	11
<b>Maximum Ratings</b> .....	<b>4</b>	<b>Package Diagrams</b> .....	<b>12</b>
<b>Operating Range</b> .....	<b>4</b>	<b>Acronyms</b> .....	<b>14</b>
<b>Electrical Characteristics</b> .....	<b>4</b>	<b>Document Conventions</b> .....	<b>14</b>
<b>Capacitance</b> .....	<b>5</b>	Units of Measure .....	14
<b>Thermal Resistance</b> .....	<b>5</b>	<b>Document History Page</b> .....	<b>15</b>
<b>AC Test Loads and Waveforms</b> .....	<b>5</b>	<b>Sales, Solutions, and Legal Information</b> .....	<b>16</b>
<b>Data Retention Characteristics</b> .....	<b>6</b>	Worldwide Sales and Design Support .....	16
<b>Data Retention Waveform</b> .....	<b>6</b>	Products .....	16
<b>Switching Characteristics</b> .....	<b>7</b>	PSoC® Solutions .....	16
<b>Switching Waveforms</b> .....	<b>8</b>	Cypress Developer Community .....	16
<b>Truth Table</b> .....	<b>11</b>	Technical Support .....	16

### Note

1. For guidelines on SRAM system design, please refer to the 'System Design Guidelines' Cypress application note, available on the internet at [www.cypress.com](http://www.cypress.com).

## Pin Configurations

Figure 1. 32-pin TSOP I pinout

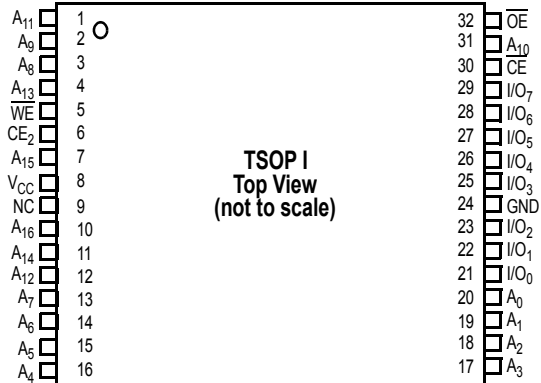
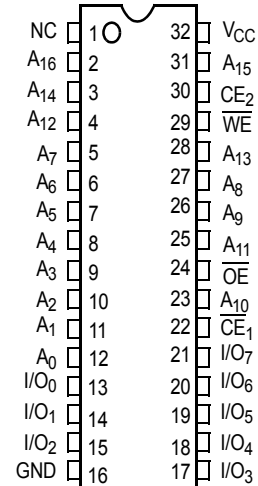


Figure 2. 32-pin SOJ pinout (Top View) <sup>[2]</sup>



## Selection Guide

Description	CY7C109D-10 CY7C1009D-10	Unit
Maximum Access Time	10	ns
Maximum Operating Current	80	mA
Maximum CMOS Standby Current	3	mA

**Note**

2. NC pins are not connected on the die.

## Maximum Ratings

Exceeding maximum ratings may shorten the useful life of the device. User guidelines are not tested.

Storage Temperature .....	-65 °C to +150 °C
Ambient Temperature with Power Applied .....	-55 °C to +125 °C
Supply Voltage on V <sub>CC</sub> to Relative GND [3] .....	-0.5 V to +6.0 V
DC Voltage Applied to Outputs in High-Z State [3] .....	-0.5 V to V <sub>CC</sub> + 0.5 V

DC Input Voltage [3] .....	-0.5 V to V <sub>CC</sub> + 0.5 V
Current into Outputs (LOW) .....	20 mA
Static Discharge Voltage (per MIL-STD-883, Method 3015) .....	> 2001 V
Latch-up Current .....	> 200 mA

## Operating Range

Range	Ambient Temperature	V <sub>CC</sub>	Speed
Industrial	-40 °C to +85 °C	5 V ± 0.5 V	10 ns

## Electrical Characteristics

Over the Operating Range

Parameter	Description	Test Conditions	7C109D-10 7C1009D-10		Unit	
			Min	Max		
V <sub>OH</sub>	Output HIGH Voltage	I <sub>OH</sub> = -4.0 mA	2.4	-	V	
		I <sub>OH</sub> = -0.1 mA	-	3.4 [4]		
V <sub>OL</sub>	Output LOW Voltage	I <sub>OL</sub> = 8.0 mA		0.4	V	
V <sub>IH</sub>	Input HIGH Voltage		2.2	V <sub>CC</sub> + 0.5	V	
V <sub>IL</sub>	Input LOW Voltage [3]		-0.5	0.8	V	
I <sub>IX</sub>	Input Leakage Current	GND ≤ V <sub>I</sub> ≤ V <sub>CC</sub>	-1	+1	μA	
I <sub>OZ</sub>	Output Leakage Current	GND ≤ V <sub>I</sub> ≤ V <sub>CC</sub> , Output Disabled	-1	+1	μA	
I <sub>CC</sub>	V <sub>CC</sub> Operating Supply Current	V <sub>CC</sub> = Max, I <sub>OUT</sub> = 0 mA, f = f <sub>max</sub> = 1/t <sub>RC</sub>	100 MHz	-	80	mA
			83 MHz	-	72	mA
			66 MHz	-	58	mA
			40 MHz	-	37	mA
I <sub>SB1</sub>	Automatic CE Power-Down Current – TTL Inputs	Max V <sub>CC</sub> , $\overline{CE}_1 \geq V_{IH}$ or CE <sub>2</sub> ≤ V <sub>IL</sub> , V <sub>IN</sub> ≥ V <sub>IH</sub> or V <sub>IN</sub> ≤ V <sub>IL</sub> , f = f <sub>max</sub>	-	10	mA	
I <sub>SB2</sub>	Automatic CE Power-Down Current – CMOS Inputs	Max V <sub>CC</sub> , $\overline{CE}_1 \geq V_{CC} - 0.3$ V, or CE <sub>2</sub> ≤ 0.3 V, V <sub>IN</sub> ≥ V <sub>CC</sub> - 0.3 V, or V <sub>IN</sub> ≤ 0.3 V, f = 0	-	3	mA	

### Note

- V<sub>IL</sub> (min) = -2.0 V and V<sub>IH</sub>(max) = V<sub>CC</sub> + 1 V for pulse durations of less than 5 ns.
- Please note that the maximum V<sub>OH</sub> limit does not exceed minimum CMOS V<sub>IH</sub> of 3.5 V. If you are interfacing this SRAM with 5 V legacy processors that require a minimum V<sub>IH</sub> of 3.5 V, please refer to Application Note AN6081 for technical details and options you may consider.

## Capacitance

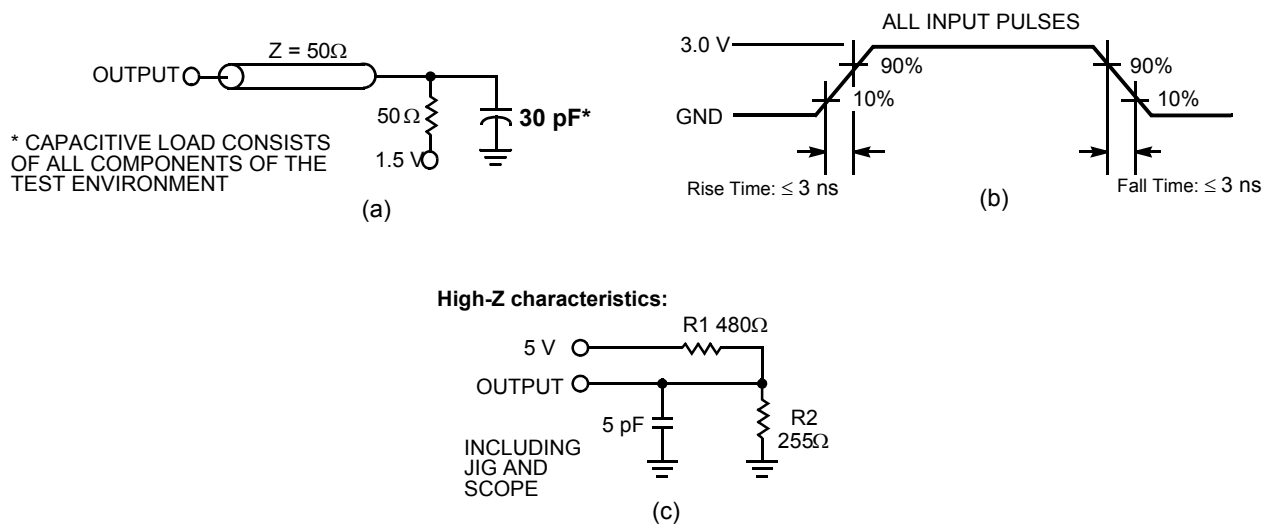
Parameter <sup>[5]</sup>	Description	Test Conditions	Max	Unit
C <sub>IN</sub>	Input capacitance	T <sub>A</sub> = 25 °C, f = 1 MHz, V <sub>CC</sub> = 5.0 V	8	pF
C <sub>OUT</sub>	Output capacitance		8	pF

## Thermal Resistance

Parameter <sup>[5]</sup>	Description	Test Conditions	300-Mil Wide SOJ	400-Mil Wide SOJ	TSOP I	Unit
Θ <sub>JA</sub>	Thermal resistance (junction to ambient)	Still Air, soldered on a 3 × 4.5 inch, four-layer printed circuit board	57.61	56.29	50.72	°C/W
Θ <sub>JC</sub>	Thermal resistance (junction to case)		40.53	38.14	16.21	°C/W

## AC Test Loads and Waveforms

Figure 3. AC Test Loads and Waveforms <sup>[6]</sup>



### Notes

- Tested initially and after any design or process changes that may affect these parameters.
- AC characteristics (except High-Z) are tested using the load conditions shown in Figure 3 (a). High-Z characteristics are tested for all speeds using the test load shown in Figure 3 (c).

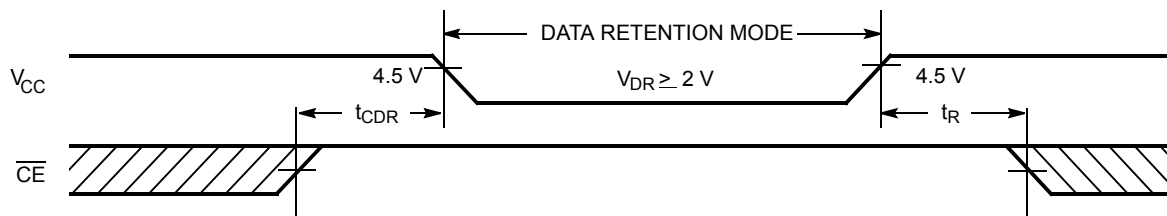
## Data Retention Characteristics

Over the Operating Range

Parameter	Description	Conditions	Min	Max	Unit
$V_{DR}$	$V_{CC}$ for Data Retention	$V_{CC} = V_{DR} = 2.0\text{ V}$ ,	2.0	–	V
$I_{CCDR}$	Data Retention Current	$CE_1 \geq V_{CC} - 0.3\text{ V}$ or $CE_2 \leq 0.3\text{ V}$ , $V_{IN} \geq V_{CC} - 0.3\text{ V}$ or $V_{IN} \leq 0.3\text{ V}$	–	3	mA
$t_{CDR}^{[7]}$	Chip Deselect to Data Retention Time		0	–	ns
$t_R^{[8]}$	Operation Recovery Time		$t_{RC}$	–	ns

## Data Retention Waveform

Figure 4. Data Retention Waveform



### Notes

7. Tested initially and after any design or process changes that may affect these parameters.
8. Full device operation requires linear  $V_{CC}$  ramp from  $V_{DR}$  to  $V_{CC(min)} \geq 50\ \mu\text{s}$  or stable at  $V_{CC(min)} \geq 50\ \mu\text{s}$ .

## Switching Characteristics

Over the Operating Range

Parameter <sup>[9]</sup>	Description	7C109D-10 7C1009D-10		Unit
		Min	Max	
<b>Read Cycle</b>				
$t_{power}^{[10]}$	$V_{CC}$ (typical) to the first access	100	–	$\mu$ s
$t_{RC}$	Read Cycle Time	10	–	ns
$t_{AA}$	Address to Data Valid	–	10	ns
$t_{OHA}$	Data Hold from Address Change	3	–	ns
$t_{ACE}$	$\overline{CE}_1$ LOW to Data Valid, $CE_2$ HIGH to Data Valid	–	10	ns
$t_{DOE}$	$\overline{OE}$ LOW to Data Valid	–	5	ns
$t_{LZOE}$	$\overline{OE}$ LOW to Low Z	0	–	ns
$t_{HZOE}$	$\overline{OE}$ HIGH to High Z <sup>[11, 12]</sup>	–	5	ns
$t_{LZCE}$	$\overline{CE}_1$ LOW to Low Z, $CE_2$ HIGH to Low Z <sup>[12]</sup>	3	–	ns
$t_{HZCE}$	$\overline{CE}_1$ HIGH to High Z, $CE_2$ LOW to High Z <sup>[11, 12]</sup>	–	5	ns
$t_{PU}^{[13]}$	$\overline{CE}_1$ LOW to Power-Up, $CE_2$ HIGH to Power-Up	0	–	ns
$t_{PD}^{[13]}$	$\overline{CE}_1$ HIGH to Power-Down, $CE_2$ LOW to Power-Down	–	10	ns
<b>Write Cycle <sup>[14, 15]</sup></b>				
$t_{WC}$	Write Cycle Time	10	–	ns
$t_{SCE}$	$\overline{CE}_1$ LOW to Write End, $CE_2$ HIGH to Write End	7	–	ns
$t_{AW}$	Address Set-Up to Write End	7	–	ns
$t_{HA}$	Address Hold from Write End	0	–	ns
$t_{SA}$	Address Set-Up to Write Start	0	–	ns
$t_{PWE}$	$\overline{WE}$ Pulse Width	7	–	ns
$t_{SD}$	Data Set-Up to Write End	6	–	ns
$t_{HD}$	Data Hold from Write End	0	–	ns
$t_{LZWE}$	$\overline{WE}$ HIGH to Low Z <sup>[12]</sup>	3	–	ns
$t_{HZWE}$	$\overline{WE}$ LOW to High Z <sup>[11, 12]</sup>	–	5	ns

### Notes

9. Test conditions assume signal transition time of 3 ns or less, timing reference levels of 1.5 V, input pulse levels of 0 to 3.0 V, and output loading of the specified  $I_{OL}/I_{OH}$  and 30-pF load capacitance.
10.  $t_{POWER}$  gives the minimum amount of time that the power supply should be at typical  $V_{CC}$  values until the first memory access can be performed.
11.  $t_{HZOE}$ ,  $t_{HZCE}$  and  $t_{HZWE}$  are specified with a load capacitance of 5 pF as in part (c) of Figure 3 on page 5. Transition is measured when the outputs enter a high impedance state.
12. At any given temperature and voltage condition,  $t_{HZCE}$  is less than  $t_{LZCE}$ ,  $t_{HZOE}$  is less than  $t_{LZOE}$ , and  $t_{HZWE}$  is less than  $t_{LZWE}$  for any given device.
13. This parameter is guaranteed by design and is not tested.
14. The internal write time of the memory is defined by the overlap of  $\overline{CE}_1$  LOW,  $CE_2$  HIGH, and  $\overline{WE}$  LOW.  $\overline{CE}_1$  and  $\overline{WE}$  must be LOW and  $CE_2$  HIGH to initiate a write, and the transition of any of these signals can terminate the write. The input data set-up and hold timing should be referenced to the leading edge of the signal that terminates the write.
15. The minimum write cycle time for Write Cycle No. 3 ( $\overline{WE}$  controlled,  $\overline{OE}$  LOW) is the sum of  $t_{HZWE}$  and  $t_{SD}$ .

## Switching Waveforms

Figure 5. Read Cycle No. 1 (Address Transition Controlled) [16, 17]

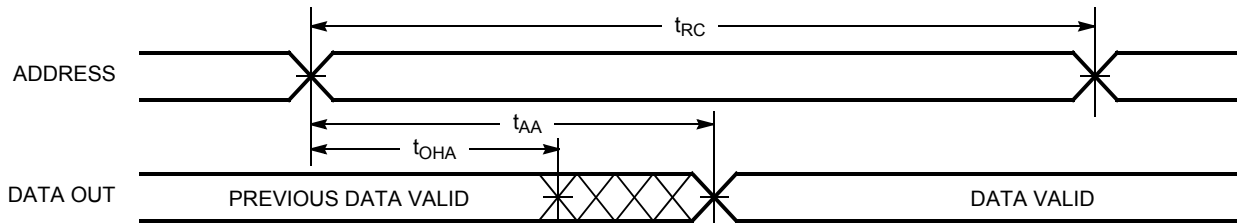
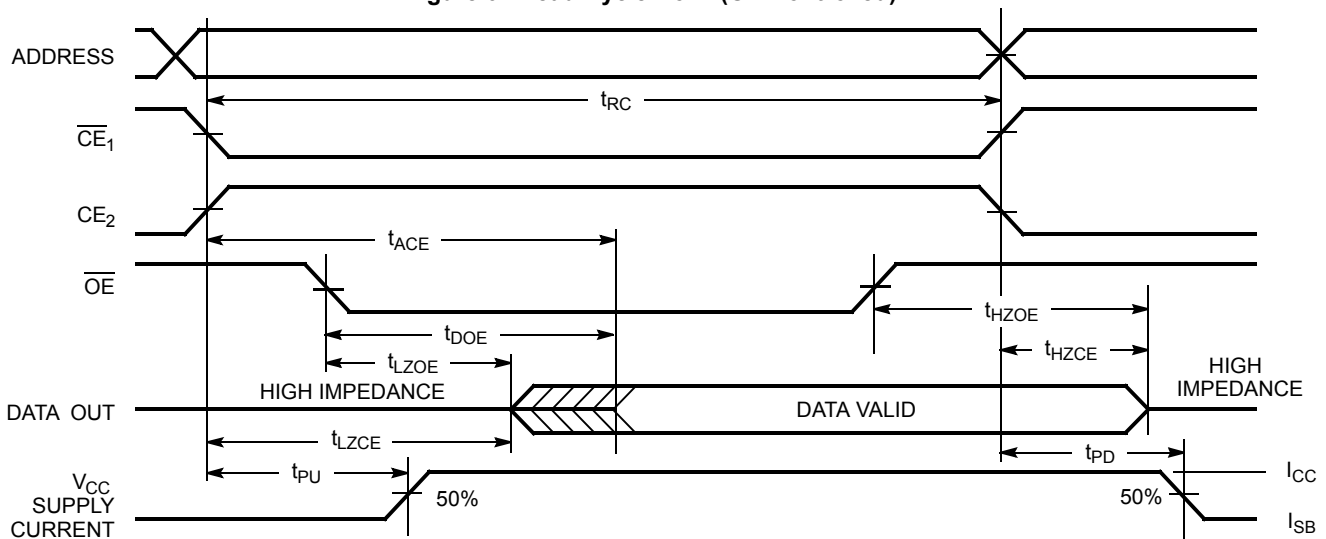


Figure 6. Read Cycle No. 2 ( $\overline{OE}$  Controlled) [17, 18]



### Notes

16. Device is continuously selected.  $\overline{OE}$ ,  $\overline{CE}_1 = V_{IL}$ ,  $CE_2 = V_{IH}$ .
17.  $\overline{WE}$  is HIGH for read cycle.
18. Address valid prior to or coincident with  $\overline{CE}_1$  transition LOW and  $CE_2$  transition HIGH.

Switching Waveforms (continued)

Figure 7. Write Cycle No. 1 ( $\overline{CE}_1$  or  $CE_2$  Controlled) [19, 20]

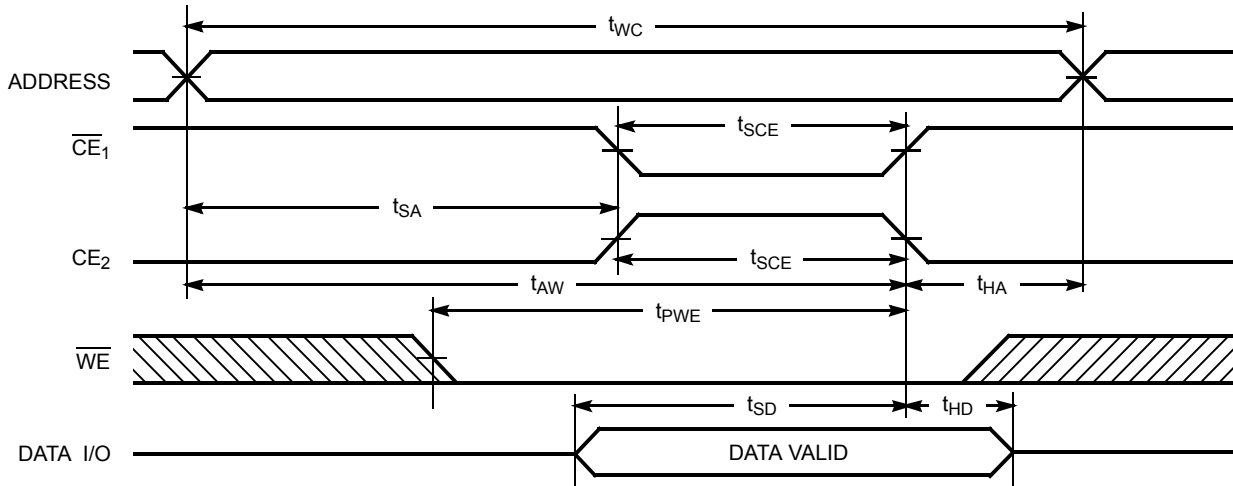
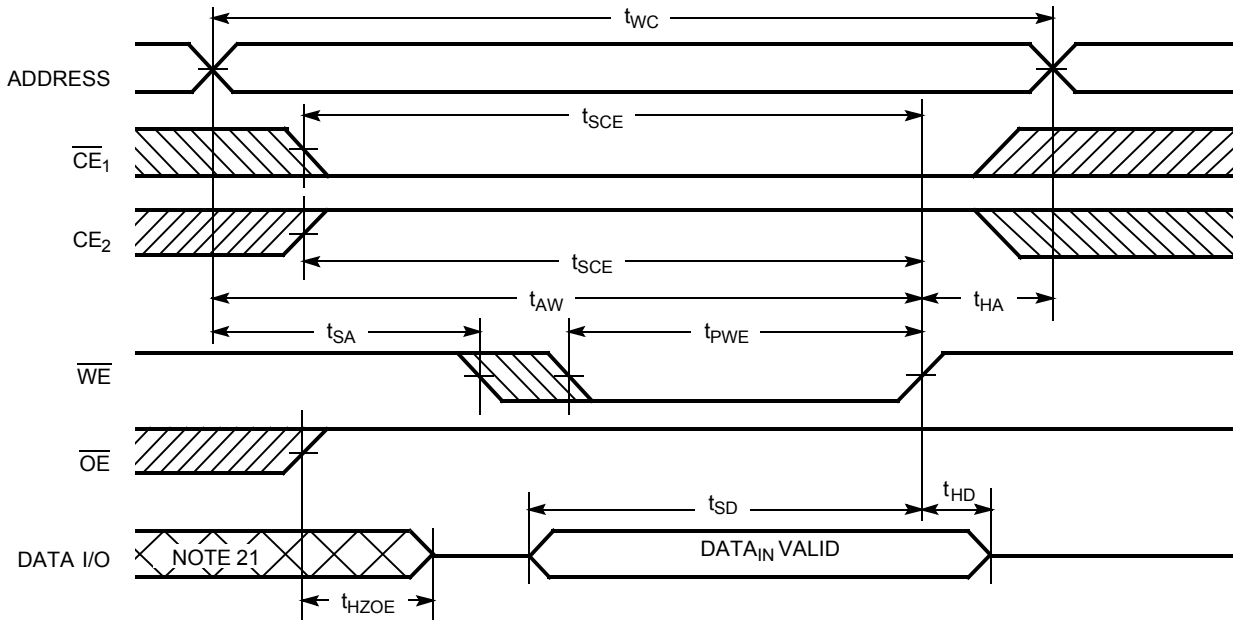


Figure 8. Write Cycle No. 2 ( $\overline{WE}$  Controlled,  $\overline{OE}$  HIGH During Write) [19, 20]

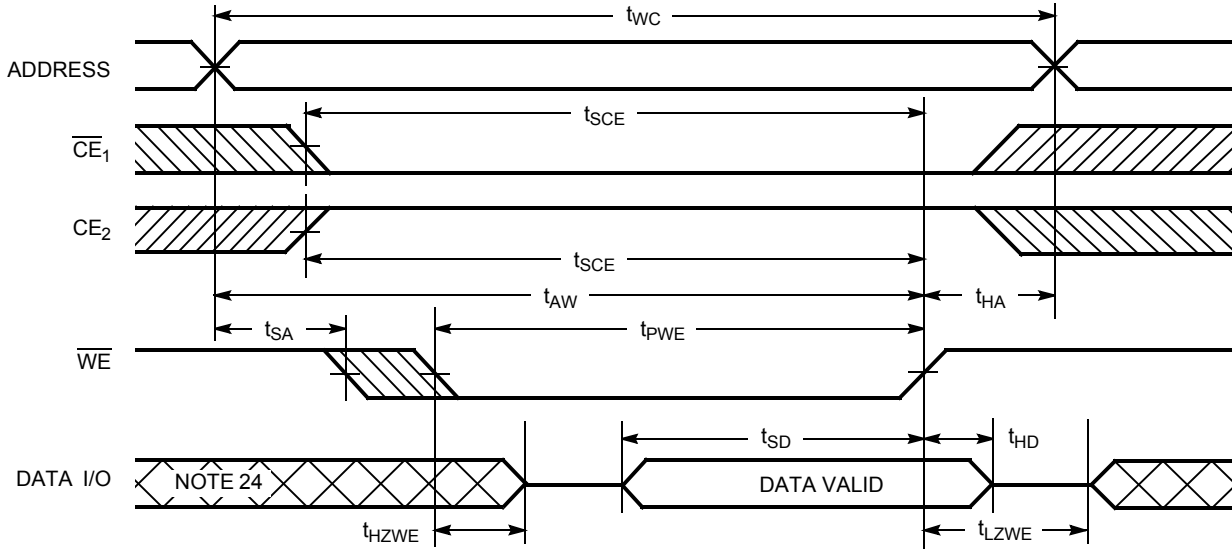


Notes

- 19. Data I/O is high impedance if  $\overline{OE} = V_{IH}$ .
- 20. If  $\overline{CE}_1$  goes HIGH or  $CE_2$  goes LOW simultaneously with  $\overline{WE}$  going HIGH, the output remains in a high-impedance state.
- 21. During this period the I/Os are in the output state and input signals should not be applied.

Switching Waveforms (continued)

Figure 9. Write Cycle No. 3 ( $\overline{WE}$  Controlled,  $\overline{OE}$  LOW) [22, 23]



Notes

22. The minimum write cycle pulse width should be equal to the sum of  $t_{SD}$  and  $t_{HZWE}$ .

23. If  $\overline{CE}_1$  goes HIGH or  $\overline{CE}_2$  goes LOW simultaneously with  $\overline{WE}$  going HIGH, the output remains in a high-impedance state.

24. During this period the I/Os are in the output state and input signals should not be applied.

### Truth Table

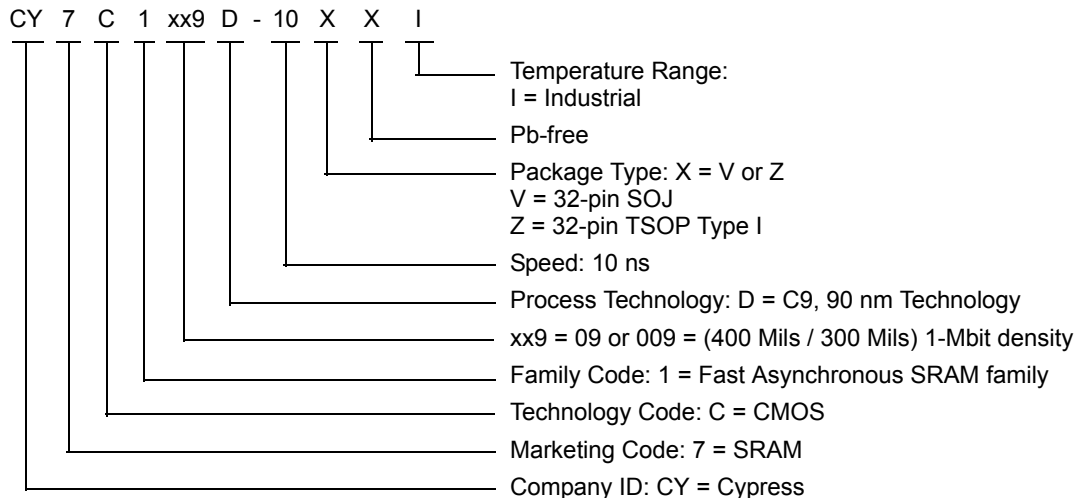
$\overline{CE}_1$	$CE_2$	$\overline{OE}$	$\overline{WE}$	I/O <sub>0</sub> –I/O <sub>7</sub>	Mode	Power
H	X	X	X	High Z	Power-down	Standby (I <sub>SB</sub> )
X	L	X	X	High Z	Power-down	Standby (I <sub>SB</sub> )
L	H	L	H	Data Out	Read	Active (I <sub>CC</sub> )
L	H	X	L	Data In	Write	Active (I <sub>CC</sub> )
L	H	H	H	High Z	Selected, Outputs Disabled	Active (I <sub>CC</sub> )

### Ordering Information

Speed (ns)	Ordering Code	Package Diagram	Package Type	Operating Range
10	CY7C109D-10VXI	51-85033	32-pin SOJ (400 Mils) Pb-free	Industrial
	CY7C109D-10ZXI	51-85056	32-pin TSOP (Type I) Pb-free	
	CY7C1009D-10VXI	51-85041	32-pin SOJ (300 Mils) Pb-free	

Please contact your local Cypress sales representative for availability of these parts.

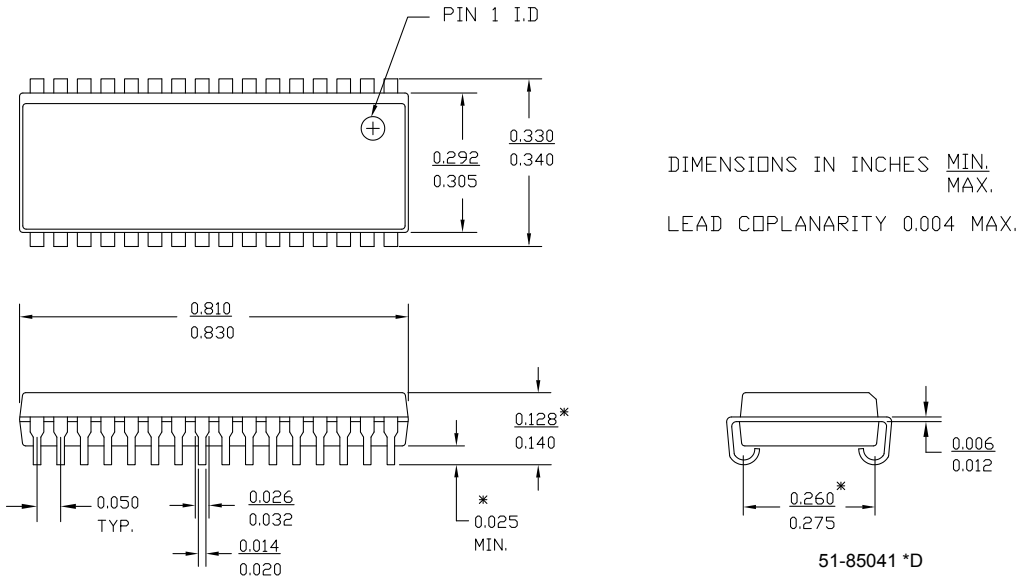
### Ordering Code Definitions



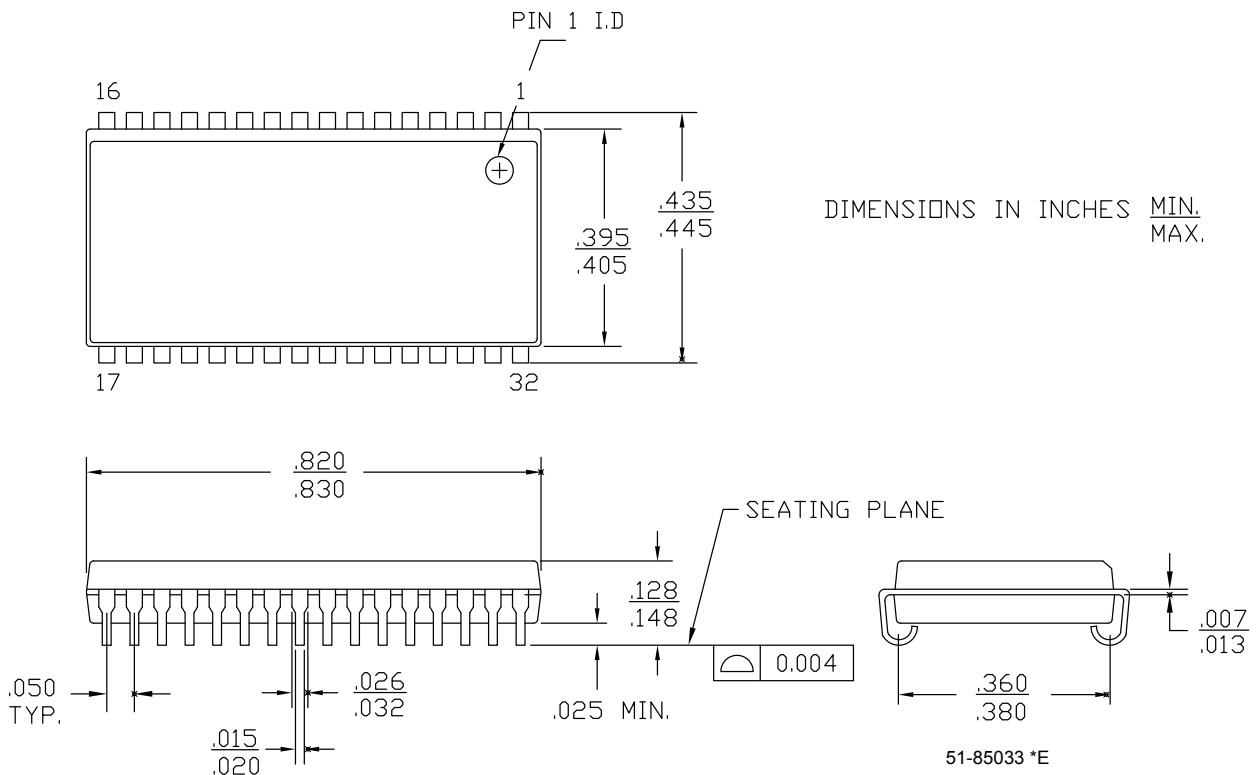
**Package Diagrams**

**Figure 10. 32-pin SOJ (300 Mils) V32.3 (Catalog 32.3 Molded SOJ) Package Outline, 51-85041**

32 Lead (300 MIL) Molded SOJ

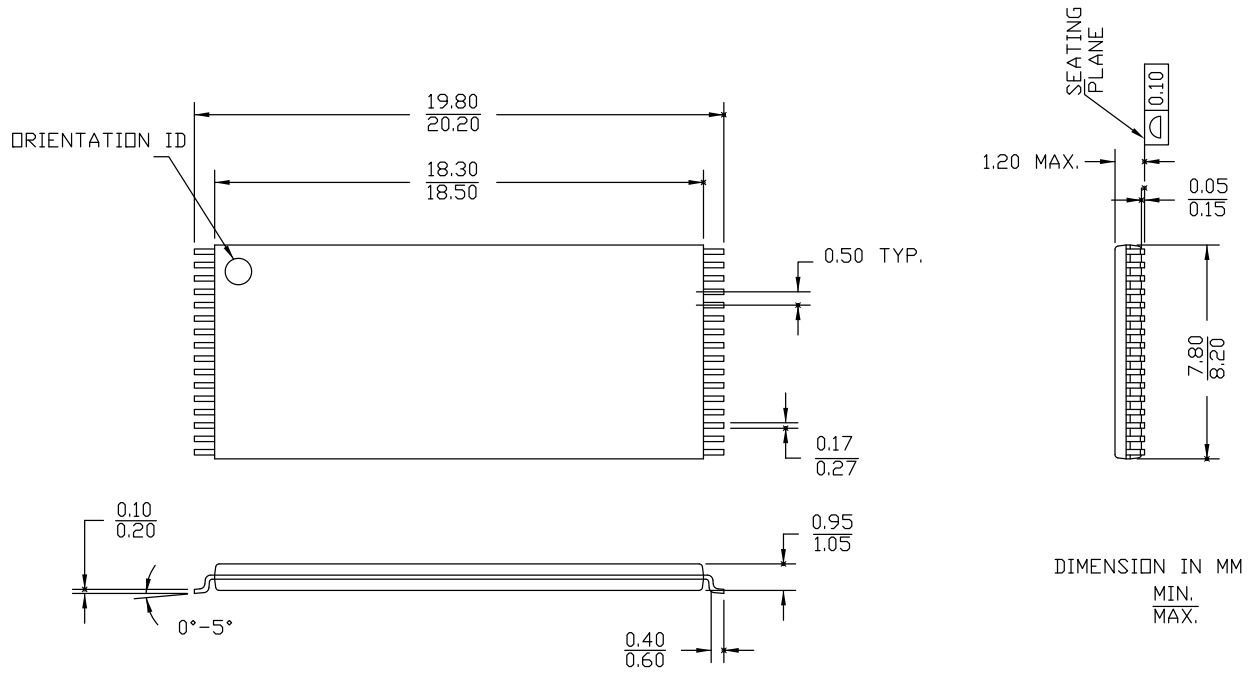


**Figure 11. 32-pin SOJ (400 Mils) V32.4 (Molded SOJ V33) Package Outline, 51-85033**



Package Diagrams (continued)

Figure 12. 32-pin TSOP I (8 × 20 × 1.0 mm) Z32R Package Outline, 51-85056



51-85056 \*G

## Acronyms

Acronym	Description
$\overline{CE}$	Chip Enable
CMOS	Complementary Metal Oxide Semiconductor
I/O	Input/Output
$\overline{OE}$	Output Enable
SRAM	Static random access memory
SOJ	Small Outline J-Lead
TSOP	Thin Small Outline Package
VFBGA	Very Fine-Pitch Ball Grid Array

## Document Conventions

### Units of Measure

Symbol	Unit of Measure
$^{\circ}\text{C}$	degree Celsius
MHz	megahertz
$\mu\text{A}$	microampere
mA	milliampere
mV	millivolt
mW	milliwatt
ns	nanosecond
pF	picofarad
V	volt
W	watt

## Document History Page

Document Title: CY7C109D/CY7C1009D, 1-Mbit (128 K × 8) Static RAM				
Document Number: 38-05468				
Revision	ECN	Submission Date	Orig. of Change	Description of Change
**	201560	See ECN	SWI	Advance Information data sheet for C9 IPP
*A	233722	See ECN	RKF	DC parameters are modified as per EROS (Spec # 01-2165) Pb-free offering in Ordering Information
*B	262950	See ECN	RKF	Added Data Retention Characteristics table Added T <sub>power</sub> Spec in Switching Characteristics Table Shaded Ordering Information
*C	See ECN	See ECN	RKF	Reduced Speed bins to -10 and -12 ns
*D	560995	See ECN	VKN	Converted from Preliminary to Final Removed Commercial Operating range Removed 12 ns speed bin Added I <sub>CC</sub> values for the frequencies 83MHz, 66MHz and 40MHz Changed Overshoot spec from V <sub>CC</sub> +2 V to V <sub>CC</sub> +1 V in footnote #3 Updated Thermal Resistance table Updated Ordering Information Table
*E	802877	See ECN	VKN	Changed I <sub>CC</sub> spec from 60 mA to 80 mA for 100 MHz, 55 mA to 72 mA for 83 MHz, 45 mA to 58 mA for 66 MHz, 30 mA to 37 mA for 40 MHz
*F	3104943	12/08/2010	AJU	Added <a href="#">Ordering Code Definitions</a> . Updated <a href="#">Package Diagrams</a> .
*G	3220123	04/08/2011	PRAS	Updated package diagrams: 51-85033 to *D 51-85056 to *F Added Acronyms and Units of measure. Updated template and styles as per current Cypress standards.
*H	4041855	06/27/2013	MEMJ	Updated <a href="#">Functional Description</a> . Updated <a href="#">Electrical Characteristics</a> : Added one more Test Condition "I <sub>OH</sub> = -0.1 mA" for V <sub>OH</sub> parameter and added maximum value corresponding to that Test Condition. Added Note 4 and referred the same note in maximum value for V <sub>OH</sub> parameter corresponding to Test Condition "I <sub>OH</sub> = -0.1 mA". Updated <a href="#">Package Diagrams</a> : spec 51-85041 – Changed revision from *B to *C. Updated in new template.
*I	4386284	05/21/2014	MEMJ	Updated <a href="#">Package Diagrams</a> : spec 51-85033 – Changed revision from *D to *E. spec 51-85056 – Changed revision from *F to *G. Completing Sunset Review.
*J	4578447	01/16/2015	MEMJ	Added related documentation hyperlink in page 1. Updated <a href="#">Figure 10</a> in <a href="#">Package Diagrams</a> (spec 51-85041 *C to *D).

## Sales, Solutions, and Legal Information

### Worldwide Sales and Design Support

Cypress maintains a worldwide network of offices, solution centers, manufacturer's representatives, and distributors. To find the office closest to you, visit us at [Cypress Locations](#).

#### Products

Automotive	<a href="http://cypress.com/go/automotive">cypress.com/go/automotive</a>
Clocks & Buffers	<a href="http://cypress.com/go/clocks">cypress.com/go/clocks</a>
Interface	<a href="http://cypress.com/go/interface">cypress.com/go/interface</a>
Lighting & Power Control	<a href="http://cypress.com/go/powerpsoc">cypress.com/go/powerpsoc</a>
Memory	<a href="http://cypress.com/go/memory">cypress.com/go/memory</a>
PSoC	<a href="http://cypress.com/go/psoc">cypress.com/go/psoc</a>
Touch Sensing	<a href="http://cypress.com/go/touch">cypress.com/go/touch</a>
USB Controllers	<a href="http://cypress.com/go/USB">cypress.com/go/USB</a>
Wireless/RF	<a href="http://cypress.com/go/wireless">cypress.com/go/wireless</a>

#### PSoC<sup>®</sup> Solutions

[psoc.cypress.com/solutions](http://psoc.cypress.com/solutions)  
PSoC 1 | PSoC 3 | PSoC 4 | PSoC 5LP

#### Cypress Developer Community

[Community](#) | [Forums](#) | [Blogs](#) | [Video](#) | [Training](#)

#### Technical Support

[cypress.com/go/support](http://cypress.com/go/support)

---

© Cypress Semiconductor Corporation, 2004-2015. The information contained herein is subject to change without notice. Cypress Semiconductor Corporation assumes no responsibility for the use of any circuitry other than circuitry embodied in a Cypress product. Nor does it convey or imply any license under patent or other rights. Cypress products are not warranted nor intended to be used for medical, life support, life saving, critical control or safety applications, unless pursuant to an express written agreement with Cypress. Furthermore, Cypress does not authorize its products for use as critical components in life-support systems where a malfunction or failure may reasonably be expected to result in significant injury to the user. The inclusion of Cypress products in life-support systems application implies that the manufacturer assumes all risk of such use and in doing so indemnifies Cypress against all charges.

Any Source Code (software and/or firmware) is owned by Cypress Semiconductor Corporation (Cypress) and is protected by and subject to worldwide patent protection (United States and foreign), United States copyright laws and international treaty provisions. Cypress hereby grants to licensee a personal, non-exclusive, non-transferable license to copy, use, modify, create derivative works of, and compile the Cypress Source Code and derivative works for the sole purpose of creating custom software and or firmware in support of licensee product to be used only in conjunction with a Cypress integrated circuit as specified in the applicable agreement. Any reproduction, modification, translation, compilation, or representation of this Source Code except as specified above is prohibited without the express written permission of Cypress.

Disclaimer: CYPRESS MAKES NO WARRANTY OF ANY KIND, EXPRESS OR IMPLIED, WITH REGARD TO THIS MATERIAL, INCLUDING, BUT NOT LIMITED TO, THE IMPLIED WARRANTIES OF MERCHANTABILITY AND FITNESS FOR A PARTICULAR PURPOSE. Cypress reserves the right to make changes without further notice to the materials described herein. Cypress does not assume any liability arising out of the application or use of any product or circuit described herein. Cypress does not authorize its products for use as critical components in life-support systems where a malfunction or failure may reasonably be expected to result in significant injury to the user. The inclusion of Cypress' product in a life-support systems application implies that the manufacturer assumes all risk of such use and in doing so indemnifies Cypress against all charges.

Use may be limited by and subject to the applicable Cypress software license agreement.

## Looking for pricing, stock, or lifecycle information?

Click below to explore more details on WIN SOURCE:

 [View CY7C109D-10VXI on WIN SOURCE](#)

 [Infineon Technologies](#) Information

## Optimize Your Supply Chain with WIN SOURCE Solutions

-  Global Sourcing Solution
-  Obsolete Management
-  Cost Control Management
-  Shortage Management
-  Alternative Solution
-  Excess Inventory Management