

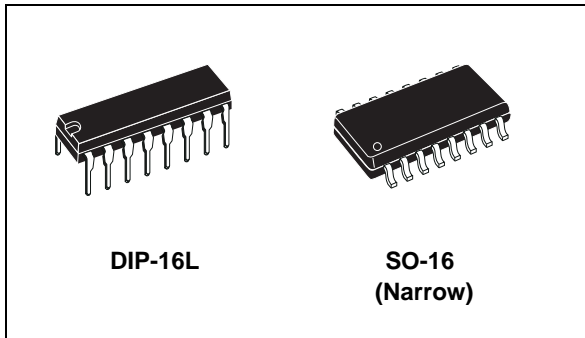

# THE DATASHEET OF ULN2002A





### Features

- Seven Darlington pairs per package
- Output current 500 mA per driver (600 mA peak)
- Output voltage 50 V
- Integrated suppression diodes for inductive loads
- Outputs can be paralleled for higher current
- TTL/CMOS/PMOS/DTL compatible inputs
- Input pins placed opposite to output pins to simplify layout

### Description

The ULN2001, ULN2002, ULN2003 and ULN2004 are high-voltage, high-current Darlington arrays each containing seven open collector Darlington pairs with common emitters. Each channel is rated at 500 mA and can withstand peak currents of 600 mA. Suppression diodes are included for inductive load driving and the inputs are pinned opposite the outputs to simplify board layout.

The versions interface to all common logic families: ULN2001 (general purpose, DTL, TTL, PMOS, CMOS); ULN2002 (14 - 25 V PMOS); ULN2003 (5 V TTL, CMOS); ULN2004 (6 - 15 V CMOS, PMOS).

These versatile devices are useful for driving a wide range of loads including solenoids, relay DC motors, LED display filament lamps, thermal printheads and high-power buffers.

The ULN2001A/2002A/2003A and 2004A are supplied in a 16-pin DIP package with a copper leadframe to reduce thermal resistance. They are available also in small outline package (SO-16) as ULN2001D1/2002D1/2003D1/ 2004D1.

# Contents

<b>1</b>	<b>Diagram</b> .....	<b>3</b>
<b>2</b>	<b>Pin configuration</b> .....	<b>4</b>
<b>3</b>	<b>Maximum ratings</b> .....	<b>5</b>
<b>4</b>	<b>Electrical characteristics</b> .....	<b>6</b>
<b>5</b>	<b>Test circuits</b> .....	<b>7</b>
<b>6</b>	<b>Typical performance characteristics</b> .....	<b>9</b>
<b>7</b>	<b>Package information</b> .....	<b>11</b>
	7.1 DIP-16L package information .....	11
	7.2 SO-16 Narrow package information .....	13
<b>8</b>	<b>Order codes</b> .....	<b>15</b>
<b>9</b>	<b>Revision history</b> .....	<b>16</b>

# 1 Diagram

Figure 1. Schematic diagram

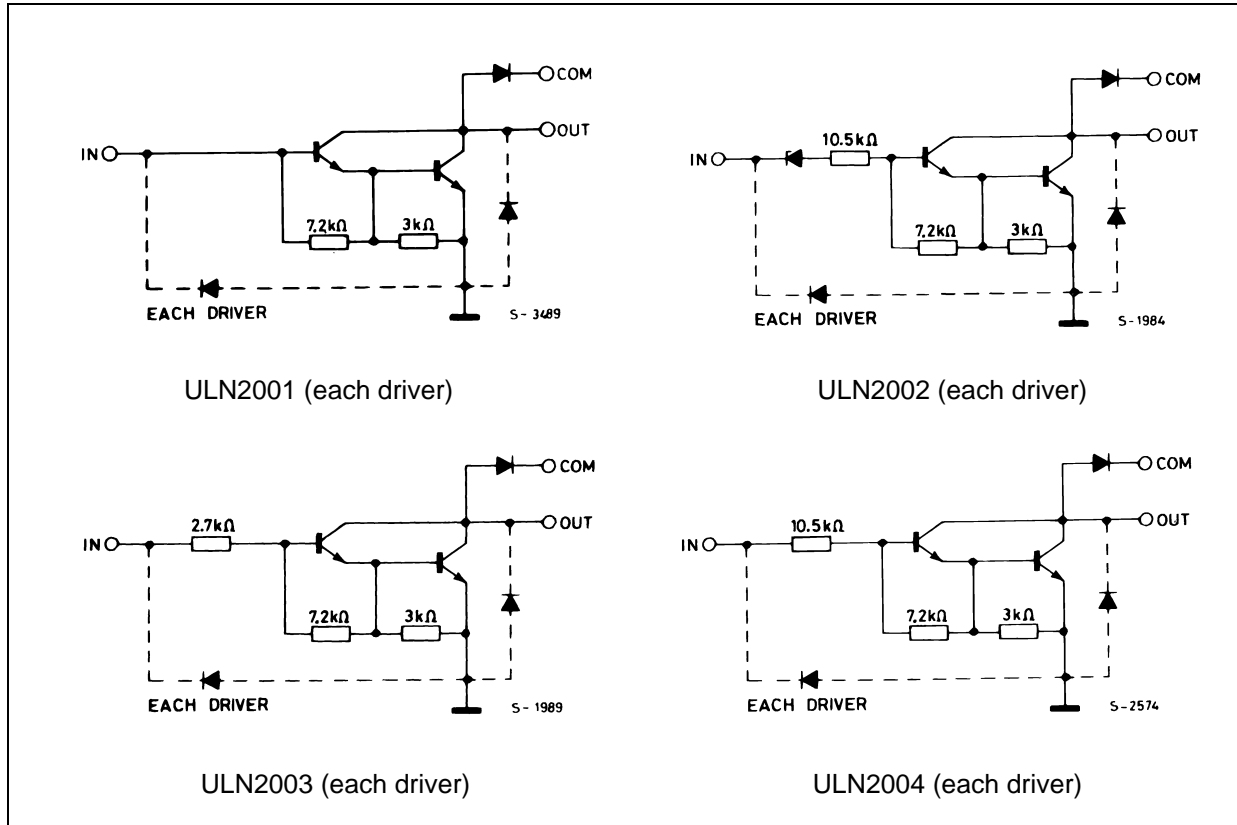

## 2 Pin configuration

Figure 2. Pin connections (top view)

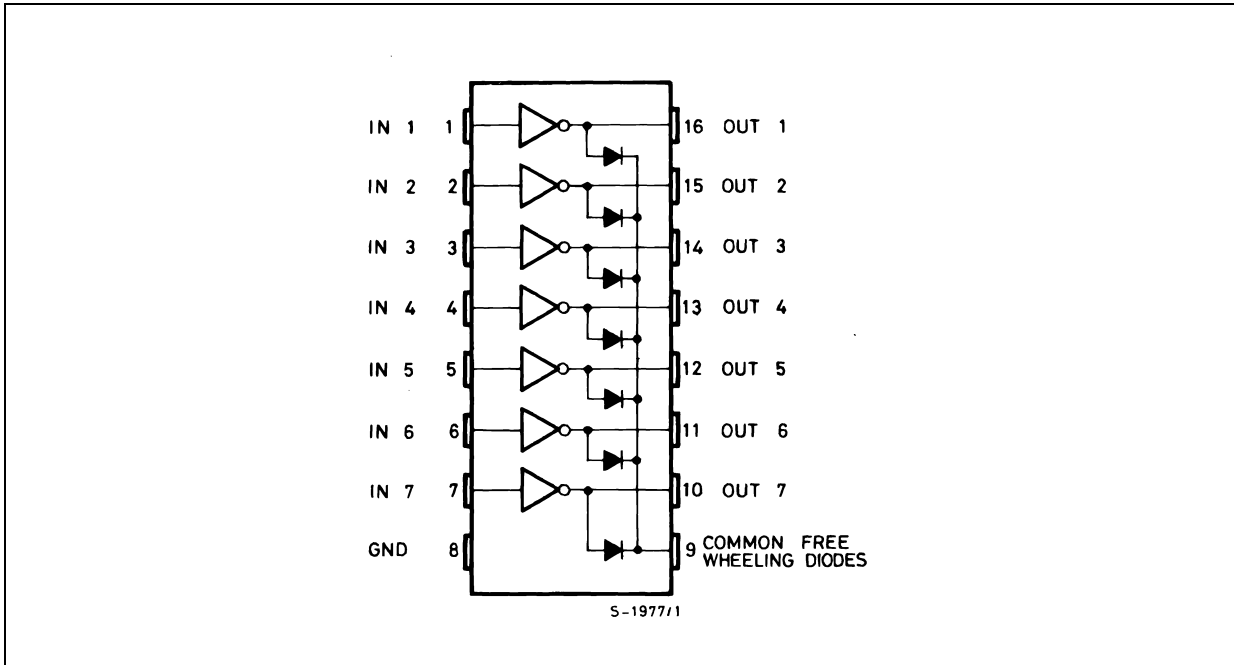

### 3 Maximum ratings

**Table 1. Absolute maximum ratings**

Symbol	Parameter	Value	Unit
$V_O$	Output voltage	50	V
$V_I$	Input voltage (for ULN2002A/D - 2003A/D - 2004A/D)	30	V
$I_C$	Continuous collector current	500	mA
$I_B$	Continuous base current	25	mA
$I_F$	Clamping diode continuous current	350	mA
$V_R$	Clamping diode reverse voltage	50	V
$T_A$	Operating ambient temperature range	- 40 to 85	°C
$T_{STG}$	Storage temperature range	- 55 to 150	°C
$T_J$	Junction temperature	150	°C
ESD	Electrostatic discharge rating - HBM	2	kV

**Table 2. Thermal data**

Symbol	Parameter	DIP-16	SO-16	Unit
$R_{thJA}$	Thermal resistance junction-ambient, Max.	70	120	°C/W

*Note:* Maximum power dissipation is a function of  $T_{J(max)}$ ,  $R_{thJA}$  and  $T_A$ . The maximum allowable power dissipation at any allowable ambient temperature is  $P_D = (T_{J(max)} - T_A) / R_{thJA}$ . Operating at the absolute maximum  $T_J$  of +150°C can affect reliability.

## 4 Electrical characteristics

$T_A = 25\text{ °C}$  unless otherwise specified.

**Table 3. Electrical characteristics**

Symbol	Parameter	Test condition	Min.	Typ.	Max.	Unit
$I_{CEX}$	Output leakage current	$V_{CE} = 50\text{ V}$ , (Figure 3)			50	$\mu\text{A}$
		$T_A = 85\text{ °C}$ , $V_{CE} = 50\text{ V}$ (Figure 3)			100	
		$T_A = 85\text{ °C}$ for ULN2002, $V_{CE} = 50\text{ V}$ , $V_I = 6\text{ V}$ (Figure 4)			500	
		$T_A = 85\text{ °C}$ for ULN2002, $V_{CE} = 50\text{ V}$ , $V_I = 1\text{ V}$ (Figure 4)			500	
$V_{CE(SAT)}$	Collector-emitter saturation voltage (Figure 5)	$I_C = 100\text{ mA}$ , $I_B = 250\text{ }\mu\text{A}$		0.9	1.1	V
		$I_C = 200\text{ mA}$ , $I_B = 350\text{ }\mu\text{A}$		1.1	1.3	
		$I_C = 350\text{ mA}$ , $I_B = 500\text{ }\mu\text{A}$		1.3	1.6	
$I_{I(ON)}$	Input current (Figure 6)	for ULN2002, $V_I = 17\text{ V}$		0.82	1.25	mA
		for ULN2003, $V_I = 3.85\text{ V}$		0.93	1.35	
		for ULN2004, $V_I = 5\text{ V}$		0.35	0.5	
		$V_I = 12\text{ V}$		1	1.45	
$I_{I(OFF)}$	Input current (Figure 7)	$T_A = 85\text{ °C}$ , $I_C = 500\text{ }\mu\text{A}$	50	65		$\mu\text{A}$
$V_{I(ON)}$	Input voltage (Figure 8)	$V_{CE} = 2\text{ V}$ , for ULN2002			13	V
		$I_C = 300\text{ mA}$			2.4	
		for ULN2003			2.7	
		$I_C = 200\text{ mA}$			3	
		$I_C = 250\text{ mA}$			5	
		for ULN2004			6	
		$I_C = 125\text{ mA}$			7	
		$I_C = 200\text{ mA}$			8	
$h_{FE}$	DC Forward current gain (Figure 5)	for ULN2001, $V_{CE} = 2\text{ V}$ , $I_C = 350\text{ mA}$	1000			
$C_I$	Input capacitance			15	25	pF
$t_{PLH}$	Turn-on delay time	$0.5 V_I$ to $0.5 V_O$		0.25	1	$\mu\text{s}$
$t_{PHL}$	Turn-off delay time	$0.5 V_I$ to $0.5 V_O$		0.25	1	$\mu\text{s}$
$I_R$	Clamp diode leakage current (Figure 9)	$V_R = 50\text{ V}$			50	$\mu\text{A}$
		$T_A = 85\text{ °C}$ , $V_R = 50\text{ V}$			100	
$V_F$	Clamp diode forward voltage (Figure 10)	$I_F = 350\text{ mA}$		1.7	2	V

# 5 Test circuits

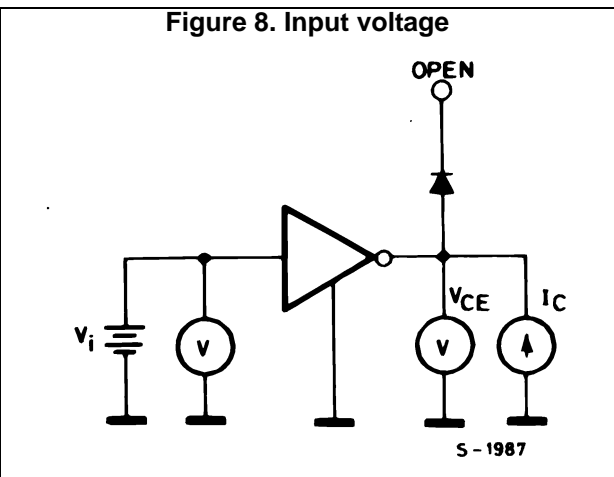
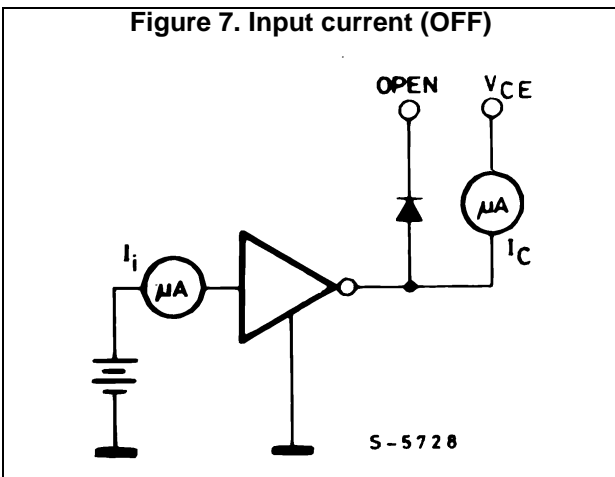
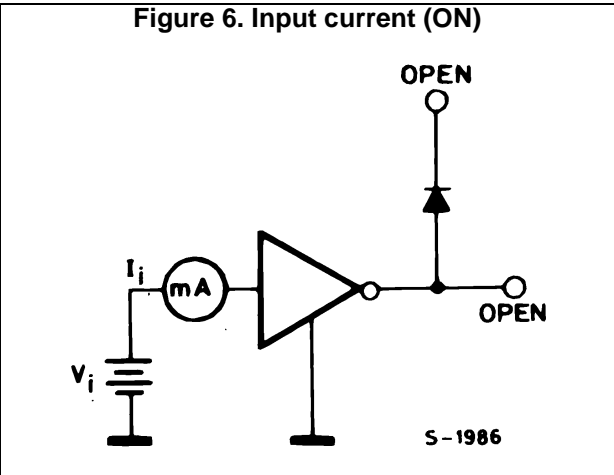
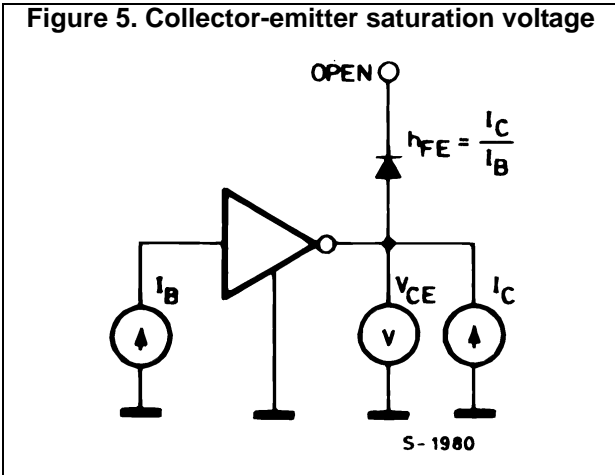
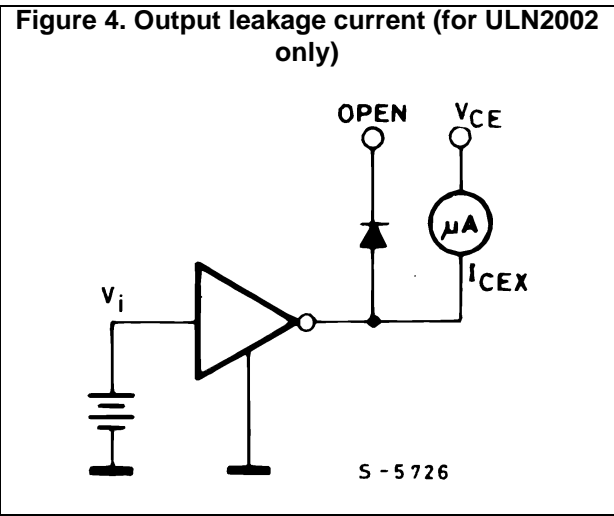
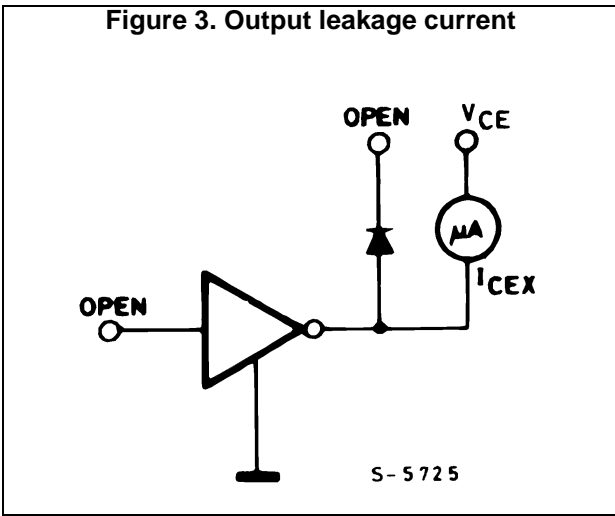

Figure 9. Clamp diode leakage current

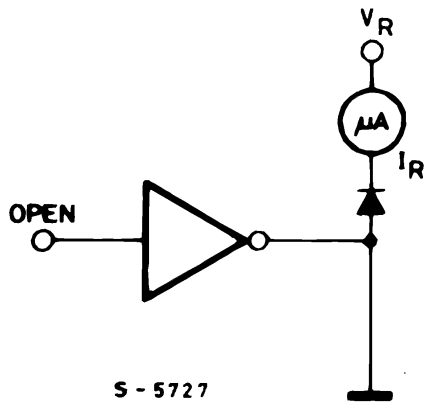
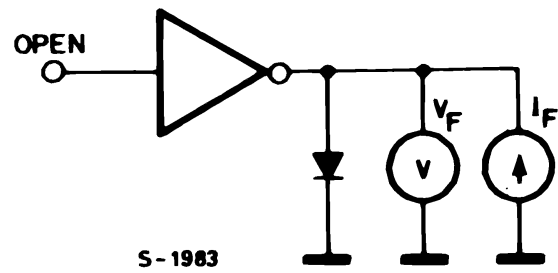

Figure 10. Clamp diode forward voltage



## 6 Typical performance characteristics

Figure 11. Collector current vs. saturation voltage ( $T_J = 25^\circ\text{C}$ )

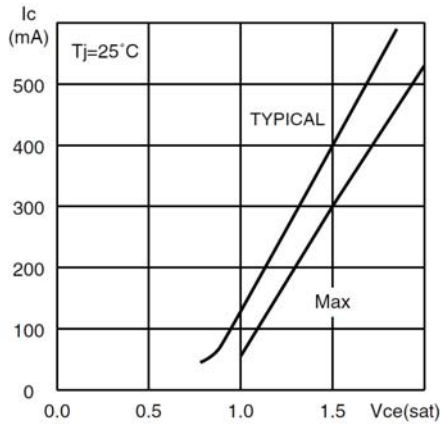

Figure 12. Collector current vs. saturation voltage

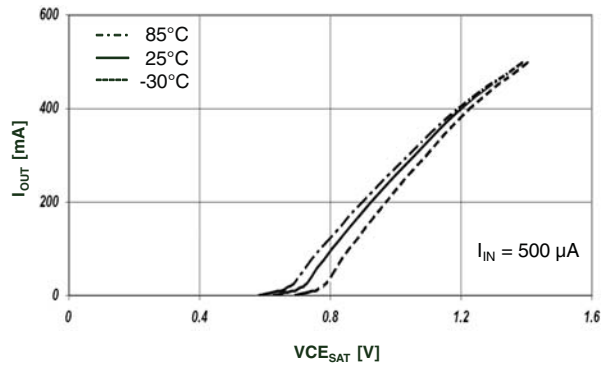

Figure 13. Input current vs. input voltage

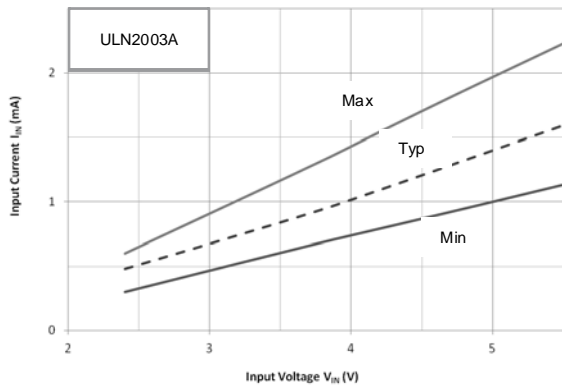

Figure 14. Input current vs. input voltage ( $T_a = 25^\circ\text{C}$ )

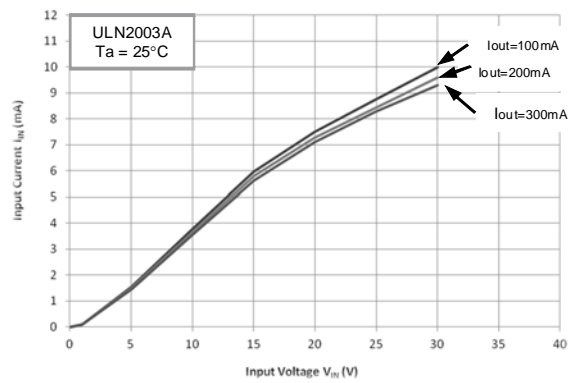

Figure 15. Collector current vs. input current

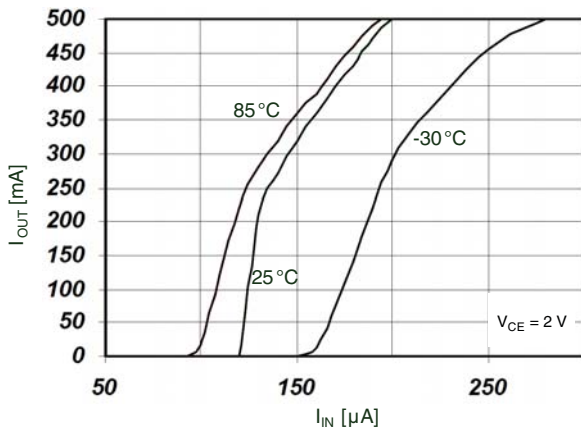
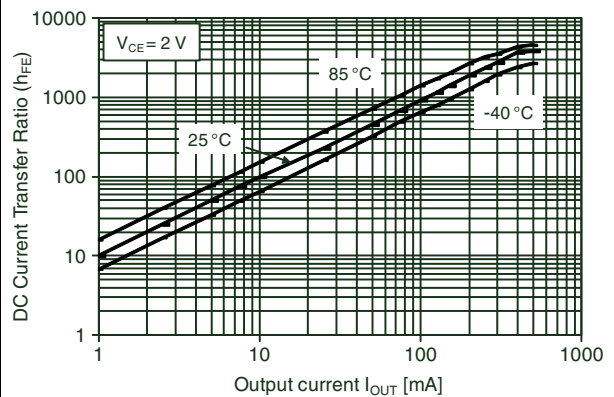
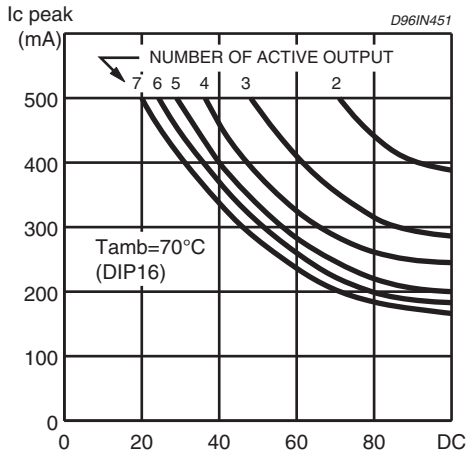

Figure 16.  $h_{FE}$  vs. output current



**Figure 17. Peak collector current vs. duty cycle (DIP-16)**



**Figure 18. Peak collector current vs. duty cycle (SO-16)**

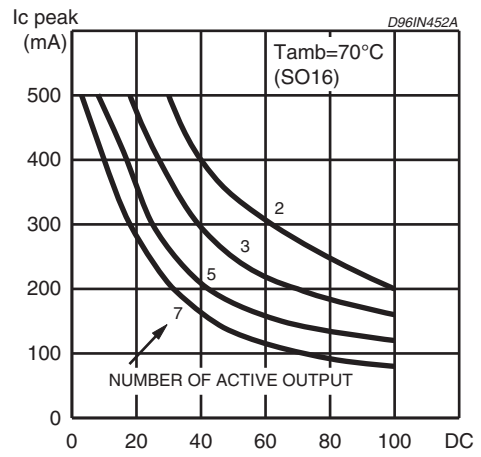

## 7 Package information

In order to meet environmental requirements, ST offers these devices in different grades of ECOPACK packages, depending on their level of environmental compliance. ECOPACK specifications, grade definitions and product status are available at: [www.st.com](http://www.st.com). ECOPACK is an ST trademark.

### 7.1 DIP-16L package information

Figure 19. DIP-16L package outline

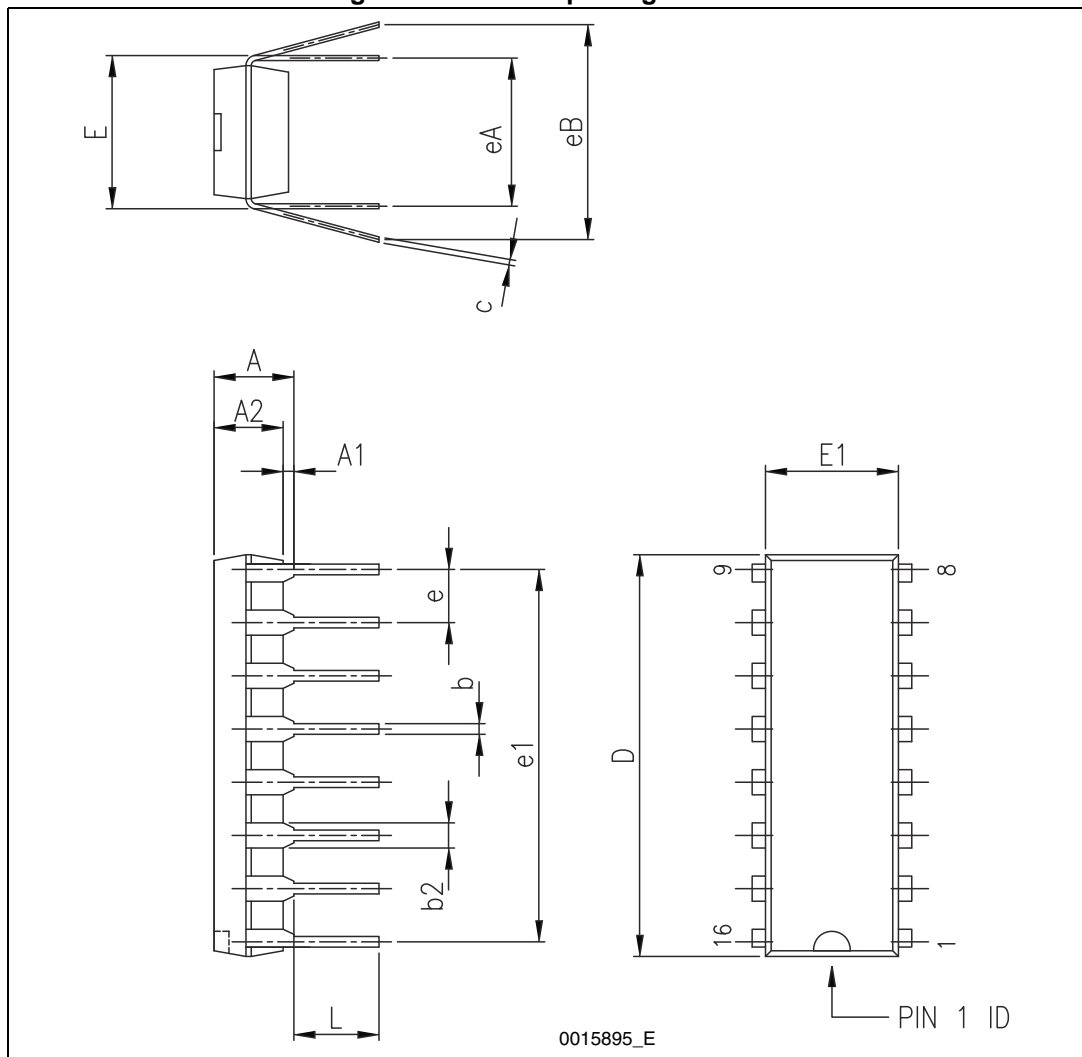

Table 4. DIP-16L mechanical data

Dim.	mm.		
	Min.	Typ.	Max.
A			5.33
A1	0.38		
A2	2.92	3.30	4.95
b	0.36	0.46	0.56
b2	1.14	1.52	1.78
c	0.20	0.25	0.36
D	18067	19.18	19.69
E	7.62	7.87	8.26
E1	6.10	6.35	7.11
e		2.54	
e1		17.78	
eA		7.62	
eB			10.92
L	2.92	3.30	3.81

## 7.2 SO-16 Narrow package information

Figure 20. SO-16 package outline

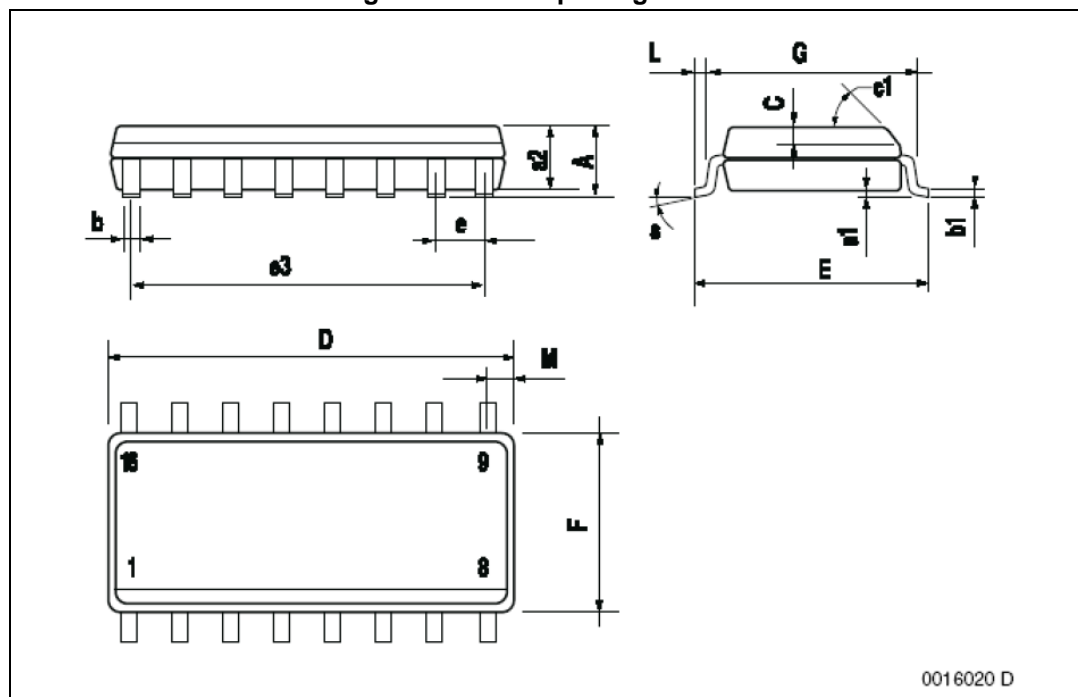

Table 5. SO-16 Narrow mechanical data

Dim.	mm.			inch.		
	Min.	Typ.	Max.	Min.	Typ.	Max.
A			1.75			0.069
a1	0.1		0.25	0.004		0.009
a2			1.6			0.063
b	0.35		0.46	0.014		0.018
b1	0.19		0.25	0.007		0.010
C		0.5			0.020	
c1			45°	(typ.)		
D(1)	9.8		10	0.386		0.394
E	5.8		6.2	0.228		0.244
e		1.27			0.050	
e3		8.89			0.350	
F(1)	3.8		4.0	0.150		0.157
G	4.60		5.30	0.181		0.208
L	0.4		1.27	0.150		0.050
M			0.62			0.024
S	8° (max.)					

## 8 Order codes

**Table 6. Order codes**

<b>Part number</b>	<b>Package</b>
ULN2001A	DIP-16
ULN2002A	DIP-16
ULN2003A	DIP-16
ULN2004A	DIP-16
ULN2001D1013TR	SO-16 in tape and reel
ULN2002D1013TR	SO-16 in tape and reel
ULN2003D1013TR	SO-16 in tape and reel
ULN2004D1013TR	SO-16 in tape and reel

## 9 Revision history

**Table 7. Revision history**

Date	Revision	Changes
05-Dec-2006	5	Order code updated and document reformatted.
28-Aug-2007	6	Added Table 1 in cover page.
07-May-2012	7	Modified: Figure 12 on page 9. Added: Figure 13, 14, 15 and Figure 16 on page 9.
01-Jun-2012	8	Updated: DIP-16L package mechanical data Table 4 on page 12 and Figure 19 on page 11.
22-Jul-2015	9	Added Plastic DIP16-L package. Removed Device summary table. Updated Table 7: Order code. Added Section 7.2: Plastic DIP-16L package information. Minor text changes.
07-Nov-2017	10	Removed plastic DIP-16L package and associated order code ULN2003A
27-Jun-2018	11	Updated: $I_{I(ON)}$ test condition in Table 3: Electrical characteristics.
09-Jul-2019	12	Added $I_F$ , $V_R$ , ESD parameters in <a href="#">Table 1: Absolute maximum ratings</a> and note in <a href="#">Table 2: Thermal data</a> .

**IMPORTANT NOTICE – PLEASE READ CAREFULLY**

STMicroelectronics NV and its subsidiaries (“ST”) reserve the right to make changes, corrections, enhancements, modifications, and improvements to ST products and/or to this document at any time without notice. Purchasers should obtain the latest relevant information on ST products before placing orders. ST products are sold pursuant to ST’s terms and conditions of sale in place at the time of order acknowledgement.

Purchasers are solely responsible for the choice, selection, and use of ST products and ST assumes no liability for application assistance or the design of Purchasers’ products.

No license, express or implied, to any intellectual property right is granted by ST herein.

Resale of ST products with provisions different from the information set forth herein shall void any warranty granted by ST for such product.



ST and the ST logo are trademarks of ST. For additional information about ST trademarks, please refer to [www.st.com/trademarks](http://www.st.com/trademarks). All other product or service names are the property of their respective owners.

Information in this document supersedes and replaces information previously supplied in any prior versions of this document.

© 2019 STMicroelectronics – All rights reserved

## Looking for pricing, stock, or lifecycle information?

Click below to explore more details on WIN SOURCE:

-  [View ULN2002A](#) on WIN SOURCE
-  [STMicroelectronics](#) Information

## Optimize Your Supply Chain with WIN SOURCE Solutions

-  Global Sourcing Solution
-  Obsolete Management
-  Cost Control Management
-  Shortage Management
-  Alternative Solution
-  Excess Inventory Management