



**THE DATASHEET OF
SCAN921821TSM/NOPB**



SCAN921821 Dual 18-Bit Serializer with Pre-emphasis, IEEE 1149.1 (JTAG), and At-Speed BIST

Check for Samples: [SCAN921821](#)

FEATURES

- **15-66 MHz Dual 18:1 Serializer with 2.376 Gbps Total Throughput**
- **8-level Selectable Pre-emphasis on Each Channel Drives Lossy Cables and Backplanes**
- **>15kV HBM ESD Protection on Bus LVDS I/O Pins**
- **Robust BLVDS Serial Data Transmission with Embedded Clock for Exceptional Noise Immunity and Low EMI**
- **Power Saving Control Pin for Each Channel**
- **IEEE 1149.1 "JTAG" Compliant**
- **At-Speed BIST - PRBS Generation**
- **No External Coding Required**
- **Internal PLL, No External PLL Components Required**
- **Single +3.3V Power Supply**
- **Low Power: 260 mW (typ) Per Channel at 66 MHz with PRBS-15 Pattern**
- **Single 3.3 V Supply**
- **Fabricated with Advanced CMOS Process Technology**
- **Industrial –40 to +85°C Temperature Range**
- **Compact 100-ball NFBGA Package**

DESCRIPTION

The SCAN921821 is a dual channel 18-bit serializer featuring signal conditioning, boundary SCAN, and at-speed BIST. Each serializer block transforms an 18-bit parallel LVCMOS/LVTTL data bus into a single Bus LVDS data stream with embedded clock. This single serial data stream with embedded clock simplifies PCB design and reduces PCB cost by narrowing data paths that in turn reduce PCB size and layers. The single serial data stream also reduces cable size, the number of connectors, and eliminates clock-to-data and data-to-data skew.

Each channel also has an 8-level selectable pre-emphasis feature that significantly extends performance over lossy interconnect. Each channel also has its own powerdown pin that saves power by reducing supply current when the channel is not being used.

The SCAN921821 also incorporates advanced testability features including IEEE 1149.1 and at-speed BIST PRBS pattern generation to facilitate verification of board and link integrity



Please be aware that an important notice concerning availability, standard warranty, and use in critical applications of Texas Instruments semiconductor products and disclaimers thereto appears at the end of this data sheet.

All trademarks are the property of their respective owners.

Block Diagram

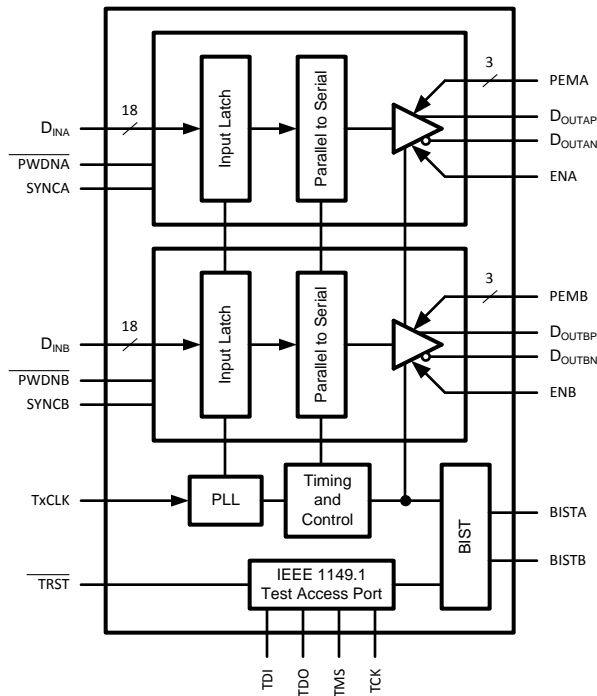

These devices have limited built-in ESD protection. The leads should be shorted together or the device placed in conductive foam during storage or handling to prevent electrostatic damage to the MOS gates.

Absolute Maximum Ratings (1)(2)

Supply Voltage (V _{DD})		-0.3V to +4V	
Supply Voltage (V _{DD}) Ramp Rate		< 30 V/ms	
LVC MOS/LVTTL Input Voltage		-0.3V to (V _{DD} +0.3V)	
LVC MOS/LVTTL Output Voltage		-0.3V to (V _{DD} +0.3V)	
Bus LVDS Driver Output Voltage		-0.3V to +3.9V	
Bus LVDS Output Short Circuit Duration		10ms	
Junction Temperature		+150°C	
Storage Temperature		-65°C to +150°C	
Lead Temperature (Soldering, 4 seconds)		+220°C	
Maximum Package Power Dissipation at 25°C	NFBGA-100	3.57 W	
	Derating Above 25°C	28.57 mW/°C	
Thermal resistance	θ _{JA}	35°C/W	
	θ _{JC}	11.1°C/W	
ESD Rating	HBM, 1.5 KΩ, 100 pF	All pins	>8 kV
		Bus LVDS pins	>15 kV
	MM, 0Ω, 200 pF		>1200 V
	CDM		>2 kV

- (1) "Absolute Maximum Ratings" are those values beyond which the safety of the device cannot be specified. They are not meant to imply that the devices should be operated at these limits. The table of "Electrical Characteristics" specifies conditions of device operation.
- (2) If Military/Aerospace specified devices are required, please contact the TI Sales Office/ Distributors for availability and specifications.

Recommended Operating Conditions

	Min	Nom	Max	Units
Supply Voltage (V_{DD})	3.15	3.3	3.45	V
Operating Free Air Temperature (T_A)	-40	+25	+85	°C
Clock Rate	15		66	MHz
Supply Noise			100	mV p-p

DC Electrical Characteristics

Over recommended operating supply and temperature ranges unless otherwise specified. ⁽¹⁾⁽²⁾

Symbol	Parameter	Conditions	Min	Typ	Max	Units
LVCMOS/LVTTL Input DC Specifications						
V_{IH}	High Level Input Voltage		2.0		V_{DD}	V
V_{IL}	Low Level Input Voltage		GND		0.8	V
V_{CL}	Input Clamp Voltage	$I_{CL} = -18$ mA	-1.5	-0.7		V
I_{INH}	High Level Input Current	$V_{IN} = V_{DD} = V_{DDMAX}$	-20	±2	+20	µA
I_{INL}	Low Level Output Current	$V_{IN} = V_{SS}, V_{DD} = V_{DDMAX}$	-10	±2	+10	µA
1149.1 (JTAG) DC Specifications						
V_{IH}	High Level Input Voltage		2.0		V_{DD}	V
V_{IL}	Low Level Input Voltage		GND		0.8	V
V_{CL}	Input Clamp Voltage	$I_{CL} = -18$ mA	-1.5	-0.7		V
I_{INH}	High Level Input Current	$V_{IN} = V_{DD} = V_{DDMAX}$	-20		+20	µA
I_{INL}	Low Level Output Current	$V_{IN} = V_{SS}, V_{DD} = V_{DDMAX}$	-200		+200	µA
V_{OH}	High Level Output Voltage	$I_{OH} = -9$ mA	2.3		V_{DD}	mV
V_{OL}	Low Level Output Voltage	$I_{OL} = 9$ mA	GND		0.5	mV
I_{OS}	Output Short Circuit Current	$V_{OUT} = 0$ V	-100	-80	-50	mA
I_{OZ}	Output Tri-state Current	\overline{PWDN} or EN = 0.8V, $V_{OUT} = 0$ V	-10		+10	µA
		\overline{PWDN} or EN = 0.8V, $V_{OUT} = V_{DD}$	-30		+30	µA
Bus LVDS Output DC Specifications						
V_{OD}	Output Differential Voltage (DO+) - (DO-)	See Figure 10 , $R_L = 100\Omega$	450	500	550	mV
ΔV_{OD}	Output Differential Voltage Unbalance			2	15	mV
V_{OS}	Offset Voltage		1.05	1.2	1.25	V
ΔV_{OS}	Offset Voltage Unbalance			2.7	15	mV

(1) Typical values are given for $V_{CC} = 3.3$ V and $T_A = +25$ °C.

(2) Current into device pins is defined as positive. Current out of device pins is defined as negative. Voltages are referenced to ground except VOD, ΔV_{OD} , VTH and VTL which are differential voltages.

DC Electrical Characteristics (continued)

Over recommended operating supply and temperature ranges unless otherwise specified.⁽¹⁾⁽²⁾

Symbol	Parameter	Conditions	Min	Typ	Max	Units	
Q _{POV}	Pre-Emphasis Output Voltage Ratio V _{ODPRE} / V _{OD}	Pre-Emphasis Level = 1	1.10	1.24	1.35		
		Pre-Emphasis Level = 2	1.35	1.47	1.55		
		Pre-Emphasis Level = 3	1.55	1.70	1.80		
		Pre-Emphasis Level = 4	1.80	1.91	1.95		
		Pre-Emphasis Level = 5	1.95	2.08	2.20		
		Pre-Emphasis Level = 6	2.10	2.21	2.35		
		Pre-Emphasis Level = 7	2.15	2.30	2.50		
I _{OS}	Output Short Circuit Current	DO = 0V, Din = H, $\overline{\text{PWDN}}$ and EN = 2.4V	-10	-25	-75	mA	
I _{OZ}	TRI-STATE Output Current	$\overline{\text{PWDN}}$ or EN = 0.8V, DO = 0V ⁽³⁾	-10	± 1	+10	µA	
		$\overline{\text{PWDN}}$ or EN = 0.8V, DO = VDD ⁽³⁾	-55	± 6	+55	µA	
Power Supply Current (DVDD, PVDD and AVDD Pins)							
I _{DD}	Total Supply Current (includes load current)	C _L = 15pF, R _L = 100 Ω	f = 66 MHz, PRBS-15 Pattern		160	225	mA
			f = 66 MHz, Worst Case Pattern (Checker-Board Pattern)		180		mA
I _{DDP}	Total Supply Current with Pre-Emphasis (includes load current)	C _L = 15pF, R _L = 100 Ω	f = 66 MHz, PRBS-15 Pattern		240		mA
			f = 66 MHz, Worst Case Pattern (Checker-Board Pattern)		280	325	mA
I _{DDX}	Supply Current Powerdown	$\overline{\text{PWDN}}$ = 0.8V, EN = 0.8V		1.0	3.0	mA	

(3) I_{OZ} is measured at each pin. The DOUT pin not under test is floated to isolate the TRI-STATE current flow.

Timing Requirements for TCLK

Over recommended operating supply and temperature ranges unless otherwise specified.⁽¹⁾⁽²⁾

Symbol	Parameter	Conditions	Min	Typ	Max	Units
t _{TCP}	Transmit Clock Period		15.2	T	66.7	ns
t _{TCH}	Transmit Clock High Time		0.4T	0.5T	0.6T	ns
t _{TCL}	Transmit Clock Low Time		0.4T	0.5T	0.6T	ns
t _{CLKT}	TCLK Input Transition Time			3	6	ns
t _{JIT}	TCLK Input Jitter	See ⁽³⁾			80	ps (RMS)

(1) Typical values are given for V_{CC} = 3.3V and T_A = +25°C.

(2) Current into device pins is defined as positive. Current out of device pins is defined as negative. Voltages are referenced to ground except V_{OD}, ΔV_{OD}, V_{TH} and V_{TL} which are differential voltages.

(3) Specified by design using statistical analysis.

AC Electrical Characteristics

 Over recommended operating supply and temperature ranges unless otherwise specified. ⁽¹⁾ ⁽²⁾

Symbol	Parameter	Conditions	Min	Typ	Max	Units
Serializer AC Specifications						
t_{LLHT}	Bus LVDS Low-to-High Transition Time	See Figure 2 , ⁽³⁾ $R_L = 100\Omega$, $C_L = 10\text{pF}$ to GND		0.3	0.4	ns
t_{LHLT}	Bus LVDS High-to-Low Transition Time			0.3	0.4	ns
t_{DIS}	DIN (0-17) Setup to TCLK	See Figure 4 , ⁽³⁾ $R_L = 100\Omega$, $C_L = 10\text{pF}$ to GND	1.9			ns
t_{DIH}	DIN (0-17) Hold from TCLK		0.6			ns
t_{HZD}	DO \pm HIGH to TRI-STATE Delay	See Figure 5 $R_L = 100\Omega$, $C_L = 10\text{pF}$ to GND		3.9	10	ns
t_{LZD}	DO \pm LOW to TRI-STATE Delay			3.5	10	ns
t_{ZHD}	DO \pm TRI-STATE to HIGH Delay			3.2	10	ns
t_{ZLD}	DO \pm TRI-STATE to LOW Delay			2.4	10	ns
t_{SPW}	SYNC Pulse Width	See Figure 7 , $R_L = 100\Omega$	$5 \cdot t_{TCP}$		$6 \cdot t_{TCP}$	ns
t_{PLD}	Serializer PLL Lock Time	See Figure 6 , $R_L = 100\Omega$	$510 \cdot t_{TCP}$		$1024 \cdot t_{TCP}$	ns
t_{SD}	Serializer Delay	See Figure 8 , $R_L = 100\Omega$	$t_{TCP} + 2.5$	$t_{TCP} + 4.5$	$t_{TCP} + 6.5$	ns
t_{SKCC}	Channel to Channel Skew			70		ps
t_{RJIT}	Random Jitter	Room Temperature, $V_{DD} = 3.3\text{V}$, 66 MHz		6.1		ps (RMS)
t_{DJIT}	Deterministic Jitter Figure 9 , ⁽³⁾	15 MHz	-390		320	ps
		66 MHz	-60		30	ps
1149.1 (JTAG) AC Specifications						
f_{MAX}	Maximum TCK Clock Frequency	$C_L = 15\text{pF}$, $R_L = 500\Omega$	25			MHz
t_S	TDI or TMS Setup to TCK, H or L		2.4			ns
t_H	TDI or TMS Hold from TCK, H or L		2.8			ns
t_{W1}	TCK Pulse Width, H or L		10			ns
t_{W2}	$\overline{\text{TRST}}$ Pulse Width, L		10			ns
t_{REC}	Recovery Time, $\overline{\text{TRST}}$ to TCK		2			ns

 (1) Typical values are given for $V_{CC} = 3.3\text{V}$ and $T_A = +25^\circ\text{C}$.

 (2) Current into device pins is defined as positive. Current out of device pins is defined as negative. Voltages are referenced to ground except VOD, ΔVOD , VTH and VTL which are differential voltages.

(3) Specified by design using statistical analysis.

AC Timing Diagrams and Test Circuits

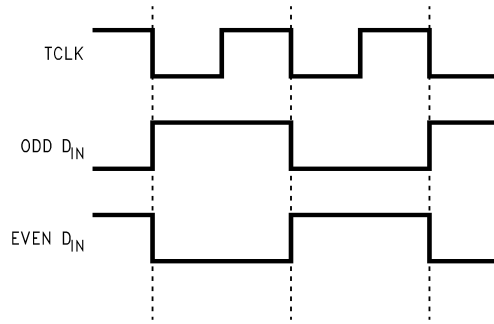

Figure 1. "Worst Case" Serializer IDD Test Pattern

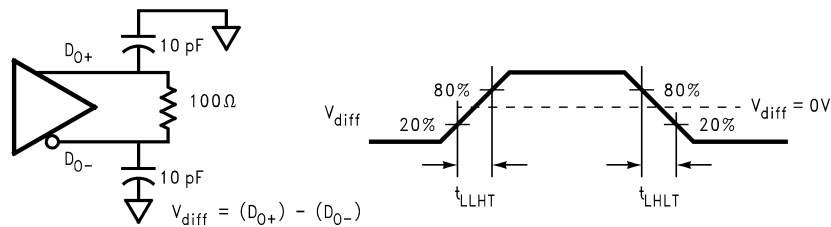

Figure 2. Serializer Bus LVDS Distributed Output Load and Transition Times

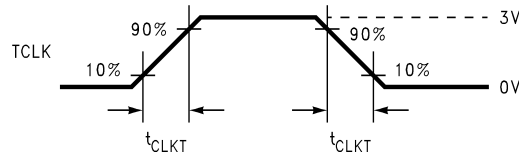

Figure 3. Serializer Input Clock Transition Time

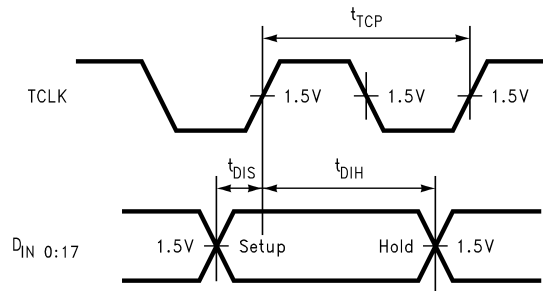

Figure 4. Serializer Setup/Hold Times

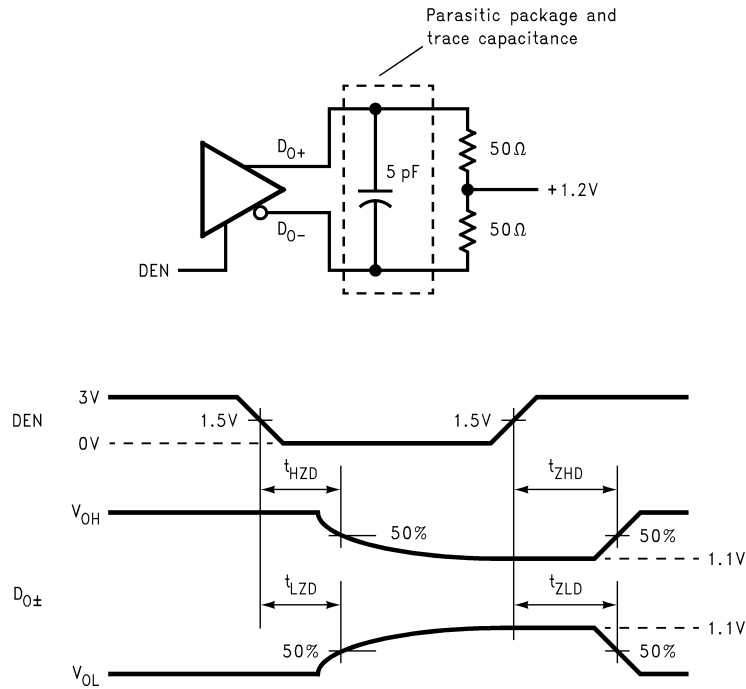

Figure 5. Serializer TRI-STATE Test Circuit and Timing

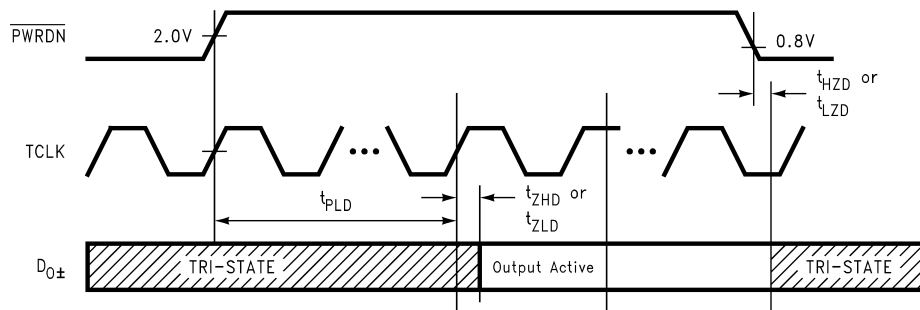

Figure 6. Serializer PLL Lock Time, and $\overline{\text{PWRDN}}$ TRI-STATE Delays

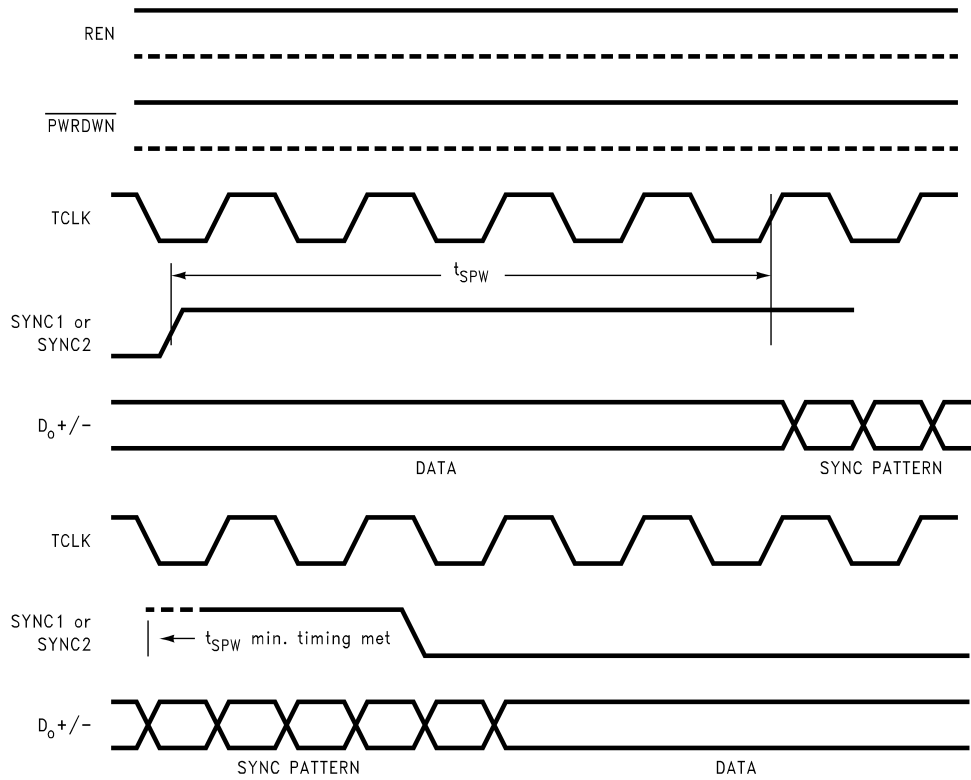

Figure 7. SYNC Timing Delay

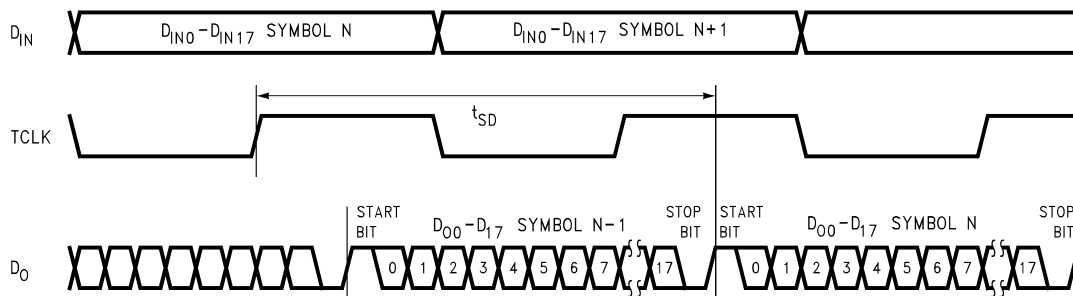

Figure 8. Serializer Delay

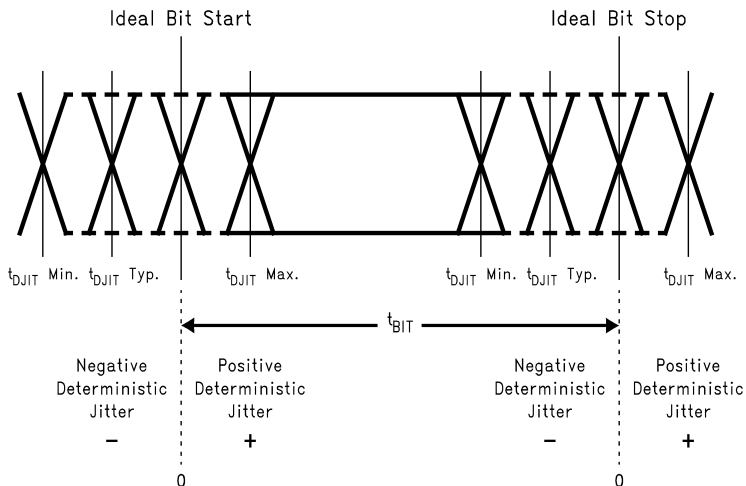
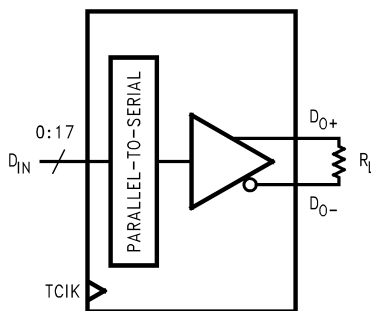

Figure 9. Deterministic Jitter and Ideal Bit Position



$V_{OD} = (DO+) - (DO-)$.
 Differential output signal is shown as $(DO+) - (DO-)$, device in Data Transfer mode.

Figure 10. V_{OD} Diagram

Pre-emphasis Truth Table

PEM LEVEL	PEM2	PEM1	PEM0
0	L	L	L
1	L	L	H
2	L	H	L
3	L	H	H
4	H	L	L
5	H	L	H
6	H	H	L
7	H	H	H

Pin Diagram

Figure 11. SCAN921821TVV
Top View

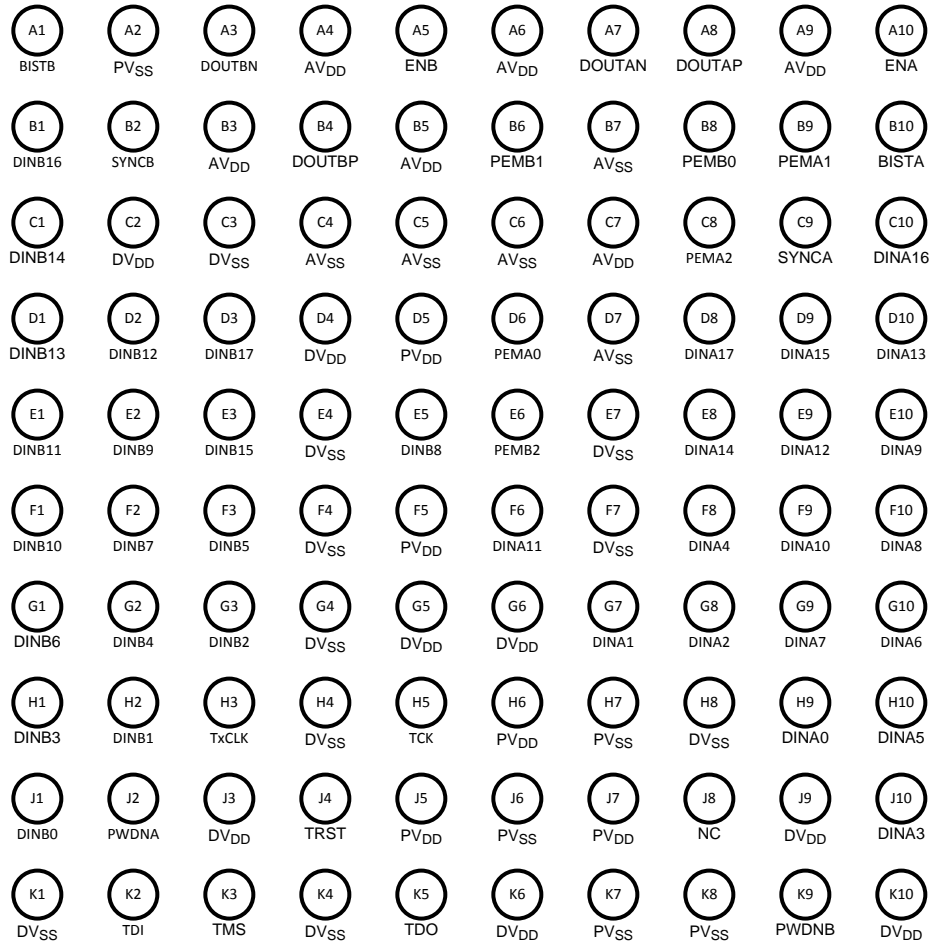

Pin Descriptions

Pin Name	Pin Count	I/O, Type	Description
DATA PINS			
DINA0-17	18	I, LVCMOS	Transmitter <u>inputs</u> . There is a pull-down circuitry on each of these pins which are active if respective <u>PWDNA</u> or <u>PWDNB</u> pin is pulled high.
DINB0-17	18		
DOUTAP	1	O,BLVDS	Inverting and non-inverting differential transmitter outputs.
DOUTAN	1		
DOUTBP	1		
DOUTAN	1		
TIMING AND CONTROL PINS			
TxCLK	1	I, LVCMOS	Transmitter reference clock. Used to strobe data at the inputs and to drive the transmitter PLL. There is a pull-up circuitry on this pin which is always active.
ENA	1	I, LVCMOS	Transmitter <u>outputs enable pins</u> . There is a pull-down circuitry on each of these pins that are active if corresponding <u>PWDNA</u> or <u>PWDNB</u> pin is pulled high. When these pins are set to LOW, the transmitter outputs will be disabled. The PLL will remain locked.
ENB	1		
<u>PWDNA</u>	1	I, LVCMOS	Stand-by mode pins. There is a pull-down circuitry on each of these pins that are always active. When these pins are set to LOW, the transmitter will be put in low power mode and the PLL will lose lock.
<u>PWDNB</u>	1		
SYNCA	1	I, LVCMOS	Transmitter synchronization pins. There is a pull-down circuitry on each of these pins that are active if corresponding <u>PWDNA</u> or <u>PWDNB</u> pin is pulled high. When these pins are set to HIGH, the transmitter will ignore incoming data and send SYNC patterns to provide a locking reference to receiver(s).
SYNCB	1		
PRE-EMPHASIS PINS			
PEMA0-2	3	I, LVCMOS	8-level pre-emphasis selection pins. There is a pull-down circuitry on each of these pins which are active if corresponding <u>PWDNA</u> or <u>PWDNB</u> pin is pulled high.
PEMB0-2	3		
JTAG PINS			
TDI	1	I, LVCMOS	Test Data Input to support IEEE 1149.1. There is a pull-up circuitry on this pin which is always active.
TDO	1	O, LVCMOS	Test Data Output to support IEEE 1149.1.
TMS	1	I, LVCMOS	Test Mode Select Input to support IEEE 1149.1. There is a pull-up circuitry on this pin which is always active.
TCK	1	I, LVCMOS	Test Clock Input to support IEEE 1149.1. There is no failsafe circuitry on this pin.
<u>TRST</u>	1	I, LVCMOS	Test Reset Input to support IEEE 1149.1. There is a pull-up circuitry on this pin which is always active.
BIST PINS			
BISTA	1	I, LVCMOS	BIST selection pins. These pins select which transmitter will generate a PRBS like data. There is a pull-down circuitry on these pins which are active if corresponding <u>PWDNA</u> or <u>PWDNB</u> pin is pulled high.
BISTB	1		
POWER PINS			
AVDD	6	I, POWER	Power Supply for the LVDS circuitry.
DVDD	8	I, POWER	Power Supply for the digital circuitry.
PVDD	5	I, POWER	Power Supply for the PLL and BG circuitry.
AVSS	5	I, POWER	Ground reference for the LVDS circuitry.
DVSS	10	I, POWER	Ground reference for the digital circuitry.
PVSS	5	I, POWER	Ground reference for the PLL and BG circuitry.
OTHER PINS			
NC	1	N/A	Not connected.

REVISION HISTORY

Changes from Revision B (April 2013) to Revision C	Page
• Changed layout of National Data Sheet to TI format	11

PACKAGING INFORMATION

Orderable Device	Status (1)	Package Type	Package Drawing	Pins	Package Qty	Eco Plan (2)	Lead/Ball Finish (6)	MSL Peak Temp (3)	Op Temp (°C)	Device Marking (4/5)	Samples
SCAN921821TSM/NOPB	ACTIVE	NFBGA	NZD	100	240	Green (RoHS & no Sb/Br)	SNAGCU	Level-4-260C-72 HR	-40 to 85	SCAN921821 TSM	Samples

(1) The marketing status values are defined as follows:

ACTIVE: Product device recommended for new designs.

LIFEBUY: TI has announced that the device will be discontinued, and a lifetime-buy period is in effect.

NRND: Not recommended for new designs. Device is in production to support existing customers, but TI does not recommend using this part in a new design.

PREVIEW: Device has been announced but is not in production. Samples may or may not be available.

OBSELETE: TI has discontinued the production of the device.

(2) Eco Plan - The planned eco-friendly classification: Pb-Free (RoHS), Pb-Free (RoHS Exempt), or Green (RoHS & no Sb/Br) - please check <http://www.ti.com/productcontent> for the latest availability information and additional product content details.

TBD: The Pb-Free/Green conversion plan has not been defined.

Pb-Free (RoHS): TI's terms "Lead-Free" or "Pb-Free" mean semiconductor products that are compatible with the current RoHS requirements for all 6 substances, including the requirement that lead not exceed 0.1% by weight in homogeneous materials. Where designed to be soldered at high temperatures, TI Pb-Free products are suitable for use in specified lead-free processes.

Pb-Free (RoHS Exempt): This component has a RoHS exemption for either 1) lead-based flip-chip solder bumps used between the die and package, or 2) lead-based die adhesive used between the die and leadframe. The component is otherwise considered Pb-Free (RoHS compatible) as defined above.

Green (RoHS & no Sb/Br): TI defines "Green" to mean Pb-Free (RoHS compatible), and free of Bromine (Br) and Antimony (Sb) based flame retardants (Br or Sb do not exceed 0.1% by weight in homogeneous material)

(3) MSL, Peak Temp. - The Moisture Sensitivity Level rating according to the JEDEC industry standard classifications, and peak solder temperature.

(4) There may be additional marking, which relates to the logo, the lot trace code information, or the environmental category on the device.

(5) Multiple Device Markings will be inside parentheses. Only one Device Marking contained in parentheses and separated by a "~" will appear on a device. If a line is indented then it is a continuation of the previous line and the two combined represent the entire Device Marking for that device.

(6) Lead/Ball Finish - Orderable Devices may have multiple material finish options. Finish options are separated by a vertical ruled line. Lead/Ball Finish values may wrap to two lines if the finish value exceeds the maximum column width.

Important Information and Disclaimer: The information provided on this page represents TI's knowledge and belief as of the date that it is provided. TI bases its knowledge and belief on information provided by third parties, and makes no representation or warranty as to the accuracy of such information. Efforts are underway to better integrate information from third parties. TI has taken and continues to take reasonable steps to provide representative and accurate information but may not have conducted destructive testing or chemical analysis on incoming materials and chemicals. TI and TI suppliers consider certain information to be proprietary, and thus CAS numbers and other limited information may not be available for release.

In no event shall TI's liability arising out of such information exceed the total purchase price of the TI part(s) at issue in this document sold by TI to Customer on an annual basis.

NZD0100A

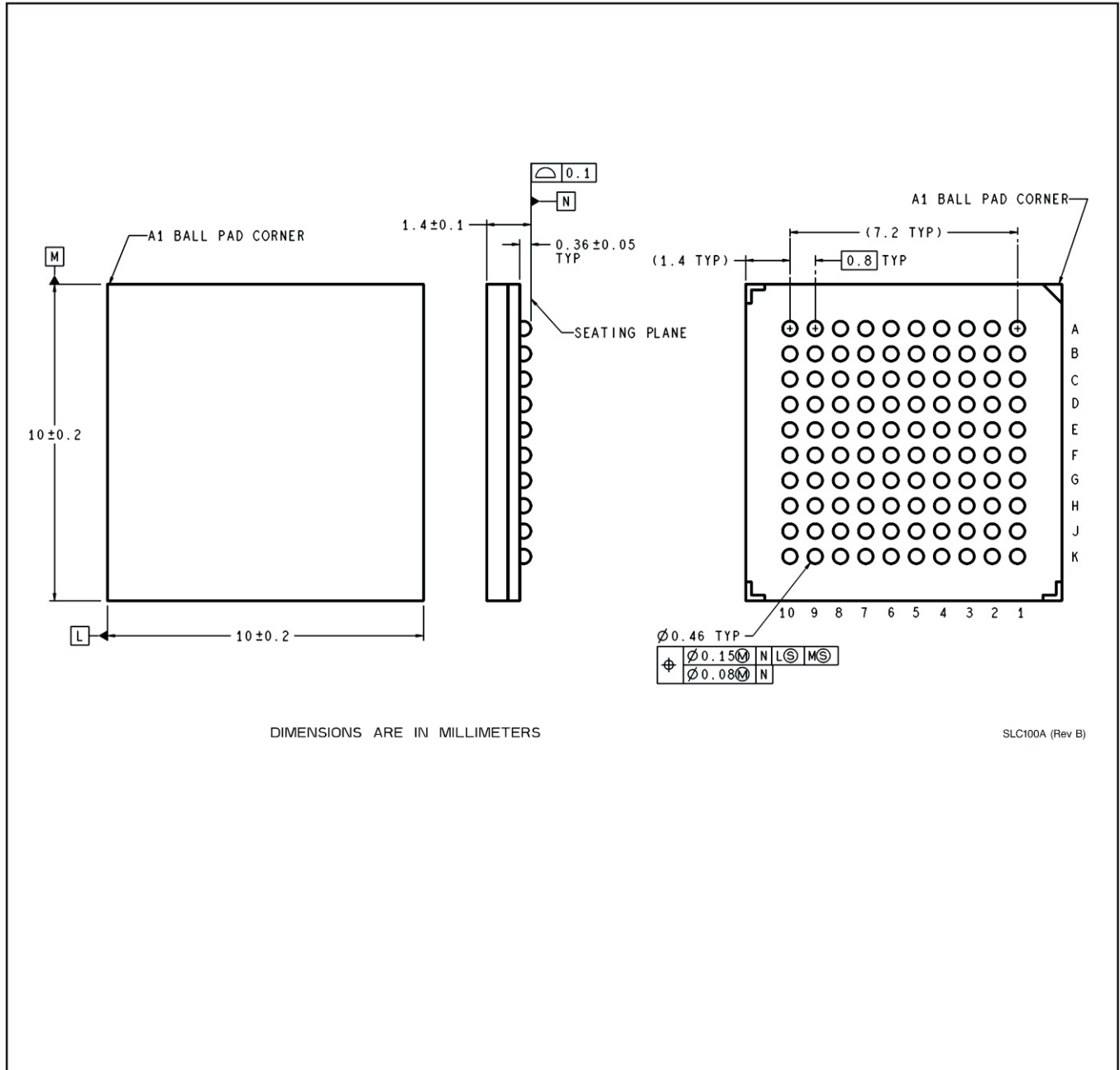

IMPORTANT NOTICE

Texas Instruments Incorporated and its subsidiaries (TI) reserve the right to make corrections, enhancements, improvements and other changes to its semiconductor products and services per JESD46, latest issue, and to discontinue any product or service per JESD48, latest issue. Buyers should obtain the latest relevant information before placing orders and should verify that such information is current and complete. All semiconductor products (also referred to herein as "components") are sold subject to TI's terms and conditions of sale supplied at the time of order acknowledgment.

TI warrants performance of its components to the specifications applicable at the time of sale, in accordance with the warranty in TI's terms and conditions of sale of semiconductor products. Testing and other quality control techniques are used to the extent TI deems necessary to support this warranty. Except where mandated by applicable law, testing of all parameters of each component is not necessarily performed.

TI assumes no liability for applications assistance or the design of Buyers' products. Buyers are responsible for their products and applications using TI components. To minimize the risks associated with Buyers' products and applications, Buyers should provide adequate design and operating safeguards.

TI does not warrant or represent that any license, either express or implied, is granted under any patent right, copyright, mask work right, or other intellectual property right relating to any combination, machine, or process in which TI components or services are used. Information published by TI regarding third-party products or services does not constitute a license to use such products or services or a warranty or endorsement thereof. Use of such information may require a license from a third party under the patents or other intellectual property of the third party, or a license from TI under the patents or other intellectual property of TI.

Reproduction of significant portions of TI information in TI data books or data sheets is permissible only if reproduction is without alteration and is accompanied by all associated warranties, conditions, limitations, and notices. TI is not responsible or liable for such altered documentation. Information of third parties may be subject to additional restrictions.

Resale of TI components or services with statements different from or beyond the parameters stated by TI for that component or service voids all express and any implied warranties for the associated TI component or service and is an unfair and deceptive business practice. TI is not responsible or liable for any such statements.

Buyer acknowledges and agrees that it is solely responsible for compliance with all legal, regulatory and safety-related requirements concerning its products, and any use of TI components in its applications, notwithstanding any applications-related information or support that may be provided by TI. Buyer represents and agrees that it has all the necessary expertise to create and implement safeguards which anticipate dangerous consequences of failures, monitor failures and their consequences, lessen the likelihood of failures that might cause harm and take appropriate remedial actions. Buyer will fully indemnify TI and its representatives against any damages arising out of the use of any TI components in safety-critical applications.

In some cases, TI components may be promoted specifically to facilitate safety-related applications. With such components, TI's goal is to help enable customers to design and create their own end-product solutions that meet applicable functional safety standards and requirements. Nonetheless, such components are subject to these terms.

No TI components are authorized for use in FDA Class III (or similar life-critical medical equipment) unless authorized officers of the parties have executed a special agreement specifically governing such use.

Only those TI components which TI has specifically designated as military grade or "enhanced plastic" are designed and intended for use in military/aerospace applications or environments. Buyer acknowledges and agrees that any military or aerospace use of TI components which have **not** been so designated is solely at the Buyer's risk, and that Buyer is solely responsible for compliance with all legal and regulatory requirements in connection with such use.

TI has specifically designated certain components as meeting ISO/TS16949 requirements, mainly for automotive use. In any case of use of non-designated products, TI will not be responsible for any failure to meet ISO/TS16949.

Products

Audio	www.ti.com/audio
Amplifiers	amplifier.ti.com
Data Converters	dataconverter.ti.com
DLP® Products	www.dlp.com
DSP	dsp.ti.com
Clocks and Timers	www.ti.com/clocks
Interface	interface.ti.com
Logic	logic.ti.com
Power Mgmt	power.ti.com
Microcontrollers	microcontroller.ti.com
RFID	www.ti-rfid.com
OMAP Applications Processors	www.ti.com/omap
Wireless Connectivity	www.ti.com/wirelessconnectivity

Applications

Automotive and Transportation	www.ti.com/automotive
Communications and Telecom	www.ti.com/communications
Computers and Peripherals	www.ti.com/computers
Consumer Electronics	www.ti.com/consumer-apps
Energy and Lighting	www.ti.com/energy
Industrial	www.ti.com/industrial
Medical	www.ti.com/medical
Security	www.ti.com/security
Space, Avionics and Defense	www.ti.com/space-avionics-defense
Video and Imaging	www.ti.com/video

TI E2E Community

e2e.ti.com

Looking for pricing, stock, or lifecycle information?

Click below to explore more details on WIN SOURCE:

- ⊖ [View SCAN921821TSM/NOPB on WIN SOURCE](#)
- ⊖ [Texas Instruments](#) Information

Optimize Your Supply Chain with WIN SOURCE Solutions

- ✓ Global Sourcing Solution
- ✓ Obsolete Management
- ✓ Cost Control Management
- ✓ Shortage Management
- ✓ Alternative Solution
- ✓ Excess Inventory Management