



**THE DATASHEET OF
CY7C0853V-133BBC**





CY7C0851V/CY7C0851AV
CY7C0852V/CY7C0852AV
CY7C0853V/CY7C0853AV

**FLEx36™ 3.3 V,
 32K/64K/128K/256K × 36
 Synchronous Dual-Port RAM**

Features

- True dual-ported memory cells that allow simultaneous access of the same memory location
- Synchronous pipelined operation
- Organization of 2-Mbit, 4-Mbit, and 9-Mbit devices
- Pipelined output mode allows fast operation
- 0.18-micron Complimentary metal oxide semiconductor (CMOS) for optimum speed and power
- High-speed clock to data access
- 3.3 V low power
 - Active as low as 225 mA (typ)
 - Standby as low as 55 mA (typ)
- Mailbox function for message passing
- Global master reset
- Separate byte enables on both ports
- Commercial and industrial temperature ranges
- IEEE 1149.1-compatible Joint test action group (JTAG) boundary scan
- 172-ball fine-pitch ball grid array (FBGA) (1 mm pitch) (15 mm × 15 mm)
- 176-pin thin quad plastic flatpack (TQFP) (24 mm × 24 mm × 1.4 mm)
- Counter wrap around control
 - Internal mask register controls counter wrap-around
 - Counter-interrupt flags to indicate wrap-around
 - Memory block retransmit operation
- Counter readback on address lines
- Mask register readback on address lines
- Dual chip enables on both ports for easy depth expansion

Functional Description

The FLEx36™ family includes 2M, 4M, and 9M pipelined, synchronous, true dual-port static RAMs that are high-speed, low-power 3.3 V CMOS. Two ports are provided, permitting independent, simultaneous access to any location in memory. The result of writing to the same location by more than one port at the same time is undefined. Registers on control, address, and data lines allow for minimal setup and hold time.

During a Read operation, data is registered for decreased cycle time. Each port contains a burst counter on the input address register. After externally loading the counter with the initial address, the counter increments the address internally (more details to follow). The internal Write pulse width is independent of the duration of the R/W input signal. The internal Write pulse is self-timed to allow the shortest possible cycle times.

A HIGH on \overline{CE}_0 or LOW on CE_1 for one clock cycle powers down the internal circuitry to reduce the static power consumption. One cycle with chip enables asserted is required to reactivate the outputs.

Additional features include: readback of burst-counter internal address value on address lines, counter-mask registers to control the counter wrap-around, counter interrupt (CNTINT) flags, readback of mask register value on address lines, retransmit functionality, interrupt flags for message passing, JTAG for boundary scan, and asynchronous Master Reset (MRST).

The CY7C0853V/CY7C0853AV device in this family has limited features. Please see [Address Counter and Mask Register Operations on page 9](#) for details.

For a complete list of related documentation, [click here](#).

Product Selection Guide

Density	2-Mbit (64K × 36)	4-Mbit (128K × 36)	9-Mbit (256K × 36)
Part number	CY7C0851V/CY7C0851AV	CY7C0852V/CY7C0852AV	CY7C0853V/CY7C0853AV
Max. speed (MHz)	167	167	133
Max. access time - clock to data (ns)	4.0	4.0	4.7
Typical operating current (mA)	225	225	270
Package	176-pin TQFP, 172-ball FBGA	176-pin TQFP, 172-ball FBGA	172-ball FBGA

Contents

Pin Configurations	4	Switching Waveforms	18
Pin Definitions	7	JTAG Timing	29
Functional Overview	8	Ordering Information	30
Master Reset	8	256K × 36 (9M) 3.3 V Synchronous	
Mailbox Interrupts	8	CY7C0853V/CY7C0853AV Dual-Port SRAM	30
Read/Write and Enable Operation (Any Port)	8	Ordering Code Definitions	30
Address Counter and Mask Register Operations	9	Package Diagrams	31
IEEE 1149.1 Serial Boundary Scan (JTAG)	13	Acronyms	34
Performing a TAP Reset	13	Document Conventions	34
Performing a Pause/Restart	13	Units of Measure	34
Identification Register Definitions	13	Document History Page	35
Scan Registers Sizes	13	Sales, Solutions, and Legal Information	38
Instruction Identification Codes	13	Worldwide Sales and Design Support	38
Maximum Ratings	14	Products	38
Operating Range	14	PSoC® Solutions	38
Electrical Characteristics	14	Cypress Developer Community	38
Capacitance	15	Technical Support	38
AC Test Load and Waveforms	15		
Switching Characteristics	16		

Pin Configurations

Figure 1. 172-ball BGA pinout (Top View)

	1	2	3	4	5	6	7	8	9	10	11	12	13	14
A	DQ32L	DQ30L	$\overline{\text{CNTINTL}}$	VSS	DQ13L	VDD	DQ11L	DQ11R	VDD	DQ13R	VSS	$\overline{\text{CNTINTR}}$	DQ30R	DQ32R
B	A0L	DQ33L	DQ29L	DQ17L	DQ14L	DQ12L	DQ9L	DQ9R	DQ12R	DQ14R	DQ17R	DQ29R	DQ33R	A0R
C	NC	A1L	DQ31L	DQ27L	$\overline{\text{INTL}}$	DQ15L	DQ10L	DQ10R	DQ15R	$\overline{\text{INTR}}$	DQ27R	DQ31R	A1R	NC
D	A2L	A3L	DQ35L	DQ34L	DQ28L	DQ16L	VSS	VSS	DQ16R	DQ28R	DQ34R	DQ35R	A3R	A2R
E	A4L	A5L	CE1L	$\overline{\text{B0L}}$	VDD	VSS			VDD	VDD	$\overline{\text{B0R}}$	CE1R	A5R	A4R
F	VDD	A6L	A7L	$\overline{\text{B1L}}$	VDD				VSS	$\overline{\text{B1R}}$	A7R	A6R	VDD	
G	$\overline{\text{OEL}}$	$\overline{\text{B2L}}$	$\overline{\text{B3L}}$	$\overline{\text{CE0L}}$	CY7C0851V/CY7C0851AV CY7C0852V/CY7C0851AV						$\overline{\text{CE0R}}$	$\overline{\text{B3R}}$	$\overline{\text{B2R}}$	$\overline{\text{OER}}$
H	VSS	$\overline{\text{R/WL}}$	A8L	CLKL							CLKR	A8R	$\overline{\text{R/WR}}$	VSS
J	A9L	A10L	VSS	$\overline{\text{ADSL}}$	VSS				VDD	$\overline{\text{ADSR}}$	$\overline{\text{MRST}}$	A10R	A9R	
K	A11L	A12L	A15L ^[2]	$\overline{\text{CNTRSTL}}$	VDD	VDD			VSS	VDD	$\overline{\text{CNTRSTR}}$	A15R ^[2]	A12R	A11R
L	$\overline{\text{CNT/MSKL}}$	A13L	$\overline{\text{CNTENL}}$	DQ26L	DQ25L	DQ19L	VSS	VSS	DQ19R	DQ25R	DQ26R	$\overline{\text{CNTENR}}$	A13R	$\overline{\text{CNT/MSKR}}$
M	A16L ^[2]	A14L	DQ22L	DQ18L	TDI	DQ7L	DQ2L	DQ2R	DQ7R	TCK	DQ18R	DQ22R	A14R	A16R ^[2]
N	DQ24L	DQ20L	DQ8L	DQ6L	DQ5L	DQ3L	DQ0L	DQ0R	DQ3R	DQ5R	DQ6R	DQ8R	DQ20R	DQ24R
P	DQ23L	DQ21L	TDO	VSS	DQ4L	VDD	DQ1L	DQ1R	VDD	DQ4R	VSS	TMS	DQ21R	DQ23R

Note

2. For CY7C0851V/CY7C0851AV, pins M1 and M14 are NC.

Pin Configurations (continued)

Figure 2. 172-ball BGA pinout (Top View)

	1	2	3	4	5	6	7	8	9	10	11	12	13	14
A	DQ32L	DQ30L	NC	VSS	DQ13L	VDD	DQ11L	DQ11R	VDD	DQ13R	VSS	NC	DQ30R	DQ32R
B	A0L	DQ33L	DQ29L	DQ17L	DQ14L	DQ12L	DQ9L	DQ9R	DQ12R	DQ14R	DQ17R	DQ29R	DQ33R	A0R
C	A17L	A1L	DQ31L	DQ27L	$\overline{\text{INTL}}$	DQ15L	DQ10L	DQ10R	DQ15R	$\overline{\text{INTR}}$	DQ27R	DQ31R	A1R	A17R
D	A2L	A3L	DQ35L	DQ34L	DQ28L	DQ16L	VSS	VSS	DQ16R	DQ28R	DQ34R	DQ35R	A3R	A2R
E	A4L	A5L	VDD	$\overline{\text{B0L}}$	VDD	VSS			VDD	VDD	$\overline{\text{B0R}}$	VDD	A5R	A4R
F	VDD	A6L	A7L	$\overline{\text{B1L}}$	VDD					VSS	$\overline{\text{B1R}}$	A7R	A6R	VDD
G	$\overline{\text{OEL}}$	$\overline{\text{B2L}}$	$\overline{\text{B3L}}$	VSS	CY7C0853V/CY7C0853AV						VSS	$\overline{\text{B3R}}$	$\overline{\text{B2R}}$	$\overline{\text{OER}}$
H	VSS	$\overline{\text{R/WL}}$	A8L	CLKL										
J	A9L	A10L	VSS	VSS	VSS					VDD	VSS	$\overline{\text{MRST}}$	A10R	A9R
K	A11L	A12L	A15L	VDD	VDD	VDD			VSS	VDD	VDD	A15R	A12R	A11R
L	VDD	A13L	VSS	DQ26L	DQ25L	DQ19L	VSS	VSS	DQ19R	DQ25R	DQ26R	VSS	A13R	VDD
M	A16L	A14L	DQ22L	DQ18L	TDI	DQ7L	DQ2L	DQ2R	DQ7R	TCK	DQ18R	DQ22R	A14R	A16R
N	DQ24L	DQ20L	DQ8L	DQ6L	DQ5L	DQ3L	DQ0L	DQ0R	DQ3R	DQ5R	DQ6R	DQ8R	DQ20R	DQ24R
P	DQ23L	DQ21L	TDO	VSS	DQ4L	VDD	DQ1L	DQ1R	VDD	DQ4R	VSS	TMS	DQ21R	DQ23R

Pin Configurations (continued)

Figure 3. 176-pin TQFP pinout (Top View)

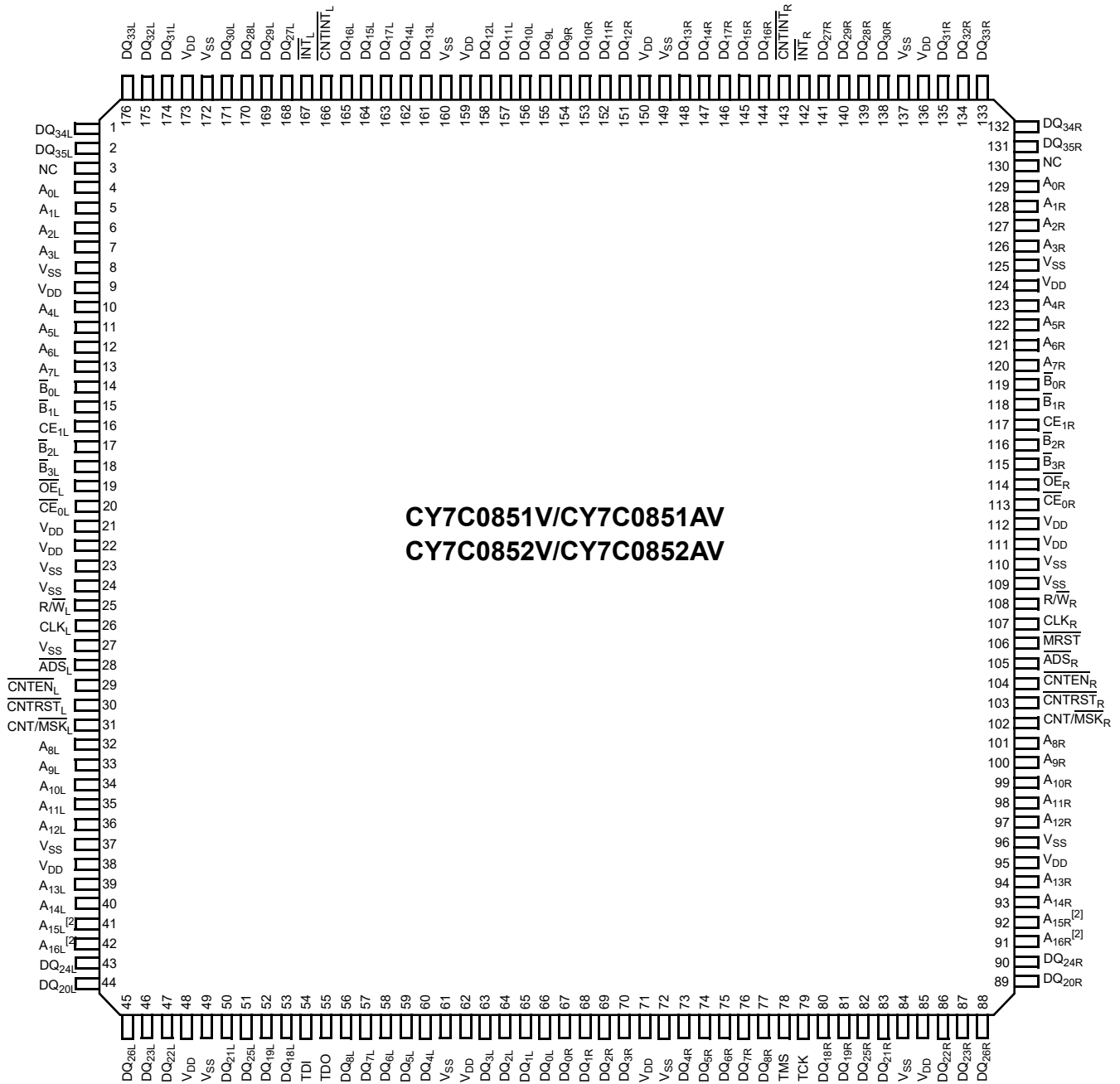

Pin Definitions

Left Port	Right Port	Description
A _{0L} –A _{17L} ^[3]	A _{0R} –A _{17R} ^[3]	Address inputs.
ADS _L ^[4]	ADS _R ^[4]	Address strobe input. Used as an address qualifier. This signal should be asserted LOW for the part using the externally supplied address on the address pins and for loading this address into the burst address counter.
CE _{0L} ^[4]	CE _{0R} ^[4]	Active LOW chip enable input.
CE _{1L} ^[4]	CE _{1R} ^[4]	Active HIGH chip enable input.
CLK _L	CLK _R	Clock signal. Maximum clock input rate is f _{MAX} .
CNTEN _L ^[4]	CNTEN _R ^[4]	Counter enable input. Asserting this signal LOW increments the <u>burst address counter</u> of its respective port on each rising edge of CLK. The increment is disabled if ADS or CNTRST are asserted LOW.
CNTRST _L ^[4]	CNTRST _R ^[4]	Counter reset input. Asserting this <u>signal LOW</u> resets to zero the <u>unmasked portion of the burst address counter</u> of its respective port. CNTRST is not disabled by asserting ADS or CNTEN.
CNT/MSK _L ^[4]	CNT/MSK _R ^[4]	Address counter mask register enable input. Asserting this signal LOW enables access to the mask register. When tied HIGH, the mask register is not accessible and the address counter operations are enabled based on the status of the counter control signals.
DQ _{0L} –DQ _{35L}	DQ _{0R} –DQ _{35R}	Data bus input/output.
OE _L	OE _R	Output enable input. This asynchronous signal must be asserted LOW to enable the DQ data pins during Read operations.
INT _L	INT _R	Mailbox interrupt flag output. The mailbox permits <u>communications</u> between ports. The upper two memory locations can be used for message passing. INT _L is asserted LOW when the right port writes to the mailbox location of the left port, and vice versa. An interrupt to a port is deasserted HIGH when it reads the contents of its mailbox.
CNTINT _L ^[4]	CNTINT _R ^[4]	Counter interrupt output. This pin is asserted LOW when the unmasked portion of the counter is incremented to all “1s.”
R/W _L	R/W _R	Read/Write enable input. Assert this pin LOW to write to, or HIGH to Read from the dual port memory array.
B _{0L} –B _{3L}	B _{0R} –B _{3R}	Byte select inputs. Asserting these signals enables Read and Write operations to the corresponding bytes of the memory array.
MRST		Master reset input. MRST is an asynchronous input signal and <u>affects both ports</u> . Asserting MRST LOW performs all of the reset functions as described in the text. A MRST operation is required at power up.
TMS		JTAG test mode select input. It controls the advance of JTAG TAP state machine. State machine transitions occur on the rising edge of TCK.
TDI		JTAG test data input. Data on the TDI input is shifted serially into selected registers.
TCK		JTAG test clock input.
TDO		JTAG test data output. TDO transitions occur on the falling edge of TCK. TDO is normally three-stated except when captured data is shifted out of the JTAG TAP.
V _{SS}		Ground inputs.
V _{DD}		Power inputs.

Notes

3. 9M device has 18 address bits, 4M device has 17 address bits, and 2M device has 16 address bits.
4. These pins are not available for CY7C0853V/CY7C0853AV device.

Functional Overview

Master Reset

The FLE_x36 family devices undergo a complete reset by taking its MRST input LOW. The MRST input can switch asynchronously to the clocks. The MRST initializes the internal burst counters to zero, and the counter mask registers to all ones (completely unmasked). The MRST also forces the Mailbox Interrupt (INT) flags and the Counter Interrupt (CNTINT) flags HIGH. The MRST must be performed on the FLE_x36 family devices after power up.

Mailbox Interrupts

The upper two memory locations may be used for message passing and permit communications between ports. Table 1 shows the interrupt operation for both ports of CY7C853V/CY7C0853AV. The highest memory location, 3FFFF

is the mailbox for the right port and 3FFFE is the mailbox for the left port. Table 1 shows that in order to set the INT_R flag, a Write operation by the left port to address 3FFFF asserts INT_R LOW. At least one byte has to be active for a Write to generate an interrupt. A valid Read of the 3FFFF location by the right port resets INT_R HIGH. At least one byte has to be active in order for a Read to reset the interrupt. When one port Writes to the other port's mailbox, the INT of the port that the mailbox belongs to is asserted LOW. The INT is reset when the owner (port) of the mailbox Reads the contents of the mailbox. The interrupt flag is set in a flow-thru mode (that is it follows the clock edge of the writing port). Also, the flag is reset in a flow-thru mode (that is it follows the clock edge of the reading port).





Each port can read the other port's mailbox without resetting the interrupt. And each port can write to its own mailbox without setting the interrupt. If an application does not require message passing, INT pins should be left open.

Table 1. Interrupt Operation Example [5, 6, 7, 8, 9]

Function	Left Port				Right Port			
	R/W _L	CE _L	A _{0L-17L}	INT _L	R/W _R	CE _R	A _{0R-17R}	INT _R
Set right INT _R flag	L	L	3FFFF	X	X	X	X	L
Reset right INT _R flag	X	X	X	X	H	L	3FFFF	H
Set left INT _L flag	X	X	X	L	L	L	3FFFE	X
Reset left INT _L flag	H	L	3FFFE	H	X	X	X	X

Read/Write and Enable Operation (Any Port)

Table 2. Read/Write and Enable Operation (Any Port) [12, 13, 10, 11]

Inputs					Outputs	Operation
OE	CLK	CE ₀	CE ₁	R/W	DQ ₀ -DQ ₃₅	
X		H	X	X	High Z	Deselected
X		X	L	X	High Z	Deselected
X		L	H	L	D _{IN}	Write
L		L	H	H	D _{OUT}	Read
H	X	L	H	X	High Z	Outputs disabled

Notes

- 9M device has 18 address bits, 4M device has 17 address bits, and 2M device has 16 address bits.
- CE is internal signal. CE = LOW if CE₀ = LOW and CE₁ = HIGH. For a single Read operation, CE only needs to be asserted once at the rising edge of the CLK and can be deasserted after that. Data is out after the following CLK edge and is three-stated after the next CLK edge.
- OE is "Don't Care" for mailbox operation.
- At least one of B₀, B₁, B₂, or B₃ must be LOW.
- A16x is a NC for CY7C0851V/CY7C0851AV, therefore the Interrupt Addresses are FFFF and FFFE.
- OE is an asynchronous input signal.
- When CE changes state, deselection and Read happen after one cycle of latency.
- 9 M device has 18 address bits, 4M device has 17 address bits, and 2M device has 16 address bits.
- "X" = "Don't Care", "H" = HIGH, "L" = LOW.

Address Counter and Mask Register Operations

This section^[14] describes the features only apply to CY7C0851V/CY7C0851AV/CY7C0852V/CY7C0852AV devices, but not to the CY7C0853V/CY7C0853AV device. Each port of these devices has a programmable burst address counter. The burst counter contains three registers: a counter register, a mask register, and a mirror register.

The **counter register** contains the address used to access the RAM array. It is changed only by the Counter Load, Increment, Counter Reset, and by master reset (MRST) operations.









The **mask register** value affects the Increment and Counter Reset operations by preventing the corresponding bits of the counter register from changing. It also affects the counter interrupt output (CNTINT). The mask register is changed only by the Mask Load and Mask Reset operations, and by the MRST. The mask register defines the counting range of the counter register. It divides the counter register into two regions: zero or more "0s" in the most significant bits define the masked region, one or more "1s" in the least significant bits define the unmasked region. Bit 0 may also be "0", masking the least significant counter bit and causing the counter to increment by two instead of one.

The **mirror register** is used to reload the counter register on increment operations (see "retransmit", below). It always contains the value last loaded into the counter register, and is changed only by the Counter Load operation, and by the MRST.

Table 3 summarizes the operation of these registers and the required input control signals. The MRST control signal is asynchronous. All the other control signals in Table 3 (CNT/MSK, CNTRST, ADS, CNTEN) are synchronized to the port's CLK. All these counter and mask operations are independent of the port's chip enable inputs (CE0 and CE1).

Counter enable (CNTEN) inputs are provided to stall the operation of the address input and utilize the internal address generated by the internal counter for fast, interleaved memory applications. A port's burst counter is loaded when the port's address strobe (ADS) and CNTEN signals are LOW. When the port's CNTEN is asserted and the ADS is deasserted, the address counter increments on each LOW to HIGH transition of that port's clock signal. This will Read/Write one word from/into each successive address location until CNTEN is deasserted. The counter can address the entire memory array, and loops back to the start. Counter reset (CNTRST) is used to reset the unmasked portion of the burst counter to 0s. A counter-mask register is used to control the counter wrap.

Table 3. Address Counter and Counter-Mask Register Control Operation (Any Port) ^[15, 16]

CLK	MRST	CNT/MSK	CNTRST	ADS	CNTEN	Operation	Description
X	L	X	X	X	X	Master reset	Reset address counter to all 0s and mask register to all 1s.
	H	H	L	X	X	Counter reset	Reset counter unmasked portion to all 0s.
	H	H	H	L	L	Counter load	Load counter with external address value presented on address lines.
	H	H	H	L	H	Counter readback	Read out counter internal value on address lines.
	H	H	H	H	L	Counter increment	Internally increment address counter value.
	H	H	H	H	H	Counter hold	Constantly hold the address value for multiple clock cycles.
	H	L	L	X	X	Mask reset	Reset mask register to all 1s.
	H	L	H	L	L	Mask load	Load mask register with value presented on the address lines.
	H	L	H	L	H	Mask readback	Read out mask register value on address lines.
	H	L	H	H	X	Reserved	Operation undefined

Notes

- 14. This section describes the CY7C0852V/CY7C0852AV, which have 17 address bits and a maximum address value of 1FFFF. The CY7C0851V/CY7C0851AV has 16 address bits, register lengths of 16 bits, and a maximum address value of FFFF.
- 15. "X" = "Don't Care," "H" = HIGH, "L" = LOW.
- 16. Counter operation and mask register operation is independent of chip enables.

Counter Reset Operation

All unmasked bits of the counter are reset to “0”. All masked bits remain unchanged. The mirror register is loaded with the value of the burst counter. A Mask Reset followed by a Counter Reset will reset the counter and mirror registers to 00000, as will master reset ($\overline{\text{MRST}}$).

Counter Load Operation

The address counter and mirror registers are both loaded with the address value presented at the address lines.

Counter Readback Operation

The internal value of the counter register can be read out on the address lines. Readback is pipelined; the address is valid t_{CA2} after the next rising edge of the port's clock. If address readback occurs while the port is enabled (CE0 LOW and CE1 HIGH), the data lines (DQs) is three-stated. [Figure 4 on page 11](#) shows a block diagram of the operation.

Counter Increment Operation

Once the address counter register is initially loaded with an external address, the counter can internally increment the address value, potentially addressing the entire memory array. Only the unmasked bits of the counter register are incremented. The corresponding bit in the mask register must be a “1” for a counter bit to change. The counter register is incremented by 1 if the least significant bit is unmasked, and by 2 if it is masked. If all unmasked bits are “1”, the next increment wraps the counter back to the initially loaded value. If an Increment results in all the unmasked bits of the counter being “1s”, a counter interrupt flag (CNTINT) is asserted. The next Increment returns the counter register to its initial value, which was stored in the mirror register. The counter address can instead be forced to loop to 00000 by externally connecting CNTINT to $\overline{\text{CNTRST}}^{[17]}$. An increment that results in one or more of the unmasked bits of the counter being “0” deasserts the counter interrupt flag. The example in [Figure 5 on page 12](#) shows the counter mask register loaded with a mask value of 0003Fh unmasking the first 6 bits with bit “0” as the LSB and bit “16” as the MSB. The maximum value the mask register can be loaded with is 1FFFFh. Setting the mask register to this value allows the counter to access the entire memory space. The address counter is then loaded with an initial value of 8h. The base address bits (in this case, the 6th address through the 16th address) are loaded with an address value but do not increment once the counter is configured for increment operation. The counter address starts at address 8h. The counter increments its internal address value till it reaches the mask register value of 3Fh. The counter wraps around the memory block to location 8h at the next count. CNTINT is issued when the counter reaches its maximum value.

Counter Hold Operation

The value of all three registers can be constantly maintained unchanged for an unlimited number of clock cycles. Such operation is useful in applications where wait states are needed, or when address is available a few cycles ahead of data in a shared bus interface.

Counter Interrupt

The counter interrupt ($\overline{\text{CNTINT}}$) is asserted LOW when an increment operation results in the unmasked portion of the counter register being all “1s”. It is deasserted HIGH when an Increment operation results in any other value. It is also de-asserted by Counter Reset, Counter Load, Mask Reset and Mask Load operations, and by MRST.

Retransmit

Retransmit is a feature that allows the Read of a block of memory more than once without the need to reload the initial address. This eliminates the need for external logic to store and route data. It also reduces the complexity of the system design and saves board space. An internal “mirror register” is used to store the initially loaded address counter value. When the counter unmasked portion reaches its maximum value set by the mask register, it wraps back to the initial value stored in this “mirror register”. If the counter is continuously configured in increment mode, it increments again to its maximum value and wraps back to the value initially stored into the “mirror register”. Thus, the repeated access of the same data is allowed without the need for any external logic.

Mask Reset Operation

The mask register is reset to all “1s”, which unmask every bit of the counter. Master reset ($\overline{\text{MRST}}$) also resets the mask register to all “1s”.

Mask Load Operation

The mask register is loaded with the address value presented at the address lines. Not all values permit correct increment operations. Permitted values are of the form $2^n - 1$ or $2^n - 2$. From the most significant bit to the least significant bit, permitted values have zero or more “0s”, one or more “1s”, or one “0”. Thus 1FFFF, 003FE, and 00001 are permitted values, but 1FOFF, 003FC, and 00000 are not.

Mask Readback Operation

The internal value of the mask register can be read out on the address lines. Readback is pipelined; the address is valid t_{CM2} after the next rising edge of the port's clock. If mask readback occurs while the port is enabled (CE0 LOW and CE1 HIGH), the data lines (DQs) is three-stated. [Figure 4 on page 11](#) shows a block diagram of the operation.

Counting by Two

When the least significant bit of the mask register is “0”, the counter increments by two. This may be used to connect the CY7C0851V/CY7C0851AV/CY7C0852V/CY7C0852AV as a 72-bit single port SRAM in which the counter of one port counts even addresses and the counter of the other port counts odd addresses. This even-odd address scheme stores one half of the 72-bit data in even memory locations, and the other half in odd memory locations.

Note

17. CNTINT and CNTRST specs are guaranteed by design to operate properly at speed grade operating frequency when tied together.

Figure 4. Counter, Mask, and Mirror Logic Block Diagram ^[18]

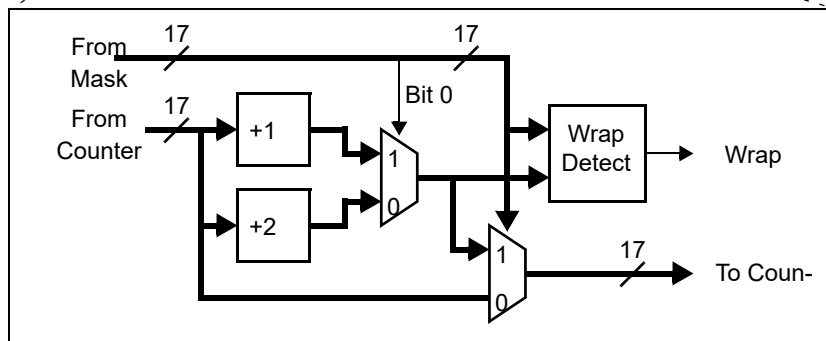
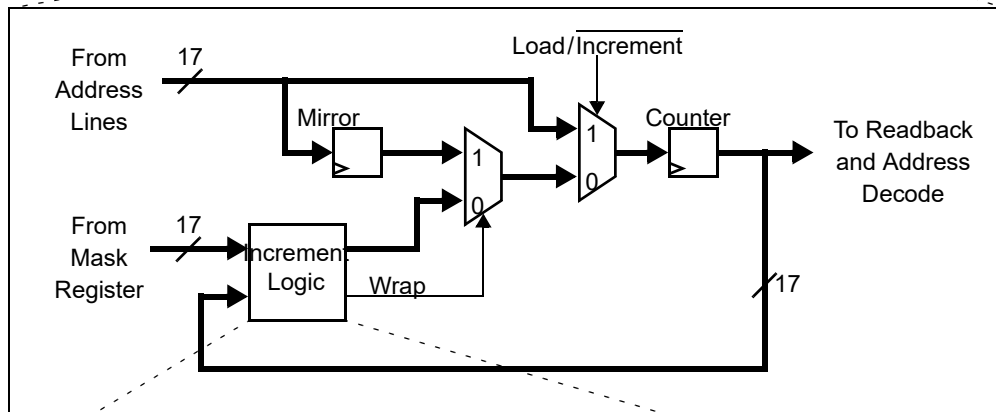
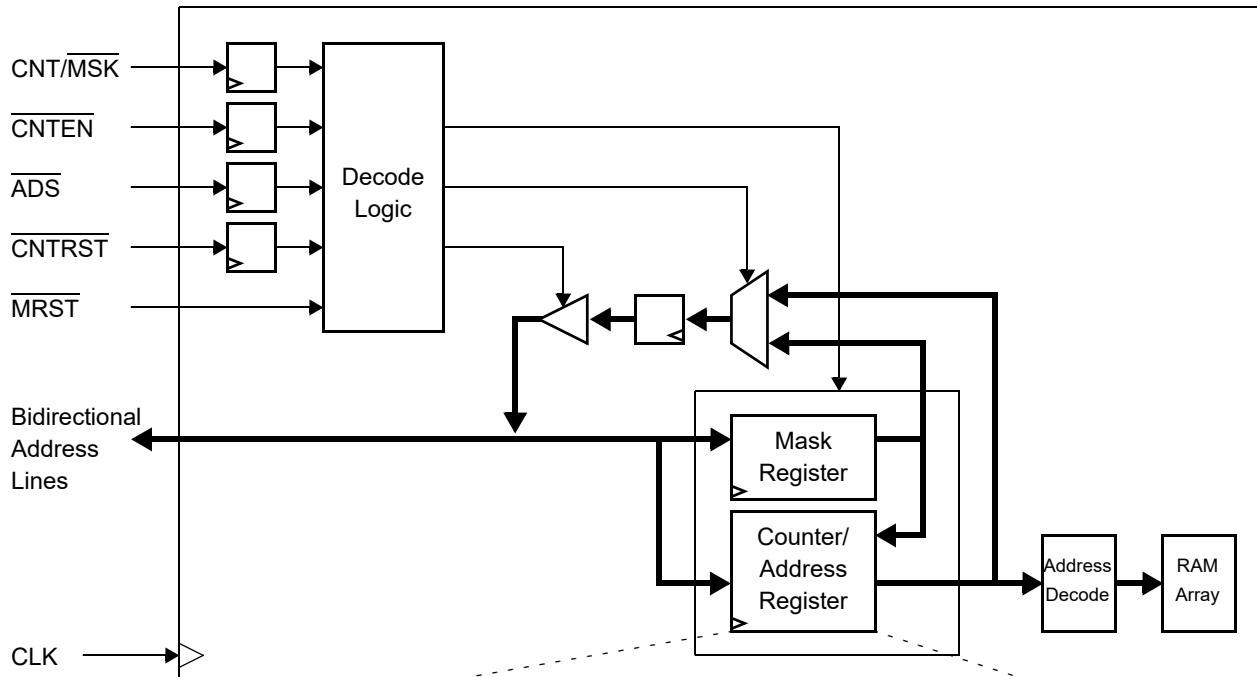

Note

18. 9M device has 18 address bits, 4M device has 17 address bits, and 2M device has 16 address bits.

IEEE 1149.1 Serial Boundary Scan (JTAG)

The CY7C0851V/CY7C0851AV/CY7C0852V/CY7C0852AV/ CY7C0853V/CY7C0853AV incorporates an IEEE 1149.1 serial boundary scan ^[21] test access port (TAP). The TAP controller functions in a manner that does not conflict with the operation of other devices using 1149.1-compliant TAPs. The TAP operates using JEDEC-standard 3.3 V I/O logic levels. It is composed of three input connections and one output connection required by the test logic defined by the standard.

Performing a TAP Reset

A reset is performed by forcing TMS HIGH (V_{DD}) for five rising edges of TCK. This reset does not affect the operation of the devices, and may be performed while the devices are operating. An MRST must be performed on the devices after power-up.

Performing a Pause/Restart

When a SHIFT-DR PAUSE-DR SHIFT-DR is performed the scan chain outputs the next bit in the chain twice. For example, if the value expected from the chain is 1010101, the device outputs a 11010101. This extra bit causes some testers to report an erroneous failure for the devices in a scan test. Therefore the tester should be configured to never enter the PAUSE-DR state.

Identification Register Definitions

Instruction Field	Value	Description
Revision number (31:28)	0h	Reserved for version number.
Cypress device ID (27:12)	C001h	Defines Cypress part number for the CY7C0851V/CY7C0851AV
	C002h	Defines Cypress part number for the CY7C0852V/CY7C0852AV and CY7C0853V/CY7C0853AV
Cypress JEDEC ID (11:1)	034h	Allows unique identification of the DP family device vendor.
ID register presence (0)	1	Indicates the presence of an ID register.

Scan Registers Sizes

Register Name	Bit Size
Instruction	4
Bypass	1
Identification	32
Boundary Scan	$n^{[22]}$

Instruction Identification Codes

Instruction	Code	Description
EXTEST	0000	Captures the Input/Output ring contents. Places the BSR between the TDI and TDO.
BYPASS	1111	Places the BYR between TDI and TDO.
IDCODE	1011	Loads the IDR with the vendor ID code and places the register between TDI and TDO.
HIGHZ	0111	Places BYR between TDI and TDO. Forces all CY7C0851AV / CY7C0852AV / CY7C0853AV output drivers to a High Z state.
CLAMP	0100	Controls boundary to 1/0. Places BYR between TDI and TDO.
SAMPLE/PRELOAD	1000	Captures the input/output ring contents. Places BSR between TDI and TDO.
NBSRST	1100	Resets the non-boundary scan logic. Places BYR between TDI and TDO.
RESERVED	All other codes	Other combinations are reserved. Do not use other than the above.

Notes

21. Boundary scan is IEEE 1149.1-compatible. See "Performing a Pause/Restart" for deviation from strict 1149.1 compliance.
 22. See details in the device BSDL files.

Maximum Ratings

Exceeding maximum ratings^[23] may impair the useful life of the device. These user guidelines are not tested.

Storage temperature	-65 °C to + 150 °C
Ambient temperature with power applied	-55 °C to + 125 °C
Supply voltage to ground potential	-0.5 V to + 4.6 V
DC voltage applied to outputs in High Z state	-0.5 V to $V_{DD} + 0.5 V$

DC input voltage	-0.5 V to $V_{DD} + 0.5 V$ ^[24]
Output current into outputs (LOW)	20 mA
Static discharge voltage (JEDEC JESD22-A114-2000B)	> 2000 V
Latch-up current	> 200 mA

Operating Range

Range	Ambient Temperature	V_{DD}
Commercial	0 °C to +70 °C	3.3 V ± 165 mV
Industrial	-40 °C to +85 °C	3.3 V ± 165 mV

Electrical Characteristics

Over the Operating Range

Parameter	Description	-167			-133			-100			Unit	
		Min	Typ	Max	Min	Typ	Max	Min	Typ	Max		
V_{OH}	Output HIGH voltage ($V_{DD} = \text{Min.}, I_{OH} = -4.0 \text{ mA}$)	2.4	-	-	2.4	-	-	2.4	-	-	V	
V_{OL}	Output LOW voltage ($V_{DD} = \text{Min.}, I_{OL} = +4.0 \text{ mA}$)	-	-	0.4	-	-	0.4	-	-	0.4	V	
V_{IH}	Input HIGH voltage	2.0	-	-	2.0	-	-	2.0	-	-	V	
V_{IL}	Input LOW voltage	-	-	0.8	-	-	0.8	-	-	0.8	V	
I_{OZ}	Output leakage current	-10	-	10	-10	-	10	-10	-	10	μA	
I_{IX1}	Input leakage current except TDI, TMS, $\overline{\text{MRST}}$	-10	-	10	-10	-	10	-10	-	10	μA	
I_{IX2}	Input leakage current TDI, TMS, $\overline{\text{MRST}}$	-0.1	-	1.0	-0.1	-	1.0	-0.1	-	1.0	mA	
I_{CC}	Operating current for ($V_{DD} = \text{Max.}, I_{OUT} = 0 \text{ mA}$), Outputs disabled	CY7C0851V / CY7C0851AV / CY7C0852V / CY7C0852AV		-	225	300	-	225	300	-	-	mA
		CY7C0853V / CY7C0853AV		-	-	-	-	270	400	-	200	310
I_{SB1} ^[25]	Standby current (both ports TTL level) CE_L and $CE_R \geq V_{IH}, f = f_{MAX}$	-	90	115	-	90	115	-	90	115	mA	
I_{SB2} ^[25]	Standby current (one port TTL level) $CE_L \mid CE_R \geq V_{IH}, f = f_{MAX}$	-	160	210	-	160	210	-	160	210	mA	
I_{SB3} ^[25]	Standby current (both ports CMOS level) CE_L and $CE_R \geq V_{DD} - 0.2 \text{ V}, f = 0$	-	55	75	-	55	75	-	55	75	mA	
I_{SB4} ^[25]	Standby current (one port CMOS level) $CE_L \mid CE_R \geq V_{IH}, f = f_{MAX}$	-	160	210	-	160	210	-	160	210	mA	
I_{SB5}	Operating current ($V_{DD} = \text{Max.}, I_{OUT} = 0 \text{ mA}, f = 0$) Outputs disabled	-	-	-	-	70	100	-	70	100	mA	

Notes

23. The voltage on any input or I/O pin can not exceed the power pin during power-up.

24. Pulse width < 20 ns.

25. I_{SB1} , I_{SB2} , I_{SB3} and I_{SB4} are not applicable for CY7C0853V/CY7C0853AV because it can not be powered down by using chip enable pins.

Capacitance

Part Number ^[26]	Parameter	Description	Test Conditions	Max	Unit
CY7C0851V/CY7C0851AV/ CY7C0852V/CY7C0852AV	C _{IN}	Input capacitance	T _A = 25 °C, f = 1 MHz, V _{DD} = 3.3 V	13	pF
	C _{OUT}	Output capacitance		10	pF
CY7C0853V/CY7C0853AV	C _{IN}	Input capacitance		22	pF
	C _{OUT}	Output capacitance		20	pF

AC Test Load and Waveforms

Figure 6. AC Test Load and Waveforms

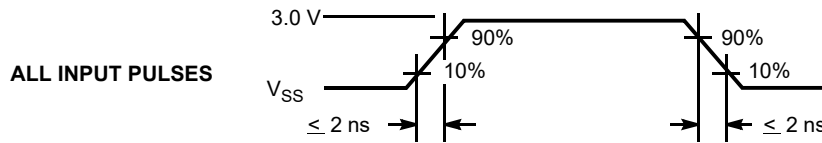
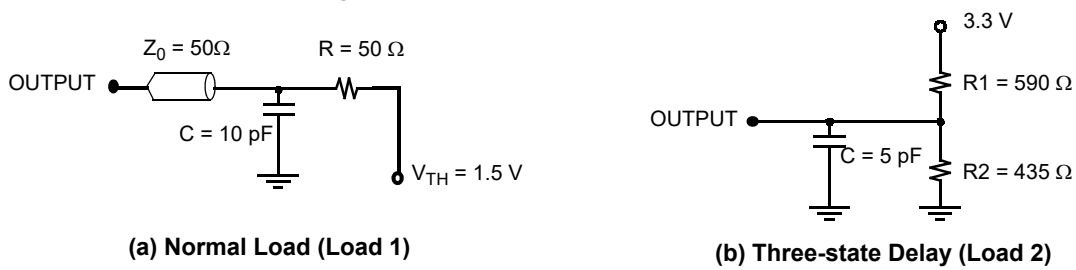

Note

26. C_{OUT} also references C_{I/O}.

Switching Characteristics

Over the Operating Range

Parameter	Description	-167		-133				-100		Unit
		CY7C0851V/ CY7C0851AV/ CY7C0852V/ CY7C0852AV		CY7C0851V/ CY7C0851AV/ CY7C0852V/ CY7C0852AV		CY7C0853V/ CY7C0853AV		CY7C0853V/ CY7C0853AV		
		Min	Max	Min	Max	Min	Max	Min	Max	
f_{MAX2}	Maximum operating frequency	–	167	–	133	–	133	–	100	MHz
t_{CYC2}	Clock cycle time	6.0	–	7.5	–	7.5	–	10.0	–	ns
t_{CH2}	Clock HIGH time	2.7	–	3.0	–	3.0	–	4.0	–	ns
t_{CL2}	Clock LOW time	2.7	–	3.0	–	3.0	–	4.0	–	ns
$t_R^{[27]}$	Clock rise time	–	2.0	–	2.0	–	2.0	–	3.0	ns
$t_F^{[27]}$	Clock fall time	–	2.0	–	2.0	–	2.0	–	3.0	ns
t_{SA}	Address setup time	2.3	–	2.5	–	2.5	–	3.0	–	ns
t_{HA}	Address hold time	0.6	–	0.6	–	0.6	–	0.6	–	ns
t_{SB}	Byte select setup time	2.3	–	2.5	–	2.5	–	3.0	–	ns
t_{HB}	Byte select hold time	0.6	–	0.6	–	0.6	–	0.6	–	ns
t_{SC}	Chip enable setup time	2.3	–	2.5	–	NA	–	NA	–	ns
t_{HC}	Chip enable hold time	0.6	–	0.6	–	NA	–	NA	–	ns
t_{SW}	R/W setup time	2.3	–	2.5	–	2.5	–	3.0	–	ns
t_{HW}	R/W hold time	0.6	–	0.6	–	0.6	–	0.6	–	ns
t_{SD}	Input data setup time	2.3	–	2.5	–	2.5	–	3.0	–	ns
t_{HD}	Input data hold time	0.6	–	0.6	–	0.6	–	0.6	–	ns
t_{SAD}	ADS setup time	2.3	–	2.5	–	NA	–	NA	–	ns
t_{HAD}	ADS hold time	0.6	–	0.6	–	NA	–	NA	–	ns
t_{SCN}	CNTEN setup time	2.3	–	2.5	–	NA	–	NA	–	ns
t_{HCN}	CNTEN hold time	0.6	–	0.6	–	NA	–	NA	–	ns
t_{SRST}	CNTRST setup time	2.3	–	2.5	–	NA	–	NA	–	ns
t_{HRST}	CNTRST hold time	0.6	–	0.6	–	NA	–	NA	–	ns
t_{SCM}	CNT/MSK setup time	2.3	–	2.5	–	NA	–	NA	–	ns
t_{HCM}	CNT/MSK hold time	0.6	–	0.6	–	NA	–	NA	–	ns
t_{OE}	Output enable to data valid	–	4.0	–	4.4	–	4.7	–	5.0	ns
$t_{OLZ}^{[28, 29]}$	OE to Low Z	0	–	0	–	0	–	0	–	ns
$t_{OHZ}^{[28, 29]}$	OE to High Z	0	4.0	0	4.4	0	4.7	0	5.0	ns

Notes

27. Except JTAG signals (t_r and $t_f < 10$ ns [max.]).
 28. This parameter is guaranteed by design, but it is not production tested.
 29. Test conditions used are Load 2.

Switching Characteristics (continued)

Over the Operating Range

Parameter	Description	-167		-133				-100		Unit
		CY7C0851V/ CY7C0851AV/ CY7C0852V/ CY7C0852AV		CY7C0851V/ CY7C0851AV/ CY7C0852V/ CY7C0852AV		CY7C0853V/ CY7C0853AV		CY7C0853V/ CY7C0853AV		
		Min	Max	Min	Max	Min	Max	Min	Max	
t _{CD2}	Clock to data valid	–	4.0	–	4.4	–	4.7	–	5.0	ns
t _{CA2}	Clock to counter address valid	–	4.0	–	4.4	–	NA	–	NA	ns
t _{CM2}	Clock to mask register readback valid	–	4.0	–	4.4	–	NA	–	NA	ns
t _{DC}	Data output hold after clock HIGH	1.0	–	1.0	–	1.0	–	1.0	–	ns
t _{CKHZ} ^[30, 31]	Clock HIGH to output High Z	0	4.0	0	4.4	0	4.7	0	5.0	ns
t _{CKLZ} ^[30, 31]	Clock HIGH to output Low Z	1.0	4.0	1.0	4.4	1.0	4.7	1.0	5.0	ns
t _{SINT}	Clock to $\overline{\text{INT}}$ set time	0.5	6.7	0.5	7.5	0.5	7.5	0.5	10	ns
t _{RINT}	Clock to $\overline{\text{INT}}$ reset time	0.5	6.7	0.5	7.5	0.5	7.5	0.5	10	ns
t _{SCINT}	Clock to $\overline{\text{CNTINT}}$ set time	0.5	5.0	0.5	5.7	NA	NA	NA	NA	ns
t _{RCINT}	Clock to $\overline{\text{CNTINT}}$ reset time	0.5	5.0	0.5	5.7	NA	NA	NA	NA	ns
Port to Port Delays										
t _{CCS}	Clock to clock skew	5.2	–	6.0	–	6.0	–	8.0	–	ns
Master Reset Timing										
t _{RS}	Master reset pulse width	7.0	–	7.5	–	7.5	–	10.0	–	ns
t _{RSS}	Master reset setup time	6.0	–	6.0	–	6.0	–	8.5	–	ns
t _{RSR}	Master reset recovery time	6.0	–	7.5	–	7.5	–	10.0	–	ns
t _{RSF}	Master reset to outputs inactive	–	10.0	–	10.0	–	10.0	–	10.0	ns
t _{RSCNTINT}	Master reset to counter interrupt flag reset time	–	10.0	–	10.0	–	NA	–	NA	ns

Notes

30. This parameter is guaranteed by design, but it is not production tested.
 31. Test conditions used are Load 2.

Switching Waveforms

Figure 7. Master Reset

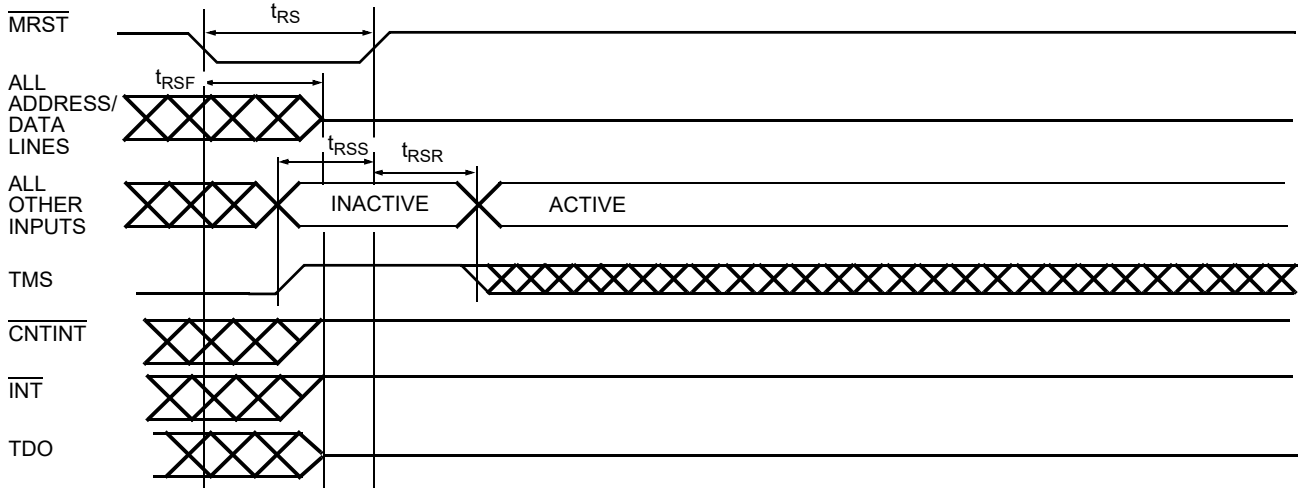
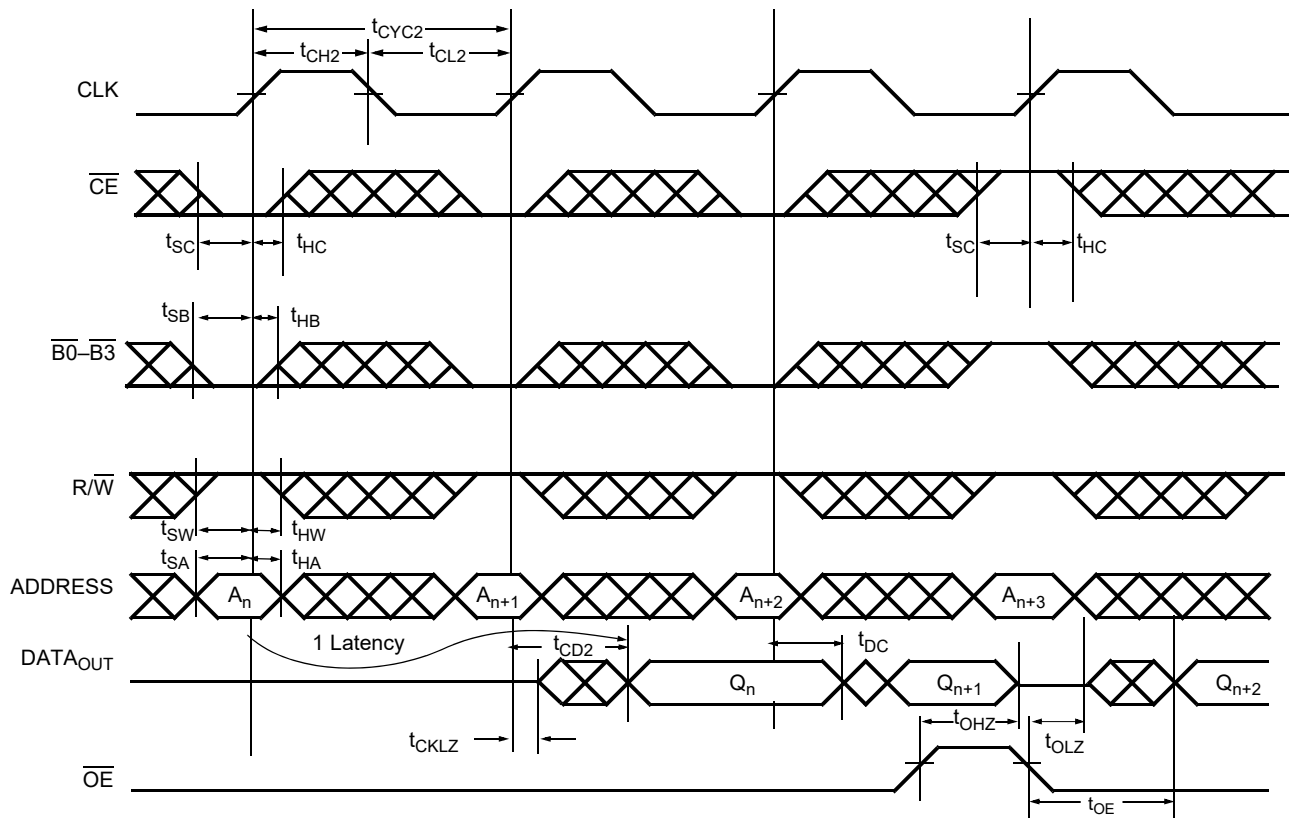

Figure 8. Read Cycle [32, 33, 34, 35, 36]



Notes

32. $\overline{\text{CE}}$ is internal signal. $\overline{\text{CE}} = \text{LOW}$ if $\overline{\text{CE}}_0 = \text{LOW}$ and $\text{CE}_1 = \text{HIGH}$. For a single Read operation, $\overline{\text{CE}}$ only needs to be asserted once at the rising edge of the CLK and can be deasserted after that. Data is out after the following CLK edge and is three-stated after the next CLK edge.
33. $\overline{\text{OE}}$ is asynchronously controlled; all other inputs (excluding $\overline{\text{MRST}}$ and JTAG) are synchronous to the rising clock edge.
34. $\text{ADS} = \text{CNTEN} = \text{LOW}$, and $\overline{\text{MRST}} = \text{CNTRST} = \text{CNT/MSK} = \text{HIGH}$.
35. The output is disabled (high-impedance state) by $\overline{\text{CE}} = V_{\text{IH}}$ following the next rising edge of the clock.
36. Addresses do not have to be accessed sequentially since $\text{ADS} = \text{CNTEN} = V_{\text{IL}}$ with $\text{CNT/MSK} = V_{\text{IH}}$ constantly loads the address on the rising edge of the CLK. Numbers are for reference only.

Switching Waveforms (continued)

Figure 9. Bank Select Read [37, 38]

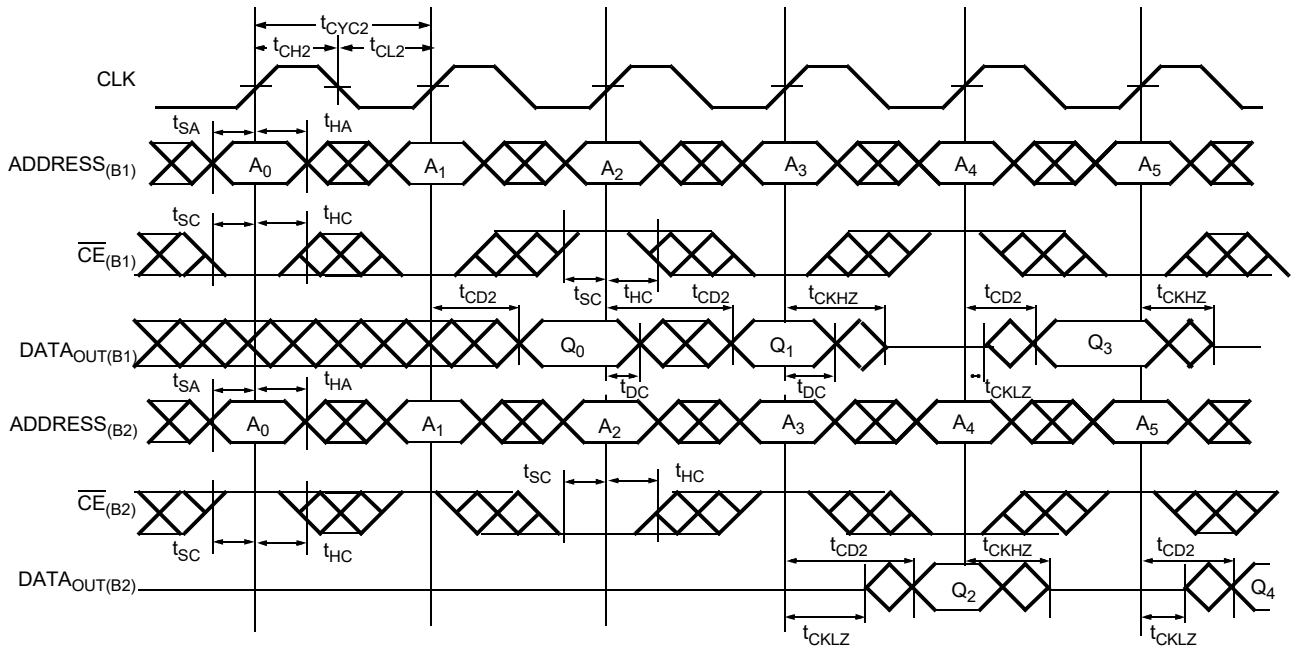
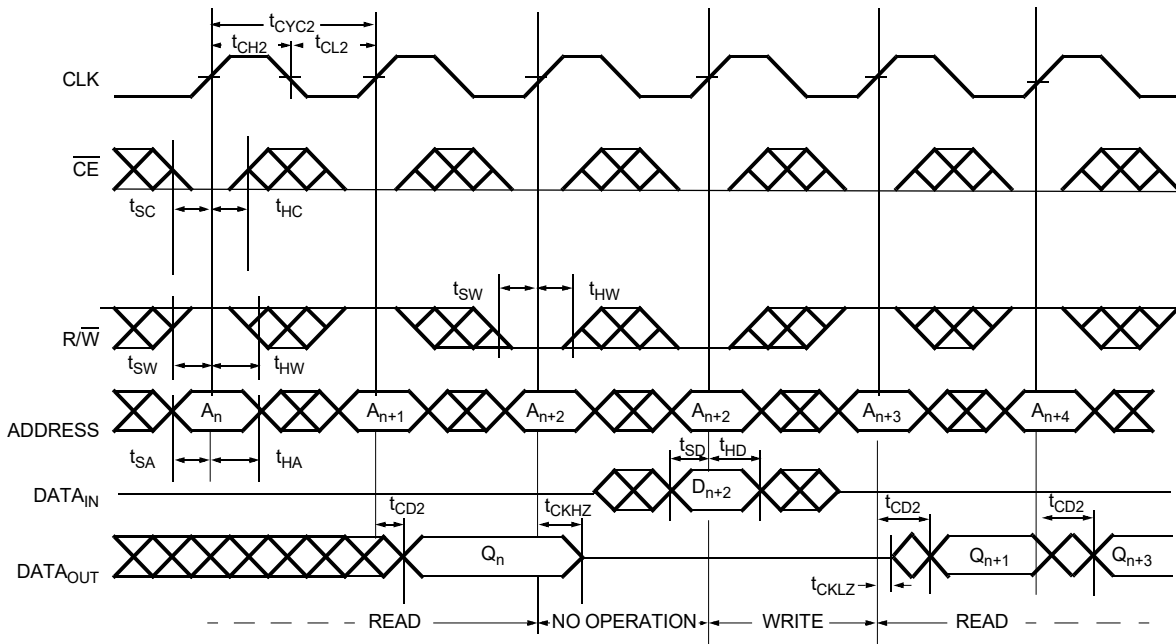

Figure 10. Read-to-Write-to-Read ($\overline{OE} = \text{LOW}$) [36, 39, 40, 41, 42]



Notes

- 37. In this depth-expansion example, B1 represents Bank #1 and B2 is Bank #2; each bank consists of one Cypress CY7C0851V/CY7C0851AV/CY7C0852V/CY7C0852AV device from this data sheet. ADDRESS_(B1) = ADDRESS_(B2).
- 38. $\overline{ADS} = \overline{CNTEN} = \overline{B0-B3} = \overline{OE} = \text{LOW}$; $\overline{MRST} = \overline{CNRST} = \overline{CNT/MSK} = \text{HIGH}$.
- 39. Output state (HIGH, LOW, or high-impedance) is determined by the previous cycle control signals.
- 40. During "No Operation," data in memory at the selected address may be corrupted and should be rewritten to ensure data integrity.
- 41. $\overline{CE}_0 = \overline{OE} = \overline{B0-B3} = \text{LOW}$; $\overline{CE}_1 = \overline{R/W} = \overline{CNRST} = \overline{MRST} = \text{HIGH}$.
- 42. $\overline{CE}_0 = \overline{B0-B3} = \overline{R/W} = \text{LOW}$; $\overline{CE}_1 = \overline{CNRST} = \overline{MRST} = \overline{CNT/MSK} = \text{HIGH}$. When $\overline{R/W}$ first switches low, since $\overline{OE} = \text{LOW}$, the Write operation cannot be completed (labelled as no operation). One clock cycle is required to three-state the I/O for the Write operation on the next rising edge of CLK.

Switching Waveforms (continued)

Figure 11. Read-to-Write-to-Read (\overline{OE} Controlled) [43, 44, 45, 46]

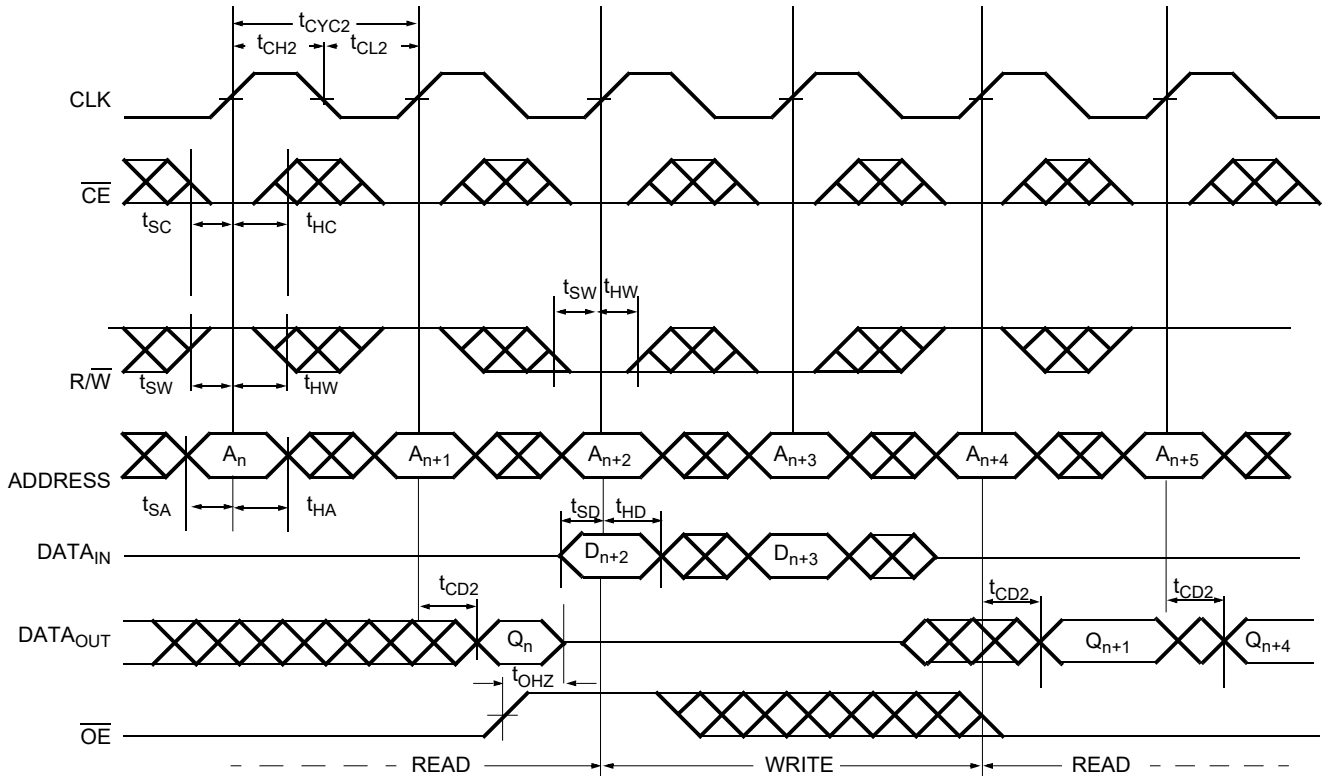
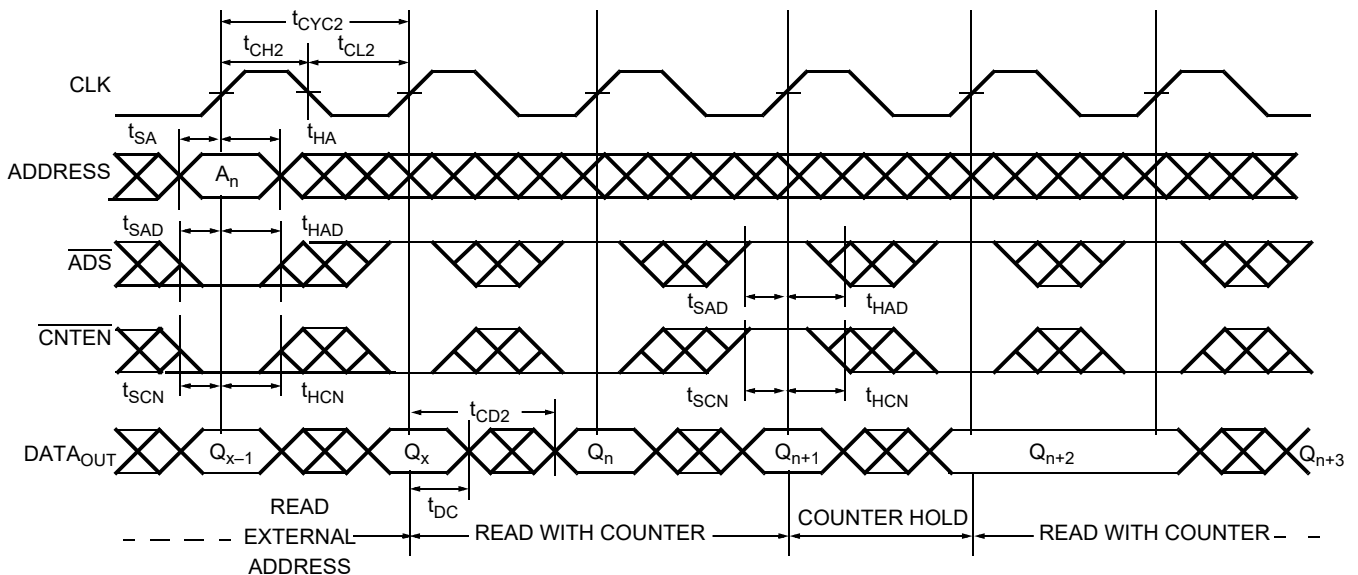

Figure 12. Read with Address Counter Advance [45]



Notes

43. Addresses do not have to be accessed sequentially since $\overline{ADS} = \overline{CNTEN} = V_{IL}$ with $\overline{CNT}/\overline{MSK} = V_{IH}$ constantly loads the address on the rising edge of the CLK. Numbers are for reference only
44. Output state (HIGH, LOW, or high-impedance) is determined by the previous cycle control signals.
45. $\overline{CE}_0 = \overline{OE} = \overline{B0-B3} = \text{LOW}$; $\overline{CE}_1 = \overline{R/W} = \overline{CNTRST} = \overline{MRST} = \text{HIGH}$.
46. $\overline{CE}_0 = \overline{B0-B3} = \overline{R/W} = \text{LOW}$; $\overline{CE}_1 = \overline{CNTRST} = \overline{MRST} = \overline{CNT}/\overline{MSK} = \text{HIGH}$. When $\overline{R/W}$ first switches low, since $\overline{OE} = \text{LOW}$, the Write operation cannot be completed (labelled as no operation). One clock cycle is required to three-state the I/O for the Write operation on the next rising edge of CLK.

Switching Waveforms (continued)

Figure 13. Write with Address Counter Advance [47]

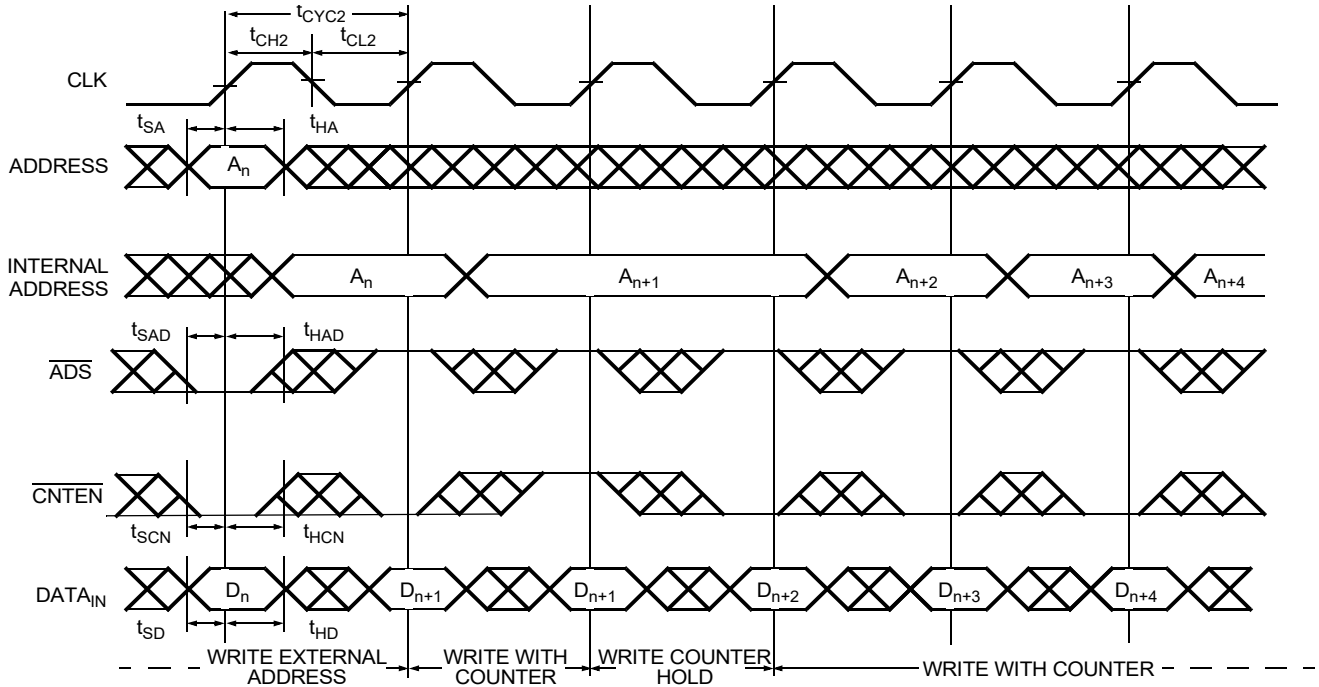
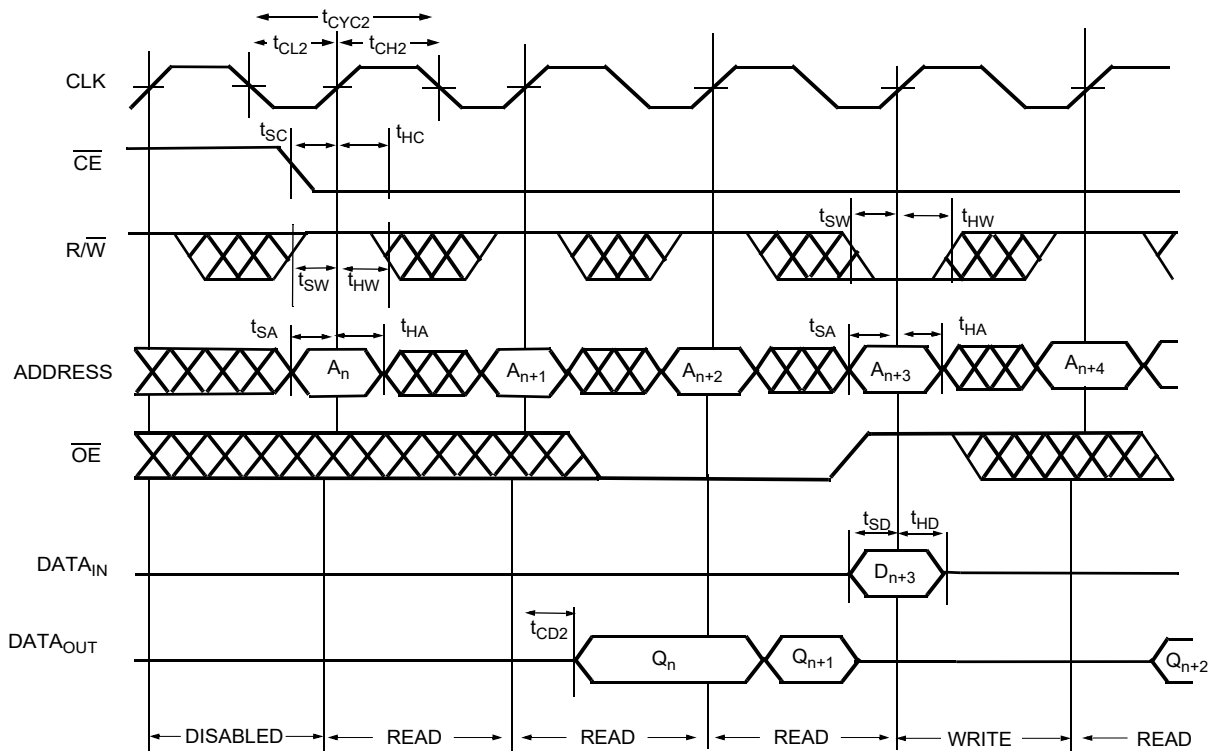

Figure 14. Disabled to Read-to-Read to Read-to-Write



Note

47. $\overline{CE}_0 = \overline{B0-B3} = \overline{R/W} = \text{LOW}$; $\overline{CE}_1 = \overline{CNTRST} = \overline{MRST} = \overline{CNT/MSK} = \text{HIGH}$. When $\overline{R/W}$ first switches low, since $\overline{OE} = \text{LOW}$, the Write operation cannot be completed (labelled as no operation). One clock cycle is required to three-state the I/O for the Write operation on the next rising edge of CLK.

Switching Waveforms (continued)

Figure 15. Disabled to Write-to-Read to Write-to-Read

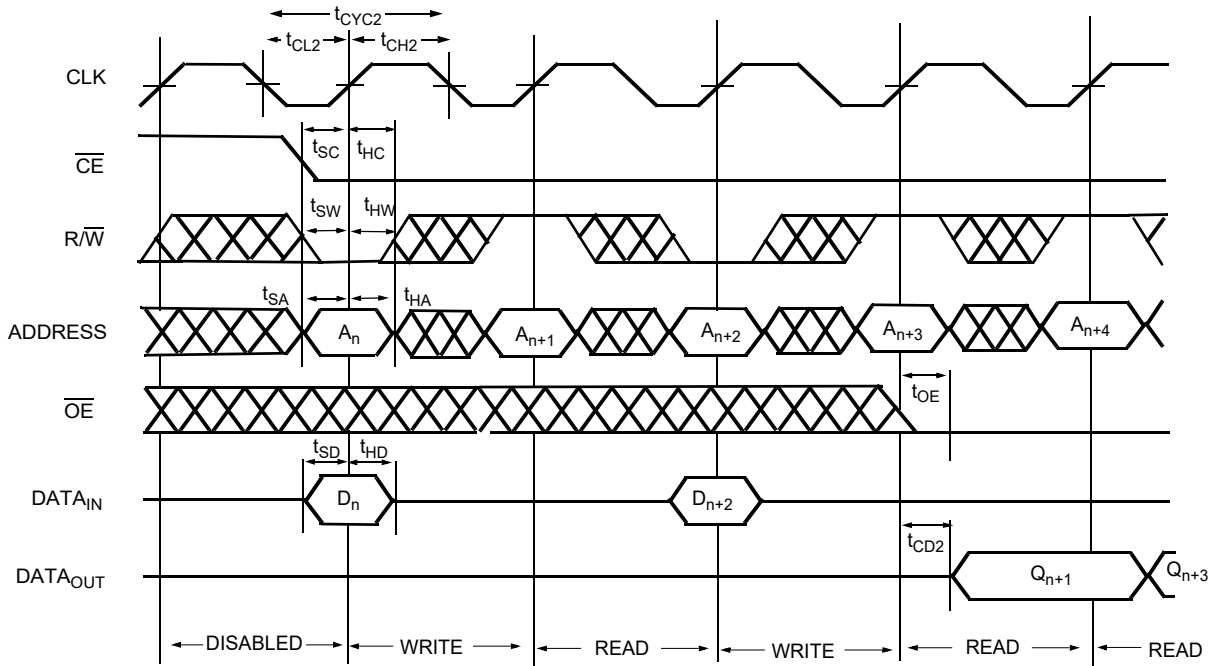
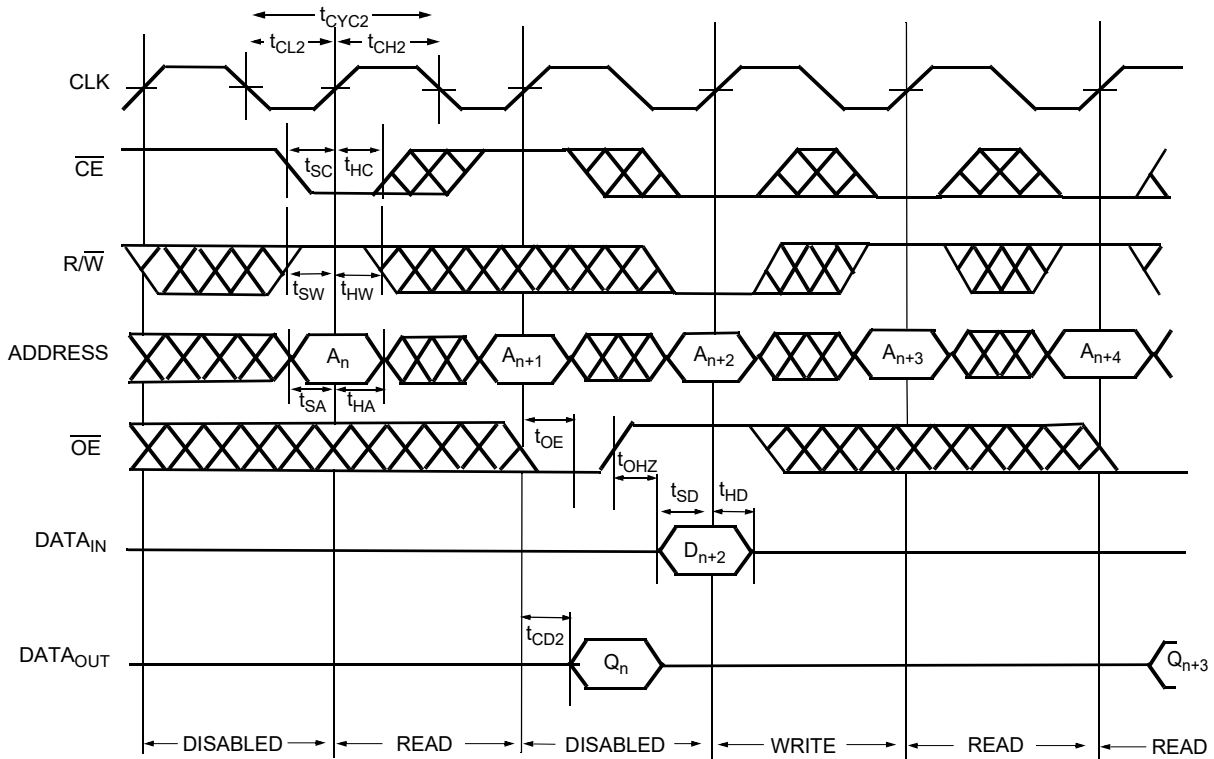
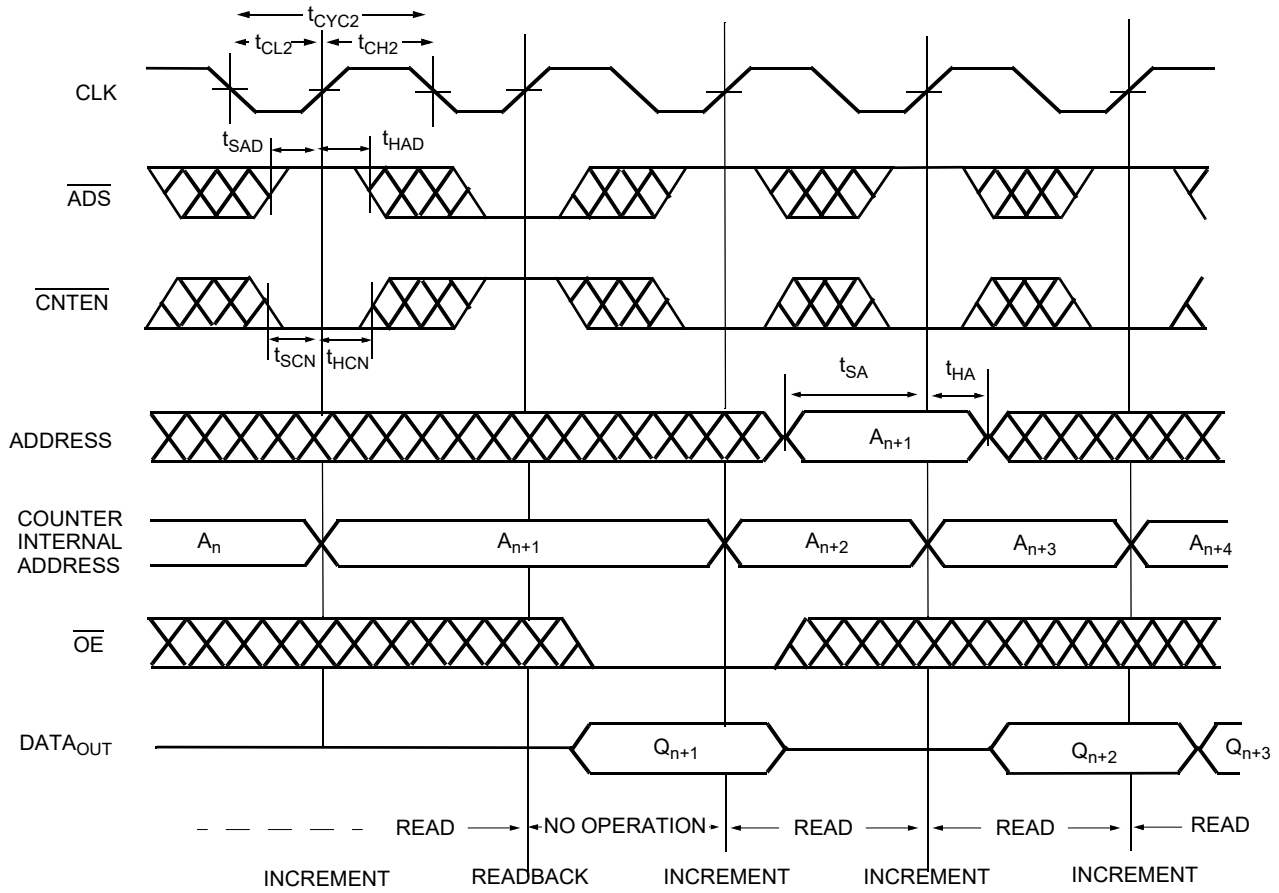

Figure 16. Disabled-to-Read to Disabled-to-Write



Switching Waveforms (continued)

Figure 17. Read-to-Readback to Read-to-Read ($\overline{R/W} = \text{HIGH}$)



Switching Waveforms (continued)

Figure 18. Counter Reset [48, 49, 50]

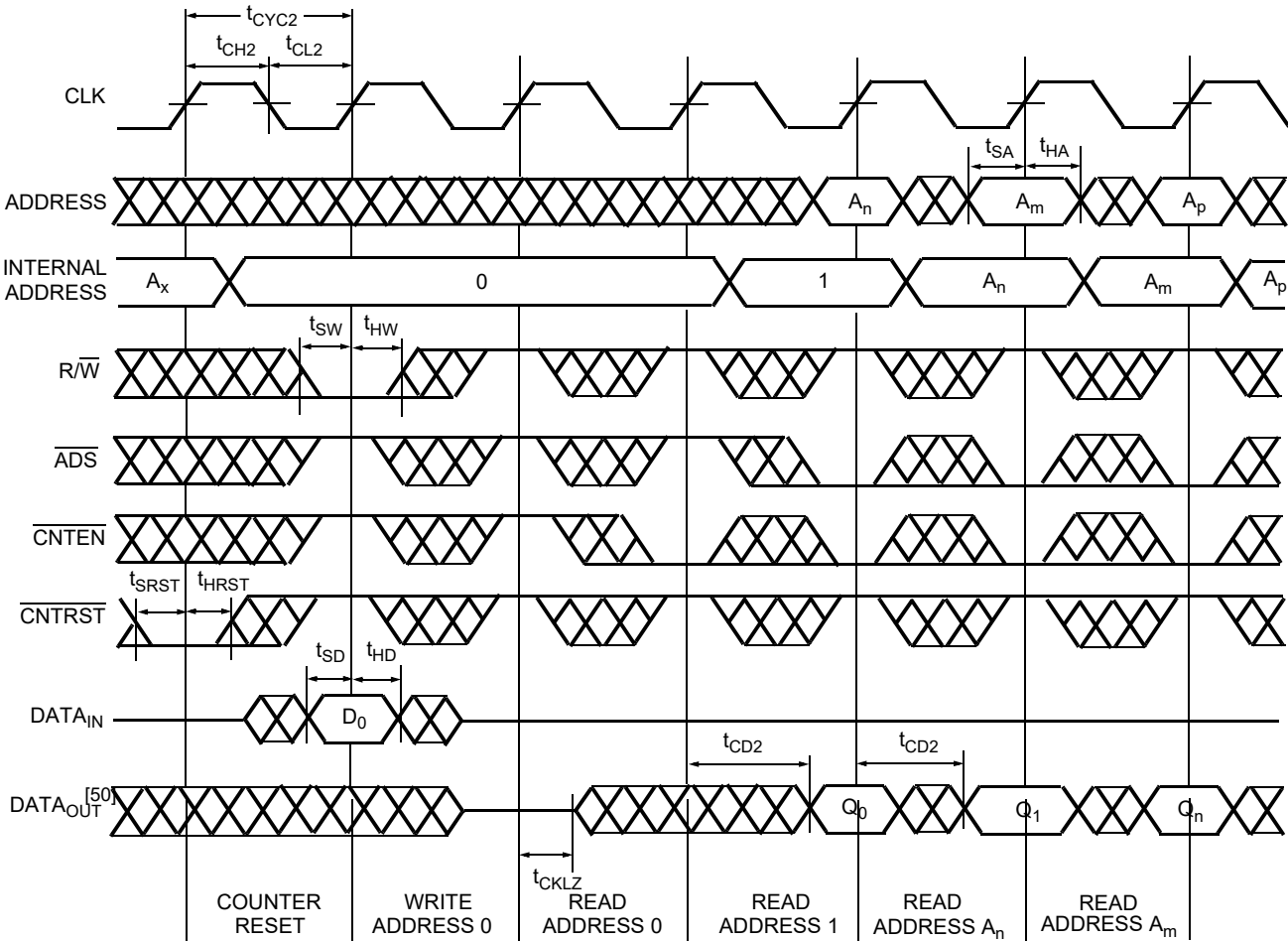

Notes

- 48. $\overline{CE}_0 = \overline{B}_0\text{--}\overline{B}_3 = \text{LOW}$; $\overline{CE}_1 = \overline{MRST} = \overline{CNT/MSK} = \text{HIGH}$.
- 49. No dead cycle exists during counter reset. A Read or Write cycle may be coincidental with the counter reset.
- 50. Retransmit happens if the counter remains in increment mode after it wraps to initially loaded value.

Switching Waveforms (continued)

Figure 19. Readback State of Address Counter or Mask Register [51, 52, 53, 54]

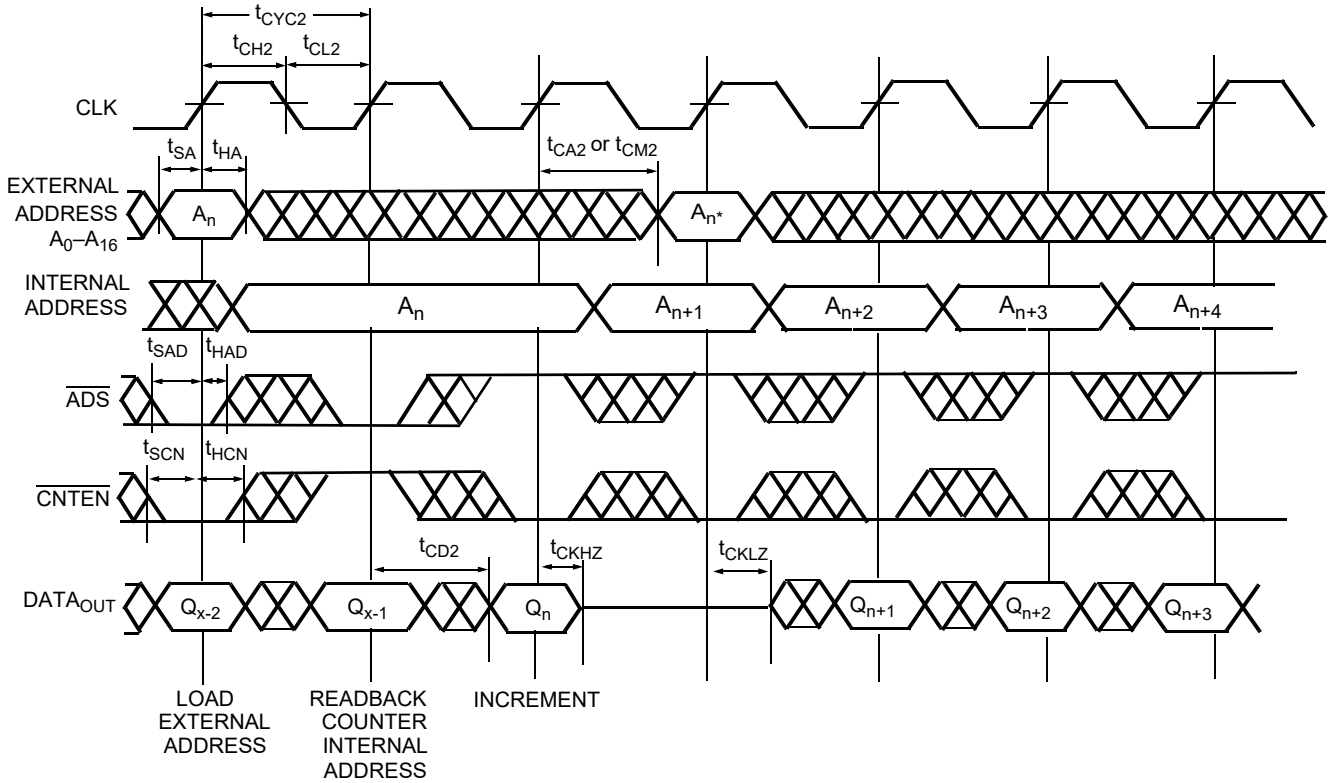

Notes

51. $\overline{CE}_0 = \overline{OE} = \overline{B0-B3} = \text{LOW}$; $CE_1 = R/\overline{W} = \overline{CNTRST} = \overline{MRST} = \text{HIGH}$.
52. Address in output mode. Host must not be driving address bus after t_{CKLZ} in next clock cycle.
53. Address in input mode. Host can drive address bus after t_{CKHZ} .
54. A_n * is the internal value of the address counter (or the mask register depending on the CNT/ \overline{MSK} level) being Read out on the address lines.

Switching Waveforms (continued)

Figure 20. Left_Port (L_Port) Write to Right_Port (R_Port) Read [55, 56, 57]

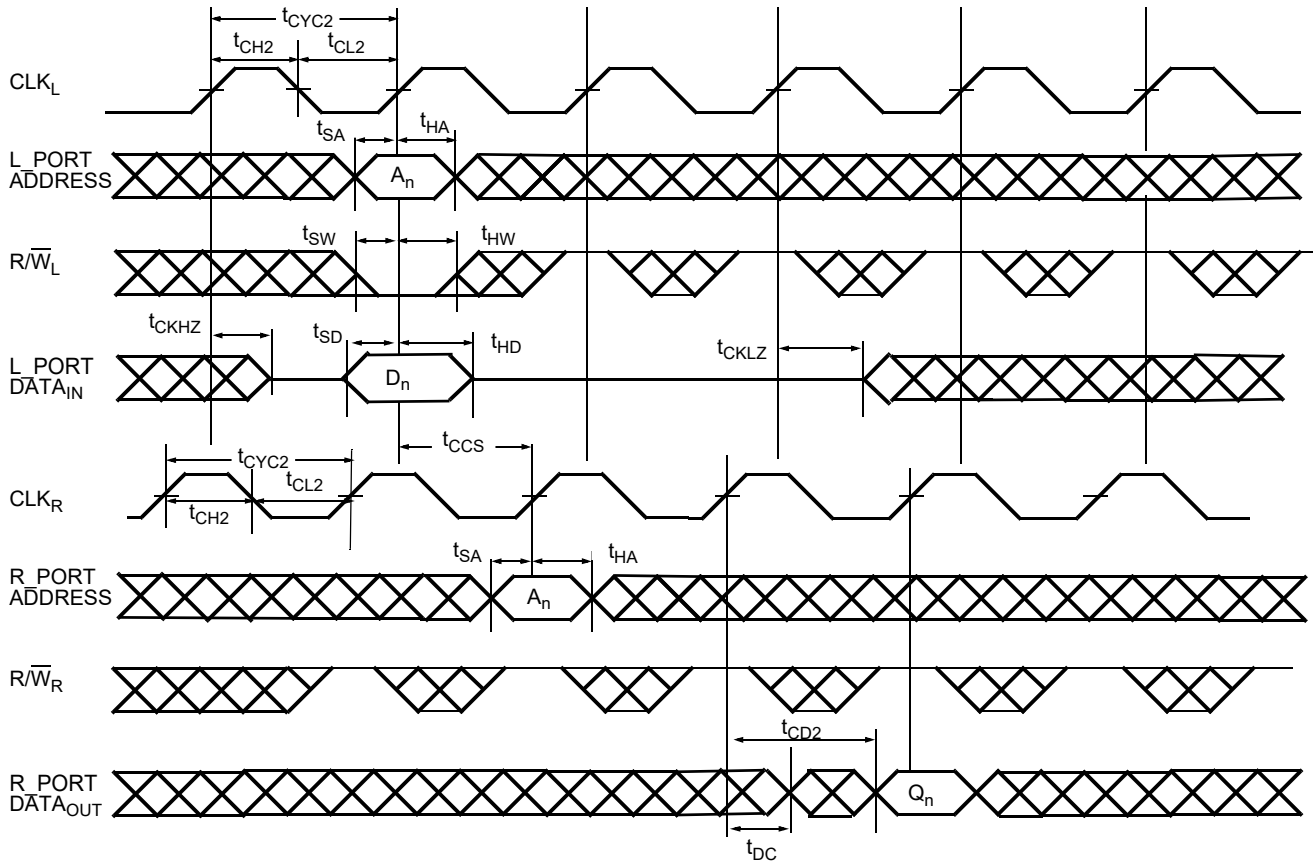

Notes

55. $\overline{CE}_0 = \overline{OE} = \overline{ADS} = \overline{CNTEN} = \overline{B0-B3} = \text{LOW}$; $\overline{CE}_1 = \overline{CNTRST} = \overline{MRST} = \overline{CNT/MSK} = \text{HIGH}$.

56. This timing is valid when one port is writing, and other port is reading the same location at the same time. If t_{CCS} is violated, indeterminate data is Read out.

57. If $t_{CCS} <$ minimum specified value, then R_Port is Read the most recent data (written by L_Port) only ($2 \times t_{CYC2} + t_{CD2}$) after the rising edge of R_Port's clock.

If $t_{CCS} \geq$ minimum specified value, then R_Port is Read the most recent data (written by L_Port) ($t_{CYC2} + t_{CD2}$) after the rising edge of R_Port's clock.

Switching Waveforms (continued)

Figure 21. Counter Interrupt and Retransmit [58, 59, 60, 61, 62]

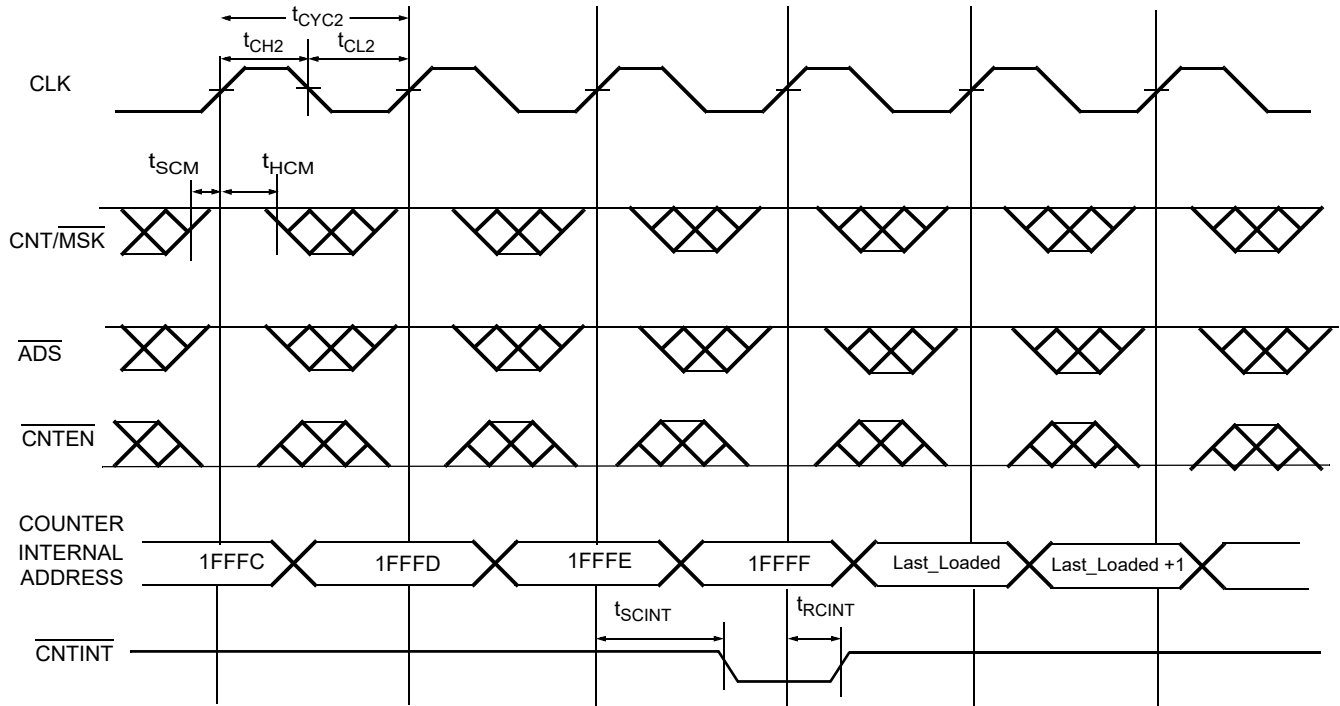

Notes

- 58. Retransmit happens if the counter remains in increment mode after it wraps to initially loaded value
- 59. $\overline{CE}_0 = \overline{OE} = \overline{B}_0 - \overline{B}_3 = \text{LOW}$; $CE_1 = R/\overline{W} = \overline{CNTRST} = \overline{MRST} = \text{HIGH}$.
- 60. \overline{CNTINT} is always driven.
- 61. \overline{CNTINT} goes LOW when the unmasked portion of the address counter is incremented to the maximum value.
- 62. The mask register assumed to have the value of 1FFFFh.

Switching Waveforms (continued)

Figure 22. MailBox Interrupt Timing [63, 64, 65, 66, 67]

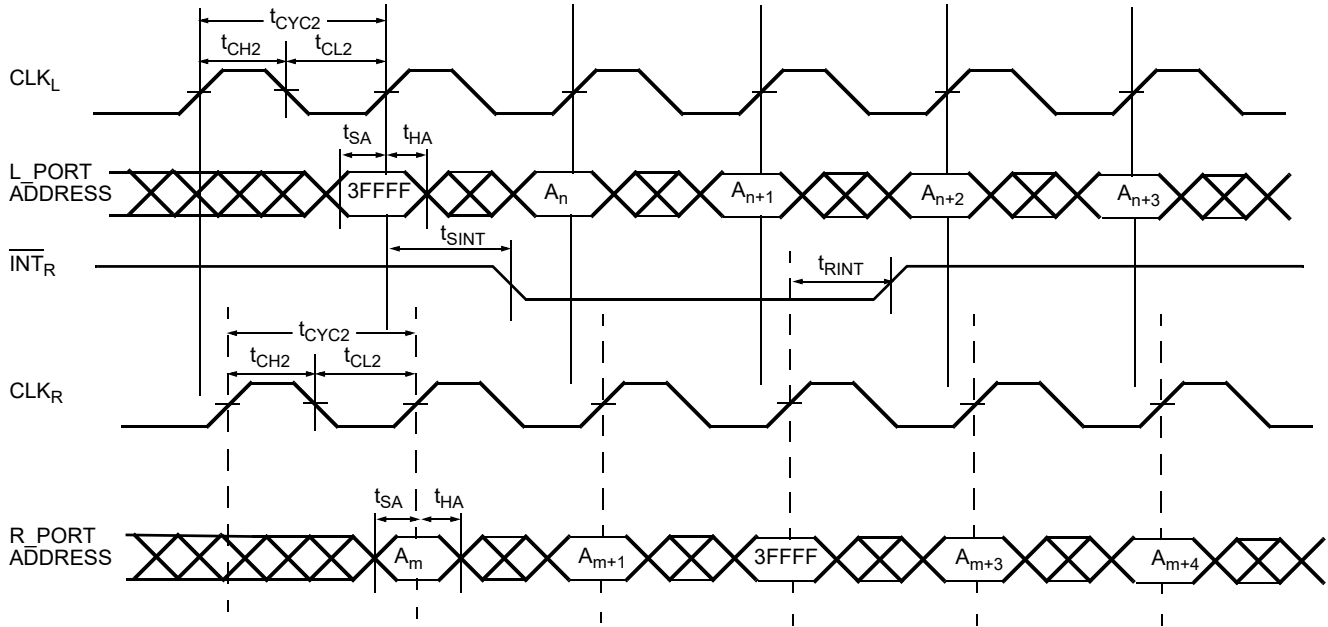

Notes

- 63. $\overline{CE_0} = \overline{OE} = \overline{ADS} = \overline{CNTEN} = \text{LOW}$; $\overline{CE_1} = \overline{CNTRST} = \overline{MRST} = \overline{CNT/MSK} = \text{HIGH}$.
- 64. Address "3FFFF" is the mailbox location for R_Port of a 9M device.
- 65. L_Port is configured for Write operation, and R_Port is configured for Read operation.
- 66. At least one byte enable (B0–B3) is required to be active during interrupt operations.
- 67. Interrupt flag is set with respect to the rising edge of the Write clock, and is reset with respect to the rising edge of the Read clock.

JTAG Timing

Parameter	Description	167/133/100		Unit
		Min	Max	
f_{JTAG}	Maximum JTAG TAP controller frequency	–	10	MHz
t_{TCYC}	TCK clock cycle time	100	–	ns
t_{TH}	TCK clock HIGH time	40	–	ns
t_{TL}	TCK clock LOW Time	40	–	ns
t_{TMSS}	TMS setup to TCK clock rise	10	–	ns
t_{TMSH}	TMS hold after TCK clock rise	10	–	ns
t_{TDIS}	TDI setup to TCK clock rise	10	–	ns
t_{TDIH}	TDI hold after TCK clock rise	10	–	ns
t_{TDOV}	TCK clock LOW to TDO valid	–	30	ns
t_{TDOX}	TCK clock LOW to TDO invalid	0	–	ns

Figure 23. JTAG Switching Waveform

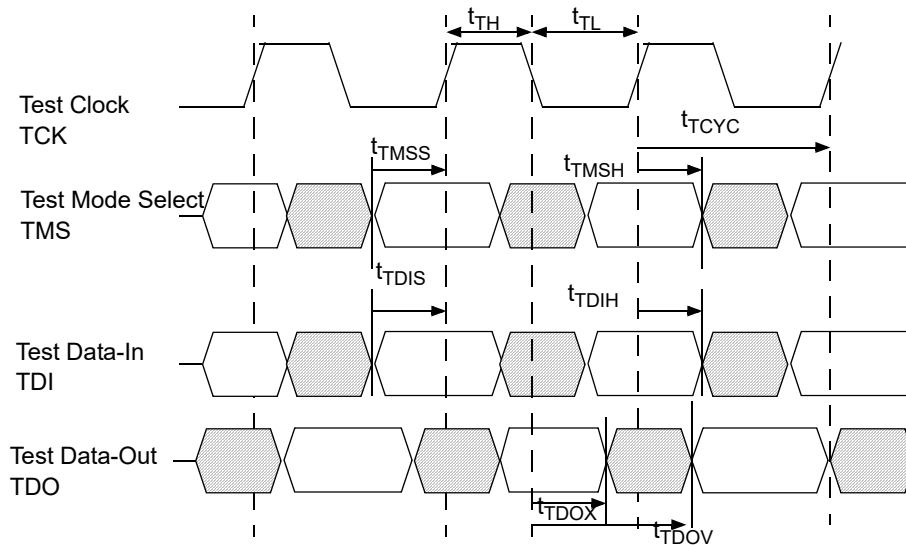

Ordering Information

Cypress offers other versions of this type of product in many different configurations and features. The following table contains only the list of parts that are currently available. For a complete listing of all options, visit the Cypress website at <http://www.cypress.com> and refer to the product summary page at <http://www.cypress.com/products> or contact your local sales representative.

Cypress maintains a worldwide network of offices, solution centers, manufacturer's representatives and distributors. To find the office closest to you, visit us at <http://www.cypress.com/go/datasheet/offices>.

256K × 36 (9M) 3.3 V Synchronous CY7C0853V/CY7C0853AV Dual-Port SRAM

Speed (MHz)	Ordering Code	Package Diagram	Package Type	Operating Range
133	CY7C0853V-133BBI	51-85146	172-ball BGA (15 × 15 × 1.6 mm) with 1 mm pitch	Industrial

Ordering Code Definitions

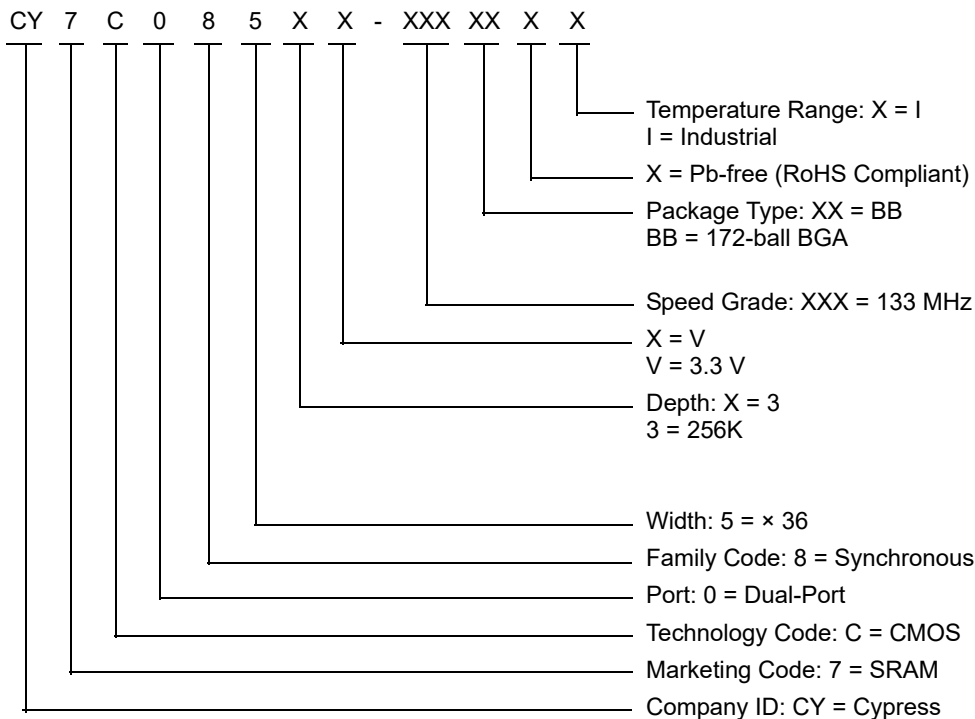

Package Diagrams

Figure 24. 172-ball FBGA ((15 × 15 × 1.6 mm) For Single or Stacked Die) Package Outline, 51-85146

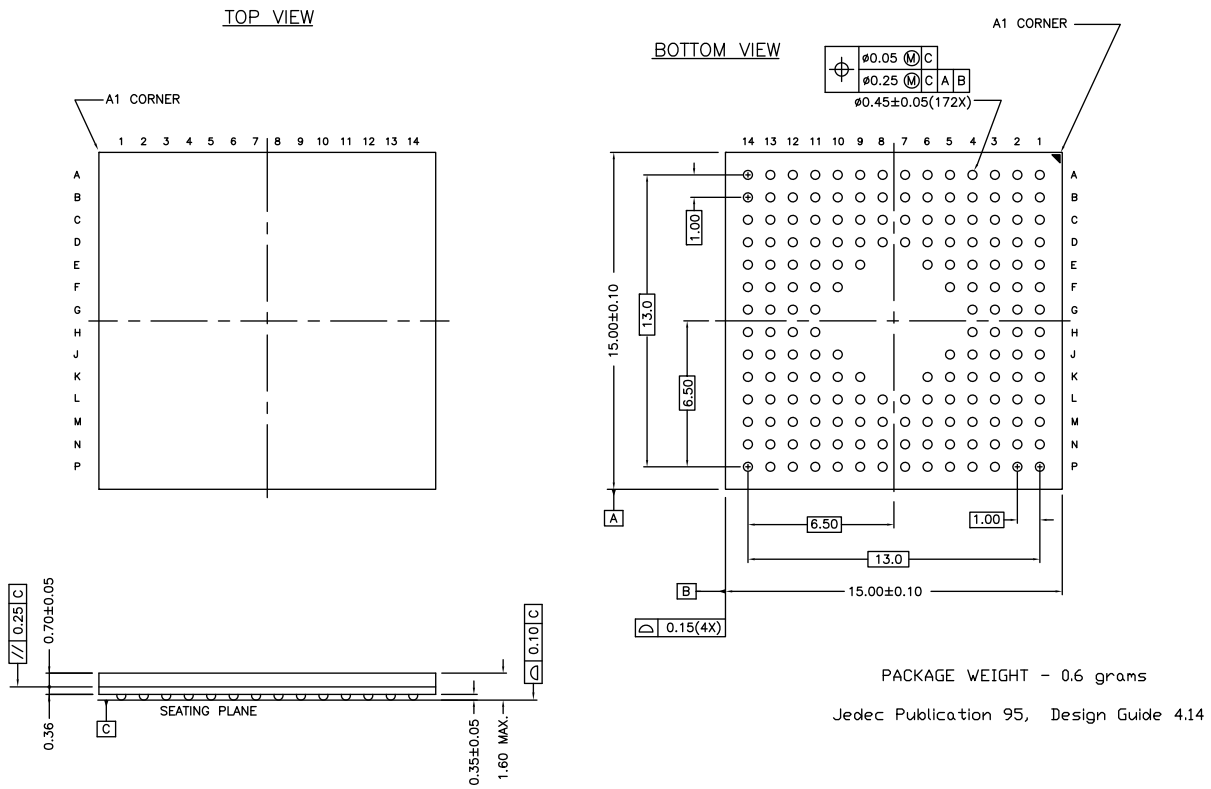

51-85146 *E

Package Diagrams (continued)

Figure 26. 176-pin TQFP (24 × 24 × 1.4 mm) Package Outline, 51-85132

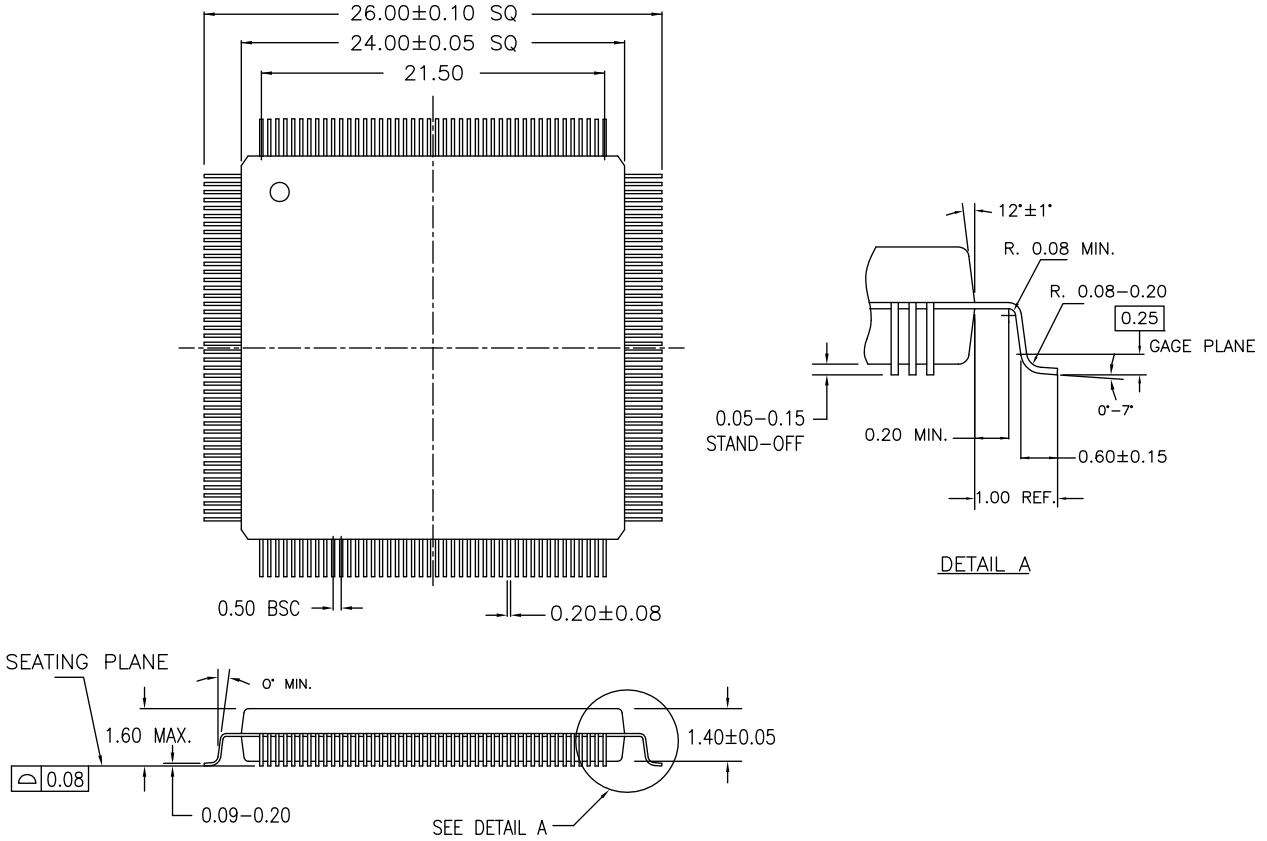

51-85132 *D

Acronyms

Acronym	Description
CMOS	Complementary Metal Oxide Semiconductor
FBGA	Fine-Pitch Ball Grid Array
I/O	Input/Output
JTAG	Joint Test Action Group
SRAM	Static Random Access Memory
TCK	Test Clock Input
TDI	Test Data Input
TDO	Test Data Output
TQFP	Thin Quad Flat Pack

Document Conventions

Units of Measure

Symbol	Unit of Measure
°C	degree Celsius
MHz	megahertz
μA	microampere
mA	milliampere
mV	millivolt
ns	nanosecond
Ω	ohm
pF	picofarad
V	volt
W	watt

Document History Page

Document Title: CY7C0851V/CY7C0851AV/CY7C0852V/CY7C0852AV/CY7C0853V/CY7C0853AV, FLEX36™ 3.3 V, 32K/64K/128K/256K × 36 Synchronous Dual-Port RAM Document Number: 38-06070				
Rev.	ECN No.	Orig. of Change	Submission Date	Description of Change
**	127809	SPN	08/04/2003	This data sheet has been extracted from another data sheet (2M/4M/9M data sheet). The following changes have been made from the original as pertains to this device: Separated out from the 4M data sheet. Updated Product Selection Guide : Updated I _{CC} (values). Updated Pin Configurations : Updated Figure 2 (Corrected 0853 pins L3 and L12). Updated IEEE 1149.1 Serial Boundary Scan (JTAG) : Added discussion of Pause/Restart for JTAG boundary scan. Updated Maximum Ratings : Added Note 23 and referred the same note in "maximum ratings". Updated details corresponding to "Static Discharge Voltage". Updated Electrical Characteristics : Updated values corresponding to I _{CC} parameter. Updated Capacitance (Updated all values). Updated Switching Characteristics : Updated maximum value of t _{CD2} , t _{OE} , t _{OHZ} , t _{CKHZ} , t _{CKLZ} parameters for the CY7C0853V to 4.7 ns. Updated minimum value of t _{HA} , t _{HB} , t _{HD} parameters for -100 speed bin. Updated Switching Waveforms : Updated Figure 11 . Updated Ordering Information (Updated part numbers).
*A	210948	YDT	03/15/2004	Replaced "1FFFE" with "3FFFE" in all instances across the document. Replaced "1FFFF" with "3FFFF" in all instances across the document. Updated Logic Block Diagram (Added Note "Open drain outputs; pull-up resistor required." and referred the same note in INT _L and INT _R at the bottom).
*B	216190	YDT / DCON	04/05/2004	Updated Logic Block Diagram (Removed Note "Open drain outputs; pull-up resistor required." and referred the same note in INT _L and INT _R at the bottom).
*C	231996	YDT	06/07/2004	Updated Functional Description (Updated description).
*D	238938	WWZ	06/30/2004	Updated Document Title to read as "CY7C0850V/CY7C0851V/CY7C0852V/CY7C0853V FLEX36™ 3.3V 32K/64K/128K/256K x 36 Synchronous Dual-Port RAM". Added CY7C0850V, CY7C0851V, CY7C0852V parts related information in all instances across the document. Updated Functional Description : Updated description. Updated Product Selection Guide (Updated almost entire table). Updated Functional Overview : Added Address Counter and Mask Register Operations . Updated Scan Registers Sizes (Added Note 22 and referred the same note in the Bit Size 'n' of Boundary Scan). Updated JTAG Timing (Added 167 MHz frequency range related information). Updated Package Diagrams : Added spec 51-85132 **.
*E	329122	SPN	03/07/2005	Updated Ordering Information (Updated part numbers).

Document History Page (continued)

Document Title: CY7C0851V/CY7C0851AV/CY7C0852V/CY7C0852AV/CY7C0853V/CY7C0853AV, FLEx36™ 3.3 V, 32K/64K/128K/256K × 36 Synchronous Dual-Port RAM Document Number: 38-06070				
Rev.	ECN No.	Orig. of Change	Submission Date	Description of Change
*F	389877	KGH	08/01/2005	Updated Electrical Characteristics : Added I _{SB5} parameter and its details. Updated Switching Characteristics : Changed maximum value of t _{RSF} parameter from existing value to 10 ns for all speed bins. Changed maximum value of t _{RSCNTINT} parameter from existing value to 10 ns for CY7C0850AV/CY7C0851AV/CY7C0852AV. Updated Switching Waveforms : Updated Figure 10 . Updated Figure 11 . Added Figure 14 . Added Figure 15 . Added Figure 16 . Added Figure 17 .
*G	391597	SPN	08/15/2005	Updated Functional Overview : Updated Address Counter and Mask Register Operations : Updated Counter Reset Operation (Updated description (to reflect mirror register behavior)).
*H	2544945	VKN / AESA	07/29/2008	Updated Ordering Information (Updated part numbers). Updated to new template.
*I	2897087	RAME	03/22/2010	Updated Ordering Information (Updated part numbers). Updated Package Diagrams : spec 51-85114 – Changed revision from *B to *C. spec 51-85132 – Changed revision from ** to *A.
*J	3093275	ADMU	11/23/2010	Added CY7C0851V/CY7C0852V/CY7C0853V parts related information in all instances across the document. Added Contents . Updated Ordering Information : Updated part numbers. Added Ordering Code Definitions . Added Acronyms and Units of Measure . Updated to new template. Completing Sunset Review.
*K	3402163	ADMU	10/12/2011	Updated Ordering Information (Updated part numbers). Updated Package Diagrams : spec 51-85114 – Changed revision from *C to *D. Completing Sunset Review.
*L	3698945	SMCH	08/07/2012	Updated Document Title to read as “CY7C0851V/CY7C0851AV/CY7C0852V/ CY7C0852AV/CY7C0853V/CY7C0853AV, FLEx36™ 3.3 V, 32K/64K/128K/256K × 36 Synchronous Dual-Port RAM”. Updated Features (Removed CY7C0850AV related information). Updated Functional Description (Removed CY7C0850AV related information). Updated Product Selection Guide (Removed CY7C0850AV related information). Updated Pin Configurations (Removed CY7C0850AV related information). Updated Pin Definitions (Removed CY7C0850AV related information). Updated Mailbox Interrupts (Removed CY7C0850AV related information). Updated Address Counter and Mask Register Operations (Removed CY7C0850AV related information). Updated IEEE 1149.1 Serial Boundary Scan (JTAG) (Removed CY7C0850AV related information). Updated Identification Register Definitions (Removed CY7C0850AV related information).

Document History Page (continued)

Document Title: CY7C0851V/CY7C0851AV/CY7C0852V/CY7C0852AV/CY7C0853V/CY7C0853AV, FLEx36™ 3.3 V, 32K/64K/128K/256K × 36 Synchronous Dual-Port RAM Document Number: 38-06070				
Rev.	ECN No.	Orig. of Change	Submission Date	Description of Change
*L (cont.)	3698945	SMCH	08/07/2012	Updated Electrical Characteristics (Removed CY7C0850AV related information). Updated Capacitance (Removed CY7C0850AV related information). Updated Switching Characteristics (Removed CY7C0850AV related information). Updated Package Diagrams : Added spec 51-85146 Rev. *D. spec 51-85132 – Changed revision from *A to *B.
*M	3829988	SMCH	12/04/2012	Updated Logic Block Diagram (for better clarity). Updated Functional Overview : Updated Mailbox Interrupts : Updated Note 9 referred in Table 1 . Updated Address Counter and Mask Register Operations : Updated Figure 4 . Updated Switching Waveforms : Updated Note 32 referred in Figure 8 . Updated Package Diagrams : spec 51-85114 – Changed revision from *D to *E. Completing Sunset Review.
*N	4581625	SMCH	11/27/2014	Updated Functional Description : Added “For a complete list of related documentation, click here. ” at the end. Updated Ordering Information : Updated part numbers.
*O	5018928	NILE	11/18/2015	Updated Package Diagrams : spec 51-85146 – Changed revision from *D to *E. spec 51-85132 – Changed revision from *B to *C. Updated to new template. Completing Sunset Review.
*P	6045246	NILE	01/25/2018	Updated Ordering Information : Updated part numbers. Updated Package Diagrams : spec 51-85132 – Changed revision from *C to *D. Updated to new template.
*Q	5942383	NILE	11/13/2018	Updated to new template. Completing Sunset Review.
*R	6542436	NILE	04/12/2019	Updated Ordering Information : Updated part numbers. Updated to new template.

Sales, Solutions, and Legal Information

Worldwide Sales and Design Support

Cypress maintains a worldwide network of offices, solution centers, manufacturer's representatives, and distributors. To find the office closest to you, visit us at [Cypress Locations](#).

Products

Arm [®] Cortex [®] Microcontrollers	cypress.com/arm
Automotive	cypress.com/automotive
Clocks & Buffers	cypress.com/clocks
Interface	cypress.com/interface
Internet of Things	cypress.com/iot
Memory	cypress.com/memory
Microcontrollers	cypress.com/mcu
PSoC	cypress.com/psoc
Power Management ICs	cypress.com/pmic
Touch Sensing	cypress.com/touch
USB Controllers	cypress.com/usb
Wireless Connectivity	cypress.com/wireless

PSoC[®] Solutions

[PSoC 1](#) | [PSoC 3](#) | [PSoC 4](#) | [PSoC 5LP](#) | [PSoC 6 MCU](#)

Cypress Developer Community

[Community](#) | [Projects](#) | [Video](#) | [Blogs](#) | [Training](#) | [Components](#)

Technical Support

cypress.com/support

© Cypress Semiconductor Corporation, 2003–2019. This document is the property of Cypress Semiconductor Corporation and its subsidiaries ("Cypress"). This document, including any software or firmware included or referenced in this document ("Software"), is owned by Cypress under the intellectual property laws and treaties of the United States and other countries worldwide. Cypress reserves all rights under such laws and treaties and does not, except as specifically stated in this paragraph, grant any license under its patents, copyrights, trademarks, or other intellectual property rights. If the Software is not accompanied by a license agreement and you do not otherwise have a written agreement with Cypress governing the use of the Software, then Cypress hereby grants you a personal, non-exclusive, nontransferable license (without the right to sublicense) (1) under its copyright rights in the Software (a) for Software provided in source code form, to modify and reproduce the Software solely for use with Cypress hardware products, only internally within your organization, and (b) to distribute the Software in binary code form externally to end users (either directly or indirectly through resellers and distributors), solely for use on Cypress hardware product units, and (2) under those claims of Cypress's patents that are infringed by the Software (as provided by Cypress, unmodified) to make, use, distribute, and import the Software solely for use with Cypress hardware products. Any other use, reproduction, modification, translation, or compilation of the Software is prohibited.

TO THE EXTENT PERMITTED BY APPLICABLE LAW, CYPRESS MAKES NO WARRANTY OF ANY KIND, EXPRESS OR IMPLIED, WITH REGARD TO THIS DOCUMENT OR ANY SOFTWARE OR ACCOMPANYING HARDWARE, INCLUDING, BUT NOT LIMITED TO, THE IMPLIED WARRANTIES OF MERCHANTABILITY AND FITNESS FOR A PARTICULAR PURPOSE. No computing device can be absolutely secure. Therefore, despite security measures implemented in Cypress hardware or software products, Cypress shall have no liability arising out of any security breach, such as unauthorized access to or use of a Cypress product. CYPRESS DOES NOT REPRESENT, WARRANT, OR GUARANTEE THAT CYPRESS PRODUCTS, OR SYSTEMS CREATED USING CYPRESS PRODUCTS, WILL BE FREE FROM CORRUPTION, ATTACK, VIRUSES, INTERFERENCE, HACKING, DATA LOSS OR THEFT, OR OTHER SECURITY INTRUSION (collectively, "Security Breach"). Cypress disclaims any liability relating to any Security Breach, and you shall and hereby do release Cypress from any claim, damage, or other liability arising from any Security Breach. In addition, the products described in these materials may contain design defects or errors known as errata which may cause the product to deviate from published specifications. To the extent permitted by applicable law, Cypress reserves the right to make changes to this document without further notice. Cypress does not assume any liability arising out of the application or use of any product or circuit described in this document. Any information provided in this document, including any sample design information or programming code, is provided only for reference purposes. It is the responsibility of the user of this document to properly design, program, and test the functionality and safety of any application made of this information and any resulting product. "High-Risk Device" means any device or system whose failure could cause personal injury, death, or property damage. Examples of High-Risk Devices are weapons, nuclear installations, surgical implants, and other medical devices. "Critical Component" means any component of a High-Risk Device whose failure to perform can be reasonably expected to cause, directly or indirectly, the failure of the High-Risk Device, or to affect its safety or effectiveness. Cypress is not liable, in whole or in part, and you shall and hereby do release Cypress from any claim, damage, or other liability arising from any use of a Cypress product as a Critical Component in a High-Risk Device. You shall indemnify and hold Cypress, its directors, officers, employees, agents, affiliates, distributors, and assigns harmless from and against all claims, costs, damages, and expenses, arising out of any claim, including claims for product liability, personal injury or death, or property damage arising from any use of a Cypress product as a Critical Component in a High-Risk Device. Cypress products are not intended or authorized for use as a Critical Component in any High-Risk Device except to the limited extent that (i) Cypress's published data sheet for the product explicitly states Cypress has qualified the product for use in a specific High-Risk Device, or (ii) Cypress has given you advance written authorization to use the product as a Critical Component in the specific High-Risk Device and you have signed a separate indemnification agreement.

Cypress, the Cypress logo, Spansion, the Spansion logo, and combinations thereof, WICED, PSoC, CapSense, EZ-USB, F-RAM, and Traveo are trademarks or registered trademarks of Cypress in the United States and other countries. For a more complete list of Cypress trademarks, visit cypress.com. Other names and brands may be claimed as property of their respective owners.

Looking for pricing, stock, or lifecycle information?

Click below to explore more details on WIN SOURCE:

 [View CY7C0853V-133BBC on WIN SOURCE](#)

 [Cypress Semiconductor Corp](#) Information

Optimize Your Supply Chain with WIN SOURCE Solutions

-  Global Sourcing Solution
-  Obsolete Management
-  Cost Control Management
-  Shortage Management
-  Alternative Solution
-  Excess Inventory Management