



**THE DATASHEET OF
TPS650244IRHBRQ1**



POWER MANAGEMENT ICs FOR LI-ION POWERED SYSTEMS

 Check for Samples: [TPS650241-Q1](#), [TPS650243-Q1](#), [TPS650244-Q1](#)

FEATURES

- Qualified for Automotive Applications
- 1.6-A, 1.0-A or 0.8-A, 97% Efficient Step-Down Converter for System Voltage (VDCDC1)
 - 3.3-V or 2.80-V or Adjustable
- 1.6-A, 1.0-A or 0.8-A, up to 95% Efficient Step-Down Converter for Memory Voltage (VDCDC2)
 - 1.8 V or 2.5 V or Adjustable
- 0.8-A 90% Efficient Step-Down Converter for Processor Core (VDCDC3)
- Three Selectable Voltages for VDCDC3
 - **TPS650241**
 - DEFDCDC3 = LOW: $V_O = 0.9\text{ V}$
 - DEFDCDC3 = HIGH: $V_O = 1.375\text{ V}$
 - **TPS650243**
 - DEFDCDC3 = LOW: $V_O = 1.0\text{ V}$
 - DEFDCDC3 = HIGH: $V_O = 1.2\text{ V}$
 - **TPS650244**
 - DEFDCDC3 = LOW: $V_O = 1.55\text{ V}$
 - DEFDCDC3 = HIGH: $V_O = 1.6\text{ V}$
- 30-mA LDO for Vdd_alive
- Two 200-mA General Purpose LDOs (LDO1 and LDO2)
- Dynamic Voltage Management for Processor Core
- LDO1 and LDO2 Voltage Externally Adjustable
- Separate Enable Pins for Inductive Converters
- 2.25-MHz Switching Frequency
- 85- μA Quiescent Current
- Thermal Shutdown Protection

APPLICATIONS

- PDA
- Cellular/Smart Phone
- GPS
- Digital Still Camera
- Split Supply DSP and Microprocessor Solutions: Samsung ARM-Based Processors, etc.

DESCRIPTION

The TPS65024x are integrated Power Management ICs for applications powered by one Li-Ion or Li-Polymer cell, which require multiple power rails. The TPS65024x provide three highly efficient, step-down converters targeted at providing the core voltage, peripheral, I/O and memory rails in a processor based system. All three step-down converters enter a low power mode at light load for maximum efficiency across the widest possible range of load currents. The converters can be forced into fixed frequency PWM mode by pulling the MODE pin high. The TPS65024x also integrate two general purpose 200-mA LDO voltage regulators, which are enabled with an external input pin. Each LDO operates with an input voltage range between 1.5 V and 6.5 V, allowing them to be supplied from one of the step-down converters or directly from the battery. The output voltage of the LDOs can be set with an external resistor divider for maximum flexibility. Additionally there is a 30-mA LDO typically used to provide power in a processor based system to a voltage rail that is always on. TPS65024x provide voltage scaling on DCDC3 using the DEFDCDC3 pin. This pin either needs to be connected to a logic HIGH or logic LOW level to set the output voltage of DCDC3. TPS65024x come in a small 5-mm x 5-mm 32-pin QFN package (RHB).

ORDERING INFORMATION⁽¹⁾

T_A	PACKAGE ⁽²⁾		ORDERABLE PART NUMBER	TOP-SIDE MARKING
–40°C to 125°C	QFN – RHB	Reel of 3000	TPS650241QRHBRQ1	TPS650241Q
			TPS650243QRHBRQ1	TPS650243Q
TPS650244IRHBRQ1			TPS650244Q	
–40°C to 85°C				

(1) For the most current package and ordering information, see the Package Option Addendum at the end of this document, or see the TI web site at www.ti.com.

(2) Package drawings, thermal data, and symbolization are available at www.ti.com/packaging.



Please be aware that an important notice concerning availability, standard warranty, and use in critical applications of Texas Instruments semiconductor products and disclaimers thereto appears at the end of this data sheet.



This integrated circuit can be damaged by ESD. Texas Instruments recommends that all integrated circuits be handled with appropriate precautions. Failure to observe proper handling and installation procedures can cause damage.

ESD damage can range from subtle performance degradation to complete device failure. Precision integrated circuits may be more susceptible to damage because very small parametric changes could cause the device not to meet its published specifications.

ABSOLUTE MAXIMUM RATINGS

over operating free-air temperature range (unless otherwise noted) ⁽¹⁾

	VALUE	UNIT
Input voltage range on all pins except A/PGND, VLDO1 and VLDO2 pins with respect to AGND	–0.3 to 7	V
Voltage range on pins VLDO1 and VLDO2 with respect to AGND	–0.3 to 3.6	V
Current at VINDCDC1, L1, PGND1, VINDCDC2, L2, PGND2, VINDCDC3, L3, PGND3	2000	mA
Peak current at all other pins	1000	mA
Continuous total power dissipation	See Dissipation Rating Table	
T _J Operating junction temperature	–40 to 125	°C
T _{st} Storage temperature	–65 to 150	°C
Lead temperature 1,6 mm (1/16-inch) from case for 10 seconds	260	°C

(1) Stresses beyond those listed under *absolute maximum ratings* may cause permanent damage to the device. These are stress ratings only and functional operation of the device at these or any other conditions beyond those indicated under *recommended operating conditions* is not implied. Exposure to absolute-maximum-rated conditions for extended periods may affect device reliability.

DISSIPATION RATINGS

PACKAGE ⁽¹⁾	R _{θJA}	T _J ≤ 25°C POWER RATING	DERATING FACTOR ABOVE T _J = 25°C	T _J = 70°C POWER RATING	T _J = 85°C POWER RATING
RHB	35°C/W	2.85 W	28 mW/°C	1.57 W	1.14 W

(1) The thermal resistance junction to ambient of the RHB package is measured on a high K board. The thermal resistance junction to power pad is 1.5°C/W.

RECOMMENDED OPERATING CONDITIONS

		MI N	NOM	MAX	UNIT	
V_{INDCDC1} , V_{INDCDC2} , V_{INDCDC3} , V_{CC}	Input voltage range step-down converters	2.5		6.0	V	
V_{DCDC1}	Output voltage range for VDCDC1 step-down converter ⁽¹⁾	0.6		V_{INDCDC1}	V	
V_{DCDC2}	Output voltage range for mem step-down converter ⁽¹⁾	0.6		V_{INDCDC2}	V	
V_{DCDC3}	Output voltage range for core step-down converter	0.9		1.5	V	
V_{INLDO1} , V_{INLDO2}	Input voltage range for LDOs	1.5		6.5	V	
$V_{\text{LDO1-2}}$	Output voltage range for LDOs	1.0		3.3	V	
I_{OUTDCDC1}	Output current at L1			1600	mA	
L1	Inductor at L1 ⁽²⁾	1.5	2.2		μH	
C_{INDCDC1}	Input capacitor at V_{INDCDC1} ⁽²⁾	10			μF	
C_{OUTDCDC1}	Output capacitor at V_{DCDC1} ⁽²⁾	10	22		μF	
I_{OUTDCDC2}	Output current at L2			1600	mA	
L2	Inductor at L2 ⁽²⁾	1.5	2.2		μH	
C_{INDCDC2}	Input capacitor at V_{INDCDC2} ⁽²⁾	10			μF	
C_{OUTDCDC2}	Output capacitor at V_{DCDC2} ⁽²⁾	10	22		μF	
I_{OUTDCDC3}	Output current at L3			800	mA	
L3	Inductor at L3 ⁽²⁾	1.5	2.2		μH	
C_{INDCDC3}	Input capacitor at V_{INDCDC3} ⁽²⁾	10			μF	
C_{OUTDCDC3}	Output capacitor at V_{DCDC3} ⁽²⁾	10	22		μF	
C_{VCC}	Input capacitor at VCC ⁽²⁾	1			μF	
$C_{\text{in1-2}}$	Input capacitor at VINLDO ⁽²⁾	1			μF	
$C_{\text{OUT1-2}}$	Output capacitor at VLDO1, VLDO2 ⁽²⁾	2.2			μF	
$I_{\text{LDO1,2}}$	Output current at VLDO1, VLDO2			200	mA	
C_{VRTC}	Output capacitor at Vdd_alive ⁽²⁾	2.2			μF	
$I_{\text{Vdd_alive}}$	Output current at Vdd_alive			30	mA	
T_{A}	Operating ambient temperature	TPS65024XQRHBRQ1		-40	125	°C
		TPS650244IRHBRQ1		-40	85	
T_{J}	Operating junction temperature			-40	125	°C
R_{CC}	Resistor from VINDCDC3, VINDCDC2, VINDCDC1 to Vcc used for filtering ⁽³⁾		1	10	Ω	

(1) When using an external resistor divider at DEFDCDC2, DEFDCDC1.

(2) See applications section for more information, for $V_{\text{out}} > 2.85$ V choose 3.3-μH inductor.

(3) Up to 2.5 mA can flow into Vcc when all three converters are running in PWM; this resistor causes the UVLO threshold to be shifted accordingly.

ELECTRICAL CHARACTERISTICS

VINDCDC1 = VINDCDC2 = VINDCDC3 = VCC = VINLDO = 3.6 V, T_J = -40°C to 125°C, typical values are at T_A = 25°C (unless otherwise noted)

CONTROL SIGNALS: EN_DCDC1, EN_DCDC2, EN_DCDC3, EN_LDO, MODE, EN_VDD_ALIVE						
PARAMETER		TEST CONDITIONS	MIN	TYP	MAX	UNIT
V _{IH}	High level input voltage		1.45		VCC	V
V _{IL}	Low level input voltage		0		0.4	V
I _H	Input bias current			0.01	0.1	μA
SUPPLY PINS: VCC, VINDCDC1, VINDCDC2, VINDCDC3						
I _{q(PFM)}	Operating quiescent current	PFM All three dc-dc converters enabled, zero load and no switching, LDOs enabled	V _{CC} = 3.6 V	135	170	μA
		PFM All three dc-dc converters enabled, zero load and no switching, LDO1, LDO2 = OFF, V _{dd_alive} = ON		75	100	
		PFM DCDC1 and DCDC2 converters enabled, zero load and no switching, LDO1, LDO2 = OFF, V _{dd_alive} = ON		55	80	
		PFM DCDC1 converter enabled, zero load and no switching, LDO1, LDO2 = OFF, V _{dd_alive} = ON		40	60	
I _{VCC(PWM)}	Current into V _{CC} , PWM	All three dc-dc converters enabled and running in PWM, LDOs off	V _{CC} = 3.6 V	2		mA
		PWM DCDC1 and DCDC2 converters enabled and running in PWM, LDOs off		1.5	2.5	
		PWM DCDC1 converter enabled and running in PWM, LDOs off		0.85	2.0	
I _q	Quiescent current	All converters disabled, LDO1, LDO2 = OFF, V _{dd_alive} = OFF	V _{CC} = 3.6 V	16		μA
		All converters disabled, LDO1, LDO2 = OFF, V _{dd_alive} = ON		26		

ELECTRICAL CHARACTERISTICS

VINDCDC1 = VINDCDC2 = VINDCDC3 = VCC = VINLDO = 3.6V, T_J = –40°C to 125°C, typical values are at T_A = 25°C (unless otherwise noted)

PARAMETER		TEST CONDITIONS		MIN	TYP	MAX	UNIT
VDCDC1 STEP-DOWN CONVERTER							
V _{VINDCDC1}	Input voltage range			2.5		6.0	V
I _O	Maximum output current for TPS65024X	V _O = 3.3 V		1600			mA
I _O	Maximum output current for TPS650244	V _O = 3.3 V		800			
I _{SD}	Shutdown supply current in VINDCDC1	EN_DCDC1 = GND			0.1	1	μA
R _{DS(ON)}	P-channel MOSFET on-resistance	VINDCDC1 = VGS = 3.6 V			125	261	mΩ
I _{LP}	P-channel leakage current	VINDCDC1 = 6.0 V				2	μA
R _{DS(ON)}	N-channel MOSFET on-resistance	VINDCDC1 = VGS = 3.6 V			130	260	mΩ
I _{LN}	N-channel leakage current	V _{DS} = 6.0 V			7	10	μA
I _{LIMF}	Forward current limit (P- and N-channel) for TPS65024X	2.5V < V _{INMAIN} < 6.0 V		1.7	1.97	2.2	A
I _{LIMF}	Forward current limit (P- and N-channel) for TPS650244	2.5V < V _{INMAIN} < 6.0 V		0.88	1.10	1.28	
f _S	Oscillator frequency			1.95	2.25	2.55	MHz
VDCDC1	Fixed output voltage MODE = 0 (PWM/PFM)	2.80 V	VINDCDC1 = 3.3 V to 6.0 V; 0 mA ≤ I _O ≤ 1.6A	-2%		2%	
		3.3 V		-2%		2%	
	Fixed output voltage MODE = 1 (PWM)	2.80 V	VINDCDC1 = 3.7 V to 6.0 V; 0 mA ≤ I _O ≤ 1.6 A	-1%		1%	
		3.3 V		-1%		1%	
	Adjustable output voltage with resistor divider at DEFDCDC1 MODE = 0 (PWM/PFM)	VINDCDC1 = VDCDC1 + 0.4 V (min 2.5 V) to 6.0 V; 0 mA ≤ I _O ≤ 1.6 A		-2%		2%	
Adjustable output voltage with resistor divider at DEFDCDC1; MODE = 1 (PWM)	VINDCDC1 = VDCDC1 + 0.4 V (min 2.5 V) to 6.0 V; 0 mA ≤ I _O ≤ 1.6 A		-1%		1%		
Line regulation		VINDCDC1 = VDCDC1 + 0.3 V (min 2.5 V) to 6.0 V; I _O = 10 mA			0.0		%/V
Load regulation		I _O = 10 mA to 1.6 A			0.25		%/A
t _{SS}	Soft start ramp time	VDCDC1 ramping from 5% to 95% of target value			750		μs
R(L1)	Internal resistance from L1 to GND				1		MΩ

ELECTRICAL CHARACTERISTICS

VINDCDC1 = VINDCDC2 = VINDCDC3 = VCC = VINLDO = 3.6 V, T_J = -40°C to 125°C, typical values are at T_A = 25°C (unless otherwise noted)

PARAMETER		TEST CONDITIONS		MIN	TYP	MAX	UNIT	
VDCDC2 STEP-DOWN CONVERTER								
V _{VINDCDC2}	Input voltage range			2.5		6.0	V	
I _O	Maximum output current for TPS65024X	V _O = 2.5 V		1000			mA	
I _O	Maximum output current for TPS650244	V _O = 2.5 V		1600				
I _{SD}	Shutdown supply current in VINDCDC2	EN_DCDC2 = GND			0.1	1	μA	
R _{DS(ON)}	P-channel MOSFET on-resistance	VINDCDC2 = V _{GS} = 3.6 V			140	300	mΩ	
I _{LP}	P-channel leakage current	VINDCDC2 = 6.0 V				2	μA	
R _{DS(ON)}	N-channel MOSFET on-resistance	VINDCDC2 = V _{GS} = 3.6 V			150	297	mΩ	
I _{LN}	N-channel leakage current	V _{DS} = 6.0 V			7	10	μA	
I _{LIMF}	Forward current limit (P- and N-channel) for TPS65024X	2.5 V < VINDCDC2 < 6.0 V		1.22	1.35	1.50	A	
I _{LIMF}	Forward current limit (P- and N-channel) for TPS650244	2.5 V < VINDCDC2 < 6.0 V		1.50	1.97	2.35		
f _S	Oscillator frequency			1.95	2.25	2.55	MHz	
VDCDC2	Fixed output voltage MODE = 0 (PWM/PFM)	1.8V	VINDCDC2 = 2.5 V to 6.0 V; 0 mA ≤ I _O ≤ 1.6 A	-2%		2%		
		2.5V	VINDCDC2 = 3.0 V to 6.0 V; 0 mA ≤ I _O ≤ 1.6 A	-2%		2%		
	Fixed output voltage MODE = 1 (PWM)	1.8V	VINDCDC2 = 2.5 V to 6.0 V; 0 mA ≤ I _O ≤ 1.6 A	-2%		2%		
		2.5V	VINDCDC2 = 3.0 V to 6.0 V; 0 mA ≤ I _O ≤ 1.6 A	-1%		1%		
	Adjustable output voltage with resistor divider at DEFDCDC2 MODE = 0 (PWM)		VINDCDC2 = VDCDC2 + 0.5 V (min 2.5 V) to 6.0 V; 0 mA ≤ I _O ≤ 1.6 A		-2%		2%	
	Adjustable output voltage with resistor divider at DEFDCDC2; MODE = 1 (PWM)		VINDCDC2 = VDCDC2 + 0.5 V (min 2.5 V) to 6.0 V; 0 mA ≤ I _O ≤ 1.6 A		-1%		1%	
Line regulation		VINDCDC2 = VDCDC2 + 0.3 V (min 2.5 V) to 6.0 V; I _O = 10 mA			0.0		%/V	
Load regulation		I _O = 10 mA to 1.6 A			0.25		%/A	
t _{SS}	Soft start ramp time	VDCDC2 ramping from 5% to 95% of target value			750		μs	
R(L2)	Internal resistance from L2 to GND				1		MΩ	

ELECTRICAL CHARACTERISTICS

VINDCDC1 = VINDCDC2 = VINDCDC3 = VCC = VINLDO = 3.6 V, T_J = –40°C to 125°C, typical values are at T_A = 25°C (unless otherwise noted)

PARAMETER		TEST CONDITIONS	MIN	TYP	MAX	UNIT
VDCDC3 STEP-DOWN CONVERTER						
V _{VINDCDC3}	Input voltage range		2.5		6.0	V
I _O	Maximum output current	V _O = 1.6 V	800			mA
I _{SD}	Shutdown supply current in VINDCDC3	EN_DCDC3 = GND		0.1	1	μA
R _{DS(ON)}	P-channel MOSFET on-resistance	V _{VINDCDC3} = V _{GS} = 3.6 V		310	698	mΩ
I _{LP}	P-channel leakage current	V _{VINDCDC3} = 6.0V		0.1	2	μA
R _{DS(ON)}	N-channel MOSFET on-resistance	V _{VINDCDC3} = V _{GS} = 3.6 V		220	503	mΩ
I _{LN}	N-channel leakage current	V _{DS} = 6.0 V		7	10	μA
I _{LIMF}	Forward current limit (P- and N-channel)	2.5 V < V _{VINDCDC3} < 6.0 V	1.00	1.20	1.40	A
f _S	Oscillator frequency		1.95	2.25	2.55	MHz
VDCDC3	Fixed output voltage MODE = 0 (PWM/PFM)	V _O = 0.9V to 1.6V V _{VINDCDC3} = 2.5 V to 6.0 V; 0 mA ≤ I _O ≤ 800 mA	–2%		2%	
	Fixed output voltage MODE = 1 (PWM)		–1%		1%	
	Line regulation	V _{VINDCDC3} = VDCDC3 + 0.3 V (min. 2.5 V) to 6.0 V; I _O = 10 mA	0.0		%V	
	Load regulation	I _O = 10 mA to 600 mA	0.25		%A	
t _{SS}	Soft start ramp time	VDCDC3 ramping from 5% to 95% of target value	750		μs	
R(L3)	Internal resistance from L3 to GND		1		MΩ	

ELECTRICAL CHARACTERISTICS

VINDCDC1 = VINDCDC2 = VINDCDC3 = VCC = VINLDO = 3.6 V, $T_J = -40^{\circ}\text{C}$ to 125°C , typical values are at $T_A = 25^{\circ}\text{C}$ (unless otherwise noted)

PARAMETER		TEST CONDITIONS	MIN	TYP	MAX	UNIT
VLDO1 and VLDO2 Low Dropout Regulators						
$I(q)$	Operating quiescent current	Current per LDO into VINLDO		16	30	μA
$I(\text{SD})$	Shutdown current	Total current into VINLDO, VLDO = 0 V		0.6	2	μA
V_{INLDO}	Input voltage range for LDO1, LDO2		1.5		6.5	V
VFB	LDO1 and LDO2 feedback voltage	See ⁽¹⁾		1.0		V
I_O	Maximum output current for LDO1, LDO2	$V_{\text{in}} = 1.8\text{ V}$, $V_O = 1.3\text{ V}$	200			mA
I_O	Maximum output current for LDO1, LDO2	$V_{\text{in}} = 1.5\text{ V}$; $V_O = 1.3\text{ V}$		120		mA
I_{SC}	LDO1 & LDO2 short circuit current limit	$V_{\text{LDO1}} = \text{GND}$, $V_{\text{LDO2}} = \text{GND}$			400	mA
	Minimum voltage drop at LDO1, LDO2	$I_O = 50\text{ mA}$, $V_{\text{INLDO}} = 1.8\text{ V}$			120	mV
	Minimum voltage drop at LDO1, LDO2	$I_O = 50\text{ mA}$, $V_{\text{INLDO}} = 1.5\text{ V}$		65	150	mV
	Minimum voltage drop at LDO1, LDO2	$I_O = 200\text{ mA}$, $V_{\text{INLDO}} = 1.8\text{ V}$			300	mV
	Output voltage accuracy for LDO1, LDO2	$I_O = 10\text{ mA}$	-2%		1%	
	Line regulation for LDO1, LDO2	$V_{\text{INLDO1,2}} = V_{\text{LDO1,2}} + 0.5\text{ V}$ (min 2.5 V) to 6.5 V, $I_O = 10\text{ mA}$	-1%		1%	
	Load regulation for LDO1, LDO2	$I_O = 0\text{ mA}$ to 200 mA	-1%		1%	
	Regulation time for LDO1, LDO2	Load change from 10% to 90%		10		μs
Vdd_alive Low Dropout Regulator						
Vdd_alive	Vdd_alive LDO output voltage	$I_O = 0\text{ mA}$		1.2		V
I_O	Output current for Vdd_alive				30	mA
I_{SC}	Vdd_alive short circuit current limit	Vdd_alive = GND			100	mA
	Output voltage accuracy for Vdd_alive	$I_O = 0\text{ mA}$	-1%		1%	
	Line regulation for Vdd_alive	$V_{\text{CC}} = \text{Vdd_alive} + 0.5\text{ V}$ to 6.5 V, $I_O = 0\text{ mA}$	-1%		1%	
	Regulation time for Vdd_alive	Load change from 10% to 90%		10		μs
AnaLogic Signals DEFDCDC1, DEFDCDC2, DEFDCDC3						
V_{IH}	High level input voltage		1.3		VCC	V
V_{IL}	Low level input voltage		0		0.1	V
I_{H}	Input bias current			0.001	0.05	μA
THERMAL SHUTDOWN						
T_{SD}	Thermal shutdown	Increasing junction temperature		160		$^{\circ}\text{C}$
	Thermal shutdown hysteresis	Decreasing junction temperature		20		$^{\circ}\text{C}$
INTERNAL UNDER VOLTAGE LOCK OUT						
UVLO	Internal UVLO	VCC falling	-3%	2.35	3%	V
$V_{\text{UVLO_HYST}}$	Internal UVLO comparator hysteresis			120		mV
VOLTAGE DETECTOR COMPARATOR						
PWRFAIL_SNS	Comparator threshold	Falling threshold	-2%	1.0	2%	V
	Hysteresis		40	50	60	mV
	Propagation delay	25-mV overdrive			10	μs
V_{OL}	Power fail output low voltage	$I_{\text{OL}} = 5\text{ mA}$			0.3	V

(1) If the feedback voltage is forced higher than 1.2 V, a leakage current into the feedback pin may occur.

TERMINAL FUNCTIONS (continued)

TERMINAL		I/O	DESCRIPTION
NAME	NO.		
DEFDCDC3	32	I	Input signal indicating VDCDC3 voltage. TPS650241: 0 = 0.9 V, 1 = 1.375 V TPS650243: 0 = 1.0 V, 1 = 1.2 V TPS650244: 0 = 1.55 V, 1 = 1.6 V
EN_DCDC1	20	I	VDCDC1 enable pin. A logic high enables the regulator, a logic low disables the regulator.
EN_DCDC2	19	I	VDCDC2 enable pin. A logic high enables the regulator, a logic low disables the regulator.
EN_DCDC3	18	I	VDCDC3 enable pin. A logic high enables the regulator, a logic low disables the regulator.
LDO REGULATOR SECTION			
VINLDO	15	I	Input voltage for LDO1 and LDO2
VLDO1	16	O	Output voltage of LDO1
VLDO2	14	O	Output voltage of LDO2
EN_LDO	17	I	Enable input for LDO1 and LDO2. Logic high enables the LDOs, logic low disables the LDOs
EN_Vdd_alive	24	I	Enable input for Vdd_alive LDO. Logic high enables the LDO, logic low disables the LDO
Vdd_alive	12	O	Output voltage for Vdd_alive
FB_LDO1	11	I	Feedback pin for LDO1
FB_LDO2	10	I	Feedback pin for LDO2
CONTROL AND I2C SECTION			
MODE	23	I	Select between Power Safe Mode and forced PWM Mode for DCDC1, DCDC2 and DCDC3. In Power Safe Mode PFM is used at light loads, PWM for higher loads. If PIN is set to high level, forced PWM Mode is selected. If Pin has low level, then Device operates in Power Safe Mode.
PWRFAIL	21	O	Open drain output. Active low when PWRFAIL comparator indicates low VBAT condition.
PWRFAIL_SNS	30	I	Input for the comparator driving the /PWRFAIL output

FUNCTIONAL BLOCK DIAGRAM

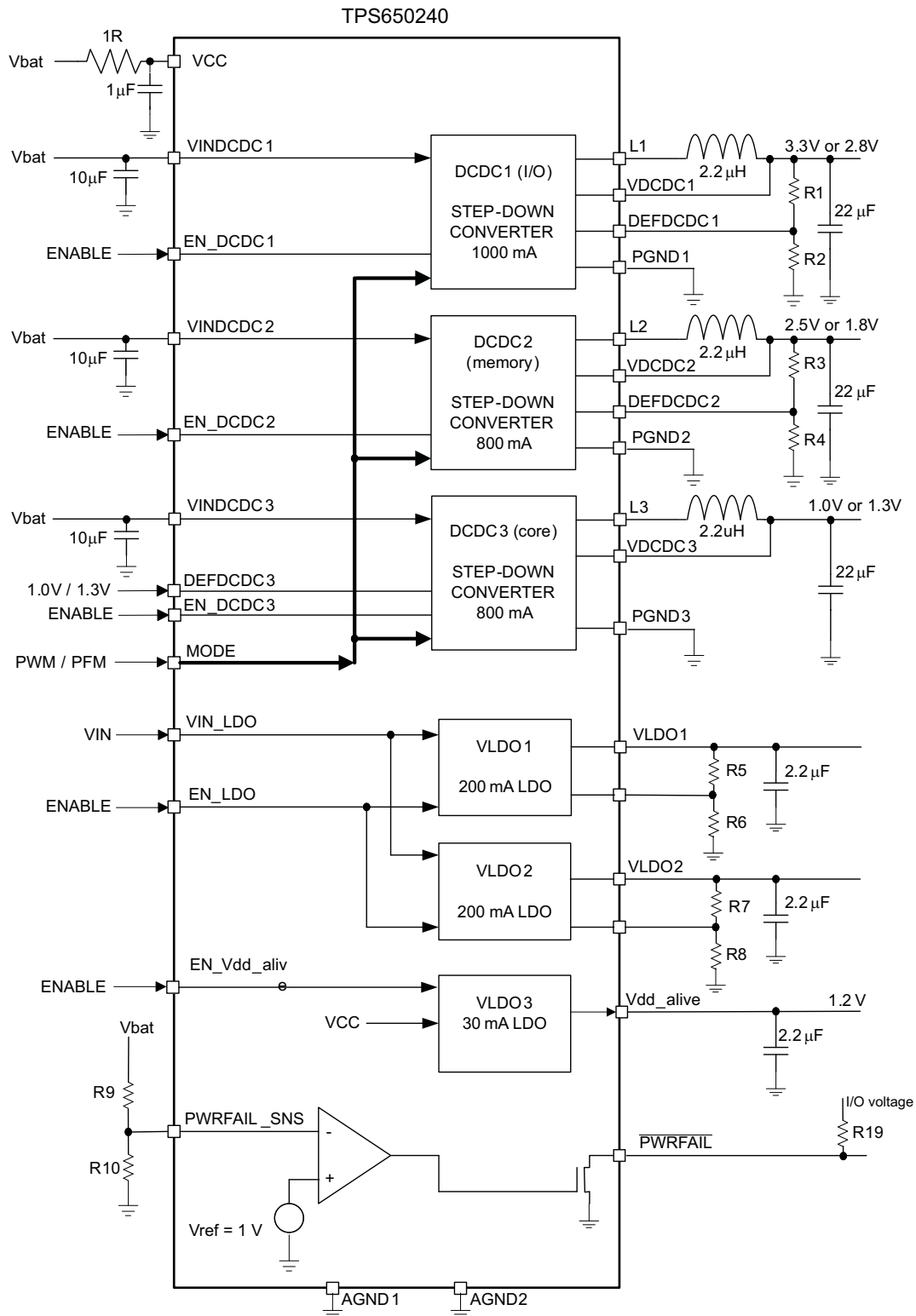

TYPICAL CHARACTERISTICS

Parameter Measurement Information

Graphs were taken using the EVM with the following inductor/output capacitor combinations:

CONVERTER	INDUCTOR	OUTPUT CAPACITOR	OUTPUT CAPACITOR VALUE
DCDC1	VLCF4020-3R3	C2012X5R0J226M	22 μ F
DCDC2	VLCF4020-2R2	C2012X5R0J226M	22 μ F
DCDC3	LPS3010-222	C2012X5R0J226M	22 μ F

Table of Graphs

			FIGURE
η	Efficiency VDCDC1	vs Load current PWM/PFM; $V_O = 3.3$ V	Figure 1
η	Efficiency VDCDC1	vs Load current PWM; $V_O = 3.3$ V	Figure 2
η	Efficiency VDCDC2	vs Load current PWM/PFM; $V_O = 1.8$ V	Figure 3
η	Efficiency VDCDC2	vs Load current PWM; $V_O = 1.8$ V	Figure 4
η	Efficiency VDCDC3	vs Load current PWM/PFM; $V_O = 1.3$ V	Figure 5
η	Efficiency VDCDC3	vs Load current PWM; $V_O = 1.3$ V	Figure 6
	Line transient response VDCDC1		Figure 7
	Line transient response VDCDC2		Figure 8
	Line transient response VDCDC3		Figure 9
	Load transient response VDCDC1		Figure 10
	Load transient response VDCDC2		Figure 11
	Load transient response VDCDC3		Figure 12
	Output voltage ripple DCDC2; PFM mode		Figure 13
	Output voltage ripple DCDC2; PWM mode		Figure 14
	Load regulation for Vdd_alive		Figure 15
	Start-up VDCDC1 to VDCDC3		Figure 16
	Start-up LDO1 and LDO2		Figure 17

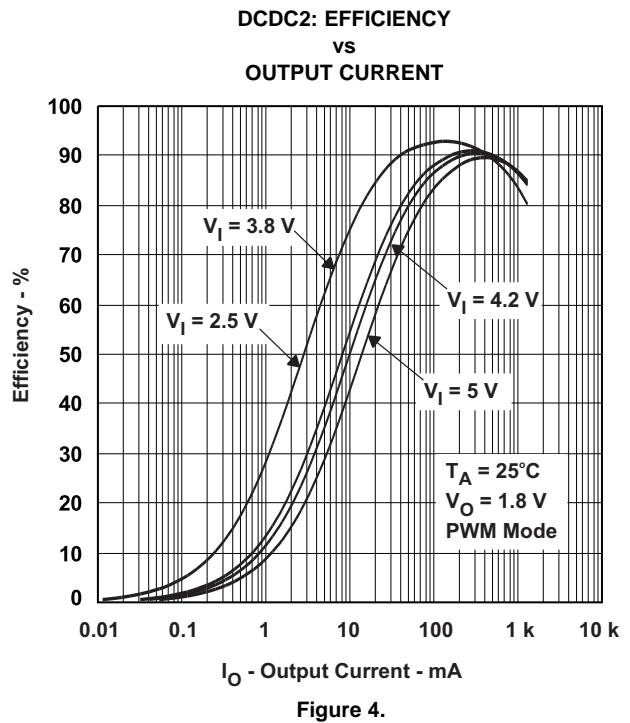
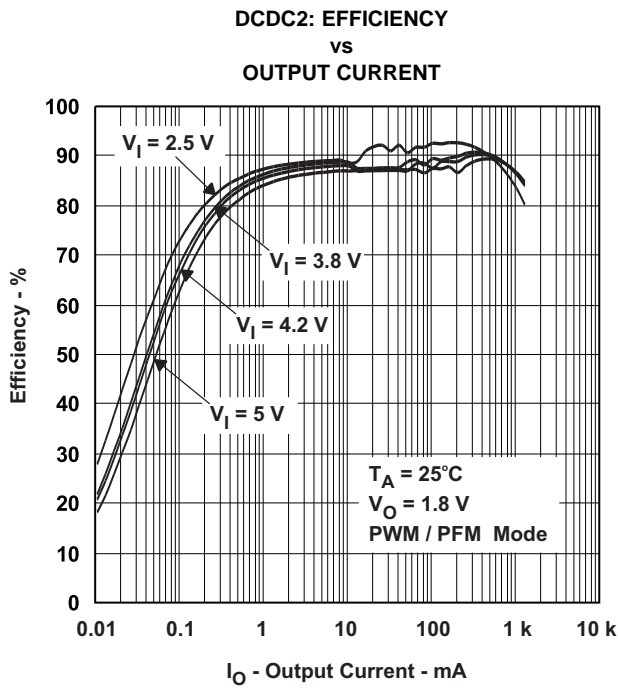
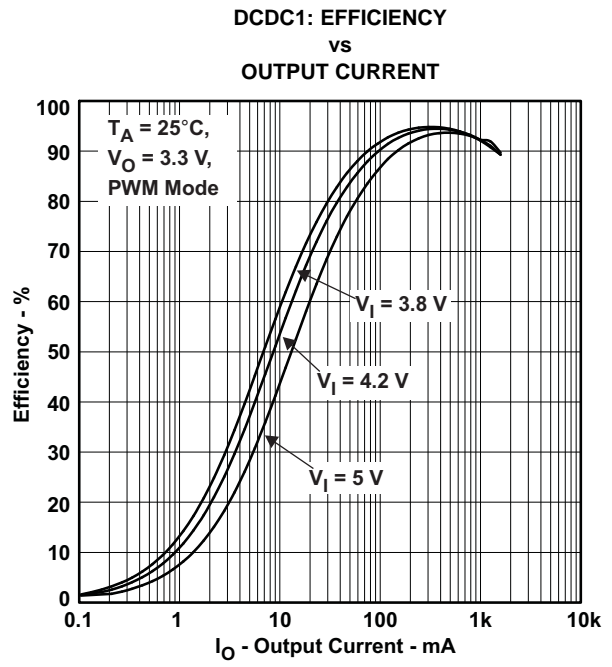
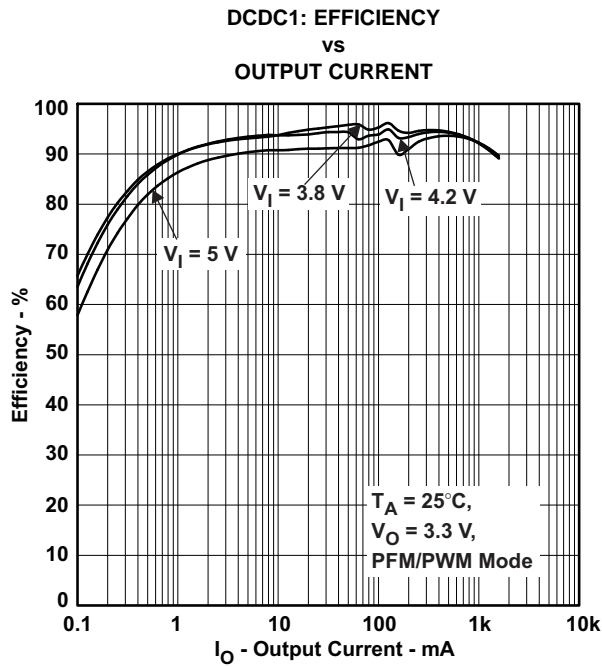

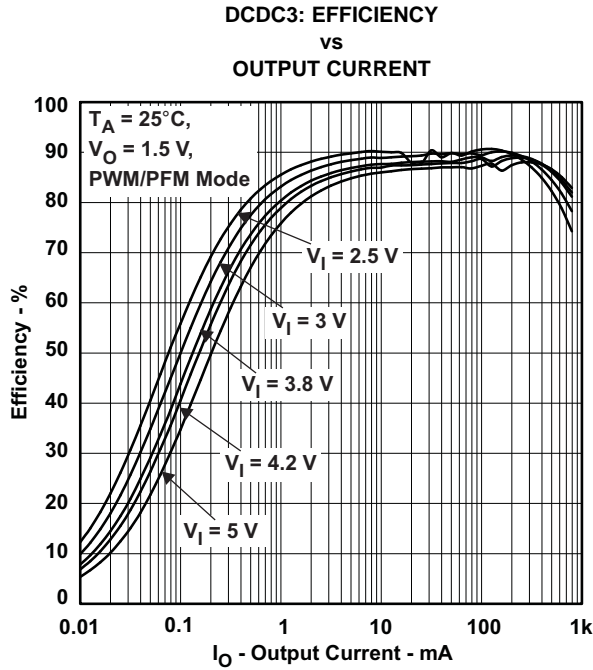

Figure 5.

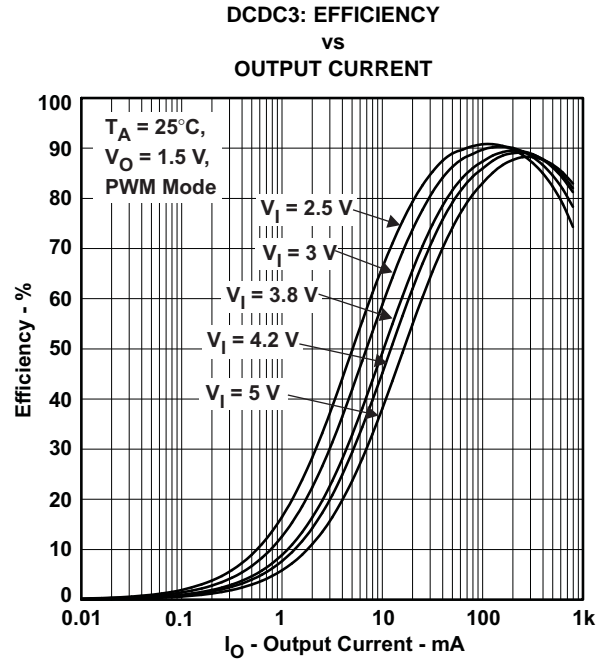

Figure 6.

VDCDC1 LINE TRANSIENT RESPONSE

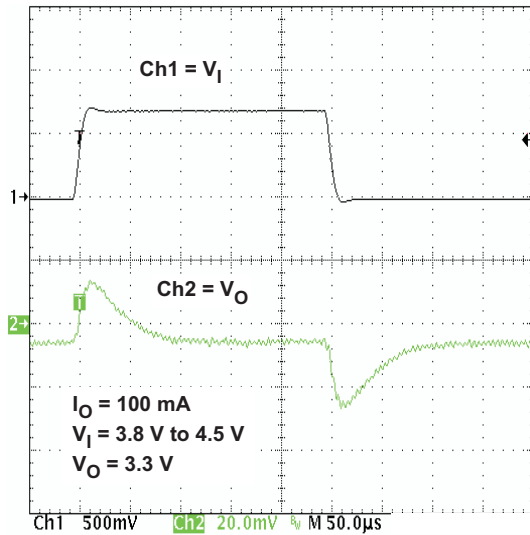

Figure 7.

VDCDC2 LINE TRANSIENT RESPONSE

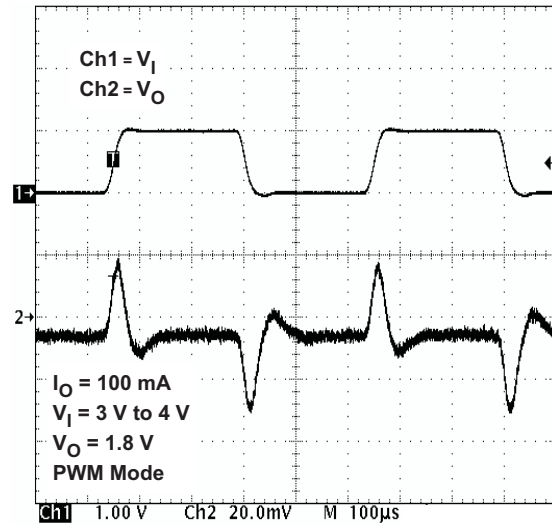

Figure 8.

VDCDC3 LINE TRANSIENT RESPONSE

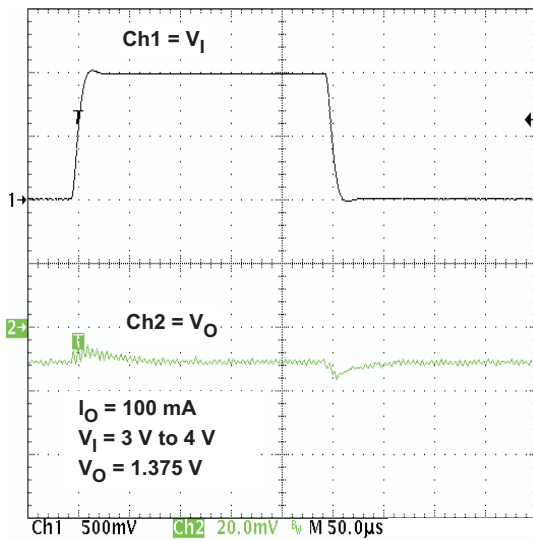

Figure 9.

VDCDC1 LOAD TRANSIENT RESPONSE

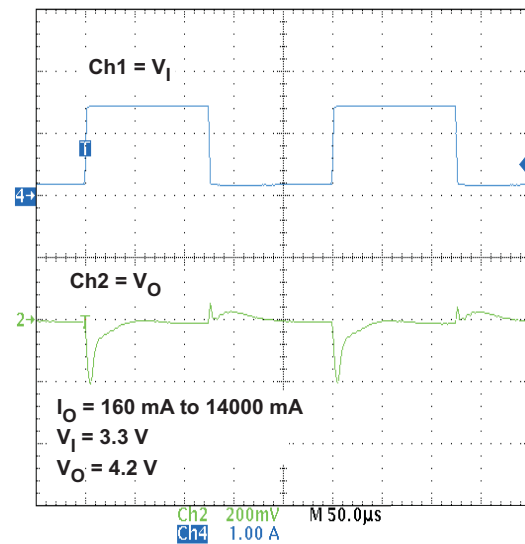

Figure 10.

VDCDC2 LOAD TRANSIENT RESPONSE

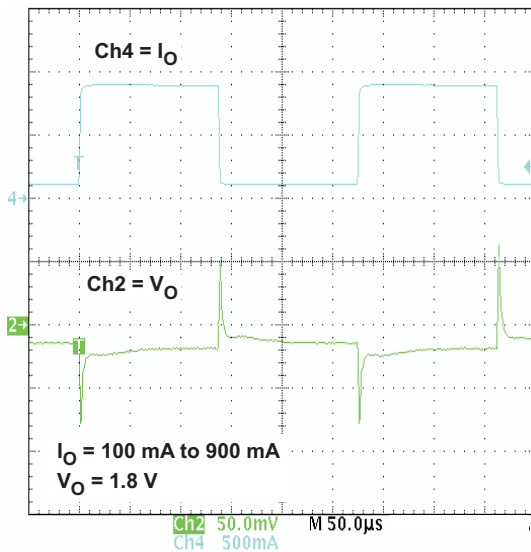

Figure 11.

VDCDC3 LOAD TRANSIENT RESPONSE

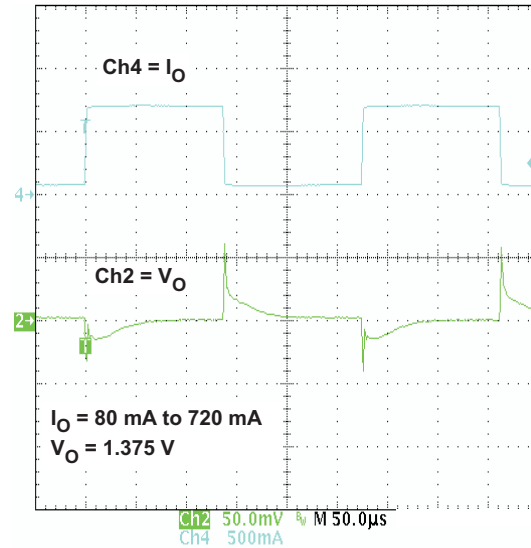

Figure 12.

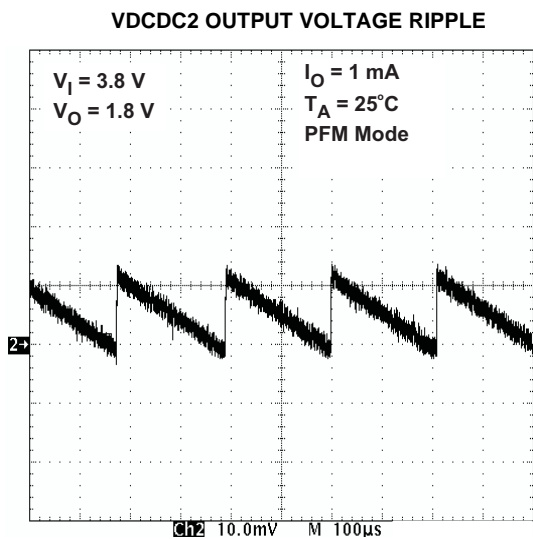

Figure 13.

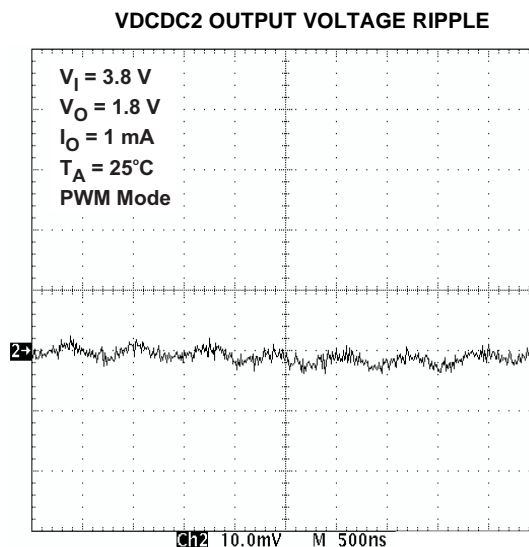

Figure 14.

**VDD_ALIVE OUTPUT VOLTAGE
vs
OUTPUT CURRENT**

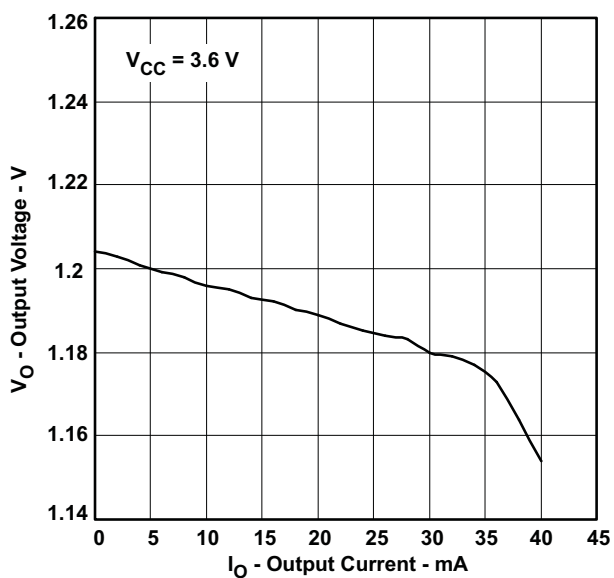

Figure 15.

STARTUP VDCDC1, VDCDC2, VDCDC3

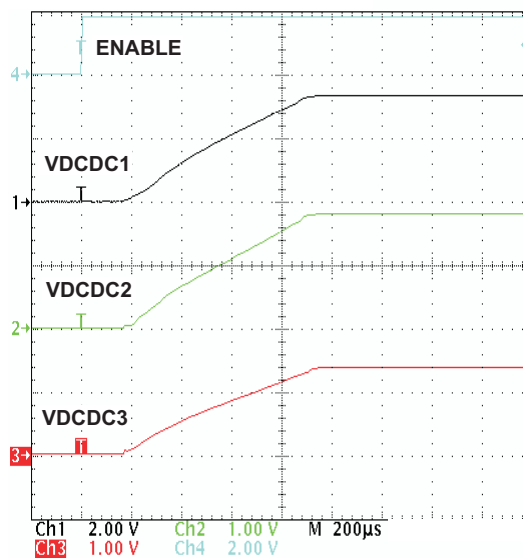

Figure 16.

STARTUP LDO1 AND LDO2

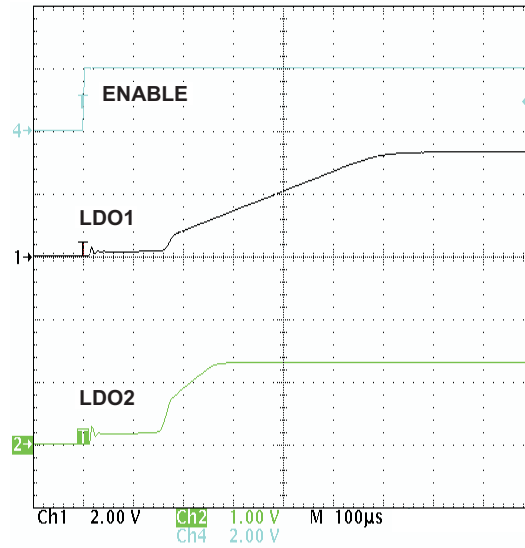

Figure 17.

DETAILED DESCRIPTION

STEP-DOWN CONVERTERS, VDCDC1, VDCDC2 AND VDCDC3

The TPS65024x incorporate three synchronous step-down converters operating typically at 2.25MHz fixed frequency PWM (Pulse Width Modulation) at moderate to heavy load currents. At light load currents the converters automatically enter Power Save Mode and operate with PFM (Pulse Frequency Modulation). VDCDC1 delivers up to 1.6A, VDCDC2 is capable of delivering up to 1.0A of output current while the VDCDC3 converter is capable of delivering up to 800mA.

The converter output voltages can be programmed via the DEFDCDC1, DEFDCDC2 and DEFDCDC3 pins. The pins can either be connected to GND, VCC or to a resistor divider between the output voltage and GND. The VDCDC1 converter defaults to 2.80V or 3.3V depending on the DEFDCDC1 configuration pin, if DEFDCDC1 is tied to ground the default is 2.80V, if it is tied to VCC the default is 3.3V. When the DEFDCDC1 pin is connected to a resistor divider, the output voltage can be set in the range of 0.6V to VINDCDC1 V. Reference the section on Output Voltage Selection for details on setting the output voltage range.

The VDCDC2 converter defaults to 1.8V or 2.5V depending on the DEFDCDC2 configuration pin, if DEFDCDC2 is tied to ground the default is 1.8V, if it is tied to VCC the default is 2.5V. When the DEFDCDC2 pin is connected to a resistor divider, the output voltage can be set in the range of 0.6V to VINDCDC2 V.

The VDCDC3 converter defaults to 1.0V or 1.3V for the TPS650240 depending on the DEFDCDC3 configuration pin, if DEFDCDC3 is tied to ground the default is 1.0V, if it is tied to VCC the default is 1.3V. The DEFDCDC3 pin cannot be connected to a resistor divider. In opposition to DEFDCDC1 and DEFDCDC2, the DEFDCDC3 pin can be used to change the core voltage during operation by changing its logic level from HIGH to LOW or vice versa. TPS65024x allow different voltages for the VDCDC3 converter. See [Table 4](#) for the default voltage options.

During PWM operation the converters use a unique fast response voltage mode controller scheme with input voltage feed-forward to achieve good line and load regulation allowing the use of small ceramic input and output capacitors. At the beginning of each clock cycle initiated by the clock signal, the P-channel MOSFET switch is turned on and the inductor current ramps up until the comparator trips and the control logic turns off the switch. The current limit comparator also turns off the switch in case the current limit of the P-channel switch is exceeded. After the adaptive dead time used to prevent shoot through current, the N-channel MOSFET rectifier is turned on and the inductor current ramps down. The next cycle is initiated by the clock signal again turning off the N-channel rectifier and turning on the P-channel switch.

The three DC/DC converters operate synchronized to each other, with the VDCDC1 converter as the master. A 180° phase shift between the VDCDC1 switch turn on and the VDCDC2 and a further 90° shift to the VDCDC3 switch turn on decreases the input RMS current and smaller input capacitors can be used. This is optimized for a typical application where the VDCDC1 converter regulates a Li-Ion battery voltage of 3.7V to 3.3V, the VDCDC2 converter from 3.7V to 2.5V and the VDCDC3 converter from 3.7V to 1.5V.

POWER SAVE MODE OPERATION

As the load current decreases, the converters enter Power Save Mode operation. During Power Save Mode the converters operate in a burst mode (PFM mode) with a frequency between 1.125MHz and 2.25MHz for one burst cycle. However, the frequency between different burst cycles depends on the actual load current and is typically far less than the switching frequency, with a minimum quiescent current to maintain high efficiency.

In order to optimize the converter efficiency at light load the average current is monitored and if in PWM mode the inductor current remains below a certain threshold, then Power Save Mode is entered. The typical threshold to enter Power Save Mode can be calculated as follows:

$$I_{\text{PFMDCDC1enter}} = \frac{V_{\text{INDCDC 1}}}{24 \Omega}$$

$$I_{\text{PFMDCDC2enter}} = \frac{V_{\text{INDCDC 2}}}{26 \Omega}$$

$$I_{\text{PFMDCDC3leave}} = \frac{V_{\text{INDCDC 3}}}{39 \Omega}$$

(1)

During Power Save Mode the output voltage is monitored with a comparator and by maximum skip burst width. As the output voltage falls below the threshold, set to the nominal V_O , the P-channel switch turns on and the converter effectively delivers a constant current as defined below.

$$I_{PFMDCDC1\text{leave}} = \frac{V_{INDCDC\ 1}}{18\ \Omega}$$

$$I_{PFMDCDC2\text{leave}} = \frac{V_{INDCDC\ 2}}{20\ \Omega}$$

$$I_{PFMDCDC3\text{enter}} = \frac{V_{INDCDC\ 3}}{29\ \Omega} \quad (2)$$

If the load is below the delivered current then the output voltage rises until the same threshold is crossed in the other direction. All switching activity ceases, reducing the quiescent current to a minimum until the output voltage has again dropped below the threshold. The power save mode is exited, and the converter returns to PWM mode if either of the following conditions are met:

1. The output voltage drops 2% below the nominal V_O due to increased load current
2. The PFM burst time exceeds $16 \times 1/f_s$ (7.1 μ s typical)

These control methods reduce the quiescent current to typically 14 μ A per converter and the switching activity to a minimum thus achieving the highest converter efficiency. Setting the comparator thresholds at the nominal output voltage at light load current results in a very low output voltage ripple. The ripple depends on the comparator delay and the size of the output capacitor; increasing capacitor values makes the output ripple tend to zero. Power Save Mode can be disabled by pulling the MODE pin high. This forces all DC/DC converters into fixed frequency PWM mode.

SOFT START

Each of the three converters has an internal soft start circuit that limits the inrush current during start-up. The soft start is realized by using a very low current to initially charge the internal compensation capacitor. The soft start time is typically 750 μ s if the output voltage ramps from 5% to 95% of the final target value. If the output is already pre-charged to some voltage when the converter is enabled, then this time is reduced proportionally. There is a short delay of typically 170 μ s between the converter being enabled and switching activity actually starting. This is to allow the converter to bias itself properly, to recognize if the output is pre-charged, and if so, to prevent discharging of the output while the internal soft start ramp catches up with the output voltage.

100% DUTY CYCLE LOW DROPOUT OPERATION

The TPS65024x converters offer a low input to output voltage difference while still maintaining operation with the use of the 100% duty cycle mode. In this mode the P-channel switch is constantly turned on. This is particularly useful in battery-powered applications to achieve the longest operation time by taking full advantage of the whole battery voltage range. The minimum input voltage required to maintain DC regulation depends on the load current and output voltage and can be calculated as:

$$V_{in\text{min}} = V_{out\text{min}} + I_{out\text{max}} \times (R_{DSon\text{max}} + R_L) \quad (3)$$

With:

$I_{out\text{max}}$ = Maximum load current (note: ripple current in the inductor is zero under these conditions)

$R_{DSon\text{max}}$ = Maximum P-channel switch R_{DSon}

R_L = DC resistance of the inductor

$V_{out\text{min}}$ = Nominal output voltage minus 2% tolerance limit

LOW DROPOUT VOLTAGE REGULATORS

The low dropout voltage regulators are designed to operate well with low value ceramic input and output capacitors. They operate with input voltages down to 1.5V. The LDOs offer a maximum dropout voltage of 300mV at the rated output current. Each LDO sports a current limit feature. Both LDOs are enabled by the EN_LDO pin. The LDOs also have reverse conduction prevention. This allows the possibility to connect external regulators in parallel in systems with a backup battery. The TPS65024x step-down and LDO voltage regulators automatically power down when the Vcc voltage drops below the UVLO threshold or when the junction temperature rises above 160°C.

UNDERVOLTAGE LOCKOUT

The undervoltage lockout circuit for the five regulators on the TPS65024x prevents the device from malfunctioning at low input voltages and from excessive discharge of the battery. It disables the converters and LDOs. The UVLO circuit monitors the Vcc pin; the threshold is set internally to 2.35V with 5% (120mV) hysteresis. Note that when any of the DC/DC converters are running there is an input current at the Vcc pin, which can be up to 3mA when all three converters are running in PWM mode. This current needs to be taken into consideration if an external RC filter is used at the Vcc pin to remove switching noise from the TPS65024x internal analog circuitry supply. See the Vcc-Filter section for details on the external RC filter.

POWER-UP SEQUENCING

The TPS65024x power-up sequencing is designed to be entirely flexible and customer driven; this is achieved simply by providing separate enable pins for each switch-mode converter and a common enable signal for LDO1 and LDO2. The relevant control pins are described in [Table 1](#).

Table 1. Control Pins for DCDC Converters

PIN NAME	INPUT/ OUTPUT	FUNCTION
DEFDCDC3	I	Defines the default voltage of the VDCDC3 switching converter. See Table 4 for details.
DEFDCDC2	I	Defines the default voltage of the VDCDC2 switching converter. DEFDCDC2 = 0 defaults VDCDC2 to 1.8V, DEFDCDC2 = VCC defaults VDCDC2 to 2.5V.
DEFDCDC1	I	Defines the default voltage of the VDCDC1 switching converter. DEFDCDC1 = 0 defaults VDCDC1 to 2.80V, DEFDCDC1 = VCC defaults VDCDC1 to 3.3V.
EN_DCDC3	I	Set EN_DCDC3 = 0 to disable or EN_DCDC3 = 1 to enable the VDCDC3 converter
EN_DCDC2	I	Set EN_DCDC2 = 0 to disable or EN_DCDC2 = 1 to enable the VDCDC2 converter
EN_DCDC1	I	Set EN_DCDC1 = 0 to disable or EN_DCDC1 = 1 to enable the VDCDC1 converter

PWRFAIL

The $\overline{\text{PWRFAIL}}$ signal is generated by a voltage detector at the PWRFAIL_SNS input. The input signal is compared to a 1V threshold (falling edge) with 5% (50mV) hysteresis. $\overline{\text{PWRFAIL}}$ is an open drain output which is actively low when the input voltage at PWRFAIL_SNS is below the threshold.

DESIGN PROCEDURE

Inductor Selection for the dcdc Converters

The three converters operate with 2.2μH output inductors. Larger or smaller inductor values can be used to optimize performance of the device for specific conditions. The selected inductor has to be rated for its dc resistance and saturation current. The dc resistance of the inductor influences directly the efficiency of the converter. Therefore, an inductor with the lowest dc resistance should be selected for the highest efficiency.

For a fast transient response, a 2.2μH inductor in combination with a 22μF output capacitor is recommended. For an output voltage above 2.8V, an inductor value of 3.3μH minimum is required. Lower values result in an increased output voltage ripple in PFM mode. The minimum inductor value is 1.5μH, but an output capacitor of 22μF minimum is needed in this case.

[Equation 4](#) calculates the maximum inductor current under static load conditions. The saturation current of the inductor should be rated higher than the maximum inductor current as calculated with [Equation 4](#). This is recommended because during heavy load transient the inductor current rises above the calculated value.

$$\Delta I_L = V_{out} \times \frac{1 - \frac{V_{out}}{V_{in}}}{L \times f} \quad I_{Lmax} = I_{outmax} + \frac{\Delta I_L}{2} \quad (4)$$

With:

f = Switching frequency (2.25MHz typical)

L = Inductor value

ΔI_L = Peak-to-peak inductor ripple current

I_{Lmax} = Maximum inductor current

The highest inductor current occurs at maximum V_{in} .

Open core inductors have a soft saturation characteristic and they can usually handle higher inductor currents versus a comparable shielded inductor.

A more conservative approach is to select the inductor current rating just for the maximum switch current of the corresponding converter. Consideration must be given to the difference in the core material from inductor to inductor which has an impact on efficiency especially at high switching frequencies. See [Table 2](#) and the typical applications for possible inductors.

Table 2. Tested Inductors

DEVICE	INDUCTOR VALUE	TYPE	COMPONENT SUPPLIER
	3.3 μ H	LPS3015-332 (output current up to 1A)	Coilcraft
	2.2 μ H	LPS3015-222 (output current up to 1A)	Coilcraft
	3.3 μ H	VLFC4020T-3R3N1R5	TDK
	2.2 μ H	VLFC4020T-2R2N1R7	TDK
DCDC3 converter	2.2 μ H	LPS3010-222	Coilcraft
	2.2 μ H	LPS3015-222	Coilcraft
	2.2 μ H	VLFC4020-2R2	TDK

Output Capacitor Selection

The advanced Fast Response voltage mode control scheme of the inductive converters implemented in the TPS65024x allows the use of small ceramic capacitors with a typical value of 10 μ F for each converter, without having large output voltage under and overshoots during heavy load transients. Ceramic capacitors having low ESR values have the lowest output voltage ripple and are recommended. Refer to [Table 3](#) for recommended components.

If ceramic output capacitors are used, the capacitor RMS ripple current rating will always meet the application requirements. For completeness, the RMS ripple current is calculated as:

$$I_{RMSout} = V_{out} \times \frac{1 - \frac{V_{out}}{V_{in}}}{L \times f} \times \frac{1}{2 \times \sqrt{3}} \quad (5)$$

At nominal load current the inductive converters operate in PWM mode and the overall output voltage ripple is the sum of the voltage spike caused by the output capacitor ESR plus the voltage ripple caused by charging and discharging the output capacitor:

$$\Delta V_{out} = V_{out} \times \frac{1 - \frac{V_{out}}{V_{in}}}{L \times f} \times \left(\frac{1}{8 \times C_{out} \times f} + ESR \right) \quad (6)$$

Where the highest output voltage ripple occurs at the highest input voltage, V_{in} .

At light load currents the converters operate in Power Save Mode and output voltage ripple is dependent on the output capacitor value. The output voltage ripple is set by the internal comparator delay and the external capacitor. Typical output voltage ripple is less than 1% of the nominal output voltage.

Input Capacitor Selection

Because of the nature of the buck converter having a pulsating input current, a low ESR input capacitor is required for best input voltage filtering and minimizing interference with other circuits caused by high input voltage spikes. Each dc/dc converter requires a 10µF ceramic input capacitor on its input pin VINDCDCx. The input capacitor can be increased without any limit for better input voltage filtering. The Vcc pin should be separated from the input for the DC/DC converters. A filter resistor of up to 10Ω and a 1µF capacitor should be used for decoupling the Vcc pin from switching noise. Note that the filter resistor may affect the UVLO threshold since up to 3mA can flow via this resistor into the Vcc pin when all converters are running in PWM mode.

Table 3. Possible Capacitors

CAPACITOR VALUE	CASE SIZE	COMPONENT SUPPLIER		COMMENTS
22µF	1206	TDK	C3216X5R0J226M	Ceramic
22µF	1206	Taiyo Yuden	JMK316BJ226ML	Ceramic
22µF	0805	TDK	C2012X5R0J226MT	Ceramic
22µF	0805	Taiyo Yuden	JMK212BJ226MG	Ceramic
10µF	0805	Taiyo Yuden	JMK212BJ106M	Ceramic
10µF	0805	TDK	C2012X5R0J106M	Ceramic

Output Voltage Selection

The DEFDCDC1, DEFDCDC2, and DEFDCDC3 pins are used to set the output voltage for each step-down converter. See Table 4 for the default voltages if the pins are pulled to GND or to Vcc.

Table 4. Voltage Options

PIN		LEVEL	DEFAULT OUTPUT VOLTAGE
DEFDCDC1	All versions	VCC	3.3V
		GND	2.80V
DEFDCDC2	All versions	VCC	2.5V
		GND	1.8V
DEFDCDC3	TPS650241	VCC	1.375V
		GND	0.9V
	TPS650243	VCC	1.2V
		GND	1.0V
	TPS650244	VCC	1.55V
		GND	1.6V

If a different voltage is needed, an external resistor divider can be added to the DEFDCDC1 or DEFDCDC2 pin as shown below:

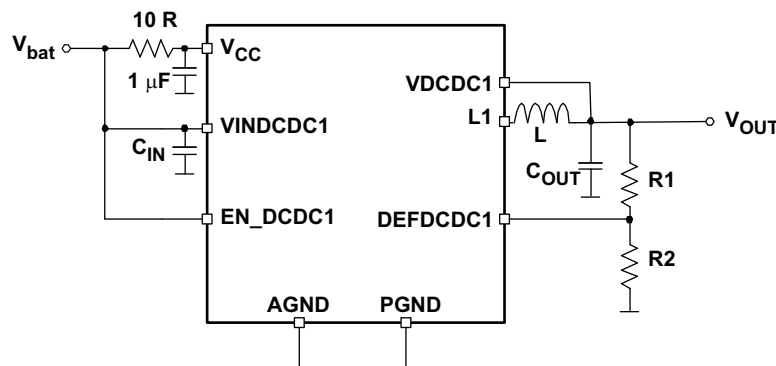

When a resistor divider is connected to DEFDCDC1 or DEFDCDC2, the output voltage can be set from 0.6V up to the input voltage V_{bat} . The total resistance ($R1+R2$) of the voltage divider should be kept in the 1MΩ range in order to maintain a high efficiency at light load. $V_{DEFDCDCx} = 0.6V$

$$V_{OUT} = V_{DEFDCDCx} \times \frac{R1 + R2}{R2}$$

$$R1 = R2 \times \left(\frac{V_{OUT}}{V_{DEFDCDCx}} \right) - R2$$

Voltage Change on VDCDC3

The output voltage of VDCDC3 can be changed during operation from, for example, 0.9V to 1.375V (TPS650241) and back. While the output voltage at VDCDC1 and VDCDC2 is fixed after the device exits undervoltage lockout (UVLO), the status of the DEFDCDC3 pin is sensed during operation and the voltage is changed as soon as the logic level on this pin changes from low to high or vice versa. Therefore it is not possible to connect a resistor divider to DEFDCDC3 and set a voltage different from the predefined voltages.

Vdd_alive Output

The Vdd_alive LDO is typically connected to the Vdd_alive input of the Samsung application processor. It provides an output voltage of 1.2V at 30mA. For the TPS650245, the output voltage is 1.1V. It is recommended to add a capacitor of 2.2µF minimum to the Vdd_alive pin. The LDO can be disabled by pulling the EN_Vdd_alive pin to GND.

LDO1 and LDO2

The LDOs in the TPS65024x are general purpose LDOs which are stable using ceramics capacitors. The minimum output capacitor required is 2.2µF. The LDOs output voltage can be changed to different voltages between 1.0V and Vin using an external resistor divider. Therefore they can also be used as general purpose LDOs in the application. The supply voltage for the LDOs needs to be connected to the VINLDO pin, giving the flexibility to connect the lowest voltage available in the system and therefore providing the highest efficiency.

The total resistance (R5+R6) of the voltage divider should be kept in the 1MΩ range in order to maintain high efficiency at light load. $V_{FBLDOx} = 1.0V$.

$$V_{OUT} = V_{FBLDOx} \times \frac{R5 + R6}{R6}$$

$$R5 = R6 \times \left(\frac{V_{OUT}}{V_{FBLDOx}} \right) - R6$$

Vcc-Filter

An RC filter connected at the Vcc input is used to keep noise from the internal supply for the bandgap and other analog circuitry. A typical value of 1Ω and 1µF is used to filter the switching spikes, generated by the DC/DC converters. A larger resistor than 10Ω should not be used because the current into Vcc of up to 2.5mA causes a voltage drop at the resistor causing the undervoltage lockout circuitry connected at Vcc internally to switch off too early.

APPLICATION INFORMATION

TYPICAL CONFIGURATION FOR THE TITAN 2 PROCESSOR

The core voltage is generated using DCDC2 with the output voltage set to 1.2V using a resistor divider at DEFDCDC2 as only DCDC2 can support an output current of up to 1.6A. DCDC3 is used for the memory voltage of 1.8V. As DCDC3 does not support an external resistor divider, the output voltage is programmed to 1.6V by setting DEFDCDC3 = HIGH. In addition, there is a resistor at the input of the internal voltage divider at pin VDCDC3 which adds another 200mV. The internal resistance at VDCDC3 when programmed to 1.6V is 480kΩ, so the external resistance needed to increase the output voltage from 1.6V to 1.8V is 60kΩ (62kΩ). The typical configuration for the Titan 2 processor is shown in Figure 18.

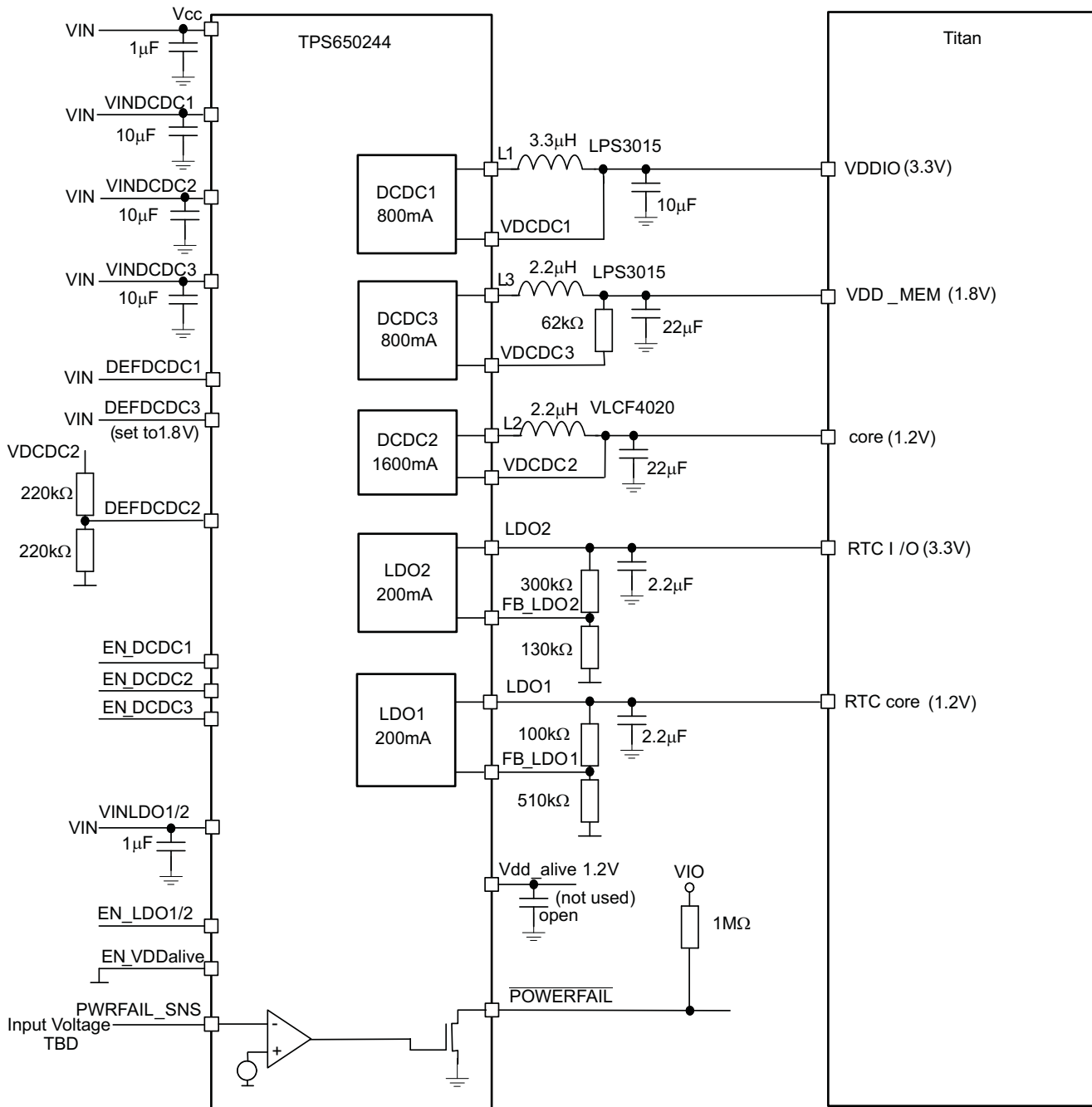

Figure 18. Titan Processor Configuration

TYPICAL CONFIGURATION FOR THE SAMSUNG PROCESSOR S3C6400-533MHZ

The typical configuration for the Samsung processor S3C6400-533MHz is shown in Figure 19.

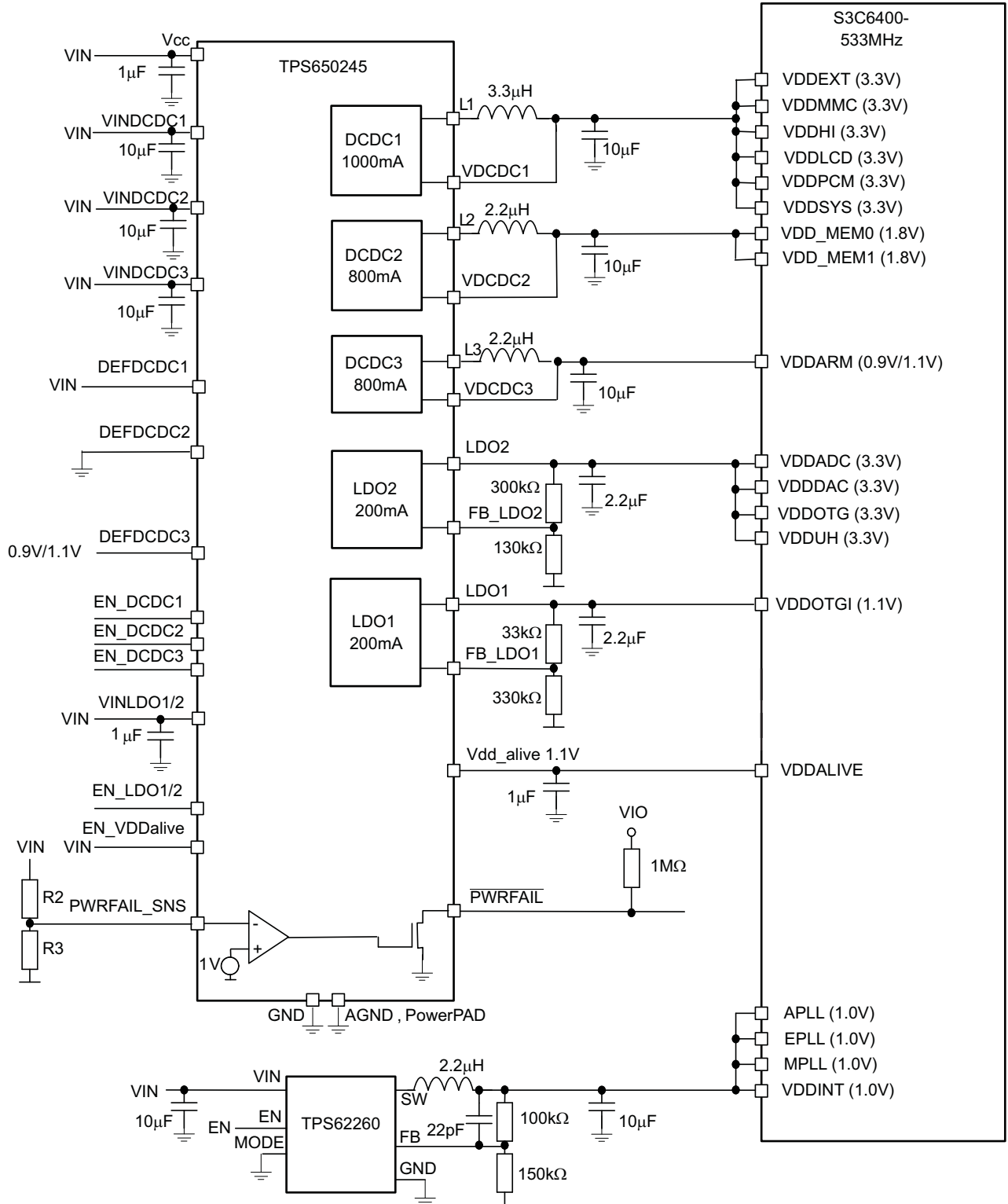

Figure 19. Samsung Processor Configuration

PACKAGING INFORMATION

Orderable Device	Status (1)	Package Type	Package Drawing	Pins	Package Qty	Eco Plan (2)	Lead/Ball Finish	MSL Peak Temp (3)	Op Temp (°C)	Device Marking (4/5)	Samples
TPS650241QRHBRQ1	ACTIVE	VQFN	RHB	32	3000	Green (RoHS & no Sb/Br)	CU NIPDAU	Level-3-260C-168 HR	-40 to 125	TPS 650241Q	Samples
TPS650243QRHBRQ1	ACTIVE	VQFN	RHB	32	3000	Green (RoHS & no Sb/Br)	CU NIPDAU	Level-3-260C-168 HR	-40 to 125	TPS 650243Q	Samples
TPS650244IRHBRQ1	ACTIVE	VQFN	RHB	32	3000	Green (RoHS & no Sb/Br)	CU NIPDAU	Level-3-260C-168 HR	-40 to 125	TPS 650244Q	Samples

(1) The marketing status values are defined as follows:

ACTIVE: Product device recommended for new designs.

LIFEBUY: TI has announced that the device will be discontinued, and a lifetime-buy period is in effect.

NRND: Not recommended for new designs. Device is in production to support existing customers, but TI does not recommend using this part in a new design.

PREVIEW: Device has been announced but is not in production. Samples may or may not be available.

OBsolete: TI has discontinued the production of the device.

(2) Eco Plan - The planned eco-friendly classification: Pb-Free (RoHS), Pb-Free (RoHS Exempt), or Green (RoHS & no Sb/Br) - please check <http://www.ti.com/productcontent> for the latest availability information and additional product content details.

TBD: The Pb-Free/Green conversion plan has not been defined.

Pb-Free (RoHS): TI's terms "Lead-Free" or "Pb-Free" mean semiconductor products that are compatible with the current RoHS requirements for all 6 substances, including the requirement that lead not exceed 0.1% by weight in homogeneous materials. Where designed to be soldered at high temperatures, TI Pb-Free products are suitable for use in specified lead-free processes.

Pb-Free (RoHS Exempt): This component has a RoHS exemption for either 1) lead-based flip-chip solder bumps used between the die and package, or 2) lead-based die adhesive used between the die and leadframe. The component is otherwise considered Pb-Free (RoHS compatible) as defined above.

Green (RoHS & no Sb/Br): TI defines "Green" to mean Pb-Free (RoHS compatible), and free of Bromine (Br) and Antimony (Sb) based flame retardants (Br or Sb do not exceed 0.1% by weight in homogeneous material)

(3) MSL, Peak Temp. -- The Moisture Sensitivity Level rating according to the JEDEC industry standard classifications, and peak solder temperature.

(4) There may be additional marking, which relates to the logo, the lot trace code information, or the environmental category on the device.

(5) Multiple Device Markings will be inside parentheses. Only one Device Marking contained in parentheses and separated by a "~" will appear on a device. If a line is indented then it is a continuation of the previous line and the two combined represent the entire Device Marking for that device.

Important Information and Disclaimer: The information provided on this page represents TI's knowledge and belief as of the date that it is provided. TI bases its knowledge and belief on information provided by third parties, and makes no representation or warranty as to the accuracy of such information. Efforts are underway to better integrate information from third parties. TI has taken and continues to take reasonable steps to provide representative and accurate information but may not have conducted destructive testing or chemical analysis on incoming materials and chemicals. TI and TI suppliers consider certain information to be proprietary, and thus CAS numbers and other limited information may not be available for release.

In no event shall TI's liability arising out of such information exceed the total purchase price of the TI part(s) at issue in this document sold by TI to Customer on an annual basis.

OTHER QUALIFIED VERSIONS OF TPS650241-Q1, TPS650243-Q1, TPS650244-Q1 :

- Catalog: [TPS650241](#), [TPS650243](#), [TPS650244](#)

NOTE: Qualified Version Definitions:

- Catalog - TI's standard catalog product

TAPE AND REEL INFORMATION

QUADRANT ASSIGNMENTS FOR PIN 1 ORIENTATION IN TAPE

*All dimensions are nominal

Device	Package Type	Package Drawing	Pins	SPQ	Reel Diameter (mm)	Reel Width W1 (mm)	A0 (mm)	B0 (mm)	K0 (mm)	P1 (mm)	W (mm)	Pin1 Quadrant
TPS650241QRHBRQ1	VQFN	RHB	32	3000	330.0	12.4	5.3	5.3	1.5	8.0	12.0	Q2
TPS650243QRHBRQ1	VQFN	RHB	32	3000	330.0	12.4	5.3	5.3	1.5	8.0	12.0	Q2
TPS650244IRHBRQ1	VQFN	RHB	32	3000	330.0	12.4	5.3	5.3	1.5	8.0	12.0	Q2

TAPE AND REEL BOX DIMENSIONS

*All dimensions are nominal

Device	Package Type	Package Drawing	Pins	SPQ	Length (mm)	Width (mm)	Height (mm)
TPS650241QRHBRQ1	VQFN	RHB	32	3000	367.0	367.0	35.0
TPS650243QRHBRQ1	VQFN	RHB	32	3000	367.0	367.0	35.0
TPS650244IRHBRQ1	VQFN	RHB	32	3000	367.0	367.0	35.0

GENERIC PACKAGE VIEW

RHB 32

VQFN - 1 mm max height

5 x 5, 0.5 mm pitch

PLASTIC QUAD FLATPACK - NO LEAD

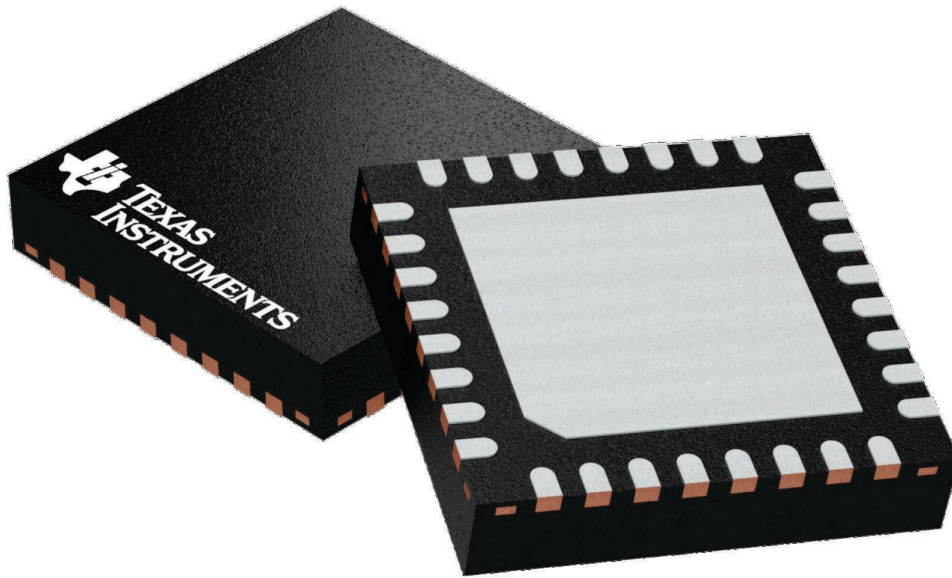

Images above are just a representation of the package family, actual package may vary.
Refer to the product data sheet for package details.

4224745/A

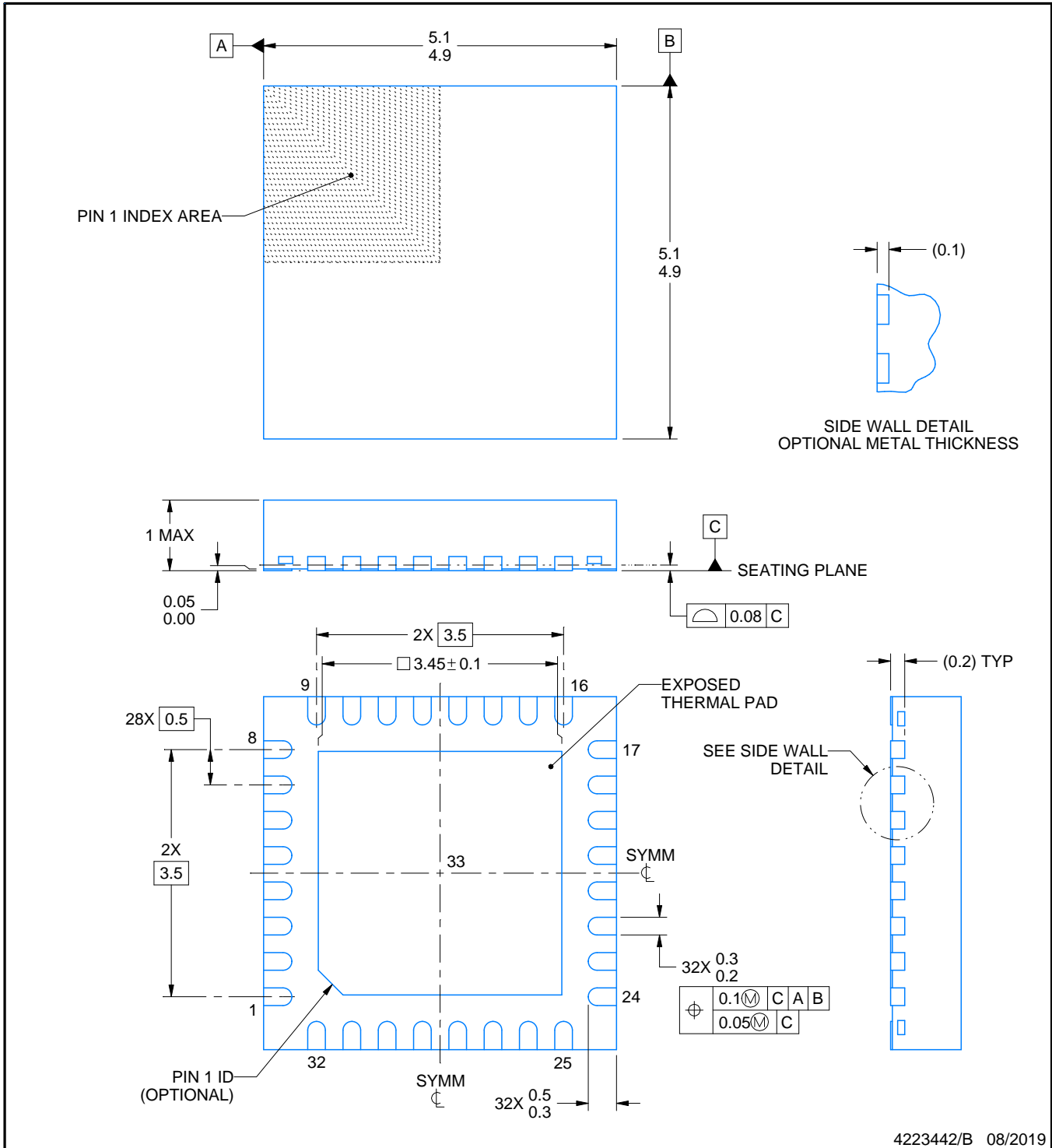
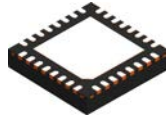

NOTES:

1. All linear dimensions are in millimeters. Any dimensions in parenthesis are for reference only. Dimensioning and tolerancing per ASME Y14.5M.
2. This drawing is subject to change without notice.
3. The package thermal pad must be soldered to the printed circuit board for thermal and mechanical performance.

EXAMPLE BOARD LAYOUT

RHB0032E

VQFN - 1 mm max height

PLASTIC QUAD FLATPACK - NO LEAD

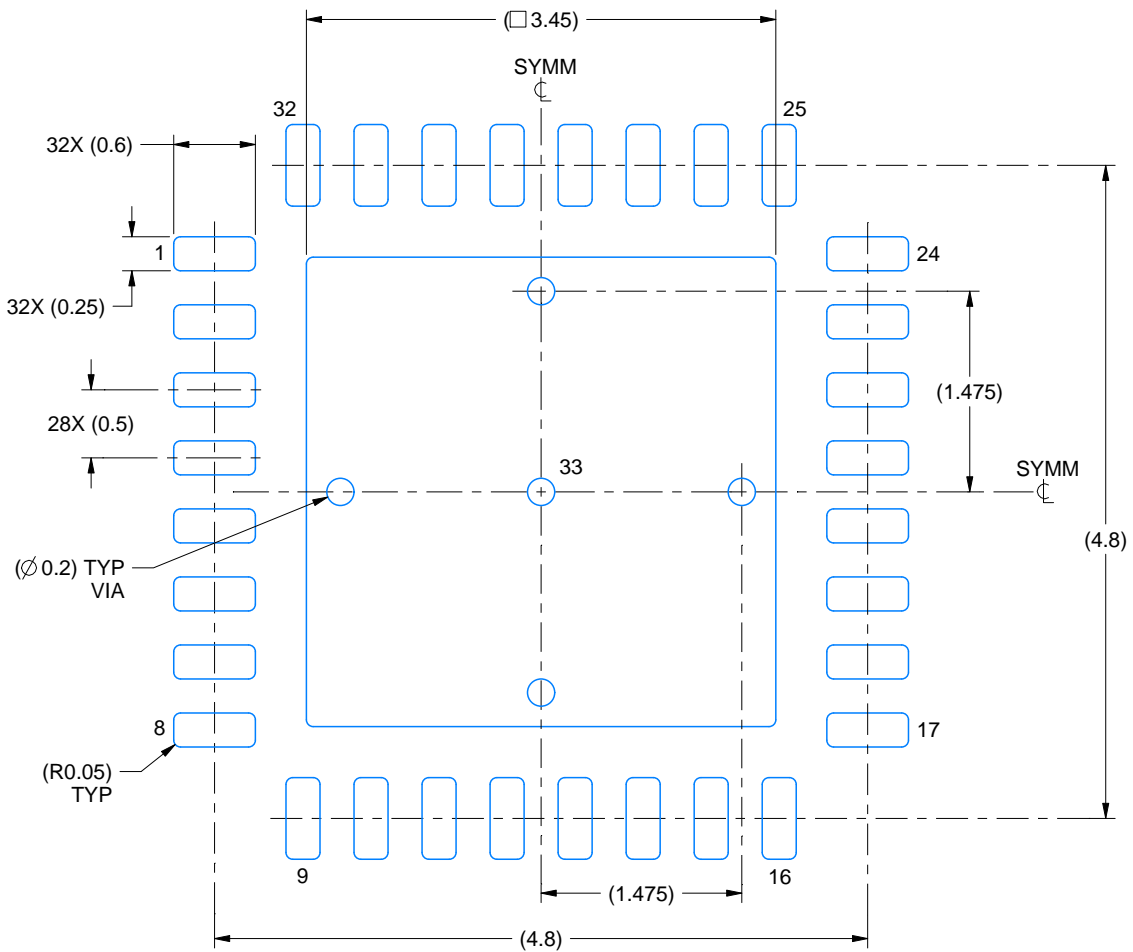

LAND PATTERN EXAMPLE
SCALE:18X

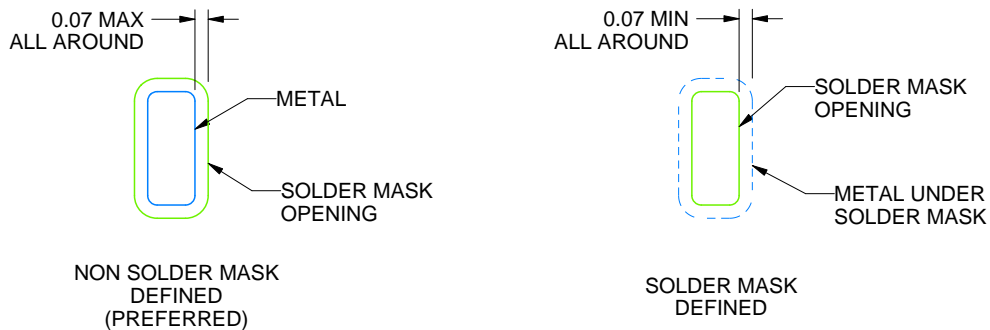

SOLDER MASK DETAILS

4223442/B 08/2019

NOTES: (continued)

4. This package is designed to be soldered to a thermal pad on the board. For more information, see Texas Instruments literature number SLUA271 (www.ti.com/lit/slua271).
5. Vias are optional depending on application, refer to device data sheet. If any vias are implemented, refer to their locations shown on this view. It is recommended that vias under paste be filled, plugged or tented.

EXAMPLE STENCIL DESIGN

RHB0032E

VQFN - 1 mm max height

PLASTIC QUAD FLATPACK - NO LEAD

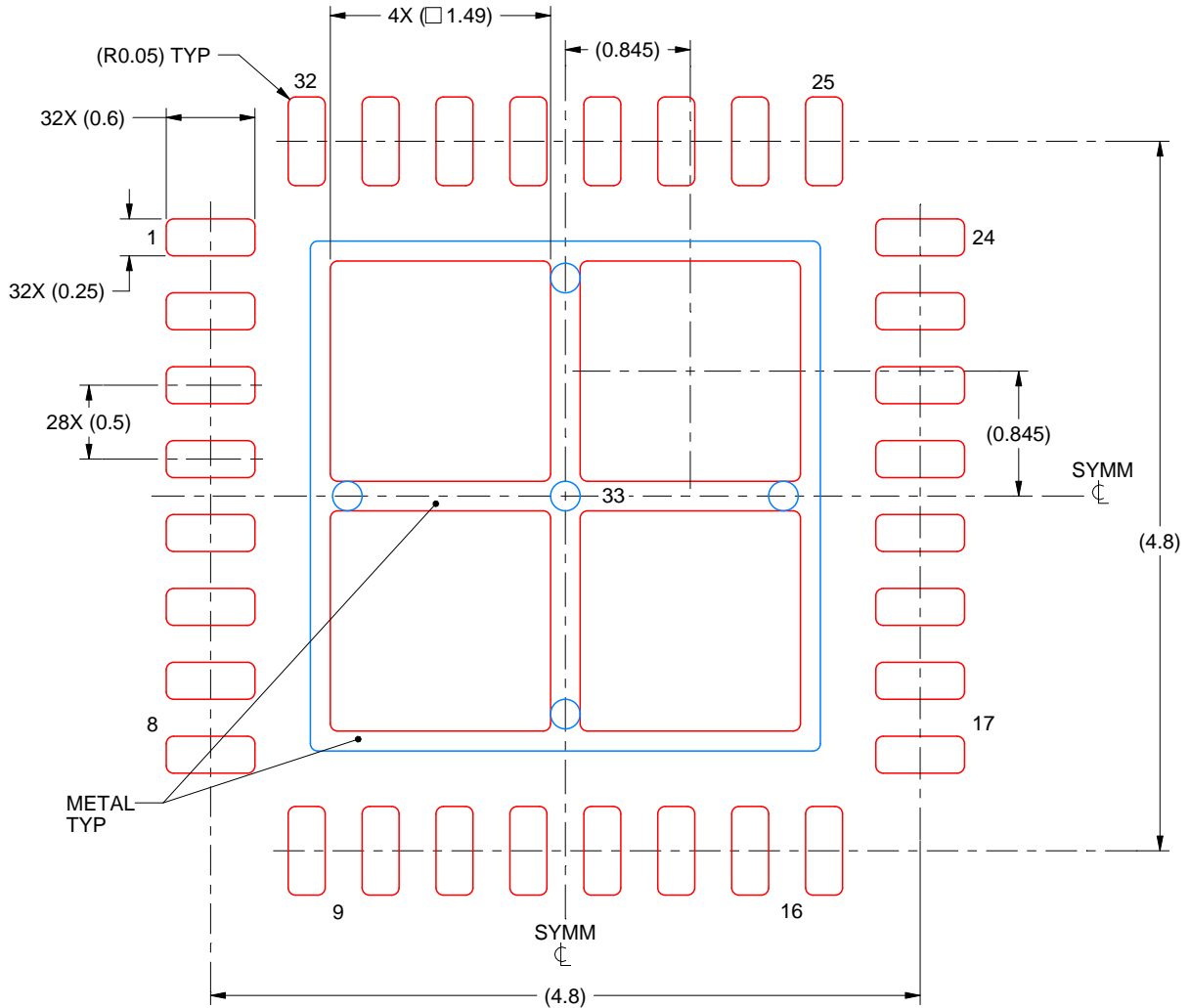

SOLDER PASTE EXAMPLE
BASED ON 0.125 mm THICK STENCIL

EXPOSED PAD 33:
75% PRINTED SOLDER COVERAGE BY AREA UNDER PACKAGE
SCALE:20X

4223442/B 08/2019

NOTES: (continued)

6. Laser cutting apertures with trapezoidal walls and rounded corners may offer better paste release. IPC-7525 may have alternate design recommendations.

IMPORTANT NOTICE AND DISCLAIMER

TI PROVIDES TECHNICAL AND RELIABILITY DATA (INCLUDING DATASHEETS), DESIGN RESOURCES (INCLUDING REFERENCE DESIGNS), APPLICATION OR OTHER DESIGN ADVICE, WEB TOOLS, SAFETY INFORMATION, AND OTHER RESOURCES "AS IS" AND WITH ALL FAULTS, AND DISCLAIMS ALL WARRANTIES, EXPRESS AND IMPLIED, INCLUDING WITHOUT LIMITATION ANY IMPLIED WARRANTIES OF MERCHANTABILITY, FITNESS FOR A PARTICULAR PURPOSE OR NON-INFRINGEMENT OF THIRD PARTY INTELLECTUAL PROPERTY RIGHTS.

These resources are intended for skilled developers designing with TI products. You are solely responsible for (1) selecting the appropriate TI products for your application, (2) designing, validating and testing your application, and (3) ensuring your application meets applicable standards, and any other safety, security, or other requirements. These resources are subject to change without notice. TI grants you permission to use these resources only for development of an application that uses the TI products described in the resource. Other reproduction and display of these resources is prohibited. No license is granted to any other TI intellectual property right or to any third party intellectual property right. TI disclaims responsibility for, and you will fully indemnify TI and its representatives against, any claims, damages, costs, losses, and liabilities arising out of your use of these resources.

TI's products are provided subject to TI's Terms of Sale (www.ti.com/legal/termsofsale.html) or other applicable terms available either on ti.com or provided in conjunction with such TI products. TI's provision of these resources does not expand or otherwise alter TI's applicable warranties or warranty disclaimers for TI products.

Mailing Address: Texas Instruments, Post Office Box 655303, Dallas, Texas 75265
Copyright © 2019, Texas Instruments Incorporated

Looking for pricing, stock, or lifecycle information?

Click below to explore more details on WIN SOURCE:

 [View TPS650244IRHBRQ1](#) on WIN SOURCE

 [Texas Instruments](#) Information

Optimize Your Supply Chain with WIN SOURCE Solutions

-  Global Sourcing Solution
-  Obsolete Management
-  Cost Control Management
-  Shortage Management
-  Alternative Solution
-  Excess Inventory Management