





## HIGH-VOLTAGE, LOW-DISTORTION, CURRENT-FEEDBACK OPERATIONAL AMPLIFIERS

### FEATURES

- **Low Distortion**
  - 66 dBc HD2 at 10 MHz,  $R_L = 100 \Omega$
  - 76 dBc HD3 at 10 MHz,  $R_L = 100 \Omega$
- **Low Noise**
  - 13 pA/ $\sqrt{\text{Hz}}$  Noninverting Current Noise
  - 13 pA/ $\sqrt{\text{Hz}}$  Inverting Current Noise
  - 2 nV/ $\sqrt{\text{Hz}}$  Voltage Noise
- **High Slew Rate: 5700 V/ $\mu\text{s}$  ( $G = 5$ ,  $V_O = 20 \text{ V}_{PP}$ )**
- **Wide Bandwidth: 160 MHz ( $G = 5$ ,  $R_L = 100 \Omega$ )**
- **High Output Current Drive:  $\pm 250 \text{ mA}$**
- **Wide Supply Range:  $\pm 5 \text{ V}$  to  $\pm 15 \text{ V}$**
- **Power-Down Feature: (THS3096 Only)**

### APPLICATIONS

- High-Voltage Arbitrary Waveform
- Power FET Driver
- Pin Driver
- VDSL Line Driver

### DESCRIPTION

The THS3092 and THS3096 are dual high-voltage, low-distortion, high speed, current-feedback amplifiers designed to operate over a wide supply range of  $\pm 5 \text{ V}$  to  $\pm 15 \text{ V}$  for applications requiring large, linear output signals such as Pin, Power FET, and VDSL line drivers.

The THS3096 features a power-down pin ( $\overline{\text{PD}}$ ) that puts the amplifier in low power standby mode, and lowers the quiescent current from 9.5 mA to 500  $\mu\text{A}$ .

The wide supply range combined with total harmonic distortion as low as -66 dBc at 10 MHz, in addition, to the high slew rate of 5700 V/ $\mu\text{s}$  makes the THS3092/6 ideally suited for high-voltage arbitrary waveform driver applications. Moreover, having the ability to handle large voltage swings driving into high-resistance and high-capacitance loads while maintaining good settling time performance makes the THS3092/6 ideal for Pin driver and PowerFET driver applications.

The THS3092 is offered in an 8-pin SOIC (D), and the 8-pin SOIC (DDA) packages with PowerPAD™. The THS3096 is offered in the 8-pin SOIC (D) and the 14-pin TSSOP (PWP) packages with PowerPAD.

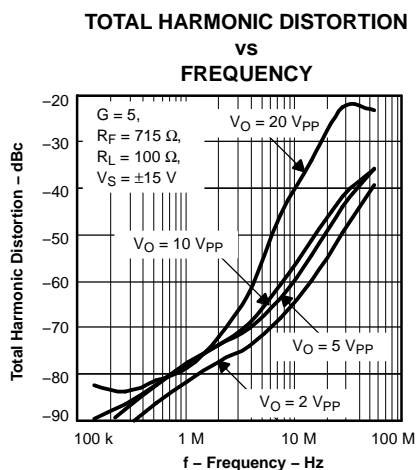

**TYPICAL ARBITRARY WAVEFORM  
GENERATOR OUTPUT DRIVE CIRCUIT**

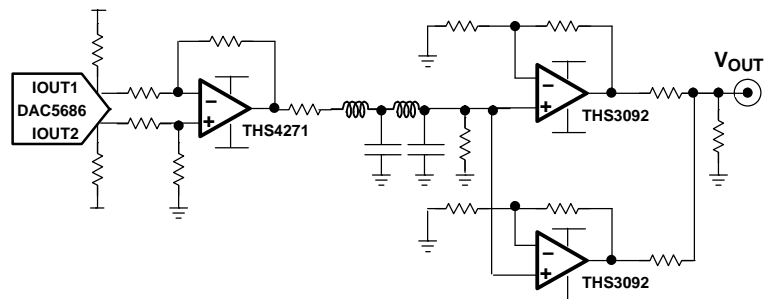

Please be aware that an important notice concerning availability, standard warranty, and use in critical applications of Texas Instruments semiconductor products and disclaimers thereto appears at the end of this data sheet.

PowerPAD is a trademark of Texas Instruments.



These devices have limited built-in ESD protection. The leads should be shorted together or the device placed in conductive foam during storage or handling to prevent electrostatic damage to the MOS gates.

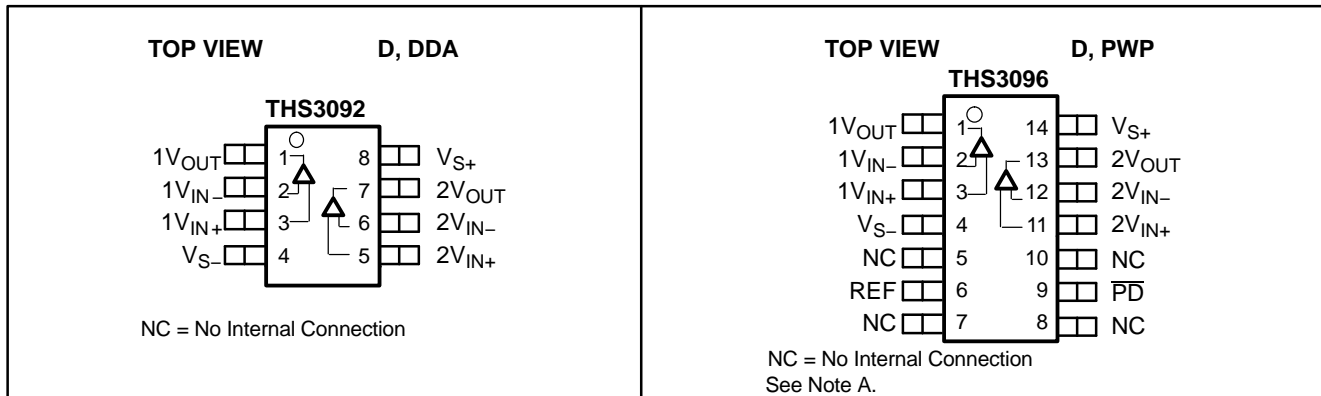

Note A: The devices with the power down option defaults to the ON state if no signal is applied to the  $\overline{PD}$  pin. Additionally, the REF pin functional range is from  $V_{S-}$  to  $(V_{S+} - 4 V)$ .

### ORDERING INFORMATION

PART NUMBER	PACKAGE TYPE	TRANSPORT MEDIA, QUANTITY
THS3092D	SOIC-8	Rails, 75
THS3092DR		Tape and Reel, 2500
THS3092DDA	SOIC-8-PP <sup>(1)</sup>	Rails, 75
THS3092DDAR		Tape and Reel, 2500
<i>Power-down</i>		
THS3096D	SOIC-8	Rails, 75
THS3096DR		Tape and Reel, 2500
THS3096PWP	TSSOP-14-PP <sup>(1)</sup>	Rails, 90
THS3096PWPR		Tape and Reel, 2000

(1) The PowerPAD is electrically isolated from all other pins.

### DISSIPATION RATING TABLE

PACKAGE	$\Theta_{JC}$ (°C/W)	$\Theta_{JA}$ (°C/W) <sup>(1)</sup>	POWER RATING <sup>(2)</sup>	
			$T_A \leq 25^\circ\text{C}$	$T_A = 85^\circ\text{C}$
D-8	38.3	97.5	1.02 W	410 mW
DDA-8 <sup>(3)</sup>	9.2	45.8	2.18 W	873 mW
PWP-14 <sup>(3)</sup>	2.07	37.5	2.67 W	1.07 W

- (1) This data was taken using the JEDEC standard High-K test PCB.
- (2) Power rating is determined with a junction temperature of 125°C. This is the point where distortion starts to substantially increase. Thermal management of the final PCB should strive to keep the junction temperature at or below 125°C for best performance and long term reliability.
- (3) The THS3092 and THS3096 may incorporate a PowerPAD™ on the underside of the chip. This acts as a heatsink and must be connected to a thermally dissipating plane for proper power dissipation. Failure to do so may result in exceeding the maximum junction temperature which could permanently damage the device. See TI Technical Brief SLMA002 for more information about utilizing the PowerPAD™ thermally enhanced package.

## RECOMMENDED OPERATING CONDITIONS

		MIN	MAX	UNIT
Supply voltage	Dual supply	±5	±15	V
	Single supply	10	30	
Operating free-air temperature, $T_A$		-40	85	°C

## ABSOLUTE MAXIMUM RATINGS

over operating free-air temperature (unless otherwise noted)<sup>(1)</sup>

	UNIT
Supply voltage, $V_{S-}$ to $V_{S+}$	33 V
Input voltage, $V_I$	± $V_S$
Differential input voltage, $V_{ID}$	± 4 V
Output current, $I_O$	350 mA
Continuous power dissipation	See Dissipation Ratings Table
Maximum junction temperature, $T_J$	150°C
Maximum junction temperature, continuous operation, long term reliability, $T_J^{(2)}$	125°C
Storage temperature, $T_{stg}$	-65°C to 150°C
Lead temperature 1,6 mm (1/16 inch) from case for 10 seconds	300°C
ESD ratings:	
HBM	2000
CDM	1500
MM	150

- (1) The absolute maximum ratings under any condition is limited by the constraints of the silicon process. Stresses above these ratings may cause permanent damage. Exposure to absolute maximum conditions for extended periods may degrade device reliability. These are stress ratings only, and functional operation of the device at these or any other conditions beyond those specified is not implied.
- (2) The maximum junction temperature for continuous operation is limited by package constraints. Operation above this temperature may result in reduced reliability and/or lifetime of the device.

## ELECTRICAL CHARACTERISTICS

$V_S = \pm 15\text{ V}$ ,  $R_F = 909\ \Omega$ ,  $R_L = 100\ \Omega$ , and  $G = 2$  (unless otherwise noted)

PARAMETER	TEST CONDITIONS	TYP	OVER TEMPERATURE				UNIT	MIN/TYP/ MAX
		25°C	25°C	0°C to 70°C	-40°C to 85°C			
<b>AC PERFORMANCE</b>								
Small-signal bandwidth, -3 dB	$G = 1$ , $R_F = 1.1\text{ k}\Omega$ , $V_O = 200\text{ mV}_{PP}$	135				MHz	TYP	
	$G = 2$ , $R_F = 909\ \Omega$ , $V_O = 200\text{ mV}_{PP}$	145						
	$G = 5$ , $R_F = 715\ \Omega$ , $V_O = 200\text{ mV}_{PP}$	160						
	$G = 10$ , $R_F = 604\ \Omega$ , $V_O = 200\text{ mV}_{PP}$	145						
0.1 dB bandwidth flatness	$G = 2$ , $R_F = 909\ \Omega$ , $V_O = 200\text{ mV}_{PP}$	50						
Large-signal bandwidth	$G = 5$ , $R_F = 715\ \Omega$ , $V_O = 5\text{ V}_{PP}$	150						
Slew rate (25% to 75% level)	$G = 2$ , $V_O = 10\text{-V step}$ , $R_F = 909\ \Omega$	4000				V/ $\mu$ s	TYP	
	$G = 5$ , $V_O = 20\text{-V step}$ , $R_F = 715\ \Omega$	5700						
Rise and fall time	$G = 2$ , $V_O = 5\text{-V}_{PP}$ , $R_F = 909\ \Omega$	5				ns	TYP	
Settling time to 0.1%	$G = -2$ , $V_O = 2\text{ V}_{PP}$ step	42				ns	TYP	
Settling time to 0.01%	$G = -2$ , $V_O = 2\text{ V}_{PP}$ step	72						
Harmonic distortion								
2nd Harmonic distortion	$G = 2$ , $R_F = 909\ \Omega$ , $V_O = 2\text{ V}_{PP}$ , $f = 10\text{ MHz}$	$R_L = 100\ \Omega$	66			dBc	TYP	
		$R_L = 1\text{ k}\Omega$	66					
3rd Harmonic distortion		$R_L = 100\ \Omega$	76					
		$R_L = 1\text{ k}\Omega$	78					
Input voltage noise	$f > 10\text{ kHz}$	2				nV / $\sqrt{\text{Hz}}$	TYP	
Noninverting input current noise	$f > 10\text{ kHz}$	13				pA / $\sqrt{\text{Hz}}$	TYP	
Inverting input current noise	$f > 10\text{ kHz}$	13				pA / $\sqrt{\text{Hz}}$	TYP	
Differential gain	$G = 2$ , $R_L = 150\ \Omega$ , $R_F = 909\ \Omega$	NTSC	0.013%			TYP		
		PAL	0.011%					
Differential phase		NTSC	0.020°					
		PAL	0.026°					
Crosstalk	$G = 2$ , $R_L = 100\ \Omega$ , $f = 10\text{ MHz}$	Ch 1 to 2	60			dB		
		Ch 2 to 1	56					
<b>DC PERFORMANCE</b>								
Transimpedance	$V_O = \pm 7.5\text{ V}$ , Gain = 1	850	350	300	300	k $\Omega$	MIN	
Input offset voltage	$V_{CM} = 0\text{ V}$	0.9	3	4	4	mV	MAX	
Average offset voltage drift				$\pm 10$	$\pm 10$	$\mu\text{V}/^\circ\text{C}$	TYP	
Noninverting input bias current		4	15	20	20	$\mu\text{A}$	MAX	
Average bias current drift				$\pm 20$	$\pm 20$	$\mu\text{A}/^\circ\text{C}$	TYP	
Inverting input bias current		3.5	15	20	20	$\mu\text{A}$	MAX	
Average bias current drift				$\pm 20$	$\pm 20$	$\mu\text{A}/^\circ\text{C}$	TYP	
Input offset current		1.7	10	15	15	$\mu\text{A}$	MAX	
Average offset current drift				$\pm 20$	$\pm 20$	$\mu\text{A}/^\circ\text{C}$	TYP	
<b>INPUT CHARACTERISTICS</b>								
Common-mode input range		$\pm 13.6$	$\pm 13.3$	$\pm 13$	$\pm 13$	V	MIN	
Common-mode rejection ratio	$V_{CM} = \pm 10\text{ V}$	78	68	65	65	dB	MIN	
Noninverting input resistance		1.3				M $\Omega$	TYP	
Noninverting input capacitance		0.1				pF	TYP	
Inverting input resistance		30				$\Omega$	TYP	
Inverting input capacitance		1.4				pF	TYP	

## ELECTRICAL CHARACTERISTICS (continued)

$V_S = \pm 15\text{ V}$ ,  $R_F = 909\ \Omega$ ,  $R_L = 100\ \Omega$ , and  $G = 2$  (unless otherwise noted)

PARAMETER	TEST CONDITIONS	TYP	OVER TEMPERATURE				UNIT	MIN/TYP/ MAX
		25°C	25°C	0°C to 70°C	-40°C to 85°C			
<b>OUTPUT CHARACTERISTICS</b>								
Output voltage swing	$R_L = 1\text{ k}\Omega$	$\pm 13.2$	$\pm 12.8$	$\pm 12.5$	$\pm 12.5$	V	MIN	
	$R_L = 100\ \Omega$	$\pm 12.5$	$\pm 12.1$	$\pm 11.8$	$\pm 11.8$			
Output current (sourcing)	$R_L = 40\ \Omega$	280	225	200	200	mA	MIN	
Output current (sinking)	$R_L = 40\ \Omega$	250	200	175	175	mA	MIN	
Output impedance	$f = 1\text{ MHz}$ , Closed loop	0.06				$\Omega$	TYP	
<b>POWER SUPPLY</b>								
Specified operating voltage		$\pm 15$	$\pm 16$	$\pm 16$	$\pm 16$	V	MAX	
Maximum quiescent current	Per channel	9.5	10.5	11	11	mA	MAX	
Minimum quiescent current		9.5	8.5	8	8	mA	MIN	
Power supply rejection (+PSRR)	$V_{S+} = 15.5\text{ V}$ to $14.5\text{ V}$ , $V_{S-} = 15\text{ V}$	75	70	65	65	dB	MIN	
Power supply rejection (-PSRR)	$V_{S+} = 15\text{ V}$ , $V_{S-} = -15.5\text{ V}$ to $-14.5\text{ V}$	73	68	65	65	dB	MIN	
<b>POWER-DOWN CHARACTERISTICS (THS3096 ONLY)</b>								
REF voltage range <sup>(1)</sup>		$V_{S+} - 4$				V	MAX	
		$V_{S-}$					MIN	
Power-down voltage level <sup>(1)</sup>	Enable	$\overline{PD} \geq \text{REF} + 2$					MIN	
	Disable	$\overline{PD} \leq \text{REF} + 0.8$					MAX	
Power-down quiescent current	$\overline{PD} = 0\text{ V}$	500	700	800	800	$\mu\text{A}$	MAX	
$V_{PD}$ quiescent current	$V_{PD} = 0\text{ V}$ , $\text{REF} = 0\text{ V}$ ,	11	15	20	20	$\mu\text{A}$	MAX	
	$V_{PD} = 3.3\text{ V}$ , $\text{REF} = 0\text{ V}$	11	15	20	20			
Turnon time delay	90% of final value	60				$\mu\text{s}$	TYP	
Turnoff time delay	10% of final value	150						

(1) For detailed information on the behavior of the powerdown circuit, see the Powerdown and [Powerdown Reference](#) sections in the [Application Information](#) of this data sheet.

## ELECTRICAL CHARACTERISTICS

$V_S = \pm 5\text{ V}$ ,  $R_F = 909\ \Omega$ ,  $R_L = 100\ \Omega$ , and  $G = 2$  (unless otherwise noted)

PARAMETER	TEST CONDITIONS	TYP	OVER TEMPERATURE				
		25°C	25°C	0°C to 70°C	-40°C to 85°C	UNIT	MIN/TYP/MAX
<b>AC PERFORMANCE</b>							
Small-signal bandwidth, -3 dB	$G = 1$ , $R_F = 1.1\text{ k}\Omega$ , $V_O = 200\text{ mV}_{PP}$	125				MHz	TYP
	$G = 2$ , $R_F = 909\ \Omega$ , $V_O = 200\text{ mV}_{PP}$	140					
	$G = 5$ , $R_F = 715\ \Omega$ , $V_O = 200\text{ mV}_{PP}$	145					
	$G = 10$ , $R_F = 604\ \Omega$ , $V_O = 200\text{ mV}_{PP}$	135					
0.1 dB bandwidth flatness	$G = 2$ , $R_F = 909\ \Omega$ , $V_O = 200\text{ mV}_{PP}$	42					
Large-signal bandwidth	$G = 2$ , $R_F = 909\ \Omega$ , $V_O = 5\text{ V}_{PP}$	125					
Slew rate (25% to 75% level)	$G = 2$ , $V_O = 5\text{-V step}$ , $R_F = 909\ \Omega$	1050				V/ $\mu$ s	TYP
	$G = 5$ , $V_O = 5\text{-V step}$ , $R_F = 715\ \Omega$	1350					
Rise and fall time	$G = 2$ , $V_O = 5\text{-V step}$ , $R_F = 909\ \Omega$	5				ns	TYP
Settling time to 0.1%	$G = -2$ , $V_O = 2\text{ V}_{PP}$ step	35				ns	TYP
Settling time to 0.01%	$G = -2$ , $V_O = 2\text{ V}_{PP}$ step	73					
<b>Harmonic distortion</b>							
2nd Harmonic distortion	$G = 2$ , $R_F = 909\ \Omega$ , $V_O = 2\text{ V}_{PP}$ , $f = 10\text{ MHz}$	$R_L = 100\ \Omega$	64			dBc	TYP
		$R_L = 1\text{ k}\Omega$	67				
3rd Harmonic distortion		$R_L = 100\ \Omega$	75				
		$R_L = 1\text{ k}\Omega$	75				
Input voltage noise	$f > 10\text{ kHz}$	2				nV / $\sqrt{\text{Hz}}$	TYP
Noninverting input current noise	$f > 10\text{ kHz}$	13				pA / $\sqrt{\text{Hz}}$	TYP
Inverting input current noise	$f > 10\text{ kHz}$	13				pA / $\sqrt{\text{Hz}}$	TYP
Differential gain	$G = 2$ , $R_L = 150\ \Omega$ , $R_F = 909\ \Omega$	NTSC	0.027%			TYP	
		PAL	0.025%				
Differential phase		NTSC	0.04°				
		PAL	0.05°				
Crosstalk	$G = 2$ , $R_L = 100\ \Omega$ , $f = 10\text{ kHz}$	Ch 1 to 2	60			dB	
		Ch 2 to 1	56				
<b>DC PERFORMANCE</b>							
Transimpedance	$V_O = \pm 2.5\text{ V}$ , Gain = 1	700	250	200	200	k $\Omega$	MIN
Input offset voltage	$V_{CM} = 0\text{ V}$	0.3	2	3	3	mV	MAX
Average offset voltage drift				$\pm 10$	$\pm 10$	$\mu\text{V}/^\circ\text{C}$	TYP
Noninverting input bias current		2	15	20	20	$\mu\text{A}$	MAX
Average bias current drift				$\pm 20$	$\pm 20$	$\mu\text{A}/^\circ\text{C}$	TYP
Inverting input bias current		5	15	20	20	$\mu\text{A}$	MAX
Average bias current drift				$\pm 20$	$\pm 20$	$\mu\text{A}/^\circ\text{C}$	TYP
Input offset current		1	10	15	15	$\mu\text{A}$	MAX
Average offset current drift				$\pm 20$	$\pm 20$	$\mu\text{A}/^\circ\text{C}$	TYP
<b>INPUT CHARACTERISTICS</b>							
Common-mode input range		$\pm 3.6$	$\pm 3.3$	$\pm 3$	$\pm 3$	V	MIN
Common-mode rejection ratio	$V_{CM} = \pm 2.0\text{ V}$ , $V_O = 0\text{ V}$	66	60	57	57	dB	MIN
Noninverting input resistance		1.1				M $\Omega$	TYP
Noninverting input capacitance		1.2				pF	TYP
Inverting input resistance		32				$\Omega$	TYP
Inverting input capacitance		1.5				pF	TYP

## ELECTRICAL CHARACTERISTICS (continued)

$V_S = \pm 5\text{ V}$ ,  $R_F = 909\ \Omega$ ,  $R_L = 100\ \Omega$ , and  $G = 2$  (unless otherwise noted)

PARAMETER	TEST CONDITIONS	TYP	OVER TEMPERATURE				UNIT	MIN/TYP/ MAX
		25°C	25°C	0°C to 70°C	-40°C to 85°C			
<b>OUTPUT CHARACTERISTICS</b>								
Output voltage swing	$R_L = 1\text{ k}\Omega$	$\pm 3.4$	$\pm 3.1$	$\pm 2.8$	$\pm 2.8$	V	MIN	
	$R_L = 100\ \Omega$	$\pm 3.1$	$\pm 2.7$	$\pm 2.5$	$\pm 2.5$			
Output current (sourcing)	$R_L = 10\ \Omega$	200	160	140	140	mA	MIN	
Output current (sinking)	$R_L = 10\ \Omega$	180	150	125	125	mA	MIN	
Output impedance	$f = 1\text{ MHz}$ , Closed loop	0.09				$\Omega$	TYP	
<b>POWER SUPPLY</b>								
Specified operating voltage		$\pm 5$	$\pm 4.5$	$\pm 4.5$	$\pm 4.5$	V	MAX	
Maximum quiescent current	Per channel	8.2	9	9.5	9.5	mA	MAX	
Minimum quiescent current		8.2	7	6.5	6.5	mA	MIN	
Power supply rejection (+PSRR)	$V_{S+} = 5.5\text{ V}$ to $4.5\text{ V}$ , $V_{S-} = -5\text{ V}$	73	68	63	63	dB	MIN	
Power supply rejection (-PSRR)	$V_{S+} = 5\text{ V}$ , $V_{S-} = -4.5\text{ V}$ to $5.5\text{ V}$	71	65	60	60	dB	MIN	
<b>POWER-DOWN CHARACTERISTICS (THS3096 ONLY)</b>								
REF voltage range <sup>(1)</sup>		$V_{S+} - 4$				V	MAX	
		$V_{S-}$					MIN	
Power-down voltage level <sup>(1)</sup>	Enable	$\overline{PD} \geq \text{REF} + 2$					MIN	
	Disable	$\overline{PD} \leq \text{REF} + 0.8$					MAX	
Power-down quiescent current	$\overline{PD} = 0\text{ V}$	300	500	600	600	$\mu\text{A}$	MAX	
$V_{PD}$ quiescent current	$V_{PD} = 0\text{ V}$ , REF = 0 V,	11	15	20	20	$\mu\text{A}$	MAX	
	$V_{PD} = 3.3\text{ V}$ , REF = 0 V	11	15	20	20			
Turnon time delay	90% of final value	60				$\mu\text{s}$	TYP	
Turnoff time delay	10% of final value	150						

(1) For detailed information on the behavior of the powerdown circuit, see the Powerdown and [Powerdown Reference](#) sections in the [Application Information](#) of this data sheet.

## TYPICAL CHARACTERISTICS

### TABLE OF GRAPHS

		FIGURE
<b><math>\pm 15\text{-V}</math> graphs</b>		
Noninverting frequency response		1, 2
Inverting frequency response		3
0.1 dB flatness		4
Noninverting frequency response		5
Inverting frequency response		6
Frequency response capacitive load		7
Recommended $R_{ISO}$	vs Capacitive load	8
2nd Harmonic distortion	vs Frequency	9, 11
3rd Harmonic distortion	vs Frequency	10, 12
Slew rate	vs Output voltage step	13, 14, 15
Noise	vs Frequency	16
Settling time		17, 18
Quiescent current	vs Supply voltage	19
Output voltage	vs Load resistance	20
Input bias and offset current	vs Case temperature	21
Input offset voltage	vs Case temperature	22

**TYPICAL CHARACTERISTICS (continued)**

		<b>FIGURE</b>
Transimpedance	vs Frequency	23
Rejection ratio	vs Frequency	24
Noninverting small signal transient response		25
Inverting large signal transient response		26, 27
Overdrive recovery time		28
Differential gain	vs Number of loads	29
Differential phase	vs Number of loads	30
Closed loop output impedance	vs Frequency	31
Crosstalk	vs Frequency	32
Power-down quiescent current	vs Supply voltage	33
Turnon and turnoff time delay		34

**TABLE OF GRAPHS**

		FIGURE
<b>±5-V graphs</b>		
Noninverting frequency response		35
Inverting frequency response		36
0.1 dB flatness		37
Noninverting frequency response		38
Inverting frequency response		39
Settling time		40
2nd Harmonic distortion	vs Frequency	41
3rd Harmonic distortion	vs Frequency	42
Slew rate	vs Output voltage step	43, 44, 45
Noninverting small signal transient response		46
Output voltage load resistance		47
Input bias and offset current	vs Case temperature	48
Overdrive recovery time		49
Rejection ratio	vs Frequency	50
Crosstalk	vs Frequency	51

**TYPICAL CHARACTERISTICS (±15 V)**

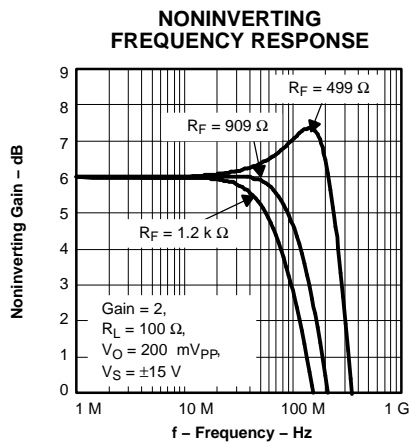

Figure 1.

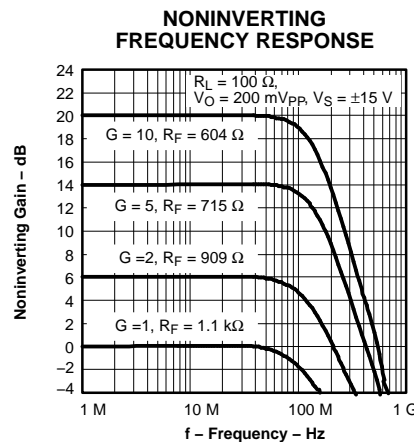

Figure 2.

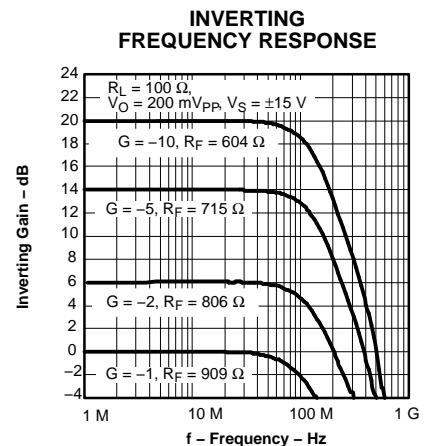

Figure 3.

TYPICAL CHARACTERISTICS ( $\pm 15$  V) (continued)

0.1 dB FLATNESS

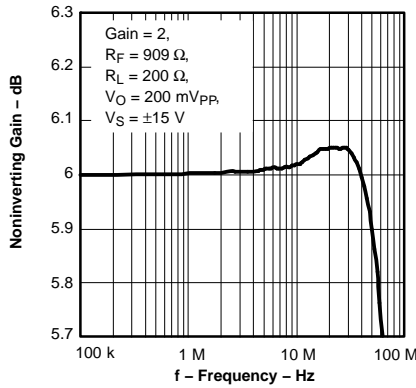

Figure 4.

NONINVERTING  
FREQUENCY RESPONSE

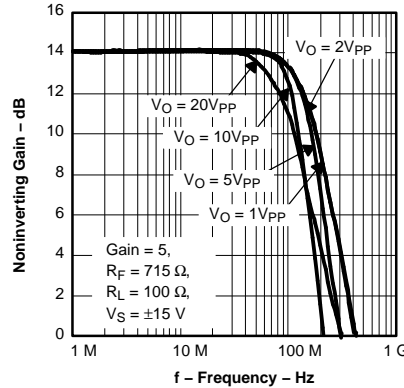

Figure 5.

INVERTING  
FREQUENCY RESPONSE

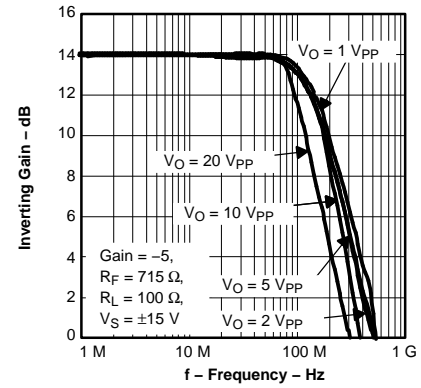

Figure 6.

FREQUENCY RESPONSE  
CAPACITIVE LOAD

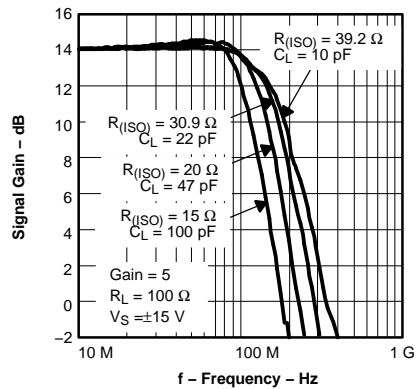

Figure 7.

RECOMMENDED  $R_{ISO}$   
VS  
CAPTIVATE LOAD

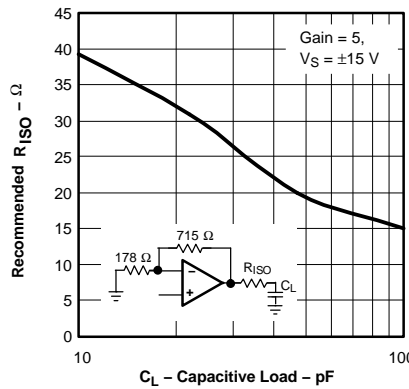

Figure 8.

2ND HARMONIC DISTORTION  
VS  
FREQUENCY

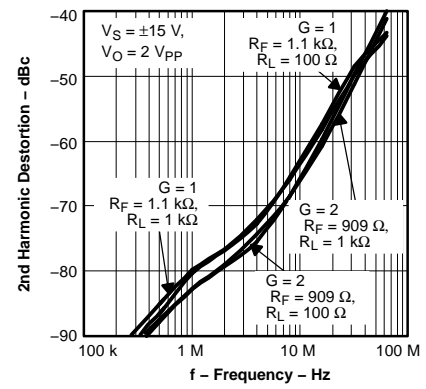

Figure 9.

3RD HARMONIC DISTORTION  
VS  
FREQUENCY

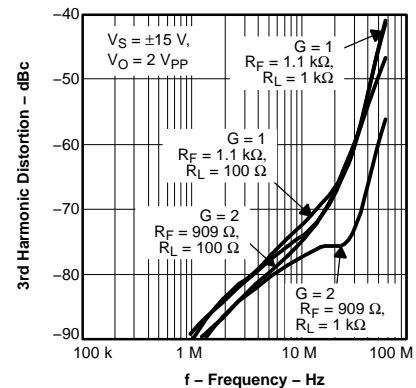

Figure 10.

2ND HARMONIC DISTORTION  
VS  
FREQUENCY

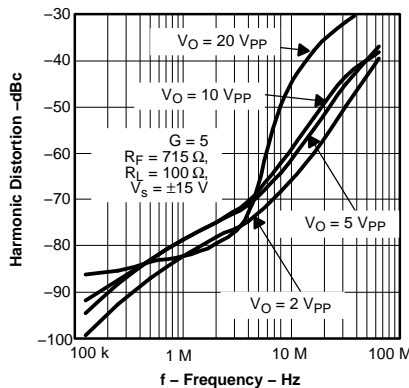

Figure 11.

3RD HARMONIC DISTORTION  
VS  
FREQUENCY

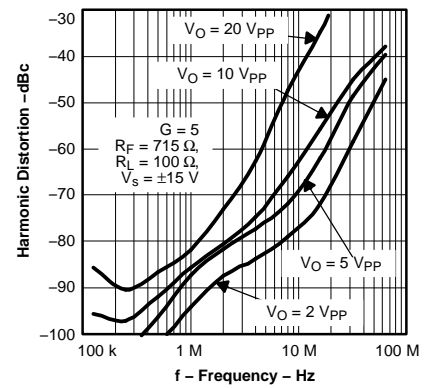

Figure 12.

TYPICAL CHARACTERISTICS ( $\pm 15$  V) (continued)

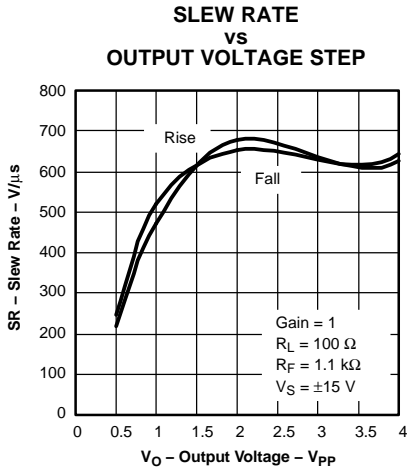

Figure 13.

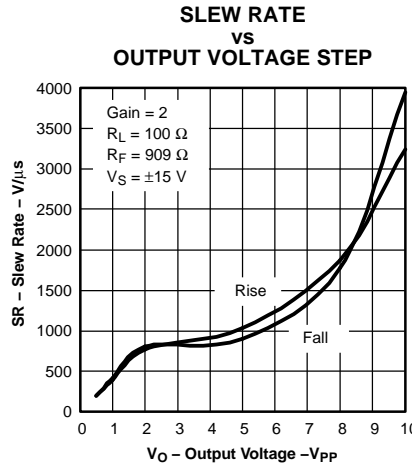

Figure 14.

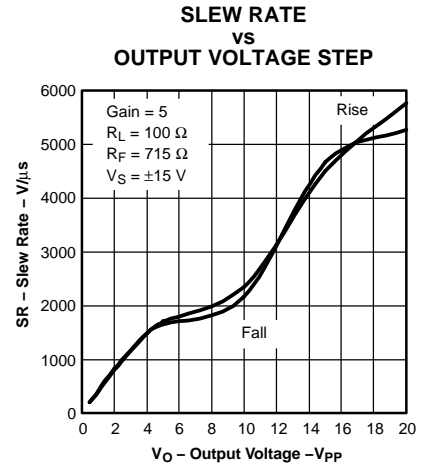

Figure 15.

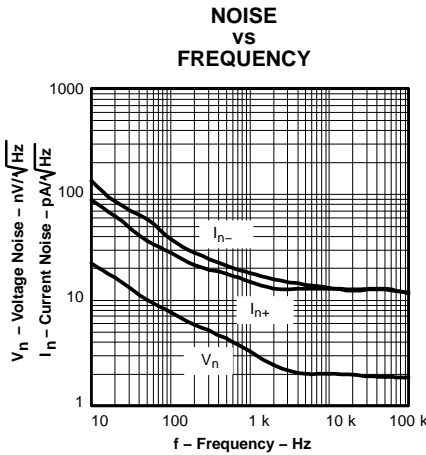

Figure 16.

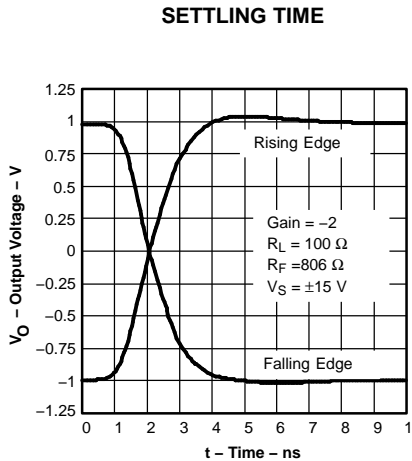

Figure 17.

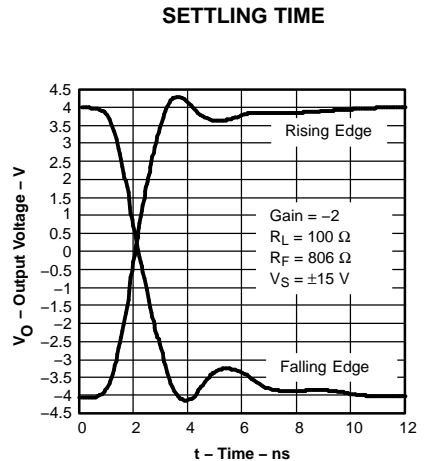

Figure 18.

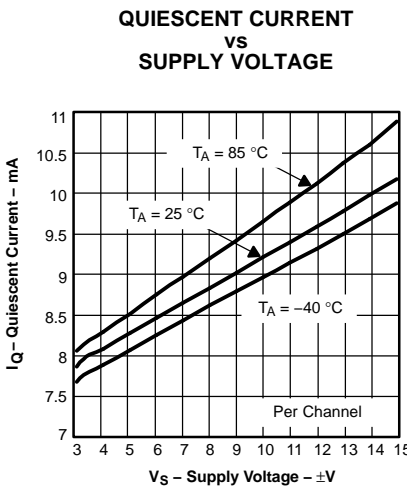

Figure 19.

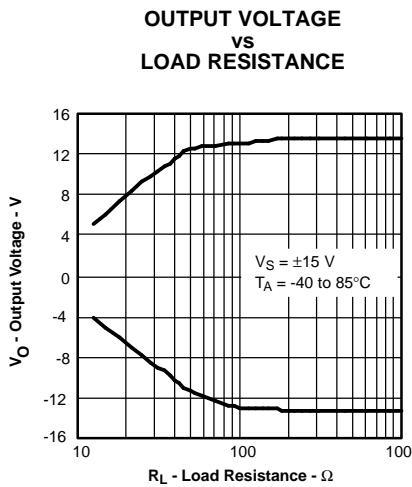

Figure 20.

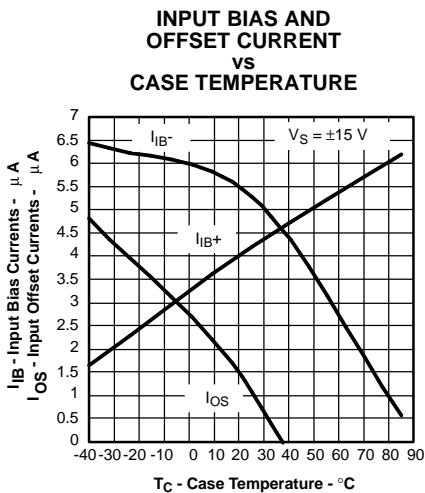

Figure 21.

**TYPICAL CHARACTERISTICS ( $\pm 15$  V) (continued)**

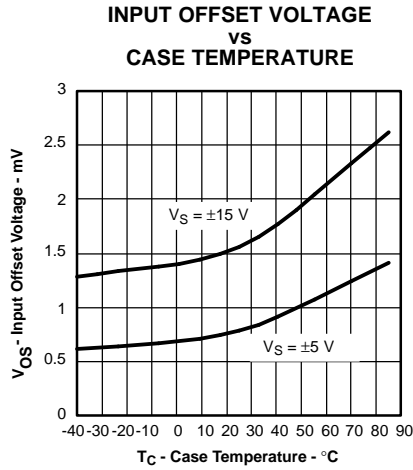

Figure 22.

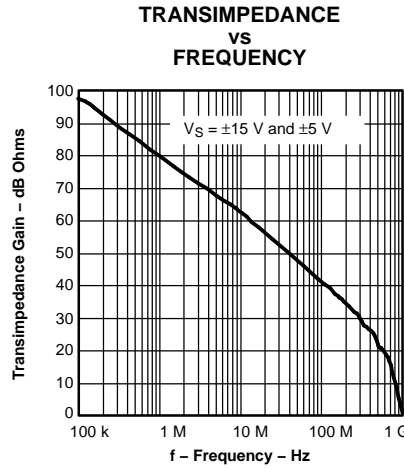

Figure 23.

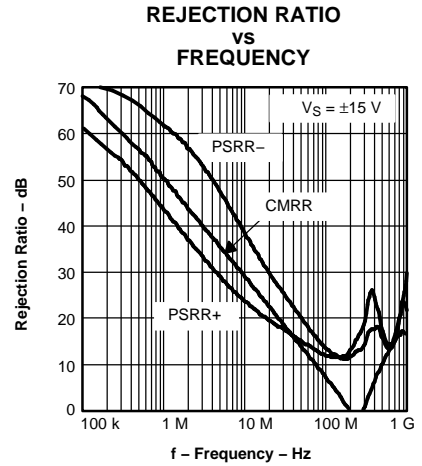

Figure 24.

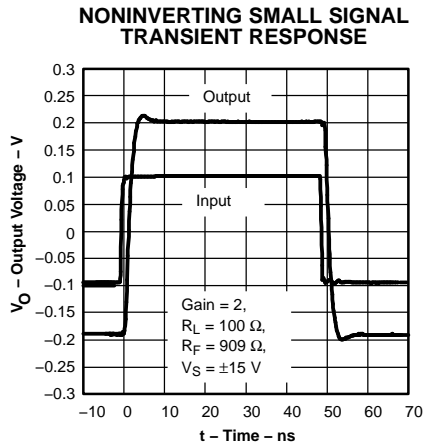

Figure 25.

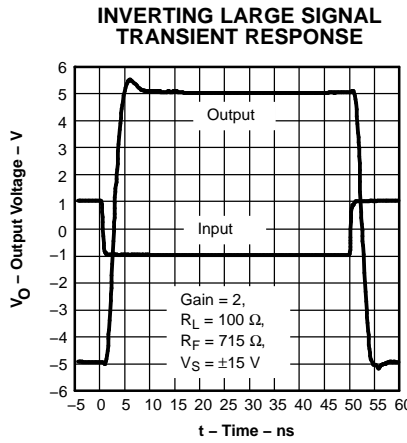

Figure 26.

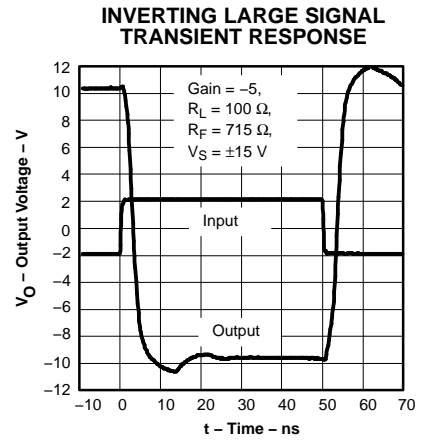

Figure 27.

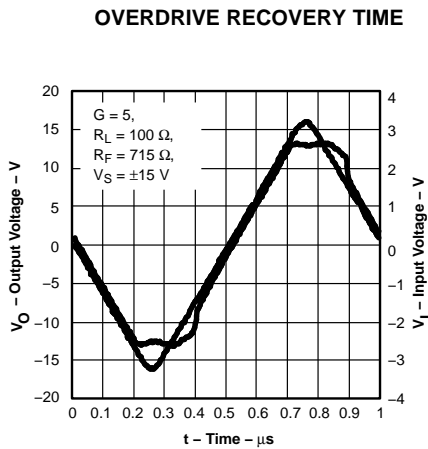

Figure 28.

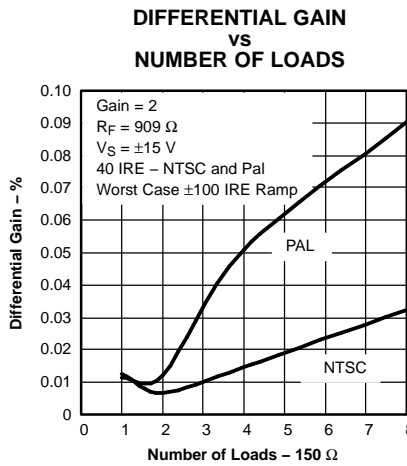

Figure 29.

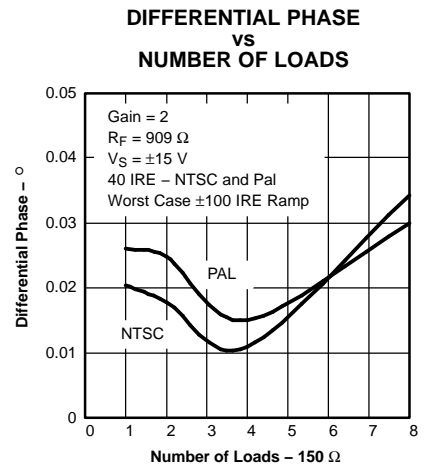

Figure 30.

TYPICAL CHARACTERISTICS ( $\pm 15$  V) (continued)

CLOSED-LOOP OUTPUT IMPEDANCE VS FREQUENCY

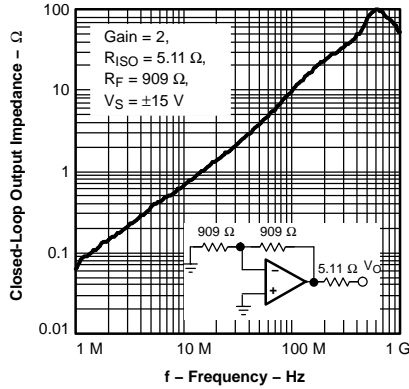

Figure 31.

CROSSTALK VS FREQUENCY

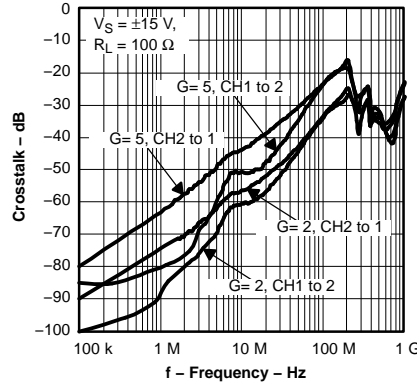

Figure 32.

POWER-DOWN QUIESCENT CURRENT VS SUPPLY VOLTAGE

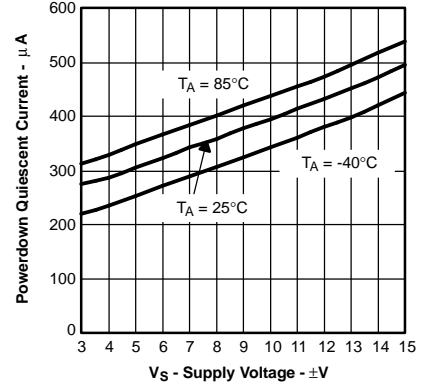

Figure 33.

TURNON AND TURNOFF TIME DELAY

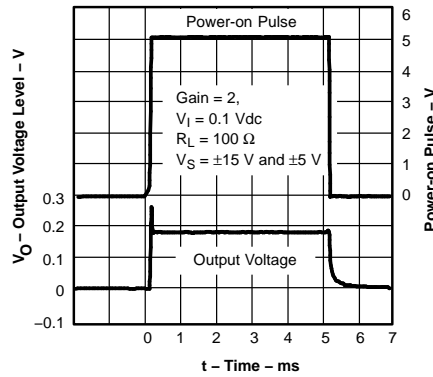

Figure 34.

TYPICAL CHARACTERISTICS ( $\pm 5$  V)

NONINVERTING FREQUENCY RESPONSE

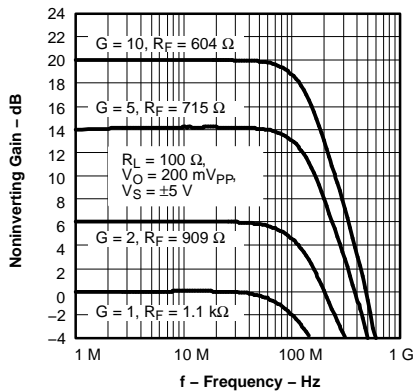

Figure 35.

INVERTING FREQUENCY RESPONSE

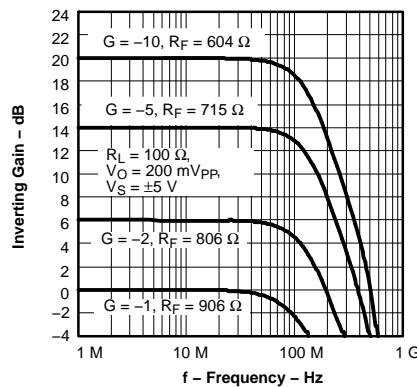

Figure 36.

0.1 dB FLATNESS

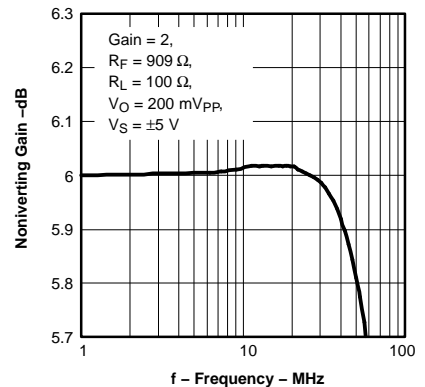

Figure 37.

TYPICAL CHARACTERISTICS ( $\pm 5$  V) (continued)

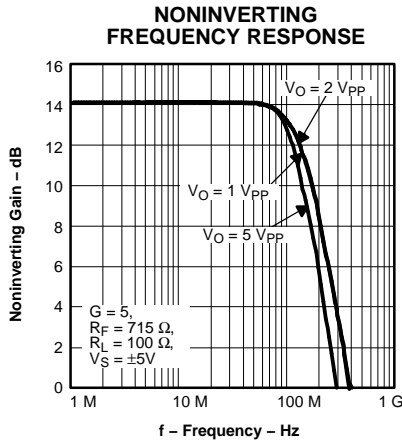

Figure 38.

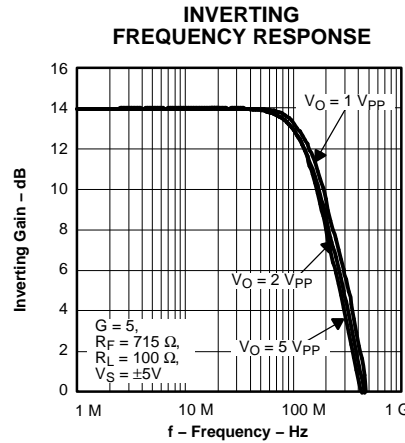

Figure 39.

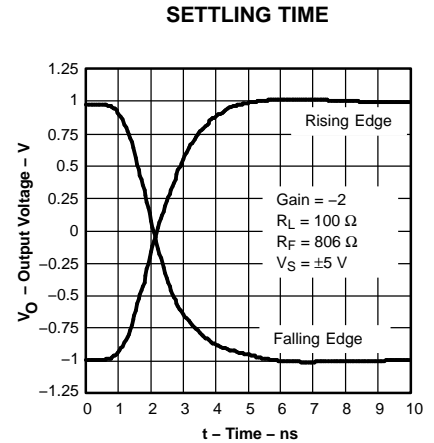

Figure 40.

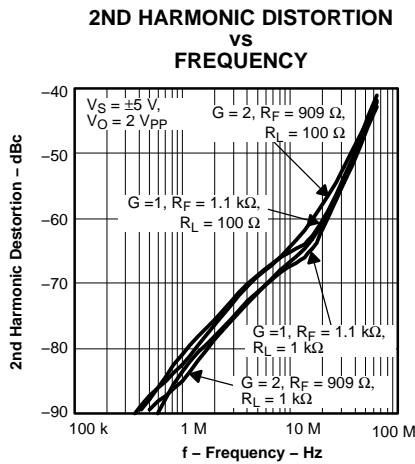

Figure 41.

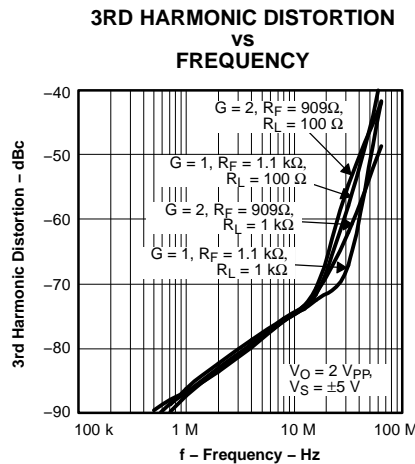

Figure 42.

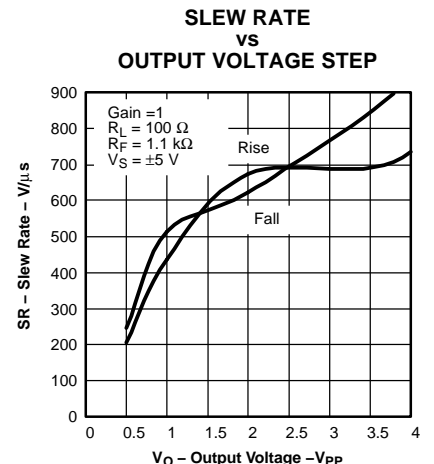

Figure 43.

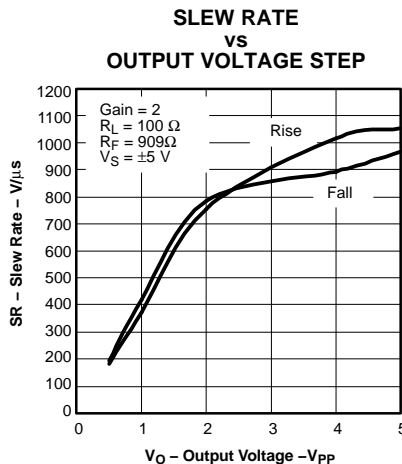

Figure 44.

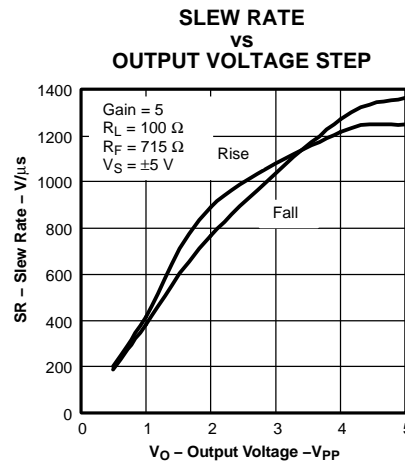

Figure 45.

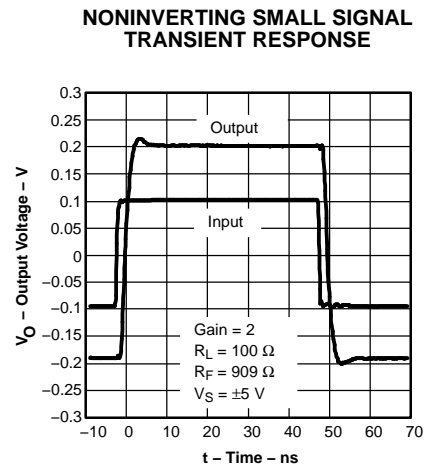

Figure 46.

TYPICAL CHARACTERISTICS ( $\pm 5$  V) (continued)

OUTPUT VOLTAGE  
VS  
LOAD RESISTANCE

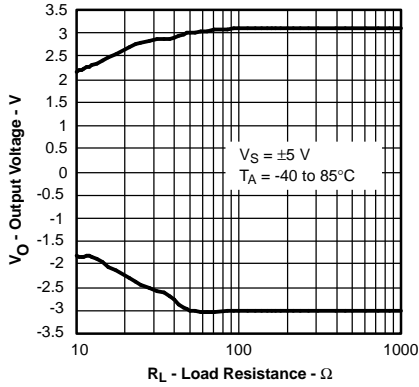

Figure 47.

INPUT BIAS AND  
OFFSET CURRENT  
VS  
CASE TEMPERATURE

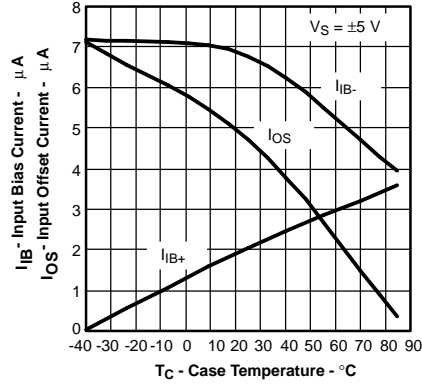

Figure 48.

OVERDRIVE RECOVERY TIME

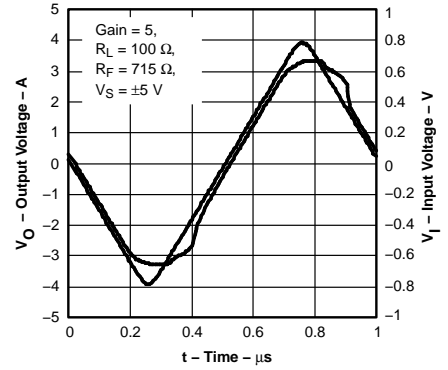

Figure 49.

REJECTION RATIO  
VS  
FREQUENCY

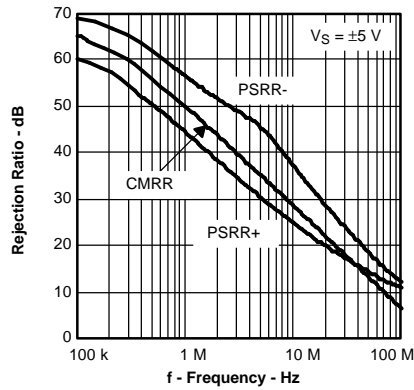

Figure 50.

CROSSTALK  
VS  
FREQUENCY

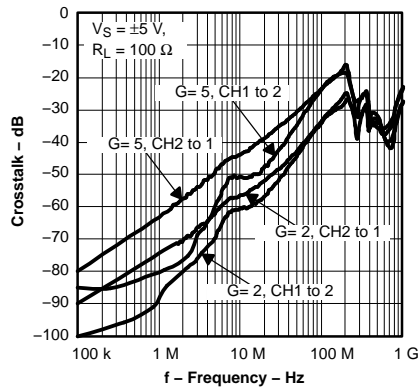

Figure 51.

## APPLICATION INFORMATION

### WIDEBAND, NONINVERTING OPERATION

The THS3092/6 are unity gain stable 135-MHz current-feedback operational amplifiers, designed to operate from a  $\pm 5$ -V to  $\pm 15$ -V power supply.

Figure 52 shows the THS3092 in a noninverting gain of 2-V/V configuration typically used to generate the performance curves. Most of the curves were characterized using signal sources with 50- $\Omega$  source impedance, and with measurement equipment presenting a 50- $\Omega$  load impedance.

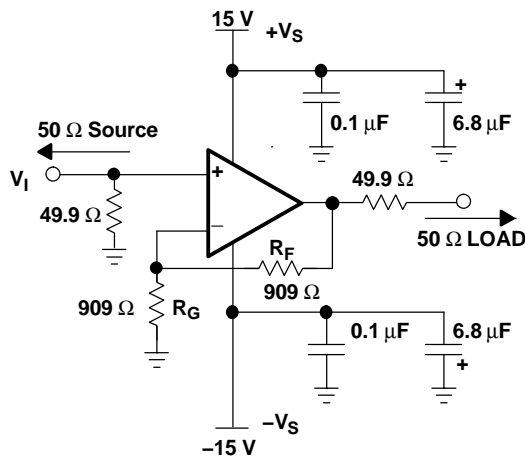

Figure 52. Wideband, Noninverting Gain Configuration

the feedback resistor  $R_F$  for maximum performance and stability. Table 1 shows the optimal gain setting resistors  $R_F$  and  $R_G$  at different gains to give maximum bandwidth with minimal peaking in the frequency response. Higher bandwidths can be achieved, at the expense of added peaking in the frequency response, by using even lower values for  $R_F$ . Conversely, increasing  $R_F$  decreases the bandwidth, but stability is improved.

Table 1. Recommended Resistor Values for Optimum Frequency Response

THS3092 and THS3096 $R_F$ and $R_G$ values for minimal peaking with $R_L = 100 \Omega$			
GAIN (V/V)	SUPPLY VOLTAGE (V)	$R_G$ ( $\Omega$ )	$R_F$ ( $\Omega$ )
1	$\pm 15$	--	1.1 k
	$\pm 5$	--	1.1 k
2	$\pm 15$	909	909
	$\pm 5$	909	909
5	$\pm 15$	178	715
	$\pm 5$	178	715
10	$\pm 15$	66.5	604
	$\pm 5$	66.5	604
-1	$\pm 15$ and $\pm 5$	909	909
-2	$\pm 15$ and $\pm 5$	402	806
-5	$\pm 15$ and $\pm 5$	143	715
-10	$\pm 15$ and $\pm 5$	60.4	604

Current-feedback amplifiers are highly dependent on

## WIDEBAND, INVERTING OPERATION

Figure 53 shows the THS3092 in a typical inverting gain configuration where the input and output impedances and signal gain from Figure 52 are retained in an inverting circuit configuration.

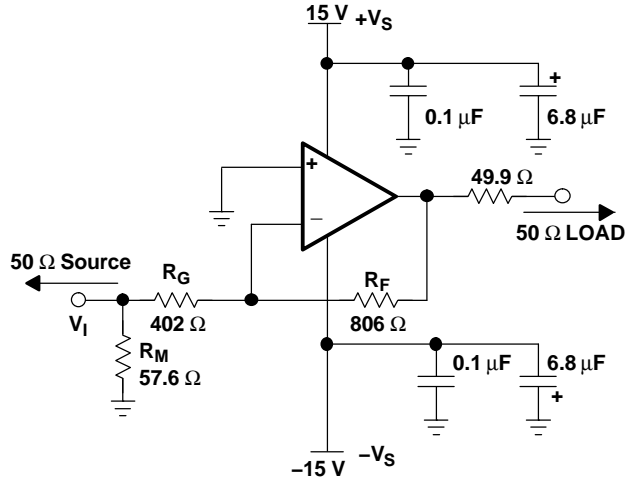

Figure 53. Wideband, Inverting Gain Configuration

## SINGLE SUPPLY OPERATION

The THS3092/6 have the capability to operate from a single supply voltage ranging from 10 V to 30 V. When operating from a single power supply, biasing the input and output at mid-supply allows for the maximum output voltage swing. The circuits shown in Figure 54 shows inverting and noninverting amplifiers configured for single supply operations.

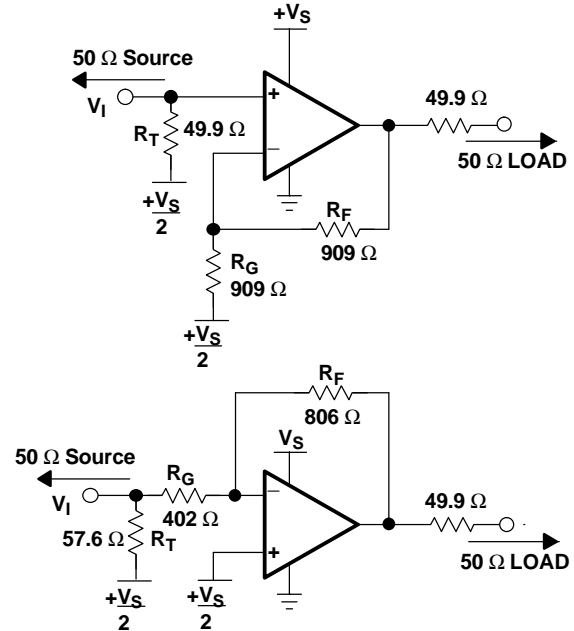

Figure 54. DC-Coupled, Single-Supply Operation

## VDSL Driver Circuit

The THS3092 and THS3096 have the ability to drive over 200 mA of current with very high voltage swings. Using these amplifiers coupled with the very high slew rate, low distortion, and low noise required in VDSL applications, makes for a perfect match. In VDSL systems where the receive signal is critical, the use of a low transformer ratio is necessary. With this low ratio, the output swing required from the line driver amplifier must increase, especially when driving the VDSL's full 14.5-dBm power onto the line. The line driver's low distortion and noise is critical for the VDSL as the receive bands are intertwined with the transmit frequency bands up to the 12-MHz VDSL limit.

Figure 55 shows a traditional hybrid connection approach for achieving the 14.5-dBm line power utilizing a 1:1 transformer. Looking at the input to the amplifiers shows a low-pass filter consisting of two separate capacitors to ground. There is an argument that since the signal coming out of the DAC is fully-differential then a single capacitor (10 pF in this case) is perfectly acceptable. The problem with this idea is that many DACs have common-mode energy due to images around the sampling frequency which must be filtered before reaching the amplifier. An amplifier simply amplifies its input—including the DAC's images at high frequencies—and pass it through to the transformer and ultimately to the line, possibly causing the system to fail EMC compliance. A single capacitor does *not* remove these

common-mode images, it only removes the differential signal images. However, two separate filter capacitors filter both the common-mode signals and the differential-mode signals. Be sure to place the ground connection point of the capacitors next to each other, and then tie a single ground point at the middle of this trace.

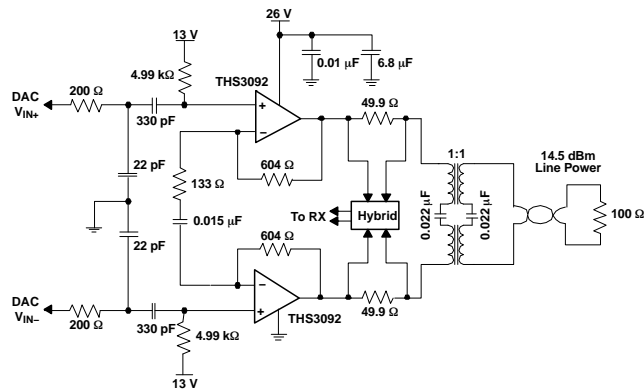

Figure 55.

Additionally, level shifting must be done to center the common-mode voltage appearing at the amplifier's noninverting input to optimally the midpoint of the power supply. As a side benefit of the ac-coupling/level shifter, a simple high pass filter is formed. This is generally a good idea for VDSL systems where the transmit band is typically above 1 MHz, but can be as low as 25 kHz.

One of the concerns about any DSL line driver is the power dissipation. One of the most common ways to reduce power is by using active termination, aka synthesized impedance. Refer to TI Application Note SLOA100 for more information on active termination. The drawback to active termination is the received signal is reduced by the same synthesis factor utilized in the system. Due to the very high attenuation of the line at up to 12 MHz, the receive signal can be severely diminished. Thus, the use of active termination should be kept to modest levels at best. Figure 56 shows an example of utilizing a simple active termination scheme with a synthesis factor of 2 to achieve the same line power, but with a reduced power supply voltage that ultimately saves power in the system.

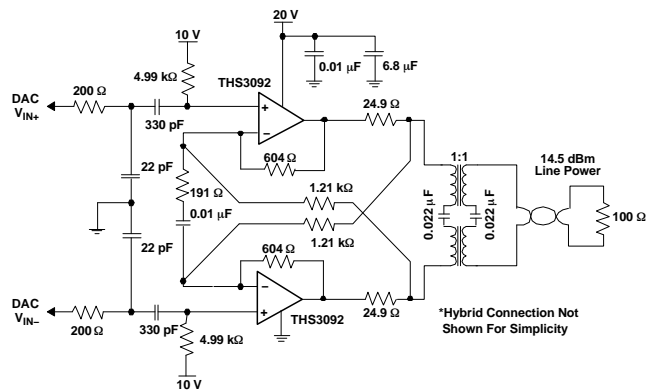

Figure 56.

### Video Distribution

The wide bandwidth, high slew rate, and high output drive current of the THS3092/6 matches the demands for video distribution for delivering video signals down multiple cables. To ensure high signal quality with minimal degradation of performance, a 0.1-dB gain flatness should be at least 7x the passband frequency to minimize group delay variations from the amplifier. A high slew rate minimizes distortion of the video signal, and supports component video and RGB video signals that require fast transition times and fast settling times for high signal quality.

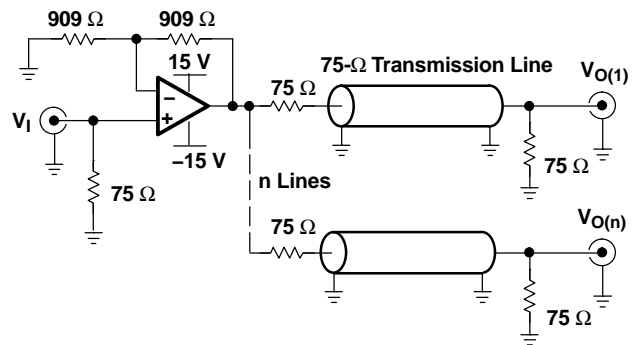

Figure 57. Video Distribution Amplifier Application

### Driving Capacitive Loads

Applications such as FET line drivers can be highly capacitive and cause stability problems for high-speed amplifiers.

Figure 58 through Figure 63 show recommended methods for driving capacitive loads. The basic idea is to use a resistor or ferrite chip to isolate the phase shift at high frequency caused by the capacitive load from the amplifier's feedback path. See Figure 58 for recommended resistor values versus capacitive load.

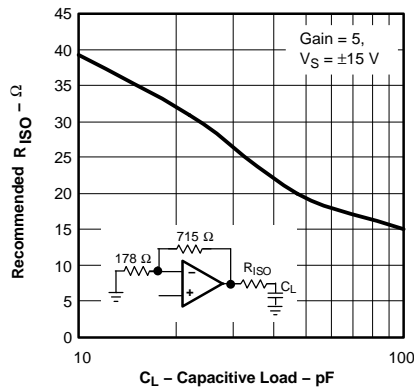

Figure 58. Recommended  $R_{ISO}$  vs Capacitive Load

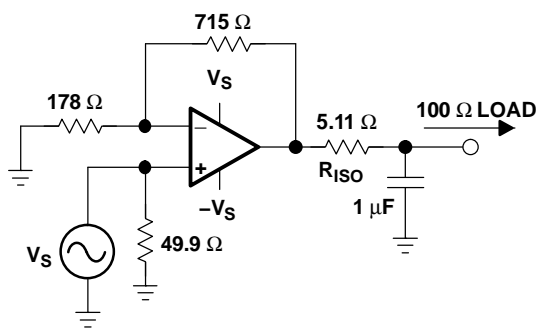

Figure 59.

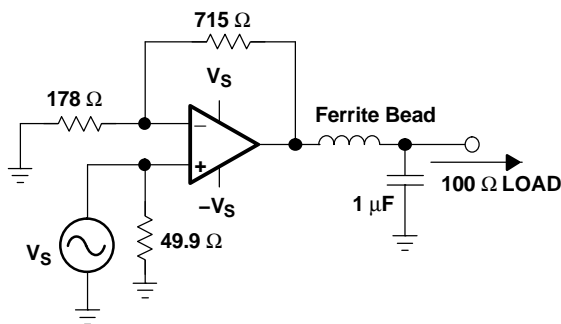

Figure 60.

Placing a small series resistor,  $R_{ISO}$ , between the amplifier's output and the capacitive load, as shown in Figure 59, is an easy way of isolating the load capacitance.

Using a ferrite chip in place of  $R_{ISO}$ , as shown in Figure 60, is another approach of isolating the output of the amplifier. The ferrite's impedance characteristic versus frequency is useful to maintain the low frequency load independence of the amplifier while isolating the phase shift caused by the capacitance at high frequency. Use a ferrite with similar impedance to  $R_{ISO}$ , 20  $\Omega$  - 50  $\Omega$ , at 100 MHz and low impedance at dc.

Figure 61 shows another method used to maintain the low frequency load independence of the amplifier while isolating the phase shift caused by the capacitance at high frequency. At low frequency, feedback is mainly from the load side of  $R_{ISO}$ . At high frequency, the feedback is mainly via the 27-pF capacitor. The resistor  $R_{IN}$  in series with the negative input is used to stabilize the amplifier and should be equal to the recommended value of  $R_F$  at unity gain. Replacing  $R_{IN}$  with a ferrite of similar impedance at about 100 MHz as shown in Figure 62 gives similar results with reduced dc offset and low frequency noise. (See the *ADDITIONAL REFERENCE MATERIAL* section for Expanding the usability of current-feedback amplifiers.)

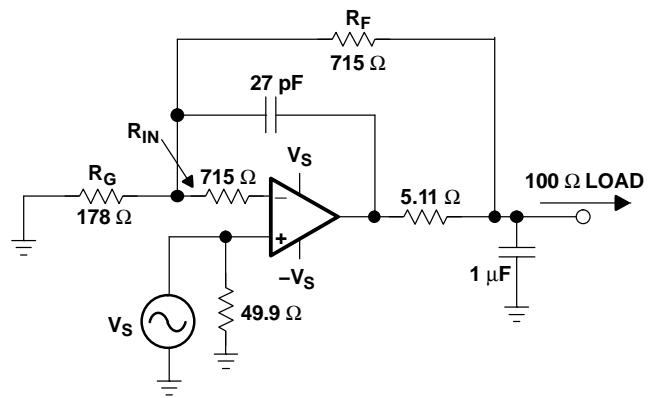

Figure 61.

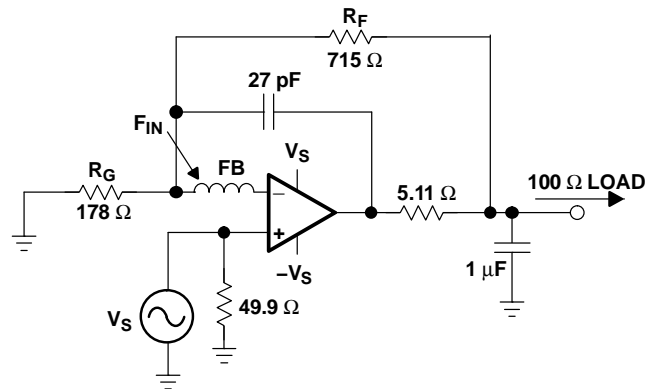

Figure 62.

Figure 63 is shown using two amplifiers in parallel to double the output drive current to larger capacitive loads. This technique is used when more output current is needed to charge and discharge the load faster like when driving large FET transistors.

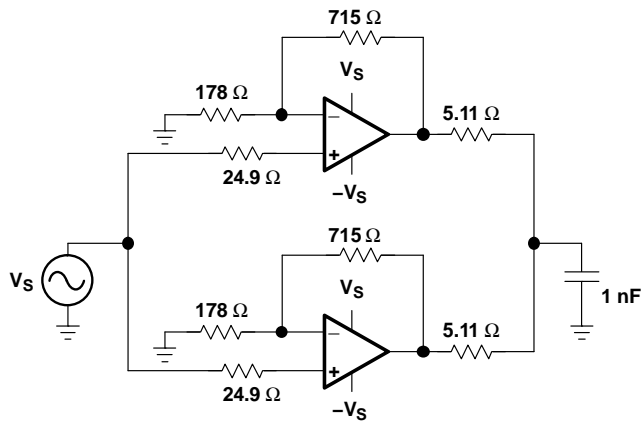

Figure 63.

Figure 64 shows a push-pull FET driver circuit typical of ultrasound applications with isolation resistors to isolate the gate capacitance from the amplifier.

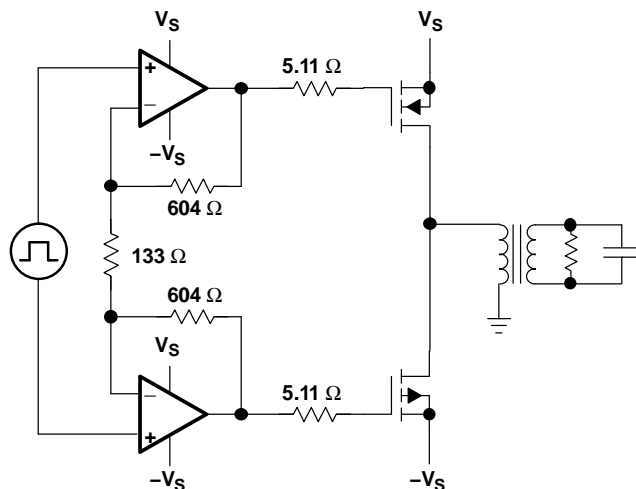

Figure 64. PowerFET Drive Circuit

### SAVING POWER WITH POWER-DOWN FUNCTIONALITY AND SETTING THRESHOLD LEVELS WITH THE REFERENCE PIN

The THS3096 features a power-down pin ( $\overline{PD}$ ) which lowers the quiescent current from 9.5 mA down to 500  $\mu$ A, ideal for reducing system power.

The power-down pin of the amplifier defaults to the positive supply voltage in the absence of an applied voltage, putting the amplifier in the power-on mode of operation. To turn off the amplifier in an effort to conserve power, the power-down pin can be driven towards the negative rail. The threshold voltages for power-on and power-down are relative to the supply

rails and are given in the specification tables. Above the *Enable Threshold Voltage*, the device is on. Below the *Disable Threshold Voltage*, the device is off. Behavior in between these threshold voltages is not specified.

Note that this power-down functionality is just that; the amplifier consumes less power in power-down mode. The power-down mode is not intended to provide a high-impedance output. In other words, the power-down functionality is not intended to allow use as a 3-state bus driver. When in power-down mode, the impedance looking back into the output of the amplifier is dominated by the feedback and gain setting resistors, but the output impedance of the device itself varies depending on the voltage applied to the outputs.

Figure 65 shows the total system output impedance which includes the amplifier output impedance in parallel with the feedback plus gain resistors, which cumulate to 2420  $\Omega$ . Figure 52 shows this circuit configuration for reference.

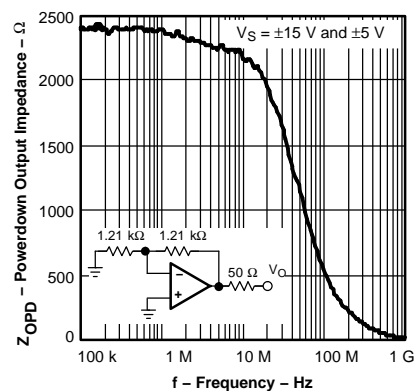

Figure 65. Power-down Output Impedance vs Frequency

As with most current feedback amplifiers, the internal architecture places some limitations on the system when in power-down mode. Most notably is the fact that the amplifier actually turns ON if there is a  $\pm 0.7$  V or greater difference between the two input nodes ( $V+$  and  $V-$ ) of the amplifier. If this difference exceeds  $\pm 0.7$  V, the output of the amplifier creates an output voltage equal to approximately  $[(V+ - V-) - 0.7 \text{ V}] \times \text{Gain}$ . This also implies that if a voltage is applied to the output while in power-down mode, the  $V-$  node voltage is equal to  $V_{O(\text{applied})} \times R_G / (R_F + R_G)$ . For low gain configurations and a large applied voltage at the output, the amplifier may actually turn ON due to the aforementioned behavior.

The time delays associated with turning the device on

and off are specified as the time it takes for the amplifier to reach either 10% or 90% of the final output voltage. The time delays are in the order of microseconds because the amplifier moves in and out of the linear mode of operation in these transitions.

## POWER-DOWN REFERENCE PIN OPERATION

In addition to the power-down pin, the THS3096 features a reference pin (REF) which allows the user to control the enable or disable power-down voltage levels applied to the  $\overline{\text{PD}}$  pin. In most split-supply applications, the reference pin is connected to ground. In either case, the user needs to be aware of voltage-level thresholds that apply to the power-down pin. The tables below show examples and illustrate the relationship between the reference voltage and the power-down thresholds. In the table, the threshold levels are derived by the following equations:

$$\overline{\text{PD}} \leq \text{REF} + 0.8 \text{ V for disable}$$

$$\overline{\text{PD}} \geq \text{REF} + 2.0 \text{ V for enable}$$

where the usable range at the REF pin is  $V_{S-} \leq V_{\text{REF}} \leq (V_{S+} - 4 \text{ V})$ .

The recommended mode of operation is to tie the REF pin to midrail, thus setting the enable/disable thresholds to  $V_{\text{midrail}} + 2 \text{ V}$  and  $V_{\text{midrail}} + 0.8 \text{ V}$  respectively.

**Table 2. Power-Down Threshold Voltage Levels**

SUPPLY VOLTAGE (V)	REFERENCE PIN VOLTAGE (V)	ENABLE LEVEL (V)	DISABLE LEVEL (V)
±15, ±5	0.0	2.0	0.8
±15	2.0	4.0	2.8
±15	-2.0	0.0	-1.2
±5	1.0	3.0	1.8
±5	-1.0	1.0	-0.2
30	15	17	15.8
10	5.0	7.0	5.8

Note that if the REF pin is left unterminated, it will float to the positive rail and will fall outside of the recommended operating range given above  $V_{S-} \leq V_{\text{REF}} \leq (V_{S+} - 4 \text{ V})$ . As a result, it will no longer serve as a reliable reference for the  $\overline{\text{PD}}$  pin, and the enable/disable thresholds given above will no longer apply. If the  $\overline{\text{PD}}$  pin is also left unterminated, it will also float to the positive rail and the device will be enabled. If balanced, split supplies are used ( $\pm V_S$ ) and the REF and  $\overline{\text{PD}}$  pins are grounded, the device will be disabled.

## PRINTED-CIRCUIT BOARD LAYOUT TECHNIQUES FOR OPTIMAL PERFORMANCE

Achieving optimum performance with high frequency amplifier, like the THS3092/6, requires careful attention to board layout parasitic and external component types.

Recommendations that optimize performance include:

- Minimize parasitic capacitance to any ac ground for all of the signal I/O pins. Parasitic capacitance on the output and input pins can cause instability. To reduce unwanted capacitance, a window around the signal I/O pins should be opened in all of the ground and power planes around those pins. Otherwise, ground and power planes should be unbroken elsewhere on the board.
- Minimize the distance ( $< 0.25''$ ) from the power supply pins to high frequency 0.1- $\mu\text{F}$  and 100-pF decoupling capacitors. At the device pins, the ground and power plane layout should not be in close proximity to the signal I/O pins. Avoid narrow power and ground traces to minimize inductance between the pins and the decoupling capacitors. The power supply connections should always be decoupled with these capacitors. Larger (6.8  $\mu\text{F}$  or more) tantalum decoupling capacitors, effective at lower frequency, should also be used on the main supply pins. These may be placed somewhat farther from the device and may be shared among several devices in the same area of the PC board.
- Careful selection and placement of external components preserve the high frequency performance of the THS3092/6. Resistors should be a very low reactance type. Surface-mount resistors work best and allow a tighter overall layout. Again, keep their leads and PC board trace length as short as possible. Never use wirebound type resistors in a high frequency application. Since the output pin and inverting input pins are the most sensitive to parasitic capacitance, always position the feedback and series output resistors, if any, as close as possible to the inverting input pins and output pins. Other network components, such as input termination resistors, should be placed close to the gain-setting resistors. Even with a low parasitic capacitance shunting the external resistors, excessively high resistor values can create significant time constants that can degrade performance. Good axial metal-film or surface-mount resistors have approximately 0.2 pF in shunt with the resistor. For resistor values  $> 2.0 \text{ k}\Omega$ , this parasitic capacitance can add a pole and/or a zero that can effect circuit operation. Keep resistor values as low as possible, consistent with load driving considerations.

- Connections to other wideband devices on the board may be made with short direct traces or through onboard transmission lines. For short connections, consider the trace and the input to the next device as a lumped capacitive load. Relatively wide traces (50 mils to 100 mils) should be used, preferably with ground and power planes opened up around them. Estimate the total capacitive load and determine if isolation resistors on the outputs are necessary. Low parasitic capacitive loads ( $< 4$  pF) may not need an  $R_S$  since the THS3092/6 are nominally compensated to operate with a 2-pF parasitic load. Higher parasitic capacitive loads without an RS are allowed as the signal gain increases (increasing the unloaded phase margin). If a long trace is required, and the 6-dB signal loss intrinsic to a doubly-terminated transmission line is acceptable, implement a matched impedance transmission line using microstrip or stripline techniques (consult an ECL design handbook for microstrip and stripline layout techniques). A  $50\text{-}\Omega$  environment is not necessary onboard, and in fact, a higher impedance environment improves distortion as shown in the distortion versus load plots. With a characteristic board trace impedance based on board material and trace dimensions, a matching series resistor into the trace from the output of the THS3092/6 is used as well as a terminating shunt resistor at the input of the destination device. Remember also that the terminating impedance is the parallel combination of the shunt resistor and the input impedance of the destination device: this total effective impedance should be set to match the trace impedance. If the 6-dB attenuation of a doubly terminated transmission line is unacceptable, a long trace can be series-terminated at the source end only. Treat the trace as a capacitive load in this case. This does not preserve signal integrity as well as a doubly-terminated line. If the input impedance of the destination device is low, there is some signal attenuation due to the voltage divider formed by the series output into the terminating impedance.
- Socketing a high speed part like the THS3092/6 are not recommended. The additional lead length and pin-to-pin capacitance introduced by the socket can create an extremely troublesome parasitic network which can make it almost impossible to achieve a smooth, stable frequency response. Best results are obtained by soldering the THS3092/6 parts directly onto the board.

### PowerPAD™ DESIGN CONSIDERATIONS

The THS3092/6 are available in a thermally-enhanced PowerPAD family of packages. These packages are constructed using a downset

leadframe upon which the die is mounted [see Figure 66(a) and Figure 66(b)]. This arrangement results in the lead frame being exposed as a thermal pad on the underside of the package [see Figure 66(c)]. Because this thermal pad has direct thermal contact with the die, excellent thermal performance can be achieved by providing a good thermal path away from the thermal pad. Note that devices such as the THS3092/6 have no electrical connection between the PowerPAD and the die.

The PowerPAD package allows for both assembly and thermal management in one manufacturing operation. During the surface-mount solder operation (when the leads are being soldered), the thermal pad can also be soldered to a copper area underneath the package. Through the use of thermal paths within this copper area, heat can be conducted away from the package into either a ground plane or other heat dissipating device.

The PowerPAD package represents a breakthrough in combining the small area and ease of assembly of surface mount with the, heretofore, awkward mechanical methods of heatsinking.

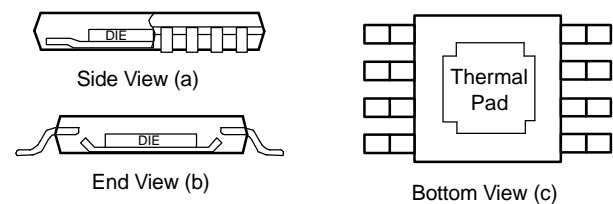

Figure 66. Views of Thermal Enhanced Package

Although there are many ways to properly heatsink the PowerPAD package, the following steps illustrate the recommended approach.

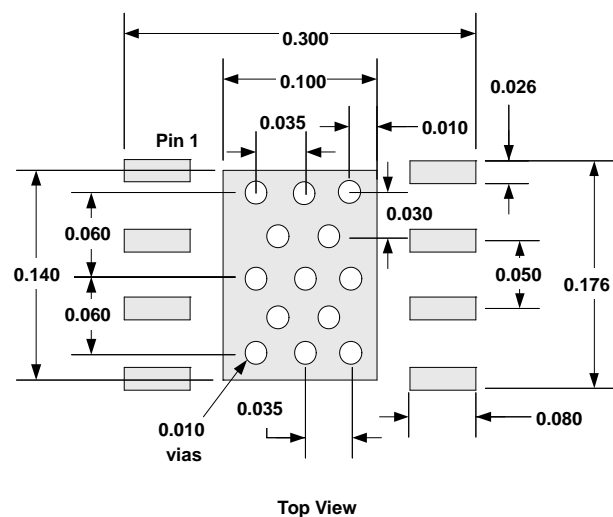

Figure 67. DDA PowerPAD PCB Etch and Via Pattern

## PowerPAD™ LAYOUT CONSIDERATIONS

1. PCB with a top side etch pattern as shown in [Figure 67](#). There should be etch for the leads as well as etch for the thermal pad.
2. Place 13 holes in the area of the thermal pad. These holes should be 10 mils in diameter. Keep them small so that solder wicking through the holes is not a problem during reflow.
3. Additional vias may be placed anywhere along the thermal plane outside of the thermal pad area. This helps dissipate the heat generated by the THS3092/6 IC. These additional vias may be larger than the 10-mil diameter vias directly under the thermal pad. They can be larger because they are not in the thermal pad area to be soldered so that wicking is not a problem.
4. Connect all holes to the internal ground plane. Note that the PowerPAD is electrically isolated from the silicon and all leads. Connecting the PowerPAD to any potential voltage such as  $V_{S-}$  is acceptable as there is no electrical connection to the silicon.
5. When connecting these holes to the ground plane, do not use the typical web or spoke via connection methodology. Web connections have a high thermal resistance connection that is useful for slowing the heat transfer during soldering operations. This makes the soldering of vias that have plane connections easier. In this application, however, low thermal resistance is desired for the most efficient heat transfer. Therefore, the holes under the THS3092/6 PowerPAD package should make their connection to the internal ground plane with a complete connection around the entire circumference of the plated-through hole.
6. The top-side solder mask should leave the terminals of the package and the thermal pad area with its 13 holes exposed. The bottom-side solder mask should cover the 13 holes of the thermal pad area. This prevents solder from being pulled away from the thermal pad area during the reflow process.
7. Apply solder paste to the exposed thermal pad area and all of the IC terminals.
8. With these preparatory steps in place, the IC is simply placed in position and run through the solder reflow operation as any standard surface-mount component. This results in a part that is properly installed.

## POWER DISSIPATION AND THERMAL CONSIDERATIONS

The THS3092/6 incorporates automatic thermal shutoff protection. This protection circuitry shuts down the amplifier if the junction temperature exceeds approximately 160°C. When the junction temperature reduces to approximately 140°C, the amplifier turns on again. But, for maximum performance and reliability, the designer must take care to ensure that the design does not exceed a junction temperature of 125°C. Between 125°C and 150°C, damage does not occur, but the performance of the amplifier begins to degrade and long term reliability suffers. The thermal characteristics of the device are dictated by the package and the PC board. Maximum power dissipation for a given package can be calculated using the following formula.

$$P_{Dmax} = \frac{T_{max} - T_A}{\theta_{JA}}$$

where:

$P_{Dmax}$  is the maximum power dissipation in the amplifier (W).

$T_{max}$  is the absolute maximum junction temperature (°C).

$T_A$  is the ambient temperature (°C).

$$\theta_{JA} = \theta_{JC} + \theta_{CA}$$

$\theta_{JC}$  is the thermal coefficient from the silicon junctions to the case (°C/W).

$\theta_{CA}$  is the thermal coefficient from the case to ambient air (°C/W).

For systems where heat dissipation is more critical, the THS3092 is offered in an 8-pin SOIC (DDA) with PowerPAD package, and the THS3096 is offered in a 14-pin TSSOP (PWP) with PowerPAD package for even better thermal performance. The thermal coefficient for the PowerPAD packages are substantially improved over the traditional SOIC. Maximum power dissipation levels are depicted in the graph for the available packages. The data for the PowerPAD packages assume a board layout that follows the PowerPAD layout guidelines referenced above and detailed in the PowerPAD application note (literature number SLMA002). The following graph also illustrates the effect of not soldering the PowerPAD to a PCB. The thermal impedance increases substantially which may cause serious heat and performance issues. Be sure to always solder the PowerPAD to the PCB for optimum performance.

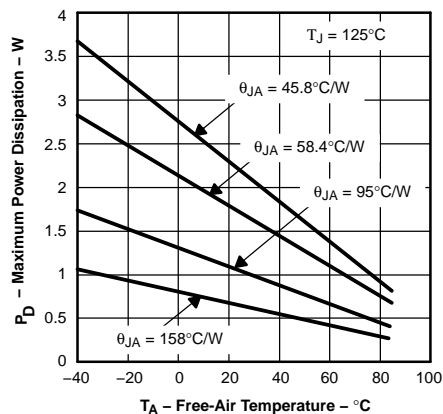

Results are With No Air Flow and PCB Size = 3"x 3"  
 $\theta_{JA} = 45.8^{\circ}\text{C/W}$  for 8-Pin SOIC w/PowerPAD (DDA)  
 $\theta_{JA} = 58.4^{\circ}\text{C/W}$  for 8-Pin MSOP w/PowerPAD (DGN)  
 $\theta_{JA} = 95^{\circ}\text{C/W}$  for 8-Pin SOIC High-K Test PCB (D)  
 $\theta_{JA} = 158^{\circ}\text{C/W}$  for 8-Pin MSOP w/PowerPAD w/o Solder

**Figure 68. Maximum Power Distribution vs Ambient Temperature**

When determining whether or not the device satisfies the maximum power dissipation requirement, it is important to not only consider quiescent power dissipation, but also dynamic power dissipation. Often times, this is difficult to quantify because the signal pattern is inconsistent, but an estimate of the RMS power dissipation can provide visibility into a possible problem.

## DESIGN TOOLS

### Evaluation Fixtures, Spice Models, and Application Support

Texas Instruments is committed to providing its customers with the highest quality of applications support. To support this goal an evaluation board has been developed for the THS3092/6 operational amplifier. The board is easy to use, allowing for straightforward evaluation of the device. The evaluation board can be ordered through the Texas Instruments web site, [www.ti.com](http://www.ti.com), or through your local Texas Instruments sales representative.

Computer simulation of circuit performance using SPICE is often useful when analyzing the performance of analog circuits and systems. This is particularly true for video and RF-amplifier circuits where parasitic capacitance and inductance can have a major effect on circuit performance. A SPICE model for the THS3092/6 is available through either the Texas Instruments web site ([www.ti.com](http://www.ti.com)) or as one model on a disk from the Texas Instruments Product Information Center (1-800-548-6132). The PIC is also available for design assistance and detailed product information at this number. These models do a good job of predicting small-signal ac and transient performance under a wide variety of operating conditions. They are not intended to model the distortion characteristics of the amplifier, nor do they attempt to distinguish between the package types in their small-signal ac performance. Detailed information about what is and is not modeled is contained in the model file itself.

**THS3092 EVM**

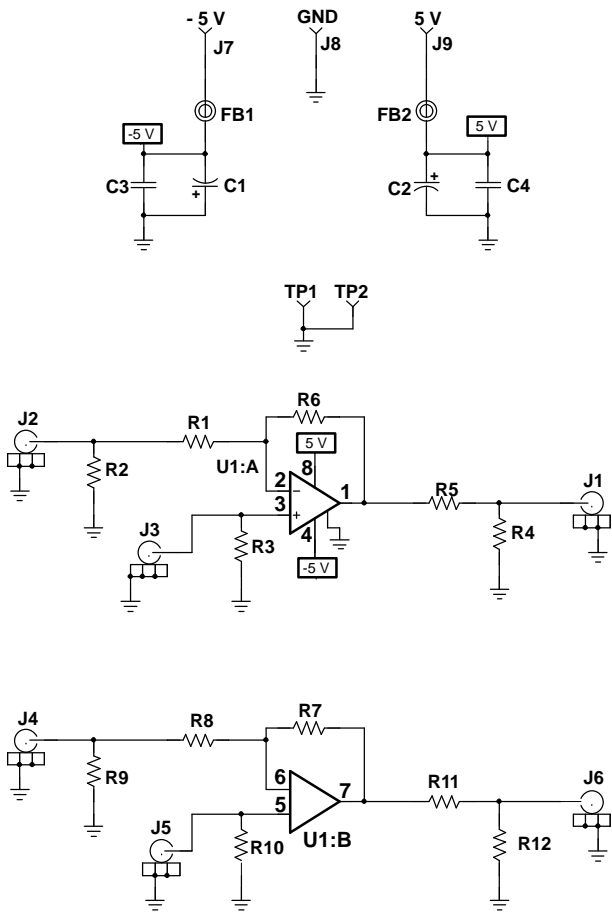

**Figure 69. THS3092 EVM Schematic**

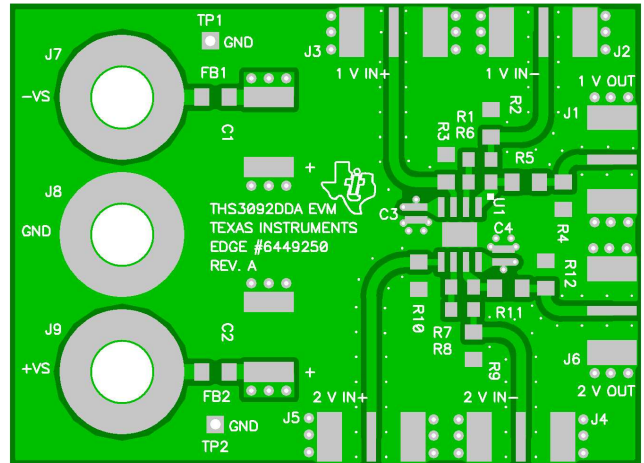

**Figure 70. THS3092 EVM Board Layout (Top Layer)**

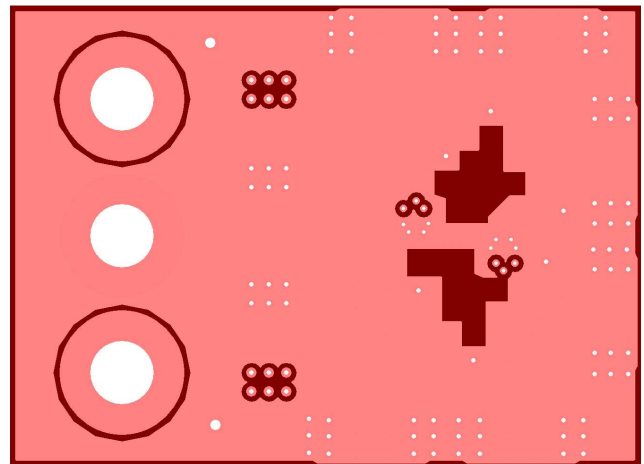

**Figure 71. THS3092 EVM Board Layout (Ground Plane)**

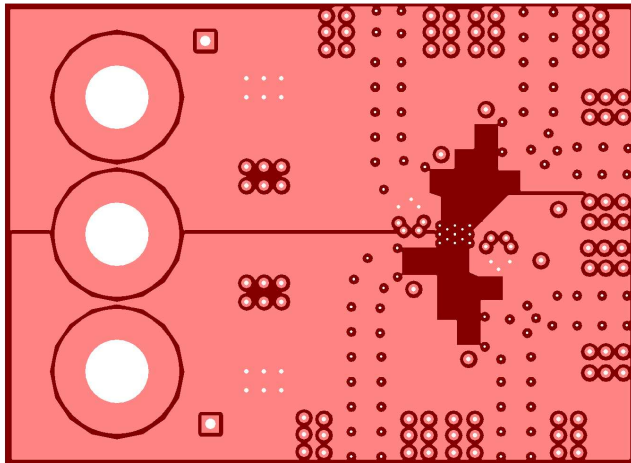

Figure 72. THS3092 EVM Board Layout (Power Plane)

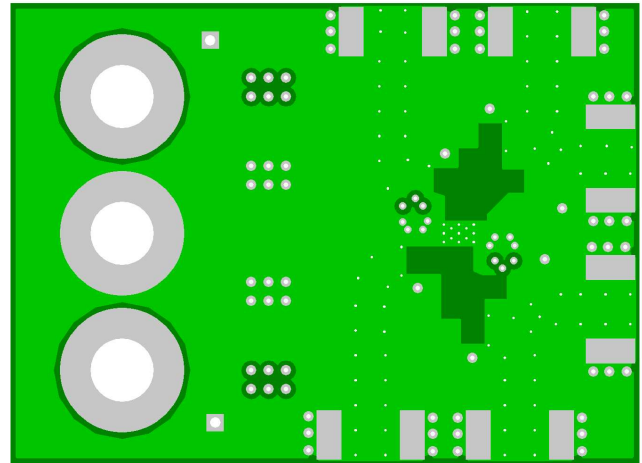

Figure 73. THS3092 EVM Board Layout (Bottom Layer)

Table 3. THS3092 EVM Bill of Materials

THS3092DGN EVM					
ITEM	DESCRIPTION	SMD SIZE	REFERENCE DESIGNATOR	PCB QTY	MANUFACTURER'S PART NUMBER <sup>(1)</sup>
1	Bead, Ferrite, 3 A, 80 Ω	1206	FB1, FB2	2	(Steward) HI1206N800R-00
2	Cap. 22 μF, Tanatalum, 35 V, 10%	D	C1, C2	2	(AVX) TAJD685K035R
3	Cap. 0.1 μF, Ceramic, X7R, 16 V	0805	C3, C4	2	(AVX) 08055C104KAT2A
4	Resistor, 178 Ω, 1/8 W, 1%	0805	R1, R8	2	(KOA) RK73H2ALTD1780F
5	Resistor, 715 Ω, 1/8 W, 1%	0805	R6, R7	2	(KOA) RK73H2ALTD7150F
6	Open	1206	R4, R12	2	
7	Resistor, 0 Ω, 1/4 W, 1%	1206	R2, R9	2	(KOA) RK73Z2BLTD
8	Resistor, 49.9 Ω, 1/4 W, 1%	1206	R1, R5, R10, R11	4	(KOA) RK73H2BLTD49R9F
9	Connector, edge, SMA PCB jack		J1, J2, J3, J4, J5, J6	6	(Johnson) 142-0701-801
10	Jack, banana, 0.25" dia. hole		J7, J8, J9	3	(SPC) 813
11	Test point, black		TP1, TP2	2	(Keystone) 5001
12	IC, THS3092		U1	1	(TI) THS3092DDA
13	Board, printed-circuit			1	(TI) EDGE # 6446250 Rev. A

(1) The manufacturer's part numbers were used for test purposes only.

**THS3096 EVM**

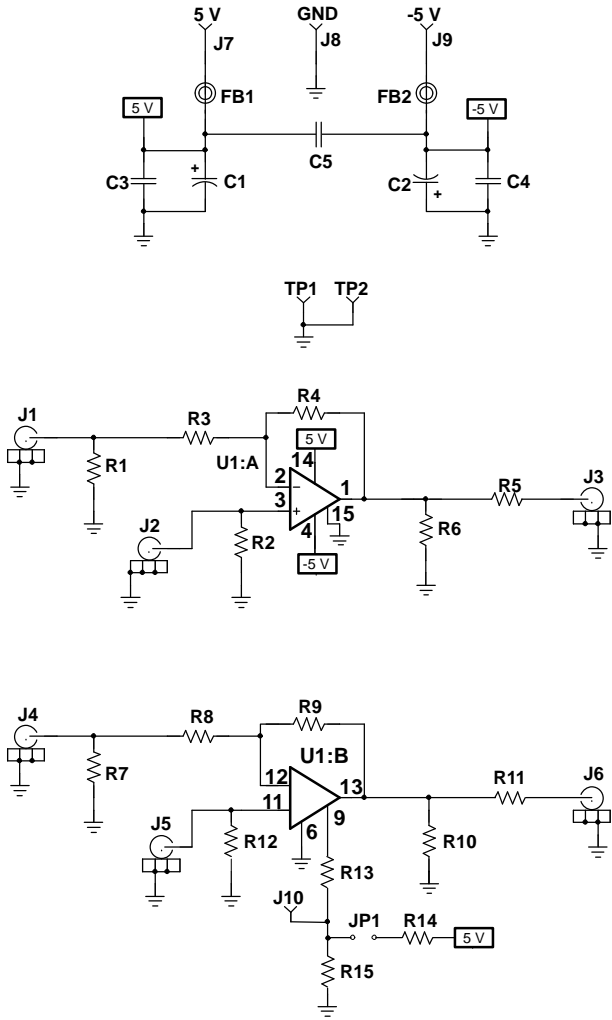

**Figure 74. THS3096 EVM Schematic**

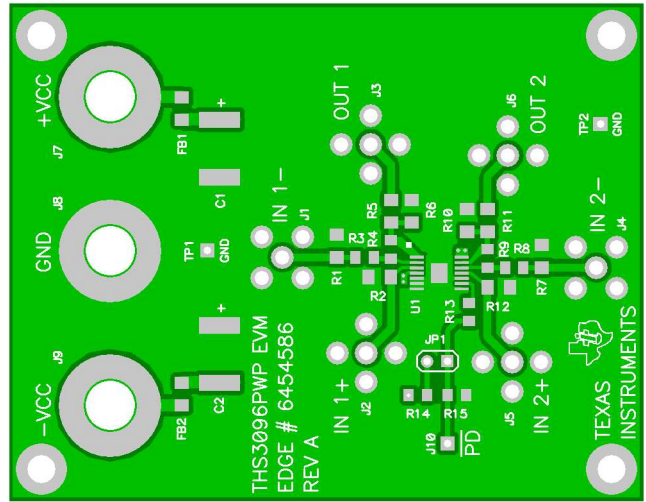

**Figure 75. THS3096 EVM Board Layout (Top Layer)**

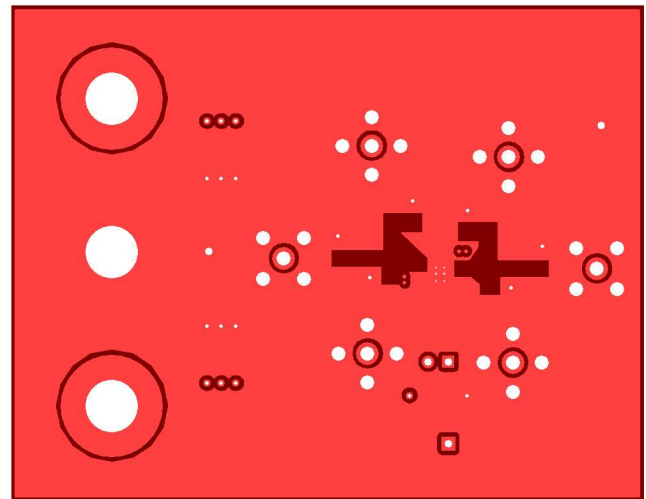

**Figure 76. THS3096 EVM Board Layout (Ground Plane)**

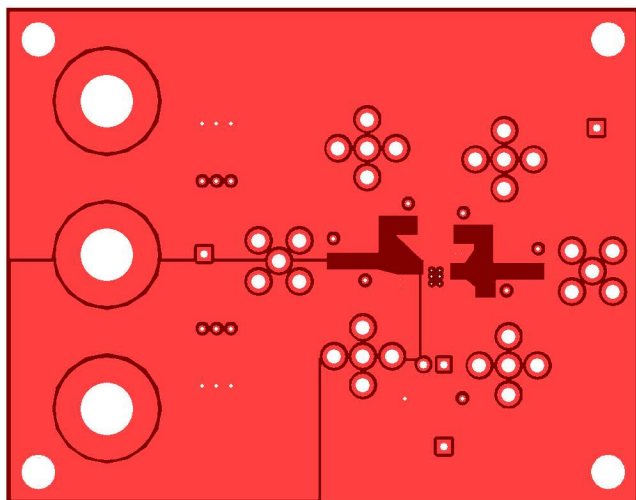

Figure 77. THS3096 EVM Board Layout (Power Plane)

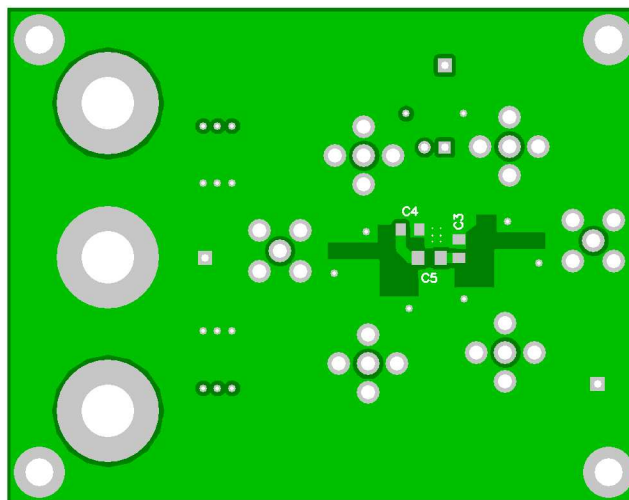

Figure 78. THS3096 EVM Board Layout (Bottom Layer)

Table 4. THS3096 EVM Bill of Materials

THS3096PWP EVM					
ITEM	DESCRIPTION	SMD SIZE	REFERENCE DESIGNATOR	PCB QTY	MANUFACTURER'S PART NUMBER
1	Bead, Ferrite, 3 A, 80 Ω	1206	FB1, FB2	2	(Steward) HI1206N800R-00
2	Cap. 22 μF, Tanatalum, 25 V, 10%	D	C1, C2	2	(AVX) TAJD226K025R
3	Cap. 0.1 μF, Ceramic, X7R, 50 V	0805	C3, C4	2	(AVX) 08055C104KAT2A
4	Cap. 0.1 μF, Ceramic, X7R, 50 V	1206	C5	1	(AVX) 12065C104KAT2A
5	Resistor, 100 Ω, 1/8W, 1%	0805	R13	1	(KOA) RK73H2ALTD1000F
6	Resistor, 178 Ω, 1/8 W, 1%	0805	R3, R8	2	(KOA) RK73H2ALTD1780F
7	Resistor, 715 Ω, 1/8 W, 1%	0805	R4, R9	2	(KOA) RK73H2ALTD7150F
8	Resistor, 20 kΩ, 1/8 W, 1%	0805	R14, R15	2	(KOA) RK73H2ALTD2002F
9	Open	1206	R6, R10	2	
10	Resistor, 0 Ω, 1/4 W, 1%	1206	R1, R7	2	(KOA) RK73Z2BLTD
11	Resistor, 49.9 Ω, 1/4 W, 1%	1206	R2, R5, R11, R12	4	(KOA) RK73H2BLTD49R9F
12	Header, 0.1" ctrs, 0.025" sq. pins	2 pos.	JP1	1	(Sullins) PZC36SAAN
13	Shunts		JP1	1	(Sullins) SSC02SYAN
14	Connector, SMA PCB jack		J1, J2, J3, J4, J5, J6	6	(Amphenol) 901-144-8RFX
15	Jack, banana, 0.25" dia. hole		J7, J8, J9	3	(SPC) 813
16	Test point, red		J10	1	(Keystone) 5000
17	Test point, black		TP1, TP2	2	(Keystone) 5001
18	IC, THS3096		U1	1	(TI) THS3096PWP
19	Board, printed-circuit			1	(TI) EDGE # 6454586 Rev. A

#### **ADDITIONAL REFERENCE MATERIAL**

- PowerPAD Made Easy, application brief (SLMA004)
- PowerPAD Thermally Enhanced Package, technical brief (SLMA002)
- Voltage Feedback vs Current Feedback Amplifiers, (SLVA051)
- Current Feedback Analysis and Compensation (SLOA021)
- Current Feedback Amplifiers: Review, Stability, and Application (SBOA081)
- Effect of Parasitic Capacitance in Op Amp Circuits (SLOA013)
- Expanding the Usability of Current-Feedback Amplifiers, by Randy Stephens, 3Q 2003 Analog Applications Journal [www.ti.com/sc/analogapps](http://www.ti.com/sc/analogapps).
- Active Output Impedance for ADSL Line Drivers (SLOA100)

**PACKAGING INFORMATION**

Orderable Device	Status (1)	Package Type	Package Drawing	Pins	Package Qty	Eco Plan (2)	Lead/Ball Finish (6)	MSL Peak Temp (3)	Op Temp (°C)	Device Marking (4/5)	Samples
THS3092D	ACTIVE	SOIC	D	8	75	Green (RoHS & no Sb/Br)	CU NIPDAU	Level-1-260C-UNLIM	-40 to 85	3092	<a href="#">Samples</a>
THS3092DDA	ACTIVE	SO PowerPAD	DDA	8	75	Green (RoHS & no Sb/Br)	CU SN	Level-1-260C-UNLIM	-40 to 85	3092	<a href="#">Samples</a>
THS3092DDAG3	ACTIVE	SO PowerPAD	DDA	8	75	Green (RoHS & no Sb/Br)	CU SN	Level-1-260C-UNLIM	-40 to 85	3092	<a href="#">Samples</a>
THS3092DDAR	ACTIVE	SO PowerPAD	DDA	8	2500	Green (RoHS & no Sb/Br)	CU SN	Level-1-260C-UNLIM	-40 to 85	3092	<a href="#">Samples</a>
THS3096D	ACTIVE	SOIC	D	14	50	Green (RoHS & no Sb/Br)	CU NIPDAU	Level-1-260C-UNLIM	-40 to 85	THS3096	<a href="#">Samples</a>
THS3096PWP	ACTIVE	HTSSOP	PWP	14	90	Green (RoHS & no Sb/Br)	CU NIPDAU	Level-2-260C-1 YEAR	-40 to 85	THS3096	<a href="#">Samples</a>

(1) The marketing status values are defined as follows:

**ACTIVE:** Product device recommended for new designs.

**LIFEBUY:** TI has announced that the device will be discontinued, and a lifetime-buy period is in effect.

**NRND:** Not recommended for new designs. Device is in production to support existing customers, but TI does not recommend using this part in a new design.

**PREVIEW:** Device has been announced but is not in production. Samples may or may not be available.

**OBSOLETE:** TI has discontinued the production of the device.

(2) **RoHS:** TI defines "RoHS" to mean semiconductor products that are compliant with the current EU RoHS requirements for all 10 RoHS substances, including the requirement that RoHS substance do not exceed 0.1% by weight in homogeneous materials. Where designed to be soldered at high temperatures, "RoHS" products are suitable for use in specified lead-free processes. TI may reference these types of products as "Pb-Free".

**RoHS Exempt:** TI defines "RoHS Exempt" to mean products that contain lead but are compliant with EU RoHS pursuant to a specific EU RoHS exemption.

**Green:** TI defines "Green" to mean the content of Chlorine (Cl) and Bromine (Br) based flame retardants meet JS709B low halogen requirements of <=1000ppm threshold. Antimony trioxide based flame retardants must also meet the <=1000ppm threshold requirement.

(3) MSL, Peak Temp. - The Moisture Sensitivity Level rating according to the JEDEC industry standard classifications, and peak solder temperature.

(4) There may be additional marking, which relates to the logo, the lot trace code information, or the environmental category on the device.

(5) Multiple Device Markings will be inside parentheses. Only one Device Marking contained in parentheses and separated by a "~" will appear on a device. If a line is indented then it is a continuation of the previous line and the two combined represent the entire Device Marking for that device.

<sup>(6)</sup> Lead/Ball Finish - Orderable Devices may have multiple material finish options. Finish options are separated by a vertical ruled line. Lead/Ball Finish values may wrap to two lines if the finish value exceeds the maximum column width.

**Important Information and Disclaimer:**The information provided on this page represents TI's knowledge and belief as of the date that it is provided. TI bases its knowledge and belief on information provided by third parties, and makes no representation or warranty as to the accuracy of such information. Efforts are underway to better integrate information from third parties. TI has taken and continues to take reasonable steps to provide representative and accurate information but may not have conducted destructive testing or chemical analysis on incoming materials and chemicals. TI and TI suppliers consider certain information to be proprietary, and thus CAS numbers and other limited information may not be available for release.

In no event shall TI's liability arising out of such information exceed the total purchase price of the TI part(s) at issue in this document sold by TI to Customer on an annual basis.

## TAPE AND REEL INFORMATION

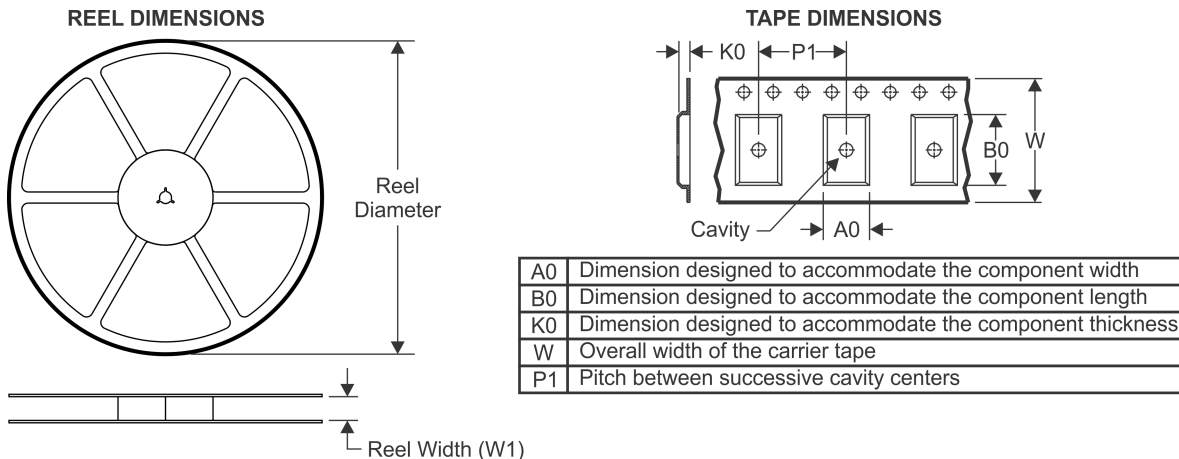

### QUADRANT ASSIGNMENTS FOR PIN 1 ORIENTATION IN TAPE



\*All dimensions are nominal

Device	Package Type	Package Drawing	Pins	SPQ	Reel Diameter (mm)	Reel Width W1 (mm)	A0 (mm)	B0 (mm)	K0 (mm)	P1 (mm)	W (mm)	Pin1 Quadrant
THS3092DDAR	SO Power PAD	DDA	8	2500	330.0	12.4	6.4	5.2	2.1	8.0	12.0	Q1

**TAPE AND REEL BOX DIMENSIONS**

\*All dimensions are nominal

Device	Package Type	Package Drawing	Pins	SPQ	Length (mm)	Width (mm)	Height (mm)
THS3092DDAR	SO PowerPAD	DDA	8	2500	350.0	350.0	43.0



Images above are just a representation of the package family, actual package may vary.  
Refer to the product data sheet for package details.

DDA (R-PDSO-G8)

PowerPAD™ PLASTIC SMALL-OUTLINE



- NOTES:
- All linear dimensions are in millimeters. Dimensioning and tolerancing per ASME Y14.5-1994.
  - This drawing is subject to change without notice.
  - Body dimensions do not include mold flash or protrusion not to exceed 0,15.
  - This package is designed to be soldered to a thermal pad on the board. Refer to Technical Brief, PowerPad Thermally Enhanced Package, Texas Instruments Literature No. SLMA002 for information regarding recommended board layout. This document is available at [www.ti.com](http://www.ti.com) <<http://www.ti.com>>.
  - See the additional figure in the Product Data Sheet for details regarding the exposed thermal pad features and dimensions.
  - This package complies to JEDEC MS-012 variation BA

PowerPAD is a trademark of Texas Instruments.

DDA (R-PDSO-G8)

PowerPAD™ PLASTIC SMALL OUTLINE

**THERMAL INFORMATION**

This PowerPAD™ package incorporates an exposed thermal pad that is designed to be attached to a printed circuit board (PCB). The thermal pad must be soldered directly to the PCB. After soldering, the PCB can be used as a heatsink. In addition, through the use of thermal vias, the thermal pad can be attached directly to the appropriate copper plane shown in the electrical schematic for the device, or alternatively, can be attached to a special heatsink structure designed into the PCB. This design optimizes the heat transfer from the integrated circuit (IC).

For additional information on the PowerPAD package and how to take advantage of its heat dissipating abilities, refer to Technical Brief, PowerPAD Thermally Enhanced Package, Texas Instruments Literature No. SLMA002 and Application Brief, PowerPAD Made Easy, Texas Instruments Literature No. SLMA004. Both documents are available at [www.ti.com](http://www.ti.com).

The exposed thermal pad dimensions for this package are shown in the following illustration.

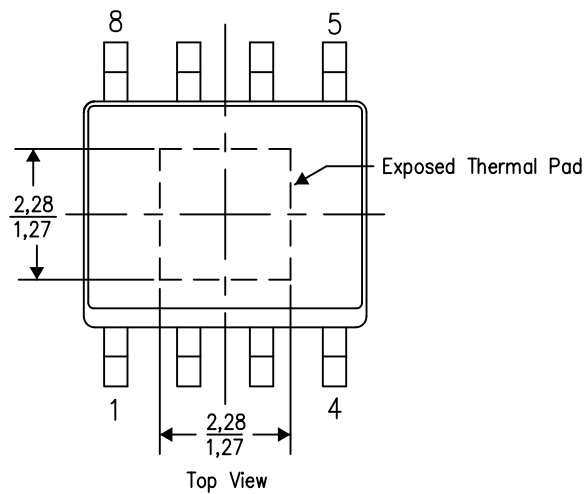

Exposed Thermal Pad Dimensions

4206322-2/L 05/12

NOTE: A. All linear dimensions are in millimeters

PowerPAD is a trademark of Texas Instruments

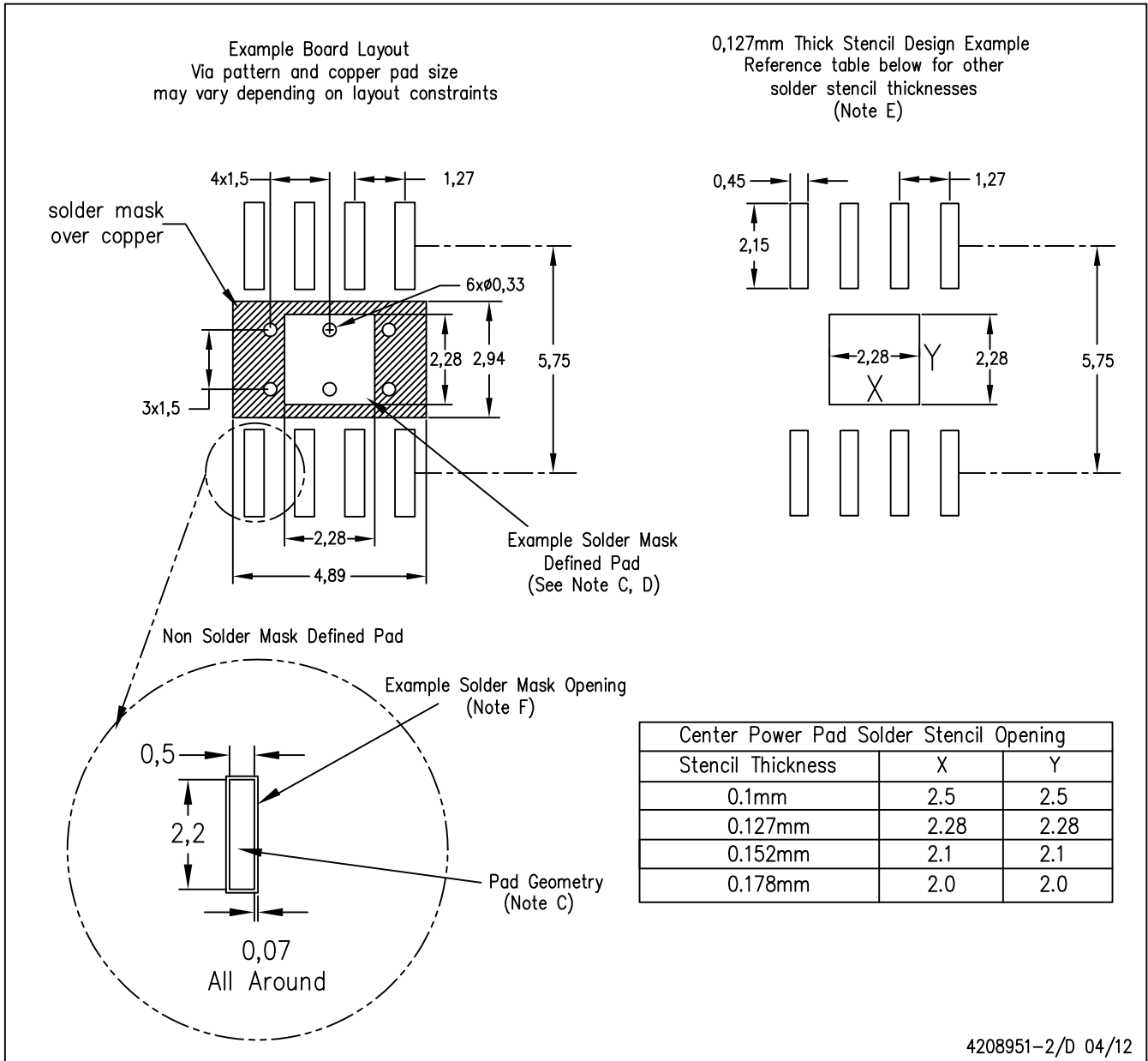

4208951-2/D 04/12



- NOTES:
- A. All linear dimensions are in millimeters.
  - B. This drawing is subject to change without notice.
  - C. Publication IPC-7351 is recommended for alternate designs.
  - D. This package is designed to be soldered to a thermal pad on the board. Refer to Technical Brief, PowerPAD Thermally Enhanced Package, Texas Instruments Literature No. SLMA002, SLMA004, and also the Product Data Sheets for specific thermal information, via requirements, and recommended board layout. These documents are available at [www.ti.com](http://www.ti.com) <<http://www.ti.com>>. Publication IPC-7351 is recommended for alternate designs.
  - E. Laser cutting apertures with trapezoidal walls and also rounding corners will offer better paste release. Customers should contact their board assembly site for stencil design recommendations. Example stencil design based on a 50% volumetric metal load solder paste. Refer to IPC-7525 for other stencil recommendations.
  - F. Customers should contact their board fabrication site for solder mask tolerances between and around signal pads.

PowerPAD is a trademark of Texas Instruments.

D (R-PDSO-G14)

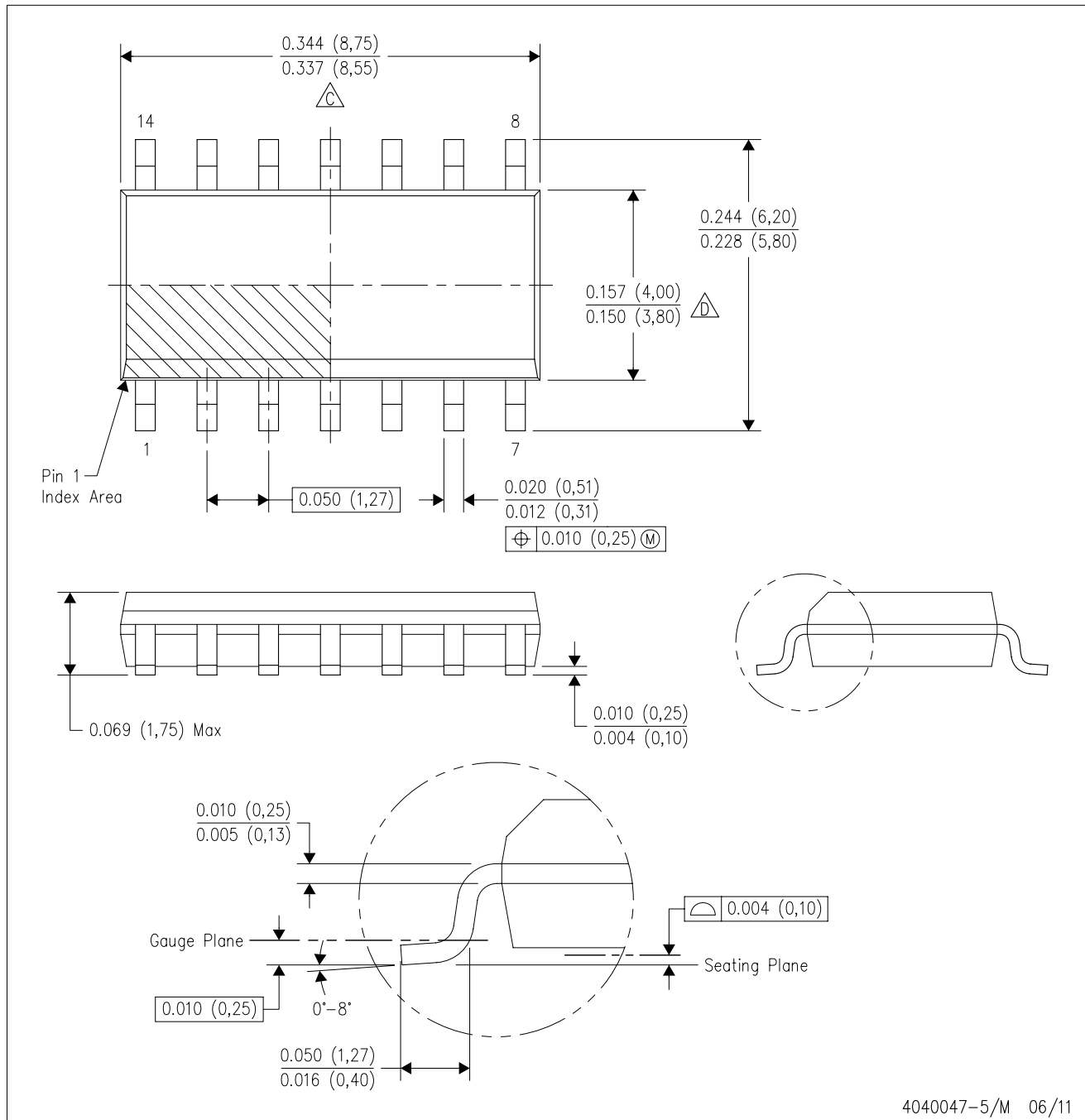
PLASTIC SMALL OUTLINE



- NOTES:
- A. All linear dimensions are in inches (millimeters).
  - B. This drawing is subject to change without notice.
  -  Body length does not include mold flash, protrusions, or gate burrs. Mold flash, protrusions, or gate burrs shall not exceed 0.006 (0,15) each side.
  -  Body width does not include interlead flash. Interlead flash shall not exceed 0.017 (0,43) each side.
  - E. Reference JEDEC MS-012 variation AB.

D (R-PDSO-G14)

PLASTIC SMALL OUTLINE



4211283-3/E 08/12

- NOTES:
- A. All linear dimensions are in millimeters.
  - B. This drawing is subject to change without notice.
  - C. Publication IPC-7351 is recommended for alternate designs.
  - D. Laser cutting apertures with trapezoidal walls and also rounding corners will offer better paste release. Customers should contact their board assembly site for stencil design recommendations. Refer to IPC-7525 for other stencil recommendations.
  - E. Customers should contact their board fabrication site for solder mask tolerances between and around signal pads.



D0008A

# PACKAGE OUTLINE

SOIC - 1.75 mm max height

SMALL OUTLINE INTEGRATED CIRCUIT



4214825/C 02/2019

## NOTES:

- Linear dimensions are in inches [millimeters]. Dimensions in parenthesis are for reference only. Controlling dimensions are in inches. Dimensioning and tolerancing per ASME Y14.5M.
- This drawing is subject to change without notice.
- This dimension does not include mold flash, protrusions, or gate burrs. Mold flash, protrusions, or gate burrs shall not exceed  $.006$  [0.15] per side.
- This dimension does not include interlead flash.
- Reference JEDEC registration MS-012, variation AA.

# EXAMPLE BOARD LAYOUT

D0008A

SOIC - 1.75 mm max height

SMALL OUTLINE INTEGRATED CIRCUIT



LAND PATTERN EXAMPLE  
 EXPOSED METAL SHOWN  
 SCALE:8X



SOLDER MASK DETAILS

4214825/C 02/2019

NOTES: (continued)

- 6. Publication IPC-7351 may have alternate designs.
- 7. Solder mask tolerances between and around signal pads can vary based on board fabrication site.

# EXAMPLE STENCIL DESIGN

D0008A

SOIC - 1.75 mm max height

SMALL OUTLINE INTEGRATED CIRCUIT



SOLDER PASTE EXAMPLE  
BASED ON .005 INCH [0.125 MM] THICK STENCIL  
SCALE:8X

4214825/C 02/2019

NOTES: (continued)

8. Laser cutting apertures with trapezoidal walls and rounded corners may offer better paste release. IPC-7525 may have alternate design recommendations.
9. Board assembly site may have different recommendations for stencil design.

PWP (R-PDSO-G14)

PowerPAD™ PLASTIC SMALL OUTLINE

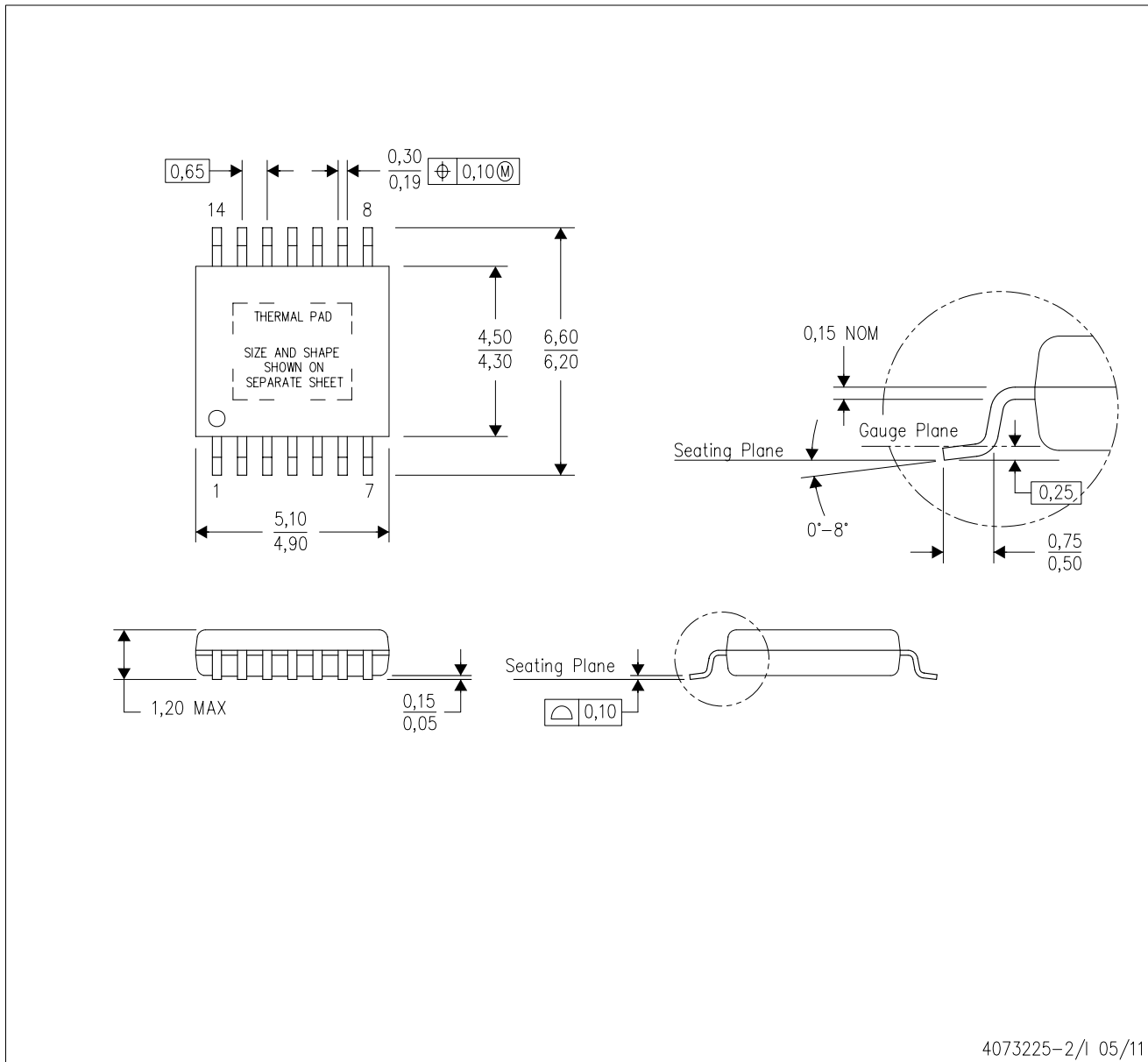

4073225-2/1 05/11

- NOTES:
- All linear dimensions are in millimeters.
  - This drawing is subject to change without notice.
  - Body dimensions do not include mold flash or protrusions. Mold flash and protrusion shall not exceed 0.15 per side.
  - This package is designed to be soldered to a thermal pad on the board. Refer to Technical Brief, PowerPad Thermally Enhanced Package, Texas Instruments Literature No. SLMA002 for information regarding recommended board layout. This document is available at [www.ti.com](http://www.ti.com) <<http://www.ti.com>>.
  - See the additional figure in the Product Data Sheet for details regarding the exposed thermal pad features and dimensions.
  - Falls within JEDEC MO-153

PowerPAD is a trademark of Texas Instruments.

## THERMAL PAD MECHANICAL DATA

PWP (R-PDSO-G14)

PowerPAD™ SMALL PLASTIC OUTLINE

### THERMAL INFORMATION

This PowerPAD™ package incorporates an exposed thermal pad that is designed to be attached to a printed circuit board (PCB). The thermal pad must be soldered directly to the PCB. After soldering, the PCB can be used as a heatsink. In addition, through the use of thermal vias, the thermal pad can be attached directly to the appropriate copper plane shown in the electrical schematic for the device, or alternatively, can be attached to a special heatsink structure designed into the PCB. This design optimizes the heat transfer from the integrated circuit (IC).

For additional information on the PowerPAD package and how to take advantage of its heat dissipating abilities, refer to Technical Brief, PowerPAD Thermally Enhanced Package, Texas Instruments Literature No. SLMA002 and Application Brief, PowerPAD Made Easy, Texas Instruments Literature No. SLMA004. Both documents are available at [www.ti.com](http://www.ti.com).

The exposed thermal pad dimensions for this package are shown in the following illustration.

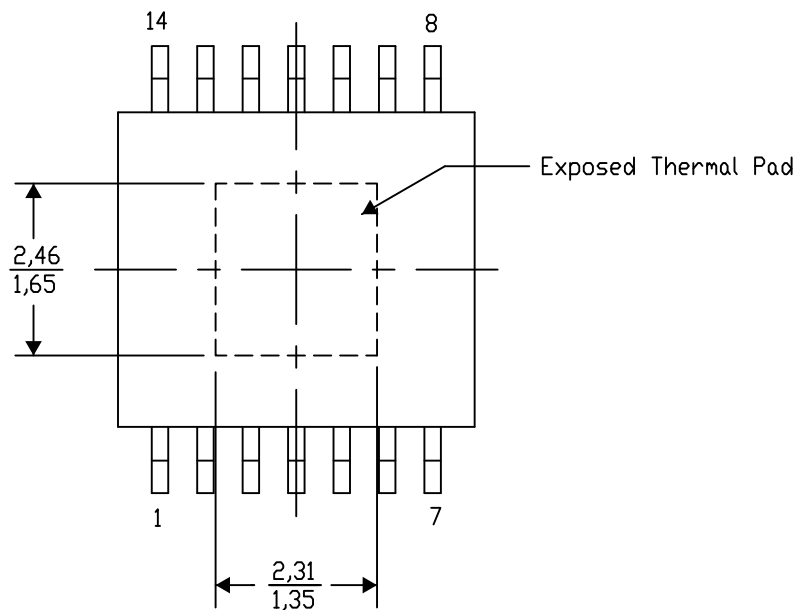

Top View

Exposed Thermal Pad Dimensions

4206332-2/AO 01/16

NOTE: A. All linear dimensions are in millimeters

PowerPAD is a trademark of Texas Instruments

PWP (R-PDSO-G14)

PowerPAD™ PLASTIC SMALL OUTLINE

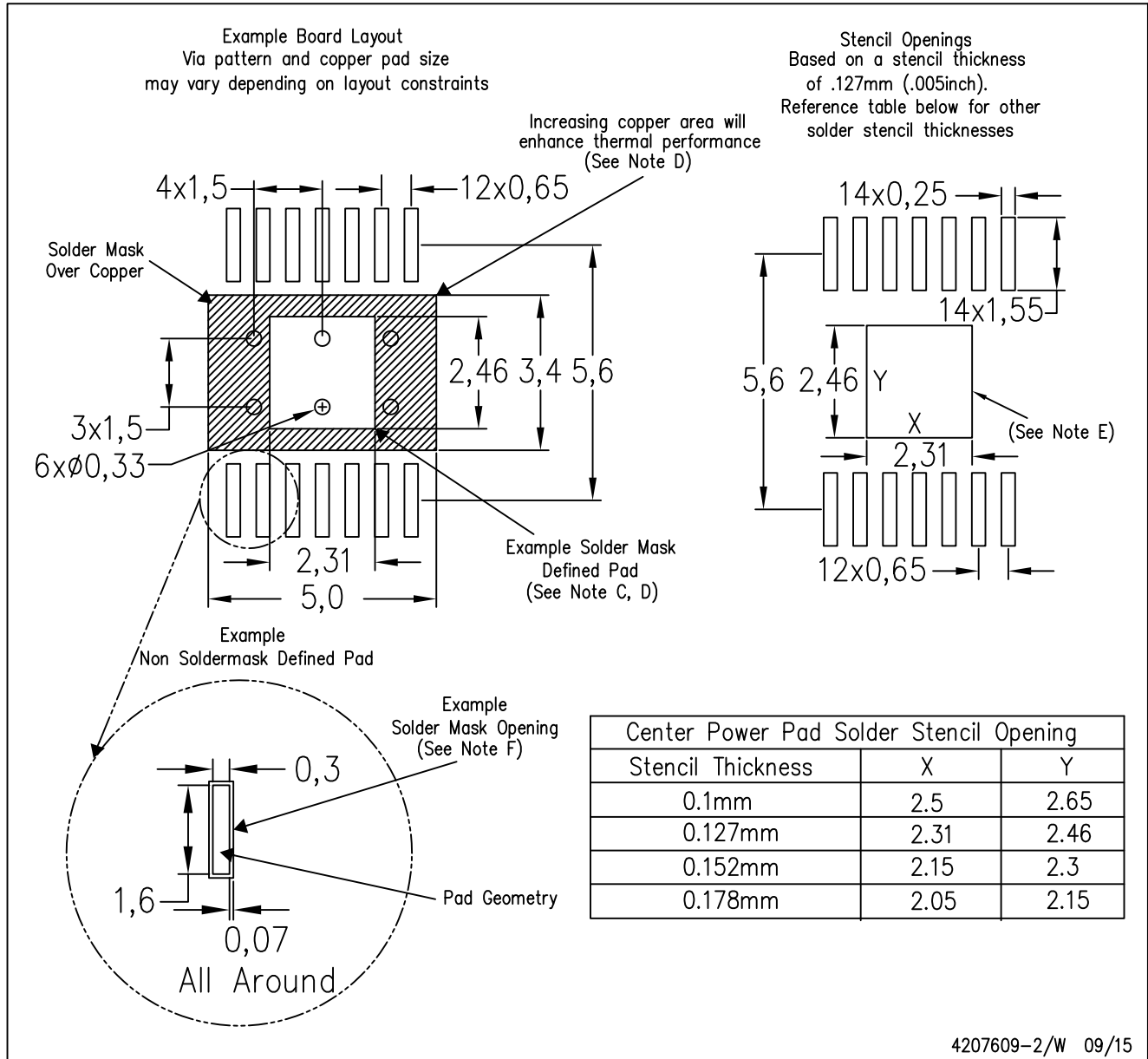

4207609-2/W 09/15

- NOTES:
- A. All linear dimensions are in millimeters.
  - B. This drawing is subject to change without notice.
  - C. Customers should place a note on the circuit board fabrication drawing not to alter the center solder mask defined pad.
  - D. This package is designed to be soldered to a thermal pad on the board. Refer to Technical Brief, PowerPAD Thermally Enhanced Package, Texas Instruments Literature No. SLMA002, SLMA004, and also the Product Data Sheets for specific thermal information, via requirements, and recommended board layout. These documents are available at [www.ti.com](http://www.ti.com) <<http://www.ti.com>>. Publication IPC-7351 is recommended for alternate designs.
  - E. Laser cutting apertures with trapezoidal walls and also rounding corners will offer better paste release. Customers should contact their board assembly site for stencil design recommendations. Example stencil design based on a 50% volumetric metal load solder paste. Refer to IPC-7525 for other stencil recommendations.
  - F. Customers should contact their board fabrication site for solder mask tolerances between and around signal pads.

# THERMAL PAD MECHANICAL DATA

PWP (R-PDSO-G14)

PowerPAD™ SMALL PLASTIC OUTLINE

## THERMAL INFORMATION

This PowerPAD™ package incorporates an exposed thermal pad that is designed to be attached to a printed circuit board (PCB). The thermal pad must be soldered directly to the PCB. After soldering, the PCB can be used as a heatsink. In addition, through the use of thermal vias, the thermal pad can be attached directly to the appropriate copper plane shown in the electrical schematic for the device, or alternatively, can be attached to a special heatsink structure designed into the PCB. This design optimizes the heat transfer from the integrated circuit (IC).

For additional information on the PowerPAD package and how to take advantage of its heat dissipating abilities, refer to Technical Brief, PowerPAD Thermally Enhanced Package, Texas Instruments Literature No. SLMA002 and Application Brief, PowerPAD Made Easy, Texas Instruments Literature No. SLMA004. Both documents are available at [www.ti.com](http://www.ti.com).

The exposed thermal pad dimensions for this package are shown in the following illustration.

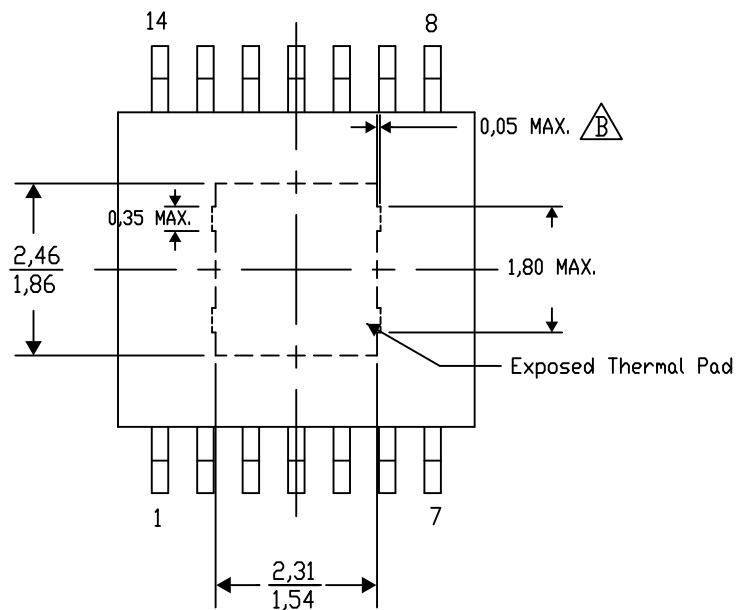

Top View

Exposed Thermal Pad Dimensions

4206332-44/AO 01/16

NOTE: A. All linear dimensions are in millimeters

$\triangle B$  Exposed tie strap features may not be present.

PowerPAD is a trademark of Texas Instruments

PWP (R-PDSO-G14)

PowerPAD™ PLASTIC SMALL OUTLINE

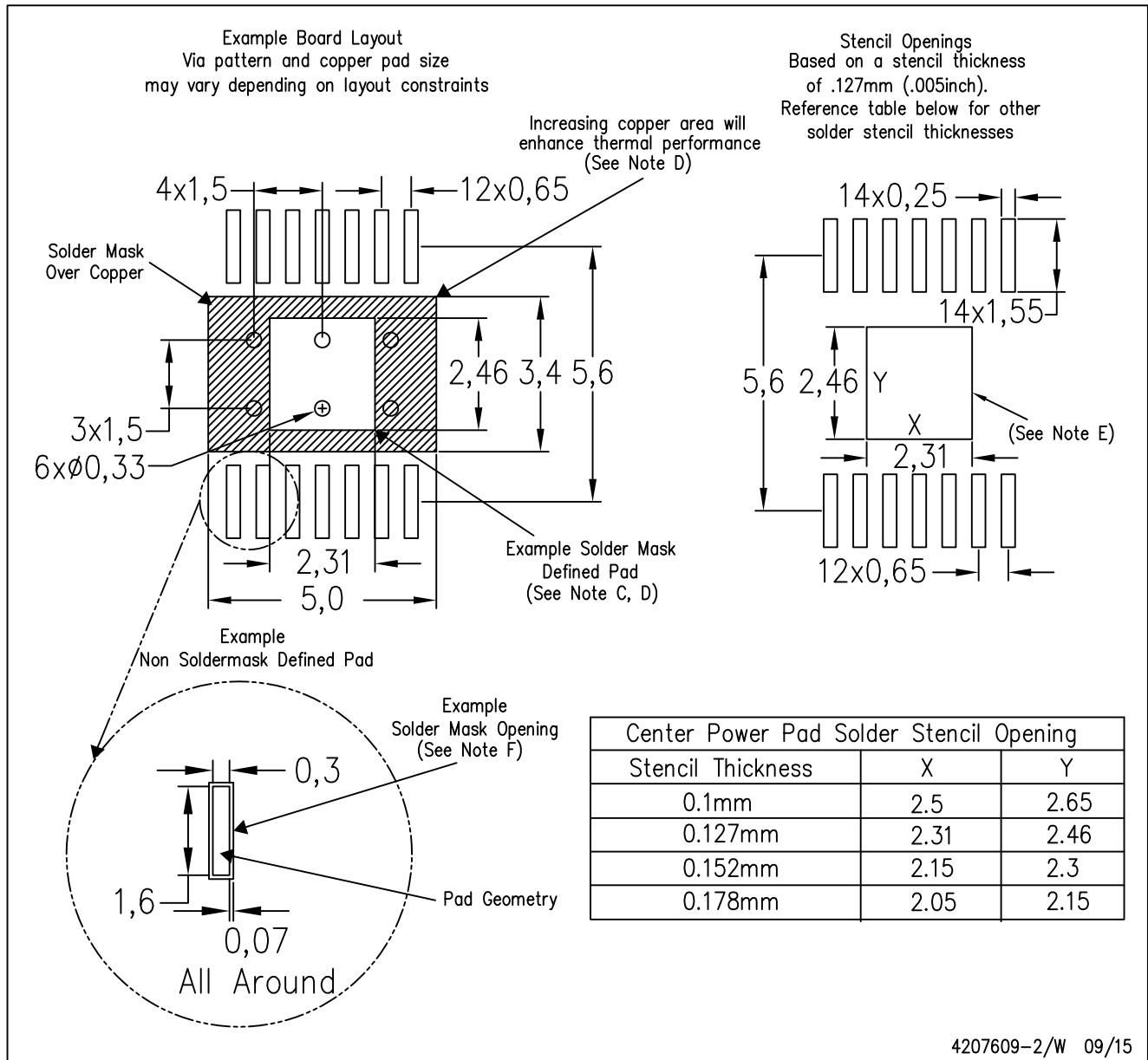

- NOTES:
- A. All linear dimensions are in millimeters.
  - B. This drawing is subject to change without notice.
  - C. Customers should place a note on the circuit board fabrication drawing not to alter the center solder mask defined pad.
  - D. This package is designed to be soldered to a thermal pad on the board. Refer to Technical Brief, PowerPAD Thermally Enhanced Package, Texas Instruments Literature No. SLMA002, SLMA004, and also the Product Data Sheets for specific thermal information, via requirements, and recommended board layout. These documents are available at [www.ti.com](http://www.ti.com) <<http://www.ti.com>>. Publication IPC-7351 is recommended for alternate designs.
  - E. Laser cutting apertures with trapezoidal walls and also rounding corners will offer better paste release. Customers should contact their board assembly site for stencil design recommendations. Example stencil design based on a 50% volumetric metal load solder paste. Refer to IPC-7525 for other stencil recommendations.
  - F. Customers should contact their board fabrication site for solder mask tolerances between and around signal pads.

## IMPORTANT NOTICE AND DISCLAIMER

TI PROVIDES TECHNICAL AND RELIABILITY DATA (INCLUDING DATASHEETS), DESIGN RESOURCES (INCLUDING REFERENCE DESIGNS), APPLICATION OR OTHER DESIGN ADVICE, WEB TOOLS, SAFETY INFORMATION, AND OTHER RESOURCES "AS IS" AND WITH ALL FAULTS, AND DISCLAIMS ALL WARRANTIES, EXPRESS AND IMPLIED, INCLUDING WITHOUT LIMITATION ANY IMPLIED WARRANTIES OF MERCHANTABILITY, FITNESS FOR A PARTICULAR PURPOSE OR NON-INFRINGEMENT OF THIRD PARTY INTELLECTUAL PROPERTY RIGHTS.

These resources are intended for skilled developers designing with TI products. You are solely responsible for (1) selecting the appropriate TI products for your application, (2) designing, validating and testing your application, and (3) ensuring your application meets applicable standards, and any other safety, security, or other requirements. These resources are subject to change without notice. TI grants you permission to use these resources only for development of an application that uses the TI products described in the resource. Other reproduction and display of these resources is prohibited. No license is granted to any other TI intellectual property right or to any third party intellectual property right. TI disclaims responsibility for, and you will fully indemnify TI and its representatives against, any claims, damages, costs, losses, and liabilities arising out of your use of these resources.

TI's products are provided subject to TI's Terms of Sale ([www.ti.com/legal/termsofsale.html](http://www.ti.com/legal/termsofsale.html)) or other applicable terms available either on [ti.com](http://ti.com) or provided in conjunction with such TI products. TI's provision of these resources does not expand or otherwise alter TI's applicable warranties or warranty disclaimers for TI products.

Mailing Address: Texas Instruments, Post Office Box 655303, Dallas, Texas 75265  
Copyright © 2019, Texas Instruments Incorporated

## Looking for pricing, stock, or lifecycle information?

Click below to explore more details on WIN SOURCE:

 [View THS3092DR](#) on WIN SOURCE

 [Texas Instruments](#) Information

## Optimize Your Supply Chain with WIN SOURCE Solutions

-  Global Sourcing Solution
-  Obsolete Management
-  Cost Control Management
-  Shortage Management
-  Alternative Solution
-  Excess Inventory Management